

SERVICE MANUAL

PARTS LIST

MODEL GX-630D PRO



THIS MANUAL MUST BE USED AS A SET TOGETHER WITH
SEPARATELY PUBLISHED GX-630D/DB SERVICE MANUAL

STEREO TAPE DECK

MODEL GX-630D PRO

SECTION 1	SERVICE MANUAL	1
SECTION 2	PARTS LIST	15
SECTION 3	SCHEMATIC DIAGRAM	20

SECTION 1

SERVICE MANUAL

TABLE OF CONTENTS

I. TECHNICAL DATA	2
II. ARRANGEMENT OF PRINCIPAL PARTS	3
III. MECHANISM ADJUSTMENT	4
IV. HEAD ADJUSTMENT	4
V. AMPLIFIER SYSTEM ADJUSTMENT	6
1. DC POWER SUPPLY VOLTAGE ADJUSTMENT	6
2. TAPE SPEED ADJUSTMENT	6
3. RECORDING AND PLAYBACK AMPLIFIER ADJUSTMENT	7
VI. DC RESISTANCE OF VARIOUS COILS	8
VII. CLASSIFICATIONS OF VARIOUS P.C BOARDS	9
1. P.C BOARD INTERCHANGEABILITY CHART	9
2. COMPOSITION OF VARIOUS P.C BOARDS	9

When making adjustment or repairs of Model GX-630D PRO, kindly refer to the following sections of Model GX-630D/DB Service Manual.

Dismantling of unit : page 4

Mechanism Adjustments : page 6 to page 9

I. TECHNICAL DATA

TRACK SYSTEM	2 track 2 channel stereo/monaural system
REEL CAPACITY	Up to 10-1/2" reel
TAPE SPEED	15 and 7-1/2 ips ($\pm 0.5\%$)
WOW & FLUTTER	Less than 0.05% RMS at 15 ips Less than 0.06% RMS at 7-1/2 ips
FREQUENCY RESPONSE	30 to 28,000 Hz ± 3 dB at 15 ips 30 to 25,000 Hz ± 3 dB at 7-1/2 ips
DISTORTION	Less than 0.5% at 15 ips (1,000 Hz '0' VU recording/playback) Less than 0.6% at 7-1/2 ips (1,000 Hz '0' VU recording/playback)
SIGNAL TO NOISE RATIO	Better than 55 dB at 15 ips Better than 57 dB at 7-1/2 ips (Measured via tape with peak recording level of +6 VU)
ERASE RATIO	Better than 70 dB
BIAS FREQUENCY	100 kHz
HEAD	(3): One GX playback head One GX recording head One erase head
MOTOR	(3): One AC servo motor for capstan drive Two eddy current motors for reel drive
FAST FORWARD AND REWIND TIME	120 sec. using a 2,400 ft tape
OUTPUT JACK	Line (2): 0.775V ('0' VU) Required load impedance: More than 20 k ohms Phono (1): 30 mV/8 ohms
INPUT JACK	Microphone (2): 0.25 mV/4.7 k ohms Line (2): 70 mV/150 k ohms
TRANSISTOR	2SA564 (Q)..... 1 2SC945L (Q) (P) 18 2SA564 (R)..... 2 2SC945L (Q) (R) 3 2SC458LG (C)..... 16 2SC1247A (B) (V) 3 2SC711 (G)..... 1 2SD361 (D) (E)..... 1 2SC711 (F) (G)..... 1 2SD361 (D1) (D2) 1 2SC945L (Q) 3
DIODE	1N34A..... 2 10D05 1 1N4001 4 10D2 4 1N4004 5 RD5A (M) 1 1S1588 1 WZ075..... 2 1S2473 21 WZ192..... 1 1S2473VE..... 15 41D26 1
POWER REQUIREMENTS	100 to 240V, 50/60 Hz (switchable)
DIMENSIONS	440(W) x 465(H) x 245(D) mm (17.3" x 18.3" x 9.6")
WEIGHT	19 kg (41.8 lbs)

- NOTES: 1. Specifications were determined with SCOTCH #211 (Low Noise) tape.
2. For improvement purposes, specifications and design are subject to change without notice.

II. ARRANGEMENT OF PRINCIPAL PARTS

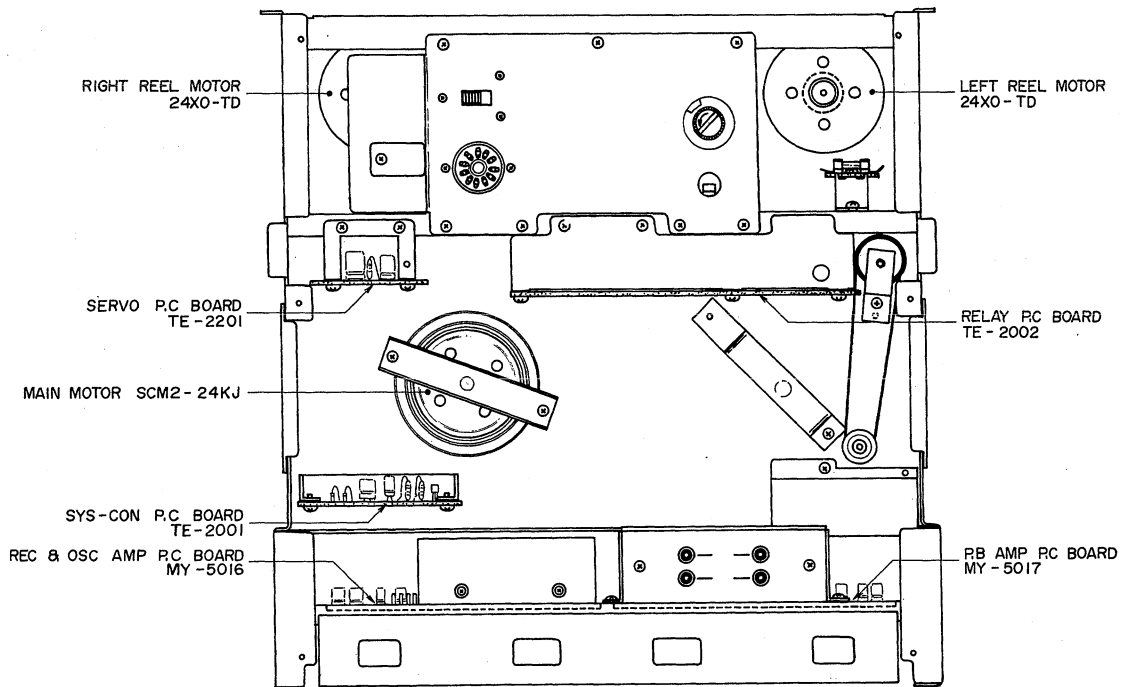
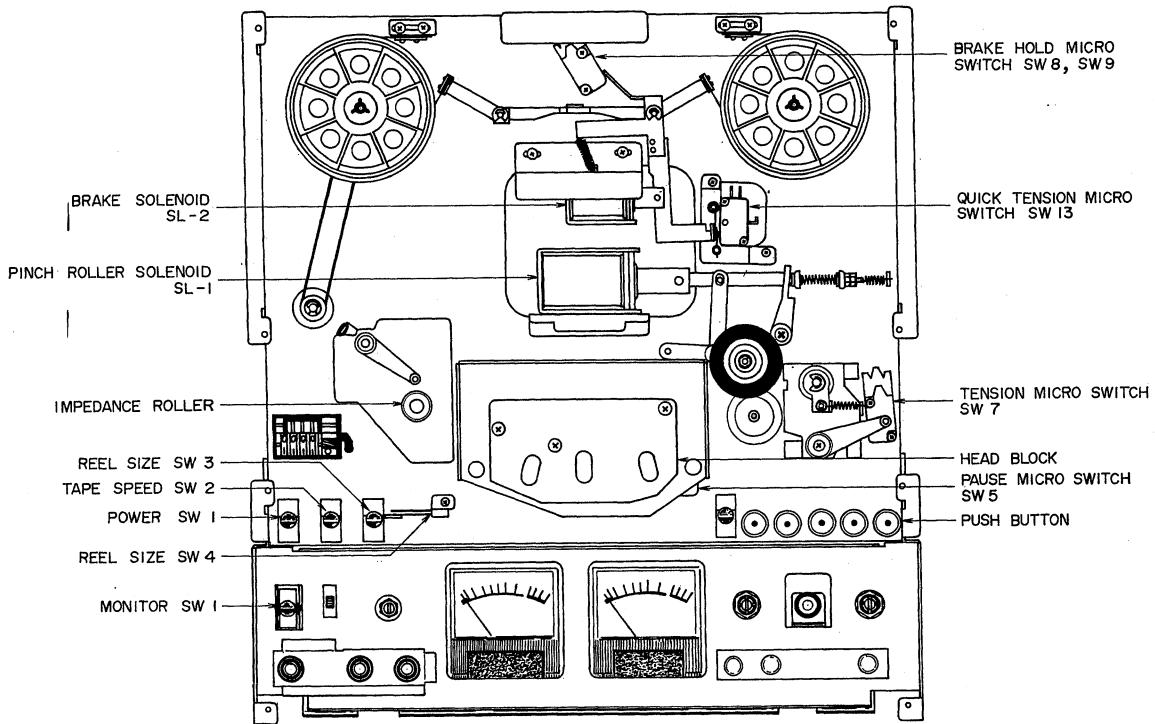

III. MECHANISM ADJUSTMENT

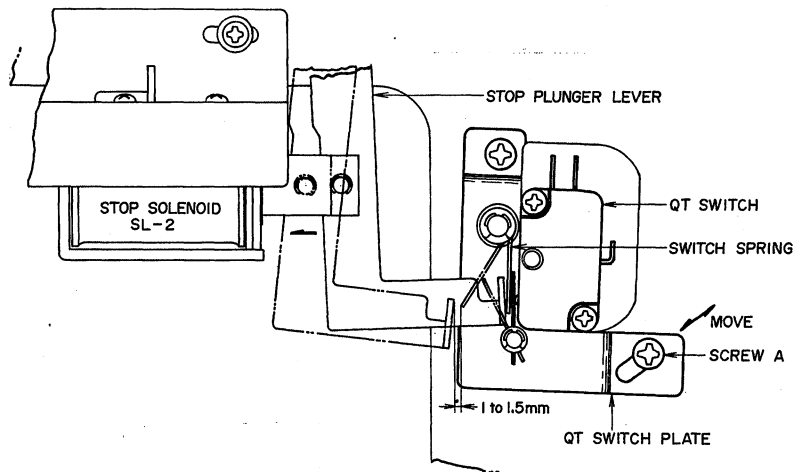

POSITION ADJUSTMENT OF QUICK TENSION MICRO SWITCH

Loosen Screw A and adjust installation position of the QT Switch plate so that the gap between Stop Plunger Lever B and the Switch Spring is 1 to 1.5 mm and the QT Switch is turned off when Stop Plunger Lever B is moved as far as it will go in the direction of the arrow mark in the figure. Tighten Screw A at optimum adjusted position.

IV. HEAD ADJUSTMENT

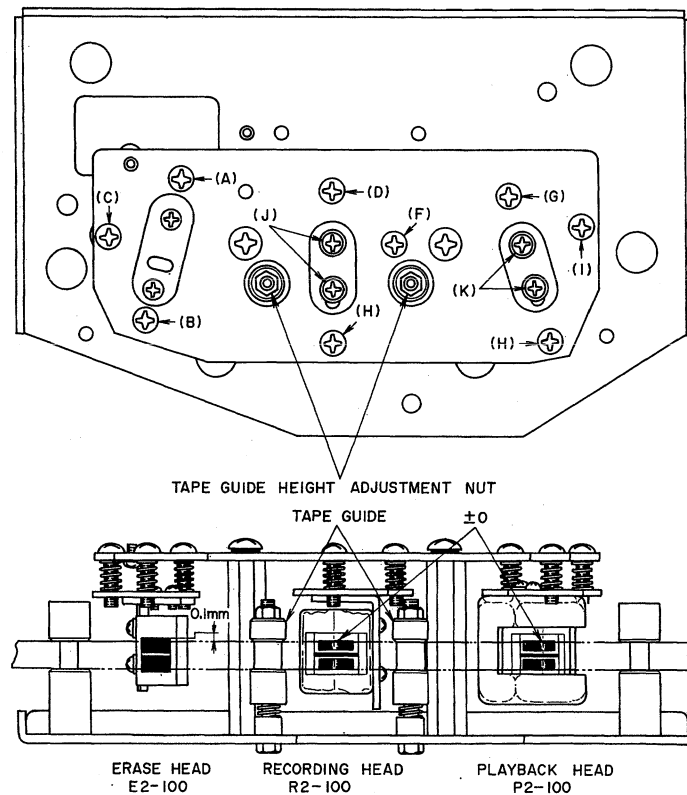

Step	Adjustment Item	Test Tape Supply Signal	MODE	Adjustment Point	Remarks
1	Tape Guide height Adjustment	Optional	PLAY	Tape Guide Height Adjustment Nut	Adjust so that tape does not twist between tape guides on head base.
2	Erase Head Height Adjustment	Optional	PLAY	(A) (B) (C)	Upper edge of left channel head core is 0.1 mm higher than upper edge of tape.
3	Recording Head Height Adjustment	Optional	PLAY	(D) (E) (F)	Upper edges of left channel head core and tape are same height.
4	Playback Head Height Adjustment	Optional	PLAY	(G) (H) (I)	Upper edges of left channel head core and tape are same height.
5	Playback Head Azimuth Alignment Adjustment	8,000 Hz 3-3/4 ips Test Tape	PLAY	(I)	Maximum line output on both channels.
6	Playback Head Gap Alignment Adjustment	8,000 Hz 3-3/4 ips Test Tape	PLAY	(K)	Adjust head gap surface so that there is no change in output level when tension is applied to the supply reel side.
7	Recording Head Azimuth Alignment Adjustment	SCOTCH #211 Tape 15,000 Hz—20 dBm	REC	(F)	Maximum line output on both channels.
8	Recording Head Gap Alignment Adjustment	SCOTCH #211 Tape 15,000 Hz—20 dBm	REC	(J)	Adjust head gap surface so that there is no change in output level when tension is applied to the supply reel side.

Chart 1

- NOTES:
1. As perfect head adjustments are vital to tape deck performance, be sure that these adjustments are carried out properly.
 2. Be careful not to use a magnetized driver or other magnetized tools in the vicinity of the heads.
 3. Use only new tape as level variation is likely to occur when using old tape.
 4. Demagnetize heads with head demagnetizer before and after head adjustment.
 5. Set tape speed to 7-1/2 ips.
 6. Refer to Fig. 2.

V. AMPLIFIER SYSTEM ADJUSTMENT

1. DC POWER SUPPLY VOLTAGE ADJUSTMENT

- a. Set voltmeter or tester to DC 50V range and connect between terminals (6) and (5) of Relay P.C Board.
- b. Adjust Relay P.C Board semi-fixed resistor VR1 1k Ω to obtain 24.0V.

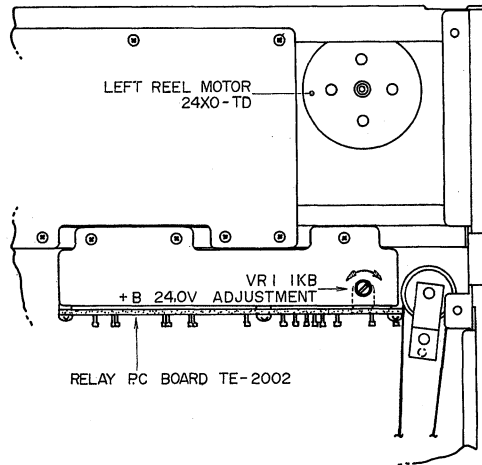

Fig. 3

2. TAPE SPEED ADJUSTMENT

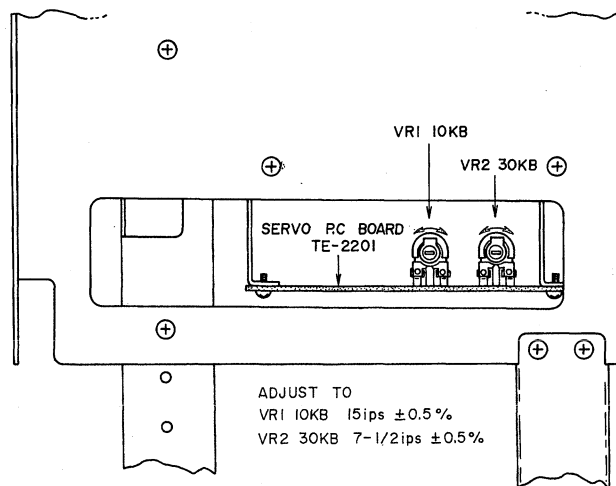

Fig. 4

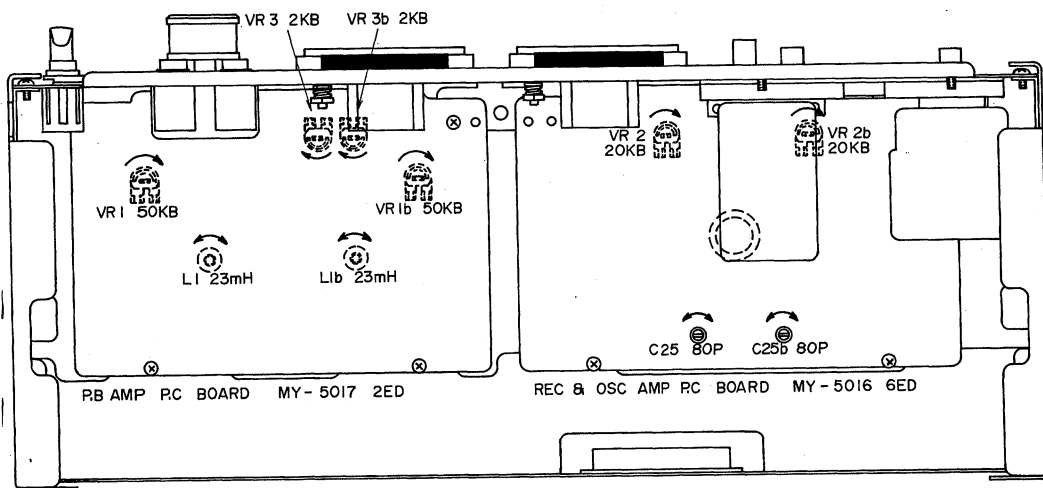

Fig. 5 .

3. RECORDING AND PLAYBACK AMPLIFIER ADJUSTMENT

Step	Adjustment Item	Test Tape Supply Signal	MODE	Adjustment Point	Result	Remarks
1	Playback Level Adjustment	700 Hz 15 ips 0 VU Test Tape	PLAY	VR 1 50 kB	0±0.5 dB (0.775V)	Tape Speed 15 ips.
2	VU Meter Sensitivity Adjustment	700 Hz 15 ips 0 VU Test Tape	PLAY	VR 3 2 kB	0 VU	Tape Speed 15 ips.
3	Recording Level Adjustment	SCOTCH #211 Tape 1,000 Hz 0 VU recording	REC	VR 2 10 kB	0±0.5dB (0.775V)	Tape Speed 7-1/2 ips.
4	Frequency Response Adjustment	SCOTCH #211 Tape 1,000 Hz 10,000 Hz -10 VU recording	REC	C-25 80 P	1,000 Hz to 10,000 Hz flat	Tape Speed 7-1/2 ips. Recheck recording level.
5	Bias Leak		REC	L 1 23 mH	Less than -35 dBm	Monitor Switch to TAPE.

Chart 2

- NOTES: 1. Set Tape Selector to LOW NOISE.
 2. Set output volume to maximum.
 3. New test tape should be used.
 4. The letter "b" following an adjustment parts number indicates "right channel".

VI. DC RESISTANCE OF VARIOUS COILS

Part	Designation	DC Resistance
Main Motor	SCM2-24KJ	Between BLU-RED: 100 ohms Between YLW-GRN: 180 ohms Pick up Coil: 635 ohms
Reel Motor	24XO-TD	Between RED-BLU: 72 ohms Between YLW-GRN: 160 ohms
Pinch Roller Solenoid	1660THT3	700 ohms
Brake Solenoid	1240PHT3	900 ohms
Relay	MY4-02-US-24DC	700 ohms
Relay	LC1-C-J1DC-24V	1,150 ohms
Relay	TECK-36	1,000 ohms
Headphone Output Transformer	N16-535S	Primary: 565 ohms $\pm 15\%$ Secondary: 0.95 ohms $\pm 15\%$
Oscillator Coil	OT-204	Between 1-3: 0.3 ohms Between 4-6: 0.7 ohms Between 7-9: 8.2 ohms
Playback Head	P2-100	250 ohms
Recording Head	R2-100	8 ohms
Erase Head	E2-100	2.5 ohms

Chart 3

NOTE: The resistance values shown in this chart are average values.

VII. CLASSIFICATIONS OF VARIOUS P.C BOARDS

1. P.C BOARD INTERCHANGEABILITY CHART

P.C Board	GX-630DPRO	Interchangeability
Sys. Con P.C Board	TE-2001	Also fits models GX-630D/DB
Relay P.C Board	TE-2002	No
Servo P.C Board	TE-2201	No
PB Amp P.C Board	MY-5017 2ED	No
Rec Mode P.C Board	TE-5003	Also fits models GX-630D/DB
Rec & Osc Amp P.C Board	MY-5016 6ED	No
SRT P.C Board	TD-5006	No
Transistor P.C Board	KJ-2049	Also fits models GX-630D/DB
Speed Switch P.C Board	TE-5201	No

Chart 4

2. COMPOSITION OF VARIOUS P.C BOARDS

1) SYS. CON P.C BOARD TE-2001

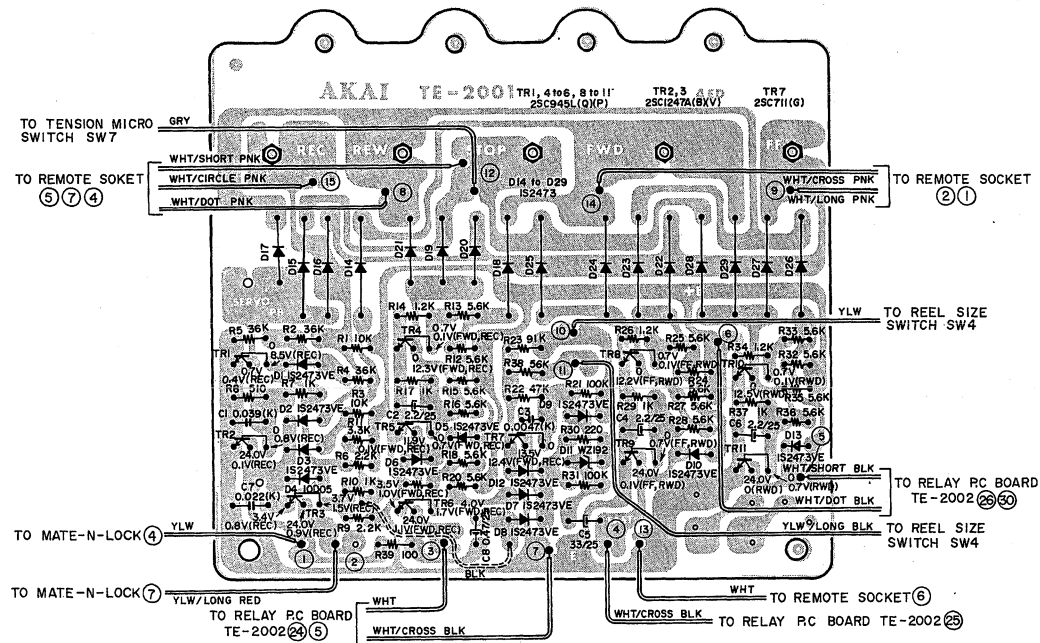

2) RELAY P.C BOARD TE-2002

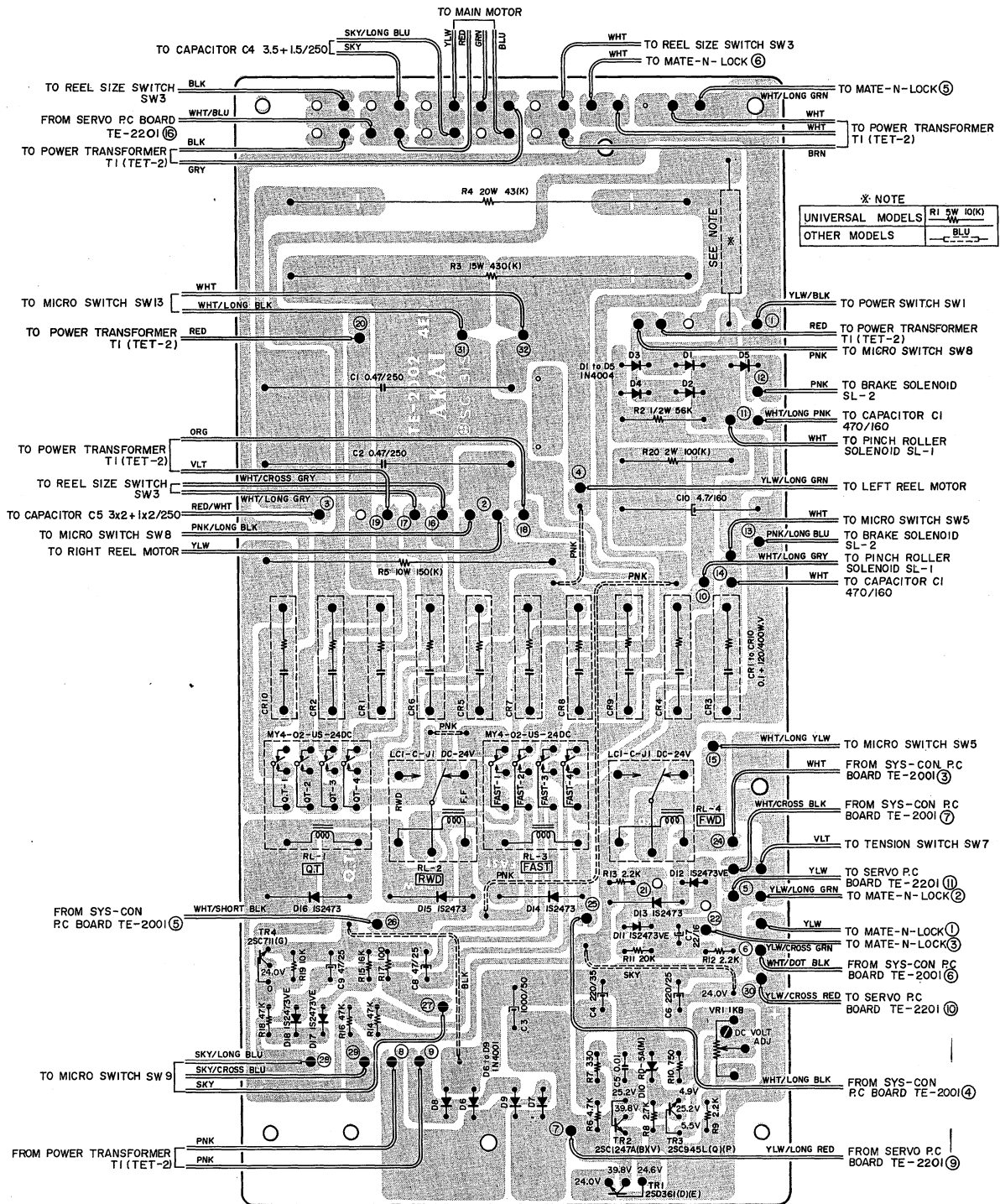

3) SERVO P.C BOARD TE-2201

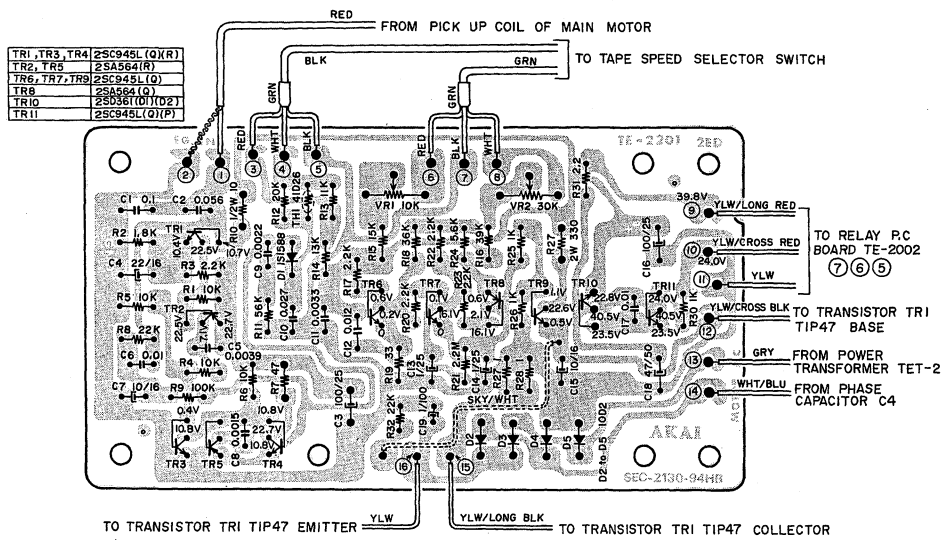

4) PB AMP P.C BOARD MY-5017 2ED

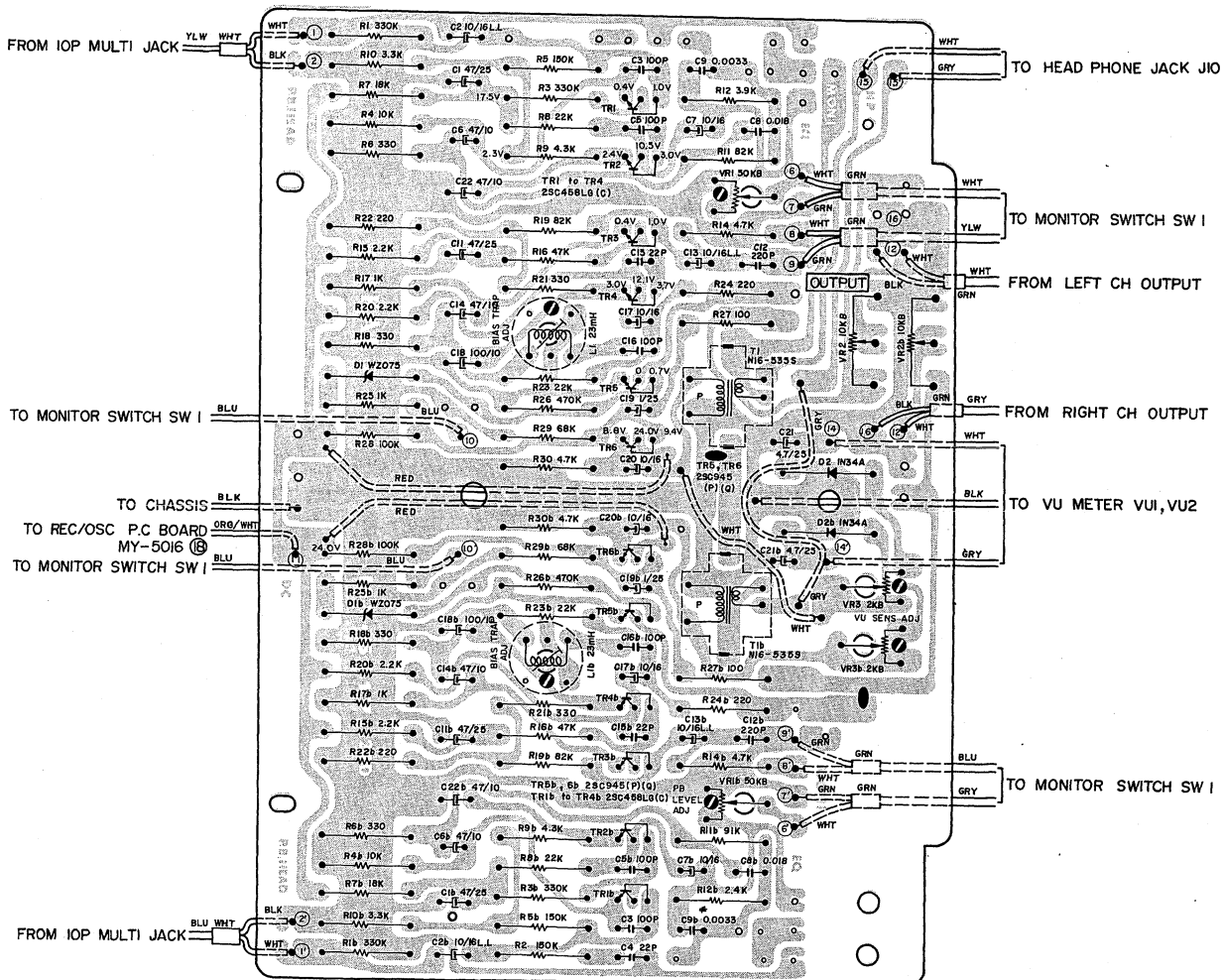

5) REC MODE P.C BOARD TE-5003

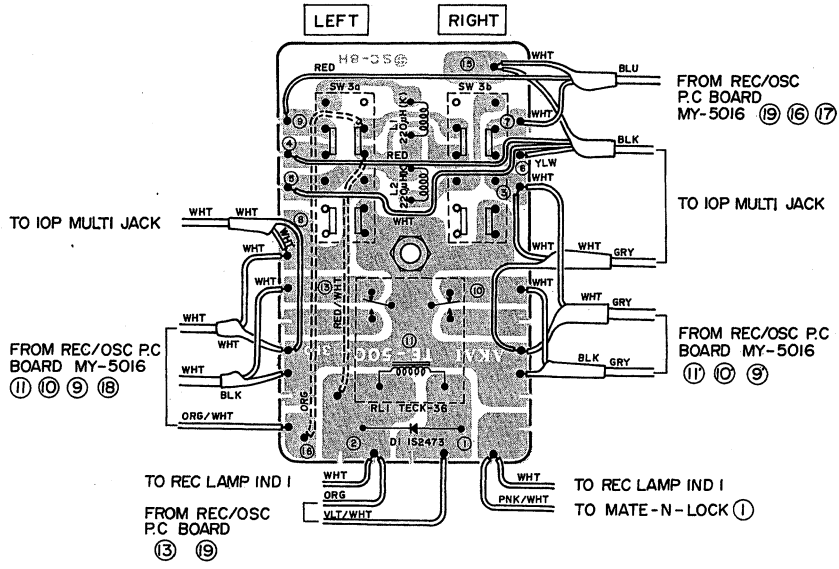

7) SRT P.C BOARD TD-5006

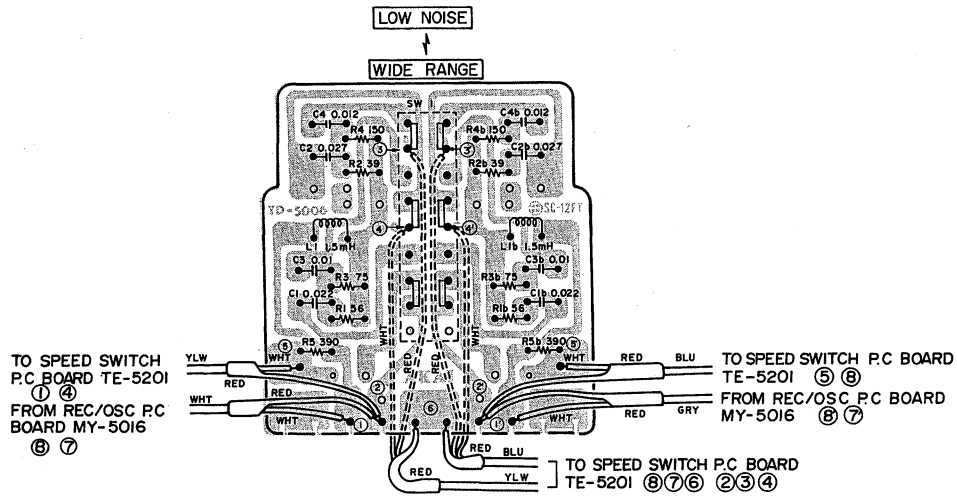

8) TRANSISTOR P.C BOARD KJ-2049

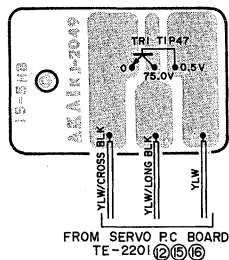

9) SPEED SWITCH P.C BOARD TE-5201

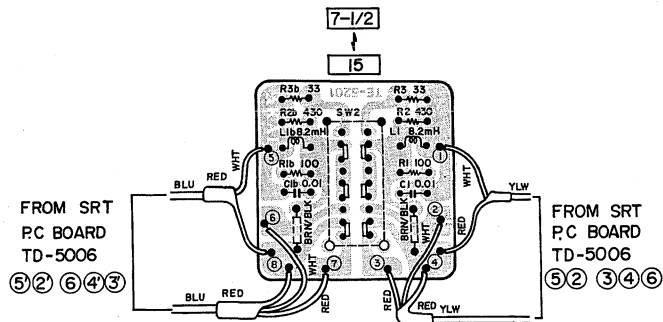

SECTION 2

PARTS LIST

TABLE OF CONTENTS

1	HEAD BLOCK	17
2	MAIN MOTOR BLOCK	17
5	BRAKE PLUNGER BLOCK	17
7	POWER SUPPLY BLOCK	17
8	MECHA. ASSEMBLY BLOCK	17
9	PB AMP P.C BOARD (MY-5017) BLOCK	17
10	REC & OSC AMP P.C BOARD (MY-5016) BLOCK	17
12	SRT P.C BOARD (TD-5006) BLOCK	17
14	SERVO P.C BOARD (TE-2201) BLOCK	17
19	FINAL ASSEMBLY BLOCK	17
	LIST OF INTERCHANGEABLE SEMICONDUCTORS	18
	INDEX	19

The composite parts of Model GX-630DPRO, except for those which have been changes as per the list below, are identical to those of Model GX-630D. Therefore, when ordering parts for this tape deck, please utilize Model GX-630D Parts List.

HOW TO USE THIS PARTS LIST

1. This parts list is compiled by various individual blocks based on assembly process.
2. When ordering parts, please describe parts number, serial number, and model number in detail.
3. How to read List

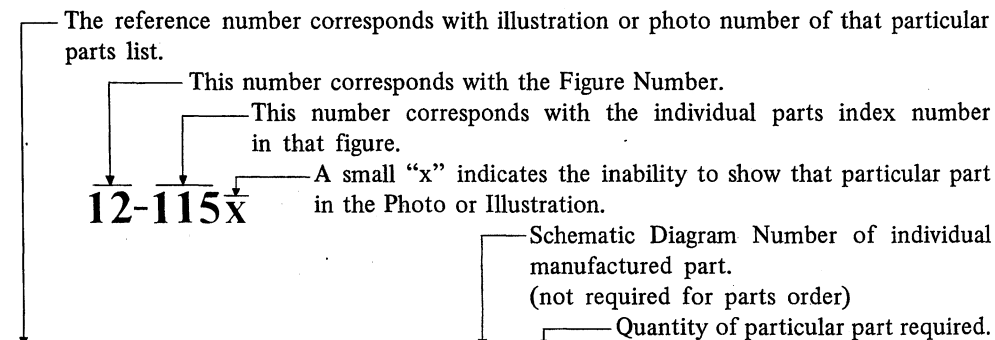

Ref. No.	Parts No.	Description	Schematic No.	Q'ty
FLYWHEEL BLOCK #13				
12-115x	800425	Flywheel Block Assy. Comp.	RDG #13	1
12-116	244506	Flywheel Only	RD-233	1
12-117x	244754	Felt, Flywheel	RD-275	1
12-118	251324	Main Metal Case	RD-236	1
12-119	253080	Main Metal	RD-237	1

4. The symbol numbers shown on the P.C. Board list can be matched with the Composite Views of Components of the Schematic Diagram or Service Manual.
5. Please utilize separate "Common List for Service Parts" for Resistor Parts orders.
6. The shape of the parts and parts name, etc. can be confirmed by comparing them with the parts shown on the Electrical Parts Table of P.C. Board.
7. Both the kind of part and installation position can be determined by the Parts Number. To determine where a parts number is listed, utilize Parts Index at end of Parts List.
It is necessary first of all to find the Parts Number. This can be accomplished by using the Reference Number listed at right of parts number in the Parts Index. (meaning of ref. no. outlined in Item 3 above).
8. Utilize separate "Price List for Parts" to determine unit price. The most simple method of finding parts Price is to utilize the reference number.

1 HEAD BLOCK

Ref. No.	Parts No.	Description	Schematic No.	Q'ty
1-1	BH660701	Head Block Comp.	TE-2	1
1-2	ZG540584	Angle Adjust Spring G (for Erase Head)	TW-0025	3
1-3	HP552205	PB. HEAD P2-100	TW2,4,TD-2	1
1-4	HR552216	REC. HEAD R2-100	TW2,4,TD-2	1
1-5	HE587790	ERASE HEAD E2-100	TD-2	1

2 MAIN MOTOR BLOCK

Ref. No.	Parts No.	Description	Schematic No.	Q'ty
2-1	BM694596	Main Motor Block Comp. (SCM-2-24KJ)	TE-2	1
2-2	BZ694607	Detector Gear Block Comp. (SCM3-16TW)	TE-2	1

5 BRAKE PLUNGER BLOCK

Ref. No.	Parts No.	Description	Schematic No.	Q'ty
5-1	BZ671411	Brake Plunger Block Comp.	TE-2	1
5-2	ML674785	Brake Lever Plunger Lever B	TE-2206	1

7 POWER SUPPLY BLOCK

Ref. No.	Parts No.	Description	Schematic No.	Q'ty
7-1	BT654445	Power Trans. TET-2	38-4-386	1
7-2	BT661915	Power Trans. TET-6	38-4-390	1
7-3	EC694361	MP/C. (Lug Type UNI/D.) 3.5+1.5μF 250WV AC	24-9-115	1
7-4	EF666000	Fuse 0.2A 125V (JPN)	39-1-52	1
7-5	EF588420	Fuse 1A 125V (JPN)	29-1-52	5
7-6	ED650968	Thermister (SINE) PTH62AR 100M (JPN)	45-14-3	2

8 MECHA. ASSEMBLY BLOCK

Ref. No.	Parts No.	Description	Schematic No.	Q'ty
QT SW. TABLE BLOCK				
8-1	BS671398	QT SW. Table Block Comp.	TE-2	1
8-2	EZ674796	QT SW. Table (W/shaft)	TE-2207	1
8-3	MH527635	SW. Pipe	ND-1054	1
8-4	MZ529391	Quick Plate	ND-1063	1
8-5	ZG529211	SW. Spring	ND-1053	1
8-6	ZW273756	Nut M3		1
8-7	ZW259738	Washer (Polyslider) D4.1x7x0.25t		1
8-8	ZW270101	'E' Ring 3M	6-1-9	1
8-9	ZW270088	'E' Ring 1.9M	6-1-9	1
8-10	ES438535	Micro SW. V-1A442 U/L	25-1-15	1
8-11	MZ250413	Micro Insulator C	RC-127	1
PINCH ROLLER PLUNGER BLOCK				
8-12	ED224550	Silicon Diode 10D4	45-2-16	1
8-13	MS672322	Pinch Roller Shaft	TE-2204	1
8-14	MZ672333	P Shaft Collar	TE-2205	1
ASSEMBLY BLOCK				
8-15	MZ636985	Shifter Plate	TD-1028	1
8-16	MZ688140	Spring Plate	TE-1204	1

Ref. No.	Parts No.	Description	Schematic No.	Q'ty
8-17	BI671400	Impedance Roller Block		
		Comp.	TE-2	1
8-18	MP653591	Pinch Roller	TE-1202	1
8-19	ZW560215	Washer D6.1x10x0.5t (Teflon)		2
8-20	ZW260010	Washer D6.1x10x0.1t (PBP)		1
8-21	ES250064	Micro Switch V-1A44 U/L	25-1-7	1

9 PB AMP P.C BOARD (MY-5017) BLOCK

Symbol No.	Parts No.	Description	Q'ty
9-1	BA660824	PB Amp P.C Board Comp. (MY-5017 2ED)	1

10 REC & OSC AMP P.C BOARD (MY-5016) BLOCK

Symbol No.	Parts No.	Description	Q'ty
10-1	BA660813	Rec & Osc Amp P.C Board Comp. (MY-5016 6ED)	1

12 SRT P.C BOARD (TD-5006) BLOCK

Symbol No.	Parts No.	Description	Q'ty
12-1	BA660756	SRT P.C Board Comp. (TD-5006)	1
12-SW1	ES550001	Push SW. 1FS-6U-49	1

14 SERVO P.C BOARD (TE-2201) BLOCK

Symbol No.	Parts No.	Description	Q'ty
14-1	BA660870	Servo P.C Board Comp. (TE-2201)	1
14-TR1	ET398711	Transistor 2SC945L (Q) (R)	1
14-TR2	ET356984	Transistor 2SA564 (R)	1
14-TR3,4	ET398711	Transistor 2SC945L (Q) (R)	2
14-TR5	ET356984	Transistor 2SA564 (R)	1
14-TR6,7	ET399846	Transistor 2SC945L (Q)	2
14-TR8	ET350335	Transistor 2SA564 (Q)	1
14-TR9	ET399846	Transistor 2SC945L (Q)	1
14-TR11	ET639437	Transistor 2SC945L (Q) (P)	1
14-D1	ED557447	Silicon Diode 1S1588	1
14-D2to5	ED224548	Silicon Diode 10D2	4

19 FINAL ASSEMBLY BLOCK

Ref. No.	Parts No.	Description	Schematic No.	Q'ty
MECHA. PANEL BLOCK				
19-1	BZ660453	Mecha. Panel Block Comp.	TE-2	1
19-2	SE640776	Motor Escutcheon B	TE-6002	1
AMP PANEL BLOCK				
19-4	SP654502	Amp Panel (PRO)	TE-6008	1
ASSEMBLY BLOCK				
19-5	SK632610	Pinch Roller Cap B	TW-6019	1

LIST OF INTERCHANGEABLE SEMICONDUCTORS

As far as service is concerned, in case the original parts cannot be obtained, the interchangeable parts listed below can be substituted.

Original Parts			Interchangeable Parts	
Description	Parts No.	Utilizing P.C Board	Description	Parts No.
2SA564 (Q) 2SA564 (R)	ET350335 ET356984	TE-2201	2SA640 (E) (F) 2SA628 (D) (E) 2SA733 (Q) (R)	ET623790 ET538110 ET538378
2SC458LG (C)	ET234854	MY-5016 MY-5017	2SC693U (F) 2SC1312R (G) (H) 2SC1312S (G) (H)	ET315472 ET610413 ET603257
2SC711 (G)	ET399870	TE-2001	2SC945L (K) (P) 2SC1647 (E)	ET635220 ET649945
2SC711 (F) (G)	ET398777	TE-2002	2SC536 (E) (F) 2SC945 (E) (F)	ET370607 ET398711
2SC945L (Q) 2SC945L (Q) (P) 2SC945L (Q) (R)	ET399846 ET639437 ET635837	TE-2201 TE-2001 ET-2002 MY-5016 MY-5017	2SC711 (E) (F) 2SC1641 (R) (S) (E) 2SC1647 (R) (S) (E)	ET453486 ET603843 ET623733
2SC1247A (B) (V)	ET511920	TE-2001 TE-2002	2SC1211 (E) (E)	ET511694
2SD361 (D) (E) 2SD361 (D1) (D2)	ET537000 ET623867	TE-2002	2SC1061 (B) (C) 2SC1449 (K) (L) (H)	ET375603 ET635815
TIP 47	ET621775	KJ-2049	TIP 48	ET621786
1N34A	ED219464	MY-5017	1N60	ED428264
1N4001	ED511097	TE-2002	10D05	ED494583
1N4004	ED570273	TE-2002	10D4	ED224550
1S1588	ED557447	TE-2201	1S2473 WG599 1S2473VE	ED624903 ED514721 ED560913
1S2473	ED624903	TE-2001 TE-2002 TE-5003	1S1588	ED557447
1S2473VE	ED560913	TE-2001 TE-2002	WG 599 WG 713	ED514721 ED515790
10D05	ED494583	TE-2001	1N4001	ED511097
RD-5A (M)	ED357794	TE-2002		
WZ 075	ED570475	MY-5017		
WZ 192	ED498150	TE-2001		

INDEX

Parts No.	Ref. No. & Symbol No.	Parts No.	Ref. No. & Symbol No.	Parts No.	Ref. No. & Symbol No.	Parts No.	Ref. No. & Symbol No.
BA660756	12-1						
BA660813	10-1						
BA660824	9-1						
BA660870	14-1						
BH660701	1-1						
BI671400	8-17						
BM694596	2-1						
BS671398	8-1						
BT654445	7-1						
BT661915	7-2						
BZ660453	19-1						
BZ671411	5-1						
BZ694607	2-2						
EC694361	7-3						
ED224548	14-D2to5						
ED224550	8-12						
ED557447	14-D1						
ED650968	7-6						
EF588420	7-5						
EF666000	7-4						
ES250064	8-21						
ES438535	8-10						
ES550001	12-SW1						
ET350335	14-TR8						
ET356984	14-TR2						
ET356984	14-TR5						
ET398711	14-TR1						
ET398711	14-TR3,4						
ET399846	14-TR6,7						
ET399846	14-TR9						
ET639437	14-TR11						
EZ674796	8-2						
HE587790	1-5						
HP552205	1-3						
HR552216	1-4						
MH527635	8-3						
ML674785	5-2						
MP653591	8-18						
MS672322	8-13						
MZ250413	8-11						
MZ529391	8-4						
MZ636985	8-15						
MZ672333	8-14						
MZ688140	8-16						
SE640776	19-2						
SK632610	19-5						
SP654502	19-4						
ZG529211	8-5						
ZG540584	1-2						
ZW259738	8-7						
ZW260010	8-20						
ZW270088	8-9						
ZW270101	8-8						
ZW273756	8-6						
ZW560215	8-19						

SECTION 3

SCHEMATIC DIAGRAM

- 1. GX-630D-PRO No. 3-1 1520852A SCHEMATIC DIAGRAM**
- 2. GX-630D-PRO No. 3-2 1520853A SCHEMATIC DIAGRAM**
- 3. GX-630D-PRO No. 3-3 1520854A SCHEMATIC DIAGRAM**

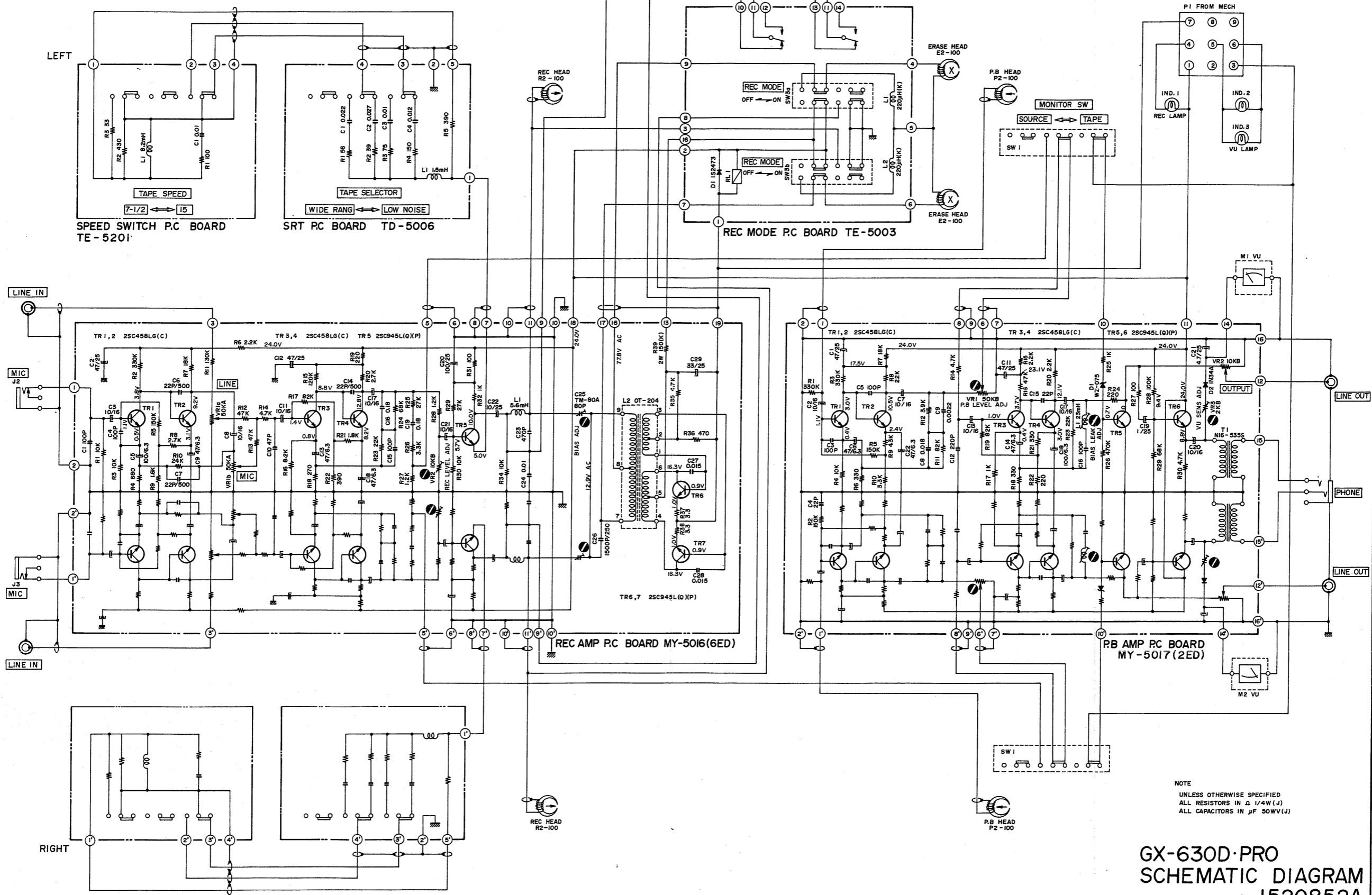

NOTE
UNLESS OTHERWISE SPECIFIED
ALL RESISTORS IN Δ 1/4W (J)
ALL CAPACITORS IN μ F 50WV (J)

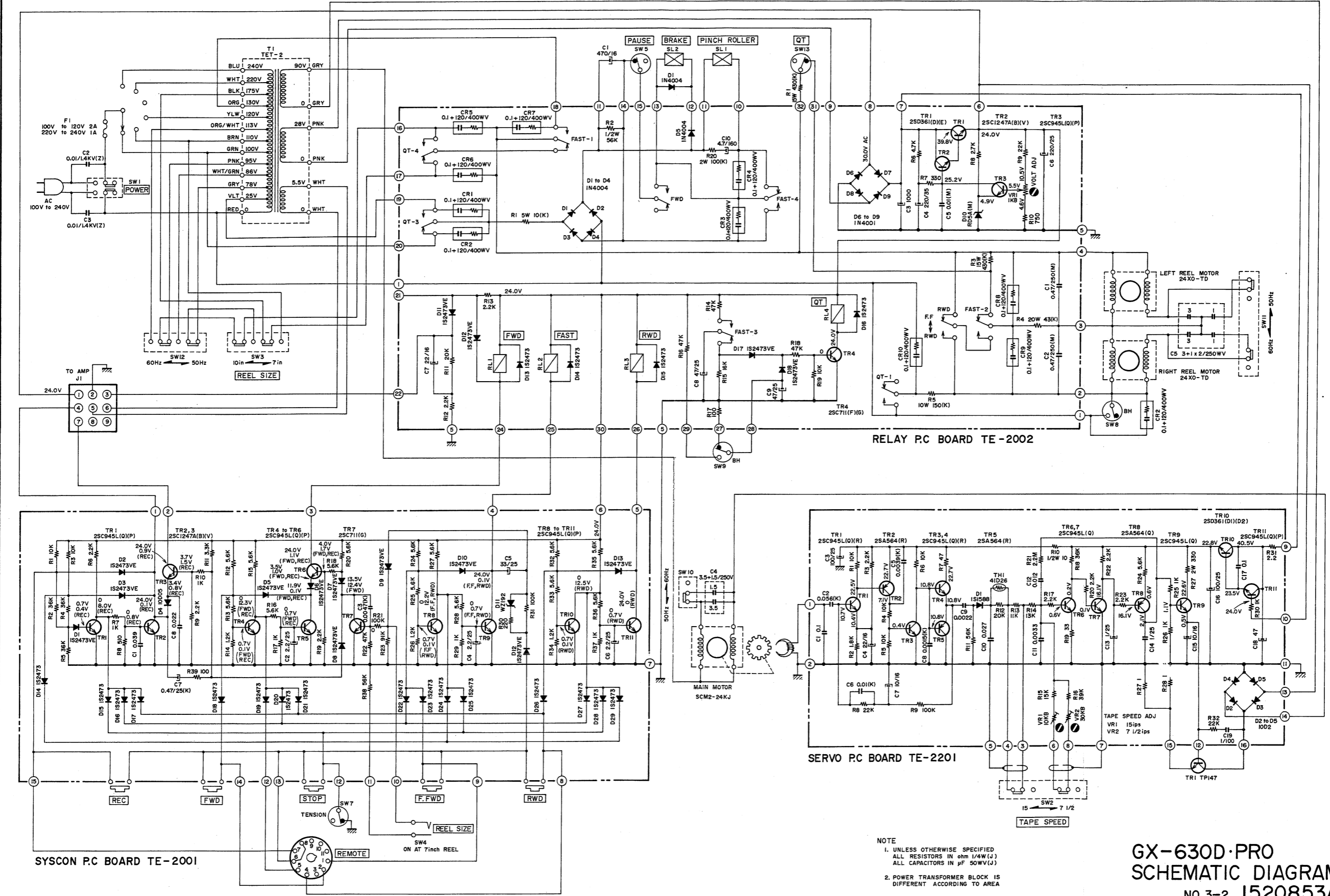

NOTE
 1. UNLESS OTHERWISE SPECIFIED
 ALL RESISTORS IN OHM 1/4W(1)
 ALL CAPACITORS IN μF 50WV(J)
 2. POWER TRANSFORMER BLOCK IS
 DIFFERENT ACCORDING TO AREA

GX-630D·PRO
 SCHEMATIC DIAGRAM
 No. 3-2 1520853A

GX-630D·PRO

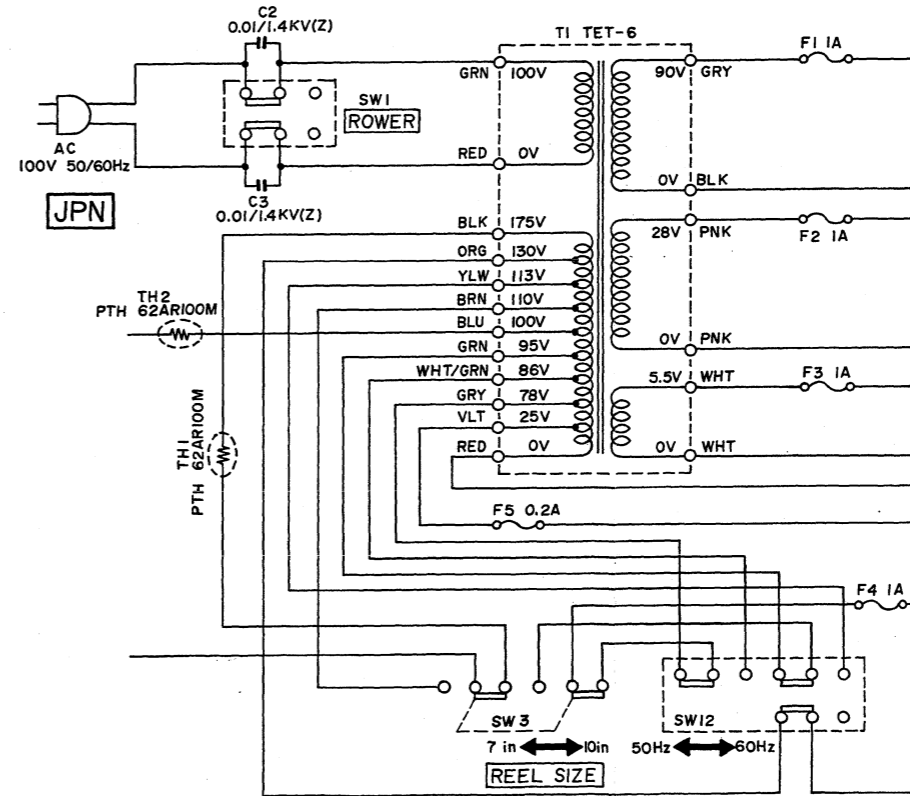
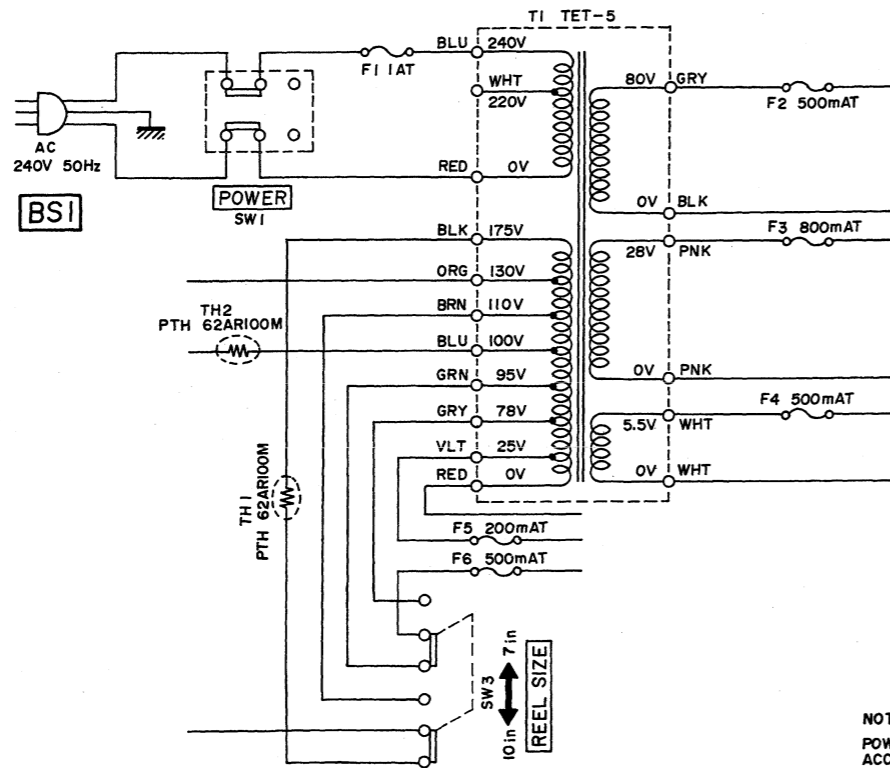
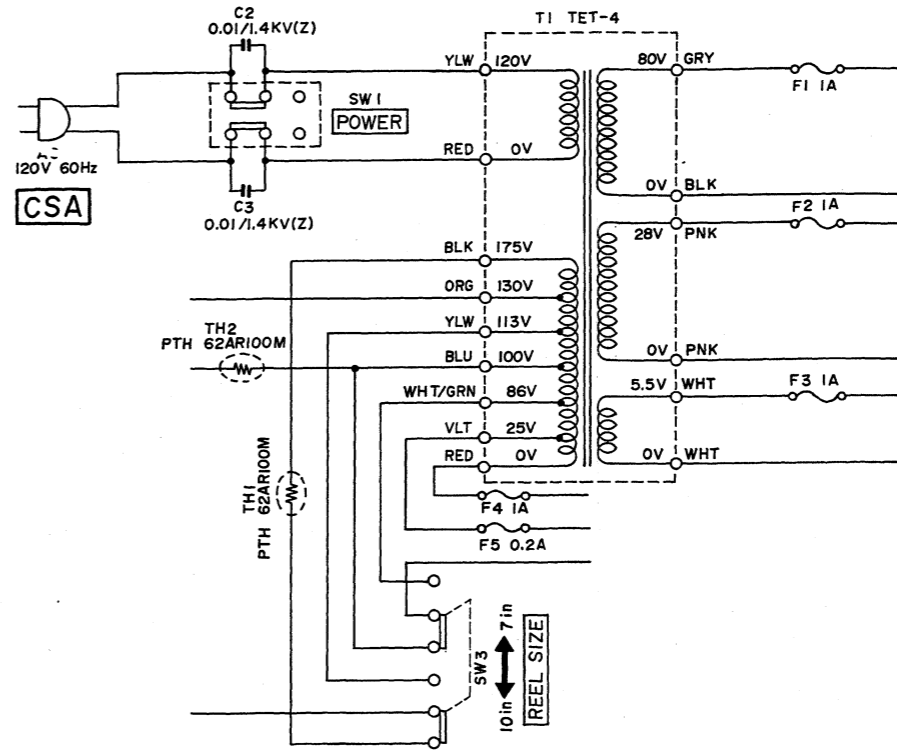
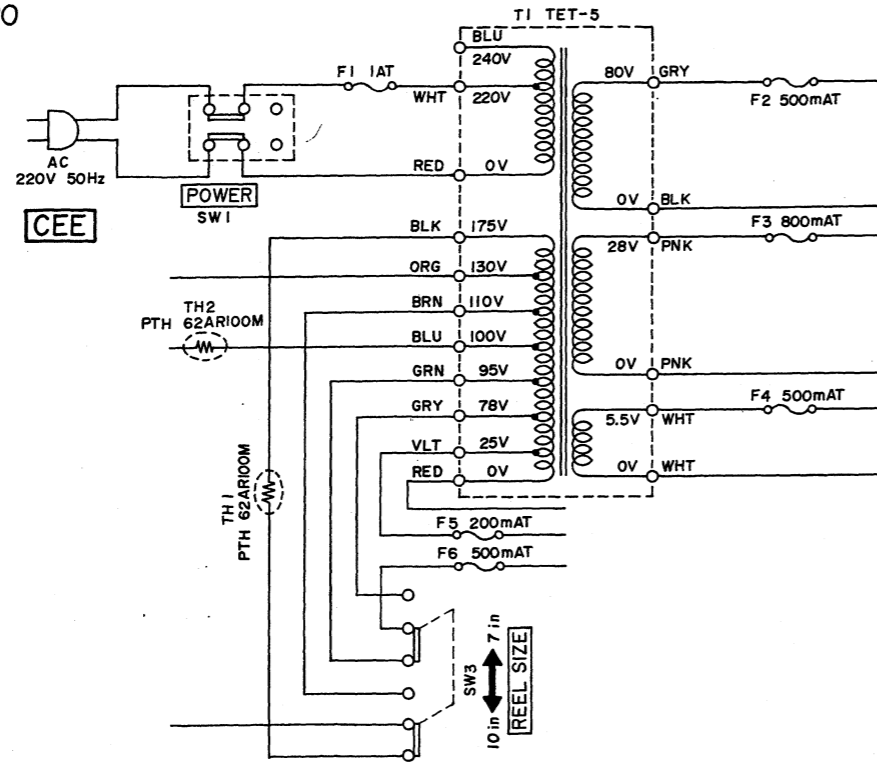

NOTE
POWER TRANSFORMER BLOCK IS DIFFERENT
ACCORDING TO AREA

GX-630D·PRO SCHEMATIC DIAGRAM
NO. 3-3 1520854A