



RECEIVED

72 NOV 14 AM 10:25

LIBRARY OF CONGRESS
COPYRIGHT SECTION

FY 1973
COMMERCIAL
CATALOG



FIDELITY SOUND COMPANY

1200 18th St., N.W.

296-9110
(Area Code 202)

WASHINGTON, D. C.
(Zip Code 20036)

SONY/SUPERSCOPE

TC-55

**Sub-Miniature Battery-Operated Cassette-Corder[®]
with Built-In Condenser Microphone and Automatic Shut-Off**



Slightly larger than two packs of cigarettes, the all-new SONY TC-55 Sub-Miniature Battery-Operated Cassette-Corder tucks away to provide the ultimate in carrying convenience. But don't let the small size fool you. Underneath its rugged all-metal skin, this mighty midget offers performance that surpasses many larger recorders. The pinpoint accuracy of the TC-55's locking Pause Control, plus a high-torque Servo-Control motor, lets you literally stop and start in the middle of a word. And Dual Differential-Balanced Flywheels assure constant tape speed for perfect recording and playback in any carrying position. As further evidence of the almost incredible sophistication in this small package, you'll find a special Sonymatic Music/Speech Selector Switch for optimum recording of speech or music. The extreme sensi-

tivity of SONY's famous Built-In Condenser Microphone actually picks up whispers from across the room. And Automatic Shut-Off means longer battery life and less wear. Although designed primarily for battery operation, the dependable SONY TC-55 will never let you down with power problems. Because an optional new AC Power Supply with quick-charging Nickel-Cadmium Battery Pack runs your TC-55 off regular AC current and recharges the batteries at the same time! There's also the added convenience of a Three-Digit Tape Counter, Fast-Cueing, Locking Fast-Forward and Rewind, as well as Sonymatic Recording Control.

No question about it: the innovative SONY TC-55 is truly the mighty midget of the world of tape recording.

 **FIDELITY SOUND COMPANY**

Sony/Superscope TC-55

Sub-Miniature Battery-Operated Cassette-Corder®

with Built-In Condenser Microphone and Automatic Shut-Off

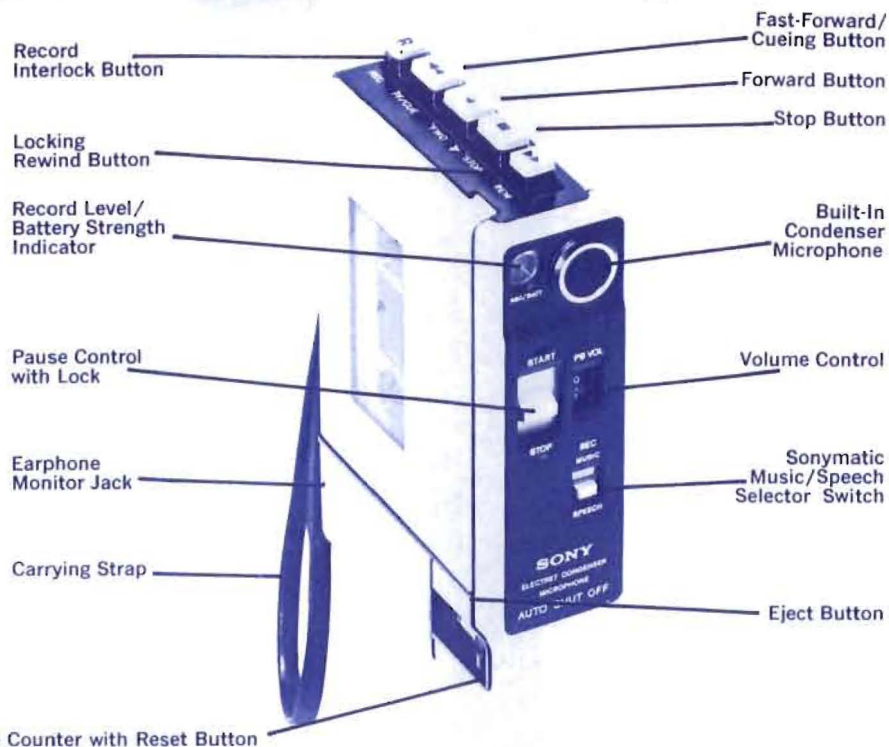

In addition to the features shown, the TC-55 also includes Servo-Control Motor, Non-Magnetizing Record Head, Sonymatic Recording Control, Automatic Shut-Off, and Dual Differential-Balanced Flywheels, Microphone and Auxiliary Input Jacks, Earphone Monitor Jack, and Power Input Jack.

SUPPLIED ACCESSORIES:

ME-21 Personal Earphone
RK-64 Patch Cord
Size AA Batteries (4)
Carrying Case
C-30 Cassette

RECOMMENDED

SONY TAPE AND ACCESSORIES:

C-30, C-60, C-90, C-120 Low Noise Auto-Sensor Cassettes
UHF C-60, UHF C-90, UHF C-120 Ultra-High Fidelity Auto-Sensor Cassettes
ECM-16 Tie-Clasp/Lapel Condenser Microphone
ECM-18 Economy Condenser Microphone
ECM-19B Cardioid Condenser Microphone
ECM-95S Cardioid Condenser Stop/Start Microphone
F-25S Dynamic Stop/Start Microphone
AK-3 AC Power Supply/Rechargeable Nickel-Cadmium Battery Pack

DCC-126 Auto/Boat Cigarette

Lighter Adapter
FS-6 Foot Switch
BE-7 Cassette Insta-Erase
MX-6S Stereo Mixer
RM-15 Remote Control
TP-5S Telephone Pick-Up

SPECIFICATIONS:

Power Requirements:
DC: 6 Volts
Battery size and quantity:
Size "AA" (4)
Battery life: 2 hours continuous
Tape Speed: 1 7/8 ips
Reel Size: Cassette
Recording System: Half-Track Mono
Rewind and Fast-Forward Time:
120 sec (rewind)
100 sec (fast forward) per C-60
Frequency Response (Standard Tape): 90 Hz to 10kHz @ 1 7/8 ips
Bias Frequency: 41 kHz
Type of Level Indication: Record Level/Battery Strength Indicator

Power Output:

350m Watts IHF Dynamic Power

Head Configuration:

1 Half-Track Erase
1 Half-Track Record/Playback

Wow & Flutter: 0.35% @ 1 7/8 ips

Number and Type of Motor:
1 Servo-Controlled DC

Inputs:

1 Microphone:
Plug type: Mini
Impedance: Low
Input sensitivity: -72 dB
(can be used as a magnetic phono input with optional RK-66 adapter.)

Outputs:

1 Earphone/Monitor output:
Plug type: Mini
Impedance: 8/10k ohms
Output level:
0.775 V, 10k ohm load

Speaker Complement:

Built-in speaker, 2" diameter

Dimensions:

1 1/2" W x 5 7/8" H x 3 7/8" D
Unit Weight: 1 lb., 14 ozs.

SONY SUPERSCOPE®

You never heard it so good.

Model and specifications subject to change without notice.

 **FIDELITY SOUND COMPANY**

TC-40

Sony Model TC-40 Miniature Battery-Operated Action-Corder with Built-In Condenser Microphone

Small enough to fit snugly into one hand, the TC-40 features a built-in condenser microphone, which picks up anything your ears can hear with remarkably life-like fidelity.

FEATURES:

- Built-In Condenser Microphone
- Dual Differential-Balanced Flywheels eliminates variations in tape speed when unit is being carried
- Sonymatic Recording Control
- Servo-Control Motor
- End-of-Tape Alarm
- Record Level/Battery Strength Indicator
- Built-In Speaker
- Operates in Any Carrying Position
- Optional Stop/Start Microphone
- Optional Car Battery Operation



TC-40



TC-45

Sony Model TC-45 Deluxe Miniature Battery-Operated Action-Corder

with Built-In Condenser Microphone and Automatic Shut-Off

This is the world's finest miniature cassette recorder! Full of extra performance, value and dependability that's made Sony the first name in tape recorders, the exciting new TC-45 is ready to go places. So take it away!

FEATURES:

- Built-In Condenser Microphone
- Automatic Shut-Off
- Dual Differential-Balanced Flywheels
- Three-Digit Tape Counter
- Fast-Forward/Cueing
- Locking Rewind
- Pause Control with Lock
- Sonymatic Recording Control
- Servo-Control Motor
- Record Level/Battery Strength Indicator
- Built-In Speaker
- Operates in Any Carrying Position
- Optional Rechargeable Nickel-Cadmium Battery Pack/AC Power Supply
- Optional Car Battery Operation
- Optional Stop/Start Microphone

SONY **SUPERSCOPE**

You never heard it so good.®

 **FIDELITY SOUND COMPANY**

Sony/Superscope Monophonic Cassette-Corders.

From a miniature Cassette-Corder® that's small enough to carry in your attache case or purse to a full-size unit for audio-visual applications, there's a Sony Cassette-Corder® to fill every functional need. Whether you're a student, businessman or housewife, we make

a Cassette-Corder® that's perfect for you.

Just pop in a Sony tape cassette, press a button, and you're ready to listen. Nothing could be easier! All Sony Cassette-Corders® come with a Personal Earphone, Microphone, Carrying Case and blank Cassette. In addition, many models have

a Built-In Condenser Microphone and Dual Differential-Balanced Flywheels, which add a professional touch.

If you like to mix business with pleasure, we suggest that you pay particular attention to our new Cassette-Corder® AM/FM radio combinations. Besides all the things you use a

Cassette-Corder® for, you also get the added versatility of high-quality AM/FM reception, along with the ability to record cassettes right off the air.

It's your choice. Select your Sony Cassette-Corder® from the following models and put a little something "extra" into your life.



Sony Model TC-66 AC/DC Personal Portable Cassette-Corder®

The TC-66, our lowest-priced Cassette-Corder®, is perfect for budget-minded students and housewives, for personal correspondence, or just for fun. Here is famous Sony performance and dependability at an economical price.

FEATURES:

- AC/DC Operation
- Pushbutton Operation
- Locking Fast-Forward and Rewind Buttons
- Sonymatic Recording Control
- Microphone and Auxiliary Inputs
- Tone and Volume Controls
- Built-In Speaker
- Record Interlock
- Operates in Any Carrying Position
- Remote Stop/Start Microphone



Sony Model TC-70 AC/DC Portable Cassette-Corder® with Back-Space Review Button

For a few more dollars than a TC-66, the Sony TC-70 offers a unique Back-Space Review Button for "instant replay", and a Built-In Recharging Circuit for an Optional Nickel-Cadmium Battery Pack. These features, plus low-profile styling, make the TC-70 ideal for study and stenographic work.

FEATURES:

- Back-Space Review Button
- End-of-Tape Alarm
- Sonymatic Recording Control
- Microphone and Auxiliary Inputs
- Tone and Volume Controls
- Record Level/Battery Strength Indicator
- Operates in Any Carrying Position
- Optional Car Battery Operation
- Remote Stop/Start Microphone



Sony Model TC-90 AC/DC Portable Cassette-Corder® with Built-In Condenser Microphone

Here's a truly versatile performer! Sony's new TC-90 offers two microphones: a built-in professional condenser microphone for perfect "hands-off" recording, and a Remote Stop/Start Microphone for dictation and other uses where remote control is needed. Traditional Sony quality, rugged dependability, and outstanding performance make the TC-90 a truly outstanding value.

FEATURES:

- Back-Space Review Button
- Fast-Cueing
- Microphone and Auxiliary Inputs
- Record Interlock
- Sonymatic Recording Control
- Built-In Recharging Circuit for Optional Nickel-Cadmium Battery Pack
- Record Level/Battery Strength Indicator
- Tone and Volume Controls
- End-of-Tape Alarm
- Locking Fast-Forward and Rewind Buttons
- Operates in Any Carrying Position
- Optional Car Battery Operation

Sony Model TC-95 Executive Cassette-Corder® with Built-In Condenser Microphone

One step up from the TC-90, Sony's new TC-95 really gets down to business! The complete array of famous Sony convenience features, including Digital Tape Counter, Back-Space Review Button, Fast-Cueing, and Remote Stop/Start Microphone, makes the TC-95 ideal for dictation and transcription. Smart styling complements both desk top and conference table use.

FEATURES:

- Built-In Condenser Microphone
- Microphone and Auxiliary Inputs
- Record Interlock
- Sonymatic Recording Control
- Built-In Recharging Circuit for Optional Nickel-Cadmium Battery Pack
- Record Level/Battery Strength Indicator
- Tone and Volume Controls
- Automatic Shut-Off
- Locking Fast-Forward and Rewind Buttons
- Operates in Any Carrying Position
- Optional Car Battery Operation

 FIDELITY SOUND COMPANY

Monophonic
Cassette-Corders®
 Cont.

**Cassette-Corders® for
 Audio-Visual
 Applications**



**Sony Model TC-110A
 AC/DC Portable
 Cassette-Corder®
 with Built-In Condenser Microphone**

The popular, all-purpose TC-110A is the overwhelming choice of news correspondents and business executives! The Built-In Condenser Microphone eliminates "mike fright", because it's tucked away, out of sight. Handy for dictation purposes, a Back-Space Review Button and Three-Digit Tape Counter make it easy to transcribe cassettes. The TC-110A comes with a Remote Stop/Start Microphone.

FEATURES:

- Built-In Condenser Microphone
- Locking Fast-Forward and Rewind Buttons
- Built-In Recharging Circuit for Optional Nickel-Cadmium Battery Pack
- Sonymatic Recording Control
- Record Level/Battery Strength Indicator
- End-of-Tape Alarm
- Tone and Volume Controls
- Built-In Extended Range Speaker
- Operates in Any Carrying Position
- Optional Car Battery Operation

SUGGESTED ACCESSORIES:
 TB-1 Car Mounting Bracket.

**Sony Model TC-140
 Deluxe AC/DC Portable
 Cassette-Corder®
 with TMS and Built-In Condenser Microphone**

This Sony has a mind of its own! Thanks to Automatic Total-Mechanism Shut-Off (TMS), the new TC-140 turns itself completely off when it reaches the end-of-tape. The results? Longer battery life, less wear. Sonymatic Recording Control automatically adjusts and monitors the record level to assure perfect recordings every time. And Dual Differential-Balanced Flywheels eliminate variations in tape speed when the unit is being carried. Here's more style and performance than you can find in any other similar recorder!

FEATURES:

- TMS (Automatic Total-Mechanism Shut-Off)
- Dual Differential-Balanced Flywheels
- Sonymatic Recording Control
- Built-In Condenser Microphone
- Built-In Recharging Circuit for Optional Nickel-Cadmium Battery Pack
- Microphone and Auxiliary Inputs
- Record Level/Battery Strength Indicator
- Tone and Volume Controls
- Three-Digit Tape Counter

**Sony Model TC-95L
 Quarter-Track
 Cassette-Corder® Learning
 Laboratory
 for Audio-Visual Applications**

Want a tape recorder you can talk with? Sony's new TC-95L lets a person record questions on one channel of a cassette, allowing enough time after each question for a second person to respond. Then the second person can record his answers directly on the other channel, using either the included earphone and built-in condenser microphone, or optional Sony HS-23A microphone headset. Later on, each track can be played back—individually or together.

FEATURES:

- Unique Teacher/Student Balance Control for separate or simultaneous track playback
- LL/Normal Switch for separate recording of tracks
- Built-In Condenser Microphone
- Back-Space Review Button
- Fast-Forward/Fast-Cueing Button
- Microphone, Auxiliary Input, and Earphone Monitor Jacks
- Record Level/Battery Strength Indicator
- Large 4" Dynamic Speaker
- Three-Digit Tape Counter
- Sonymatic Recording Control
- Optional Car Battery Operation
- Operation in Any Carrying Position

**Sony Model TC-180AV
 Monophonic
 Cassette-Corder®
 for AV Applications**

Specially designed for audio-visual use, the new TC-180AV brings the simplicity of cassette recording and playback to educators and lecturers. A Built-In Extended-Range Speaker and powerful 5 Watt RMS amplifier fill even the largest room with full-fidelity sound. Solid-state circuitry assures dependable operation, year after year. The TC-180AV is housed in a rugged, impact-resistant case.

FEATURES:

- Public Address/Microphone "Override" lets you mix "live" voice into pre-recorded presentation
- Two-Position Monitor Level Switch
- Two Microphone Inputs
- Sonymatic Recording Control with Defeat Switch and VU Meter
- End-of-Tape Alarm
- Pause Control with Lock
- Three-Digit Tape Counter
- Tone and Volume Controls
- Safety-Approved Three-Wire AC Power Cord
- Price includes Connecting Cord, Dust Cover/Accessory Case, and Plug Adapter

Sony/Superscope Monophonic Cassette-Corders*

Models:	TC-40	TC-45	TC-55	TC-60A	TC-70	TC-90	TC-95	TC-95L	TC-110A	TC-140	TC-180AV*
FREQUENCY RESPONSE (Hz)	50-10K	50-10K	50-10K	150-8K	50-10K	50-10K	50-10K	50-10K	50-10K	50-10K	50-12K
POWER REQUIREMENTS	6 VDC	6 VDC	6 VDC	117 VAC., 6 VDC	117 VAC., 6 VDC	120 VAC., 4 WATTS, 50/60 Hz., 6 VDC	120 VAC., 6 WATTS, 50/60 Hz., 6 VDC	120 VAC., 6 WATTS, 50/60 Hz., 6 VDC	117 VAC., 6 VDC	120 VAC., 4.5 WATTS, 50/60 Hz., 6 VDC	117 VAC., 30 WATTS, 60 Hz., 6 VDC
DIMENSIONS WxHxD (Inches)	1 $\frac{5}{16}$ x7 x4 $\frac{3}{8}$	2x7 $\frac{1}{4}$ x4 $\frac{3}{8}$	1 $\frac{1}{2}$ x5 $\frac{7}{8}$ x3 $\frac{3}{8}$	5 $\frac{1}{8}$ x2 $\frac{5}{8}$ x9 $\frac{3}{4}$	8 $\frac{1}{16}$ x2 $\frac{5}{16}$ x8 $\frac{1}{4}$	5 $\frac{1}{16}$ x2 $\frac{11}{16}$ x10 $\frac{9}{8}$	9 $\frac{1}{16}$ x2 $\frac{3}{4}$ x8 $\frac{1}{4}$	9 $\frac{1}{16}$ x2 $\frac{3}{4}$ x8 $\frac{1}{4}$	5 $\frac{3}{4}$ x2 $\frac{1}{2}$ x9 $\frac{1}{2}$	10 $\frac{1}{4}$ x2 $\frac{5}{8}$ x5 $\frac{1}{16}$	12 $\frac{1}{16}$ x4 $\frac{11}{16}$ x11 $\frac{1}{16}$
WEIGHT	1 LB., 11 OZ.	2 LBS., 2 OZ.	1 LB., 14 OZ.	3 LBS., 8 OZ.	5 LBS., 1 OZ.	4 LBS., 14 OZ.	5 LBS., 9 OZ.	5 LBS., 9 OZ.	3 LBS., 13 OZ.	4 LBS., 14 OZ.	11 LBS., 1 OZ.
AD/DC OPERATION	A	A	A	•	•	•	•	•	•	•	
OPTIONAL RECHARGEABLE NI-CAD BATTERY PACK	•	•	•		•	•	•	•	•	•	
RECORD LEVEL/BATTERY STRENGTH INDICATOR	•	•	•		•	•	•	•	•	•	
BUILT-IN CONDENSER MICROPHONE	•	•	•			•	•	•	•	•	
SERVO-CONTROL MOTOR	•	•	•								
DUAL DIFFERENTIAL- BALANCED FLYWHEELS	•	•	•							•	
END-OF-TAPE ALARM	•				•	•		•	•		•
AUTOMATIC SHUT-OFF		•	•				•			TMS	
TAPE COUNTER		•	•				•	•	•	•	•
LOCKING PAUSE CONTROL		•	•								•
AUXILIARY INPUTS				•	•	•	•	•	•	•	•
REMOTE STOP/START MICROPHONE SUPPLIED				•	•	•	•	•	•	•	•
TONE CONTROL				•	•	•	•	•	•	•	•
BACK-SPACE REVIEW BUTTON					•	•	•	•	•		
BUILT-IN RECHARGING CIRCUIT					•	•	•	•	•	•	

A — Optional Rechargeable Nickel-Cadmium Battery includes AC Adapter

Each Sony Monophonic Cassette-Corder* has the following features: Sonymatic Recording Control, Record Interlock, Earphone Monitor Jack, Cassette Eject Button, Pushbutton Operation. Each is supplied with a Blank Cassette, Personal Earphone, Carrying Case, and Batteries (where applicable).

*The Sony Model TC-180AV features a Safety-Approved 3-Wire Power Cord, Two Microphone Inputs, Microphone Override, and Sonymatic Record Control Defeat Switch and VU Meter.



You never heard it so good®

 FIDELITY SOUND COMPANY

SONY/SUPERSCOPE

TC-126CS

AC/DC Portable Stereo Cassette-Corder[®] System



Now you can take the excitement of full-dimensional stereo everywhere you go! The new SONY TC-126CS AC/DC Portable Stereo Cassette-Corder combines pop-in, pop-out cassette convenience with outstanding performance. Separate the two plug-in, external speakers up to 15 feet for true, full-range stereo sound. With speakers disconnected, the TC-126CS turns into a true component-quality cassette deck, ideally suited for your home stereo system. This unique feature is the result of specially designed circuitry that includes both line input and line output jacks. For extra versatility, you can also use the TC-126CS as a portable monaural recorder. With speakers and microphone in place, the SONY TC-126CS is particularly effective in audio-visual applications. And there's never a power problem, because it operates on either 120-volt house current, internal batteries, rechargeable battery pack, or automobile cigarette lighter. In addition, the Model TC-126CS offers many special features.

Automatic Total-Mechanism Shut-Off (TMS) turns off the unit from any operating mode (record, play, fast-forward, or rewind) when the end of a cassette is reached. Dual Differential-Balanced Flywheels eliminate variations in tape speed when in play or record modes while the unit is being carried. Tape Select Switch lets you use either standard or new high-performance cassettes. There's also the added convenience of a Public Address System, Three-Digit Tape Counter, and Sonymatic Recording Control. For safe handling, a rugged attache-type carrying case is included. Full of traditional SONY quality and dependability, the Model TC-126CS AC/DC Portable Stereo Cassette-Corder System is a lot of sound in a little package.

ALSO AVAILABLE:
SONY TC-126 AC/DC Portable Cassette-Corder (same as TC-126CS but without external stereo speakers and attache-type case).

SO
AC

Thr
Tap
witl

Rec
Bat
Indi

Ster
Mor

Ton

Volt

Balk

SUF
F
M
C
A
R
S
E
E
V

REC
SON
C
C
C
U
U
C
B
D
F
M
R
Et
C

Sony/Superscope TC-126CS

AC/DC Portable Stereo Cassette-Corder® System

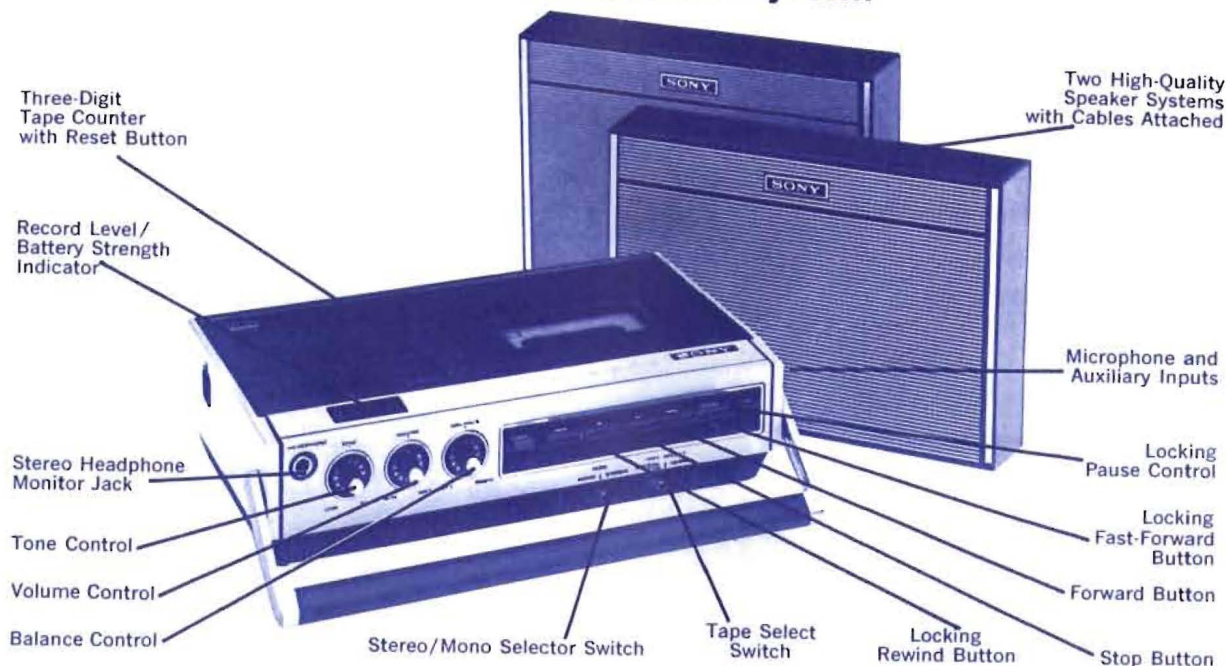

In addition to the features shown, the TC-126CS also includes Automatic Total-Mechanism Shut-Off (TMS), Dual Differential-Balanced Flywheels, Variable Monitor/Public Address System, Sonymatic Recording Control, Non-Magnetizing Record Head, Built-In Recharging Circuit for Nickel-Cadmium Battery Pack, Line Inputs and Line Outputs.

SUPPLIED ACCESSORIES:

- F-99S One-Point Stereo Stop/Start Microphone
- C-60 Cassette
- AC Power Cord
- RK-74 Patch Cord
- Size "C" Batteries (4)
- Soft Carrying Case
- Earphone
- External Speaker Systems (2)
- Vacuum-Formed Attache-Type Case

RECOMMENDED

SONY TAPE AND ACCESSORIES:

- CRO-60 Chromium Dioxide Cassette
- C-30, C-60, C-90, C-120 Auto-Sensor Cassettes
- UHF C-60, UHF C-90, UHF C-120 Ultra-High Fidelity Auto-Sensor Cassettes
- BP-16 Battery Pack
- DCC-126 DC Cord
- FS-6 Foot Switch
- MX-6S Mixer
- RM-15 Remote Control
- ECM-99 One-Point Stereo Stop/Start Condenser Microphone

SPECIFICATIONS:

- Power Requirements:** 120 volts AC, 7 Watts 60 Hz, (50 Hz optional); 6 volts DC
- Battery size and quantity:** Size "C" (4)
- Battery life:** 4.5 Hours Continuous (Record Mode)
- Tape Speed:** 1 7/8 ips
- Reel Size:** Cassette
- Recording System:** Quarter-Track Stereo
- Rewind and Fast-Forward Time:** 80 sec./C-60
- Frequency Response:** Standard Tape: 50 Hz to 10 kHz
Chromium Dioxide Tape: 50 Hz to 13 kHz
- Signal-to-Noise Ratio:** Standard Tape: 45 dB
Chromium Dioxide Tape: 45 dB
- Bias Frequency:** 85 kHz
- Type of Level Indication:** Record Level/Battery Strength Indicator
- Power Output:** 1.5 Watts IHF Dynamic Power/Channel
- Head Configuration:** 1 Half-Track Erase
1 Quarter-Track Record/Playback
- Wow and Flutter:** 0.26% @ 1 7/8 ips
- Number and Type of Motor:** 1 Governor-Controlled DC

Input:

- 2 Auxiliary (one for each channel):
Plug Type: Phono
Impedance: 100k ohms
Input Sensitivity: 0.06 V
- 2 Microphone (one for each channel):
Plug Type: Mini
Impedance: Low
Input Sensitivity: -72 dB
(can be used as a magnetic phono input with optional RK-66 adapter)

Output:

- 2 Line (one for each channel):
Plug Type: Phono
Impedance: 10k ohms
Output Level: 0.775 V at Zero VU
- 2 Lid Speakers (one for each channel):
Plug Type: Mini
Impedance: 8 ohms
Output Power: 1.5 Watts/Channel
- 1 Stereo Headphone Jack:
Plug Type: Binaural Phone Jack
Impedance: 8 ohms

Speaker Complement:

- Built-in speaker, 4" x 3"
- 2 External Speakers, type 4" (TC-126CS only)

Dimensions: 10 7/8" W x 3 1/16" H x 7 3/8" D

Unit Weight: 6 lbs., 10 ozs.

Model and specifications subject to change without notice.

SONY SUPERSCOPE®

You never heard it so good.

 **FIDELITY SOUND COMPANY**

Stereo Cassette Decks

Ste
wit

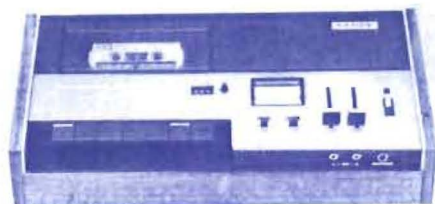

Sony Model TC-122 Economy Stereo Cassette Deck

This is our least expensive stereo cassette deck. If your budget won't allow any frills, look no further. The TC-122 has many of the features of higher priced decks at a price you can afford. Plus fabulous Sony quality and outstanding stereo fidelity.

FEATURES:

- Sonomatic Recording Control
- Dual Level Meters
- Pushbutton Operation
- Tape Pilot Lamp indicates operating mode at a glance
- Tape Select Switch for standard and new Chromium Dioxide Cassettes
- Stereo Headphone Jack
- Walnut Base
- Locking Fast-Forward and Rewind Buttons
- Microphone and Auxiliary Inputs

Sony Model TC-127 Stereo Cassette Deck

An excellent choice for today's advanced stereo enthusiast, the TC-127 is our medium-priced stereo cassette deck. With features like professional straight-line record level controls, the TC-127 adds high-performance to cassette convenience. A great addition to your stereo system!

FEATURES:

- Built-In Peak Limiter for Distortion-Free Recording
- Tape Select Switch for standard and new Chromium Dioxide Cassettes
- Dual Professional-Type VU Meters
- Three-Digit Tape Counter
- Pause Control with Lock
- Stereo Headphone Jack
- Microphone and Auxiliary Inputs

Sony Model TC-165 Automatic Reverse Stereo Cassette Deck

This exciting model *doubles* the convenience of cassettes! The TC-165's Automatic Reverse provides continuous recording and playback in both directions. Which means you don't have to flip over a cassette to hear what's on the other side.

FEATURES:

- Automatic and Manual Reverse in recording and playback modes
- Closed-Loop Dual Capstan Tape Drive for lowest wow and flutter
- Automatic Shut-Off at end of each cycle or Continuous Play
- Straight-Line Record Level Controls
- Built-In Peak Limiter for distortion-free recording
- Tape Select Switch for Standard and new Chromium Dioxide Cassettes
- Stereo Headphone Jack with Two-Position Headphone Level Switch
- Three-Digit Tape Counter
- Calibrated, Illuminated VU Meters

Sony Model TC-165 Deluxe Stereo Cassette Deck

With no pleasure in reducing performance, the TC-165's Ferrite Head provides longer life than other cassettes. Shut-Off any modulating tone.

FEATURES:

- Tri-Track
- Distortion-Free
- Stereo
- Professional-Type
- VU Meters
- Three-Digit
- Tape Counter
- Calibrated, Illuminated
- VU Meters

Stereo Cassette Decks with Dolby* System



Sony Model TC-134SD Deluxe Stereo Cassette Deck with Dolby Noise Reduction System, Ferrite and Ferrite Head, and Automatic Total-Mechanism Shut-Off (TMS)

With no annoying tape hiss to mar your listening pleasure, the TC-134SD's highly refined Dolby* Noise Reduction System makes for the quietest cassette performance ever. The precision-molded Ferrite and Ferrite Head, a Sony exclusive, lasts up to 200 times longer than a permalloy head and provides exceptional sound fidelity with new Chromium Dioxide cassettes. At end-of-tape, Automatic Total-Mechanism Shut-Off (TMS) turns the unit completely off—in any mode—reducing machine wear as well as eliminating the need for constant monitoring.

FEATURES:

- Three-Digit Tape Counter with Reset Button
- Dual VU Meters
- Straight-Line Record Level Controls
- Peak Limiter prevents distortion from unexpected volume peaks while recording
- Tape Select Switch for standard and new Chromium Dioxide cassettes
- Pause Control with Lock
- Stereo Headphone Jack

Sony Model TC-161SD Advanced Stereo Cassette Deck with Dolby Noise Reduction System, Ferrite and Ferrite Head, Memory Tape Counter, and Automatic Total-Mechanism Shut-Off (TMS)

Here's the most advanced stereo cassette deck on the market! The TC-161SD's Dolby* Noise Reduction System lets you enjoy the cleanest sound this side of the concert hall. And Closed-Loop Dual Capstan Tape Drive assures constant tape tension against the exclusive Ferrite and Ferrite Head for better all-around performance. As even more evidence of Sony's technical wizardry, the TC-161SD's Ferrite and Ferrite Head is a precision-molded, single piece of ferrite. What's more, the new Memory Tape Counter locates any desired selection on a cassette.

FEATURES:

- Memory Tape Counter
- Tape Select Switch for standard and new Chromium Dioxide cassettes
- Straight-Line Record Level Controls
- Peak Limiter prevents distortion from unexpected volume peaks while recording
- Pause Control with Lock
- Locking Fast-Forward and Rewind
- Hysteresis Synchronous Motor for extremely accurate tape speed
- Illuminated Cassette Compartment
- Stereo Headphone Jack with Two-Position Headphone Level Switch

*Dolby and Dolby System are trademarks of Dolby Laboratories, Inc.

8-Track Stereo Cartridge Recorder and Playback



Sony Model TC-228 Eight-Track Stereo Cartridge Recorder and Playback Deck

Get around the high cost of today's pre-recorded cartridges by recording your own cartridge library on the new Sony TC-228 Eight-Track Stereo Cartridge Recorder and Playback Deck. In fact, if you record your favorite music on as few as thirty blank cartridges, you'll save the entire cost of owning the TC-228! With many exclusive Sony features, including full playback capability, here is the ultimate in eight-track versatility and performance.

FEATURES:

- TMS (Automatic Total-Mechanism Shut-Off)
- Manual Recording Level Controls
- Automatic and Manual Program Selection
- Three-Way Eject System
- Automatic AC System Shut-Off
- Two Illuminated VU Meters
- Fast-Forward
- Pause Control with Lock
- Front Panel Microphone Input Jacks
- Automatic AC System Shut-Off
- Auxiliary Input and Line Output Jacks
- Non-Magnetizing Record Head
- Stereo Headphone Monitor Jack
- Price includes Head-Cleaning Pen and Stereo Patch Cord

 **FIDELITY SOUND COMPANY**

Car Stereo Cassette Players

Sony/Superscope Stereo Cassette and Cartridge Recorders

Talk about convenience, just add a Sony cassette deck to your stereo system. Simply pop in a cassette and you're ready to record or listen to your favorite music. Nothing could be easier.

Want your stereo to go places? A portable Sony Cassette-Corder® stereo system is something you can take along everywhere!

For car owners, a Sony car stereo cassette player will enhance your driving pleasure with superb sound. And exclusive Insta-Load cassette loading allows effortless, distraction-free operation for safe driving. (Motorists whose cars are already equipped with an eight-track stereo cartridge unit will find Sony's TC-228 stereo cartridge recorder and playback deck ideal for taping their own library of stereo eight-track cartridges for automobile and home listening.)

So if you're a stereo lover, searching for the ultimate in cassette sound, check out the following flawlessly-performing models. There's a Sony/Superscope Cassette-Corder® waiting for you, tailored to your personal requirements.



Sony Model TC-10 Car Stereo Cassette Player

Enhance your driving pleasure with the superb sound of the new Sony TC-10. Special features like Single-Action Cassette Loading and Automatic Cassette Eject allow effortless, hands-off, distraction-free operation for safe driving. Full of famous Sony quality and dependability, the TC-10 delivers a powerful 12 Watts RMS (6 per channel).

FEATURES:

- Single-Action Cassette Loading
- Automatic and Manual Eject
- Individual Tone, Volume and Balance Controls
- TMS (Automatic Total-Mechanism Shut-Off)
- Locking Fast-Forward and Rewind
- 12 Watts RMS (6 per channel)
- Attractive black with silver trim styling
- Easily installed in any automobile with 12-volt negative ground electrical system
- Price includes Car Mounting Bracket, Hardware, Head-Cleaning Pen, and Spare Fuse.

SUGGESTED ACCESSORIES:

Sony SS-1, SS-10 and SS-11 Car Speakers.



Sony Model TC-20 Car Stereo Cassette Player

Here's a good one for the road! Our TC-20 stereo cassette player has 12 Watts of total RMS power. Single-Action Cassette Loading and Automatic Cassette Eject permit completely distortion-free listening pleasure. The Model TC-20 is compatible with any automobile with 12-volt negative ground electrical system.

FEATURES:

- Pushbutton Operation
- Stereo Balance Control
- Tone and Volume Controls
- Price includes Car Mounting Bracket, Hardware and Head-Cleaning Pen

SUGGESTED ACCESSORIES:

Sony SS-1, SS-10 and SS-11 Car Speakers.



Sony Model TC-30 Deluxe Car Stereo Cassette Player with Automatic Reverse

Tired of stop-and-go stereo? The new Sony TC-30 adds the enjoyment of continuous, non-stop stereo playback to your driving. Thanks to Automatic-Reverse, you don't have to flip over a cassette to hear what's on the other side. Many more deluxe Sony features, plus 12 Watts of RMS power (6 per channel), provide exceptional convenience and performance.

FEATURES:

- Continuous Automatic-Reverse
- Dual-Capstan Tape Drive
- Tape Pilot Directional Lamp
- Individual Tone, Volume and Balance Controls
- Insta-Load Cassette Loading
- Locking Fast-Forward and Rewind
- Manual Eject
- Dual Differential-Balanced Flywheels
- Easily installed in any automobile with 12-volt negative ground electrical system
- Price includes Spare Fuse and Mounting Hardware

SUGGESTED ACCESSORIES:

Sony SS-1, SS-10 and SS-11 Car Speakers.

Sony/Superscope Stereo Cassette Tape and Cartridge Recorders/Players

Models:	TC-122	TC-127	TC-131SD	TC-161SD	TC-165	TC-228	TC-10	TC-20	TC-30	TC-124CS	TC-126CS
FREQUENCY RESPONSE (Hz)	40-10K	30-12K	30-17K	20-18K	30-14K	30-13K	50-10K	50-10K	50-10K	50-10K	50-10K
WOW AND FLUTTER (%)	0.22	0.2	0.2	0.1	0.1	0.17	0.25	0.28	0.25	0.28	0.26
SIGNAL TO NOISE (dB)	45	48	59	59	49	45	45	45	50	45	45
POWER REQUIREMENTS	117 VAC., 5 WATTS, 50/60 Hz.	117 VAC., 14 WATTS, 60 Hz.	120 VAC., 15 WATTS, 60 Hz.	120 VAC., 22 WATTS, 60 Hz.	117 VAC., 16 WATT, 60 Hz.	120 VAC., 40 WATT, 60 Hz.	12 VDC.	12 VDC 15 WATTS	12 VDC	117 VAC., 4 WATTS, 6 VDC	120 VAC., 7 WATTS, 6 VDC
Microphone Input PLUG TYPE	MINI	MINI	MINI	MINI	MINI	MINI				MINI	MINI
IMPEDANCE	LOW	LOW	LOW	LOW	LOW	LOW				LOW	LOW
Auxiliary Input PLUG TYPE	PHONO	PHONO	PHONO	PHONO	PHONO	PHONO				MINI	PHONO
IMPEDANCE (Ohms)	560K	100K	100K	100K	100K	100K				100K	100K
SENSITIVITY (Volts)	0.06	0.06	0.06	0.06	0.06	0.07				0.06	.06
Output PLUG TYPE	PHONO	PHONO	PHONO	PHONO	PHONO	PHONO	PIGTAIL	PIGTAIL	PIGTAIL	MINI	MINI
IMPEDANCE (Ohms)	10K	10K	10K	10K	10K	100K	3.2	3.2	3.2	8	8
LEVEL	0.775 V	0.775 V	0.775 V	0.775 V	0.775 V	0.5 V	12 WATTS, RMS	12 WATTS, RMS	12 WATTS, RMS	1 WATT, RMS/CH	1.5 WATTS, RMS/CH
DIMENSIONS WxHxD (Inches)	11 $\frac{7}{8}$ x3 $\frac{1}{8}$ x8 $\frac{1}{16}$	16 $\frac{1}{4}$ x4 $\frac{3}{16}$ x8 $\frac{1}{16}$	16 $\frac{1}{2}$ x4 $\frac{3}{16}$ x8 $\frac{1}{16}$	15 $\frac{3}{4}$ x5x10 $\frac{7}{8}$	15 $\frac{3}{4}$ x5x10 $\frac{7}{8}$	14 $\frac{1}{16}$ x4 $\frac{3}{4}$ x8 $\frac{3}{4}$	7 $\frac{3}{16}$ x2 $\frac{3}{8}$ x7 $\frac{1}{16}$	7 $\frac{3}{16}$ x2 $\frac{7}{8}$ x8 $\frac{1}{4}$	7 $\frac{1}{4}$ x2 $\frac{1}{16}$ x9 $\frac{3}{8}$	6 $\frac{1}{16}$ x2 $\frac{1}{16}$ x9 $\frac{3}{4}$	10 $\frac{7}{8}$ x3 $\frac{1}{16}$ x7 $\frac{3}{8}$
WEIGHT	6 LBS., 3 OZ.	10 LBS., 9 OZ.	10 LBS., 3 OZ.	14 LBS., 4 OZ.	15 LBS., 7 OZ.	11 LBS., 3 OZ.	4 LBS., 7 OZ.	7 LBS.	6 LBS., 10 OZ.	5 LBS.	6 LBS., 10 OZ.
DOLBY*			•	•							
SONYMATIC RECORDING CONTROL	•									•	•
STEREO HEADPHONE MONITOR JACK	•	•	•	•	•	•				•	•
RECORD LEVEL INDICATOR (VU)	•	•	•	•	•	•				•	•
TAPE COUNTER		•	•	•	•	•					•
MANUAL RECORDING CAPABILITY		•	•	•	•	•					
PAUSE CONTROL		•	•	•	•	•					•
AUTOMATIC TOTAL-MECHANISM SHUT-OFF			•	•	•	•	•	•			•

*Dolby and Dolby System are trademarks of Dolby Laboratories, Inc.

 FIDELITY SOUND COMPANY

MONAURAL BATTERY/AC RECORDER

The Sony 800-B

ServoControl Portable with Built-in Condenser Microphone

This deluxe functional portable features Sony's revolutionary built-in electret condenser microphone. It picks up sound from all directions with astonishing clarity. And it can be used simultaneously with the 800-B's external mike. It also has an extra slow fourth speed for up to eight hours of recording on a single reel. And the tape speed can be tuned to any musical instrument. The solid-state Model 800-B is the finest, most

versatile portable recorder ever designed for business or pleasure.

SPECIFICATIONS:

Frequency response 30-18,000 Hz @ 7 1/2 ips, 30-13,000 Hz @ 3 3/4 ips, 30-7,000 Hz @ 1 7/8 ips, 30-4,000 Hz @ 1 1/4 ips. Wow/flutter 0.1% @ 7 1/2 ips, 0.15% @ 3 3/4 ips, 0.2% @ 1 7/8 ips. Signal-to-noise ratio 48 db. Size and weight, 12 1/4" x 4 3/4" x 10 1/4"; 11 lbs., 13 oz.

SONY MODEL 800-B.

Includes external Sony remote stop/start cardioid dynamic microphone, personal

earphone, batteries

SUGGESTED ACCESSORIES:

LC-8B Carrying Case. DCC-2AW Auto Cigarette Lighter Adapter. RK-66 Magnetic Phono Adapter. TP-5S Telephone Pick-up. FS-6 Foot Switch. HE-2 Head Demagnetizer.



Features:

- Built-in electret condenser microphone
- Four tape speeds.
- ServoControl motor.
- Built-in VariSpeed tuning.
- Two-position Sonymatic recording control
- VU meter and Sonymatic defeat switch for manual recording.
- External stop/start cardioid dynamic microphone.
- Three-position microphone mode panel switch.
- Five-inch reel capacity.
- Two-track.
- Digital tape counter.
- Tone control.

FOUR TAPE SPEEDS 7 1/2, 3 3/4, 1 7/8, & 15/16 ips.

 FIDELITY SOUND COMPANY

Sony/Superscope Reel to Reel Recorders Monophonic

Sony Model TC-105A Deluxe Quarter-Track Monophonic Tape Recorder

With more features and performance than any other competitively-priced tape recorder, our all-purpose, AC-powered TC-105A will help make your work easier. Offering virtually automatic operation and famous Sony quality, the TC-105A is a favorite among students, teachers and businessmen alike for its outstanding value.

FEATURES:

- 7½, 3¾, and 1½ ips speeds
- 7-inch Reel Capacity for up to 16 hours of recording and playback
- Sonymatic Recording Control with Defeat Switch and VU Meter
 - Retractable Pinch Roller for quick, easy threading
 - Powerful Solid-State Amplifier
 - Pause Control with Lock
 - Three-Digit Tape Counter
 - Speaker Monitor Switch
 - Public Address Capability
- Safety-Approved 3-Wire AC Power Cord
- Price includes Dynamic Microphone and Personal Earphone



Sony Model TC-106AV Half-Track Monophonic Tape Recorder for AV Applications

From the classroom to the conference room to the lecture hall, the reel-to-reel TC-106AV half-track recorder brings rugged construction, dependable service, and outstanding performance to every audio-visual application. The TC-106AV features a powerful 5 watt (RMS) amplifier with a large extended-range speaker, to provide clear, room-filling sound.

FEATURES:

- 7½, 3¾, and 1½ ips speeds
- Sonymatic Recording Control with Defeat Switch and VU Meter
 - Automatic Tape Lifters
 - Retractable Pinch Roller
 - Two-Position Monitor Level Switch
 - Pause Control with Lock
 - Microphone and Auxiliary Inputs
 - Three-Digit Tape Counter
 - Speaker Monitor Switch
 - Safety-Approved 3-Wire AC Power Cord
- Price includes Dynamic Microphone, Personal Earphone, Empty 7-inch Reel



Stereo Tape Systems



Sony Model TC-353 Economy Three-Head Stereo Tape System with Lid-Integrated Speakers

A significant advance in portable reel-to-reel systems, the TC-353 offers a multitude of sophisticated features found only in much more expensive recorders. Like three-head design, for professional performance and the convenience of tape/source monitoring. Separate record and playback amplifiers, for increased frequency response. Built-in sound-on-sound and echo, for a variety of studio-type effects. And much more. In one easy-to-afford package, here is everything you need for top-quality home and away-from-home recording.

FEATURES:

- Three Heads for Tape/Source Monitoring
- 7½, 3¾ and 1½ ips Speeds
- Vibration-Free Motor
- Stereo Control Center
- Built-in Reel Locks
- Public Address Capability
- Record Equalization Selector Switch for standard or Sony SLH-180 low-noise, high-output recording tape
- Two VU Meters
- Scrape Flutter Filter
- Straight-Line Playback Level Controls
- Automatic Shut-Off
- Price includes two F-25 Dynamic Microphones, two RK-74 Stereo Patch Cords, Head Cleaning Ribbon, Empty 7-inch Reel, and SLH Tape Sample



Sony Model TC-630 Deluxe Stereo Tape System/Control Center

If you're a recording perfectionist, here is Sony's finest complete stereo tape system. For a surprisingly low price, the TC-630's remarkable array of features will satisfy the most advanced audio hobbyist. And 40 watts of dynamic music power, plus excellent frequency response will delight the serious listener. For a complete music system, just add a stereo tuner and record changer!

FEATURES:

- Three Heads for Tape/Source Monitoring
- Built-In Sound-on-Sound and Echo
- Professional Straight-Line Graphic Level Controls
- Magnetic Phono, Tuner, and Auxiliary Inputs
- Large, Illuminated VU Meters, Calibrated to NAB Standards
- Vibration-Free Motor
- Four-Digit Tape Counter
- Ultra-High Frequency Bias
- Stereo Balance Control, Tone and Volume Controls
- Stereo Headphone Jack
- Vertical/Horizontal Operation
- Pause Control with Lock
- Lid-Integrated, Full-Range Stereo Speakers
- Noise Suppressor Switch
- Speaker Mode Selector Switch
- Scrape Flutter Filter for distortion-free performance
- Price includes two Dynamic Microphones, Empty 7-inch Reel, RK-74 Stereo Patch Cord, two Reel Caps, AC Power Cord, and Head Cleaning Ribbon

 **FIDELITY SOUND COMPANY**

STEREO TAPE SYSTEM

The Sony 252

Budget Portable Stereo System

For the budget-minded music-lover, here is the most tape recorder for the money. Lightweight, compact, the Sony 252 is a complete portable solid-state four-track stereo tape system that incorporates many features formerly found only on larger, more expensive models. It offers sound-with-sound, sound-on-sound, built-in amplifiers, and two full-range

lid-integrated stereo speakers that provide a remarkably rich, exceptionally beautiful sound.

SPECIFICATIONS:
Frequency response 40-18,000 Hz @ 7½ ips, 40-13,000 Hz @ 3¾ ips, 40-7,000 Hz @ 1⅞ ips. Wow/flutter 0.12% @ 7½ ips, 0.15% @ 3¾ ips, 0.20% @ 1⅞ ips. Signal-to-noise ratio 50 db. Size and weight, 16¼" x 10¼" x 15" 29 lbs., 13 oz.

SONY MODEL 252.
Complete with two Sony F-25

cardioid dynamic microphones

SUGGESTED ACCESSORIES:
MX-6S Stereo/Mono Mixer. TP-5S Telephone Pick-up. RK-66 Magnetic Phono Adapter. DR-6A Stereo Headphone. HE-2 Head Demagnetizer.



- Records & plays individual monophonic tracks or stereo.

Features:

- Sound-on-sound.
- Stereo headphone jack.
- Vibration-free motor.
- Speaker monitor switch.
- Scrape flutter filter.
- Pause control.
- Vertical/horizontal operation.

 **FIDELITY SOUND COMPANY**

Sony/Superscope Stereo Reel-to-Reel Tape Decks

Sony/Superscope offers a complete selection of reel-to-reel tape decks in every price range for you to choose from. Each model offers the incomparable engineering excellence and quality which has made Sony the most sought-after recorder in the world. (Each deck comes with an empty take-up reel and connecting patch cords, too.) Of course, the more sophistication and features you need, the more the deck will cost. It's that simple.

And while we're making things easy, you should also know why a reel-to-reel deck will deliver better sound quality than its cassette counterpart.

Reel-to-reel tape is twice as wide (1/4" vs. 1/8") and has the capability to move at higher speeds than cassette tape does. This means recorded sound on reel-to-reel tape is "spread out" over a greater surface area, insuring unmatched frequency response, dynamic range, stereo separation, and a better signal-to-noise ratio.

If you're the creative type, here's something else to remember: only with reel-to-reel can you easily edit or add special effects like sound-on-sound and echo, plus have the versatility of multiple tape speeds.

Now, find the Sony/Superscope reel-to-reel deck that's just right for you . . . and your stereo system.

ACCESSORIES:

For complete listing of all Sony/Superscope accessories, please refer to Accessories Brochure.

TC-377

Sony Model TC-377 Deluxe Three-Head Stereo Tape Deck with Automatic Total-Mechanism Shut-Off (TMS)



Similar in appearance to the TC-366, the new TC-377 offers a host of extra performance and convenience features, like Microphone Attenuator Switch, Long-Life Ferrite and Ferrite Heads, and Variable Line Output, and more.

FEATURES:

- TMS (Automatic Total-Mechanism Shut-Off)
- Microphone Attenuator Switch
- Long-Wearing Ferrite and Ferrite Heads for Ultra-High Performance
- Variable Line Output
- Reversible Slanted Walnut Base provides the perfect angle for either Horizontal or Vertical Operation
- Ultra-High Frequency Bias
- Pause Control with Lock
- Three-Heads for Tape/Source Monitoring and wider Frequency Response
- Servo-Controlled Tape Tension
- Vibration-Free Motor
- Sound-on-Sound Capability
- Record Equalization Selector Switch allows optimum performance with either standard tape or Sony low-noise, high-output tape
- Two VU Meters
- Four-Digit Tape Counter



Sony Model TC-252D Solid-State Stereo Tape Deck

If you're on a limited budget, our lowest priced stereo reel-to-reel tape deck, the quarter-track TC-252D is loaded with many features from more expensive machines. For example, you get a Retractable pinch roller for easy one-hand threading; Automatic Shut-Off at end of tape; Automatic Tape Lifters, which protect heads from wear during fast rewind; Stereo Headphone Monitor Jack for private listening; and much more. A really spectacular buy!

FEATURES:

- Sound-with-Sound
- Sound-on-Sound Capability
- Three Speeds
- Vibration-Free Motor
- Built-In Reel Locks
- Two VU Meters
- Pause Control with Lock
- Three-Digit Tape Counter
- Vertical or Horizontal Operation
- Walnut Base



Sony Model TC-353D Economy Three-Head Stereo Tape Deck

For only a few dollars more than the TC-252D, the added flexibility of a three-head deck is yours! The TC-353D's three-head design lets the user check the quality of a new recording while the recording is in progress. In addition, a Record Equalization Selector Switch allows optimum performance with either standard tape or Sony low-noise, high-output tape. Simplified controls make perfect recording

FEATURES:

- Ultra-High Frequency Bias
- Vibration-Free Motor
- Pause Control with Lock
- Sound-on-Sound Capability
- Two VU Meters
- Three Speeds
- Vertical or Horizontal Operation
- Microphone/Line Mixing

 **FIDELITY SOUND COMPANY**



Sony Model TC-440
Automatic Reverse Stereo Tape Deck
 with Roto Bi-Lateral Head

This is our economy reversing deck. With the new TC-440, you'll never have to flip a reel over again! A unique Roto Bi-Lateral Head revolves 180 degrees, to permit recording, monitoring and playback in both directions. But the TC-440 offers you more than convenience and low price. Extremely high performance is assured thanks to Closed-Loop Dual Capstan Tape Drive, a Servo-Control Motor, and other unique professional features.

FEATURES:

- Foil-Activated Automatic Reverse
- Automatic Total-Mechanism Shut-Off
- Built-In Sound-on-Sound and Echo
- Electrical Speed Change
- Microphone/Line Mixing
- Record Equalization Selector Switch
- FET Amplifier
- Servo-Controlled Back Tension
- Ultra-High Frequency Bias
- Two VU Meters
- Four-Digit Tape Counter



Sony Model TC-650
TC-650-2
TC-650-4
Professional Quality Three-Head,
Three-Motor Stereo Tape Deck

Behind the illuminated, color-coded pushbutton controls of the TC-650, you'll discover a full array of impressive professional features! For example, Solenoid-Operated, Logic Controlled Transport Functions make it impossible for you to ever break a tape again. And an optional plug-in head block assembly lets you switch easily from quarter-track to two-track operation.

FEATURES:

- Microphone/Line Mixing
- Built-In Sound-on-Sound and Echo
- Hysteresis Synchronous Capstan Motor
- Microphone and Auxiliary Inputs
- Plug-In Head Block Assembly
- Die-Cast Tape Guide and Head Block Mounting Frame
- Large, Illuminated VU Meters, calibrated to NAB Standards
- Defeatable Tape Lifters for easy editing and high-speed cueing
- Four-Digit Tape Counter
- Record Equalization Selector Switch allows optimum performance with either standard tape or Sony low-noise, high-output tape
- Precision Balanced Capstan and Impedance Flywheels
- Scrape Flutter Filter
- Built-In Reel Locks
- Modular Plug-In Electronics

SUGGESTED ACCESSORIES:

H-17-2S Two-Track Plug-In Head Block Assembly;
 H-17-4S Quarter-Track Plug-In Head Block Assembly;
 RM-16 Full-Function Remote Control.



Sony Model TC-640 Three-Head,
Three-Motor Stereo Tape Deck

Ideal for mounting in bookshelves and other limited-space areas, the compact TC-640 is basically a simplified version of our exotic TC-650. At a moderate price, here are enough sophisticated features and performance to satisfy the most advanced stereo buff. Bold, distinctive styling will make it the main attraction in your stereo system.

FEATURES:

- Unique Lever-Action Transport Control
- Solenoid-Operated Transport Functions
- Die-Cast Tape Guide and Head Block Mounting Frame
- Hysteresis Synchronous Capstan Motor and Outer Rotor Reel Drive Motors
- Four-Digit Tape Counter
- Built-In Sound-on-Sound and Echo
- Microphone/Line Mixing
- Mechanical Memory Capability permits timer-activated record, playback, and stop modes
- Hyperbolic Heads require no pressure pads
- Record Equalization Selector Switch allows optimum performance with standard tape or Sony low-noise, high-output tape
- Large, Illuminated VU Meters Calibrated to NAB Standards
- Pause Control
- Built-In Reel Locks
- Scrape Flutter Filter
- SLH Tape Sample Included

FIDELITAPE FOOTPEDAL

START / STOP / BACKSPACE

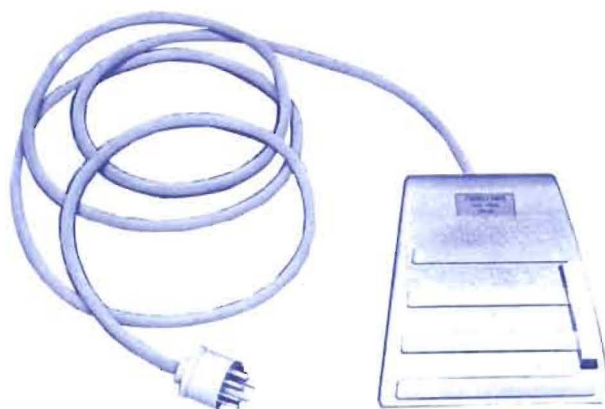

Sony Model TC-580 Professional-Quality Automatic Reverse Stereo Tape Deck with Electro Bi-Lateral Heads

If you demand the finest in auto-reverse stereo tape deck performance, here is the state-of-art! The deluxe three-motor TC-580 incorporates exclusive Electro Bi-Lateral Heads and ESP Automatic Reverse which provide continuous bi-directional playback. All specifications and features of this exciting new deck meet the most demanding professional standards.

FEATURES:

- Automatic Total-Mechanism Shut-Off
- Center Capstan Tape Drive
- Three Motors
- Record Equalization Selector Switch allows optimum performance with either
- Standard tape or Sony low-noise, high-output tape
- Sound-on-Sound Capability
- Feather-Touch Control Buttons
- Servo-Control Capstan Motor
- Ultra-High Frequency Bias
- Two-Position Headphone Monitor Switch
- Large, Illuminated VU Meters, Calibrated to NAB Standards
- Four-Digit Tape Counter
- Built-In Reel Locks
- Microphone/Line Mixing
- Price includes Molded Plastic Dust Cover

TC 850 (850-2 & 850-4)



Sony Model TC-850 Professional Quality Three-Motor Stereo Tape Deck with 10 1/2" Reel Capacity

The TC-850 is the top of our line — the finest component stereo tape deck you can buy! Besides two giant 10 1/2" reels for maximum record and playback time, the TC-850 incorporates every imaginable feature. For example, the Automatic Program Scanner locates and plays individual segments of music and eliminates rethreading. The TC-850 is available in both two-track and quarter-track versions, and has an additional playback head for both two-track and quarter-track playback. Here is the perfect nucleus of the most sophisticated stereo system!

FEATURES:

- Closed-Loop Dual Capstan Drive provides lowest wow and flutter
- Die-Cast Tape Guide and Head Block Mounting Frame
- Record Equalization Selector Switch allows optimum performance with either standard tape or Sony low-noise, high-output tape
- Logic-Controlled Transport Functions for perfect tape handling characteristics
- Defeatable Tape Lifters
- 15, 7 1/2 and 3 3/4 ips Tape Speeds
- Four-Digit Tape Counter
- Fourth Head for Two-Track and Quarter-Track Playback
- Three-Motor Transport with ServoControl Capstan Motor
- Automatic Shut-Off
- Modular Construction
- Fully Accessible Bias and Equalization Adjustments
- Front Panel Sound-on-Sound and Echo Control
- Large, Illuminated VU Meters, Calibrated to NAB Standards
- NAB Hub Adapters and SLH Tape Sample Included

SUGGESTED ACCESSORIES:

H-60-21S Two-Track Plug-In Head Block Assembly;
H-60-41S Quarter-Track Plug-In Head Block
Assembly; RM-16 Full-Function Remote Control;
MB-8 19" Rack Mount Frame.

 **FIDELITY SOUND COMPANY**

Sony/Superscope Stereo Reel-to-Reel Tape Decks

Models:	TC-252D	TC-353D	TC-440	TC-640	TC-580	TC-650-2	TC-650-4	TC-850-2	TC-850-4	
FREQUENCY RESPONSE @ 15 ips. (Hz)								30-25K*	30-25K*	
FREQUENCY RESPONSE @ 7½ ips. (Hz)	30-18K	30-25K**	30-25K**	30-20K**	30-25K**	30-22K*	30-22K*	30-22K*	30-22K*	
FREQUENCY RESPONSE @ 3¾ ips. (Hz)	40-13K	30-17K	20-23K	30-18K	30-20K	40-15K*	40-15K*	40-15K*	40-15K*	
FREQUENCY RESPONSE @ 1¾ ips. (Hz)		30-8K	30-9K		30-9K					
WOW AND FLUTTER (%)	0.12	0.12	0.06	0.07	0.06	0.04	0.04	0.03	0.03	
SIGNAL TO NOISE RATIO (dB)	52	55	56	55	56	59	57	57	57	
MICROPHONE INPUT PLUG TYPE	MINI	MINI	MINI	PHONE	PHONE	PHONE	PHONE	PHONE	PHONE	
Line Input IMPEDANCE (Ohms)	560K	100K	100K	100K	100K	100K	100K	100K	100K	
Line Input SENSITIVITY (Volts)	0.06	0.06	0.06	0.06	0.06	0.07	0.07	0.07	0.07	
LINE OUTPUT IMPEDANCE (Ohms)	100K	10K	10K	100K	10K	100K	100K	100K	100K	
MAXIMUM REEL SIZE (Inches)	7	7	7	7	7	7	7	10½	10½	
POWER REQUIREMENTS	117 VAC. 30 W. 60 Hz.	117 VAC. 35 W. 60 Hz.	117 VAC. 45 W. 50/60Hz.	117 VAC. 80 W. 60 Hz.	117 VAC. 90 W. 50/60Hz.	117 VAC. 90 W. 60 Hz.	117 VAC. 90 W. 60 Hz.	117 VAC. 90 W. 60 Hz.	117 VAC. 110 W. 50/60Hz.	117 VAC. 110 W. 50/60Hz.
REWIND TIME 1200' TAPE (Sec.)	150	150	100	90	60	90	90	130***	130***	
BIAS FREQUENCY (kHz)	85	160	160	120	160	120	120	123	123	
CAPSTAN MOTOR TYPE	IND.	IND.	SERVO. CONTR.	HYST. SYNC.	SERVO. CONTR.	HYST. SYNC.	HYST. SYNC.	SERVO. CONTR.	SERVO. CONTR.	
REEL DRIVE MOTOR TYPE			TORQUE	TORQUE	TORQUE	TORQUE	TORQUE	TORQUE	TORQUE	
DIMENSIONS WxHxD (Inches)	15¼x 13½x 7½	15¾x 13¾x 7¾	16¾x 16¾x 8½	14½x 15½x 9½	17¾x 18¼x 8¾	16¾x 17¾x 9½	16¾x 17¾x 9½	17¼x 19¾x 10	17¼x 19¾x 10	
WEIGHT	17 LBS. 11 OZ.	16 LBS. 9 OZ.	27 LBS. 2 OZ.	33 LBS.	43 LBS.	46 LBS.	46 LBS.	57 LBS. 5 OZ.	57 LBS. 5 OZ.	
RECORDING SYSTEM	A	A	A	A	A	B	A	B	A	
PLAYBACK SYSTEM	A	A	A	A	A	B	A	A-B	A-B	
RETRACTOMATIC PINCH ROLLER	•	•								
SOUND-ON-SOUND	D	D	C	C	D	C	C	C	C	
VERTICAL-HORIZONTAL OPERATION	•	•	•	•	•	•	•	•	•	
NON-MAGNETIZING RECORD HEAD	•	•	•	•	•	•	•	•	•	
AUTOMATIC SHUT-OFF	•	•	E	E	E	E	E	E	E	
AUTOMATIC TAPE LIFTERS	•	•	•	•	•	F	F	F	F	
TAPE/SOURCE MONITORING		•	•	•	•	•	•	•	•	
THREE HEADS		•	I	•	I	•	•	G	G	
RECORD EQUALIZATION SELECTOR SWITCH		•	•	•	•	•	•	•	•	
MIC. & LINE MIXING		•	•	•	•	•	•	•	•	
NO PRESSURE PADS		•	•	•	•	•	•	•	•	
BUILT-IN ECHO		•	•	•	•	•	•	•	•	
BUILT-IN REEL LOCKS		•	•	•	•	•	•	•	•	
ELECTRICAL SPEED CHANGE		•	•	•	•	•	•	•	•	
PUSHBUTTON OPERATION		•	•	•	H	H	H	H	H	
THREE MOTOR DESIGN		•	•	•	•	•	•	•	•	
PLUG-IN HEAD BLOCK ASSEMBLY		•	•	•	•	•	•	•	•	
OPTIONAL FULL-FUNCTION REMOTE CONTROL		•	•	•	•	•	•	•	•	
FULLY ACCESSIBLE BIAS AND EQUALIZATION ADJUSTMENTS		•	•	•	•	•	•	•	•	

* ±2 dB with Sony SLH-180 Tape
 ** ±3 dB with Sony SLH-180 Tape
 *** 2400' Tape

- A — Quarter-Track Stereo
- B — Two-Track Stereo
- C — Built-in
- D — Requires optional patch cord and/or mixer
- E — Automatic Total-Mechanism Shutoff
- F — Defeatable
- G — Plus Second Playback Head
- H — Solenoid-Operated Transport with Feather-Touch Control Buttons
- I — Six-Head Function

All the above models have low-impedance microphone inputs with -72dB sensitivity. Phono plugs are used in both line inputs and outputs, the latter having a level of 0.775 volts. In addition, all models have an 8 ohm headphone monitor jack. Other features common to these units include digital tape counters, and record interlock.

SONY SUPERSCOPE®

You never heard it so good.

 **FIDELITY SOUND COMPANY**

Quadradiial Reel to Reel and Cartridge Machines

SONY® Model 854-4S

Professional-Quality Three-Motor

Quadradiial Tape Deck with 10½" REEL CAPACITY



Sony Model TC-854-4S

Professional-Quality Three-Motor Quadradiial Tape Deck

Want to add the ultimate in four-channel sound to your stereo system? Take a look at the exciting TC-854-4S!

Featuring complete four-channel fully-synchronized record and playback capabilities and VariSpeed pitch control, here is the finest Quadradiial recorder you can buy!

FEATURES:

- 10½" Reel Capacity
- Automatic Program Scanner
- ServoControl Motor
- Syncro-Trak for fully-synchronized recording
- Three Heads for Tape/Source Monitoring and wider Frequency Response
- Closed-Loop Dual Capstan Tape Drive System for lowest wow and flutter
- 15, 7½, and 3¾ ips Speeds
- Record Equalization Selector Switch for standard or Sony SLH-180 low-noise, high-output recording tape
- Plug-In Head Block Assembly
- Die-Cast Tape Guide and Head Block Mounting Frame
- Four-Digit Tape Counter
- Four Illuminated VU Meters, Calibrated to NAB Standards
- Sound-on-Sound Capability
- Two Stereo Headphone Monitor Jacks
- Fully Accessible Bias and Equalization Adjustments
- Logic-Controlled, Solenoid Operated Three-Motor Transport
- Price includes NAB Hub Adapters and Dust Cover

... and here's more about the TC-854-4S

Although designed primarily for sophisticated home and hobby recordings, the TC-854-4S has acquired a reputation for outstanding performance in a wide variety of professional applications. For example, some of the best-known record producers and engineers in the country specify the TC-854-4S for both rack-mount studio console installations and "live" remote recording at concerts and nightclubs. • Musical groups, instrumentalists, and singers use the TC-854-4S to record and analyze performance and rehearsal sessions. • Radio stations find it ideal for the automated playback of pre-recorded programming. • Even computer firms have found a place for the extreme reliability and stability of the TC-854-4S in complex data processing instrumentation!

Remember: if you won't accept less than concert hall realism, the TC-854-4S should be the nucleus of your audio system.



Sony Model TC-277-4

Quadradiial Tape Deck

If you're a budget-minded music lover, searching for realistic sound, take note: the new TC-277-4 is the lowest-priced quality four-channel reel-to-reel recorder on the market today. Besides having complete four-channel record and playback capability, which reproduces all of the vital dimensional aspects of music with full realism, the TC-277-4 is loaded with many other sophisticated features. All in all, a most impressive addition to any high-fidelity system... the Sony TC-277-4.

FEATURES:

- Complete Four-Channel Record and Playback
- Three Tape Speeds: 7½, 3¾ and 1½ ips
- Four-Channel/Two Channel Selector Switch
- Four Illuminated VU Meters
- Independent Four-Channel Level Controls
- Record Equalization Selector Switch for standard or Sony SLH-180 low-noise, high-output recording tape
- Tripla-Function Headphone Switch and Jack
- Retractable Pinch Roller
- Microphone and Auxiliary Inputs
- Automatic Tape Lifters
- Scrape Flutter Filter
- Pause Control with Lock
- Automatic Shut-Off
- Sound-with-Sound
- Sound-on-Sound Capability with Optional MX-8S Mixer
- Price includes empty 7" Reel, two RK-74 Patch Cords, and Head-Cleaning Ribbon



Sony Model TC-248D

Quadradiial Eight-Track Cartridge Playback Deck

Here's a low-cost way to bring all the excitement of true four-channel sound into your home! The new TC-248D plays both two-channel and four-channel eight-track cartridges for the ultimate in sound realism and convenience. You also get great features, including Automatic AC System Shut-Off, Three-Way Tape Eject System, and Illuminated Channel Indicator. Enclosed in a handsome walnut case, the TC-248D is built with traditional Sony quality for extra performance and rugged dependability.

FEATURES:

- Four-Channel/Two-Channel Eight-Track Playback
- Illuminated Channel Indicator
- Program Selector Switch
- Automatic and Manual Track Selector
- Auto AC System Shut-Off
- TMS (Automatic Total-Mechanism Shut-Off)
- Three-Way Tape Eject System
- Handsome Walnut Case

 FIDELITY SOUND COMPANY

Sony/Superscope Quadradiial Tape Decks

Models:	TC-277-4	TC-854-4S	TC-248D
FREQUENCY RESPONSE @ 15 ips. (Hz)		30-25K*	
FREQUENCY RESPONSE @ 7½ ips. (Hz)	30-20K	30-22K*	
FREQUENCY RESPONSE @ 3¾ ips. (Hz)	30-13K	40-15K*	30-13K
WOW AND FLUTTER @ 15 ips. (%)		.03	
WOW AND FLUTTER @ 7½ ips. (%)	0.12	.04	
WOW AND FLUTTER @ 3¾ ips. (%)	0.15	.08	0.17
WOW AND FLUTTER @ 1½ ips. (%)	0.2		
MAXIMUM REEL SIZE (Inches)	7	10½	8-TRACK CARTRIDGE
SIGNAL TO NOISE RATIO STANDARD TAPE (dB)	52	56	45
SIGNAL TO NOISE RATIO SONY SLH TAPE (dB)	55	59	
BIAS FREQUENCY (kHz)	120	120	
NUMBER OF MOTORS	1	3	1
CAPSTAN DRIVE MOTOR	INDUCT.	AC. SERVO CONTR.	INDUCT.
POWER REQUIREMENTS	120 VAC., 35 WATTS, 60 Hz.	117 VAC., 110 WATTS, 50/60 Hz.	120 VAC., 50 WATTS, 60 Hz.
MICROPHONE INPUT PLUG TYPE	MINI	PHONE	
OUTPUT IMPEDANCE (Ohms)	100K	100K	
DIMENSIONS WxHxD (Inches)	15 ¹¹ / ₁₆ x7 ¹¹ / ₁₆ x15 ¹¹ / ₁₆	17 ¹¹ / ₃₂ x22x9 ³¹ / ₃₂	13x5 ⁵ / ₃₂ x8 ¹¹ / ₃₂
WEIGHT	23 LBS., 2 OZ.	61 LBS., 7 OZ.	11 LBS., 3 OZ.
SYNCHRO-TRAK		•	
AUTOMATIC TAPE LIFTERS	•	A	
PAUSE CONTROL WITH LOCK	•	B	
MODULAR CONSTRUCTION		•	
ILLUMINATED COLOR-CODED FEATHER-TOUCH PUSH BUTTONS		•	
PLAYBACK LEVEL CONTROL		•	
BUILT-IN REEL LOCKS	•	•	
VERTICAL AND HORIZONTAL OPERATION		•	
SCRAPE FLUTTER FILTER	•	•	
ELECTRICAL SPEED CHANGE		•	
FULLY ACCESSIBLE BIAS AND EQUALIZATION ADJUSTMENTS		•	
PLUG-IN HEAD BLOCK ASSEMBLY		•	
FULL-FUNCTION REMOTE CONTROL CAPABILITY		•	

* ±2 dB with Sony SLH-180 Tape

A — Defeatable

B — Optional Remote Control incorporates a non-locking pause control

Quadradiial Model TC-248D includes: Four-Channel/Two-Channel Eight-Track Playback, Illuminated Channel Indicator, Program Selector Switch, Automatic and Manual Track Selector, Automatic AC System Shut-Off, TMS (Automatic Total-Mechanism Shut-Off), Three-Way Tape Eject System, and Walnut Case.

Quadradiial Model TC-854-4S has the following: Microphone and Auxiliary Inputs, Four-Digit Tape Counters, Automatic Total-Mechanism Shut-Off, Non-Magnetizing Record Heads, Microphone and Line Mixing, Tape/Source Monitoring, Record Interlock, Stereo Headphone Monitoring, Calibrated VU Meters, Record Equalization Selector Switch, and Low-Impedance Microphone Inputs.

Quadradiial Model TC-84 includes: Automatic Two-Channel/Four-Channel Switching, Four Individual Level Controls, Master Volume Control, Master Tone Control, Program Selector Switch, and Illuminated Channel Indicator.

SONY SUPERSCOPE

You never heard it so good.

 **FIDELITY SOUND COMPANY**

Model 330 - Combination Reel to Reel/Cassette Stereo Tape System/Control Center



SONY®

Model 330 Reel-to-Reel/Cassette Stereo Tape System/Control Center

Just add a tuner and record changer, and the Model 330 becomes the most flexible, complete stereo system available. You can record from microphone, phono, or auxiliary sources, direct to either cassette or reel-to-reel recorders, or transfer from one recorder to the other. A remarkable combination at an unbelievable low price

\$349.95

Plays or Records Standard Open Reels and Universal Cassettes
Can Dub from Reel to Cassette or Cassette to Reel
Reel Speeds of $7\frac{1}{2}$ ips, $3\frac{3}{4}$ ips, & $1\frac{1}{2}$ ips
Cassette Storage Compartment
Non-Magnetizing Record Head
Noise Suppressor Switch
Integrated Lid Speakers
Stereo Headphone Monitor Jack
Scrape Flutter Filter
Four Digit Tape Counter
Automatic Tape Lifter
Push Button Operation
End-of-Tape Indicator for Cassette

Reel Size: 7"

Frequency Response:

30 Hz to 18 K Hz at $7\frac{1}{2}$ ips
30 Hz - 13,000 K Hz at $3\frac{3}{4}$ ips
30 Hz - 7 K Hz at $1\frac{1}{8}$ ips
50 - 10 K Hz (CASSETTE)

Signal to Noise Ratio:

50 db (REEL RECORDER)
45 db (CASSETTE RECORDER)

Bias Frequency: 85 K Hz

Level Indication: VU Meter

Power Output: 15 watts

Wow and Flutter: .2% (CASSETTE)

.12% at $7\frac{1}{2}$ ips (REEL)
.15% at $3\frac{3}{4}$ ips (REEL)
.2% at $1\frac{1}{8}$ ips (REEL)

Dimensions: $21\frac{7}{16}$ " W X $11\frac{13}{16}$ " H X $13\frac{7}{8}$ " D

Weight: 43 pounds

 **FIDELITY SOUND COMPANY**

Sony/Superscope Condenser Microphones

Every model in the Sony/Superscope line of condenser microphones works on the same principles as the very finest and most expensive professional microphones. This is your assurance of crisp, clear, true-to-life sound pick-up.

So, if you're looking for excellent performance at a very comfortable price, check the microphones on the following pages. There's one just right for you.

ECM-16



**Sony Model ECM-16
Tie-Clasp/Lapel Condenser Microphone**

The ECM-16 is ideal for teachers, lecturers, clergymen and others who require an unobtrusive microphone for high-quality sound reinforcement or recording purposes. Comes complete with tie-clasp mount and battery.

ECM-18



**Sony Model ECM-18 Economy
Condenser Microphone**

Here is the world's lowest priced condenser microphone! The new, easy-to-afford ECM-18 brings professional quality sound pick-up to all home and hobby recording applications.

ECM-19B



**Sony Model ECM-19B
Cardioid Condenser Microphone**

Here's a fine condenser microphone, at an unbelievably low price. Perfect for recording voice and music, the ECM-19B is designed specifically for the recording hobbyist. Comes with desk stand and microphone holder.

ECM-21



**Sony Model ECM-21
Cardioid Condenser Microphone**

Exceptional performance characteristics make this THE mike for advanced recordists. Perfect for top quality home recording, the ECM-21 is also ideal for P.A. use, on a lecture, or in a discotheque. Comes with deluxe desk stand, microphone holder, and wind screen.

ECM-95S



**Sony Model ECM-95S
Cardioid Condenser Stop/Start
Microphone**

Add the extra convenience and performance of a remote condenser microphone with built-in stop/start switch to your portable Sony Cassette-Corder.® The ECM-95S is designed for any Sony recorder using stop/start microphone. (Please refer to accessory charts on back cover.)

ECM-99



**Sony Model ECM-99 One-Point
Stereo Condenser Microphone**

Actually two condenser microphones in one, the new ECM-99 lets you add the excitement of true stereo sound to your home and hobby recording with just one microphone unit. Finished in textured, brushed aluminum, the ECM-99 comes complete with swivel mount stand adapter, 20-foot twin-plug cable, and vinyl case.

F-98



**Sony Model F-98
Cardioid Dynamic Microphone**

This wide-range cardioid dynamic microphone, with its thin tapered design and unique removable stand, will complement any home recorder.

Sony
Cond

In addi
home a
the adv
fession

Used
other sc
and spe
fully sat

So, i
we invi
conden:
your So

EC



Sony
Cond

Desig
lapel
direct
cable
other
ness
requi
broad
forme
are c
packe
ultra-

C-

Son
Cor

Sony
Con
velo
regu
the
fame
of p
and
tech
disp
reco
148/

Sony/Superscope Professional Condenser Microphones

In addition to our line of fine condenser microphones for home and hobby recording, Sony/Superscope now offers the advanced recordist a superlative selection of truly professional condenser microphones.

Used by major recording studios, audio engineers, and other sound specialists from coast to coast, the performance and specifications of our professional series microphones fully satisfy even the most discriminating ears.

So, if you're seeking ultimate quality in your recordings, we invite you to look over the complete line of professional condenser microphones on the following pages. Then visit your Sony/Superscope dealer for a demonstration.



ECM-22P



Sony CRS-3N Elastic Shock-Mount Microphone Suspension

Sony Model ECM-22P Cardioid Condenser Microphone

Expressly designed for the serious recordist or performer, this exceptional condenser microphone is used regularly in professional recording studios from coast to coast. The ECM-22P is fast gaining a reputation for recordings which are hard to tell from the original performance! Comes with carrying case, stand adapter, and wind screen.

Effectively prevents vibrations in the floor and microphone stand from being transmitted to the microphone. Sturdy and attractive, the CRS-3N is supplied with sleeves to fit 3/4" and 1" diameter microphones.

ECM-50



Sony ECM-50 Tie-Tack/Lapel Condenser Microphone

Designed specifically as a tie-tack or lapel button microphone, the omnidirectional ECM-50 is particularly applicable for television interviewing and other uses where minimum obtrusiveness and maximum intelligibility are required. (Just watch any network news broadcast!) Battery power supply, transformer, and Cannon output connector are contained in a separate, miniature package, which is interconnected by an ultra-thin 10-foot cable.



ECM-51

Sony ECM-51 Telescopic Condenser Microphone

Ideal for on-the-spot recording of important events, the ECM-51 is a reporter's dream. With the condenser capsule placed atop a telescopic wand, the microphone is easily kept in close proximity to the person being interviewed. Used in conjunction with a tape recorder, the ECM-51 provides accurate recording of interviews and statements. Currently enjoying wide use on a variety of TV shows, the completely self-contained ECM-51 also incorporates a mute button for momentarily turning off the microphone.

ECM-53



Sony ECM-53 Cardioid Condenser Microphone

Mounted on a flexible gooseneck support for convenient attachment to studio console or podium, the ECM-53 is perfect for a variety of applications. Whether you're interested in recording, broadcasting, public address, or other similar uses, the ECM-53's exceptional sensitivity, wide frequency response and remarkable transient characteristics combine to reproduce the quality of sound demanded by today's exacting professionals.

C-37P



Sony C-37P Variable-Directivity Condenser Studio Microphone

Sony's new C-37P Variable-Directivity Condenser Studio Microphone was developed as a direct result of numerous requests from studio engineers around the world for an up-dated version of the famous Sony C-37A. The combination of proven excellence in sound quality, and the very latest in semiconductor technology makes the Sony C-37P indispensable in today's quality-oriented recording studio. (Requires Sony AC-148A Phantom Power Supply.)

C-500



Sony C-500 Studio-Standard Condenser Microphone

Undeniably the finest cardioid condenser microphone ever developed, the Sony C-500 is an essential part of the sophisticated studio's complement of microphones. It is the only microphone capable of equaling or surpassing the technical sophistication of all other equipment in today's state-of-the-art recording systems. (Requires Sony AC-148A Phantom Power Supply.)



Sony AC-148A DC Phantom Power Supply

The AC-148A is specifically designed to power Sony Condenser Microphone Models C-500, C-37P, and ECM-22P, but is equally suitable for use with other microphones with phantom power capability. In addition, dynamic and ribbon microphones may be connected to powered inputs with no degradation of audio quality. For the studio operator who also does remote recording, the Sony AC-148A provides unmatched versatility and economy. Handles up to ten additional microphones.

 **FIDELITY SOUND COMPANY**

Sony/Superscope Tape Recorder Accessories and Recording Tape

Sony/Superscope offers a complete line of top-quality accessories to increase the versatility of your Sony recorder, and to enhance the quality of your recordings.

And remember: whether you need open reels, cassettes, or eight-track cartridges, Sony recording tape offers the maximum in tape performance. In developing Sony's outstanding recording tapes — both standard and new high-performance types — our research chemists and engineers have religiously held to one fact: recordings are only as good as the quality of tape used.

In short, when you're Number 1 in tape recorders, you make the Number 1 tape.



Power Supplies

For increased recording flexibility, Sony power supplies convert battery-powered units to 117-volt AC operation.

- AC-12 AC Power Adapter for MX-12 Mixer
 - AC-148A 48-Volt Phantom Power Supply for ECM-22P Condenser Microphone (also for use with C-37P, C-500, and ECM-377)
 - AK-2 AC Power Supply/Battery Charger (AC-5BW) with Nickel-Cadmium Battery Pack (BP-22) for TC-40
- (AC-5BW and BP-22 available separately)



Battery Packs

Now you'll never have to worry about starting out the day with dead batteries; Sony rechargeable battery packs are automatically charged whenever external AC or DC power is used.

- BP-8 Nickel-Cadmium Rechargeable Battery Pack for CF-400, CF-550
- BP-9 Nickel-Cadmium Rechargeable Battery Pack for 110A
- BP-16 Nickel-Cadmium Rechargeable Battery Pack for TC-70, TC-90, TC-95, 120, 124CS, TC-95L, 126CS, CF-450 (not shown)
- BP-22 Nickel-Cadmium Rechargeable Battery Pack for TC-40

Auto Accessories



Car Stereo Speakers

The traditional Sony quality and performance of these speaker systems make any car stereo sound better. Designed for easy mounting and hook-up, each speaker system comes complete with phased wiring. Choose from three styles:

- SS-1
- SS-10
- SS-11



Car Mounting Brackets and Power Adapters

These Sony car mounting brackets lock your recorder firmly in place under the dashboard for in-car dictating and other uses. Sony power adapters provide direct operation from the cigarette lighter of any car or boat having a 12-volt battery.

- TB-1 Automobile Mounting Bracket for 110A
- TB-2 Automobile Mounting Bracket for 124 (not shown)
- DCC-2AW Automobile Cigarette Lighter Adapter for 770, 800-B
- DCC-126 Automobile Cigarette Lighter Adapter for Cassette-Corders

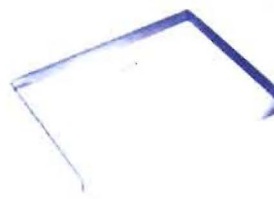

Dust Covers

Protect your Sony tape deck and enhance its appearance with one of these deluxe dust covers.

- DP-2 Molded Plastic Dust Cover for 252-D, 352-D
- DP-5 Molded Plastic Dust Cover for 440
- DP-7 Molded Plastic Dust Cover for 160, 165 (shown above)
- DP-77 Machine-Formed Plexiglass Dust Cover for 770



Carrying Cases

Deluxe Sony carrying cases protect your recorder and provide convenient storage compartments for microphones and other accessories.

- LC-1 Vinyl Tote Bag for 110A
- LC-8B Carrying Case for 800-B



Sony BE-7 Cassette Insta-Erase

Simply insert a cassette into the Insta-Erase and say good-bye to yesterday's dictation and recordings! Works automatically without AC or battery power. Attractively styled in walnut veneer and brushed aluminum.

Remote

These Sony remote controls are an important part of your Sony tape recorder system.

FS-6

RM-6

RM-16

RM-15

Sony BE-7 Micro

Designed in audio new HSE dynamic full-range quality, also perfect for applications adaptor.



Remote Controls

These Sony remote control units add an important convenience to your Sony tape recorder.

FS-6 Foot Switch

Adapts any Sony recorder using stop/start microphone, for use in transcribing dictation. Foot-operated start/stop control leaves hands free. (Please refer to accessory charts on back cover.)

RM-6 Remote VariSpeed Control

For Model 800-B. Allows variation of playback speed by $\pm 10\%$, to match the pitch of a sound on tape with that of a "live" musical instrument.

RM-16 Full-Function Remote Control

Provides remote operation of all major functions of 650 and 850 series, including Record, Playback, Fast-Forward, Rewind, and Instant Stop.

RM-15 Remote Control Stop/Start Switch

For any Sony tape recorder, cassette or reel-to-reel, that operates with remote stop/start microphone.



Sony HS-23A Learning Lab Microphone-Headset

Designed for use with the TC-95L in audio educational applications, the new HS-23A combines a built-in dynamic microphone with a set of full-range headphones. This top-quality, low-impedance headset is also perfect for a variety of other applications — just add the plug adaptor of your choice.



Empty Tape Reels

These sturdy, warp-resistant reels are made of extra-heavy gauge plastic. Distinctive, computer-styled design adds a professional look to any tape recorder. For convenient storage, each reel comes in a rugged box.

MTRB-3 (3" dia.)

MTRB-5 (5" dia.)

MTRB-7 (7" dia.)

MTRB-11 (10½" dia. aluminum with NAB hub)



Headphones

Now you can enjoy your own personal stereo performances without disturbing others around you! These Sony headphones offer unmatched performance, comfort and value.

DR-6A Stereo Headphone

Here's the top of the line! This comfortable, high-quality, dynamic stereo headphone provides full-range frequency response for private listening or monitoring. 8 ohm impedance.

DR-7A Stereo Headphone

For an amazingly low price, the economical DR-7A offers smooth, wide-range frequency response, luxurious foam-cushioned earpieces, comfortable leatherette headband, and an extendable coiled audio cable. 8 ohm impedance.

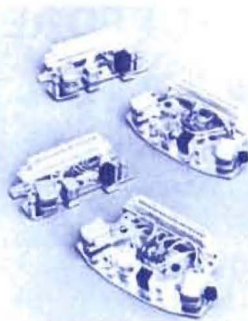

Head Assemblies

For Sony recorders with plug-in head assemblies. Convert your two-track stereo recorder for quarter-track operation, or vice-versa. Changing head assemblies takes less than a minute!

H-17-2S Two-Track Plug-In Head Block Assembly for 650-4

H-17-4S Quarter-Track Plug-In Head Block Assembly for 650-2

H-60-21S Two-Track Plug-In Head Block Assembly for 850-4

H-60-41S Quarter-Track Plug-In Head Block Assembly for 850-2



Recorder Maintenance Accessories

It's easy to keep your tape recorder performing "like new" with these Sony maintenance accessories. Periodic head demagnetizing and cleaning take only minutes, yet are **absolutely necessary** for continued top performance.

HE-2 Head Demagnetizer

Specially designed to provide maximum reduction of residual magnetism on recording heads. Features pushbutton on/off switch for ease of operation.

CLH-1 Head Cleaning Pen

A few quick strokes of this pen is all that it takes to remove tape oxide and dirt build-up from heads.



Sony CRS-3N Elastic Shock-Mount Microphone Suspension

Effectively prevents vibrations in the floor and microphone stand from being transmitted to the microphone. Sturdy and attractive, the CRS-3N is supplied with sleeves to fit ¾" and 1" diameter microphones.

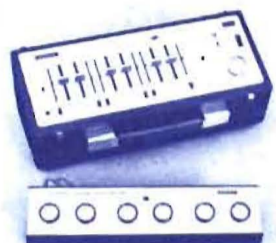

Mixers

Achieve professional-sounding recordings every time by using multiple microphones and a Sony audio mixer. Also perfect for use with public address systems, these mixers can handle as many as six microphones (or lines) simultaneously.

MX-6S Stereo/Mono Mixer

This versatile accessory readily connects to most Sony/Superscope recorders. Required for sound-on-sound recording with the 252-D, 352-D, and 277-4.

MX-12 Active Six-Channel Stereo/Mono Mixer

Here's a feature-packed mixer for use with tape recorders, P.A. and high-fidelity amplifiers. Great for musical groups!

- Mixes any combination of up to six microphones/lines, stereo or mono.

- Straight-Line Graphic Controls

- Dual Level Meters

- Input Attenuator Switches select proper input sensitivity

- High/Low-Level Stereo Outputs

- Center-Channel Stereo Mixing

- Battery-Powered for maximum convenience

- AC Operation with optional AC-12 adapter

FIDELITAPE FOOT PEDAL START/STOP/BACKSPACE

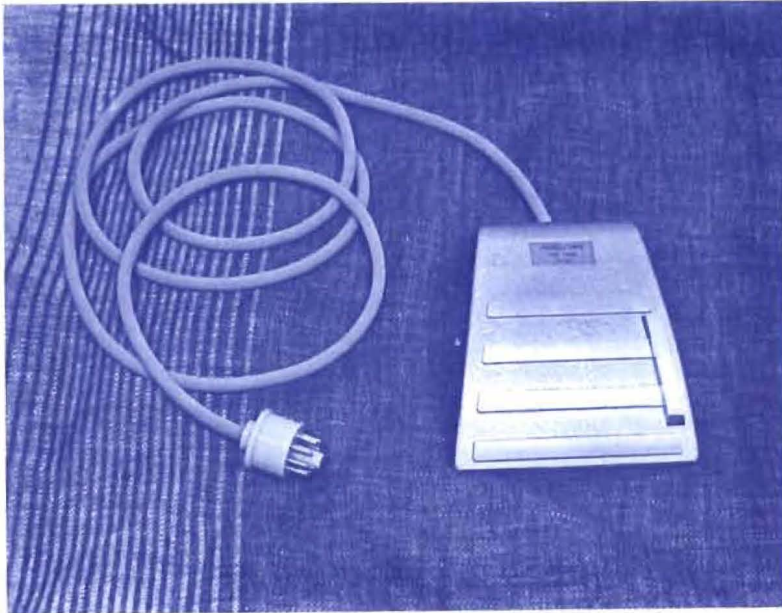

USEABLE WITH

****SONY MODEL 580**



****SEE PAGE 17**

***BRAUN MODEL TG-1000**



***SEE NEXT PAGE**

PERF

Frequ
(acc. 1
20-25,
20-15,
20- 8,
Signal
(DIN 4
60 db
60 db
57 db
Distor
VU- m
0.6%
0.7%
0.8%
Wow &
(DIN 4
<0.05
<0.09
<0.25
Rewin

FEATU

3 mot
motor
3 spee
2 trac
3 or 4
(chev
versio
Electr
both r

BRAUN TG 1000 STEREO TAPE DECK

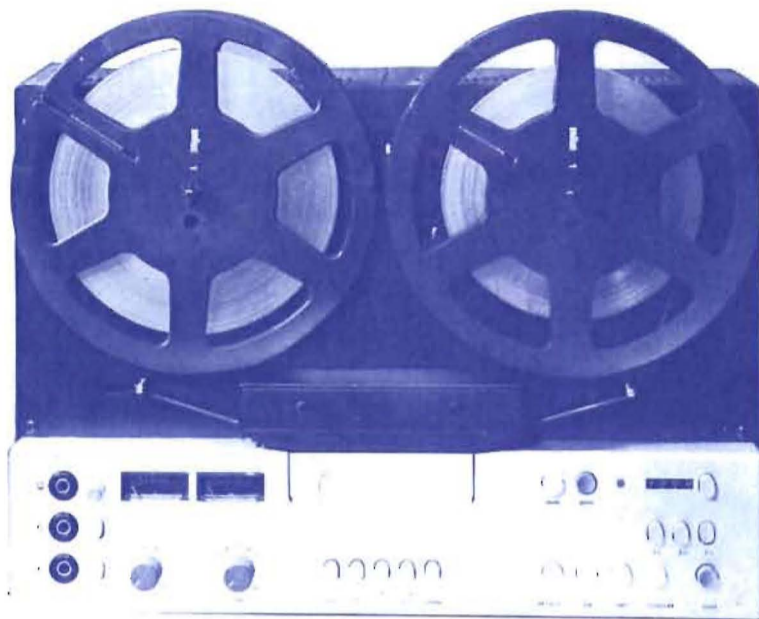

The TG 1000 operates in any position, it has a space for a fourth head in its plug-in head assembly. The additional head can be used as 4-track play back head, as 4-channel play back head or be used for slide synchronizing. There is a remote control unit TGF3 available for all functions. — All US-plugs. All headphones with impedances from 5-2000 ohms can be driven to full volume. Sound on sound; echo; tape monitoring are provided. The counter has 4 digits, and the unique new TB 1022 low noise, high output tape eliminates the need for 10.5" reels: The TG 1000 holds 3300ft. of tape on its 8 $\frac{3}{4}$ " reels. The tape drive with the electronic tension control is so gentle and foolproof that even triple play tape may be used. The built in cable driver and the wide dynamic range input circuitry permit flexibility at the interfaces to amplifiers and microphones. The level meters are peak reading for fast response. The robust construction is very compact and fully modular. All circuitry is silicon solid state.

PERFORMANCE:

Frequency response: (minimum)
(acc. to DIN 45511)
20-25,000 Hz @ 7 $\frac{1}{2}$ ips \pm 2.5 db
20-15,000 Hz @ 3 $\frac{3}{4}$ ips \pm 2.5 db
20- 8,000 Hz @ 1 $\frac{7}{8}$ ips \pm 2.5 db
Signal to noise ratio
(DIN 45505/2.1) : (two track)
60 db @ 7 $\frac{1}{2}$
60 db @ 3 $\frac{3}{4}$
57 db @ 1 $\frac{7}{8}$
Distortion at "0" db (DIN 45405)
VU- meter reading:
0.6% @ 7 $\frac{1}{2}$
0.7% @ 3 $\frac{3}{4}$
0.8% @ 1 $\frac{7}{8}$
Wow and flutter:
(DIN 45507).
<0.05% @ 7 $\frac{1}{2}$
<0.09% @ 3 $\frac{3}{4}$
<0.25% @ 1 $\frac{7}{8}$
Rewind time: 90 sec for 3300 ft

FEATURES:

3 motors (one brushless dc-servo motor, 2 ac-servo motors)
3 speeds (7 $\frac{1}{2}$; 3 $\frac{3}{4}$; 1 $\frac{7}{8}$)
2 track or 4 track
3 or 4 professional heads (chevron-technique in 2 track version)
Electronic tape tension control on both reels

Electro-mechanical brakes for fast smooth action
Pre-adjusted plug-in head assembly
Modular construction and all silicon circuitry
All functions relay controlled and solenoid actuated
Remote control unit for all functions (optional)
Prepared for 4-channel playback (optional)
Noisefree "pause" button for tape editing
Built-in tape splicer, 4 (2) input mixer, 4-digit counter
Feather-touch pushbuttons, fully fool proof
Multiplay and "off the tape" monitoring
Built in cable driver (1 volt, 600 ohms)
Slide synchronizer (optional) and adjustable head phone output
Ultra-compact robust construction (17.7" x 12.6" x 5.3", 44 lbs)
Drive and brake system allows use of triple play tape
Operation in any position

PRICE: \$749.00*

DIN is the tight conservative German rating system, by US-standard specs would improve.

*FIDELITAPE FOOTPEDAL

START / STOP / BACKSPACE



See page 26

 **FIDELITY SOUND COMPANY**

doro 702. dictating-transcribing system.

Finest type of compact cassette office communications system made.

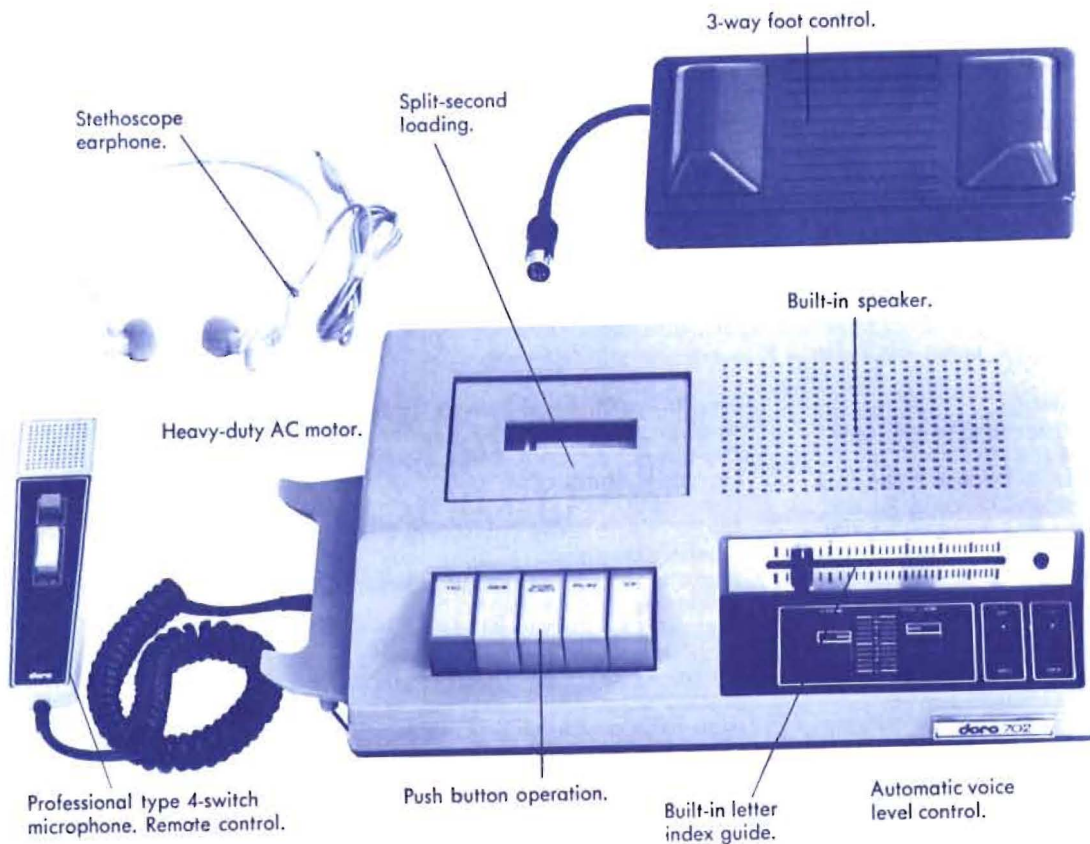

Doro 702 dictating unit comes with microphone and bracket, telephone pick-up, log pad, C60 compact cassette, dust cover.

Doro 702 transcribing unit comes with foot pedal, stethoscope and loop earphones, C60 compact cassette, dust cover.

Accessories are available which convert either unit to a complete, all-purpose dictating-transcribing unit.

Ask your Dorp dealer for price list and full details.

doro 311. automatic telephone answering system.

A top-quality, fully warranted unit at an incredibly low price.

Fully warranted.

Automatic voice level control.

Built-in speaker.

Automatic shut-off.

Endless loop cassette.

Electronic message counter.

Standard compact cassette.



Fingertip push button controls.

Built-in earphone attachment.

Monitor switch.

Dynamic remote control microphone.

Doro 311 comes complete with microphone, 20-second endless loop compact cassette, C60 compact cassette.

Also available, endless loop cassettes for various applications in the following time lengths: 30-seconds, one minute, three minutes, six minutes and 12 minutes.

Ask your Doro dealer for price list and full details.

 **FIDELITY SOUND COMPANY**

PROFESSIONAL

Mincom Division **3M** COMPANY

RECORDERS



MODEL PAR 410 M-64
1/4 Inch 2 Track Recorder/Reproducer

SIGNAL-TO-NOISE RATIO:

	Standby	Biased Tape
Normal	65 dB	62 dB

70 mil track width 20 Hz - 20 kHz bandwidth, with reference to 3% maximum third harmonic distortion level at 700 Hz, using tape specified below.

FREQUENCY RESPONSE:

7.5 ips reproduce	±2 dB 30 Hz - 12 kHz
7.5 ips record/reproduce	±2 dB 30 Hz - 12 kHz
15 ips reproduce	±2 dB 30 Hz - 15 kHz
15 ips record/reproduce	±2 dB 30 Hz - 15 kHz

FLUTTER:

Speed (ips)	Flutter Band (Hz)	Maximum Flutter (rms)
30	0.5 to 200	0.05%
	0.5 to 5000	0.08%
15	0.5 to 200	0.06%
	0.5 to 5000	0.08%
7-1/2	0.5 to 200	0.10%
	0.5 to 5000	0.15%

NOTE: All measurements of flutter made by recording a tone on machine under test, rewinding and measuring flutter on replay. Flutter measurement is maximum cumulative unweighted.

Phasing: On all channels signal input to output polarity is maintained. 1 mil wavelength phase error less than 90° between any two tracks.

Channel separation: Channel to channel crosstalk separation is greater than 50 dB at 500 cycles (zero VU).

Phase correction: Playback amplifier includes phase rotation circuit to optimize square wave and transient response for each speed.

Bias and erase oscillator. Master oscillator on tape transport supplies 120 kHz low impedance bus feeding individual bias and erase power amplifiers for each channel.

Speed: 7-1/2 and 15 ips standard 15 and 30 ips available.

Timing accuracy: ±0.1%

Start time: Less than 1.0 seconds to reach sync speed.

Stop time: 1.0 second from play or record mode.

Rewind time: 1.7 minutes for 2,400 feet.

Transport controls: Operating controls located on lower edge of transport.

SIZE AND WEIGHT:
Height: 53-3/4 inches.
Width: 27 inches.
Depth: 22-1/2 inches.
Weight: Approximately 250 pounds

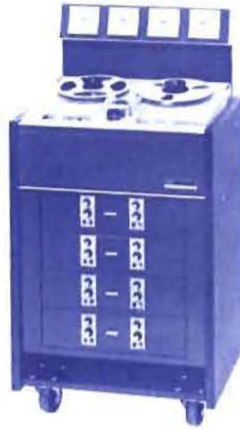

MODEL PAR 410 M-64
1/2 Inch 4 Track Recorder/Reproducer

SIGNAL-TO-NOISE RATIO:

	Standby	Biased Tape
Normal	65 dB	62 dB

70 mil track width 20 Hz - 20 kHz bandwidth, with reference to 3% maximum third harmonic distortion level at 700 Hz, using tape specified below.

FREQUENCY RESPONSE:

7.5 ips reproduce	±2 dB 30 Hz - 12 kHz
7.5 ips record/reproduce	±2 dB 30 Hz - 12 kHz
15 ips reproduce	±2 dB 30 Hz - 15 kHz
15 ips record/reproduce	±2 dB 30 Hz - 15 kHz

FLUTTER:

Speed (ips)	Flutter Band (Hz)	Maximum Flutter (rms)
30	0.5 to 200	0.05%
	0.5 to 5000	0.08%
15	0.5 to 200	0.06%
	0.5 to 5000	0.08%
7-1/2	0.5 to 200	0.10%
	0.5 to 5000	0.15%

NOTE: All measurements of flutter made by recording a tone on machine under test, rewinding and measuring flutter on replay. Flutter measurement is maximum cumulative unweighted.

Phasing: On all channels signal input to output polarity is maintained. 1 mil wavelength phase error less than 90° between any two tracks.

Channel separation: Channel to channel crosstalk separation is greater than 50 dB at 500 cycles (zero VU).

Phase correction: Playback amplifier includes phase rotation circuit to optimize square wave and transient response for each speed.

Bias and erase oscillator. Master oscillator on tape transport supplies 120 kHz low impedance bus feeding individual bias and erase power amplifiers for each channel.

Speed: 7-1/2 and 15 ips standard 15 and 30 ips available.

Timing accuracy: ±0.1%

Start time: Less than 1.0 seconds to reach sync speed.

Stop time: 1.0 second from play or record mode.

Rewind time: 1.7 minutes for 2,400 feet.

Transport controls: Operating controls located on lower edge of transport.

SIZE AND WEIGHT:
Height: 53-3/4 inches.
Width: 27 inches.
Depth: 22-1/2 inches.
Weight: Approximately 250 pounds.



MODEL PAR 510 M-56
1 Inch 8 Track Recorder/Reproducer (Nonconvertible)

SIGNAL-TO-NOISE RATIO:

	Standby	Biased Tape
Normal	67 dB	62 dB
Sync	60 dB	60 dB

70 mil track width 20 Hz - 20 kHz bandwidth, with reference to 1% maximum third harmonic distortion level at 700 Hz, using tape specified below.

FREQUENCY RESPONSE:

7.5 ips reproduce	±2 dB 30 Hz - 12 kHz
7.5 ips record/reproduce	±2 dB 30 Hz - 12 kHz
15 ips reproduce	+1, -2 dB 30 Hz - 15 kHz
15 ips record/reproduce	+1, -2 dB 30 Hz - 15 kHz

FLUTTER:

Speed (ips)	Flutter Band (Hz)	Maximum Flutter (rms)
30	0.5 to 200	0.05%
	0.5 to 5000	0.08%
15	0.5 to 200	0.06%
	0.5 to 5000	0.08%
7-1/2	0.5 to 200	0.09%
	0.5 to 5000	0.13%

SYNC RESP. +1, -4 dB 50 Hz - 15 kHz

FLUTTER:

Speed (ips)	Flutter Band (Hz)	Maximum Flutter (rms)
30	0.5 to 200	0.05%
	0.5 to 5000	0.08%
15	0.5 to 200	0.06%
	0.5 to 5000	0.08%
7-1/2	0.5 to 200	0.09%
	0.5 to 5000	0.13%

NOTE: All measurements of flutter made by recording a tone on machine under test, rewinding and measuring flutter on replay. Flutter measurement is maximum cumulative unweighted.

Phasing: On all channels signal input to output polarity is maintained. 1 mil wavelength phase error less than 90° between any two tracks.

Channel separation: Channel to channel crosstalk separation is greater than 50 dB at 500 cycles (zero VU).

Phase correction: Playback amplifier includes phase rotation circuit to optimize square wave and transient response for each speed.

Bias and erase oscillator. Master oscillator on tape transport supplies 120 kHz low impedance bus feeding individual bias and erase power amplifiers for each channel.

Speed: 7-1/2 and 15 ips standard 15 and 30 ips available.

Timing accuracy: ±0.1%

Start time: Less than 1.0 seconds to reach sync speed.

Stop time: 1.0 second from play or record mode.

Rewind time: 1.7 minutes for 2,400 feet.

Transport controls: Operating controls located on lower edge of transport.

Remote control: Permits full operation of the transport from two locations.

SIZE AND WEIGHT:
Height: 53-3/4 inches plus 7 inches when remote control is mounted on meter panel.
Width: 27 inches.
Depth: 22-1/2 inches.
Weight: Approximately 300 pounds.

MODEL
2 Inch 1

SIGNAL

Normal

Sync

70 mil track width, v

third harmonic distortion

using tape specified below.

FREQUENCY

7.5 ips reproduce

7.5 ips record/reproduce

15 ips reproduce

15 ips record/reproduce

15 ips record/reproduce

SYNC RESPONSE

FLUTTER:

Speed (ips)

30

15

7-1/2

NOTE:

by recording a tone on machine under test, rewinding and measuring flutter on replay. Flutter measurement is maximum cumulative unweighted.

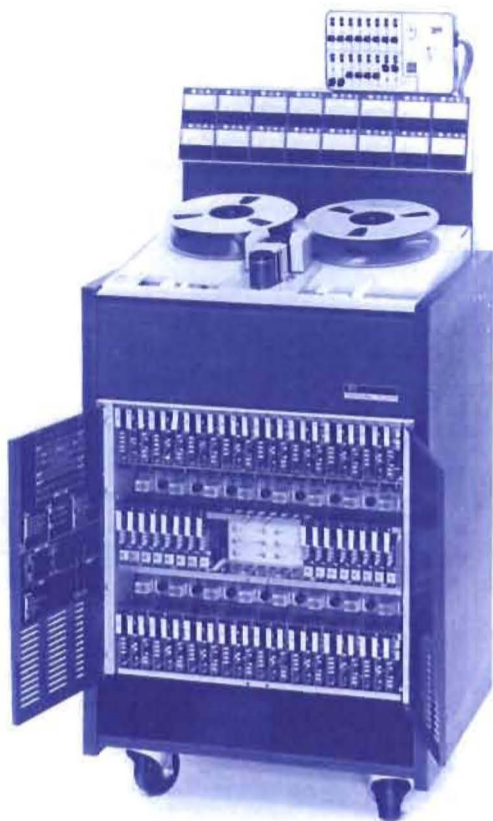

MODEL PAR 810 M-56

2 Inch 16 Track Recorder/Reproducer

SIGNAL-TO-NOISE RATIO:

	Standby	Biased Tape
Normal	67 dB	62 dB
Sync	60 dB	60 dB

70 mil track width 20 Hz - 20 kHz bandwidth, with reference to 1% maximum third harmonic distortion level at 700 Hz, using tape specified below.

FREQUENCY RESPONSE:

7.5 ips reproduce	±2 dB 30 Hz - 12 kHz
7.5 ips record/ reproduce	±2 dB 30 Hz - 12 kHz
15 ips reproduce	+1, -2 dB 30 Hz - 15 kHz
15 ips record/ reproduce	+1, -2 dB 30 Hz - 15 kHz

SYNC RESP. +1, -4 dB 50 Hz - 15 kHz

FLUTTER:

Speed (ips)	Flutter Band (Hz)	Maximum Flutter (rma)
30	0.5 to 200	0.05%
	0.5 to 5000	0.08%
15	0.5 to 200	0.06%
	0.5 to 5000	0.08%
7-1/2	0.5 to 200	0.09%
	0.5 to 5000	0.13%

NOTE: All measurements of flutter made by recording a tone on machine under test, rewinding and measuring flutter on

replay. Flutter measurement is maximum cumulative unweighted.

Phasing: On all channels signal input to output polarity is maintained. 1 mil wavelength phase error less than 90° between any two tracks.

Channel separation: Channel to channel crosstalk separation is greater than 50 dB at 500 cycles (zero VU).

Phase correction: Playback amplifier includes phase rotation circuit to optimize square wave and transient response for each speed.

Bias and erase oscillator. Master oscillator on tape transport supplies 120 kHz low impedance bus feeding individual bias and erase power amplifiers for each channel.

Speed: 7-1/2 and 15 ips standard. Other speeds available on special order.

Timing accuracy: ±0.1%.

Start time: Less than 1.0 seconds to reach sync speed.

Stop time: 1.0 second from play or record mode.

Rewind time: 1.7 minutes for 2,400 feet.

Transport controls: Operating controls located on lower edge of transport.

Remote control: Permits full operation of the transport from two locations.

SIZE AND WEIGHT:

Height: 53-3/4 inches plus 7 inches when remote control is mounted on meter panel.

Width: 27 inches.

Depth: 22-1/2 inches.

Weight: Approximately 304 pounds (16 track).

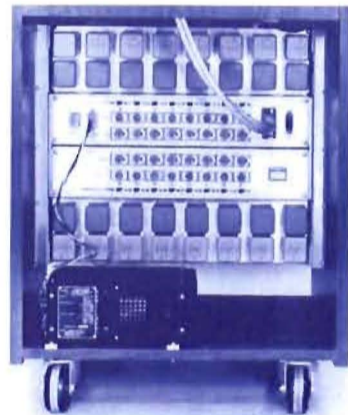
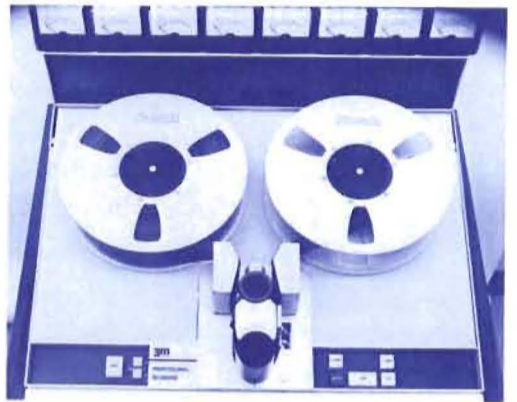
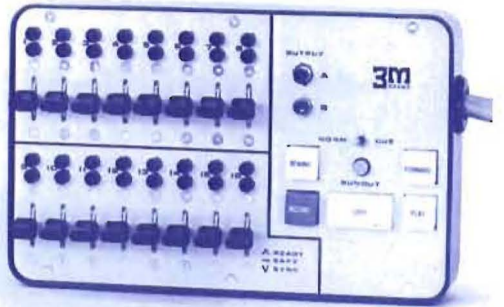

FIDELITY SOUND COMPANY

SOUND SCRIBER
MONITOR
Model S-124T, Magnetic Tape
RECORDER/REPRODUCER

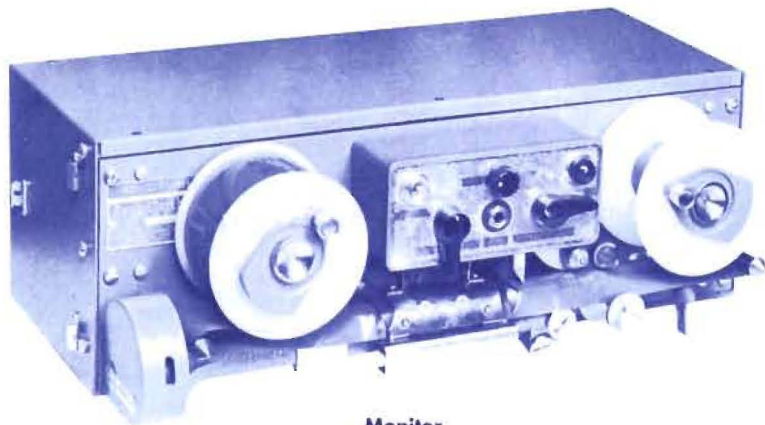

Monitor

The Monitor Recorder/Reproducer is a single-channel magnetic tape recorder designed for documenting, logging, or monitoring voice communications over extended periods of time. It records continuously, unattended and without tape changes for 24 hours. Tape is precision preprinted with time marks every minute, providing pin-point accuracy in place finding, and making external time reference devices unnecessary.

Your practical, low cost solution to long-time recording needs.

24 HOURS OF UNATTENDED RECORDING:

A "Monitor" exclusive... 24 hours of reliable, nonstop recording. Simply snap it on, and SoundScriber does the rest... eliminates frequent and distracting tape changes... gives 24 hours of uninterrupted recording.

"SNAIL-PACE" TAPE SPEED:

Tape travels only 2½ inches per minute permitting 24 hours of recording on a single 300 foot reel.

TROUBLE FREE OPERATION:

Slow operating speed imposes less wear on moving parts thus holding maintenance expense to a minimum. "Monitor" is completely gear-driven... operating efficiency is enhanced through elimination of short-lived belts.

"SWISS-WATCH" TIMING:

Easily readable calibrations in minutes are printed right on the recording tape. No difficulty spotting the exact time a message was recorded... precision engineering provides accuracy of 1/10% or better.

HIGH QUALITY VOICE RECORDING:

Frequency response of between 200 and 3500 cps assures quality recording within the voice range.

15 SECOND TAPE ERASING:

Special tape demagnetizer bulk-erases recorded tape reels quickly, easily. *It is not possible to accidentally erase tape while on the "Monitor" unit.*

EASY OPERATION:

A minimum of easily-accessible controls simplify operation. "Record-Off-Playback" are controlled by a single lever.

TAMPER-PROOF TAPE:

Because of SoundScriber's special transverse recording pattern, it is practically impossible to alter or tamper with recordings.

FAST MANUAL REWIND:

Tapes are easily scanned for location of certain recorded segments... entire tape can be rewound from end to beginning in less than two minutes.

VOICE-ACTUATED MODE

Optional module with "Manual-Automatic" switch can be in-built... provides a trustworthy means of conserving tape. The spoken word starts the recording process which terminates with the termination of the recordable sound. All units are equipped to receive this additional "plug in" module.

SOUNDSCRIBER

REPORTER

Model S-116-CT, Magnetic Tape

RECORDER/REPRODUCER
with Transcription Facilities



Listening Device



Foot Control



Reporter

Similar to the Monitor, but with extended fidelity and transcription features added, the Reporter is widely used for recording court proceedings and in other applications where ease of transcription is important. It is available in both 16-hour and 24-hour models.

The new SoundScriber Model S-116-CT "Reporter" Tape Recorder/Reproducer is the perfect answer to applications requiring transcription facilities in addition to long-time recording capabilities.

The Model S-116-CT is built to the same exacting specifications as the famous SoundScriber Model S-124T "Monitor" with the following additional features:

1. Automatic push button forward-reverse tape scan.
2. Instant-start-stop tape movement with back space feature controlled by accessory foot pedal.

With this recorder, a recording can be transcribed in whole or part by any typist familiar with the use of standard office dictating machines.

The host of recording applications for which this recorder is well suited includes:

Court proceedings	Boards of Appeal
Conferences	Finance Boards
Labor Management Meetings	Committee Hearings
Sales Meetings	Town Council Meetings
Conventions	Board of Education Meetings
Zoning & Planning Commission Meetings	Boards of Taxation & Finance

The S-116-CT can also be used for long time communications monitoring when there is no necessity to transcribe the recordings.

 **FIDELITY SOUND COMPANY**



Professional Broadcast, P.A. and Recording Microphones

Cardioid Dynamic

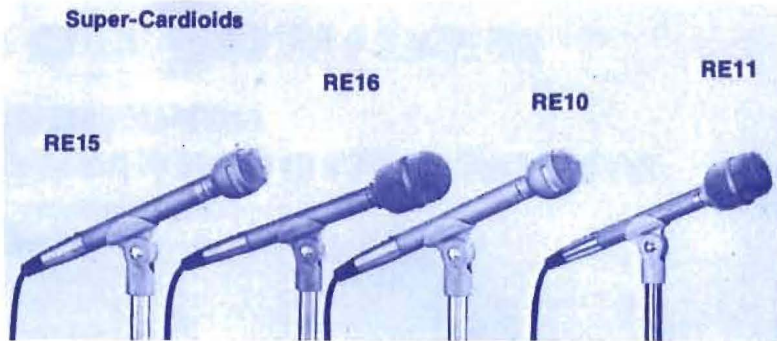

RE15: Highest quality professional super cardioid "Continuously Variable-D"* (maximum off-axis rejection at 150° from front).† Most uniform polar pattern at all frequencies ever offered in a cardioid microphone. Integral bass compensation switch. Cable and mounting clamp furnished. Response: 80 to 15,000 Hz. Impedance: Lo-Z. Output level: -56 dB. Finish: Fawn beige Micomatte. \$169.80

APPLICATIONS: On stand, hand-held, or portable boom use/Fishpoled for dialogue in motion picture recording/Individual instrument (or section) pickup for orchestral recording/In professional public address controls effects of resonance and reverberation.

RE16: Similar to RE15 except has integral blast and pop filter around head. For close-up vocal use on stand or hand-held. Virtually eliminates pickup of breath noises. Strong metal screen prevents damage. Specs same as RE15. \$176.70

RE10: Similar in design and construction to RE15, but for applications with slightly less rigid performance tolerances. Response: 80 to 13,000 Hz. Impedance: Lo-Z. Output: -55 dB. \$99.60

RE11: Similar to RE10 except with integral blast and pop filter around head. Virtually eliminates breath noises when used for close-up vocals. Strong metal protective screen around filter. Same specifications as RE10. \$106.50

†U.S. Patent No. 3,115,207



Electro-voice



Professional Microphones

Omnidirectional Dynamic

635A: Most popular professional quality performer's microphone. Smooth, carefully shaped response yields "flat effect" when used close up. Built-in four-stage pop and breath blast filter. Cable and mounting clamp furnished. Response: 80 to 13,000 Hz. Lo-Z. Output level: -55 dB. Finish: Fawn beige Micomatte. \$56.70

APPLICATIONS: Stage performance/Wide dynamic range, freedom from proximity effect, assures consistent results regardless of working distance/No windscreen necessary.

RE50: Noiseless Hand & Stand-For vocals, interviewing, instrumental broadcast, and recording. Extremely low susceptibility to mechanical shock, handling and cord noise, or breath pops due to unique double case design separated by rubber isolation mounting. Non-reflecting fawn beige Micomatte finish. Same ruggedness and electrical characteristics of the 635A. Cable and mounting clamp furnished. Response: 80 to 13,000 Hz. Output: -55 dB. Impedance: Lo-Z. \$77.10

RE55: Smooth, peak free wide-range response combined with functional styling makes this the most versatile professional quality omnidirectional dynamic ever offered. Cable and mounting clamp furnished. Response: 40 to 20,000 Hz. Lo-Z. Output level: -55 dB. Finish: Fawn beige Micomatte. \$141.30

APPLICATIONS: Recording symphony orchestra/Close instrument miking/Hand held for audience participation and interview use/On-the-spot news coverage.

654A: Slim-trim broadcast dynamic, can be used stand mounted, hand held, or as lavalier. Matches all low impedance inputs. Cable and mounting clamp furnished. Frequency response: 50 to 15,000 Hz. Output level: -57 dB. Non-reflecting gray finish. \$67.50



FIDELITY SOUND COMPANY



The 5 way address microphone. These sound enough microphone (and

Type: Frequency Micro microphone XLR-3 (Uses not low impedance microphone Auxil a top Contr to ra micro The / recor



A c amp reinf impe celle as a tion and VTR sign. The VU and phor othe bath

MODELS M68 • M68FC



The Shure Microphone Mixers are a practical, efficient and economical way of increasing the efficiency, usefulness and flexibility of public-address and paging systems, or tape recorders using more than one microphone or other sound source. One prime example: extra microphones can be placed in the audience for question and answer sessions. These new mixers are unique in that they satisfy the needs of most sound systems and serious tape recording enthusiasts, while being light enough to be portable, simple to operate and modest in cost. Each microphone (or other sound source) can be cut in or out of the system (and independently balanced for volume) without loss in microphone

output level. In addition to independent volume controls, a master volume control simultaneously controls the gain of all inputs. The M68 can therefore be used as a conveniently "at-hand" sound system volume control in situations where the regular amplifier is located some distance away.

Model M68 Mixer. Input connections are MALE Cannon XLR-3-14 type. (Uses XLR-3-11C type Mate.) **List Price: \$125.00**

Model M68FC Mixer. Input connections are FEMALE Cannon XLR-3-13 type. (Uses XLR-3-12C type Mate.) **List Price: \$135.00**

Type: Transistorized.

Frequency Response: 30 to 20,000 Hz.

Microphone Inputs: The back of the M68 mixer has four Cannon type microphone inputs. Model M68 has MALE Cannon XLR-3-14 type (Uses XLR-3-11C type Mate). Model M68FC has FEMALE Cannon XLR-3-13 type (Uses XLR-3-12C type Mate). Each accepts a Dynamic or Ribbon microphone (not recommended for crystal or ceramic microphones), either high or low impedance (balanced or unbalanced); input impedance for each microphone is selected by a slide switch. You can use one type or model microphone, or mix several types and impedances.

Auxiliary Input. A fifth input labeled "AUX" is high level and accepts a tape recorder, phonograph or tuner signal.

Controls: Four individual Microphone Volume Controls make it possible to raise or lower the level of sound from each microphone or to cut microphones in and out at will.

The Auxiliary Input Volume Control controls the sound level of the tape recorder, phonograph, or tuner.

SPECIFICATIONS

The Master Volume Control simultaneously adjusts the volume of all five input sources.

The On-Off Switch. This control not only controls the AC power, but when using the A68B battery power supply, the DC power supply switches the battery on and off to increase battery life when not in use.

Outputs: The M68 can be used to connect up to four microphones and a tape recorder, or tuner, or phonograph to any amplifier or tape recorder with a single connection. It has two outputs: one provides high or low impedance output for connection to the microphone input of a sound system amplifier or tape recorder. Desired impedance is selected by switch. The other provides a high impedance, high level output designed primarily to feed a power amplifier or tape recorder requiring .5 to 2 volts.

Because of the flexibility of outputs, the M68 Mixers can be used with virtually any type amplifier.

Case Dimensions: 2 $\frac{1}{8}$ " high, 11 $\frac{3}{8}$ " wide, 5 $\frac{1}{4}$ " deep.

MODEL M67 Professional Microphone Mixer



Model M67 Professional Microphone Mixer

A compact, lightweight and economical microphone mixer/remote amplifier specifically designed for professional recording and sound reinforcement studio and remote broadcasting. Provides four low-impedance balanced microphone inputs and one line input. The excellent performance and versatility of the M67 make it ideal for use as a complete, compact console for studio, remote, or original installation use—and as an "add-on" mixer for expanding existing facilities and providing additional microphone inputs with tape recorders and VTR's. Built-in tone oscillator provides calibration signal to balance signal levels.

The M67 features line and microphone level outputs; an illuminated VU meter calibrated for +4 and +10 dbm out; extremely low noise and RF susceptibility; wide, flat frequency response; two-level headphone monitor jack. AC or battery operation (see battery pack and other accessories on previous page). Noiseless automatic switchover to battery if AC line fails. **List Price: \$245.00**

M67 SPECIFICATIONS

Frequency Response: ± 2 db from 20 to 20,000 Hz.

Gain: 90 db 150 ohm microphone into 600 ohm line.

Hum and Noise: —125 dbv maximum Equivalent input hum and noise, 20 to 20,000 Hz.

Distortion: Under 1% from 20 to 20,000 Hz. at +10 dbm output, 0.5% typical.

Inputs: Four low-impedance microphones: one line, bridging or 600 ohms.

Outputs and Levels: +18 dbm max., 600 ohm line; —44 dbv max., microphone.

Size and Weight: 2 $\frac{1}{8}$ " x 11 $\frac{3}{8}$ " x 7 $\frac{1}{2}$ "; 4 lbs., 3 oz.

Operating Temperature: 0° to 135° F.

wireless microphones

are cordless and completely self-contained hand-held microphones of unexcelled sensitivity for special-purpose, close-talking and singing use. Especially suited to public use, entertainer purposes, and for mobile situations. No protruding antenna. Portamike's completely transistorized circuit will give years of trouble-free service.



SHOWMAN
PM-3



ENCORE
PM-5

	SHOWMAN PM-3	ENCORE PROFESSIONAL
Microphone pickup element	Controlled Magnetic	Dynamic
Pickup pattern	Omnidirectional	Cardioid
Frequency response	50-12,000 Hz	40-15,000 Hz
Transmitter	All silicon transistor circuitry for stable operation. Tunable at factory from approximately 30 MHz to 47 MHz. Built-in pre-emphasis to match EDCOR receivers. Gives drift free, feed-back free operation; provides flat frequency response from 20 to 20,000 Hz.	
RF Power	200 milliwatts input to final RF amplifier.	
Antenna	No external antenna, hand induced radiation.	
Battery	12-volt mercury TR 289, approximate life 30 hours.	



USED AS
HAND-HELD
MIKE

RUNABOUT
PM-1
(connected as lavalier)

RUNABOUT LAVALIER-TYPE PM-1

EDCOR's 2-in-1 RUNABOUT is a lavalier or clip-type sensitive pickup element with transmitter in belt-clip hand-held unit which provides superb quality and drift-free operation. Its miniature size is especially adaptable for situations where it is desirable to conceal the microphone and/or where it is necessary to have both hands free. Lavalier unit cord unplugs from belt-clip unit and automatically activates it as a hand-held wireless mike.

Microphone pickup element	Omnidirectional capacitive
Frequency response	50-14,000 Hz
Transmitter	All silicon transistor circuitry for stable operation. Tunable at factory from approximately 30 MHz to 47 MHz. Built-in pre-emphasis to match EDCOR receivers. Gives drift free, feed-back free operation; provides flat frequency response from 20 to 20,000 Hz.
Frequency response	Circuit has standard broadcast equalization and is limited only by the response characteristics of the microphone pickup element.
RF power	100 Milliwatts
Antenna	Fully enclosed ferrite type.
Battery life	35 hours



EDCOR SENSATUNER (ST-3)



EDCOR SENSATUNER (ST-3)

The EDCOR Sensatuner is a companion instrument for use with wireless mikes. The finer tuner receives signals from the wireless mike and conveys the sound into a connected public address system or into portable EDCOR speakers. The sensatuner works with any sound system, regardless of make or type.

A compact, rugged set with transistorized circuits and balanced for the included whip antenna. Built-in circuits automatically damp out static and cut off background noise when microphone is not in use.

Sensitivity	2 microvolts for 20 db quieting.
Selectivity	250 Kc.
Signal-to-noise ratio	55 db or better.
Limiting	Full above 3 microvolts.

 **FIDELITY SOUND COMPANY**

EDCOR PORTA-SONIC BRIEF (PS-3)

The most compact, yet most versatile, portable lecture system on the market today. A high-quality sound system completely self-contained in an attractive, water-resistant Samsonite attache case—12" X 18" X 5". Lightweight, can be carried and used anywhere—indoors or outdoors—for small groups of up to 100. Sets up easily in a few minutes for use either on regular AC house current or 12-volt rechargeable battery pack. Movable speaker can be placed to avoid feedback.

Power supply	110-volt, 60-cycle AC line or 12-volt, 4.5-a/h gel-cell battery pack.
Amplifier	15-watt.
Inputs	1. High level for playback from external source, such as tape recorder or record player. 2. Low level for podium microphone or auxiliary cable microphone. 3. Wireless tuner for reception from wireless microphones up to approximately 200 feet.
Output	High level for tape recording or as input to another sound system.
Frequency response	60-10,000 Hz all inputs.
Podium microphone	Omnidirectional, dynamic, with frequency response 60-14,000 Hz.
Operating time	5 to 10 hours on battery pack, depending on volume and consistency of sound.

PORTA-SONIC BRIEF
PS-3



EDCOR SENSATORIUM SS-3

Completely portable public address system with the capacity of auditorium-filling sound. Can be used indoors or outdoors. Rectangular shaft design permits broad horizontal high-frequency dispersion and narrow vertical response which eliminates most feedback problems. Ideal for use with wireless EDCOR mikes. Rechargeable power pack included. Housed in handsome, rugged leatherette case.

Power supply	110-volt, 60-cycle AC line or 12-volt, 4.5 a/h gel-cell battery pack.
Amplifier	20-watt RMS.
Inputs	1. High level for playback from external source, such as tape recorder or record player. 2. Low level for an auxiliary cable microphone. 3. Wireless tuner for reception from wireless microphones up to approximately 200 feet. Either 30 mc or 100 mc tuner is available.
Output	High level for tape recording or as input to another sound system.
Operating time	5 to 10 hours on battery pack, depending on volume and consistency of sound.
Sound radiation pattern	Column Speaker design.
Weight	Approximately 41 pounds.
Dimensions	29" X 15" X 8".

EDCOR SENSATORIUM
SS-3



EDCOR SENSE-PAK SP-3

Portable sound system in compact walnut-finish case. Ideal for use at small meetings of up to 100 people. Used with Sensamike. Unit includes: Tuner with the added facility of a 15-watt amp, cable microphone pre-amp, mixer, rechargeable power supply; plus two special high-compliance, high-efficiency speakers. Mixing facility makes possible use of two microphones, one wired type; the other any EDCOR wireless type. RCA connector permits connection to a tape recorder, for recording or for playback through the 15-watt amp.

FM Tuner	Same as SS-3, using whip antenna.
Inputs	1. High level, high impedance approximately .25V required for 15 watts. RCA type connector. 2. Microphone level, low impedance approximately 2 mv for 15 watts. Cannon XLR female.



EDCOR SENSE-PAK SP-3

Cousino Continuous Loop Tape Units



773.410 SYNCRO-RECORDER

This model is especially suitable for synchronized audio visual projection when coupled with most push button remote controlled slide and filmstrip projectors. Compact, completely transistorized, with all audio record and playback facilities including trip tone recording and playback. The tone may be optionally used for end-of-cycle shut off in place of standard metal foil tabs. Standard features include "on demand" start

with push button, mat switch, capacity switch, and other activating accessories. Built in amplifier and speaker. Equipped with external speaker jack. Power outlet (75 watts) can be turned on or off with message to light up or animate displays. Slide switch for optional continuous and repetitive replay of tapes or automatic shut-off when metal foil tab is located on the tape. Weight 9 lbs. 6" x 6" x 9" long.

Less microphone \$229.95



773.283 SYNCRO-REPEATER

This unit will play back the audio message, as well as the trip tone signal, which may be recorded on the Syncro-Recorder listed above. The Syncro-Repeater has all the features of the Syncro-Recorder except the audio and trip tone record facilities. \$199.95



773.310 RECORDER-REPEATER

Most popular model for recording and playback where recordings are changed frequently. Completely transistorized, with built-in amplifier and speaker. Responds immediately "on demand" from optional push button, foot mat switch or other activating source. Foil strips on tape provide automatic "end of cycle" shut-off. Slide switch provides option of repetitive re-play or "stop-start" operation. \$169.95

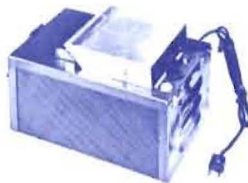

773.000 FAST FORWARD CARTRIDGE MACHINE

This is a high speed (30 inches-per-second) machine which provides fast forward and automatic indexing of any Echo-Matic cartridge which employs a shut-off conductive strip. \$165.00



773.280 AUDIO REPEATER

A popular unit where only playback is required. Used in majority of "on demand" audio requirements. Features "end of cycle" shut-off, all transistor circuitry, built-in amplifier and speaker with jack for remote speaker. \$124.95



773.200 REPEATER

An inexpensive playback unit without amplifier or speaker. A built-in pre-amplifier circuit provides adequate audio power for earphones, phone handsets, or an auxiliary amplifier, such as a P.A. system. (See back page for complete specifications) \$99.95

ECHO-MATIC II TAPE CARTRIDGES

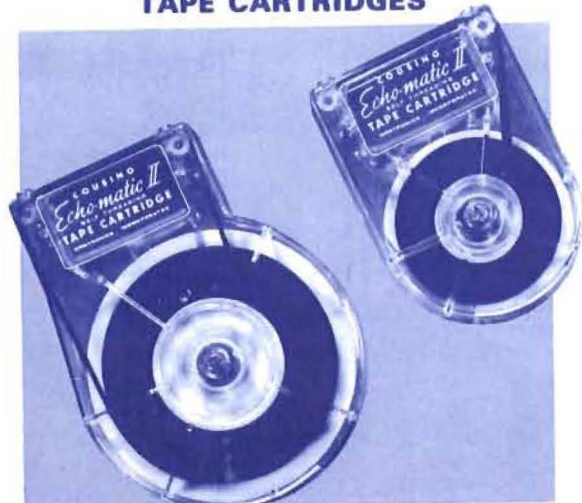

Echo-Matic II cartridges are factory pre-loaded with dependable Friction Free lubricated tape. Play cycle times are available up to 30 minutes at 3-3/4 inches per second tape speed. All Audio Announcers easily convert to 1-7/8 I.P.S. speed, with a simple internal adjustment, which doubles the listed playing times of Echo-Matic II cartridges.

141.070 ... 70 seconds ... \$3.00	141.010 ... 10 minutes ... \$4.25
141.003 ... 3 minutes ... 3.25	141.012 ... 12 minutes ... 4.60
141.005 ... 5 minutes ... 3.50	141.015 ... 15 minutes ... 4.95
141.006 ... 6 minutes ... 3.75	141.000 ... empty ... 2.00
141.008 ... 8 minutes ... 4.00	(15 minute capacity)
143.030 ... 30 minutes ... 5.95	143.000 ... empty ... 3.00
	(40 minute capacity)

FRICION-FREE LUBRICATED TAPE

Available in 900' and 1800' reels. FRICION-FREE™ is the only magnetic tape recommended for use in Echo-Matic cartridges. This is the original lubricated magnetic tape developed especially for use in continuous loop cartridges.

512.090 ... 900' reel ... \$6.15	512.180 ... 1800' reel ... \$11.25
----------------------------------	------------------------------------

143.406 U-TAPE-IT KIT

Tape Cartridge loading kit includes; reel of 450' Friction-Free tape, tape loading disc, empty 143.000 Echo-Matic II cartridge, tape splicing kit, and loading instructions. \$11.95



UHER
by **MARTEL**

**UNIVERSAL
5000**

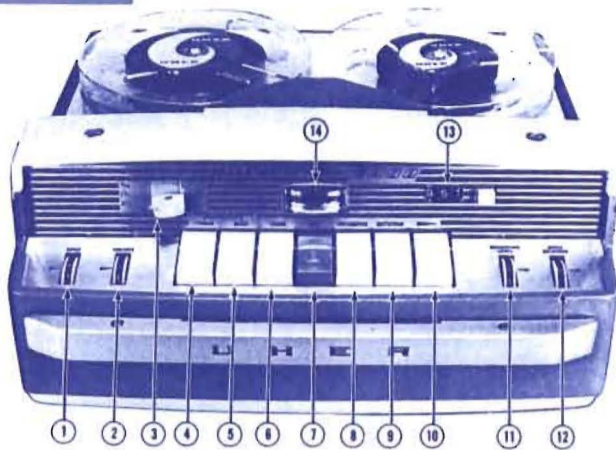

THE WORLD'S MOST VERSATILE TAPE RECORDER, the UHER 5000 used as a fully automatic dictating-transcribing unit, will out-perform any other recorder in its class. The 5000 provides a new and fuller degree of efficiency, fidelity and ease of operation. A single button on the microphone enables you to dictate, stop, listen and rewind to re-record and correct any errors. Transcribing is simple with the foot or typewriter remote control that features stop, start, and rewind. At home record your favorite programs, high fidelity music, eventful newscasts. Through its complete solenoid design, every function can be remotely activated. This feature, combined with its facility for operation without pause, makes its commercial and industrial applications unlimited. The UHER 5000 is used for training, advertising sales aids, message repeater. The UHER 5000 features separate record and playback volume controls, tone control; 3 digit counter with pushbutton reset; automatic stop with metallized leaders; automatic voice level control; jam proof piano type keyboard; full remote control of tape motion; low impedance input, permitting long microphone extension cable; high impedance inputs for microphone, telephone pick up and radio/phone; connection for voice activated relay (AKUSTOMAT); all bearings oil-sealed and fitted with sintered metal sleeves for maintenance free life.

OPERATING FEATURES

- | | |
|---------------------------------|-----------------------------|
| 1. TONE CONTROL | 8. RECORD CONTROL |
| 2. VOLUME CONTROL | 9. DICTATING CONTROL |
| 3. SPEED SELECTOR/ON-OFF SWITCH | 10. FAST FORWARD |
| 4. REWIND) CONTINUOUS PLAYBACK | 11. RECORDING LEVEL CONTROL |
| 5. START | 12. INPUT SELECTOR |
| 6. PAUSE CONTROL | 13. INDEX COUNTER |
| 7. STOP | 14. VU METER |

SPECIFICATIONS

WEIGHT	16 lbs.	WOW & FLUTTER	.15% rms (3 3/4 ips)
SIZE	6 x 10 x 13"	SIGNAL/NOISE RATIO	48db
POWER REQUIREMENTS	110-250v—60 (50) cps	RECORD INPUTS	Microphone—4k ohms
SPEEDS	3 3/4, 1 7/8, 15/16 ips		Radio—47k ohms
TRACKS	Half track monaural		Phono—2 Mohms
TRANSISTORS	10 transistors, 3 diodes	PLAYBACK OUTPUTS	2.5v/4 ohms, 0.9v/4.7k ohms
INDEX COUNTER	3 digit	BIAS FREQUENCY	68 kc
POWER OUTPUT	2 watts—4 ohms	REC/PLAY EQUALIZATION	NARTB
POWER SUPPLY	Built-in	INPUT SENSITIVITY	Microphone—.1 mV
CONTROLS	On-Off switch & speed selector		Radio—1 mV
	Volume		Phono—50 mV
	Tone	RECORDING HEAD(S)	Combi type—3 micron gap
	Record Level	MOTOR	Hysteresis-Synchronous type
FREQUENCY RESPONSE	Input selector switch	DRIVE	Capstan
	3 3/4 ips = 40-16,000 cps ± 2.5db	REEL SIZE	6"
	1 7/8 ips = 40-8,000 cps ± 2.5db	SPEAKER(S)	4 ohms
	15/16 ips = 40-4,000 cps ± 2.5db	OPERATING POSITION(S)	Horizontal (up to 30 degree angle permissible)

Because of the UHER/MARTEL program of continuous development and improvement, the specifications shown are subject to change without notice, and without incurring any obligation to make such changes in tape recorders previously manufactured.

STANDARD ACCESSORIES

Remote control dynamic microphone.
Stop, start, rewind private playback
Steno's typewriter control. Stop, start, backspace/rewind
Remote foot control. Stop, start, backspace/rewind
Telephone microphone
Special Custom telephone adapter
Direct telephone connection
Sound (voice) operated relay

Automatic control switch
Dynamic stetho earphone w/volume control
Transistor mixer. Mixes one low-impedance mike, one high impedance mike, one high impedance medium level input and one high impedance high level input. Includes cable.
DIA-Pilot synchronizes with automatic

slide projectors
Carrying Case—slip cover

AUDIO CABLES

Hi-Z Input/Output cable
External speaker cable
Extension cables for M153 microphone
16 ft.



FIDELITY SOUND COMPANY

1200 18th St., N.W.

296-9110
(Area Code 202)

WASHINGTON, D. C.
(Zip Code 20036)



ATLAS SOUND



ATLAS MICROPHONE STANDS AND ACCESSORIES

ATLAS SOUND microphone stands and accessories are noted for variety, quality and reliable performance. The famous, extra-long clutch for secure, full hand grip is standard on all manual models. Clutch operation is velvet-smooth, wear proof parts are jam free and positive locking; the adjustable tube cannot slip and drop unexpectedly.

New, low profile bases with modern, slim silhouettes are less conspicuous and more functional. Improved designs concentrate base weight at the outer edge for maximum stability. Additional anti-tip bumpers are located between self-leveling, shock-absorbing pads which protect desk, table and floor.

Superchrome plated finishes are lifetime wear and rust resistant. Stand parts and accessories are precision threaded for easy assembly and versatile interchangeability. All models have standard $\frac{1}{8}$ "-27 threads for microphone attachment.

MS-10C Popular, budget-priced floor stand for low cost applications. Sturdy, wrinkle gray base with stability for average weight microphones.

MS-4 Three tubes with two clutches adjust from standard height for adults to special low of 25" for children and seated performers. Ideal for instrumentalists requiring low microphone placement. New, low silhouette base with dark gray wrinkle finish.

MS-11C General purpose, all chrome design with new, low profile base contour and more weight for greater stability. Slim, inconspicuous silhouette is both elegant and modern, suits any decor where styling and appearance are important.

MS-14G Identical to MS-11C, but all gold finished for special decor requirements. Complements both black and gold model microphones.

MS-11S Self-locking version of MS-11C with unique, automatic clutch for effortless, instantaneous changes in height. The stand is adjusted by simply grasping the decorative black control sleeve and raising or lowering the microphone. Removing the hand automatically locks the position. All chrome with new, low profile base.

MS-12C Same general purpose, stable design as new MS-11C, with base finished in dark gray wrinkle.

MS-12S Special, automatic clutch action for easy, quick height adjustments. Identical in size, unique operation and applications to MS-11S, except with wrinkle gray base.

MS-20 Rugged, heavy duty combination for safer support of any microphone. Larger 12", low contour base has more anti-tip weight at the outer edge for maximum stability. Oversize $1\frac{1}{4}$ "- $\frac{7}{8}$ " tube assembly includes adaptor for $\frac{1}{8}$ "-27 threads.

MS-25 Professional floor stand. Integral air suspension system counterbalances microphone weight to prevent out of control crashdown, take effort out of height changes. Air cushioning action is adjustable, floats microphone tube gently down without severe mechanical shock if clutch is accidentally not tightened or released. Heavy duty, gray and chrome base contacts floor on large, 17" circle. Triangular shape and concave sides permit standing close for easy handling without stepping on base. Oversize $1\frac{1}{4}$ "- $\frac{7}{8}$ " tube combination includes $\frac{1}{8}$ "-27 thread adaptor. MS-25 gives maximum stability and safety for all microphones, including the finest and most expensive — at home, on stage and in the studio.

CS-1 Tripod base infinitely adjustable from 10" diameter standing, to 42" circle flat on floor. Reverse-collapses to compact 23" for storage. Useful in restricted space, on uneven surfaces, for clustering microphones and indoor/outdoor portability.

CS-52 Handsome, three-legged floor stand. Combines the slim, less conspicuous appearance of modern, low profile design with large, 15" base stability. Packaged in one, reshippable carton.

CS-42 Similar to CS-52 in design, except that base is readily collapsible for portable use or convenient storage. Packaged in one, reshippable carton.

Model	Type	Height	Base	Tube	Weight
MS-10C	Economy	35" to 63"	10" Gray	Chrome	10 lbs.
MS-4	Wide range	25" to 65"	10" Gray	Chrome	10 lbs.
MS-11C	General use	34" to 62"	10" Chrome	Chrome	13 lbs.
MS-14G	Gold Special	34" to 62"	10" Gold	Gold	12 lbs.
MS-11S	Auto-locking	38" to 62"	10" Chrome	Chrome	13 lbs.
MS-12C	General use	34" to 62"	10" Gray	Chrome	12 lbs.
MS-12S	Auto-locking	38" to 62"	10" Gray	Chrome	12 lbs.
MS-20	Heavy duty	37" to 66"	12" Gray	Chrome	15 lbs.
MS-25	Professional	38" to 67"	17" Gray	Chrome	22 lbs.
CS-1	Collapsible	23" to 62"	Cadmium	Chrome	5 lbs.
CS-52	Three-legged	34" to 62"	15" Gray	Chrome	9 lbs.
CS-42	Portable	34" to 62"	16" Gray	Chrome	8 lbs.

NEW

CS Type Demountable Microphone Floor Stands—with full grip—"Velvet Action," fully collapsible—quick and simple "Come Apart" base design. This new and revolutionary design in microphone stands is ideal for fixed as well as portable applications. Excellent for use when it is desired to contain the stand within the amplifier or speaker carrying case. The stability of the assembled stand is equal to many types employing heavy cast iron base construction. The base legs are easily removed to permit minimum size, lightweight transportation. The spring lock leg-holding mechanism of this ingenious design offers a quick and simple "Come Apart" feature. No tools or screw fastenings are required to hold the base assembly together. No small parts to become lost. The self-leveling legs are chrome plated, tipped with skid-proof rubber shock absorbent bumpers —eliminates vibrational conductivity... protects polished floor surfaces against damage.

Model	Finish	Height Adj.	Shipping Weight
CS-32	Full Chrome	36" to 64"	5 lbs.
CS-33	Full Chrome	26" to 64"	4 lbs.

Each stand is individually packed complete in a single carton. Model CS33 can be collapsed to a total length of only 22 $\frac{1}{2}$ ".

VM-1 SHOCK MOUNT The VM-1 shock mount will eliminate or greatly reduce microphone pick up of external mechanical shock and stand vibrations.

The shock mount is equipped with male and female $\frac{3}{8}$ "-27 threads permitting convenient insertion between the microphone and the microphone stand. The VM-1 is constructed of die castings and brass turnings finished in bright polished chrome — overall length 4 $\frac{3}{4}$ ", diameter 1"

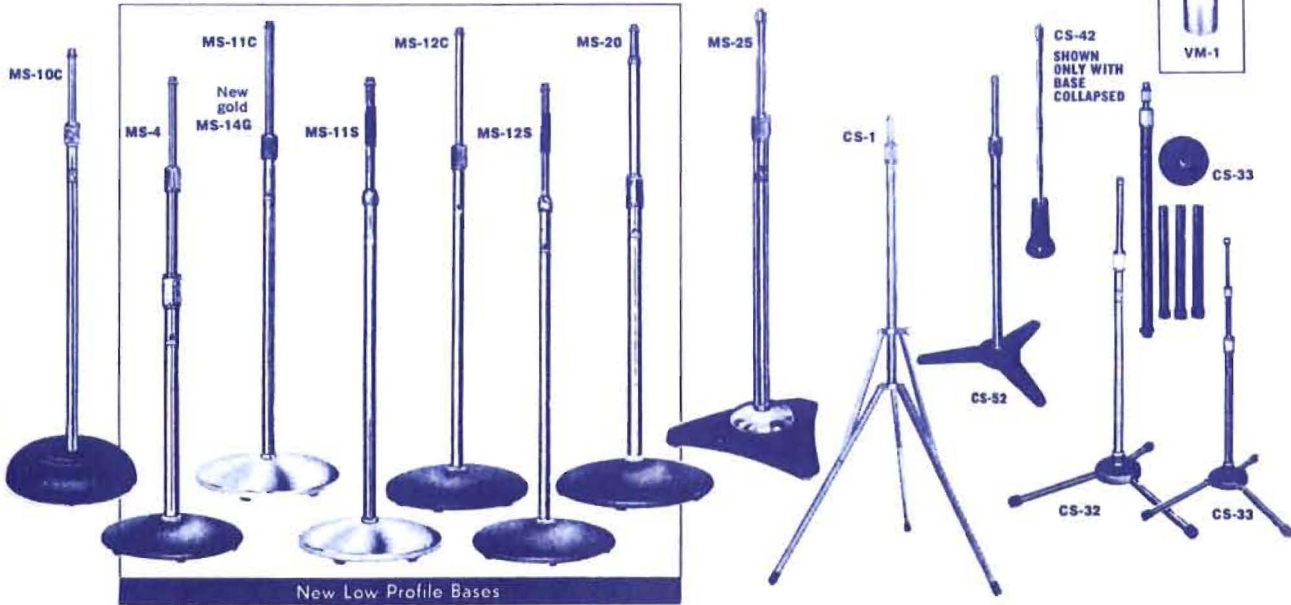
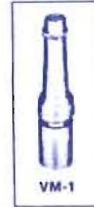

New Low Profile Bases

 **FIDELITY SOUND COMPANY**

Atlas Sound has a full-line variety of public address loudspeakers, microphone stands and accessories. See the complete ATLAS SOUND catalog for all your commercial sound needs...

Paging and Talkback Speakers • Trumpets Units • Weatherproof High Fidelity Speakers • Explosion-Proof Speakers • Sound Columns • Speaker Systems • Baffles • Microphone Stands • Accessories

DS upi tub thr DS Sta Ba: DS Eq Shi OS cor bar pre bui TS de: in DS ett the mi DS mi 3" SB sw rie: sw the wil no SW do



ATLAS SOUND



ATLAS MICROPHONE DESK STANDS AND ACCESSORIES

DS-4 Highly polished molded phenolic base is light beige in color with chrome upright tube. The smooth base will not scratch or mar table tops. Upright tube can be easily removed from base. Base diameter 5", height of tube 4", thread size $\frac{1}{8}$ "-27. Shipping weight $\frac{1}{2}$ lb.

DS-5 Non-Adjustable Desk Stand. Base cast iron, finished in gun metal shivel. Stable base is equipped with pads to prevent damage to desk or table tops. Base diameter 6", tube height 4" chrome finish. Shipping Weight 2 lbs.

DS-7 Same as above but equipped with upright adjustable from 8 to 13 inches. Equipped with standard "Velvet Action" clutch adjustment. Thread $\frac{1}{8}$ "-27. Shipping Weight 3 lbs.

DS-10 "Stream Liner" Desk Stand. Features "Rear Cable Exit". Mike cable is concealed under center section of chrome trim and directed out at rear of base; results in added stability and improved appearance. Constructed of precision die castings, finish gun metal grey, bright chrome trim. Rubber bumpers prevent damage. $\frac{1}{8}$ "-27 thread. Shipping Weight $1\frac{1}{2}$ lbs.

TS-8 Adjustable Banquet Stand. Low silhouette base is a trim, modern design. Upright adjustable from $14\frac{1}{2}$ " to 26". Both base and upright finished in full super-chrome. Shipping wt. $5\frac{1}{2}$ lbs.

DS-9 Professional Desk Stand. Handsome appearance of modern, low silhouette base and tapered upright, both finished in satin chrome, complements the finest microphones. Stable 8" diameter base protects against accidental microphone damage. 4" upright tube. 5 felt base pads (4 lbs.)

DS-14 Desk stand is functionally and aesthetically suited to slim, elongated microphones. Gun-metal shivel finished base with protective felt pads and 3" polished chrome upright tube with $\frac{1}{8}$ "-27 thread (2 lbs.)

SB-1 Dispatcher and Switchboard Mike Support. For use over telephone switchboards, dispatcher's desk, dais, banquet table, etc. 12 inch long, flexible, chrome plated "goose neck" arm is mounted on a spring loaded swivel, can be swung aside when not in use. A feed thru hole is located at the mike end of the "goose neck" so that the mike cable can be concealed within the flexible arm. Base casting is rear loaded so that the base will not tip forward. Finish grey shivel. Shipping Weight 13 lbs.

SW-1 Gyromatic Swivel permits microphone to be adjusted to any angle, up, down, around. Locks in any position. Die cast finished in chrome.

LO-2 "Lock-On" accessory for instantaneous microphone attachment or removal without threading on or off any stand or support. One half of LO-2 remains fastened to the microphone, the other half stays on the stand. Excellent for floor show, sports announcing and similar uses where microphones must often be removed. Positive lock holds microphone safely in hanging positions on booms, ceiling supports and stage battens. Chrome finish.

SO-1 "Snap-On" accessory. Identical to LO-2 but less locking feature. Spring loaded, ball bearing design for secure, safe microphone attachment and quick disconnect on any upright floor stand.

FS-1 Foot Switch for press-to-talk paging applications using any microphone with a single ended input. May also be hand operated on desks and switchboards. Easily rewired for press-to-open circuit requirements.

NS-1 "The Chesty" Neck Supported Mike Holder. Permits a quick and simple "three way" adjustment. Mike is always in a suitably "close talking" position reducing acoustic feedback problems. Wide comfortable chest support prevents rolling due to sudden movement. Cool and lightweight, weighing only 6 oz.

GN "Goose Necks" can be attached to any microphone stand or fixture; ends have $\frac{1}{8}$ "-27 male and female threads—all finished in bright chrome, model numeral indicates overall length of "goose neck" in inches.

US-2 The Atlas US-2 Multi-Purpose microphone support. Excellent for use with language laboratories, dispatcher desks, telephone switchboards, pulpits, etc. The boom arm vertical adjustment and the rotation motion is spring loaded and will "float" the mike in the desired position without requiring a locking adjustment. The microphone cable may be concealed within the boom arm and will feed thru the swivel assembly and base flange. A small opening is provided at the microphone end of the boom for cable entry. Finished in "super-chrome". Specifications—Boom arm length $12\frac{3}{4}$ "; vertical adjustment of boom 180° ; rotation 360° ; base length $2\frac{1}{2}$ ".

BC-1 Bracket Clamp. A multitude of useful applications. Can be used with a boom arm, goose neck, etc. Chrome tube $6\frac{1}{2}$ " long. Clamp can be removed and top flange screwed or bolted in position. $\frac{1}{8}$ "-27 thread.

CH-1 Cable Hanger. Fits all tubes $\frac{7}{8}$ " to $1\frac{1}{4}$ " diameter. The mike cable can be quickly coiled and looped over the cable hanger when moving, storing or transporting the mike and stand. Finished in polished chromium.

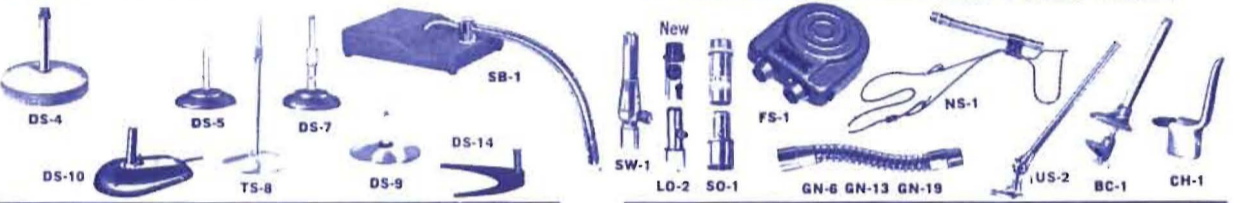

ATLAS BOOM STANDS

BB-1 "Baby Boom" Attachment. Versatile device that can be attached to any type of floor stand. All swivel parts are precision die castings resulting in smooth operation and secure positioning. Length of boom 31"—Chrome plated $\frac{1}{8}$ "-27 thread. Shipping weight $3\frac{1}{2}$ lbs.

BS-36 Professional Boom Stand with "Safety Air Lock Cushion" offers all the advantages of "Floating Action" plus a secure and dependable locking adjustment. The Air Lock built into the vertical section prevents any accidental or sudden slippage of the upright section. A gyromatic swivel joint is provided at the microphone end. The base casting is equipped with shock absorbent chrome plated, "domes of silence". Specifications: Boom length 62" (extension may be added). Vertical extension from 48" to 72". All tubular sections super-chrome plated. Base finished in polished chrome and gun metal. Shipping weight 36 lbs.

BS-36W Mobile Model. Identical to the BS-36 except that the base is supplied with ball bearing swivel casters, permitting the entire stand to be wheeled to various positions in the studio. Shipping weight 40 lbs.

BS-37 Porto Boom. For most exacting TV studio, sound motion picture application, etc., ideal for portable service. Fully collapsible down to dimensions permitting its transportation in all automobiles. Air check prevents any accidental collapse of the upright. Detailed description sheet available. Specifications: Upright retracted $5\frac{1}{4}$ " ft., extended 9 ft. Boom retracted 7 ft., extended 18 ft. All tubular sections aluminum processed in "Alumilite"; Counter weight cast iron with bronze locking mechanism. Base casters 4" swivel type. Base spread 42" on radius. Shipping weight 73 lbs.

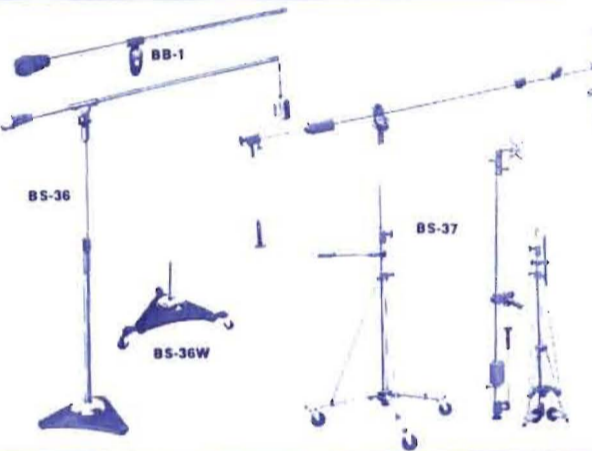

ATLAS MICROPHONE ADAPTORS AND FITTINGS

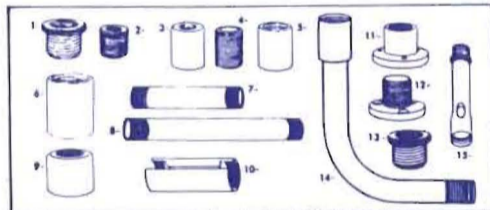

Model	Description
AD-1	$\frac{1}{8}$ "-27 female to $\frac{1}{2}$ " pipe thread male (RCA Adaptor)
AD-2	$\frac{1}{8}$ " pipe female to $\frac{1}{8}$ "-27 male
AD-3	$\frac{1}{8}$ " pipe female to $\frac{1}{8}$ "-27 female
AD-4	$\frac{3}{4}$ " long, $\frac{1}{8}$ "-27 male running thread
AD-5	$\frac{1}{8}$ "-27 female to $\frac{1}{8}$ "-27 female, coupling
AD-6	$\frac{1}{8}$ "-27 female to $\frac{1}{8}$ "-27 female, coupling
AD-7	3" long tube $\frac{1}{8}$ "-27 male each end
AD-8	8" long tube $\frac{1}{8}$ "-27 male each end
AD-9	$\frac{7}{8}$ "-27 female to $\frac{1}{8}$ "-27 female
AD-10	$\frac{1}{8}$ "-24 female to $\frac{1}{8}$ "-27 female (W. E. Adaptor)
AD-11	Flange, $\frac{1}{8}$ "-27 female. Base Diameter $1\frac{1}{4}$ "
AD-12	Flange, $\frac{1}{8}$ "-27 male. Base holes on $1\frac{1}{4}$ " mounting centers
AD-13	$\frac{7}{8}$ "-27 male to $\frac{1}{8}$ "-27 female
AD-14	Right angle bent tube: $\frac{1}{8}$ "-27 male and female each end
AD-15	Cable "Feed-Thru" adaptor: $\frac{1}{8}$ "-27 male and female each end

Note: Thread sizes specified as $\frac{1}{8}$ " pipe is I.P.S. (Electrical fitting) Measures Approx. $\frac{3}{8}$ " dia. All adaptors chrome plated.

 **FIDELITY SOUND COMPANY**

sony recorder price list

Model	Description	Price	See Page
monaural cassette-corders			
TC-40	MINIATURE BATTERY-OPERATED CASSETTE-CORDER With Built-In Condenser Microphone ■ AK-2, DCC-126, FS-6, BE-7, ECM-955	\$ 99.95	2
TC-45	MINIATURE BATTERY OPERATED CASSETTE-CORDER With Built-In Condenser Microphone and Automatic Shutoff ■ AK-3, DCC-126, FS-6, BE-7, RM-15	119.95	2
TC-55	SUB-MINIATURE BATTERY OPERATED CASSETTE-CORDER With Built-In Condenser Microphone and Automatic Shutoff ■ AK-3, DCC-126, FS-6, BE-7, RM-15	139.95	1
TC-66	AC/DC PERSONAL PORTABLE CASSETTE-CORDER ■ FS-6, BE-7, ECM-955 (Replaces TCG)	59.95	3
TC-70	AC/DC PORTABLE CASSETTE-CORDER With Back-Space/Review Button ■ BP-16, DCC-126, FS-6, BE-7, ECM-955	69.95	3
TC-90	AC/DC PORTABLE CASSETTE-CORDER With Built-In Condenser Microphone ■ BP-16, DCC-126, FS-6, BE-7, ECM-955	99.95	3
TC-95	AC/DC EXECUTIVE CASSETTE-CORDER With Built-In Condenser Microphone ■ BP-16, DCC-126, FS-6, BE-7, ECM-955	119.95	3
TC-95L	AC/DC PORTABLE 2-CHANNEL LEARNING LABORATORY CASSETTE-CORDER With Built-In Condenser Microphone ■ HS-23A, BP-16, DCC-126, FS-6, BE-7, ECM-955	149.95	4
TC-110A	AC/DC PORTABLE CASSETTE-CORDER With Built-In Condenser Microphone ■ LC-1, TB-1, BP-9, DCC-126, FS-6, BE-7, ECM-955	129.95	4
TC-140	DELUXE AC/DC PORTABLE CASSETTE RECORDER ■ BP-16, DCC-126, FS-6, BE-7, ECM-955	139.95	4
TC-180-AV	MONOPHONIC CASSETTE-CORDER For Audio-Visual Applications ■ ECM-198, ECM-21, ECM-16, BE-7	169.96	4
stereo cassette and cartridge recorders			
TC-122	ECONOMY STEREO CASSETTE DECK ■ DR-7A, ECM-198, ECM-99, BE-7	115.95	8
TC-126	AC/DC PORTABLE STEREO CASSETTE-CORDER ■ BP-16, DCC-126, FS-6, ECM-198, ECM-99	169.95	6 & 7
TC-126-CS	AC/DC PORTABLE STEREO CASSETTE-CORDER SYSTEM ■ BP-16, DCC-126, FS-6, ECM-198, ECM-99	199.95	6 & 7
TC-127	STEREO CASSETTE DECK ■ DR-7A, ECM-198, ECM-99, BE-7	159.95	8
TC-134SD	DELUXE STEREO CASSETTE DECK With Dolby® System ■ DR-7A, ECM-198, ECM-99, BE-7	239.95	9
TC-161SD	ADVANCED STEREO CASSETTE DECK With Dolby® System ■ DR-6A, ECM-198, ECM-21, ECM-99, BE-7	299.95	9
TC-165	AUTOMATIC-REVERSE STEREO CASSETTE DECK ■ DR-6A, ECM-198, ECM-21, ECM-99, BE-7	219.95	8
TC-228	EIGHT-TRACK STEREO CARTRIDGE RECORDER/PLAYBACK DECK ■ RK-66, DR-7A, ECM-18, ECM-198	169.95	9
car stereo cassette and cartridge players			
TC-10	CAR CASSETTE STEREO PLAYER ■ SS-1, SS-10, SS-11	\$ 99.95	10
TC-20	CAR STEREO CASSETTE PLAYER ■ SS-1, SS-10, SS-11	119.95	10
TC-30	DELUXE CAR STEREO CASSETTE PLAYER With Automatic Reverse ■ SS-1, SS-10, SS-11	149.95	10
TC-84	QUADRADIAL CAR STEREO 8-TRACK CARTRIDGE PLAYER ■ SS-1, SS-10, SS-11	169.95	
monaural reel-to-reel recorders			
TC-105A	DELUXE QUARTER-TRACK MONAURAL TAPE RECORDER ■ ECM-198, ECM-21, ECM-22P, ECM-16	\$ 199.95	13
TC-106AV	HALF-TRACK MONAURAL TAPE RECORDER For Audio-Visual Applications ■ ECM-198, ECM-21, ECM-22P, ECM-16	189.95	13
TC-800B	SERVO-CONTROL AC/DC PORTABLE RECORDER With Built-In Condenser Microphone ■ LC-88, DCC-24W, FS-6, ECM-955, ECM-21, ECM-22P	249.95	12

Model	Description	Price	See Page
stereo reel-to-reel tape systems			
TC-252	ECONOMY STEREO TAPE SYSTEM ■ DR-7A, ECM-198, ECM-21, ECM-99	\$ 239.95	14
TC-353	ECONOMY THREE-HEAD STEREO TAPE SYSTEM ■ DR-7A, ECM-18, ECM-198, ECM-99	349.95	13
TC-630	DELUXE STEREO TAPE SYSTEM/CONTROL CENTER ■ DR-6A, ECM-198, ECM-21, ECM-99	449.95	13
stereo reel-to-reel tape decks			
TC-252-D	STEREO TAPE DECK ■ MX-65, RK-80, DP-2, DR-7A, ECM-198, ECM-99	\$ 159.95	15
TC-353-D	ECONOMY THREE-HEAD STEREO TAPE DECK ■ DR-6A, DP-2A, ECM-198, ECM-21, ECM-99	229.95	15
TC-377	DELUXE THREE-HEAD STEREO TAPE DECK ■ DR-6A, ECM-198, ECM-21	299.95	15
TC-440	AUTOMATIC-REVERSE STEREO TAPE DECK With Roto Bi-Lateral Head ■ DR-6A, ECM-198, ECM-21	399.95	16
TC-580	DELUXE AUTOMATIC-REVERSE STEREO TAPE DECK With Electro Bi-Lateral Heads ■ DR-6A, ECM-21, ECM-22P	499.95	17
TC-640-B	THREE-MOTOR THREE-HEAD STEREO TAPE DECK ■ DR-6A, ECM-21, ECM-22P	399.95	16
TC-650-2	PROFESSIONAL-QUALITY THREE-MOTOR STEREO TAPE DECK Two-Track Record and Play ■ RM-16, H-17-4S, DR-6A, ECM-21, ECM-22P	499.95	16
TC-650-4	PROFESSIONAL-QUALITY THREE-MOTOR STEREO TAPE DECK Quarter-Track Record and Play ■ RM-16, H-17-2S, DR-6A, ECM-21, ECM-22P	499.95	
TC-850-2	PROFESSIONAL-QUALITY THREE-MOTOR STEREO TAPE DECK With 10½" Reel Capacity ■ RM-16, RAD-10, H-60-41S, DR-6A, ECM-21, ECM-22P, MB-8	895.00	17
TC-850-4	PROFESSIONAL-QUALITY THREE-MOTOR STEREO TAPE DECK With 10½" Reel Capacity ■ RM-16, RAD-10, H-60-41S, DR-6A, ECM-21, ECM-22P, MB-8	895.00	17
quadradial reel-to-reel/cartridge			
TC-277-4	QUADRADIAL TAPE DECK ■ ECM-99, DR-7A, HE-2, TP-4S	339.95	19
TC-248-D	QUADRADIAL 8-TRACK CARTRIDGE PLAYBACK DECK ■ CLH-1, HS-2	\$ 169.95	19
TC-654-4	PROFESSIONAL-QUALITY THREE-MOTOR QUADRADIAL TAPE DECK ■ RM-16, DR-6A, ECM-21, ECM-22P (Not illus.)	875.00	
TC-854-4S	PROFESSIONAL-QUALITY THREE-MOTOR QUADRADIAL TAPE DECK With 10½" Reel Capacity ■ RM-16, DR-6A, ECM-21, ECM-22P, RAD-10, MB-8	1,795.00	19
reel-to-reel/cassette stereo tape system			
TC-330	CAN USE ALL ACCESSORIES FOR BOTH REEL TO REEL & CASSETTE RECORDERS (Refer to page 21)	\$349.95	21
cassette-corder®/radio combinations			
CF-200 A	AC/DC CASSETTE-CORDER AM/FM RADIO COMBINATION ■ FS-6, BE-7, ECM-955, ECM-198	\$ 94.95	
CF-350	AD/DC CASSETTE-CORDER AM/FM RADIO COMBINATION With Built-In Condenser Microphone and Automatic Shutoff ■ FS-6, BE-7, ECM-955, ECM-198	129.95	
CF-400	DELUXE AC/DC CASSETTE-CORDER AM/FM RADIO COMBINATION ■ BP-8, DCC-126	119.95	
CF-800	CASSETTE-CORDER AM/FM RADIO COMBINATION ■ ECM-955, RM-15, FS-6, CLH-1, BE-7, HE-2	199.95	

Model
BT-60
CR-60
auto-s
C-30
C-60
C-80M
C-90
C-120
ultra-h
UHF C-60
UHF C-90
UHF C-120
stande
PR-150-3
PR-150-9
PR-150-18
PR-150-36
PR-200-12
PR-200-24
PR-300-6
low no
1 mil p
SLH-100-18
SLH-100-25
SLH-100-36
empty
MTRB-3
MTRB-5
MTRB-7
MTRB-11
Model
ECM-16
ECM-18
ECM-198
ECM-21
ECM-22P
ECM-955
ECM-99
F-98

sony accessory price list

magnetic recording tape

tape recorder accessories

Model	Description	List Price		Model	Description	List Price	See Page
BT-60	60 MINUTE EIGHT-TRACK CARTRIDGE	\$ 3.59		AC-5BW	AC POWER ADAPTER/CHARGER FOR TC-40	\$ 12.95	
CR0-60	60 MINUTE CHROMIUM DIOXIDE TAPE	3.29		AC-9	AC POWER ADAPTER/CHARGER FOR TC-45, TC-55	8.95	
auto-sensor cassette				AC-12	AC POWER ADAPTER FOR MX-12	\$ 12.95	
C-30	30 MINUTE	1.39		AC-148A	48 VOLT PHANTOM POWER SUPPLY FOR ECM-22 P	112.95	23
C-60	60 MINUTE	1.69		AK-1	AC POWER SUPPLY/BATTERY CHARGER WITH NICKEL CADMIUM BATTERY PACK FOR TC-50	27.95	
C-60M	60 MINUTE (Mailer)	2.19		AK-2	AC POWER SUPPLY/BATTERY CHARGER WITH NICKEL CADMIUM BATTERY PACK FOR TC-40	29.95	
C-90	90 MINUTE	2.59		AK-3	AC POWER SUPPLY/BATTERY CHARGER WITH NICKEL CADMIUM BATTERY PACK FOR TC-45, TC-55	29.95	
C-120	120 MINUTE	3.79		BE-7 CASSETTE INSTA-ERASE 24.95			
ultra-high fidelity cassette with auto-sensor				BP-8	NICKEL CADMIUM RECHARGEABLE BATTERY PACK FOR 222-A, 910	14.95	
UHF C-60	60 MINUTES	2.79		BP-9	NICKEL CADMIUM RECHARGEABLE BATTERY PACK FOR 100, 110, 110A	14.95	
UHF C-90	90 MINUTES	3.79		BP-16	NICKEL CADMIUM RECHARGEABLE BATTERY PACK FOR 70, 80, 120, 124, CF-300	14.95	
UHF C-120	120 MINUTES	5.29		BP-22	RECHARGEABLE NICKEL CADMIUM BATTERY PACK FOR TC-40	15.95	
standard 1/4" recording tape, polyester base				BP-23	RECHARGEABLE NICKEL CADMIUM BATTERY PACK FOR TC-45, TC-55	19.95	
PR-150-3	300' ON 3 1/4" REEL 1 MIL	1.59		CLH-1	HEAD CLEANING PEN (Bubble Packed)	1.95	
PR-150-9	900' ON 5" REEL 1 MIL	2.79		CRS-3N	ELASTIC SHOCK MOUNT MICROPHONE SUSPENSION (For 3/4"-1" dia. Microphones)	34.95	
PR-150-18	1800' ON 7" REEL 1 MIL	4.19		DCC-2AW AUTOMOBILE CIGARETTE LIGHTER ADAPTER FOR 560, 560-D AND 800 SERIES 13.95			
PR-150-36	3600' ON 10 1/2" METAL REEL WITH NAB HUB 1 MIL	10.95		DCC-126	AUTOMOBILE CIGARETTE LIGHTER ADAPTER FOR CASSETTE-CORDERS	18.95	
PR-200-12	1250' ON 5" REEL 0.5 MIL	3.99		DP-2A	MOLDED PLASTIC DUST COVER FOR 252-D, 352-D	7.95	
PR-200-24	2400' ON 7" REEL 0.5 MIL	6.79		DP-5	MOLDED PLASTIC DUST COVER FOR TC-440	7.95	
PR-300-6	600' ON 3 1/4" REEL 0.5 MIL	2.29		DP-7	MOLDED PLASTIC DUST COVER FOR 160, 165	7.95	
low noise, high output recording tape, 1 mil polyester base				DR-6A	LOW IMPEDANCE STEREO HEADPHONE	34.95	
SLH-180-18	1800' ON 7" REEL	5.99		DR-7A	LOW IMPEDANCE STEREO HEADPHONE	15.95	
SLH-180-25	2500' BACK COATED ON 10 1/2" METAL REEL WITH NAB HUB	14.50		EC-5M	15' EXTENSION CABLE (Bubble Packed)	3.95	
SLH-180-36	3600' ON 10 1/2" METAL REEL WITH NAB HUB	19.95		EC-10M	30' EXTENSION CABLE (Bubble Packed)	5.49	
empty reel and box				FS-6	FOOT SWITCH (Bubble Packed)	9.95	
MTRB-3	3 1/4" DIA.	0.69		H-17-2S	TWO-TRACK PLUG-IN HEAD BLOCK ASSEMBLY FOR 650-4	109.95	
MTRB-5	5" DIA.	0.79		H-17-4S	QUARTER-TRACK PLUG-IN HEAD BLOCK ASSEMBLY FOR 650-2	109.95	
MTRB-7	7" DIA.	0.99		H-60-21S	TWO-TRACK PLUG-IN HEAD BLOCK ASSEMBLY FOR 850-4	139.95	
MTRB-11	10 1/2" DIA. METAL REEL WITH NAB HUB	5.49		H-60-41S	QUARTER-TRACK PLUG-IN HEAD BLOCK ASSEMBLY FOR 850-2	139.95	
microphones				HE-2	HEAD DEMAGNETIZER (Bubble Packed)	13.95	
ECM-16	TIE-CLASP/LAPEL CONDENSER MICROPHONE	\$34.95	22	HS-23A	LEARNING LABORATORY MICROPHONE HEADSET FOR TC-95 L	22.95	
ECM-18	ECONOMY CONDENSER MICROPHONE	24.95	22	LC-8B	CARRYING CASE FOR 800-B	29.95	
ECM-19B	CARDIOID CONDENSER MICROPHONE	34.95	22	MB-8	19" RACK MOUNTING BRACKET FOR TC-850	79.95	
ECM-21	CARDIOID CONDENSER MICROPHONE	54.95	22	MB-9	19" RACK MOUNTING BRACKET FOR TC-854-4S	99.95	
ECM-22P	CARDIOID CONDENSER MICROPHONE	99.95	23	MX-6S	STEREO MIXER	29.95	
ECM-85S	CARDIOID CONDENSER STOP/START MICROPHONE	24.95	22	MX-12	ACTIVE SIX-CHANNEL STEREO/MONO MIXER	109.95	
ECM-99	CONDENSER ONE-POINT STEREO MICROPHONE	44.95	22	PC-1	PLUG ADAPTER (2 per Bubble Pack)	\$ 2.95	
F-98	CARDIOID DYNAMIC MICROPHONE	10.95	22	PC-2	PLUG ADAPTER (2 per Bubble Pack)	2.95	

sony accessory price list (cont.)

Model	Description	List Price	Model	Description	List Price
tape recorder accessories (cont.)					
RAD-10	10 1/4" REEL ADAPTER FOR TC-850, TC-854-4S	7.95	SS-1	HANG-ON AUTOMOBILE SPEAKERS FOR TC-20	22.95/pr.
RK-36	PATCH CORD (Mini Plug to Alligator Clips) (Bubble Packed)	1.95	SS-10	CAR STEREO SPEAKER SYSTEM FOR TC-10, TC-20, TC-30, TC-84	22.95/pr.
RK-46	PATCH CORD (Phono Plug to Alligator Clips) (Bubble Packed)	1.95	SS-11	DELUXE CAR STEREO SPEAKER SYSTEM FOR TC-10, TC-20, TC-30, TC-84	22.95/pr.
RK-50	PATCH CORD (Mini Plug to Phono Plug) (Bubble Packed)	1.95	TB-1	AUTOMOBILE MOUNTING BRACKET FOR 100, 110, 110A	19.95
RK-68	MAGNETIC PHONO ADAPTER (Bubble Packed)	3.95	TB-2	AUTOMOBILE MOUNTING BRACKET FOR 124	24.95
RK-69	PATCH CORD (Mini-Mini Plug)	1.95	TP-55	TELEPHONE PICK-UP (Bubble Packed)	3.95
RK-74	STEREO PATCH CORD (Phono Plugs) (Bubble Packed)	2.95	special application products		
RK-80	SOUND-ON-SOUND PATCH CORD	1.95	C-37P	VARIABLE-DIRECTIVITY CONDENSER STUDIO MICROPHONE	\$375.00
RM-6	REMOTE VARI-SPEED CONTROL FOR 560, 560-D AND 800 SERIES	9.95	C-77	CONDENSER TELE-MICROPHONE	495.00
RM-11	FULL FUNCTION REMOTE CONTROL FOR TC-780	49.50	C-500	STUDIO-STANDARD CONDENSER MICROPHONE	450.00
RM-15	REMOTE CONTROL STOP/START SWITCH FOR CASSETTE-CORDER ACCEPTING STOP/START MICROPHONES	3.95	ECM-50	TIE-TACK/LAPEL CONDENSER MICROPHONE	149.95
RM-16	FULL-FUNCTION REMOTE CONTROL FOR 650, 850	49.95	ECM-51	TELESCOPIC WAND CONDENSER MICROPHONE	149.95
			ECM-53	CARDIOID CONDENSER MICROPHONE	159.95
			AD-42	WINDSCREEN FOR ECM-50, ECM-51	10.00
			AD-50H	HORIZONTAL MOUNTING CLIP FOR ECM-50	2.50
			AD-50V	VERTICAL MOUNTING CLIP FOR ECM-50	2.50
			AD-51	TIE-TACK MOUNT FOR ECM-50	2.50

Price List

Model	Price	See Page	Model	Price	See Page
BRAUN					
Recorders					
TG-1000 (specify 2 or 4 track)	\$ 749.00	25 & 26	704-T	\$275.00	
Accessories					
TPS 1000 Auto-Rewind Module	69.00		701	\$145.00	
KH 1000 Headphone	75.00		D100	\$ 25.00	
TGF 3 Hand Remote Control	59.00		T200	\$ 25.00	
FS 3B Complete Fidelity Sound Company Foot Pedal (Start/Stop/Backspace)	25.00		Individual Accessories		
TRP 1000 Empty Reels 8-3/4"-Plastic	3.50		D22	\$ 20.00	
TRM 1000 Empty Reels 8-3/4"-Metal	7.50		D28	\$ 4.00	
TQE 1000 4-Channel Playback	149.50		D35	\$ 6.00	
TES 1000 Slide-Movie-Sync.	99.50		D41	\$ 1.00	
TM 1000 Service Manual	3.50		D44	\$ 25.00	
TB 1022 Braun Tape, 3300 ft.	18.90		T46	\$ 15.00	
TP 1000 19" Rack Mount	Price upon request		T59	\$ 9.00	
TE 1000 4th Head Kit	Price upon request		T84	\$ 6.00	
TD 1000 Dust Cover	Price upon request		T95	\$ 1.00	
DORO 700 SERIES					
Dictating/Transcribing Systems					
702-D Dictating unit with dust cover, C60 compact cassette, D100 Kit.	\$275.00	28	DT7	\$ 3.00	
702-T Transcribing unit with dust cover, C60 compact cassette, T200 Kit.	\$275.00		C60	\$ 2.50	
			HC10S	\$ 2.50	
			A34	\$ 15.00	

DORO 300 SERIES

Automatic Telephone Answering Systems

Model	Price	See Page
311	\$345.00	29
320	\$595.00	

Individual Accessories:

A33	Microphone	\$ 6.00
A34	Cassette bulk eraser	\$ 15.00

A53	Transmitter for 320	\$ 50.00
EC20S	20-second endless loop cassette	\$ 6.00
EC30S	30-second endless loop cassette	\$ 6.00
EC-1	1-minute endless loop cassette	\$ 6.00
EC-3	3-minute endless loop cassette	\$ 6.00
EC-6	6-minute endless loop cassette	\$ 6.00
EC-12	12-minute endless loop cassette	\$ 6.00
C60	1-hour leaderless compact cassette	\$ 2.50
C120	2-hour compact cassette	\$ 5.50
HC10S	Cassette head cleaning tape	\$ 2.50
AP-1	Amphenol connector (line 1)	\$ 25.00
AP-2	Amphenol connector (line 2)	\$ 25.00
AP-3	Amphenol connector (line 3)	\$ 25.00
A3215	Interface coupler connector	\$ 25.00
A3225	Interface coupler connector	\$ 25.00

3M

Professional Recorders & Accessories

MODEL	CATALOG NO.	TAPE WIDTH NO. TRACKS	IPS	UNIT PRICE
Series 79				
M79/24	83-0003-0210	2" 24 track	*7.5 - 15	\$28,750.00
M79/16	83-0003-0209	2" 16 track	*7.5 - 15	19,750.00
M79/8	83-0003-0200	1" 8 track	*7.5 - 15	14,750.00
PAR-510, M56/16 Recorder/ Reproducer (includes overdub control.)	83-5995-6008** 83-5995-6010**	2" 16 track 2" 16 track	7.5 - 15 15 - 30	18,995.00
M56/8C	83-5995-6009** 83-5995-6011**	1" 8 track - Convertible	7.5 - 15 15 - 30	15,375.00
M56/8	83-5995-6012** 83-5995-6013**	1" 8 track - N/Convertible	7.5 - 15 15 - 30	11,900.00
PAR-410, M64/4 Recorder/ Reproducer	83-5996-4008** 83-5996-4009**	1/4" Full Track 1/4" Full Track	7.5 - 15 15 - 30	3,200.00 3,200.00
M64/2	83-5996-4004** 83-5996-4005**	1/4" 2 Track 1/4" 2 Track	7.5 - 15 15 - 30	3,500.00 3,500.00
M64/1	83-5996-4000** 83-5996-4001**	1/2" 4 Track 1/2" 4 Track	7.5 - 15 15 - 30	5,500.00 \$ 5,500.00

*Machine also capable of 15 - 30 ips and 5 to 45 ips variable speed.
**Catalog numbers are for 110 - 130 VAC 60 cycle models.
Maximum power consumption is 500 watts (all models).

NOTE: The PAR-410, M64 Recorder/Reproducer equipment may be ordered with provisions for mounting in a standard RETMA rack cabinet in lieu of console mounting at a reduction of \$300.00 from the above prices.

3M (cont.)

Series 79 Conversion Kit

816 expands 8 track to 16 track.....	\$ 7,500.00
824 expands 8 track to 24 track.....	\$17,500.00
1624 expands 16 track to 24 track	\$13,500.00

M56/8C Conversion Kit

Update kit to convert 1" 8 track convertible unit to a 2" 16 track system.
 This kit price is effective for one year from date of purchase, with assistance from Mincom Field Service for installation of kit at no extra charge. \$ 5,950.00
 Kits to be installed after one year warranty period will be quoted upon request.

Selectake

A counter locator for all models 8, 16, and 24 track recorder/reproducers.
 Factory installed model (price when ordered with recorder)..... \$ 895.00
 Field Selectake Kit (price includes Selectake and machine retrofit assembly)..... \$ 1,020.00
 Special price quotations will be given upon request for Selectake units to be used with M23 and M64 recorder/reproducers.

Series 79 Synchronizer/Reader

A synchronizer/reader for the Series 79 Recorders. \$ 8,390.50

SOUNDCRIBER

Model	Price	See Page
S-124-T	\$ 1,250.00	32
S-124-T/VAR	\$ 1,340.00	
S-116-CT	\$ 1,500.00	33
S-124-CT	\$ 1,500.00	
S-116-CT/VAR	\$ 1,580.00	
S-124-CT/VAR	\$ 1,580.00	

Accessories

Demagnetizer	\$ 250.00
Microphone	\$ 65.00
Mixer	\$ 125.00
Tape—Commercial & Military	\$ 11.95
Empty Tape Reel	\$ 1.90
Listening Device	\$ 13.00
Foot Control	\$ 30.00
Speaker 12"	\$ 33.00
Extension Cable 10'	\$ 9.00
Extension Cable 20'	\$ 18.00
Extension Cable 30'	\$ 22.00
Junction Box, 4-position	\$ 30.00
Junction Box, 3-position	\$ 25.00
Connector Cable	\$ 4.50

ELECTRO-VOICE

For Prices See Page 34

SHURE
Microphone Mixers

Model	Price	See Page
M68	\$ 84.00	} 35
M68FC	\$ 90.00	
M67	\$ 162.00	

EDCOR
Wireless Microphones

PM-1	\$ 249.50	} 36
PM-3	\$ 249.50	
PM-5	\$ 299.50	
Receivers & Receiver/Speakers		
ST-3	\$ 237.00	} 37
SS-3	\$ 550.00	
SP-3	\$ 425.00	
Sound Systems		
PS-3	\$ 650.00	

COUSINO

For Prices See Page 38

UHER

Recorder	Model		Price	See Page
5000			\$ 369.00	39
Accessories				
	USA #	GERMAN #	DESCRIPTION	LIST
Earphones				
W212	W212		Dynamic stethoscope ear-phone—includes single ear-phone	\$15.40
Automatic Relay Devices				
817	F411		Akustomat for all models	\$57.75
Telephone Pickups				
802			Telephone pickup for all models	\$10.00
802-S			Special custom telephone adapter	\$11.00
802-G	A261		Direct line connection telephone pickup	\$15.40
Remote Control Switches				
680	F161		Remote hand typewriter control for 5000	\$22.00
690	F261		Remote foot control for 5000, 5500	\$22.00
Carrying Cases				
Z552	Z552		Deluxe carrying case for 5000	\$23.00
671			Slip cover/carrying case for 5000	\$10.70

ATLAS Stands

	Model	Price	See Page
Desk Stands			
DS-4		3.40	} 41
DS-5		4.98	
DS-7		8.20	
TS-8		15.25	
DS-9		11.88	
DS-10		8.98	
DS-14		6.13	
Boom Stands			
BB-1		11.53	} 41
BS-36		99.75	
BS-36W		113.00	
BS-37		1,000.00	
Microphone Floor Stands			
MS-4		23.00	} 40
MS-10C		14.85	
MS-11C		19.30	
MS-11S		35.00	
MS-12C		15.83	
MS-12S		32.00	
MS-20		25.00	
MS-25		40.00	
CS-1A		30.25	
CS-32		18.35	
CS-33		21.63	
CS-42		19.63	
CS-52		17.70	

Prices Subject to Change Without Notice



FIDELITY SOUND COMPANY

1200 18th St., N.W.

296-9110
(Area Code 202)

WASHINGTON, D. C.
(Zip Code 20036)

Tape
it
easy



FIDELITY SOUND COMPANY

1200 18th St., N.W.

296-9110
(Area Code 202)

WASHINGTON, D. C.
(Zip Code 20036)

**FY 1973
COMMERCIAL
CATALOG**

GENERAL SERVICES ADMINISTRATION — FEDERAL SUPPLY SERVICE
AUTHORIZED FEDERAL SUPPLY SCHEDULE PRICE LIST
FSC GROUP 58, PART III, SECTION B

RECEIVED

CONTRACT NUMBER GS-00S-14728

172 1972 14 AM 10:24

Contractor:

Fidelity Sound Company

Federal Supply Class:

5835

Period:

July 27, 1972 through June 30, 1973

Size of Business:

Small

Special Item Numbers:

136-9, 136-24, 136-21

136-22, 136-23

Production Point:

Sony and Braun of foreign origin

Soundsciber produced in USA

Maximum Order Limitation for a Single Order:

Special Item Numbers 136-9 and 136-21

Single Item - \$ 50,000.00

Combination - \$100,000.00

Special Item Numbers 136-22, 136-24, and 136-23

Single or Combination - \$25,000.00

Minimum Order Limitation:

\$10.00

GSA Distribution Code:

00SC-5804

Prompt Payment Discount:

2%/20 Days

All Quantity Discounts:

15%

Time of Delivery:

1-60 Days ARO

Ordering and Payment Address:

Send all orders and payments to contractor only:

FIDELITY SOUND COMPANY

1200-18th Street, N.W.-Suite 105

Washington, D.C. 20036

Guarantee:

All necessary adjustments of machines procured hereunder, not occasioned by accident or misuse, shall be made by the contractor at his own expense, including transportation costs, if any, during the 90-day period after delivery. All machines procured hereunder are guaranteed for a period of 1 year from date of delivery. During the guarantee period, all broken or defective parts not caused by accident or misuse through fault or negligence by the Government, must be replaced (including labor and parts) at the contractor's expense, and including transportation costs, if any.

FOB:

Destination in Continental USA. Add one per cent of order amount for destination to Alaska, Hawaii, and Puerto Rico.

Installation and Instructions:

No installation necessary. Operating instruction book furnished with each recorder.

Electrical Characteristics:

Special Item Number 136-9 and 136-24

All items - 117 v AC 50/60 Hz

Special Item Number 136-21

Sony models TC-10, TC-30, and TC-84 - all 12 v DC

Sony model TC-248D - 117 v AC 50/60 Hz

Export Packing:

Available as an extra item on an open market basis.

Service Points:

Full list of service points furnished with each Sony unit.

Note: The recorders and accessories listed in this authorized price list are the only ones on GSA contract number GS-00S-14728

PLEASE NOTE: FOR SONY MODELS 252 and 800-B UNDER CONTRACT NUMBER GS-00S-14525 see page 8.

CONTRACTOR:



FIDELITY SOUND COMPANY

1200 18th St., N.W.

296-9110
(Area Code 202)

WASHINGTON, D. C.
(Zip Code 20036)

**CONTRACT NUMBER GS-00S-14728 – FSC GROUP 58, PART III, SECTION B
GENERAL SERVICES ADMINISTRATION AUTHORIZED FEDERAL
SUPPLY SCHEDULE PRICE LIST**

SONY TAPE RECORDERS AND ACCESSORIES (INCLUDING MICROPHONES)

SPECIAL ITEM #136-9 (Reel-to-Reel Recorders)

MODEL NO.	Description	Delivered Price
TC-252-D	Economy Stereo Tape Deck	\$ 159.95
TC-353-D	Three-Head Stereo Tape Deck	219.95
TC-277-4	Quadradial Tape Deck	339.95
TC-377	Three-Head Stereo Tape Deck with Ferrite Head and TMS	289.95
TC-440	Automatic-Reverse Stereo Tape Deck	379.95
TC-580	Deluxe Automatic-Reverse Stereo Tape Deck	499.95
TC-850-2	Professional-Quality Three-Motor Stereo Tape Deck 1/2 Track, with 10-1/2" Reel Capacity	895.00
TC-850-4	Professional-Quality Three-Motor Stereo Tape Deck 1/4 Track, with 10-1/2" Reel Capacity	895.00
TC-854-4S	Professional Quality Three-Motor Quadradial Tape Deck	1795.00

SPECIAL ITEM #136-24 (Stereo Cassette & Cartridge Recorders)

MODEL NO.	Description	Delivered Price
TC-126	AC/DC Portable Stereo Cassette-Corder with TMS	169.95
TC-126-CS	AC/DC Portable Stereo Cassette-Corder System with TMS	199.95
TC-134-SD	Stereo Cassette Deck with Dolby Noise Reduction and TMS	239.95
TC-161-SD	Advanced Design Stereo Cassette Deck with Dolby Noise Reduction and TMS	299.95
TC-180-AV	Monophonic Cassette-Corder for Audio-Visual Applications.	169.95
TC-228	Eight-Track Stereo Cartridge Recorder and Playback Deck	169.95
TC-330	Reel to Reel/Cassette Stereo Tape System/Control	(Effective August 23, 1972) 349.95

SPECIAL ITEM #136-21 (Stereo Cassette & Cartridge Players)

MODEL NO.	Description	Delivered Price
TC-10	Car Stereo Cassette Player	99.95
TC-30	Deluxe Car Stereo Cassette Player with Automatic Reverse	149.95
TC-84	Quadradial 4-Channel Car Stereo Eight-Track Cartridge Player	169.95
TC-248-D	Quadradial 4-Channel Eight-Track Cartridge Playback Deck	169.95

CONTRACTOR:



FIDELITY SOUND COMPANY

1200 18th St., N.W.

296-9110
(Area Code 202)

WASHINGTON, D. C.
(Zip Code 20036)

SPECIAL ITEM #136-22 (Accessories)**— Microphones**

MODEL NO.	Description	Delivered Price
ECM-16	Tie-Clasp/Lapel Electret Condenser Microphone	\$ 34.50
ECM-18	Economy Condenser Microphone	24.50
ECM-19B	Cardioid Electret Condenser Microphone	34.50
ECM-21	Cardioid Electret Condenser Microphone	54.50
ECM-22P	Cardioid Electret Condenser Microphone	99.95
ECM-95S	Cardioid Electret Condenser Stop/Start Microphone	24.50
ECM-99	Electret Condenser One-Point Stereo Microphone	44.50

— Accessories

MODEL NO.	Description	Delivered Price
AC-5BW	AC Power Supply for TC-40	12.95
AC-9	AC Power Adapter/Charger for TC-45, TC-55	6.95
AC-12	AC Power Adaptor for MX-12	12.95
AC-148A	Condenser Microphone Phantom Power Supply	112.95
AK-1	AC Power Supply/Battery Charger with Nickel Cadmium Battery Pack for TC-50	27.95
AK-2	AC Power Supply/Battery Charger with Nickel Cadmium Battery Pack for TC-40	29.95
AK-3	AC Power Supply/Battery Charger with Nickel Cadmium Battery Pack for TC-45, TC-55	29.95
BE-7	Cassette Insta-Erase	24.50
BP-8	Nickel Cadmium Rechargeable Battery Pack for CF-400, CF-550	14.95
BP-9	Nickel Cadmium Rechargeable Battery Pack for TC-110A	14.95
BP-16	Nickel Cadmium Rechargeable Battery Pack for TC-126 and TC-126-CS	14.95
BP-22	Nickel Cadmium Rechargeable Battery Pack for TC-40	15.95
BP-23	Nickel Cadmium Rechargeable Battery Pack for TC-45 and TC-55	19.95
CLH-1	Head Cleaning Pen	1.95
CRS-3N	Shock Mount for 3/4" and 1" Diameter Microphones	34.95
DCC-2AW	Automobile Cigarette Lighter Adaptor for 560, 560-D, and 800 series	13.95
DCC-126	Automobile Cigarette Lighter Adapter for Cassette-Corders	18.95
DP-2A	Molded Plastic Dust Cover for 252-D, 352-D	7.95
DP-5	Molded Plastic Dust Cover for TC-440	7.95
DR-6A	Low Impedance Stereo Headphone	34.95
DR-7A	Low Impedance Stereo Headphone	15.50

CONTRACTOR:

**FIDELITY SOUND COMPANY**

1200 18th St., N.W.

296-9110
(Area Code 202)WASHINGTON, D. C.
(Zip Code 20036)

SPECIAL ITEM #136-22 - Accessories (cont.)

MODEL NO.	Description	Delivered Price
EC-5M	15' Extension Cable	\$ 3.95
EC-10M	30' Extension Calbe	5.49
FS-6	Foot Switch	9.75
H-17-2S	Two-Track Plug-In Head Block Assembly for 650-4	109.95
H-17-4S	Four-Track Plug-In Head Block Assembly for 650-2	109.95
H-60-21S	Two-Track Plug-In Head Block Assembly for 850-4	139.95
H-60-41S	Four-Track Plug-In Head Block Assembly for 850-2	139.95
HE-2	Head Demagnetizer	13.50
HS-23A	Learning Laboratory Microphone Headset for TC-95L	22.95
LC-8B	Carrying Case for 800-B	29.95
MB-8	Mounting Bracket - 19" Rack - for TC-850	79.95
MB-9	Mounting Bracket - 19" Rack - for TC-854-4S	99.95
MX-6S	Stereo Mixer	29.95
MX-12	Active Six-Channel Stereo/Mono Mixer	109.95
PC-1	Plug Adapter (Phone Plug to Mini Jack)	2.95/pr.
PC-2	Plug Adaptor (Mini Plug to Phone Jack)	2.95/pr.
RAD-10	10-1/2" Reel Adapter for TC-850 and TC-854-4S	7.95
RK-36	Patch Cord (Mini Plug to Alligator Clips)	1.95
RK-46	Patch Cord (Phono Plug to Alligator Clips)	1.95
RK-50	Patch Cord (Mini Plug to Phono Plug)	1.95
RK-66	Magnetic Phono Adapter	3.95
RK-69	Patch Cord (Mini Jack to Mini Jack)	1.95
RK-74	Stereo Patch Cord	2.95
RK-80	Sound-on-Sound Patch Cord	1.95
RM-6	Remote Vari-Speed Control for 560, 560-D, and 800 Series	9.50
RM-11	Full Function Remote Control for TC-780	49.50
RM-15	Remote Control Stop/Start Switch for Cassette-Corder Accepting Stop/Start Microphones	3.95
RM-16	Full-Function Remote Control for 650, 850	49.95
SS-1	Hang-On Automobile Speakers for TC-20	22.95/pr.
SS-10	Car Stereo Speaker System for TC-10, TC-20, TC-30, and TC-84	22.95/pr.

CONTRACTOR:

**FIDELITY SOUND COMPANY**

1200 18th St., N.W.

296-9110
(Area Code 202)WASHINGTON, D. C.
(Zip Code 20036)

SPECIAL ITEM #136-22 - Accessories (cont.)

MODEL NO.	Description	Delivered Price
SS-11	Deluxe Car Stereo Speaker System for TC-10, TC-20, TC-30, and TC-84	\$ 22.95/pr.
TB-1	Automobile Mounting Bracket for TC-110A	19.95
TB-2	Automobile Mounting Bracket for 124	24.95
TP-5S	Telephone Pick-up	3.95

- Special Application Products (Professional microphones & accessories)

MODEL NO.	Description	
C-37P	Variable-Directivity Condenser Studio Microphone	375.00
C-77	Condenser Tele-Microphone	495.00
C-500	Studio-Standard Condenser Microphone	450.00
ECM-50	Tie-Tack/Lapel Condenser Microphone	149.95
ECM-51	Telescopic Wand Condenser Microphone	149.95
ECM-53	Cardioid Condenser Microphone	159.95
AD-42	Windscreen for ECM-50, ECM-51	10.00
AD-50H	Horizontal Mounting Clip for ECM-50	2.50
AD-50V	Vertical Mounting Clip for ECM-50	2.50
AD-51	Tie-Tack Mount for ECM-50	2.50

CONTRACTOR:

**FIDELITY SOUND COMPANY**

1200 18th St., N.W.

296-9110
(Area Code 202)WASHINGTON, D. C.
(Zip Code 20036)

BRAUN

TAPE RECORDERS AND ACCESSORIES

SPECIAL ITEM #136-9 - (Reel-to-Reel)

MODEL NO.	Description	Delivered Price
TG-1000-4	4-Track Stereo Recorder	\$ 749.00
TG-1000-2	2-Track Stereo Recorder	749.00

SPECIAL ITEM #136-22 - (Accessories)

MODEL NO.	Description	Delivered Price
TPS 1000	Auto-Rewind Module	69.00
KH 1000	Headphone	75.00
TGF 3	Head Remote Control	59.00
FS 3B	Complete FIDELITY SOUND COMPANY Foot Pedal (Start/Stop/Backspace)	25.00
TRP 1000	Empty Reels 8-3/4" - Plastic	3.50
TRM 1000	Empty Reels 8-3/4" - Metal	7.50

CONTRACTOR:

FIDELITY SOUND COMPANY

1200 18th St., N.W.

 296-9110
 (Area Code 202)

 WASHINGTON, D. C.
 (Zip Code 20036)

SOUNDCRIBER

TAPE RECORDERS AND ACCESSORIES

SPECIAL ITEM #136-9 - (Reel-to-Reel)

PART NO.	MODEL NO.	Description	Delivered Price
414000	S-124-T	24 Hour Monitor	\$1,250.00
414004	S-124-T/VAR	24 Hour Monitor with Voice Activated Relay	1,340.00
414010	S-116-CT	16 Hour Reporter	1,500.00
414020	S-124-CT	24 Hour Reporter	1,500.00
414014	S-116-CT W/VAR	16 Hour Reporter with Voice Activated Relay	1,580.00
414021	S-124-CT W/VAR	24 Hour Reporter with Voice Activated Relay	1,580.00

SPECIAL ITEM #136-22 - (Accessories)

PART NO.	Description	Price
411500	Demagnetizer	250.00
411240	Microphone	65.00
411753	Mixer	125.00
411219	Tape - Commercial	11.95
411220	Tape - Military	11.95
411106	Empty Tape Reel	1.90
400385 or		
411385	Listening Device	13.00
411405	Foot Control	30.00
411478	Speaker 12"	33.00
411481	Extension Cable 10'	9.00
411469	Extension Cable 20'	18.00
411483	Extension Cable 30'	22.00
411756	Junction Box, 4-Position	30.00
411486	Junction Box, 3-Position	25.00
411490	Connector Cable	4.50

CONTRACTOR:

FIDELITY SOUND COMPANY

1200 18th St., N.W.

296-9110
(Area Code 202)WASHINGTON, D. C.
(Zip Code 20036)

CONTRACT NO. GS-00S-14525

(SONY MODEL 800-B AND SONY MODEL 252)

**GENERAL SERVICES ADMINISTRATION - FEDERAL SUPPLY SERVICE
 AUTHORIZED FEDERAL SUPPLY SCHEDULE PRICE LIST
 FSC GROUP 58, PART III, SECTION A**

Period:

July 17, 1972 through June 30, 1973

Delivery:

FOB - destination, 1-45 days ARO

Maximum Order Limitation for a single Order:

\$25,000.00

Prompt Payment Discount:

1%/20 days

Send All Orders and Payments to:

FIDELITY SOUND COMPANY
 1200 18th Street, N. W. - Suite 105
 Washington, D.C. 20036

FSS No.	Description	Price 48 Cont. Sts. & DC	Price Alas., P.R. Hawaii
5835-770- 2924	Model 252 - Sony dual channel (monaural & stereo- phonic), type II; with channel selector switch; 7" reels; 3 speeds - 7-1/2, 3-3/4, & 1-7/8 ips, class 3, 4-track, style C; portable, kind B; (meets int. fed. spec. #W-R-00168B)	\$214.00	\$221.00
5835-895- 1874 & 1875	Model 800-B - Sony portable battery tape recorder with built-in AC power supply; 5" reel machine, 7-1/2, 3-3/4, 1-7/8, & 15/16 ips speeds; servocontrol motor; (meets int. fed. spec. #W-R-00170B)	234.90	238.90

NOTE: The prices of the 800-B and 252 recorders listed for this contract are NET prices. No other discounts except for the prompt payment one will be allowed.

CONTRACTOR:

**FIDELITY SOUND COMPANY**

1200 18th St., N.W.

296-9110
(Area Code 202)WASHINGTON, D. C.
(Zip Code 20036)