

# XM-2252HX

## SERVICE MANUAL

US Model  
Canadian Model  
AEP Model  
UK Model



### SPECIFICATIONS

#### POWER OUTPUT AND TOTAL HARMONIC DISTORTION

225/115 watts per channel minimum continuous average power into 4 ohms, both channels driven from 20 Hz to 20 kHz with no more than 0.04% total harmonic distortion per Car Audio Ad Hoc Committee standards.

#### Other Specifications

Circuit system	OTL (output transformerless) circuit	High-pass filter	50 - 200 Hz, -12 dB/oct
Inputs	Pulse power supply RCA pin jacks High level input connector	Low-pass filter	50 - 200 Hz, -12 dB/oct
Outputs	Speaker terminals Through out pin jacks	Low boost	0 - 10 dB (40 Hz)
Speaker impedance	1* - 8 $\Omega$ (stereo) 2* - 8 $\Omega$ (when used as a bridging amplifier)	Power requirements	12 V DC car battery (negative ground)
Maximum outputs (HI-CURRENT/HI-VOLTAGE)	250/500 W $\times$ 2 (at 4 $\Omega$ ) 600/1200 W (monaural) at 4 $\Omega$	Power supply voltage	10.5 - 16 V
Rated outputs (HI-CURRENT/HI-VOLTAGE) (supply voltage at 14.4 V)	115/225 W $\times$ 2 (20 Hz - 20 kHz, 0.04 % THD, at 4 $\Omega$ ) 150/300 W $\times$ 2 (20 Hz - 20 kHz, 0.1 % THD, at 2 $\Omega$ ) 300/600 W (monaural) (20 Hz - 20 kHz, 0.1 % THD, at 4 $\Omega$ )	Current drain	at rated output: 55 A (4 $\Omega$ HI-VOLTAGE mode) Remote input: 2 mA
Frequency response	5 Hz - 100 kHz ( $\pm$ 3dB)	Dimensions	Approx. 258 $\times$ 50 $\times$ 500 mm (10 <sup>1</sup> / <sub>4</sub> $\times$ 2 $\times$ 19 <sup>3</sup> / <sub>4</sub> in.) (l/h/p) not incl. projecting parts and controls
Harmonic distortion	0.005 % or less (at 1kHz, 4 $\Omega$ )	Mass	Approx. 5.4 kg (11 lb. 15 oz.) not incl. accessories
Input level adjustment range	0.2 - 4.0 V (RCA pin jacks) 0.4 - 8.0 V (High level input)	Supplied accessories	Mounting screws (4), Terminal cap (1)
		Design and specifications are subject to change without notice.	

\* HI-CURRENT only

## STEREO POWER AMPLIFIER

# SONY®



## TABLE OF CONTENTS

Specifications .....	1
<b>1. SERVICING NOTE</b> .....	2
<b>2. GENERAL</b> .....	3
<b>3. ELECTRICAL ADJUSTMENTS</b>	
Self-Diagnosis Function .....	7
Idling Adjustment .....	8
<b>4. DISASSEMBLY</b>	
5-1. Bottom Plate, Panel (Front), Panel (Rear) Removal .....	9
5-2. AMP/Power Board Removal .....	9
<b>5. DIAGRAMS</b>	
5-1. IC Block Diagrams .....	10
5-2. Printed Wiring Board – Amplifier Section – .....	11
5-3. Schematic Diagram – Amplifier Section – .....	13
5-4. Printed Wiring Board – Power Section – .....	15
5-5. Schematic Diagram – Power Section – .....	17
<b>6. EXPLODED VIEWS</b> .....	19
<b>7. ELECTRICAL PARTS LIST</b> .....	21

## SECTION 1 SERVICING NOTE

### CANCELLING THE PROTECTOR DURING SERVICING

Cut JW213 on the amplifier board to cancel the protector.  
After servicing always be sure to return JW213 to its original state.

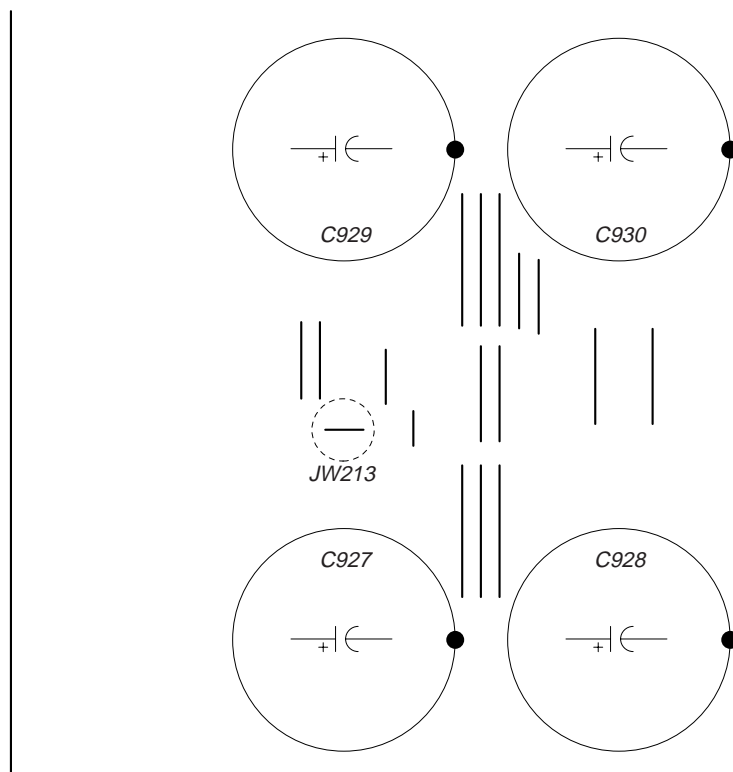

# SECTION 2 GENERAL

This section is extracted from instruction manual.

## Features

- Maximum power output of 500 watts per channel (at 4 Ω).
- This unit can be used as a bridging amplifier with a maximum output of 1200 watts.
- Direct connection can be made with the speaker output of your car audio if it is not equipped with the line output (High level input connection).
- Built in variable LPF (Low-pass filter), HPF (High-pass filter), and low boost circuit.
- Dual mode connection possible for a multi-speaker system.
- You can switch between HI-CURRENT mode (1 - 2 Ω) and HI-VOLTAGE mode (2 - 4 Ω).
- Protection circuit and indicator provided.
- Pulse power supply\* for stable, regulated output power.

- New circuit which drives the speaker directly and removes the source resistance from the final MOS FET output stage.

**Pulse power supply**  
The unit has a built-in power regulator which converts the power supplied by the DC 12 V car battery into high speed pulses using a semiconductor switch. These pulses are stepped up by the built-in pulse transformer and separated into both positive and negative power supplies before being converted into direct current again. This is to regulate fluctuating voltage from the car battery. This light weight power supply system provides a highly efficient power supply with a low impedance output.

## Caractéristiques

- Puissance de sortie maximale de 500 watts par canal (à 4 Ω).
- Cet appareil peut être utilisé comme amplificateur de pontage d'une sortie maximale de 1200 watts.
- Une connexion directe est possible avec le sortie haut-parleur de votre autoradio si celle-ci n'est pas équipée d'une sortie de ligne (connexion d'entrée haut niveau).
- Filtre passe-bas (LPF), filtre passe-haut (HPF) variables et circuits d'amplification des graves intégrés.
- Double mode de connexion possible au moyen d'un système à plusieurs haut-parleurs.
- Possibilité de commutation des modes HI-CURRENT (1 - 2 Ω) et HI-VOLTAGE (2 - 4 Ω).
- Avec circuit et indicateur de protection.
- Alimentation électrique par impulsions\* pour une puissance de sortie stable, régulée.

- Nouveau circuit supprimant la résistance source du niveau de sortie MOS FET final et entraîne directement le haut-parleur.

**Alimentation électrique par impulsions**  
Cet appareil est équipé d'un régulateur de puissance intégré qui convertit la puissance fournie par une batterie de voiture de 12 V CC en impulsions ultrarapides au moyen d'un commutateur à semi-conducteur. Ces impulsions sont amplifiées par le transformateur d'impulsions intégré et séparées en alimentation positive et négative avant d'être reconverties en courant continu. Ce processus permet de compenser les fluctuations de tension provenant de la batterie de la voiture. Ce système d'alimentation de faible poids assure une alimentation électrique très efficace pour une sortie

## Location and Function of Controls

- MODE indicator**  
Indicates HI-CURRENT mode or HI-VOLTAGE mode.
- POWER/PROTECTOR indicator**
  - OVER CURRENT lights up in green during normal operation. The color will change from green to amber when receiving a powerful signal.
  - OFF SET lights up green during normal operation. The color will change from green to amber when the voltage out put to the Speaker terminal or the Pin Jack is too high.
  - THERMAL lights up in green during normal operation. The color will change from green to amber when the temperature rises to an unsafe level. The color will return to green when the temperature returns to normal.
- LEVEL adjustment control**  
The input level can be adjusted with this control when using source equipment made by other manufacturers. Turn it to MAX when the output level of the car audio seems low.
- LOWBOOST level control**  
Turn the control to boost the frequencies around 40 Hz to a maximum of 10 dB.
- Cut-off frequency adjustment control**  
Sets the cut-off frequency (50 - 200 Hz) for the low-pass or high-pass filters.
- FILTER selector switch**  
When the switch is in the LPF position, the filter is set to low-pass. When in the HPF position, the filter is set to high-pass.
- HI-CURRENT/HI-VOLTAGE mode switches (located on the bottom of the unit)**  
Remove the bottom cover to access the switch.
  - In HI-CURRENT mode the speaker impedance is 1 to 2 Ω. This mode needs a signal via parallel circuits for a powerful sound.
  - In HI-VOLTAGE mode a speaker impedance is 2 to 4 Ω. In this mode you can enjoy clear sound with the dynamic range.
 Both switches must be set to the same position.

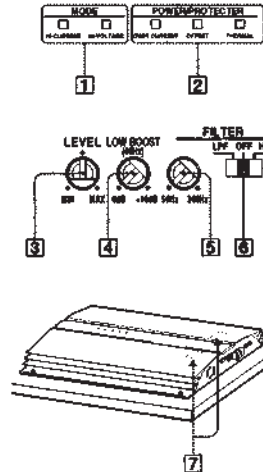

## Emplacement et fonction des commandes

- Indicateur MODE**  
L'indicateur signale le mode activé : HI-CURRENT ou HI-VOLTAGE.
- Indicateur POWER/PROTECTOR**
  - OVER CURRENT s'allume en vert en cours de fonctionnement normal. La couleur passe du vert à l'ambre lors de la réception d'un signal puissant.
  - OFF SET s'allume en vert en cours de fonctionnement normal. La couleur passe du vert à l'ambre lorsque la tension transmise via la borne Speaker ou la prise Pin est trop élevée.
  - THERMAL s'allume en vert en cours de fonctionnement normal. La couleur passe du vert à l'ambre lorsque la température dépasse le niveau de sécurité. La couleur repasse au vert dès que la température est revenue à un niveau normal.
- Commande de réglage LEVEL**  
Le niveau d'entrée peut se régler avec cette commande lors de l'utilisation d'équipements source d'autres fabricants. Mettez-le sur MAX lorsque le niveau de sortie de l'installation audio paraît faible.
- Commande de niveau LOW BOOST**  
Tournez cette commande pour amplifier les fréquences autour de 40 Hz à un maximum de 10 dB.
- Commandes de réglage de la fréquence de coupure**  
Réglez la fréquence de coupure (50-200 Hz) des filtres passe-bas ou passe-haut.
- Sélecteur FILTER**  
Lorsque le commutateur est en position LPF, le filtre est mis sur passe-bas. Lorsqu'il est en position HPF, le filtre est mis sur passe-haut.
- Commutateur de mode HI-CURRENT/HI-VOLTAGE (situé sur le dessous de l'appareil)**  
Déposez le couvercle inférieur pour accéder au commutateur.
  - En mode HI-CURRENT, l'impédance de haut-parleur est de 1 à 2 Ω. Ce mode transmet un signal via des circuits parallèles pour créer un son de forte amplitude.
  - En mode HI-VOLTAGE, l'impédance de haut-parleur est de 2 à 4 Ω. Ce mode vous permet d'obtenir un son clair dans la plage dynamique.
 Les commutateurs doivent être réglés sur la même position.

## LOW BOOST

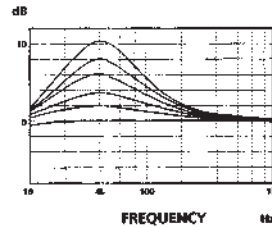

## Cut-off frequency/Fréquence de coupure

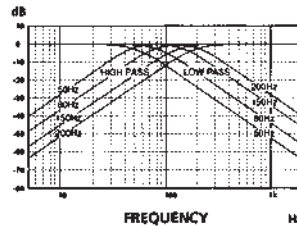

## Circuit Diagram/Schéma du circuit

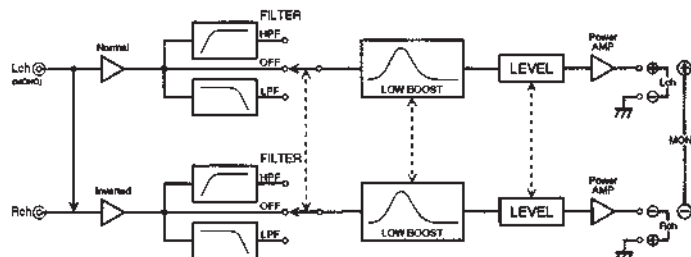

# Connections

# Connexions

## Caution

- Before making any connections, disconnect the ground terminal of the car battery to avoid short circuits.
- Be sure to use speakers with an adequate power rating. If you use small capacity speakers, they may be damaged.
- Do not connect the  $\ominus$  terminal of the speaker system to the car chassis, and do not connect the  $\ominus$  terminal of the right speaker with that of the left speaker.
- Install the input and output cords away from the power supply lead as running them close together can generate some interference noise.
- This unit is a high-powered amplifier. Therefore, it may not perform to its full potential if used with the speaker cords supplied with the car.
- If your car is equipped with a computer system for navigation or some other purpose, do not remove the ground wire from the car battery. If you disconnect the wire, the computer memory may be erased. To avoid short circuits when making connections, disconnect the +12 V power supply lead until all the other leads have been connected.

Make the terminal and connector connections as illustrated below.

**Note**  
When you tighten the screw, be careful not to apply too much torque\* as doing so may damage the screw.

\* The torque value should be less than 1 N·m.

Pass the leads through the cap, connect the leads, then cover the terminals with the cap.

Flat-head screwdriver  
Tournevis à lame plate

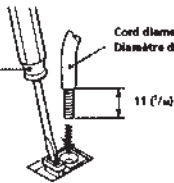

Cord diameter 0.3 - 1.25 mm (AWG 22 - 16)  
Diamètre du cordon : 0,3 - 1,25 mm (AWG 22 - 16)

11 (1/4)

Unit: mm (in.)  
Unité: mm (po.)

## Attention

- Avant d'effectuer les connexions, débranchez la borne de masse de la batterie de voiture pour éviter tout court-circuit.
- Veillez à utiliser des haut-parleurs de puissance adéquate. Si vous utilisez des haut-parleurs de faible capacité, ils risquent d'être endommagés.
- Ne raccordez pas la borne  $\ominus$  du système de haut-parleurs à la carrosserie de la voiture ni la borne  $\ominus$  du haut-parleur droit avec celle du haut-parleur gauche.
- Éloignez les câbles d'entrée et de sortie du câble d'alimentation pour éviter les interférences.
- Cet appareil est un amplificateur de haute puissance. Il ne peut donc déployer sa pleine puissance que si les câbles de haut-parleurs de la voiture lui sont raccordés.
- Si votre voiture est équipée d'un système de navigation ou d'un ordinateur de bord, ne retirez pas le fil de terre de la batterie de la voiture, sinon les données mémorisées seront effacées. Pour éviter un court-circuit lorsque vous effectuez les branchements, branchez le câble d'alimentation +12 V après avoir branché tous les autres fils.

Établissez les connexions de la borne et du connecteur comme illustré ci-dessous.

**Remarque**  
Ne serrez pas la vis selon un couple\* trop fort car vous pourriez l'endommager.

\* La valeur du couple de serrage doit être inférieure à 1 N·m.

Faites passer les fils par le cache, raccordez les fils et recouvrez les bornes avec le cache.

## 2-Speaker System Système à 2 haut-parleurs

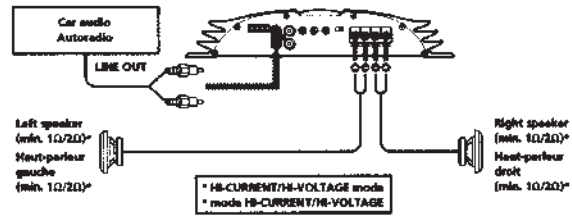

For details on the settings of switches and controls, refer to "Location and Function of Controls."

Pour plus de détails sur les réglages des commutateurs et commandes, reportez-vous à "Emplacement et fonction des commandes".

## As a Monaural Amplifier Comme amplificateur monaural

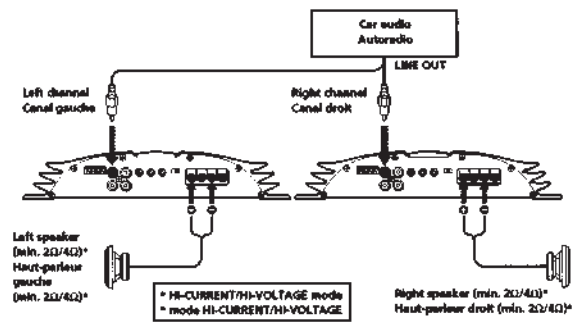

For details on the settings of switches and controls, refer to "Location and Function of Controls."

Pour plus de détails sur les réglages des commutateurs et commandes, reportez-vous à "Emplacement et fonction des commandes".

**Note**  
Make sure that the line output from the car audio is connected to the jack marked "L (MONO)" on the unit.

**Remarque**  
Vérifiez que la sortie de ligne de l'autoradio est raccordée à la prise portant l'indication "L (MONO)" sur l'appareil.

## Power Connection Leads Câbles d'alimentation

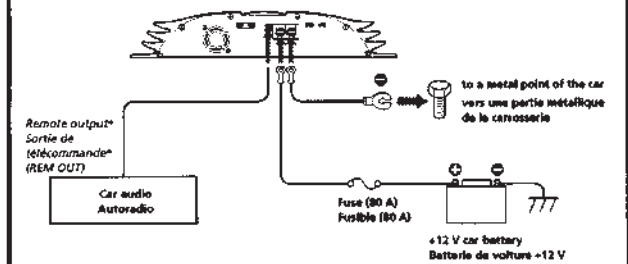

- If you have the factory original or some other car audio without a remote output on the amplifier, connect the remote input terminal (REMOTE) to the accessory power supply.
- Si vous disposez du modèle d'origine ou d'un autre autoradio dont l'amplificateur ne comporte pas de sortie de télécommande, raccordez la borne d'entrée de télécommande (REMOTE) à la prise d'alimentation accessoires.

- Notes on the power supply**
- Connect the +12 V power supply lead only after all the other leads have been connected.
  - Be sure to connect the ground lead of the unit securely to a metal point of the car. A loose connection may cause a malfunction of the amplifier.
  - Be sure to connect the remote control lead of the car audio to the remote terminal.
  - When using a car audio without a remote output on the amplifier, connect the remote input terminal (REMOTE) to the accessory power supply.
  - Use the power supply lead with a fuse attached (80 A).
  - Place the fuse in the power supply lead as close as possible to the car battery.
  - Make sure that the leads to be connected to the +12 V and GND terminals of this are larger than 4-Gauge (AWG-4) or a the sectional area of more than 22 mm<sup>2</sup>.
  - When using the optional RC-46 power amplifier connecting cord, consult that manual for proper use.

- Remarques sur l'alimentation électrique**
- Raccordez le câble d'alimentation +12 V uniquement après avoir réalisé toutes les autres connexions.
  - Raccordez correctement le fil de masse à une partie métallique de la voiture. Une connexion lâche peut provoquer un dysfonctionnement de l'amplificateur.
  - Veillez à raccorder le fil de télécommande de l'autoradio à la borne de télécommande.
  - Si vous utilisez un autoradio dont l'amplificateur ne comporte pas de sortie de télécommande, raccordez la borne d'entrée de la télécommande (REMOTE) à la prise d'alimentation accessoires.
  - Utilisez un câble d'alimentation muni d'un fusible (80 A).
  - Fixez le fusible du câble d'alimentation le plus près possible de la batterie de voiture.
  - Vous devez raccorder des câbles de calibre supérieure à 4 (AWG-4) ou d'une section supérieure à 22 mm<sup>2</sup> aux bornes +12V et GND.
  - Lorsque vous utilisez le cordon de raccordement pour amplificateur RC-46 en option, consultez le manuel pour une utilisation correcte.

## As the Monaural Amplifier for a Subwoofer Comme amplificateur monaural pour un haut-parleur d'extrêmes graves

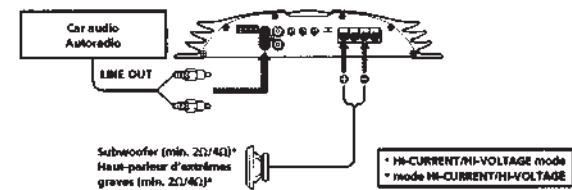

For details on the settings of switches and controls, refer to "Location and Function of Controls."

Pour plus de détails sur les réglages des commutateurs et commandes, reportez-vous à "Emplacement et fonction des commandes".

**Note**  
If you wish to use a subwoofer as a monaural speaker, connect the speaker as illustrated above. The output signal to the subwoofer will be the combination of both right and left output signals.

**Remarque**  
Si vous désirez utiliser un haut-parleur d'extrêmes graves comme haut-parleur monaural, raccordez le haut-parleur comme illustré ci-dessus. Les signaux de sortie vers le haut-parleur d'extrêmes graves seront une combinaison des signaux de sortie droit et gauche.

## 2-way System Système à 2 voies

Two output channels  
Deux canaux de sortie

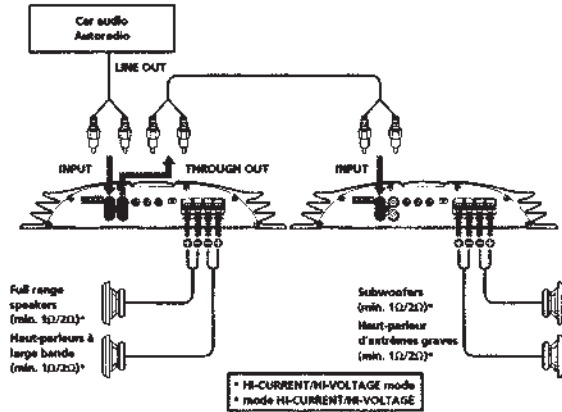

Use the THROUGH OUT terminal when you install more amplifiers. The signals are output as they were input. (LOW BOOST, HPF, LPF do not work.)

### Notes

- A maximum 3 amplifiers can be connected to the THROUGH OUT terminal. If you connect more than three amplifiers, it may cause problems such as sound dropout.
- A high level input connection cannot use THROUGH OUT.

Utilisez la borne THROUGH OUT lorsque vous installez plusieurs amplificateurs. Les signaux sont sortis comme ils sont entrés. (LOW BOOST, HPF, LPF ne fonctionnent pas.)

### Remarque

- Vous pouvez raccorder un maximum de 3 amplificateurs à la borne THROUGH OUT. Si vous raccordez plus de trois amplificateurs, cela peut provoquer des problèmes comme des baisses du son.
- Avec une connexion d'entrée de haut niveau, vous ne pouvez pas utiliser THROUGH OUT.

## Four output channels Quatre canaux de sortie

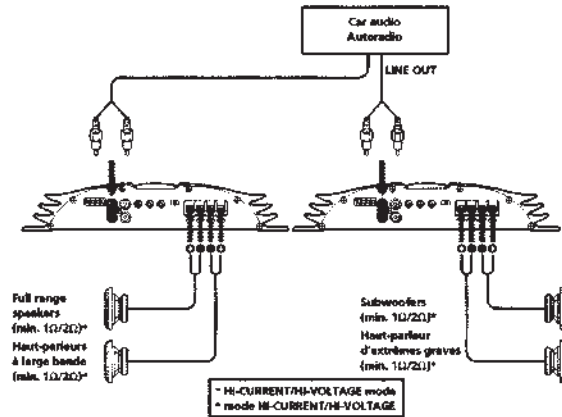

For details on the settings of switches and controls, refer to "Location and Function of Controls"

### Note

In this system, the volume of the subwoofers will be controlled by the car audio fader control

Pour plus de détails sur les réglages des commutateurs et commandes, reportez-vous à "Emplacement et fonction des commandes"

### Remarque

Dans ce système, le volume des haut-parleurs d'extrêmes graves est contrôlé par la commande de balance avant/arrière de l'autoradio.

## Dual Mode System (With a Bridged Subwoofer) Double mode de connexion (avec un haut-parleur d'extrêmes graves en pont)

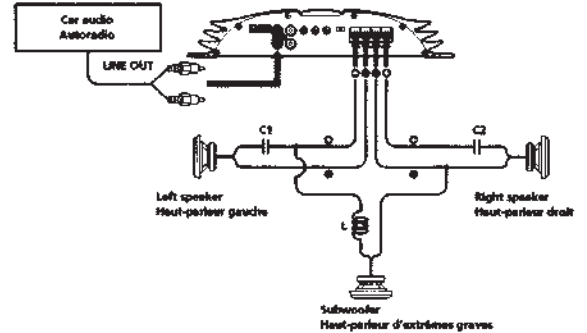

Table of crossover values for  
6 dB/octave (4 ohms)

Crossover Frequency unit: Hz	L (coil)* unit: mH	C1/C2 (capacitor)* unit: µF
50	12.7	800
80	8.2	500
100	6.2	400
130	4.7	300
150	4.2	270
200	3.2	200
250	2.4	150
400	1.6	100
600	1.0	68
800	0.8	50
1000	0.6	39

\* (not supplied)

Tableau des valeurs de recoupement  
pour 6 dB/octave (4 ohms)

Fréquence de recoupement unit: Hz	L (bobine)* unit: mH	C1/C2 (condensa- teur)* unit: µF
50	12,7	800
80	8,2	500
100	6,2	400
130	4,7	300
150	4,2	270
200	3,2	200
250	2,4	150
400	1,6	100
600	1,0	68
800	0,8	50
1000	0,6	39

\* (non fournis)

### Notes

- When using passive crossover networks in a multi-speaker system, care must be taken as the speaker system's impedance should not be lower than that of the suitable impedance for this unit.
- When you are installing a 12 decibelloctave system in your car, the following points must be considered. In such a circuit, there will be an increase in the current which bypasses the speaker with frequencies at around the crossover frequency. If audio signals are continued to be fed into the crossover frequency area, it may cause the amplifier to become abnormally hot or the to will be blown. Also if the speaker is disconnected, a series-resonant circuit will be formed by the choke and the capacitor. In this case, the impedance in the resonance area will decrease dramatically resulting in a short circuit-like situation causing damage to the amplifier. Therefore, make sure that a speaker is connected to such a circuit at all times.

### Remarque

- Lorsque vous utilisez des circuits de recoupement de fréquence passifs dans un système à plusieurs haut-parleurs, assurez-vous que l'impédance du système n'est pas inférieure à celle prévue pour cet appareil.
- Lorsque vous installez un système à 12 décibelloctave dans votre voiture, vous devez respecter les points suivants. Dans un système à 12 décibelloctave où la bobine d'arrêt et le condensateur sont utilisés en série pour former un circuit, vous devez réaliser les branchements avec beaucoup de précaution. Dans ce type de circuit, une augmentation du courant contourne le haut-parleur se produit dans les fréquences se situant autour de la fréquence de coupure. Si des signaux audio continuent d'être fournis dans la zone de la fréquence de recoupement, une surchauffe risque de se produire dans l'amplificateur et le fusible risque de sauter. Si le haut-parleur n'est pas raccorder, un circuit de résonance série sera créé par la bobine et le condensateur. Dans ce cas, l'impédance dans la zone de résonance sera considérablement réduite, et comme dans le cas d'un court-circuit, l'amplificateur peut être endommagé. Par conséquent, veillez à ce qu'un haut-parleur soit toujours raccorder au circuit.

## High Level Input Connection

(As a Monaural Amplifier for a Subwoofer)

Connexion d'entrée à haut niveau  
(Comme amplificateur monaural pour un haut-parleur d'extrêmes graves)

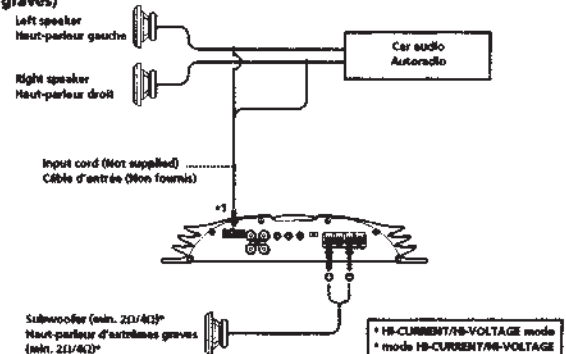

For details on the settings of switches and controls, refer to "Location and Function of Controls"

### Note

If you wish to use a subwoofer as a monaural speaker, connect the speaker as illustrated above. The output signal to the subwoofer will be the combination of both the right and left output signals.

Pour plus de détails sur les réglages des commutateurs et commandes, reportez-vous à "Emplacement et fonction des commandes"

### Remarque

Si vous désirez utiliser un haut-parleur d'extrêmes graves comme haut-parleur monaural, raccordez le haut-parleur comme illustré ci-dessus. Les signaux de sortie vers le haut-parleur d'extrêmes graves seront une combinaison des signaux de sortie droit et gauche.

**High Level Input Connection (2-Speaker System)**  
**Connexion d'entrée à haut niveau**  
 (Système à 2 haut-parleurs)

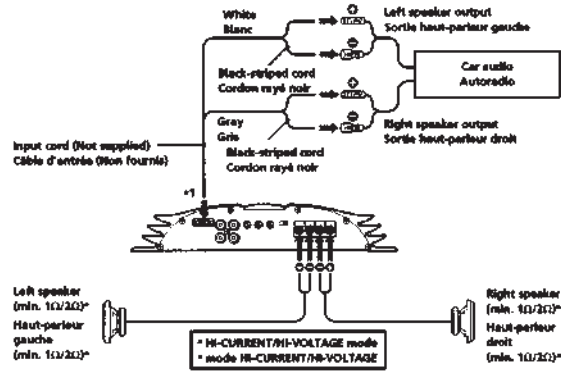

For details on the settings of switches and controls, refer to "Location and Function of Controls." *Pour plus de détails sur les réglages des commutateurs et commandes, reportez-vous à "Emplacement et fonction des commandes".*

**High Level Input Connection (As a Monoaural Amplifier)**  
**Connexion d'entrée à haut niveau**  
 (Comme amplificateur monoaural)

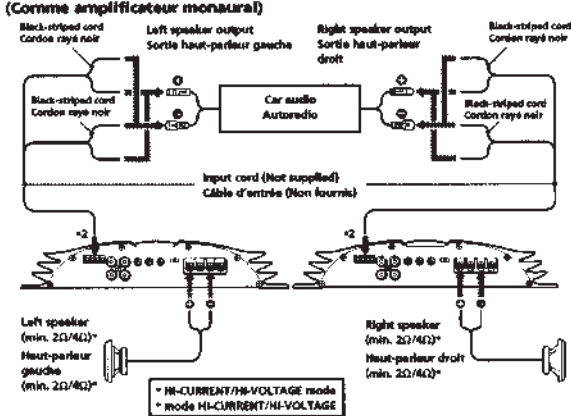

For details on the settings of switches and controls, refer to "Location and Function of Controls." *Pour plus de détails sur les réglages des commutateurs et commandes, reportez-vous à "Emplacement et fonction des commandes".*  
**Note**  
 Make sure that the line output from the car audio is connected to the jack marked "1 (MONO)" on the unit. *Remarque*  
 Vérifiez que la sortie de ligne de l'autoradio est raccordée à la prise portant l'indication "1 (MONO)" sur l'appareil.

**Speaker cord direct in connector**  
**Cordon de haut-parleur directement dans le connecteur**

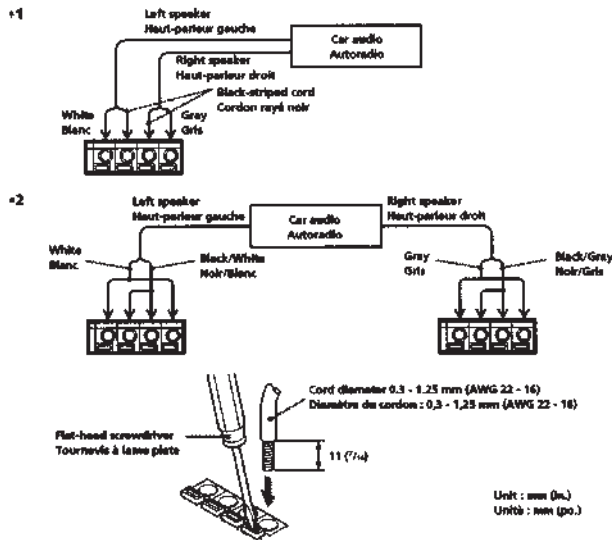

## SECTION 3 ELECTRICAL ADJUSTMENTS

### SELF-DIAGNOSIS FUNCTION

In addition, this unit comes with a function which alerts when settings of the Hi-Current and Hi-Voltage modes are wrong. There are two switches at the base of this unit to switch to the Hi-Current and Hi-Voltage modes respectively. When these two switches are not set to the same modes, the Hi-Current and Hi-Voltage indicators on the top panel change from green to amber to indicate an error.

"See INSTRUCTION MANUAL for more information."

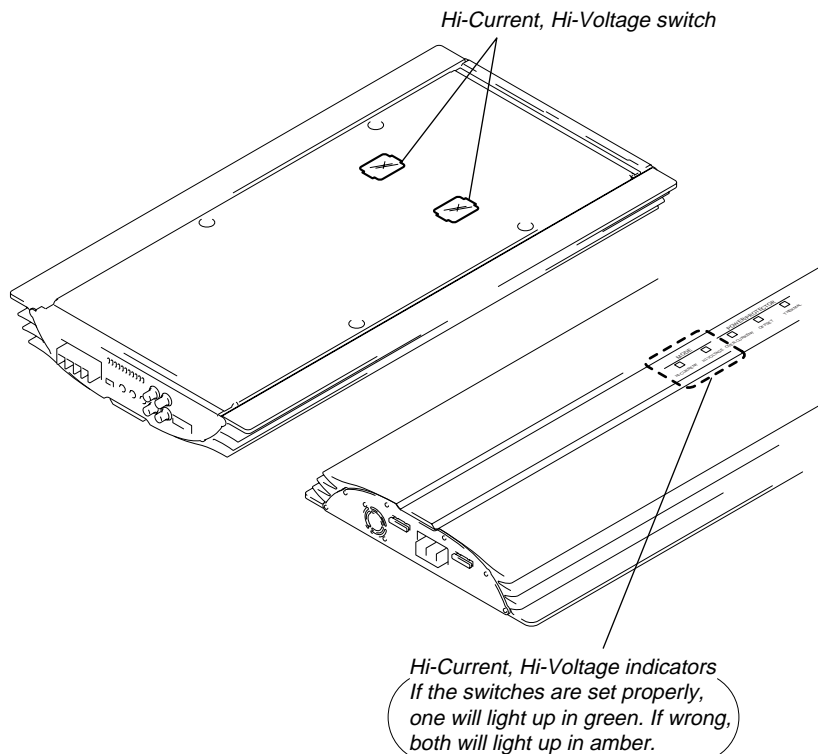



## IDLING ADJUSTMENT

### • L-CH (R-CH) Adjusting Method

#### Connection:

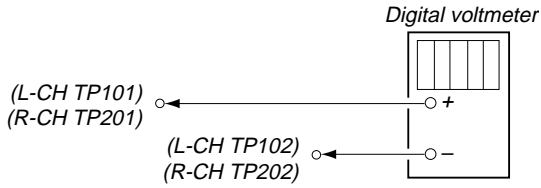

#### Procedure:

1. Rotate the semi-fixed resistor VR101 (R-CH is VR201) completely in the counterclockwise direction as seen from the component side.
  - The large variable range of the semi-fixed resistor prevents flow of excessive current to the output MOS-FET.
  - Take note that when an excessive current flows, the protectors operate (both the amber and green lamps light up at the same time) and the amplifier will stop operating.

#### Adjustment Location:

– AMP/POWER Board – (Component side)

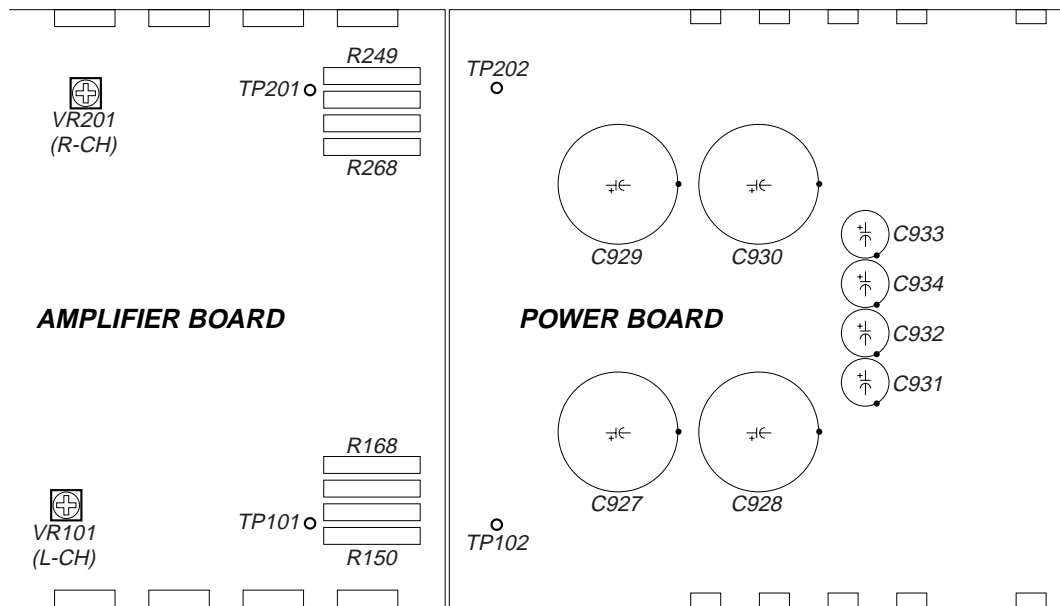

2. Set the input signal setting to non-signal.
3. Apply a 14.4V power supply voltage between the +12V and REMOTE terminals and GND terminal.
4. Adjustments
 

Connect a digital voltmeter between the two terminals of the cement resistors R149 and R150 (0.03 Ω) indicated as TP101 and TP102 (TP201 and TP202 for R-CH).

Rotate the semi-fixed resistor VR101 and adjust so that the voltage between TP101 and TP102 comes between 0.5 mV and 1.1 mV with 0.8 mV as the center.

Adjust R-CH in the same way.

- Perform adjustments carefully as voltage changes are minute.
- When adjusting from the component side, rotating the semi-fixed resistor control in the clockwise direction increases the idling current while rotating in the counterclockwise direction decreases the idling current.



## SECTION 4 DISASSEMBLY

**Note :** Follow the disassembly procedure in the numerical order given.

### 4-1. BOTTOM PLATE, PANEL (FRONT), PANEL (REAR) REMOVAL

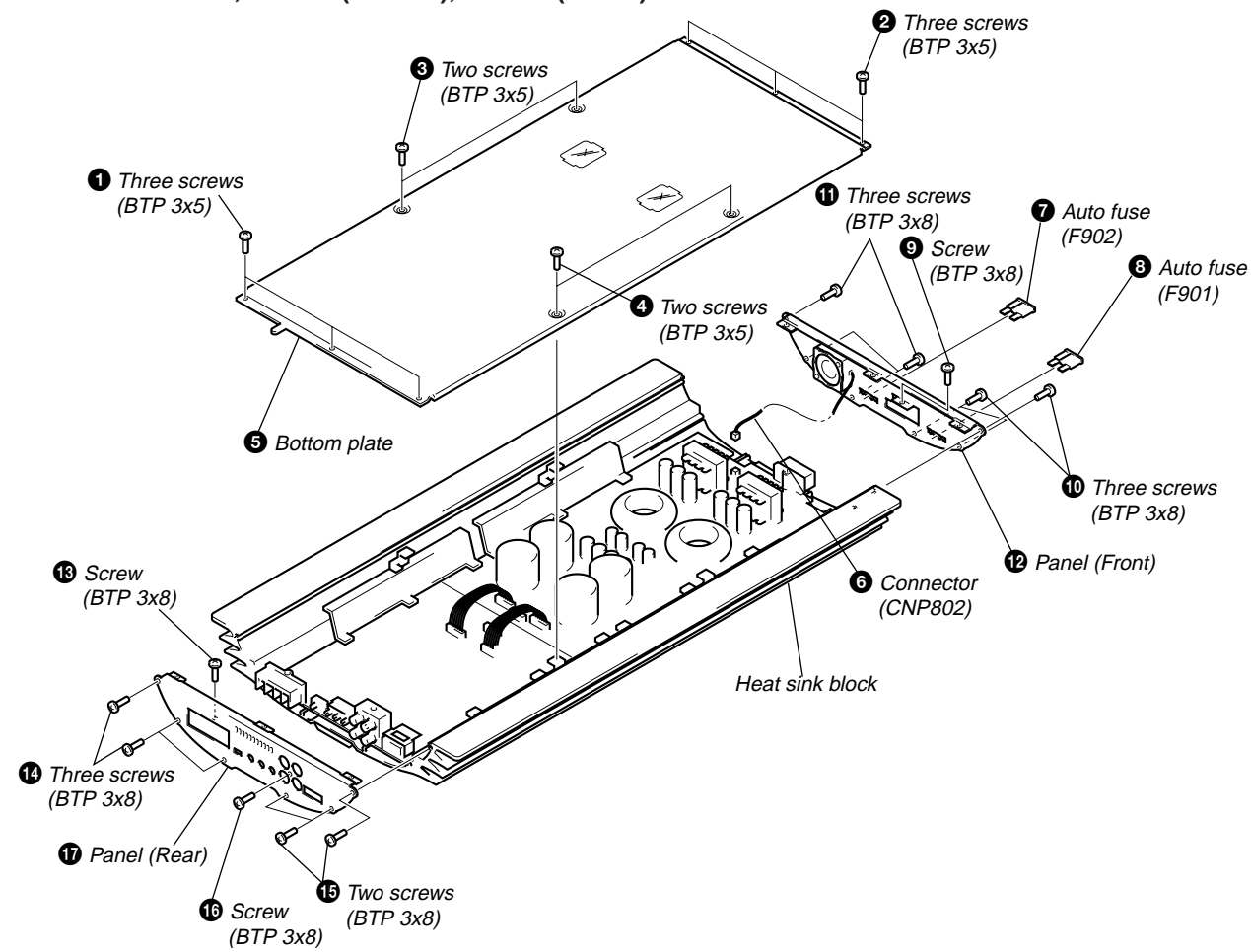

### 4-2. AMP/POWER BOARD REMOVAL

**Note :**  
Amplifier board and Power board are not separated because the board is long and heavy. Take care not to damage the board when removing.

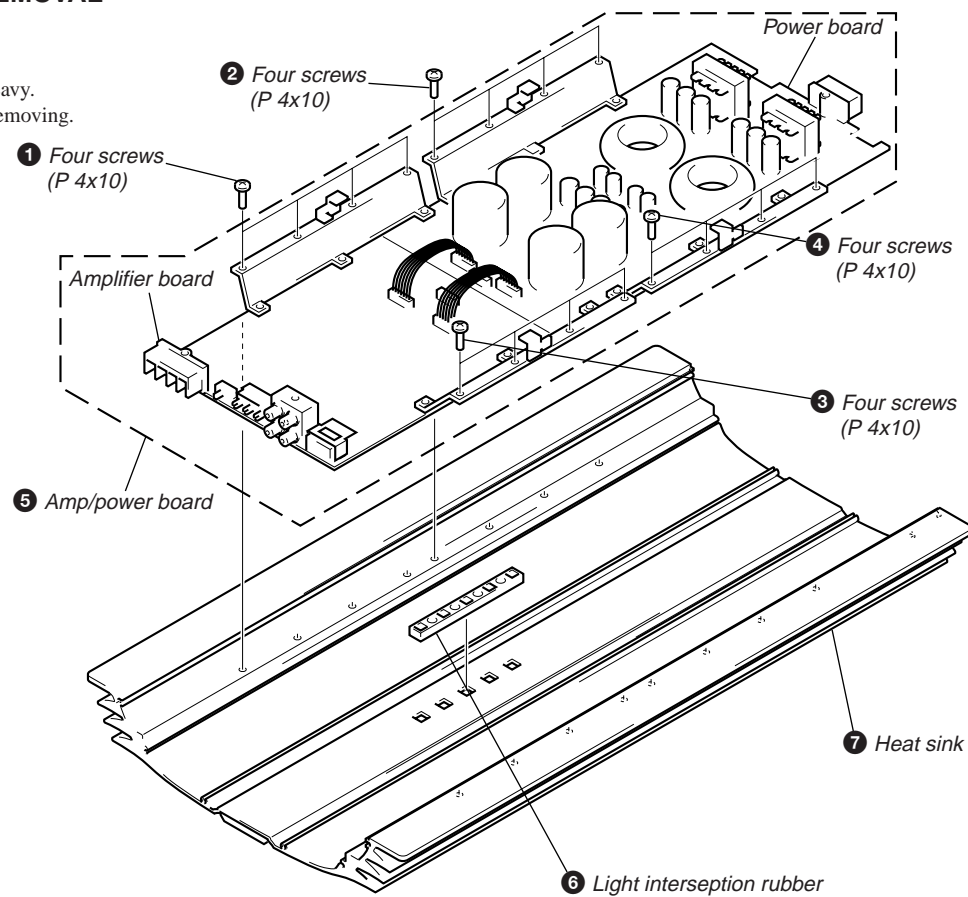

## SECTION 5 DIAGRAMS

**THIS NOTE IS COMMON FOR PRINTED WIRING BOARDS AND SCHEMATIC DIAGRAMS.**  
(In addition to this, the necessary note is printed in each block.)

**For schematic diagrams.**

**Note:**

- All capacitors are in  $\mu\text{F}$  unless otherwise noted. pF:  $\mu\text{F}$  50 WV or less are not indicated except for electrolytics and tantalums.
- All resistors are in  $\Omega$  and  $1/4$  W or less unless otherwise specified.
- $\Delta$  : internal component.
- $\square$  : panel designation.
- $\square$  B+ : B+ Line.
- Power voltage is dc 14.4V and fed with regulated dc power supply from ACC and BATT cords.
- Voltage and waveforms are dc with respect to ground under no-signal conditions.
- no mark : POWER ON
- \* : Impossible to measure
- Voltages are taken with a VOM (Input impedance  $10\text{M}\Omega$ ). Voltage variations may be noted due to normal production tolerances.
- Waveforms are taken with an oscilloscope. Voltage variations may be noted due to normal production tolerances.
- Circled numbers refer to waveforms.
- Signal path.
- $\Rightarrow$  : AUDIO

**For printed wiring boards.**

**Note:**

- $\circ$  : parts extracted from the component side.
- $\Delta$  : internal component.

### • WAVEFORMS

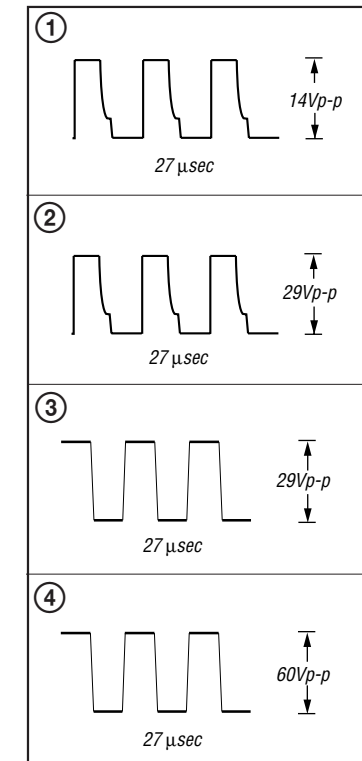

### 5-1. IC BLOCK DIAGRAMS

#### IC101- 103, 201- 203 NJM4580E

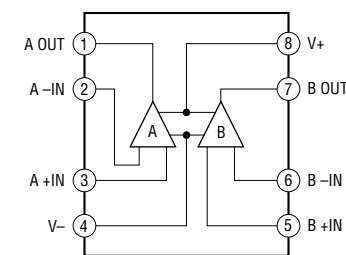

#### IC901 $\mu\text{PC494GS}$

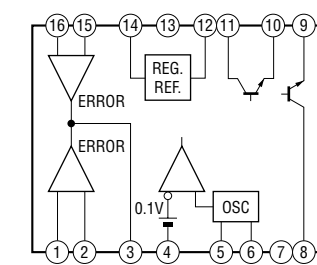

• Semiconductor Location

5-2. PRINTED WIRING BOARD – AMPLIFIER SECTION –

Ref. No.	Location
D101	A-8
D102	A-5
D103	C-6
D104	C-6
D105	A-9
D201	G-7
D202	F-6
D203	E-6
D204	E-6
D205	G-9
D801	C-8
D802	C-8
D803	D-8
D804	E-9
D930	C-7
D931	C-7
D932	E-7
D933	E-7
IC101	B-2
IC102	D-3
IC103	C-2
IC201	B-3
IC202	E-4
IC203	D-2
IC807	E-8
IC902	C-8
Q101	C-2
Q102	D-6
Q103	C-6
Q104	C-6
Q105	C-6
Q106	C-6
Q107	C-6
Q108	C-6
Q109	A-6
Q110	A-7
Q111	A-8
Q112	A-5
Q113	A-6
Q114	C-6
Q115	C-6
Q116	C-7
Q117	C-6
Q118	B-8
Q119	A-8
Q120	B-8
Q121	B-8
Q201	D-3
Q202	D-6
Q203	E-6
Q204	E-6
Q205	E-6
Q206	E-6
Q207	E-6
Q208	E-6
Q209	G-6
Q210	G-7
Q211	G-8
Q212	G-6
Q213	G-5
Q214	E-6
Q215	E-6
Q216	E-7
Q217	E-6
Q218	F-8
Q219	G-8
Q220	F-8
Q221	F-8
Q801	C-8
Q802	C-8
Q803	C-7
Q804	B-7
Q805	C-8
Q806	D-8
Q807	D-9
Q808	D-8
Q809	D-8
Q810	E-8
Q811	E-8
Q812	E-7
Q813	E-7

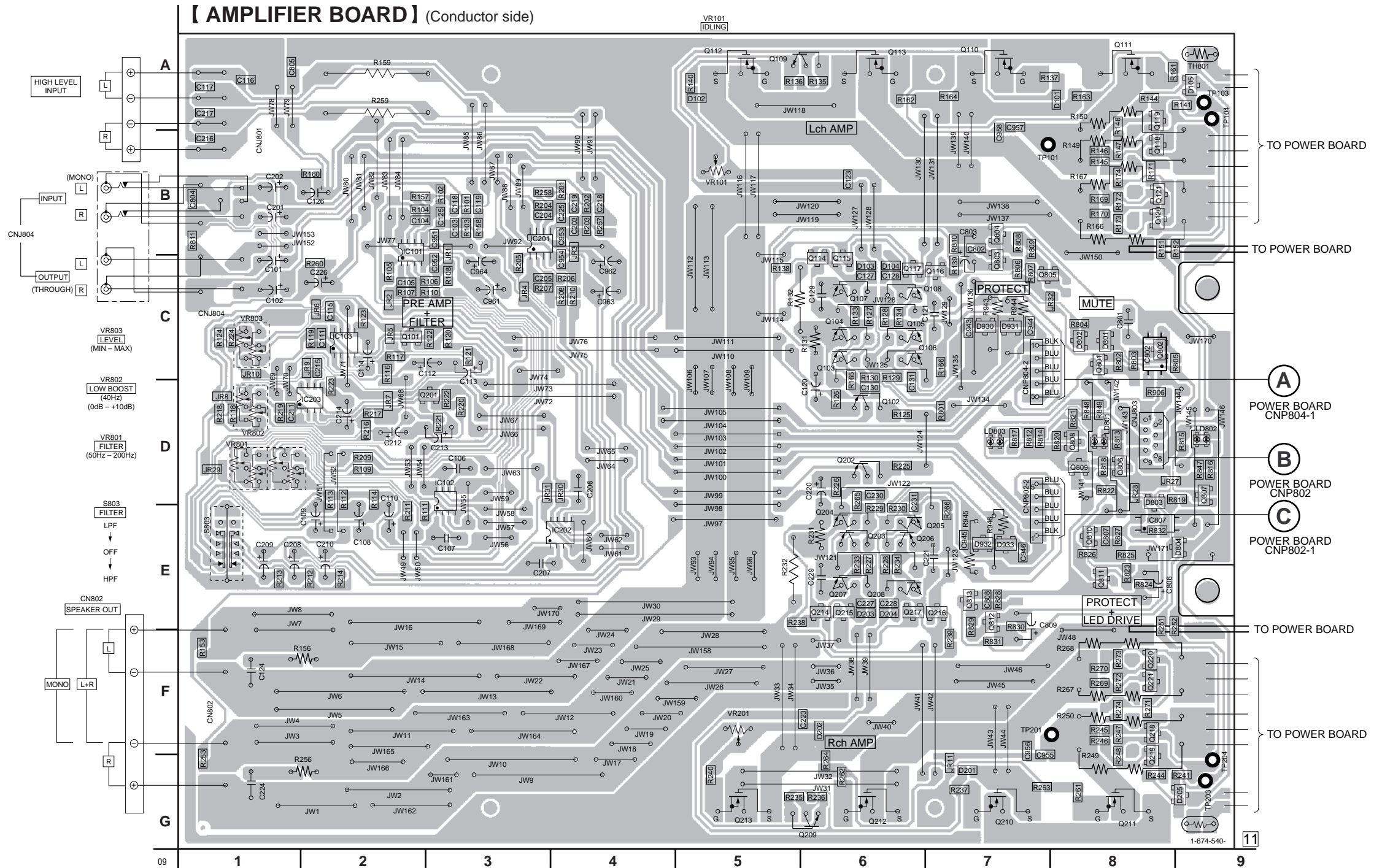

5-3. SCHEMATIC DIAGRAM – AMPLIFIER SECTION –  
• See page 10 for IC Block Diagrams.

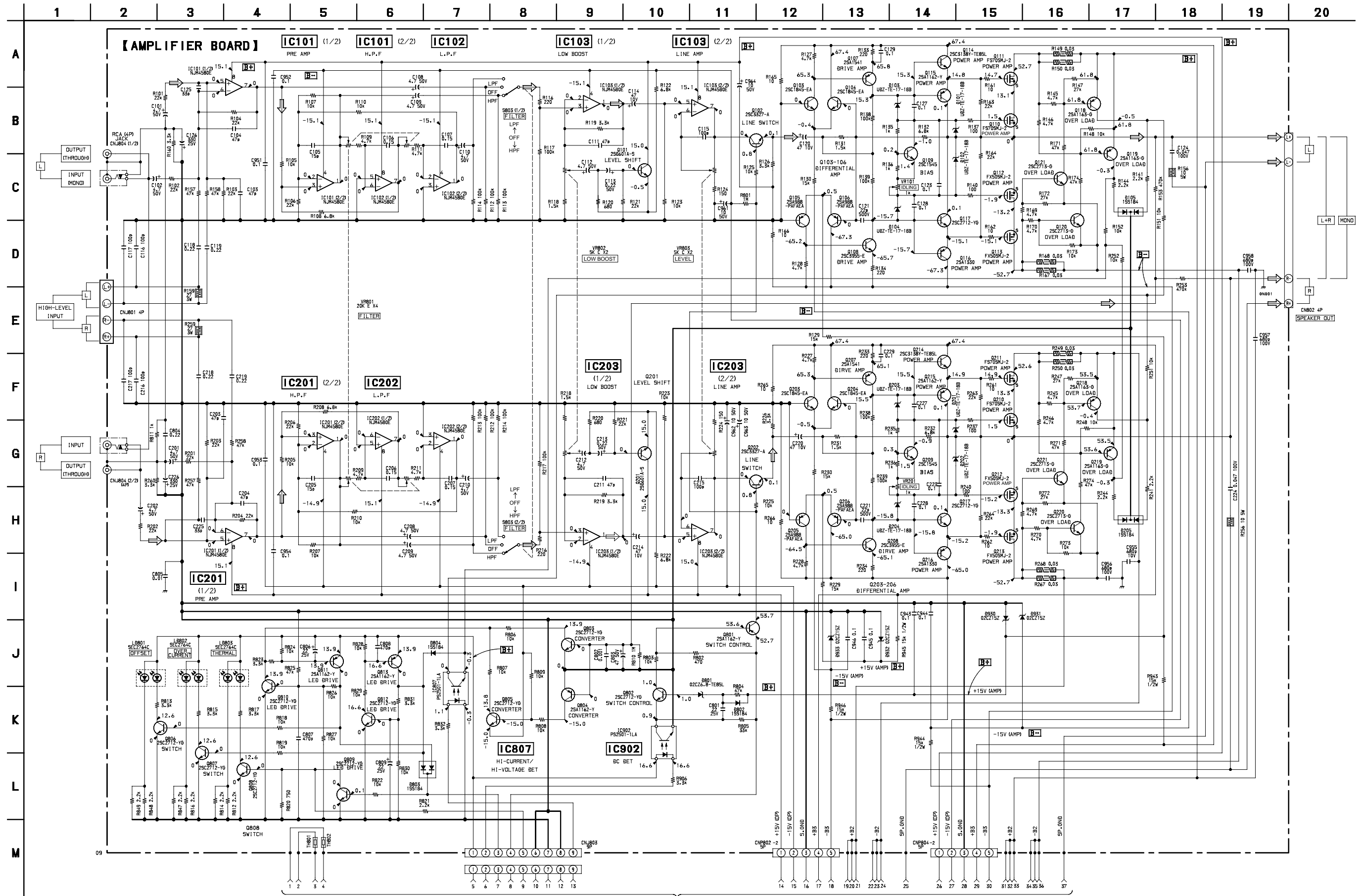



5-4. PRINTED WIRING BOARD – POWER SECTION –

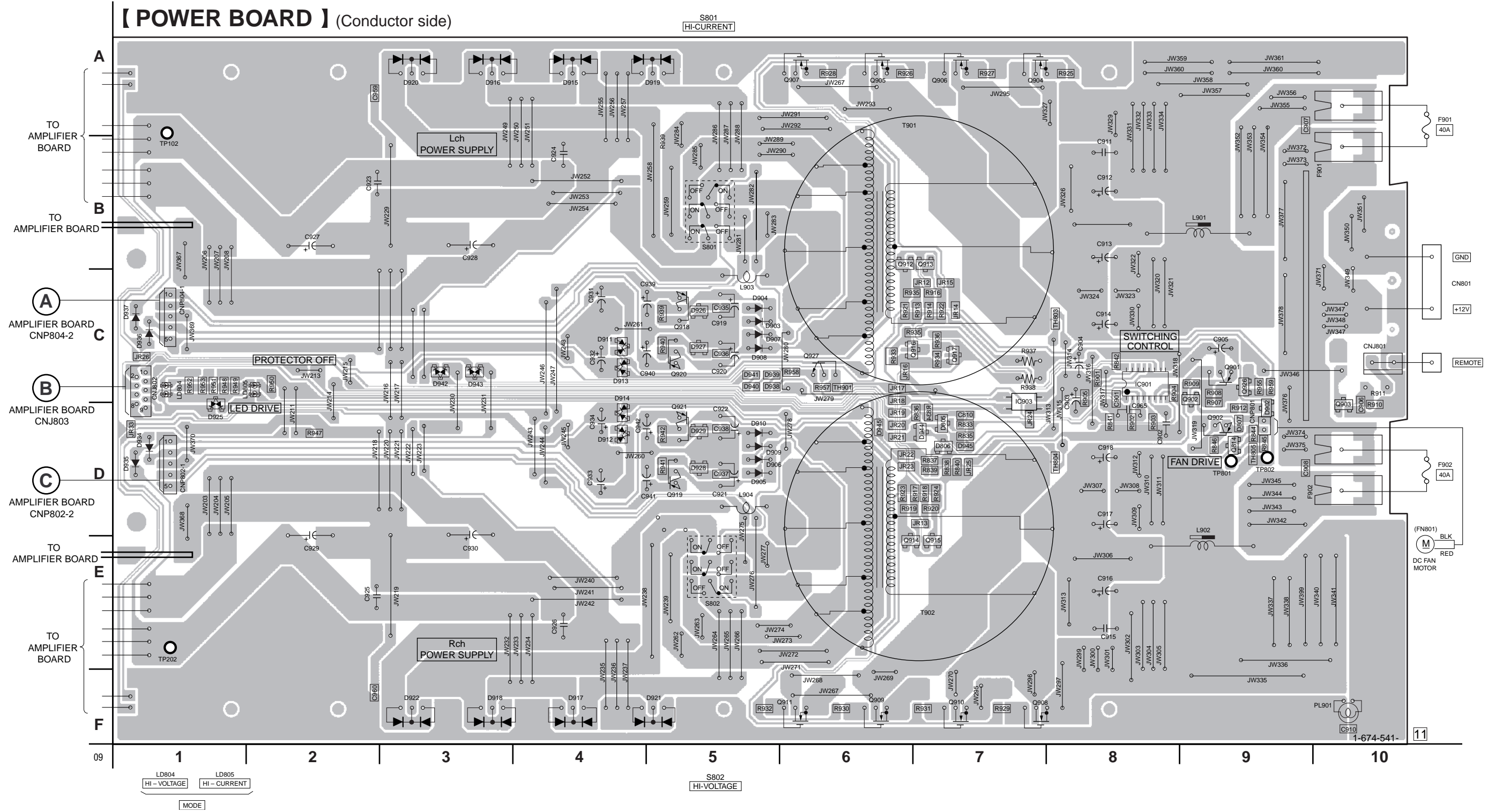

• Semiconductor Location

Ref. No.	Location	Ref. No.	Location	Ref. No.	Location	Ref. No.	Location	Ref. No.	Location	Ref. No.	Location	Ref. No.	Location	Ref. No.	Location
D805	D-7	D907	C-5	D916	A-3	D927	C-5	D940	C-5	Q814	D-9	Q908	F-7	Q917	C-7
D806	D-7	D908	C-5	D917	F-4	D928	D-5	D941	C-5	Q815	D-9	Q909	F-6	Q918	C-5
D807	D-9	D909	D-5	D918	F-3	D929	D-5	D942	C-3	Q901	C-9	Q910	F-7	Q919	D-5
D901	C-9	D910	D-5	D919	A-5	D934	D-1	D943	C-3	Q902	C-9	Q911	F-6	Q920	C-5
D902	D-9	D911	C-4	D920	A-3	D935	D-1	D944	D-7	Q903	D-10	Q912	B-6	Q921	D-5
D903	C-5	D912	D-4	D921	F-5	D936	C-1	D945	D-6	Q904	A-7	Q913	B-7	Q926	C-9
D904	C-5	D913	C-4	D922	F-3	D937	C-1			Q905	A-6	Q914	E-7	Q927	C-6
D905	D-5	D914	D-4	D925	C-1	D938	C-5	IC901	C-8	Q906	A-7	Q915	E-7		
D906	D-5	D915	A-4	D926	C-5	D939	C-5	IC903	C-7	Q907	A-6	Q916	C-7		

5-5. SCHEMATIC DIAGRAM – POWER SECTION –  
 • See page 10 for IC Block Diagrams.

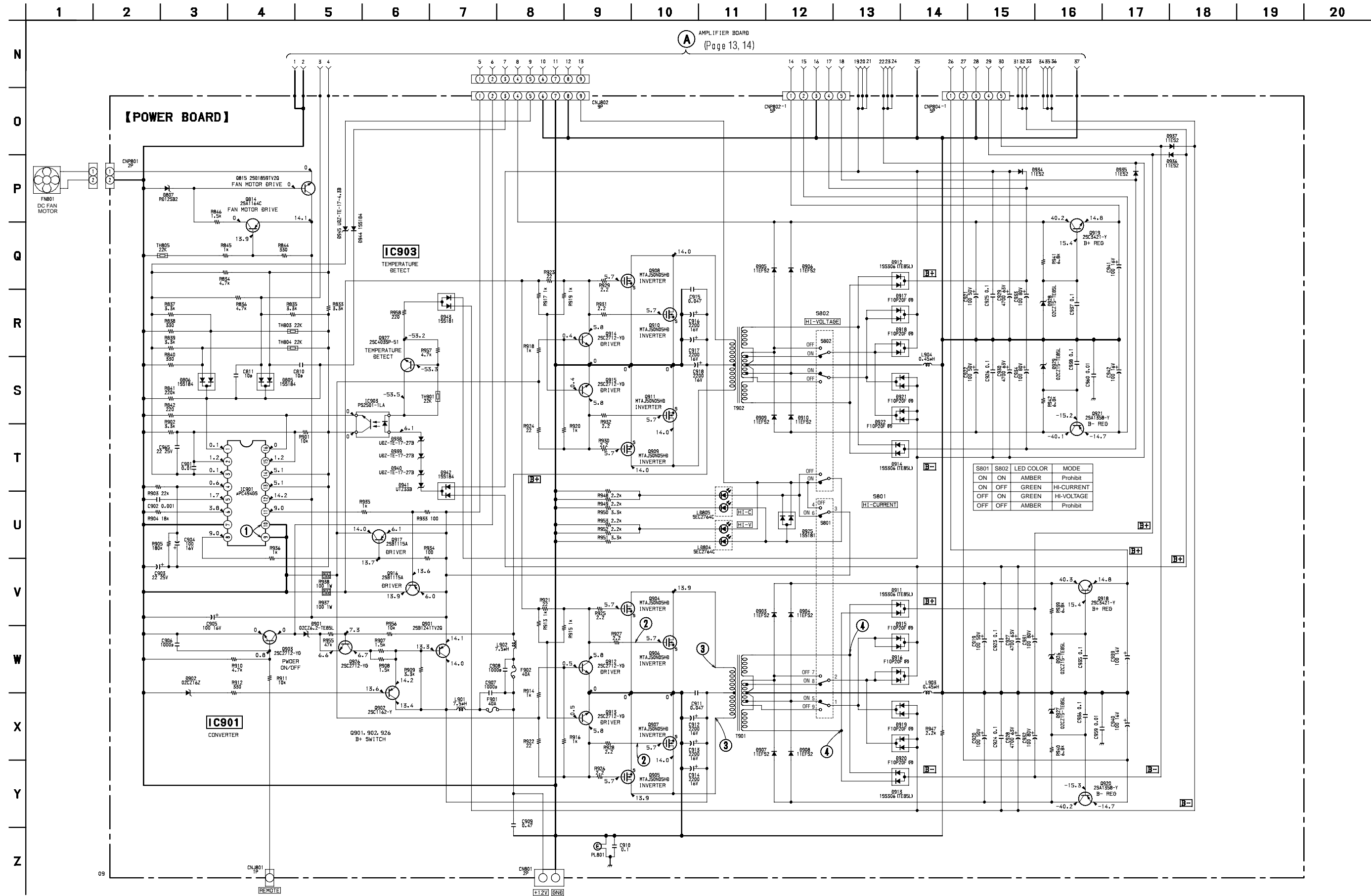

## SECTION 6 EXPLODED VIEWS

**NOTE:**

- Items marked "\*" are not stocked since they are seldom required for routine service. Some delay should be anticipated when ordering these items.
- The mechanical parts with no reference number in the exploded views are not supplied.

- Hardware (# mark) list and accessories and packing materials are given in the last of this parts list.

### (1) BOTTOM PLATE AND PANEL (FRONT/REAR) SECTION

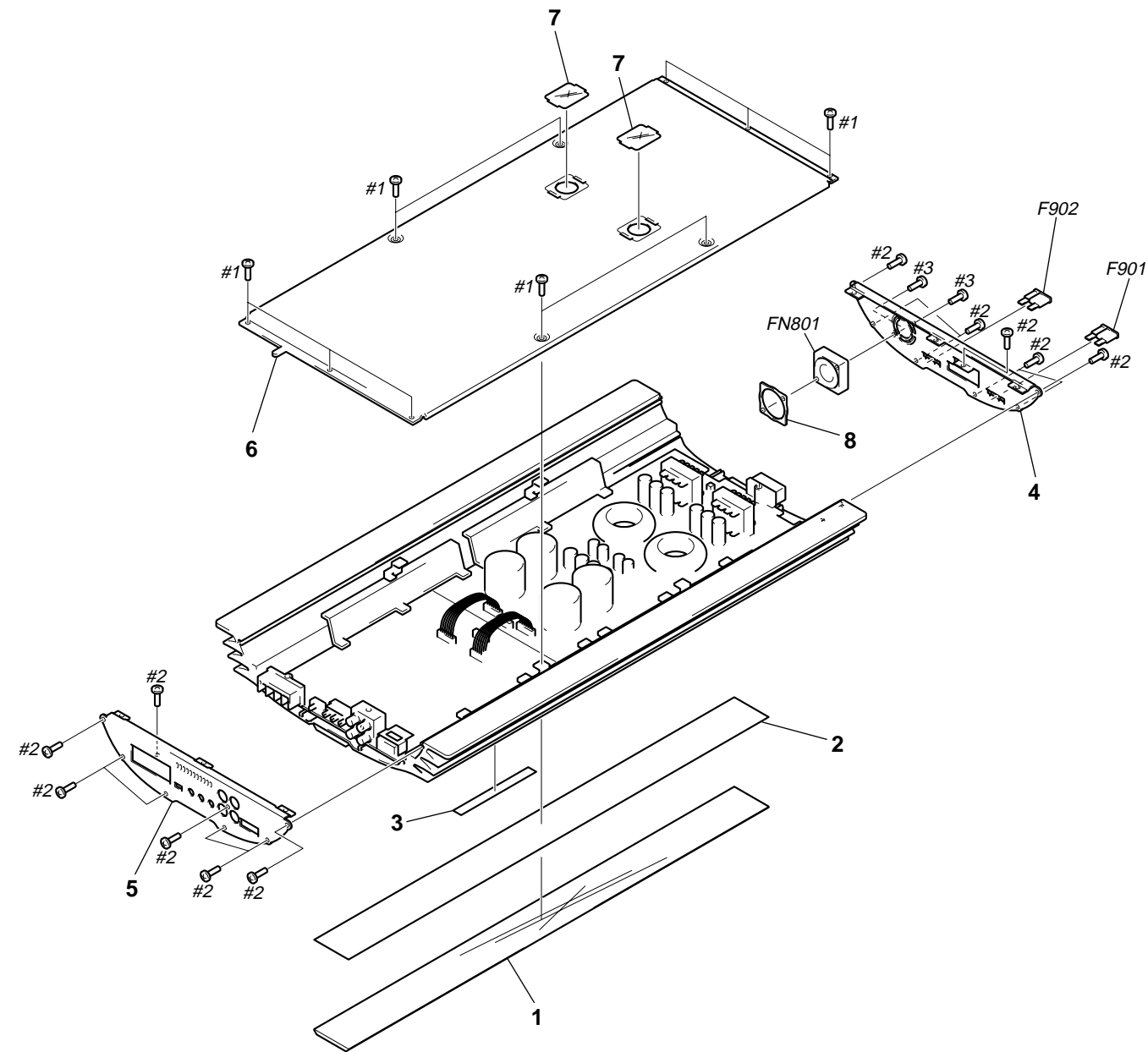

Ref. No.	Part No.	Description	Remark	Ref. No.	Part No.	Description	Remark
1	3-034-552-01	PLATE, ORNAMENTAL		7	3-023-803-01	COVER	
2	3-035-494-01	SHEET (DOUBLE-FACE)		* 8	3-023-795-01	BRACKET (FAN)	
* 3	3-023-804-01	SHEET, DIFFUSION		F901	1-533-743-11	FUSE (BLADE TYPE) (AUTO FUSE) (40A)	
* 4	3-035-489-01	PANEL (FRONT)		F902	1-533-743-11	FUSE (BLADE TYPE) (AUTO FUSE) (40A)	
* 5	3-035-490-01	PANEL (REAR)					
* 6	3-035-491-01	PLATE, BOTTOM		FN801	1-763-107-11	MOTOR, FAN	

### (2) AMP/POWER BOARD SECTION

**NOTE:**

- F901, F902 AND FN801 are including into the AMP/Power board.

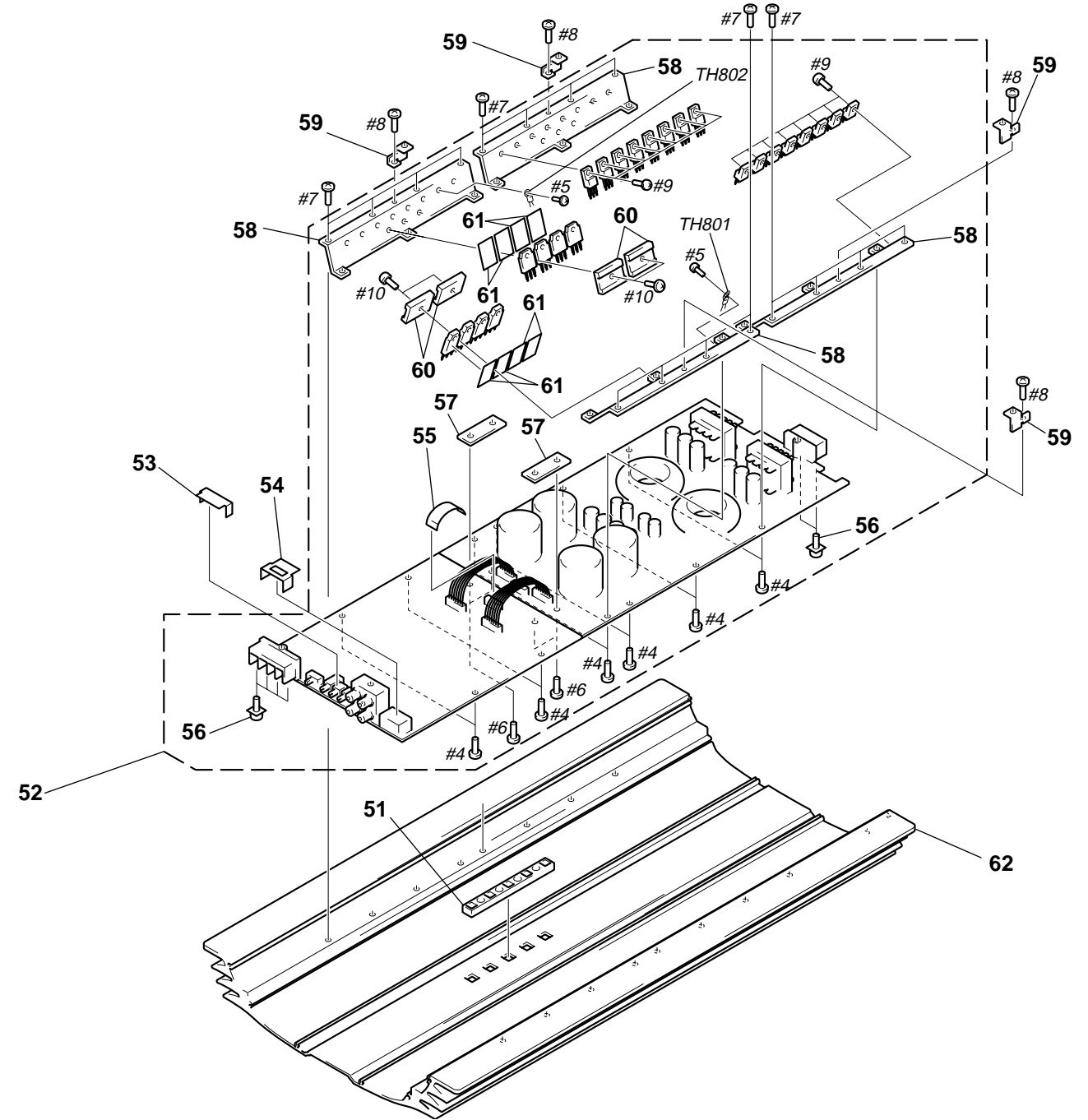

Ref. No.	Part No.	Description	Remark	Ref. No.	Part No.	Description	Remark
51	3-035-483-01	RUBBER, LIGHT INTERCEPTION		* 58	3-035-493-01	HEAT SINK (SUB)	
* 52	A-3294-710-A	AMP/POWER BOARD, COMPLETE		* 59	3-023-800-01	BRACKET (BOTTOM PLATE)	
* 53	3-023-798-01	BRACKET (VR)		60	3-037-684-01	PLATE, RETAINER	
* 54	3-023-799-01	BRACKET (HIGH LEVEL)					
55	1-575-388-11	CABLE, FLAT 9P		61	3-025-081-01	SHEET (INSULATING)	
				* 62	3-035-492-01	HEAT SINK	
56	3-912-431-01	M4X8 (P)		TH801	1-809-664-51	THERMISTOR, POSITIVE	
* 57	3-035-968-01	BRACKET (CHASSIS)		TH802	1-809-664-51	THERMISTOR, POSITIVE	

# SECTION 7 ELECTRICAL PARTS LIST

AMPLIFIER

Note:

When indicating parts by reference number, please include the board name.

- Due to standardization, replacements in the parts list may be different from the parts specified in the diagrams or the components used on the set.
- -XX, -X mean standardized parts, so they may have some difference from the original one.

- Items marked “\*\*” are not stocked since they are seldom required for routine service. Some delay should be anticipated when ordering these items.
- RESISTORS  
All resistors are in ohms  
METAL: Metal-film resistor  
METAL OXIDE: Metal Oxide-film resistor  
F : nonflammable

- SEMICONDUCTORS  
In each case, u:  $\mu$ , for example:  
uA...:  $\mu$  A..., uPA...:  $\mu$  PA..., uPB...:  $\mu$  PB...,  
uPC...:  $\mu$  PC..., uPD...:  $\mu$  PD...
- CAPACITORS  
uF :  $\mu$  F
- COILS  
uH :  $\mu$  H

Ref. No.	Part No.	Description	Remark	Ref. No.	Part No.	Description	Remark
*	A-3294-710-A	AMP/POWER BOARD, COMPLETE (Including AMPLIFIER BOARD and POWER BOARD)		C204	1-163-243-11	CERAMIC CHIP 47PF	5% 50V
				C205	1-163-231-11	CERAMIC CHIP 15PF	5% 50V
	1-575-388-11	CABLE, FLAT 9P		C206	1-130-497-00	MYLAR 0.15uF	5% 50V
*	3-035-968-01	BRACKET (CHASSIS)		C207	1-130-497-00	MYLAR 0.15uF	5% 50V
*	3-035-493-01	HEAT SINK (SUB)		C208	1-126-047-11	ELECT 4.7uF	20% 50V
	3-037-684-01	PLATE, RETAINER		C209	1-126-047-11	ELECT 4.7uF	20% 50V
	3-025-081-01	SHEET (INSULATING)		C210	1-126-047-11	ELECT 4.7uF	20% 50V
	7-685-646-79	+P 3x8 TYPE2 N-S		C211	1-163-243-11	CERAMIC CHIP 47PF	5% 50V
	7-685-144-11	+P 3x5 TYPE2 N-S		C212	1-126-047-11	ELECT 4.7uF	20% 50V
	7-682-546-09	SCREW +B 3x5		C213	1-126-957-11	ELECT 0.22uF	20% 50V
	7-682-949-01	+PSW 3x10		C214	1-126-022-11	ELECT 47uF	20% 10V
	7-685-649-79	+P 3x14 TYPE2 N-S		C215	1-163-251-11	CERAMIC CHIP 100PF	5% 50V
		AMPLIFIER BOARD *****		C216	1-163-251-11	CERAMIC CHIP 100PF	5% 50V
		< CAPACITOR >		C217	1-163-251-11	CERAMIC CHIP 100PF	5% 50V
C101	1-126-047-11	ELECT 4.7uF	20% 50V	C218	1-164-222-11	CERAMIC CHIP 0.22uF	25V
C102	1-126-047-11	ELECT 4.7uF	20% 50V	C219	1-164-222-11	CERAMIC CHIP 0.22uF	25V
C103	1-163-243-11	CERAMIC CHIP 47PF	5% 50V	C220	1-126-022-11	ELECT 47uF	20% 10V
C104	1-163-243-11	CERAMIC CHIP 47PF	5% 50V	C221	1-107-597-11	CERAMIC 22PF	5% 500V
C105	1-163-231-11	CERAMIC CHIP 15PF	5% 50V	C223	1-165-319-11	CERAMIC CHIP 0.1uF	50V
C106	1-130-497-00	MYLAR 0.15uF	5% 50V	C224	1-137-397-11	FILM 0.047uF	5% 100V
C107	1-130-497-00	MYLAR 0.15uF	5% 50V	C225	1-163-239-11	CERAMIC CHIP 33PF	5% 50V
C108	1-126-047-11	ELECT 4.7uF	20% 50V	C226	1-126-940-11	ELECT 330uF	20% 25V
C109	1-126-047-11	ELECT 4.7uF	20% 50V	C227	1-165-319-11	CERAMIC CHIP 0.1uF	50V
C110	1-126-047-11	ELECT 4.7uF	20% 50V	C228	1-165-319-11	CERAMIC CHIP 0.1uF	50V
C111	1-163-243-11	CERAMIC CHIP 47PF	5% 50V	C229	1-136-165-00	FILM 0.1uF	5% 50V
C112	1-126-047-11	ELECT 4.7uF	20% 50V	C230	1-131-596-11	CERAMIC CHIP 4700PF	50V
C113	1-126-957-11	ELECT 0.22uF	20% 50V	C231	1-131-596-11	CERAMIC CHIP 4700PF	50V
C114	1-126-022-11	ELECT 47uF	20% 10V	C801	1-124-282-00	ELECT 22uF	20% 25V
C115	1-163-251-11	CERAMIC CHIP 100PF	5% 50V	C802	1-163-009-11	CERAMIC CHIP 0.001uF	10% 50V
C116	1-163-251-11	CERAMIC CHIP 100PF	5% 50V	C803	1-126-967-11	ELECT 47uF	20% 50V
C117	1-163-251-11	CERAMIC CHIP 100PF	5% 50V	C804	1-164-222-11	CERAMIC CHIP 0.22uF	25V
C118	1-164-222-11	CERAMIC CHIP 0.22uF	25V	C805	1-163-021-11	CERAMIC CHIP 0.01uF	10% 50V
C119	1-164-222-11	CERAMIC CHIP 0.22uF	25V	C806	1-128-551-11	ELECT 22uF	20% 25V
C120	1-126-022-11	ELECT 47uF	20% 10V	C807	1-163-133-00	CERAMIC CHIP 470PF	5% 50V
C121	1-107-597-11	CERAMIC 22PF	5% 500V	C808	1-163-133-00	CERAMIC CHIP 470PF	5% 50V
C122	1-165-319-11	CERAMIC CHIP 0.1uF	50V	C809	1-128-551-11	ELECT 22uF	20% 25V
C123	1-165-319-11	CERAMIC CHIP 0.1uF	50V	C943	1-165-319-11	CERAMIC CHIP 0.1uF	50V
C124	1-137-397-11	FILM 0.047uF	5% 100V	C944	1-165-319-11	CERAMIC CHIP 0.1uF	50V
C125	1-163-239-11	CERAMIC CHIP 33PF	5% 50V	C945	1-165-319-11	CERAMIC CHIP 0.1uF	50V
C126	1-126-940-11	ELECT 330uF	20% 25V	C946	1-165-319-11	CERAMIC CHIP 0.1uF	50V
C127	1-165-319-11	CERAMIC CHIP 0.1uF	50V	C951	1-165-319-11	CERAMIC CHIP 0.1uF	50V
C128	1-165-319-11	CERAMIC CHIP 0.1uF	50V	C952	1-165-319-11	CERAMIC CHIP 0.1uF	50V
C129	1-136-165-00	FILM 0.1uF	5% 50V	C953	1-165-319-11	CERAMIC CHIP 0.1uF	50V
C130	1-131-596-11	CERAMIC CHIP 4700PF	50V	C954	1-165-319-11	CERAMIC CHIP 0.1uF	50V
C131	1-131-596-11	CERAMIC CHIP 4700PF	50V	C955	1-162-542-11	CERAMIC CHIP 680PF	5% 100V
C201	1-126-047-11	ELECT 4.7uF	20% 50V	C956	1-162-542-11	CERAMIC CHIP 680PF	5% 100V
C202	1-126-047-11	ELECT 4.7uF	20% 50V	C957	1-162-542-11	CERAMIC CHIP 680PF	5% 100V
C203	1-163-243-11	CERAMIC CHIP 47PF	5% 50V	C958	1-162-542-11	CERAMIC CHIP 680PF	5% 100V
				C961	1-126-059-11	ELECT 10uF	20% 50V
				C962	1-126-059-11	ELECT 10uF	20% 50V



# AMPLIFIER

Ref. No.	Part No.	Description	Remark	Ref. No.	Part No.	Description	Remark
C963	1-126-059-11	ELECT	10uF 20% 50V	Q113	8-729-049-53	TRANSISTOR	FX50SMJ-2
C964	1-126-059-11	ELECT	10uF 20% 50V	Q114	8-729-205-76	TRANSISTOR	2SC3138Y-TE85L
< CONNECTOR >				Q115	8-729-216-21	TRANSISTOR	2SA1162-Y
CN802	1-537-478-21	TERMINAL BOARD (4P) (SPEAKER OUT)		Q116	8-729-105-08	TRANSISTOR	2SA1330
CNJ801	1-784-904-11	CONNECTOR 4P (HIGH LEVEL INPUT)		Q117	8-729-230-49	TRANSISTOR	2SC2712-YG
CNJ803	1-766-902-11	CONNECTOR, FFC/FPC (ZIF) 9P		Q118	8-729-216-31	TRANSISTOR	2SA1163-G
CNJ804	1-779-078-51	JACK, PIN 4P (INPUT (MONO) OUTPUT (THROUGH))		Q119	8-729-216-31	TRANSISTOR	2SA1163-G
< DIODE >				Q120	8-729-271-31	TRANSISTOR	2SC2713-G
D101	8-719-056-93	DIODE	UDZ-TE-17-18B	Q121	8-729-271-31	TRANSISTOR	2SC2713-G
D102	8-719-056-93	DIODE	UDZ-TE-17-18B	Q201	8-729-422-29	TRANSISTOR	2SD601A-S
D103	8-719-977-40	DIODE	UDZ-TE-17-13B	Q202	8-729-203-48	TRANSISTOR	2SC3327-A
D104	8-719-977-40	DIODE	UDZ-TE-17-13B	Q203	8-729-184-53	TRANSISTOR	2SC1845-EA
D105	8-719-801-78	DIODE	1SS184	Q204	8-729-184-53	TRANSISTOR	2SC1845-EA
D201	8-719-056-93	DIODE	UDZ-TE-17-18B	Q205	8-729-140-82	TRANSISTOR	2SA988-PAFAEA
D202	8-719-056-93	DIODE	UDZ-TE-17-18B	Q206	8-729-140-82	TRANSISTOR	2SA988-PAFAEA
D203	8-719-977-40	DIODE	UDZ-TE-17-13B	Q207	8-729-822-80	TRANSISTOR	2SA1541
D204	8-719-977-40	DIODE	UDZ-TE-17-13B	Q208	8-729-822-47	TRANSISTOR	2SC3955-E
D205	8-719-801-78	DIODE	1SS184	Q209	8-729-954-51	TRANSISTOR	2SC1545
D801	8-719-025-34	DIODE	02CZ6.8-TE85L	Q210	8-729-049-52	TRANSISTOR	FS70SMJ-2
D802	8-719-801-78	DIODE	1SS184	Q211	8-729-049-52	TRANSISTOR	FS70SMJ-2
D803	8-719-801-78	DIODE	1SS184	Q212	8-729-049-53	TRANSISTOR	FX50SMJ-2
D804	8-719-801-78	DIODE	1SS184	Q213	8-729-049-53	TRANSISTOR	FX50SMJ-2
D930	8-719-025-49	DIODE	02CZ15-TE85L	Q214	8-729-205-76	TRANSISTOR	2SC3138Y-TE85L
D931	8-719-025-49	DIODE	02CZ15-TE85L	Q215	8-729-216-21	TRANSISTOR	2SA1162-Y
D932	8-719-025-49	DIODE	02CZ15-TE85L	Q216	8-729-105-08	TRANSISTOR	2SA1330
D933	8-719-025-49	DIODE	02CZ15-TE85L	Q217	8-729-230-49	TRANSISTOR	2SC2712-YG
< IC >				Q218	8-729-216-31	TRANSISTOR	2SA1163-G
IC101	8-759-711-82	IC	NJM4580E	Q219	8-729-216-31	TRANSISTOR	2SA1163-G
IC102	8-759-711-82	IC	NJM4580E	Q220	8-729-271-31	TRANSISTOR	2SC2713-G
IC103	8-759-711-82	IC	NJM4580E	Q221	8-729-271-31	TRANSISTOR	2SC2713-G
IC201	8-759-711-82	IC	NJM4580E	Q801	8-729-216-21	TRANSISTOR	2SA1162-Y
IC202	8-759-711-82	IC	NJM4580E	Q802	8-729-230-49	TRANSISTOR	2SC2712-YG
IC203	8-759-711-82	IC	NJM4580E	Q803	8-729-230-49	TRANSISTOR	2SC2712-YG
IC807	8-719-156-73	PHOTO COUPLER	PS2501-1LA	Q804	8-729-216-21	TRANSISTOR	2SA1162-Y
IC902	8-719-156-73	PHOTO COUPLER	PS2501-1LA	Q805	8-729-230-49	TRANSISTOR	2SC2712-YG
< DIODE >				Q806	8-729-230-49	TRANSISTOR	2SC2712-YG
LD801	8-719-070-01	DIODE	SEC2764C (OFFSET)	Q807	8-729-230-49	TRANSISTOR	2SC2712-YG
LD802	8-719-070-01	DIODE	SEC2764C (OVER CURRENT)	Q808	8-729-230-49	TRANSISTOR	2SC2712-YG
LD803	8-719-070-01	DIODE	SEC2764C (THERMAL)	Q809	8-729-230-49	TRANSISTOR	2SC2712-YG
< TRANSISTOR >				Q810	8-729-230-49	TRANSISTOR	2SC2712-YG
Q101	8-729-422-29	TRANSISTOR	2SD601A-S	Q811	8-729-216-21	TRANSISTOR	2SA1162-Y
Q102	8-729-203-48	TRANSISTOR	2SC3327-A	Q812	8-729-230-49	TRANSISTOR	2SC2712-YG
Q103	8-729-184-53	TRANSISTOR	2SC1845-EA	Q813	8-729-216-21	TRANSISTOR	2SA1162-Y
Q104	8-729-184-53	TRANSISTOR	2SC1845-EA	< RESISTOR >			
Q105	8-729-140-82	TRANSISTOR	2SA988-PAFAEA	R101	1-208-518-61	RES,CHIP	22K 2% 1/10W
Q106	8-729-140-82	TRANSISTOR	2SA988-PAFAEA	R102	1-208-518-61	RES,CHIP	22K 2% 1/10W
Q107	8-729-822-80	TRANSISTOR	2SA1541	R103	1-208-518-61	RES,CHIP	22K 2% 1/10W
Q108	8-729-822-47	TRANSISTOR	2SC3955-E	R104	1-208-518-61	RES,CHIP	22K 2% 1/10W
Q109	8-729-954-51	TRANSISTOR	2SC1545	R105	1-208-806-11	RES,CHIP	10K 2% 1/10W
Q110	8-729-049-52	TRANSISTOR	FS70SMJ-2	R106	1-208-518-61	RES,CHIP	22K 2% 1/10W
Q111	8-729-049-52	TRANSISTOR	FS70SMJ-2	R107	1-208-806-11	RES,CHIP	10K 2% 1/10W
Q112	8-729-049-53	TRANSISTOR	FX50SMJ-2	R108	1-216-671-11	METAL CHIP	6.8K 0.5% 1/10W
				R109	1-216-667-11	METAL CHIP	4.7K 0.5% 1/10W
				R110	1-208-806-11	RES,CHIP	10K 2% 1/10W
				R111	1-216-667-11	METAL CHIP	4.7K 0.5% 1/10W
				R112	1-208-534-61	RES,CHIP	100K 2% 1/10W
				R113	1-208-534-61	RES,CHIP	100K 2% 1/10W

**AMPLIFIER**

Ref. No.	Part No.	Description			Remark	Ref. No.	Part No.	Description			Remark
R114	1-208-534-61	RES,CHIP	100K	2%	1/10W	R202	1-208-518-61	RES,CHIP	22K	2%	1/10W
R116	1-216-635-11	METAL CHIP	220	0.5%	1/10W	R203	1-208-518-61	RES,CHIP	22K	2%	1/10W
R117	1-208-534-61	RES,CHIP	100K	2%	1/10W	R204	1-208-518-61	RES,CHIP	22K	2%	1/10W
R118	1-208-441-61	RES,CHIP	1.5K	2%	1/10W	R205	1-208-806-11	RES,CHIP	10K	2%	1/10W
R119	1-216-663-11	METAL CHIP	3.3K	0.5%	1/10W	R206	1-208-518-61	RES,CHIP	22K	2%	1/10W
R120	1-216-647-11	METAL CHIP	680	0.5%	1/10W	R207	1-208-806-11	RES,CHIP	10K	2%	1/10W
R121	1-208-518-61	RES,CHIP	22K	2%	1/10W	R208	1-216-671-11	METAL CHIP	6.8K	0.5%	1/10W
R122	1-208-506-11	RES,CHIP	6.8K	2%	1/8W	R209	1-216-667-11	METAL CHIP	4.7K	0.5%	1/10W
R123	1-208-806-11	RES,CHIP	10K	2%	1/10W	R210	1-208-806-11	RES,CHIP	10K	2%	1/10W
R124	1-216-631-11	METAL CHIP	150	0.5%	1/10W	R211	1-216-667-11	METAL CHIP	4.7K	0.5%	1/10W
R125	1-208-510-61	RES,CHIP	10K	2%	1/8W	R212	1-208-534-61	RES,CHIP	100K	2%	1/10W
R126	1-216-663-11	METAL CHIP	3.3K	0.5%	1/10W	R213	1-208-534-61	RES,CHIP	100K	2%	1/10W
R127	1-216-667-11	METAL CHIP	4.7K	0.5%	1/10W	R214	1-208-534-61	RES,CHIP	100K	2%	1/10W
R128	1-216-667-11	METAL CHIP	4.7K	0.5%	1/10W	R216	1-216-635-11	METAL CHIP	220	0.5%	1/10W
R129	1-208-810-11	RES,CHIP	15K	2%	1/10W	R217	1-208-534-61	RES,CHIP	100K	2%	1/10W
R130	1-208-810-11	RES,CHIP	15K	2%	1/10W	R218	1-208-441-61	RES,CHIP	1.5K	2%	1/10W
R131	1-249-556-11	CARBON	1.5K	5%	1/4W	R219	1-216-663-11	METAL CHIP	3.3K	0.5%	1/10W
R132	1-259-324-11	CARBON	6.8K	5%	1/2W	R220	1-216-647-11	METAL CHIP	680	0.5%	1/10W
R133	1-216-635-11	METAL CHIP	220	0.5%	1/10W	R221	1-208-518-61	RES,CHIP	22K	2%	1/10W
R134	1-216-635-11	METAL CHIP	220	0.5%	1/10W	R222	1-208-506-11	RES,CHIP	6.8K	2%	1/8W
R135	1-216-651-11	METAL CHIP	1K	0.5%	1/10W	R223	1-208-806-11	RES,CHIP	10K	2%	1/10W
R136	1-216-651-11	METAL CHIP	1K	0.5%	1/10W	R224	1-216-631-11	METAL CHIP	150	0.5%	1/10W
R137	1-208-413-11	RES,CHIP	100	2%	1/8W	R225	1-208-510-61	RES,CHIP	10K	2%	1/8W
R138	1-208-534-61	RES,CHIP	100K	2%	1/10W	R226	1-216-663-11	METAL CHIP	3.3K	0.5%	1/10W
R139	1-208-534-61	RES,CHIP	100K	2%	1/10W	R227	1-216-667-11	METAL CHIP	4.7K	0.5%	1/10W
R140	1-208-413-11	RES,CHIP	100	2%	1/8W	R228	1-216-667-11	METAL CHIP	4.7K	0.5%	1/10W
R141	1-216-206-00	RES,CHIP	2.2K	2%	1/8W	R229	1-208-810-11	RES,CHIP	15K	2%	1/10W
R144	1-216-206-00	RES,CHIP	2.2K	2%	1/8W	R230	1-208-810-11	RES,CHIP	15K	2%	1/10W
R145	1-216-667-11	METAL CHIP	4.7K	0.5%	1/10W	R231	1-249-556-11	CARBON	1.5K	5%	1/4W
R146	1-216-667-11	METAL CHIP	4.7K	0.5%	1/10W	R232	1-259-324-11	CARBON	6.8K	5%	1/2W
R147	1-216-685-11	METAL CHIP	27K	0.5%	1/10W	R233	1-216-635-11	METAL CHIP	220	0.5%	1/10W
R148	1-208-806-11	RES,CHIP	10K	2%	1/10W	R234	1-216-635-11	METAL CHIP	220	0.5%	1/10W
R149	1-240-882-11	REGISTER	0.03		5W	R235	1-216-651-11	METAL CHIP	1K	0.5%	1/10W
R150	1-240-882-11	REGISTER	0.03		5W	R236	1-216-651-11	METAL CHIP	1K	0.5%	1/10W
R151	1-208-806-11	RES,CHIP	10K	2%	1/10W	R237	1-208-413-11	RES,CHIP	100	2%	1/8W
R152	1-208-806-11	RES,CHIP	10K	2%	1/10W	R238	1-208-534-61	RES,CHIP	100K	2%	1/10W
R153	1-208-550-61	RES,CHIP	470K	2%	1/10W	R239	1-208-534-61	RES,CHIP	100K	2%	1/10W
R156	1-217-784-11	FUSIBLE	10	5%	5W F	R240	1-208-413-11	RES,CHIP	100	2%	1/8W
R157	1-208-526-61	RES,CHIP	47K	2%	1/10W	R241	1-216-206-00	RES,CHIP	2.2K	2%	1/8W
R158	1-208-526-61	RES,CHIP	47K	2%	1/10W	R244	1-216-206-00	RES,CHIP	2.2K	2%	1/8W
R159	1-216-471-11	METAL OXIDE	27	5%	3W F	R245	1-216-667-11	METAL CHIP	4.7K	0.5%	1/10W
R160	1-216-210-00	RES,CHIP	3.3K	2%	1/8W	R246	1-216-667-11	METAL CHIP	4.7K	0.5%	1/10W
R161	1-216-150-00	RES,CHIP	10	2%	1/8W	R247	1-216-685-11	METAL CHIP	27K	0.5%	1/10W
R162	1-216-150-00	RES,CHIP	10	2%	1/8W	R248	1-208-806-11	RES,CHIP	10K	2%	1/10W
R163	1-216-230-00	RES,CHIP	22K	2%	1/8W	R249	1-240-882-11	REGISTER	0.03		5W
R164	1-216-230-00	RES,CHIP	22K	2%	1/8W	R250	1-240-882-11	REGISTER	0.03		5W
R165	1-216-603-11	METAL CHIP	10	0.5%	1/10W	R251	1-208-806-11	RES,CHIP	10K	2%	1/10W
R166	1-216-603-11	METAL CHIP	10	0.5%	1/10W	R252	1-208-806-11	RES,CHIP	10K	2%	1/10W
R167	1-240-882-11	REGISTER	0.03		5W	R253	1-208-550-61	RES,CHIP	470K	2%	1/10W
R168	1-240-882-11	REGISTER	0.03		5W	R256	1-217-784-11	FUSIBLE	10	5%	5W F
R169	1-216-667-11	METAL CHIP	4.7K	0.5%	1/10W	R257	1-208-526-61	RES,CHIP	47K	2%	1/10W
R170	1-216-667-11	METAL CHIP	4.7K	0.5%	1/10W	R258	1-208-526-61	RES,CHIP	47K	2%	1/10W
R171	1-216-238-00	RES,CHIP	47K	2%	1/8W	R259	1-216-471-11	METAL OXIDE	27	5%	3W F
R172	1-216-685-11	METAL CHIP	27K	0.5%	1/10W	R260	1-216-210-00	RES,CHIP	3.3K	2%	1/8W
R173	1-208-806-11	RES,CHIP	10K	2%	1/10W	R261	1-216-150-00	RES,CHIP	10	2%	1/8W
R174	1-216-238-00	RES,CHIP	47K	2%	1/8W	R262	1-216-150-00	RES,CHIP	10	2%	1/8W
R201	1-208-518-61	RES,CHIP	22K	2%	1/10W	R263	1-216-230-00	RES,CHIP	22K	2%	1/8W
						R264	1-216-230-00	RES,CHIP	22K	2%	1/8W

**AMPLIFIER**

**POWER**

Ref. No.	Part No.	Description	Remark
R265	1-216-603-11	METAL CHIP	10 0.5% 1/10W
R266	1-216-603-11	METAL CHIP	10 0.5% 1/10W
R267	1-240-882-11	REGISTER	0.03 5W
R268	1-240-882-11	REGISTER	0.03 5W
R269	1-216-667-11	METAL CHIP	4.7K 0.5% 1/10W
R270	1-216-667-11	METAL CHIP	4.7K 0.5% 1/10W
R271	1-216-238-00	RES,CHIP	47K 2% 1/8W
R272	1-216-685-11	METAL CHIP	27K 0.5% 1/10W
R273	1-208-806-11	RES,CHIP	10K 2% 1/10W
R274	1-216-238-00	RES,CHIP	47K 2% 1/8W
R801	1-208-558-61	RES,CHIP	1M 2% 1/10W
R802	1-208-774-11	RES,CHIP	470 2% 1/10W
R803	1-208-510-61	RES,CHIP	10K 2% 1/8W
R804	1-208-526-61	RES,CHIP	47K 2% 1/10W
R805	1-208-522-61	RES,CHIP	33K 2% 1/10W
R806	1-208-806-11	RES,CHIP	10K 2% 1/10W
R807	1-208-806-11	RES,CHIP	10K 2% 1/10W
R808	1-208-806-11	RES,CHIP	10K 2% 1/10W
R809	1-208-806-11	RES,CHIP	10K 2% 1/10W
R810	1-208-558-61	RES,CHIP	1M 2% 1/10W
R811	1-208-486-61	RES,CHIP	1K 2% 1/8W
R812	1-216-206-00	RES,CHIP	2.2K 2% 1/8W
R813	1-216-210-00	RES,CHIP	3.3K 2% 1/8W
R814	1-216-206-00	RES,CHIP	2.2K 2% 1/8W
R815	1-216-210-00	RES,CHIP	3.3K 2% 1/8W
R816	1-216-206-00	RES,CHIP	2.2K 2% 1/8W
R817	1-216-210-00	RES,CHIP	3.3K 2% 1/8W
R818	1-208-806-11	RES,CHIP	10K 2% 1/10W
R819	1-208-806-11	RES,CHIP	10K 2% 1/10W
R820	1-216-648-11	METAL CHIP	750 0.5% 1/10W
R821	1-216-659-11	METAL CHIP	2.2K 0.5% 1/10W
R822	1-208-806-11	RES,CHIP	10K 2% 1/10W
R823	1-216-210-00	RES,CHIP	3.3K 2% 1/8W
R824	1-208-806-11	RES,CHIP	10K 2% 1/10W
R825	1-216-238-00	RES,CHIP	47K 2% 1/8W
R826	1-208-806-11	RES,CHIP	10K 2% 1/10W
R827	1-208-806-11	RES,CHIP	10K 2% 1/10W
R828	1-208-806-11	RES,CHIP	10K 2% 1/10W
R829	1-208-510-61	RES,CHIP	10K 2% 1/8W
R830	1-208-806-11	RES,CHIP	10K 2% 1/10W
R831	1-216-663-11	METAL CHIP	3.3K 0.5% 1/10W
R832	1-216-210-00	RES,CHIP	3.3K 2% 1/8W
R847	1-216-206-00	RES,CHIP	2.2K 2% 1/8W
R848	1-216-206-00	RES,CHIP	2.2K 2% 1/8W
R849	1-216-206-00	RES,CHIP	2.2K 2% 1/8W
R906	1-216-210-00	RES,CHIP	3.3K 2% 1/8W
R943	1-244-901-11	RES,CHIP	15K 5% 1/2W
R944	1-244-901-11	RES,CHIP	15K 5% 1/2W
R945	1-244-901-11	RES,CHIP	15K 5% 1/2W
R946	1-244-901-11	RES,CHIP	15K 5% 1/2W
< VARIABLE RESISTOR >			
RV101	1-241-761-11	RES, ADJ, CARBON 1K (IDLING)(L-ch)	
RV201	1-241-761-11	RES, ADJ, CARBON 1K (IDLING)(R-ch)	
< SWITCH >			
S803	1-572-185-11	SWITCH, SLIDE (FILTER)	

Ref. No.	Part No.	Description	Remark
< THERMISTOR >			
TH801	1-809-664-51	THERMISTOR, POSITIVE	
TH802	1-809-664-51	THERMISTOR, POSITIVE	
< VARIABLE RESISTOR >			
VR801	1-225-647-11	RES, VAR 20K/20K/20K/20K (LEVEL)	
VR802	1-225-648-11	RES, VAR 5K/5K (LOW BOOST)	
VR803	1-225-648-11	RES, VAR 5K/5K (FILTER)	
*****			
(Including in AMP/POWER BOARD, COMPLETE)			
POWER BOARD			
*****			
< CAPACITOR >			
C810	1-163-227-11	CERAMIC CHIP	10PF 0.5PF 50V
C811	1-163-227-11	CERAMIC CHIP	10PF 0.5PF 50V
C901	1-163-021-11	CERAMIC CHIP	0.01uF 10% 50V
C902	1-130-471-00	MYLAR	0.001uF 5% 50V
C903	1-128-551-11	ELECT	22uF 20% 25V
C904	1-126-933-11	ELECT	100uF 20% 16V
C905	1-126-933-11	ELECT	100uF 20% 16V
C906	1-163-141-00	CERAMIC CHIP	0.001uF 5% 50V
C907	1-163-141-00	CERAMIC CHIP	0.001uF 5% 50V
C908	1-163-141-00	CERAMIC CHIP	0.001uF 5% 50V
C909	1-136-173-00	FILM	0.47uF 5% 50V
C910	1-165-319-11	CERAMIC CHIP	0.1uF 50V
C911	1-136-161-00	FILM	0.047uF 5% 50V
C912	1-111-044-11	ELECT	2200uF 20% 16V
C913	1-111-044-11	ELECT	2200uF 20% 16V
C914	1-111-044-11	ELECT	2200uF 20% 16V
C915	1-136-161-00	FILM	0.047uF 5% 50V
C916	1-111-044-11	ELECT	2200uF 20% 16V
C917	1-111-044-11	ELECT	2200uF 20% 16V
C918	1-111-044-11	ELECT	2200uF 20% 16V
C919	1-126-052-11	ELECT	100uF 20% 50V
C920	1-126-052-11	ELECT	100uF 20% 50V
C921	1-126-052-11	ELECT	100uF 20% 50V
C922	1-126-052-11	ELECT	100uF 20% 50V
C923	1-130-321-00	FILM	0.1uF 5% 100V
C924	1-130-321-00	FILM	0.1uF 5% 100V
C925	1-130-321-00	FILM	0.1uF 5% 100V
C926	1-130-321-00	FILM	0.1uF 5% 100V
C927	1-128-493-11	ELECT	4700uF 20% 63V
C928	1-128-493-11	ELECT	4700uF 20% 63V
C929	1-128-493-11	ELECT	4700uF 20% 63V
C930	1-128-493-11	ELECT	4700uF 20% 63V
C931	1-128-230-11	ELECT	100uF 20% 80V
C932	1-128-230-11	ELECT	100uF 20% 80V
C933	1-128-230-11	ELECT	100uF 20% 80V
C934	1-128-230-11	ELECT	100uF 20% 80V
C935	1-165-319-11	CERAMIC CHIP	0.1uF 50V
C936	1-165-319-11	CERAMIC CHIP	0.1uF 50V
C937	1-165-319-11	CERAMIC CHIP	0.1uF 50V
C938	1-165-319-11	CERAMIC CHIP	0.1uF 50V
C939	1-126-023-11	ELECT	100uF 20% 16V

Ref. No.	Part No.	Description	Remark	Ref. No.	Part No.	Description	Remark
C940	1-126-023-11	ELECT	100uF 20% 16V			< FUSE >	
C941	1-126-023-11	ELECT	100uF 20% 16V				
C942	1-126-023-11	ELECT	100uF 20% 16V	F901	1-533-743-11	FUSE (BLADE TYPE)(AUTO FUSE)(40A)	
C959	1-163-021-11	CERAMIC CHIP	0.01uF 10% 50V	F902	1-533-743-11	FUSE (BLADE TYPE)(AUTO FUSE)(40A)	
						< FAN MOTOR >	
C960	1-163-021-11	CERAMIC CHIP	0.01uF 10% 50V				
C965	1-128-551-11	ELECT	22uF 20% 25V				
						< IC >	
		< CONNECTOR >					
CN801	1-537-920-21	TERMINAL BOARD (2P)(+12V, GND)					
CNJ801	1-793-279-11	CONNECTOR 1P (REMOTE)		IC901	8-759-144-88	IC $\mu$ PC494GS	
CNJ802	1-766-902-11	CONNECTOR, FFC/FPC (ZIF) 9P		IC903	8-719-156-73	IC PHOTO COUPLER PS2501-1LA	
* CNP801	1-564-704-11	PIN, CONNECTOR (SMALL TYPE) 2P (FN801)				< COIL >	
		< DIODE >					
D805	8-719-801-78	DIODE 1SS184		L901	1-424-112-11	INDUCTOR 7.5uH	
D806	8-719-801-78	DIODE 1SS184		L902	1-424-112-11	INDUCTOR 7.5uH	
D807	8-719-158-49	DIODE RD12SB2		L903	1-410-396-71	INDUCTOR 0.45uH	
D901	8-719-025-33	DIODE 02CZ6.2-TE85L		L904	1-410-396-71	INDUCTOR 0.45uH	
D902	8-719-025-50	DIODE 02CZ16-TE85L				< DIODE >	
D903	8-719-987-67	DIODE 11EFS2		LD804	8-719-070-01	DIODE SEC2764C (HI-VOLTAGE)	
D904	8-719-987-67	DIODE 11EFS2		LD805	8-719-070-01	DIODE SEC2764C (HI-CURRENT)	
D905	8-719-987-67	DIODE 11EFS2				< PILOT LAMP >	
D906	8-719-987-67	DIODE 11EFS2					
D907	8-719-987-67	DIODE 11EFS2		PL801	1-518-540-00	LAMP, PILOT	
						< TRANSISTOR >	
D908	8-719-987-67	DIODE 11EFS2					
D909	8-719-987-67	DIODE 11EFS2		Q814	8-729-216-21	TRANSISTOR 2SA1162-Y	
D910	8-719-987-67	DIODE 11EFS2		Q815	8-729-032-94	TRANSISTOR 2SD1859TV2Q	
D911	8-719-054-55	DIODE 1SS306(TE85L)		Q901	8-729-041-38	TRANSISTOR 2SB1241TV2Q	
D912	8-719-054-55	DIODE 1SS306(TE85L)		Q902	8-729-216-21	TRANSISTOR 2SA1162-Y	
				Q903	8-729-230-49	TRANSISTOR 2SC2712-YG	
D913	8-719-054-55	DIODE 1SS306(TE85L)					
D914	8-719-054-55	DIODE 1SS306(TE85L)		Q904	8-729-030-72	TRANSISTOR MTAJ50N05HD	
D915	8-719-210-30	DIODE F10P20F(R)		Q905	8-729-030-72	TRANSISTOR MTAJ50N05HD	
D916	8-719-210-30	DIODE F10P20F(R)		Q906	8-729-030-72	TRANSISTOR MTAJ50N05HD	
D917	8-719-210-30	DIODE F10P20F(R)		Q907	8-729-030-72	TRANSISTOR MTAJ50N05HD	
				Q908	8-729-030-72	TRANSISTOR MTAJ50N05HD	
D918	8-719-210-30	DIODE F10P20F(R)					
D919	8-719-210-30	DIODE F10P20F(R)		Q909	8-729-030-72	TRANSISTOR MTAJ50N05HD	
D920	8-719-210-30	DIODE F10P20F(R)		Q910	8-729-030-72	TRANSISTOR MTAJ50N05HD	
D921	8-719-210-30	DIODE F10P20F(R)		Q911	8-729-030-72	TRANSISTOR MTAJ50N05HD	
D922	8-719-210-30	DIODE F10P20F(R)		Q912	8-729-230-49	TRANSISTOR 2SC2712-YG	
				Q913	8-729-230-49	TRANSISTOR 2SC2712-YG	
D925	8-719-820-05	DIODE 1SS181					
D926	8-719-025-49	DIODE 02CZ15-TE85L		Q914	8-729-230-49	TRANSISTOR 2SC2712-YG	
D927	8-719-025-49	DIODE 02CZ15-TE85L		Q915	8-729-230-49	TRANSISTOR 2SC2712-YG	
D928	8-719-025-49	DIODE 02CZ15-TE85L		Q916	8-729-106-60	TRANSISTOR 2SB1115A	
D929	8-719-025-49	DIODE 02CZ15-TE85L		Q917	8-729-106-60	TRANSISTOR 2SB1115A	
				Q918	8-729-207-82	TRANSISTOR 2SC3421-Y	
D934	8-719-200-82	DIODE 11ES2					
D935	8-719-200-82	DIODE 11ES2		Q919	8-729-207-82	TRANSISTOR 2SC3421-Y	
D936	8-719-200-82	DIODE 11ES2		Q920	8-729-207-89	TRANSISTOR 2SA1358-Y	
D937	8-719-200-82	DIODE 11ES2		Q921	8-729-207-89	TRANSISTOR 2SA1358-Y	
D938	8-719-056-97	DIODE UDZ-TE-17-27B		Q926	8-729-230-49	TRANSISTOR 2SC2712-YG	
				Q927	8-729-119-78	TRANSISTOR 2SC403SP-5H	
D939	8-719-056-97	DIODE UDZ-TE-17-27B				< RESISTOR >	
D940	8-719-056-97	DIODE UDZ-TE-17-27B					
D941	8-719-977-81	DIODE DTZ33B		R833	1-216-663-11	METAL CHIP 3.3K 0.5% 1/10W	
D942	8-719-801-78	DIODE 1SS184		R834	1-216-667-11	METAL CHIP 4.7K 0.5% 1/10W	
D943	8-719-820-05	DIODE 1SS181		R835	1-216-663-11	METAL CHIP 3.3K 0.5% 1/10W	
				R836	1-216-667-11	METAL CHIP 4.7K 0.5% 1/10W	
D944	8-719-801-78	DIODE 1SS184		R837	1-216-663-11	METAL CHIP 3.3K 0.5% 1/10W	
D945	8-719-056-78	DIODE UDZ-TE-17-4.3B					

**POWER**

Ref. No.	Part No.	Description	Quantity	Power	Remark
R838	1-208-770-11	RES,CHIP	330	2%	1/10W
R839	1-216-663-11	METAL CHIP	3.3K	0.5%	1/10W
R840	1-208-770-11	RES,CHIP	330	2%	1/10W
R841	1-218-760-11	RES,CHIP	220K	2%	1/10W
R842	1-216-635-11	METAL CHIP	220	0.5%	1/10W
R844	1-208-770-11	RES,CHIP	330	2%	1/10W
R845	1-216-651-11	METAL CHIP	1K	0.5%	1/10W
R846	1-216-655-11	METAL CHIP	1.5K	0.5%	1/10W
R901	1-208-806-11	RES,CHIP	10K	2%	1/10W
R902	1-216-663-11	METAL CHIP	3.3K	0.5%	1/10W
R903	1-208-518-61	RES,CHIP	22K	2%	1/10W
R904	1-208-812-11	RES,CHIP	18K	2%	1/10W
R905	1-216-103-00	METAL CHIP	180K	5%	1/10W
R907	1-216-202-00	RES,CHIP	1.5K	2%	1/8W
R908	1-216-202-00	RES,CHIP	1.5K	2%	1/8W
R909	1-216-663-11	METAL CHIP	3.3K	0.5%	1/10W
R910	1-216-667-11	METAL CHIP	4.7K	0.5%	1/10W
R911	1-249-576-11	CARBON	10K	5%	1/4W
R912	1-208-474-61	RES,CHIP	330	2%	1/8W
R913	1-208-486-61	RES,CHIP	1K	2%	1/8W
R914	1-208-486-61	RES,CHIP	1K	2%	1/8W
R915	1-216-651-11	METAL CHIP	1K	0.5%	1/10W
R916	1-216-651-11	METAL CHIP	1K	0.5%	1/10W
R917	1-216-651-11	METAL CHIP	1K	0.5%	1/10W
R918	1-216-651-11	METAL CHIP	1K	0.5%	1/10W
R919	1-216-651-11	METAL CHIP	1K	0.5%	1/10W
R920	1-216-651-11	METAL CHIP	1K	0.5%	1/10W
R921	1-208-397-11	RES,CHIP	22	2%	1/8W
R922	1-208-397-11	RES,CHIP	22	2%	1/8W
R923	1-208-397-11	RES,CHIP	22	2%	1/8W
R924	1-208-397-11	RES,CHIP	22	2%	1/8W
R925	1-208-373-11	RES,CHIP	2.2	2%	1/8W
R926	1-208-373-11	RES,CHIP	2.2	2%	1/8W
R927	1-208-373-11	RES,CHIP	2.2	2%	1/8W
R928	1-208-373-11	RES,CHIP	2.2	2%	1/8W
R929	1-208-373-11	RES,CHIP	2.2	2%	1/8W
R930	1-208-373-11	RES,CHIP	2.2	2%	1/8W
R931	1-208-373-11	RES,CHIP	2.2	2%	1/8W
R932	1-208-373-11	RES,CHIP	2.2	2%	1/8W
R933	1-208-365-61	RES,CHIP	100	2%	1/10W
R934	1-208-365-61	RES,CHIP	100	2%	1/10W
R935	1-208-486-61	RES,CHIP	1K	2%	1/8W
R936	1-216-651-11	METAL CHIP	1K	0.5%	1/10W
R937	1-215-863-11	METAL OXIDE	100	5%	1W F
R938	1-215-863-11	METAL OXIDE	100	5%	1W F
R939	1-208-506-11	RES,CHIP	6.8K	2%	1/8W
R940	1-208-506-11	RES,CHIP	6.8K	2%	1/8W
R941	1-208-506-11	RES,CHIP	6.8K	2%	1/8W
R942	1-208-506-11	RES,CHIP	6.8K	2%	1/8W
R947	1-216-206-00	RES,CHIP	2.2K	2%	1/8W
R948	1-216-206-00	RES,CHIP	2.2K	2%	1/8W
R949	1-216-206-00	RES,CHIP	2.2K	2%	1/8W
R950	1-216-210-00	RES,CHIP	3.3K	2%	1/8W
R951	1-216-210-00	RES,CHIP	3.3K	2%	1/8W
R952	1-216-206-00	RES,CHIP	2.2K	2%	1/8W
R953	1-216-206-00	RES,CHIP	2.2K	2%	1/8W
R955	1-208-526-61	RES,CHIP	47K	2%	1/10W
R956	1-208-806-11	RES,CHIP	10K	2%	1/10W

Ref. No.	Part No.	Description	Quantity	Power	Remark
R957	1-216-667-11	METAL CHIP	4.7K	0.5%	1/10W
R958	1-216-635-11	METAL CHIP	220	0.5%	1/10W
< SWITCH >					
S801	1-771-387-11	SWITCH, TOGGLE (HI-CURRENT)			
S802	1-771-387-11	SWITCH, TOGGLE (HI-VOLTAGE)			
< TRANSFORMER >					
T901	1-433-939-11	TRANSFORMER, DC-DC CONVERTER			
T902	1-433-939-11	TRANSFORMER, DC-DC CONVERTER			
< THERMISTOR >					
TH803	1-810-506-11	THERMISTOR NTH5G39B223K01 (22K)			
TH804	1-810-506-11	THERMISTOR NTH5G39B223K01 (22K)			
TH805	1-810-506-11	THERMISTOR NTH5G39B223K01 (22K)			
TH901	1-810-506-11	THERMISTOR NTH5G39B223K01 (22K)			
*****					
MISCELLANEOUS					
*****					
F901	1-533-743-11	FUSE (BLADE TYPE) (AUTO FUSE) (40A)			
F902	1-533-743-11	FUSE (BLADE TYPE) (AUTO FUSE) (40A)			
FN801	1-763-107-11	MOTOR, FAN			
TH801	1-809-664-51	THERMISTOR, POSITIVE			
TH802	1-809-664-51	THERMISTOR, POSITIVE			
*****					
ACCESSORIES & PACKING MATERIALS					
*****					
3-037-683-01		COVER, 2P TERMINAL TABLE			
3-367-410-01		SCREW (DIA. 5X15), TAPPING			
3-866-284-11		MANUAL, INSTRUCTION (EXCEPT G) (ENGLISH, FRENCH)			
3-866-284-21		MANUAL, INSTRUCTION (AEP,UK,G) (GERMAN, ITALIAN)			
3-866-284-31		MANUAL, INSTRUCTION (AEP,UK,G) (SPANISH, PORTUGUESE)			
3-866-284-41		MANUAL, INSTRUCTION (AEP,UK,G) (DUTCH, SWEDISH)			
*****					
*****					
HARDWARE LIST					
*****					
#1	7-685-544-14	+BTP 3x5 TYPE2 N-S			
#2	7-685-546-19	+BTP 3x8 TYPE2 N-S			
#3	7-685-797-09	+PTT 2.6x16 (S)			
#4	7-685-646-79	+P 3x8 TYPE2 N-S			
#5	7-685-144-11	+P 3x5 TYPE2 N-S			
#6	7-682-546-09	SCREW +B 3x5			
#7	7-685-660-79	+P 4x10 TYPE2 N-S			
#8	7-685-645-79	+P 3x6 TYPE2 N-S			
#9	7-682-949-01	+PSW 3x10			
#10	7-685-649-79	+P 3x14 TYPE2 N-S			