

WM-EX500/EX505

SERVICE MANUAL

Ver 1.0 2000.01



Photo: WM-EX505

AEP Model
WM-EX500/EX505

E Model
WM-EX505

Dolby noise reduction manufactured under license from Dolby Laboratories Licensing Corporation. "DOLBY" and the double-D symbol $\square\square$ are trademarks of Dolby Laboratories Licensing Corporation.

Model Name Using Similar Mechanism	NEW
Tape Transport Mechanism Type	MT-WMEX505-162

SPECIFICATIONS

- **Frequency response (Dolby NR off (WM-EX505))**
Playback: 30 - 18,000 Hz
- **Output**
Headphones (ϕ jack)
Load impedance 8 - 300 ohms
- **Power requirements**
1.5 V
One R6 (size AA) battery
- **Dimensions (w/h/d)**
Approx. 78.7 x 109.7 x 28.1 mm, incl. projecting parts and controls
- **Mass**
Approx. 145 g
Approx. 200 g (incl. a battery and a cassette)
- **Supplied accessories**
Stereo headphones or earphones with remote control (1)
(WM-EX505)
Stereo headphones or earphones (1) (WM-EX500)

Design and specifications are subject to change without notice.

Battery life (Approx. hours)	(EIAJ*)
	Sony alkaline LR6 (SG)
Tape playback	35

* Measured value by the standard of EIAJ (Electronic Industries Association of Japan). (Using a Sony HF series cassette tape)

Note

- The battery life may shorten depending on the operation of the unit.

CASSETTE PLAYER

SONY®



TABLE OF CONTENTS

1. SERVICING NOTES	3
2. GENERAL	5
3. DISASSEMBLY	6
4. MECHANICAL ADJUSTMENTS	12
5. ELECTRICAL ADJUSTMENTS	12
6. DIAGRAMS	
6-1. Block Diagram	13
6-2. Printed Wiring Board	15
6-3. Schematic Diagram	17
6-4. IC Pin Function Description	22
7. EXPLODED VIEWS	24
8. ELECTRICAL PARTS LIST	26

Flexible Circuit Board Repairing

- Keep the temperature of the soldering iron around 270 °C during repairing.
- Do not touch the soldering iron on the same conductor of the circuit board (within 3 times).
- Be careful not to apply force on the conductor when soldering or unsoldering.

Notes on chip component replacement

- Never reuse a disconnected chip component.
- Notice that the minus side of a tantalum capacitor may be damaged by heat.

SECTION 1 SERVICING NOTES

This set detects the rotation of the idler gear (A) (side S) using the PH701 (photo reflector). The PH701 is mounted on the MAIN board, therefore the idler gear (A) (side S) cannot be detected with the MAIN board removed. As a result, the motor (M901) cannot be controlled, causing malfunction.

Further, the DIRECTION switch (S701) is also mounted on the MAIN board, and with the board removed, the mechanism position cannot be detected and the operation is not changed over.

Therefore, when the voltage check is executed with the MAIN board removed, follow the procedure provided below.

1. Setting



- (1) Refer to "3. DISASSEMBLY", and remove the MAIN board.
- (2) Connect the MAIN board to the motor (M901) and the plunger (PM901) using jumper wires. These can be connected easily with the use of the extension tool (Part No. 1-769-143-11) (ten in one set).
- (3) Short the TAPE DETECT switch (S901-1) terminals and the ATS switch (S901-2) terminals.
- (4) Connect the AF oscillator to the TP36 (PHOTO IN) and the TP46 (GND).
- (5) Supply 1.3 V to the battery terminals using the regulated power supply.

2. Preset state



To set the PLAY, FF, REW modes, the preset state must be set.

- (1) Check that the slider (NR) and the DIRECTION switch (S701) are set to the center position. If not, set the preset state as follow.
- (2) Move the DIRECTION switch (S701) to the side, which the slider (NR) is facing.
- (3) The slider (NR) will move when the regulated power supply switch is set to OFF once and then set to ON. Move the DIRECTION switch (S701) according to this timing and set to the center position.



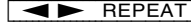

3. FF, REW modes

- (1) Check that the preset state is set.
- (2) Input the square wave or sine wave to the TP36 (PHOTO IN) and the TP46 (GND).
- (3) Press the  button (S702) to set the STOP mode.
- (4) Press the  button (S704) or the  button (S705).

4. PLAY mode

- (1) Check that the preset state is set.
- (2) Input the square wave or sine wave to the TP36 (PHOTO IN) and the TP46 (GND).
- (3) Press the  button (S702) to set the STOP mode.
- (4) Press the  button (S703) will move the slider (NR) once towards the side R and then to the side F. Move the DIRECTION switch (S701) according to this timing will set the PLAY mode (side F). Press the  button (S703) another time and move the DIRECTION switch (S701) according to the movement of the slider (NR) will set the PLAY (R mode).

Note 1: If the above fails, perform from preset again.

Note 2: Use the  (S703),  (S702),  (S704), and  (S705) buttons on the remote controller as much as possible. If no remote controller, do not touch the buttons with your hands, but using a stick with a round tip.

Note 3: When using headphones, the timing for move the DIRECTION switch (S701) can be determined from the beep sound.

- MAIN Board (Side B) -

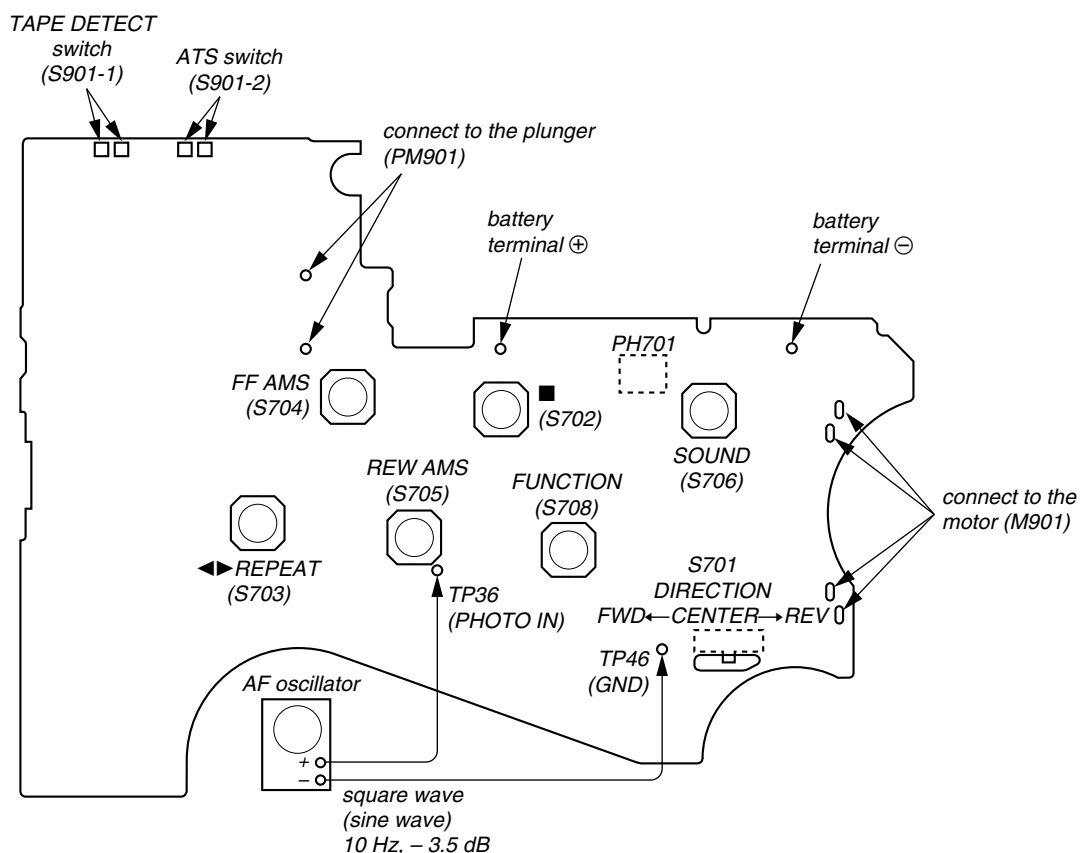

SLIDER (NRA)

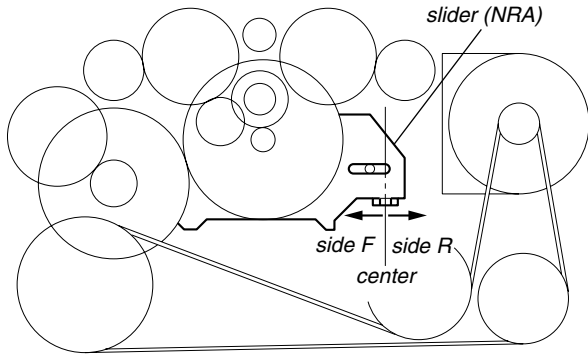

Rotation system

Rotation system during PLAY

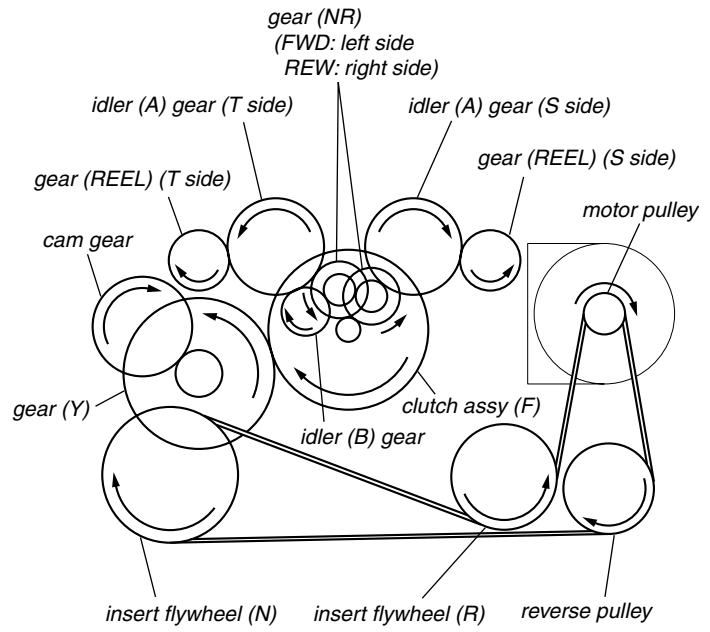

Rotation system during FF

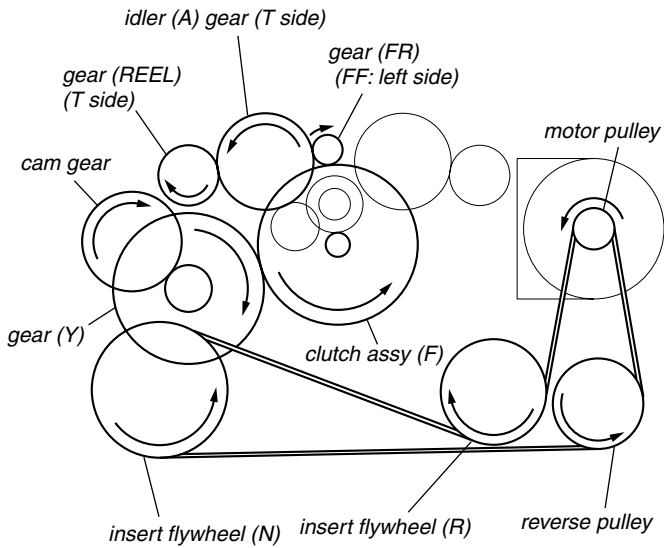

Rotation system during REW

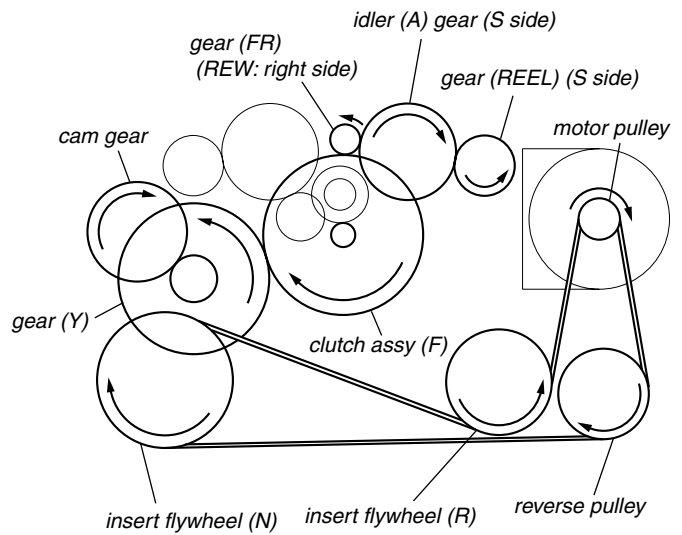

SECTION 2 GENERAL

This section is extracted from instruction manual.

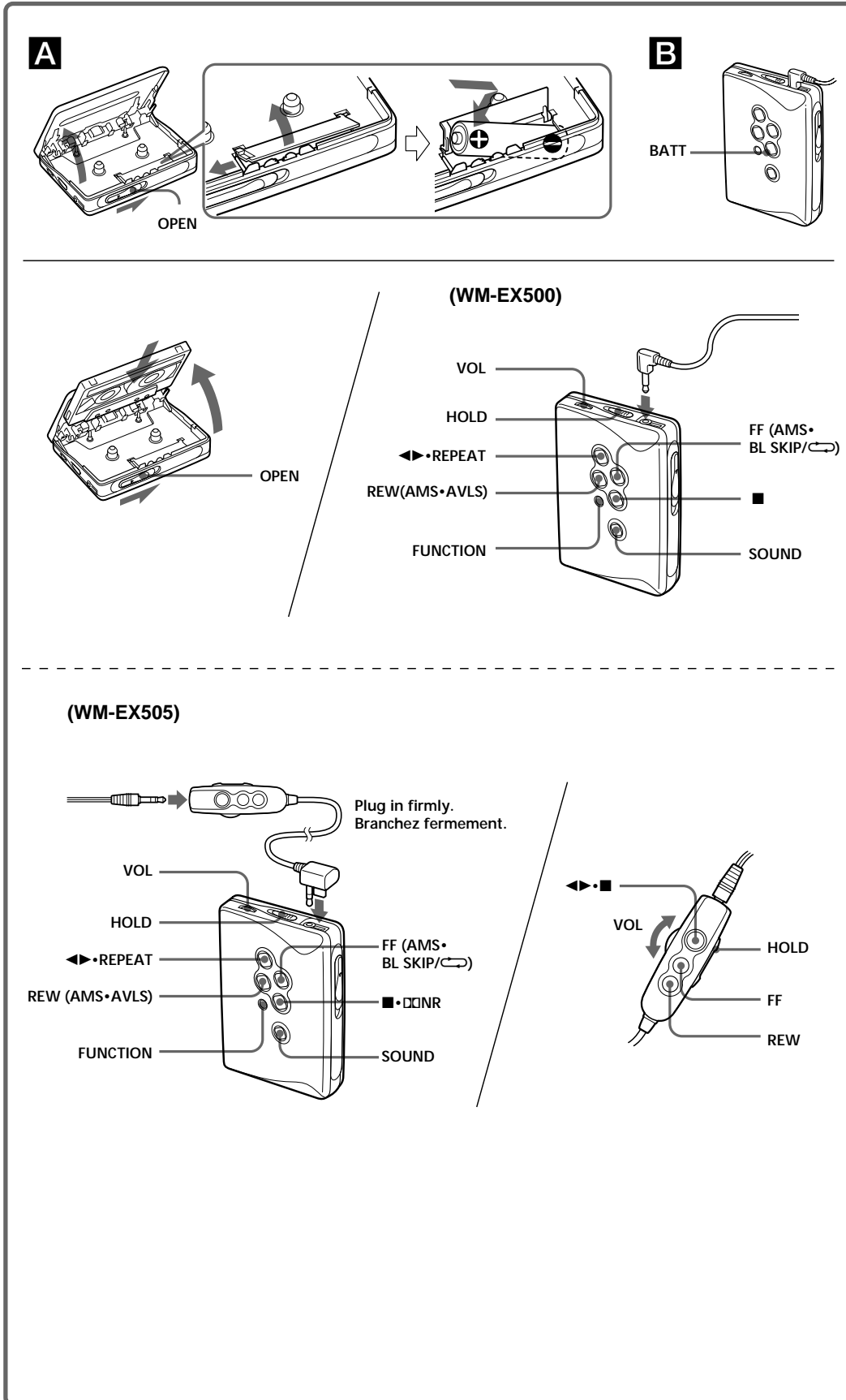

SECTION 3 DISASSEMBLY

• This set can be disassembled in the order shown below.

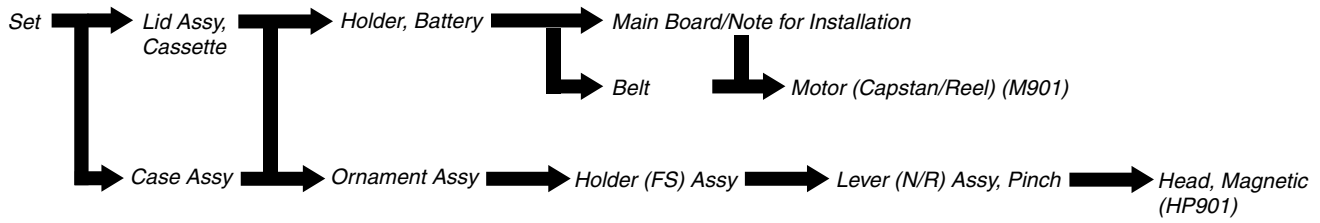

Note: Follow the disassembly procedure in the numerical order given.

LID ASSY, CASSETTE

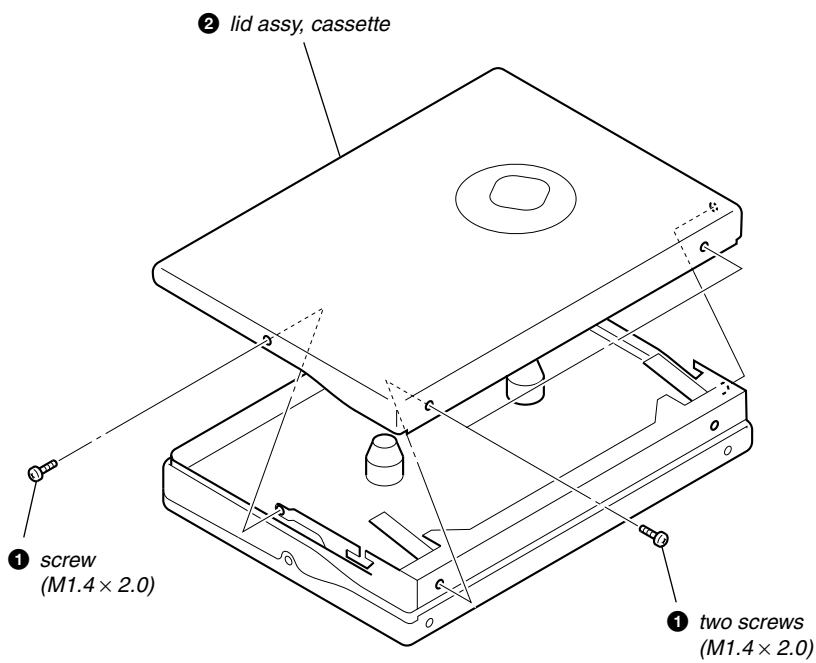

CASE ASSY

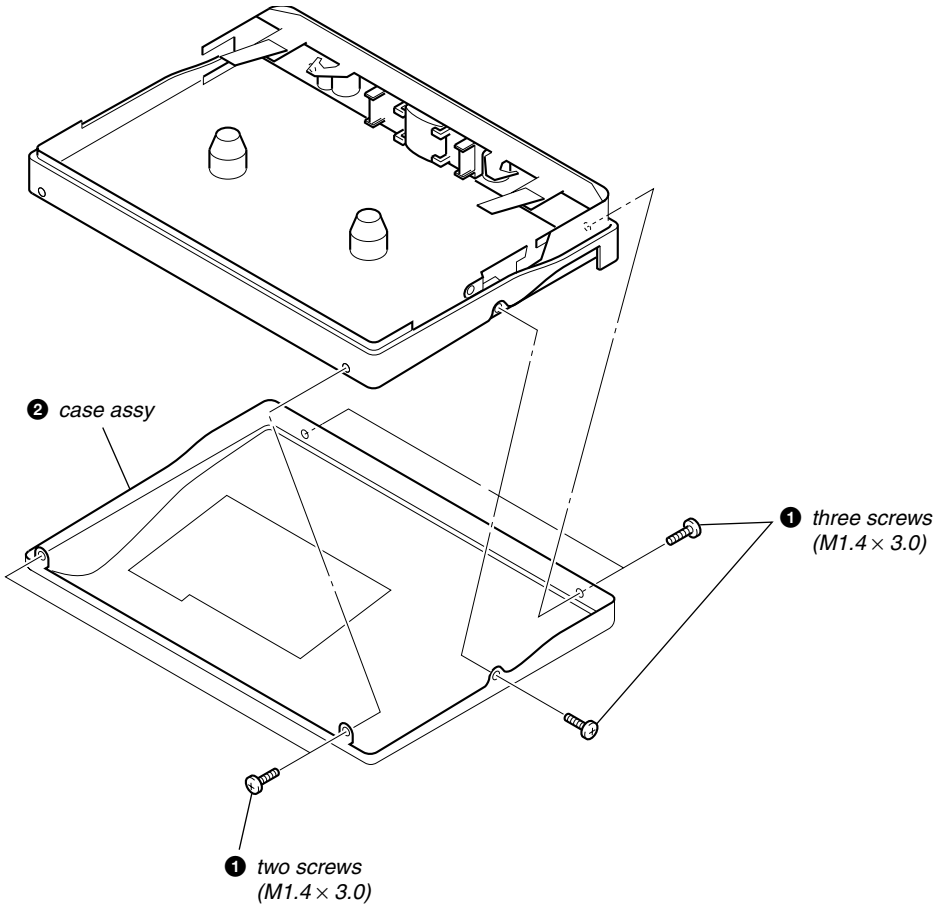

ORNAMENT ASSY

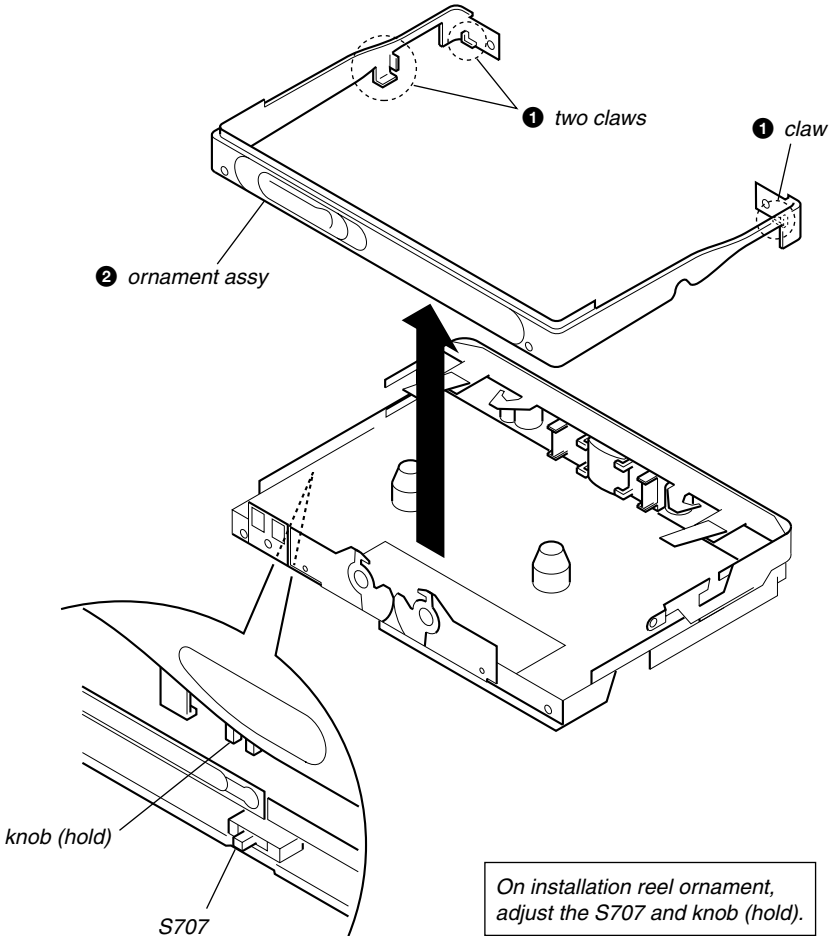

HOLDER, BATTERY

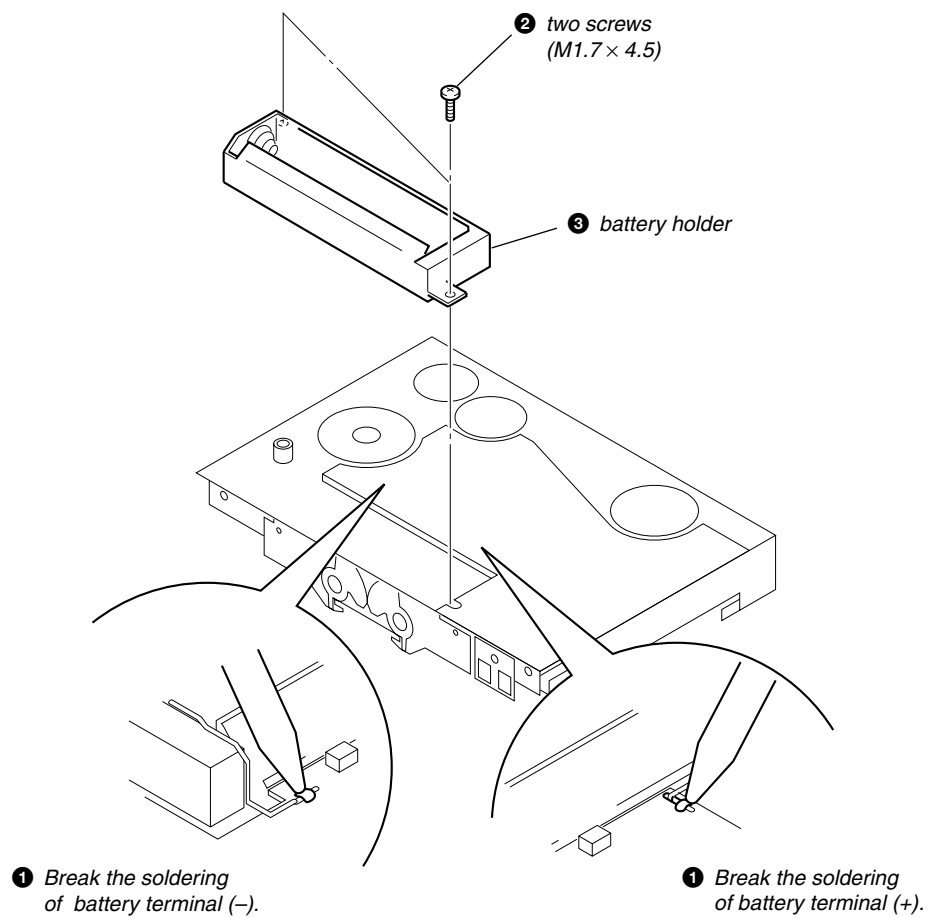

BELT

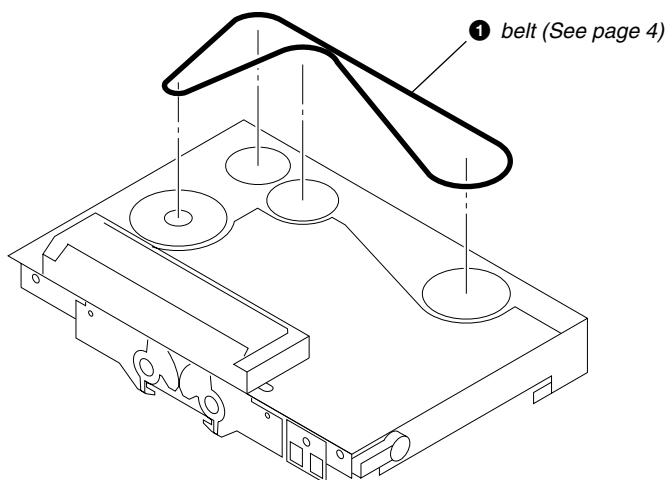

MAIN BOARD

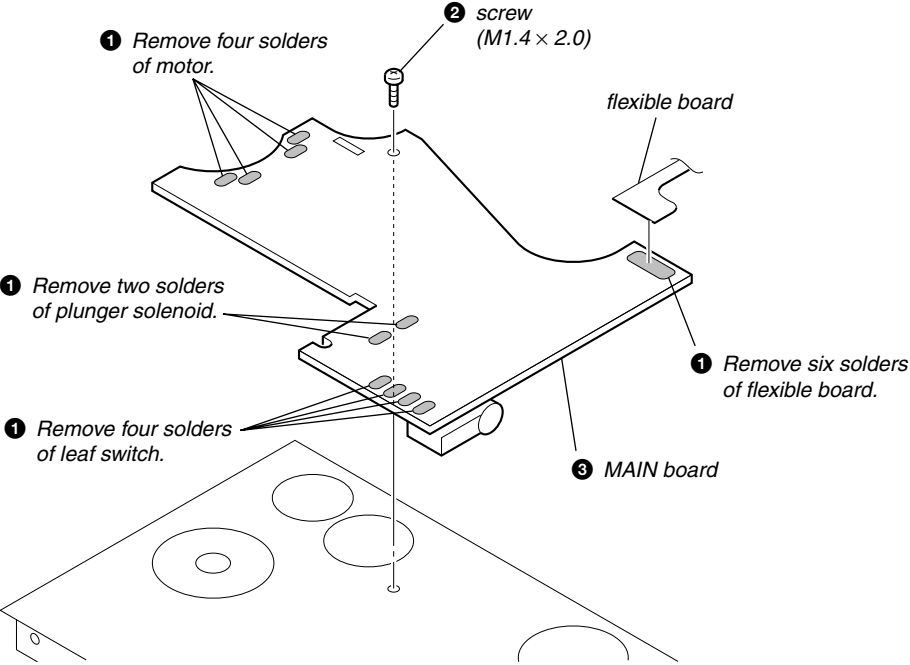

NOTE FOR INSTALLATION
• MAIN BOARD

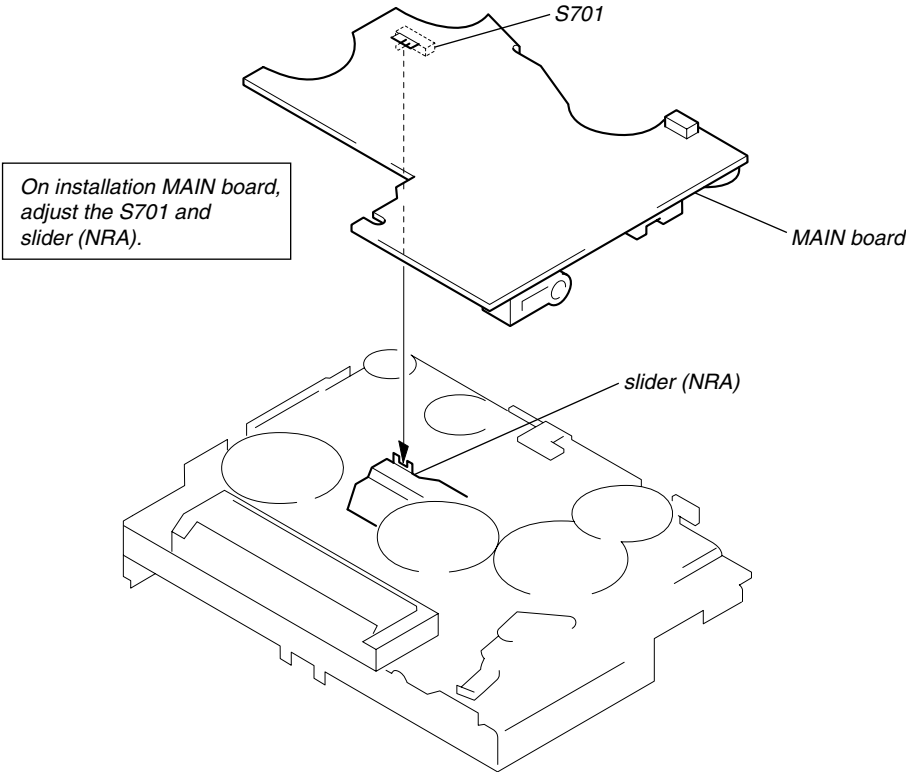

MOTOR (CAPSTAN/REEL) (M901)

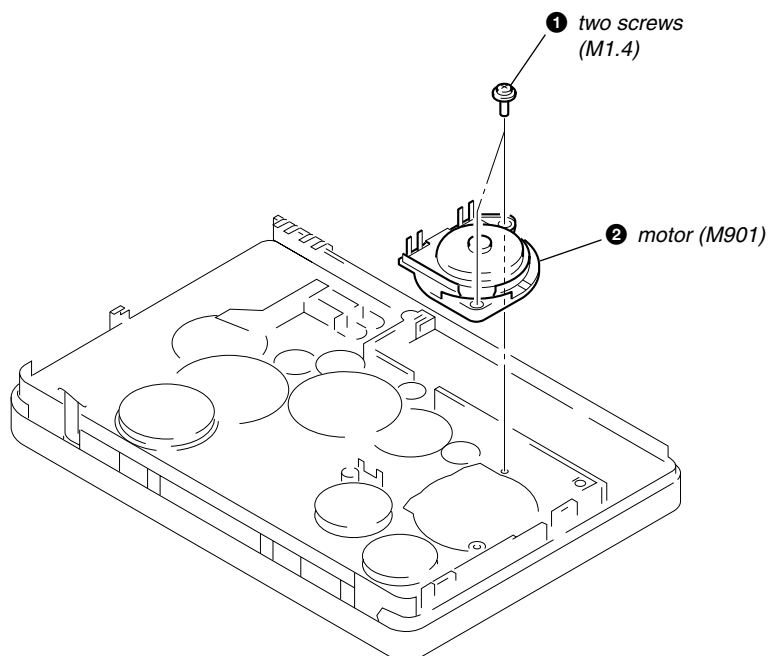

HOLDER (FS) ASSY

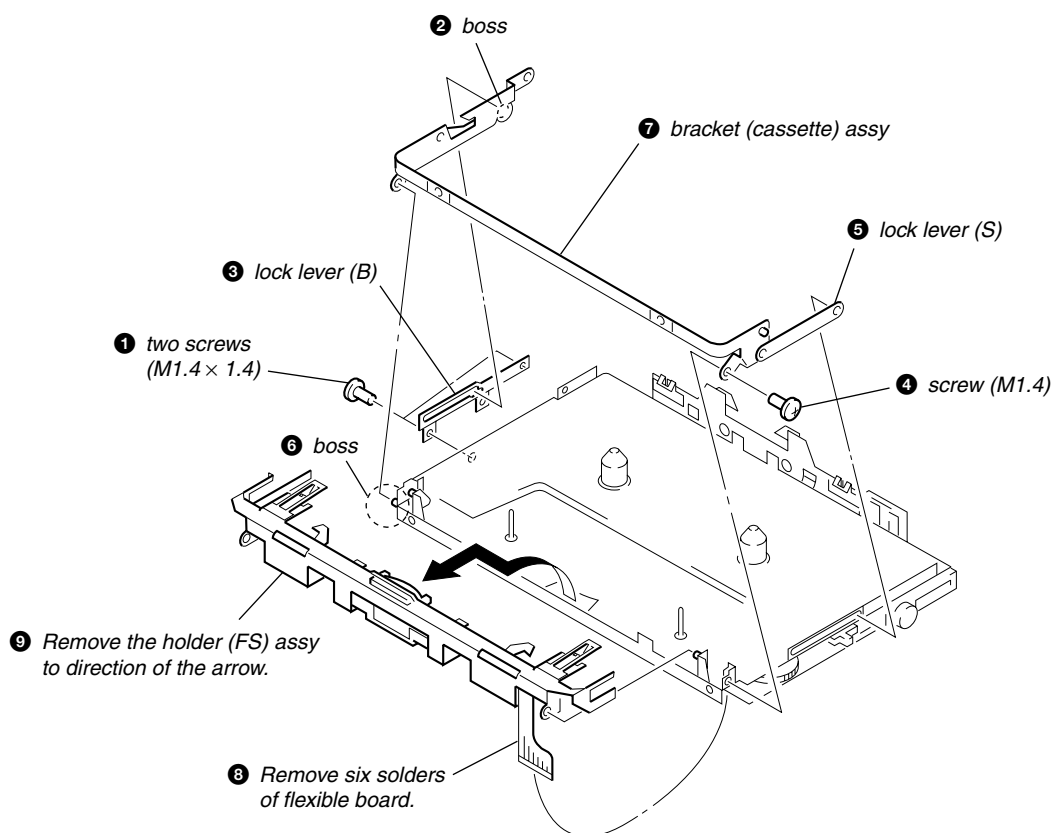

LEVER (N/R) ASSY, PINCH

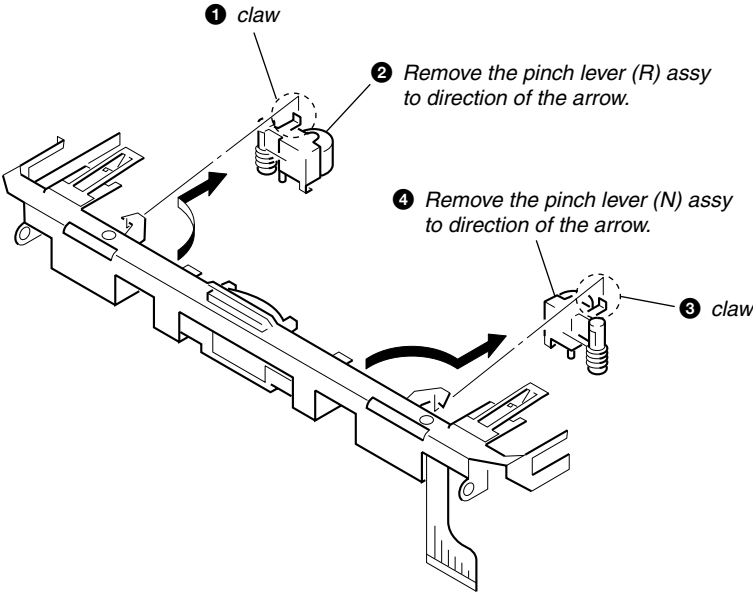

HEAD, MAGNETIC (HP901)

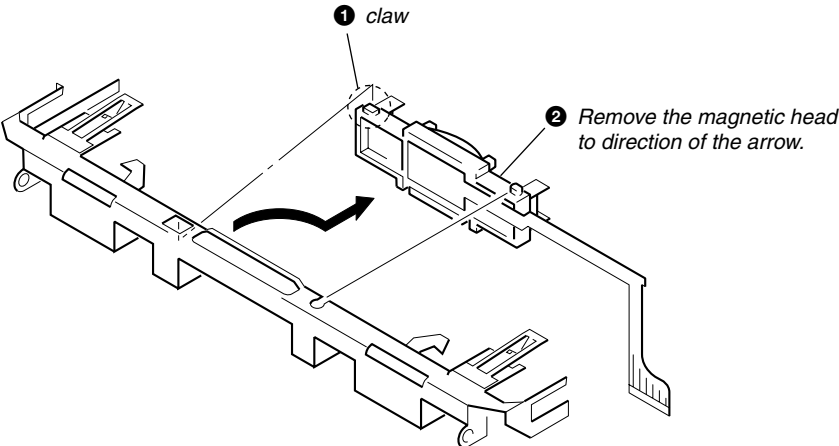

SECTION 4 MECHANICAL ADJUSTMENTS

PRECAUTION

1. Clean the following parts with a denatured-alcohol-moistened swab:

playback head	pinch roller
rubber belts	capstan
2. Demagnetize the playback head with a head demagnetizer. (Do not bring the head demagnetizer close to the erase head.)
3. The adjustments should be performed with the rated power supply voltage (1.3 V) unless otherwise noted.

Torque Measurement

Mode	Torque Meter	Meter Reading
FWD	CQ-102C	1.57 – 2.45 mN•m (16 – 25 g•cm) (0.23 – 0.34 oz•inch)
FWD Back Tension	CQ-102C	0.049 – 0.147 mN•m (0.5 – 1.5 g•cm) (0.007 – 0.02 oz•inch)
REV	CQ-102RC	1.57 – 2.45 mN•m (16 – 25 g•cm) (0.23 – 0.34 oz•inch)
REV Back Tension	CQ-102RC	0.049 – 0.147 mN•m (0.5 – 1.5 g•cm) (0.007 – 0.02 oz•inch)
FF, REW	CQ-201B	more than 4.90 mN•m (more than 50 g•cm) (more than 0.7 oz•inch)

SECTION 5 ELECTRICAL ADJUSTMENTS

PRECAUTION

1. Specified voltage : 1.3 V (DC)
2. Setting

BL SKIP	: OFF
SOUND NORM/MB/GRV	: NORM
AVLS	: OFF
□□NR (WM-EX505 only)	: OFF

Test tape

Type	Signal	Used for
WS-48A	3 kHz, 0 dB	Tape Speed Adjustment

Tape Speed Adjustment

Procedure:

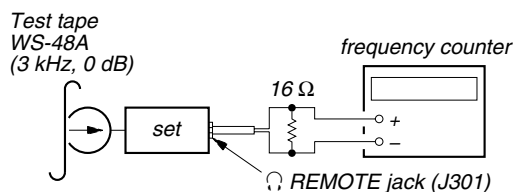

1. Playback WS-48A (tape center) in the FWD state.
2. Adjust RV601 so that the frequency counter reading becomes 3,000 Hz.

Specifcated Value: 2,970 to 3,030 Hz

3. Check that deflection of the frequency counter reading between the beginning and the end of tape is within 1.5% (approx. 45 Hz).

Adjustment Location:

– MAIN Board (Side B) –

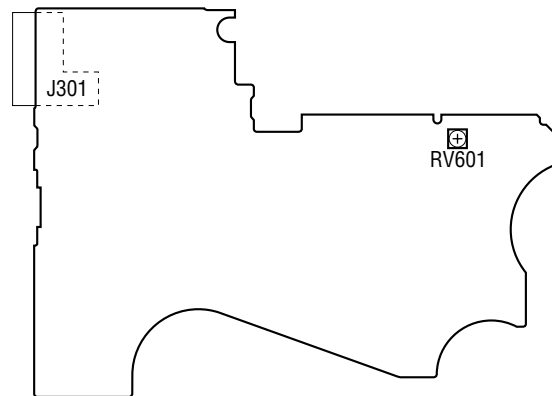

SECTION 6
DIAGRAMS

6-1. BLOCK DIAGRAM

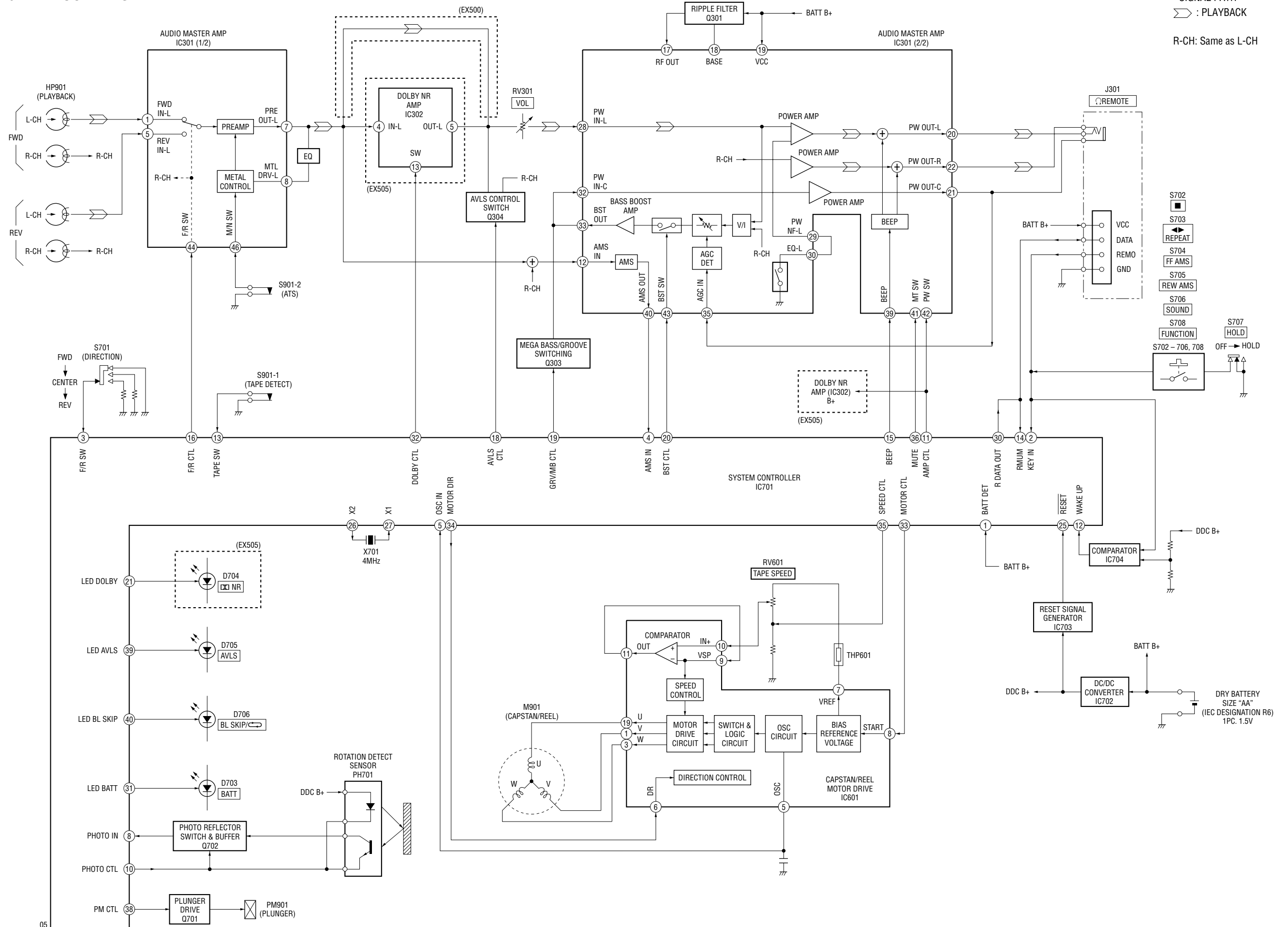

6-2. PRINTED WIRING BOARD

• Semiconductor Location

Ref. No.	Location
D701	E-16
D702	I-8
D703	H-13
D704	G-13
D705	F-12
D706	E-13
D709	C-16
D710	C-1
D711	C-1
IC301	C-6
IC302	C-4
IC601	J-13
IC701	F-4
IC702	H-8
IC703	D-2
IC704	H-11
PH701	I-4
Q301	B-6
Q303	C-15
Q304	C-3
Q701	G-4
Q702	J-4



Note on Printed Wiring Board:

- — : parts extracted from the component side.
- ○ : parts extracted from the conductor side.
- : Through hole.
- △ : internal component.
- ▨ : Pattern from the side which enables seeing. (The other layers' patterns are not indicated.)

Caution:

Pattern face side: Parts on the pattern face side seen from the pattern face are indicated.

Parts face side: Parts on the parts face side seen from the parts face are indicated.

6-3. SCHEMATIC DIAGRAM • See page 20 for IC Block Diagrams.

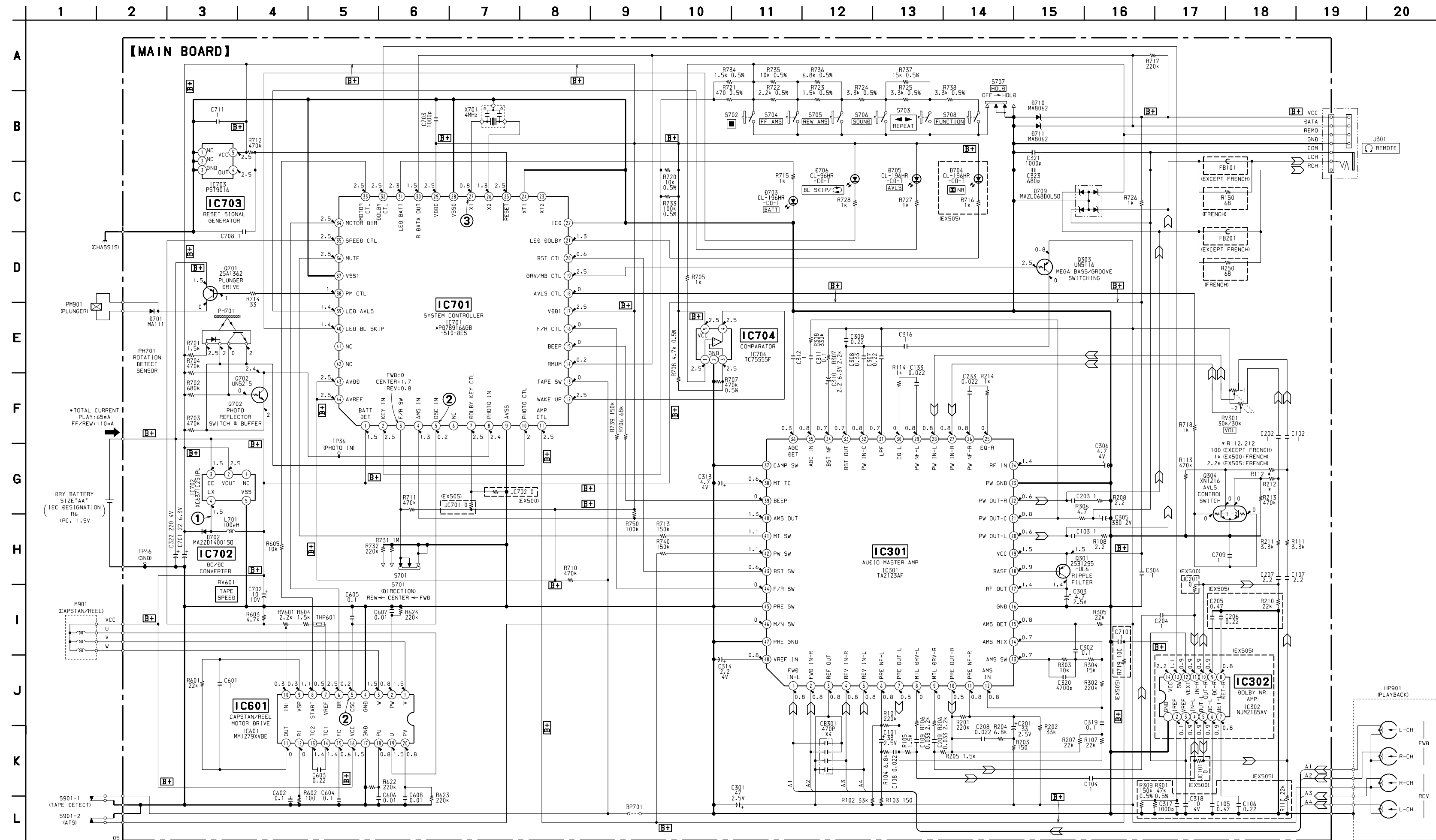

• Waveforms

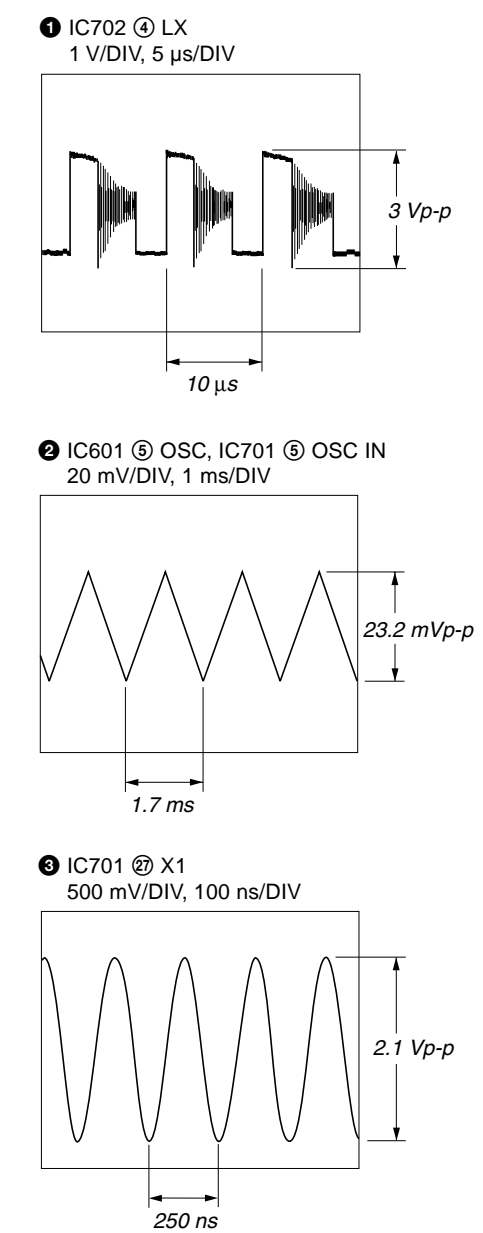

- Note on Schematic Diagram:**
- All capacitors are in μF unless otherwise noted. pF : μF
 - 50 WV or less are not indicated except for electrolytics and tantalums.
 - All resistors are in Ω and $1/4$ W or less unless otherwise specified.
 - % : indicates tolerance.
 - Δ : internal component.
 - \square : panel designation.
 - B+ : B+ Line.
 - \square : adjustment for repair.
 - Total current is measured with a cassette installed.
 - Power voltage is dc 1.5 V and fed with regulated dc power supply from battery terminal.
 - Voltages and waveforms are dc with respect to ground in playback mode.
 - no mark : PLAYBACK
 - Voltages are taken with a VOM (Input impedance 10 M Ω). Voltage variations may be noted due to normal production tolerances.
 - Waveforms are taken with an oscilloscope. Voltage variations may be noted due to normal production tolerances.
 - Circled numbers refer to waveforms.
 - Signal path.
 - \curvearrowright : PLAYBACK

• IC Block Diagrams

IC301 TA2123AF (EL)

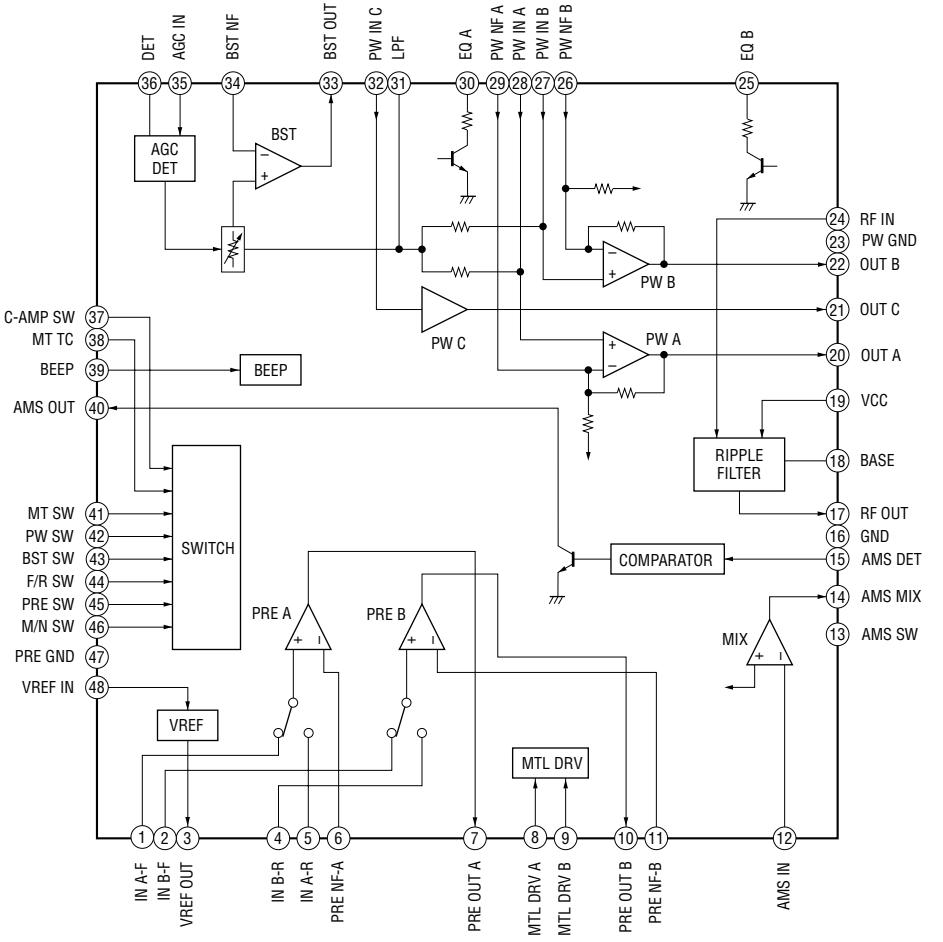

IC302 NJM2185AV-TE2

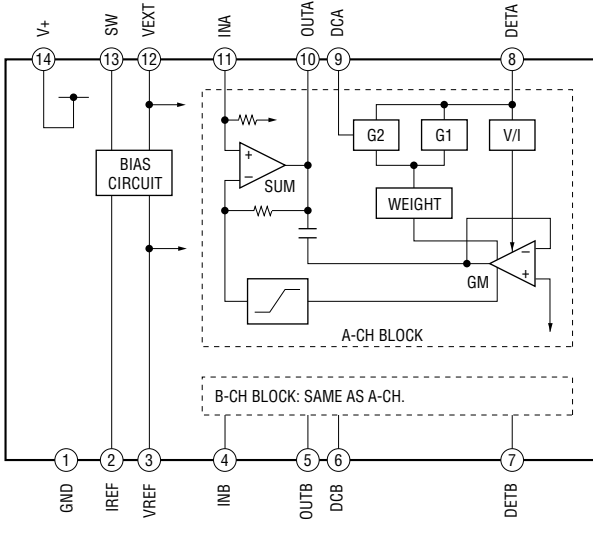

IC601 MM1279XVBE

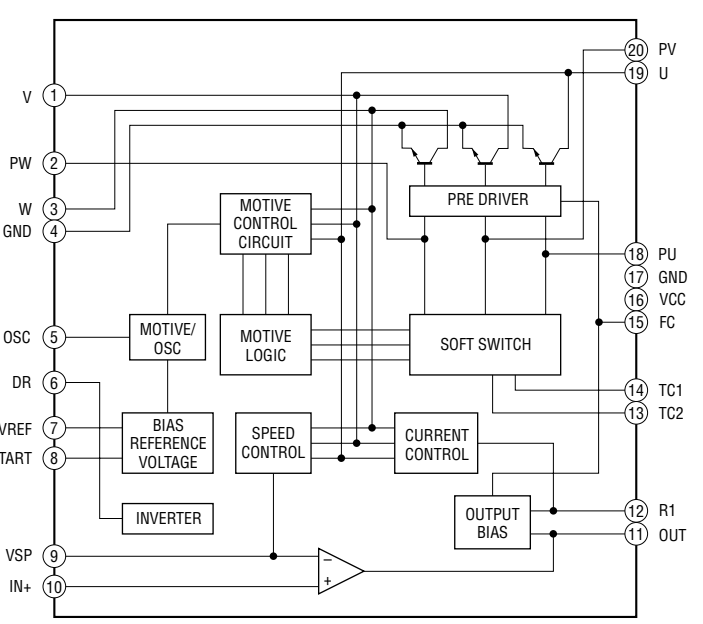

IC702 XC6371C251PL

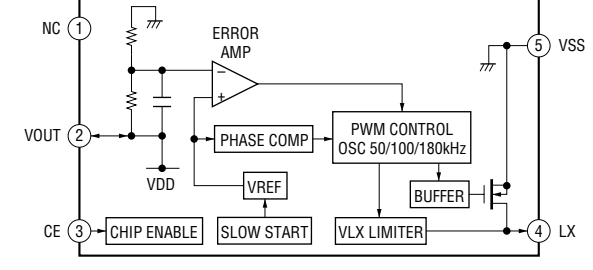

6-4. IC PIN FUNCTION DESCRIPTION

• IC701 uPD789166GB-510-8ES (SYSTEM CONTROLLER)

Pin No.	Pin Name	I/O	Description
1	BATT DET	I	Battery voltage detection signal input (A/D input)
2	KEY IN	I	Key input terminal (A/D input)
3	F/R SW	I	Tape direction switch (S701) input terminal "L": forward position
4	AMS IN	I	Whether a music is present or not from TA2123AF (IC301) is detected at auto music sensor "L": music is present, "H": music is not present
5	OSC IN	I	Motor restart control signal input from the capstan/reel motor drive (IC601) "L": FF/REW motor rotation status
6	NC	I	Not used (open)
7	DOLBY KEY CTL	I	Dolby is present or not control terminal "L": dolby is not present (WM-EX500), "H": dolby is present (WM-EX505)
8	PHOTO IN	I	Rotation detect signal input of the capstan/reel motor (M901)
9	AVSS	—	Ground terminal (for A/D converter)
10	PHOTO CTL	O	Control signal output to the capstan/reel motor rotation detect circuit "L": rotation detect circuit on
11	AMP CTL	O	Also, this is used as control signal output for power on/off to the TA2123AF (IC301), or power supply output for the dolby NR amp (IC302) "L": power off, "H": power on IC302: Used for the WM-EX505 only
12	WAKE UP	I	Input of acknowledge signal for the key entry Acknowledge signal is input to accept function in the power off status On at input of "H"
13	TAPE SW	I	Cassette tape detect switch (S901-1) input terminal "L": cassette detected, "H": no cassette
14	RMUM	I	Connection detect signal input of the remote commander
15	BEEP	O	Beep sound signal output to the TA2123AF (IC301)
16	F/R CTL	O	Forward/reverse selection signal output to the TA2123AF (IC301) "L": forward direction, "H": reverse direction
17	VDD1	—	Power supply terminal (+2.5V)
18	AVLS CTL	O	AVLS (Automatic Volume Limiter System) on/off control signal output terminal "L": AVLS off, "H": AVLS on
19	GRV/MB CTL	O	Emphasizing sound control signal output to the TA2123AF (IC301) "L": MB (mega bass), "H": normal/GRV (groove)
20	BST CTL	O	Bass boost control signal output to the TA2123AF (IC301) "L": off, "H": on
21	LED DOLBY	O	LED drive signal output of the NR indicator (D704) "L": LED on Used for the WM-EX505 only
22	IC0	—	Not used (fixed at "L")
23	XT2	O	Sub clock output terminal Not used (open)
24	XT1	I	Sub clock input terminal Not used (fixed at "L")
25	RESET	I	System reset signal input from the reset signal generator (IC703) "L": reset "L" is input for several 100 msec after power on, then it changes to "H"
26	X2	O	System clock output terminal (4MHz)
27	X1	I	System clock input terminal (4MHz)
28	VSS0	—	Ground terminal
29	VDD0	—	Power supply terminal (+2.5V)
30	R DATA OUT	O	Communication serial data output to the remote commander
31	LED BATT	O	LED drive signal output of the BATT indicator (D703) "H": LED on
32	DOLBY CTL	O	Dolby on/off control signal output to the dolby NR amp (IC302) "L": dolby NR on, "H": dolby NR off Used for the WM-EX505 only
33	MOTOR CTL	O	Motor start control signal output to the capstan/reel motor drive (IC601) "L": motor off, "H": motor on

Pin No.	Pin Name	I/O	Description
34	MOTOR DIR	O	Motor direction control signal output to the capstan/reel motor drive (IC601) “L”: counterclockwise, “H”: clockwise
35	SPEED CTL	O	Motor speed control signal output to the capstan/reel motor drive (IC601) “L”: normal speed, “H”: 1/2 speed
36	MUTE	O	Power on mute control signal output to the TA2123FA (IC301) “L”: mute on
37	VSS1	—	Ground terminal
38	PM CTL	O	Plunger drive signal output terminal “L”: plunger on
39	LED AVLS	O	LED drive signal output of the AVLS indicator (D705) “L”: LED on
40	LED BL SKIP	O	LED drive signal output of the BL SKIP/↺ indicator (D706) “L”: LED on
41, 42	NC	—	Not used (open)
43	AVDD	—	Power supply terminal (+2.5V) (for A/D converter)
44	AVREF	I	Reference voltage input terminal (+2.5V) (for A/D converter)

SECTION 7 EXPLODED VIEWS

NOTE:

- -XX and -X mean standardized parts, so they may have some difference from the original one.
- Color Indication of Appearance Parts
Example:
KNOB, BALANCE (WHITE) . . . (RED)
 ↑ ↑
 Parts Color Cabinet's Color

- Items marked “*” are not stocked since they are seldom required for routine service. Some delay should be anticipated when ordering these items.
- The mechanical parts with no reference number in the exploded views are not supplied.
- Accessories and packing materials are given in the last of the electrical parts list.

(1) CASE SECTION

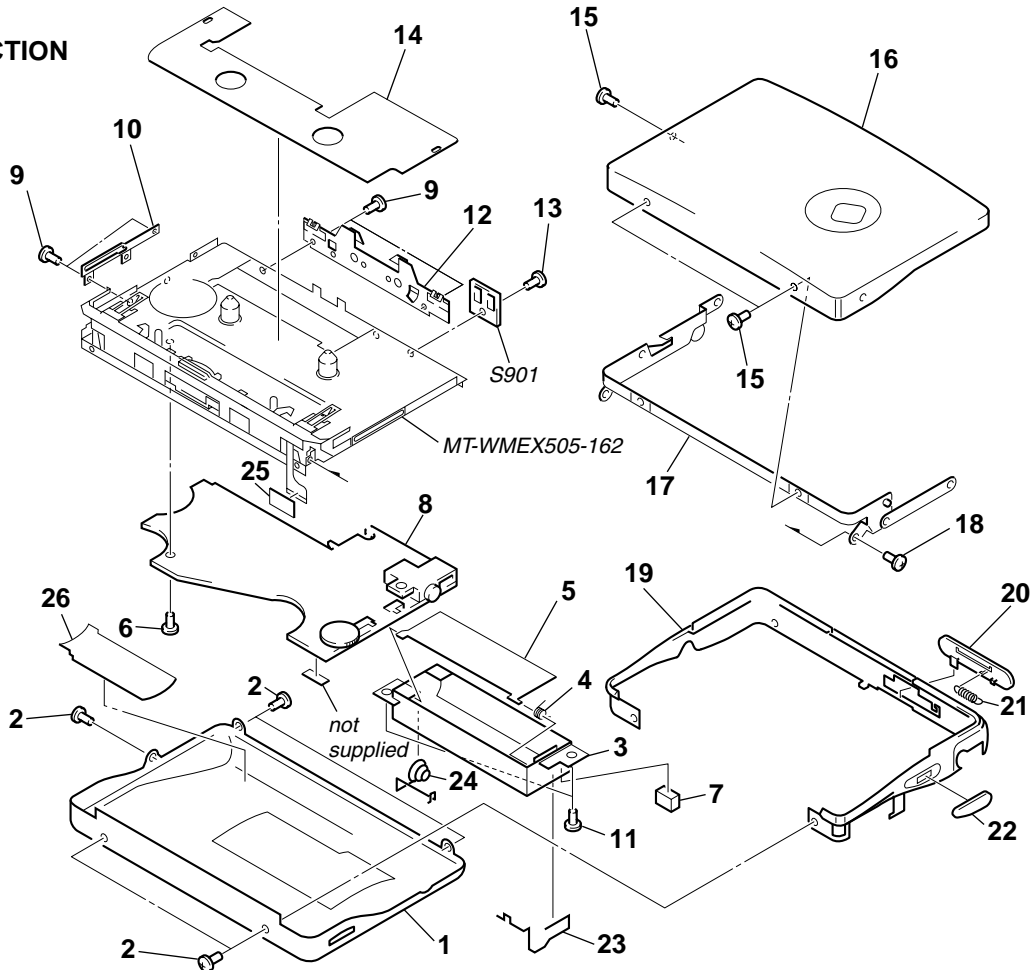

Ref. No.	Part No.	Description	Remark	Ref. No.	Part No.	Description	Remark
1	X-3378-883-1	LID ASSY (SV-S-C), CASSETTE		12	X-3377-717-1	BRACKET ASSY (/M)	
		(SILVER) (EX500)		13	3-939-590-02	SCREW (IB LOCK)	
1	X-3378-884-1	LID ASSY (SV-L-C), CASSETTE		14	3-042-015-01	COVER, MD (EX500)	
		(BLUE) (EX500)		14	3-042-015-11	COVER, MD (EX505)	
1	X-3378-885-1	LID ASSY (SV-N-C), CASSETTE		15	3-704-197-11	SCREW (M1.4X2.0), LOCKING	
		(GOLD) (EX505)				(SILVER)...(SILVER, GOLD)	
2	3-704-197-31	SCREW (M1.4X3.0), LOCKING		15	3-704-197-13	SCREW (M1.4X2.0), LOCKING	
		(SILVER)...(SILVER, GOLD)				(BLACK)...(BLUE)	
2	3-704-197-33	SCREW (M1.4X3.0), LOCKING		16	X-3378-898-1	CASE ASSY (SV-S) (SILVER) (EX500)	
		(BLACK)...(BLUE)		16	X-3378-899-1	CASE ASSY (SV-L) (BLUE) (EX500)	
3	3-042-001-01	HOLDER, BATTERY		16	X-3378-900-1	CASE ASSY (SV-N) (GOLD) (EX505)	
4	3-042-003-01	SPRING		17	X-3376-279-1	BRACKET (CASSETTE) ASSY	
5	3-042-002-01	LID, BATTERY CASE		18	3-365-630-41	SCREW (M1.4)	
6	3-345-648-95	SCREW (M1.4), TOOTHED LOCK		19	3-042-006-01	ORNAMENT, REEL	
7	3-047-460-01	CUSHION (C)		20	3-042-007-01	KNOB (OPEN)	
8	A-3021-284-A	MAIN BOARD, COMPLETE		21	3-042-008-01	SPRING, TENSION	
		(EX505: EXCEPT FRENCH)		22	3-042-009-01	KNOB (HOLD)	
8	A-3021-286-A	MAIN BOARD, COMPLETE		23	3-042-004-01	TERMINAL (+), BATTERY	
		(EX505: FRENCH)		24	3-042-005-01	TERMINAL (-), BATTERY	
8	A-3021-287-A	MAIN BOARD, COMPLETE		25	3-309-595-11	SHEET, INSULATING, PACK	
		(EX500: EXCEPT FRENCH)		26	3-044-951-01	SHEET (A)	
8	A-3021-288-A	MAIN BOARD, COMPLETE (EX500: FRENCH)		S901	1-771-888-11	SWITCH, LEAF (TAPE DETECT)	
9	3-939-590-05	SCREW (IB LOCK)					
10	3-029-217-01	LEVER (B), LOCK					
11	3-375-114-81	SCREW					

(2) MECHANISM DECK SECTION
(MT-WMEX505-162)

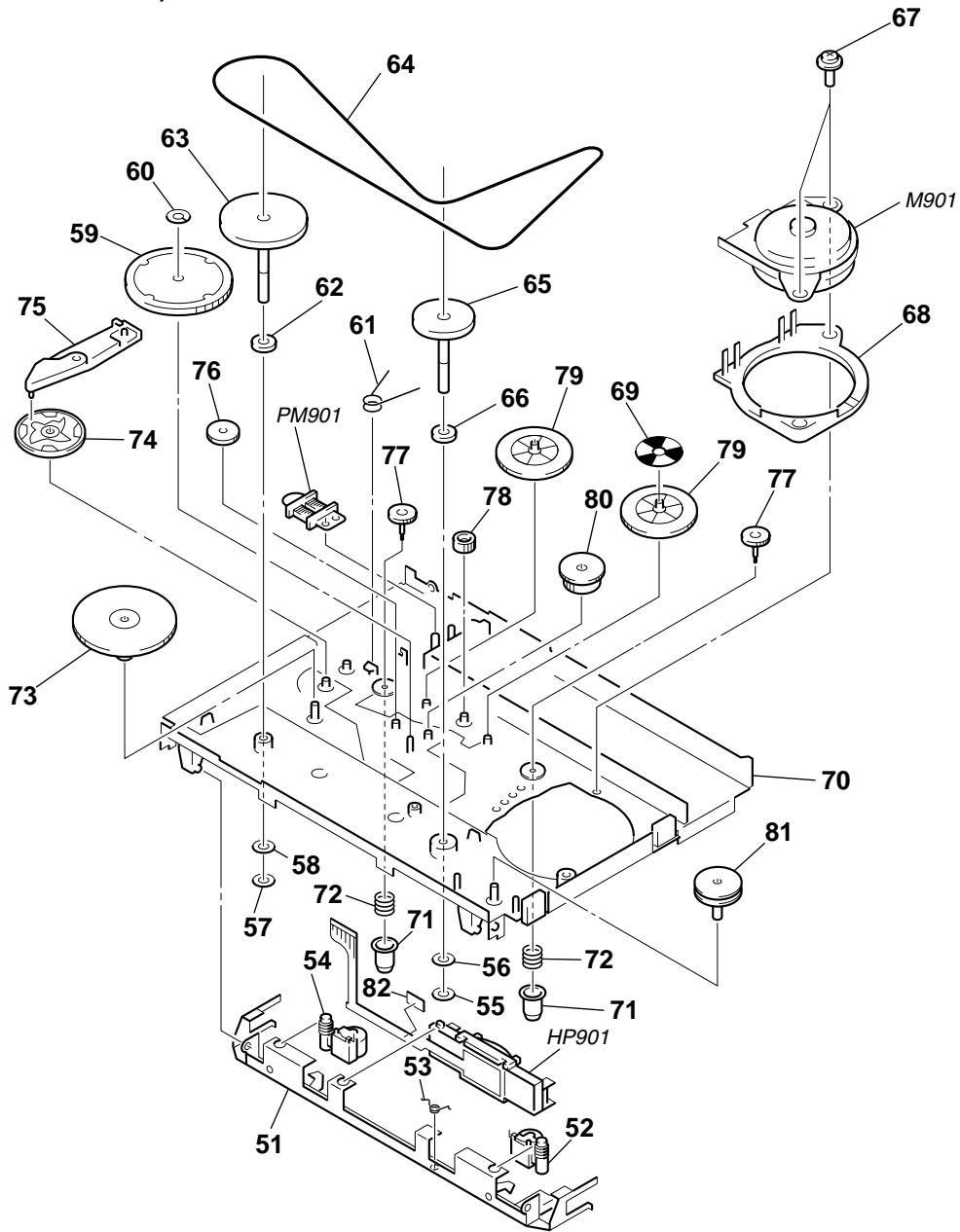

Ref. No.	Part No.	Description	Remark	Ref. No.	Part No.	Description	Remark
51	X-3378-354-1	HOLDER (FS) ASSY		69	3-007-433-01	SHEET (N), REFLECTION	
52	X-3377-363-1	LEVER (R) ASSY, PINCH		70	X-3378-107-1	CHASSIS (FB) ASSY	
53	3-046-789-01	SPRING (HDA)		71	3-010-274-02	TABLE, REEL	
54	X-3377-362-1	LEVER (N) ASSY, PINCH		72	3-010-954-01	SPRING (BT), COMPRESSION	
55	3-029-275-01	WASHER (STOPPER N)		73	3-029-282-01	GEAR (Y)	
56	3-029-278-01	WASHER		74	3-029-285-01	GEAR, CAM	
57	3-029-276-01	WASHER (STOPPER R)		75	3-029-284-01	LEVER, TRIGGER	
58	3-029-289-01	WASHER		76	3-029-281-01	GEAR, IDLER (B)	
59	X-3376-813-1	CLUTCH ASSY (F)		77	3-010-273-02	GEAR (REEL)	
60	3-932-724-21	WASHER		78	3-029-273-01	GEAR (FR)	
61	3-040-897-01	SPRING (TGA), TORSION		79	3-029-283-01	GEAR, IDLER (A)	
62	3-386-694-01	WASHER		80	3-029-286-01	GEAR (NR)	
63	3-029-306-11	FLYWHEEL (N), INSERT		81	3-029-288-01	PULLEY, REVERSE	
64	3-029-280-01	BELT (F2)		82	3-033-757-01	SHEET (H)	
65	3-029-268-11	FLYWHEEL (R), INSERT		HP901	1-500-576-11	HEAD, MAGNETIC (PLAYBACK)	
66	3-007-428-01	WASHER (R)		M901	1-763-166-11	MOTOR (CAPSTAN/REEL) (WITH PULLEY)	
67	3-029-765-01	SCREW (M1.4), TOOTHED LOCK		PM901	1-454-674-41	SOLENOID, PLUNGER	
68	3-029-274-11	RETAINER (F2), MOTOR					

SECTION 8 ELECTRICAL PARTS LIST

NOTE:

- Due to standardization, replacements in the parts list may be different from the parts specified in the diagrams or the components used on the set.
- -XX and -X mean standardized parts, so they may have some difference from the original one.
- RESISTORS
All resistors are in ohms.
METAL: Metal-film resistor.
METAL OXIDE: Metal oxide-film resistor.
F: nonflammable
- Abbreviation
9E: No indication of country of origin
EE: East European

- Items marked “*” are not stocked since they are seldom required for routine service. Some delay should be anticipated when ordering these items.
- SEMICONDUCTORS
In each case, u: μ , for example:
uA. . : μ A. . uPA. . : μ PA. .
uPB. . : μ PB. . uPC. . : μ PC. .
uPD. . : μ PD. .
- CAPACITORS
uF: μ F
- COILS
uH: μ H

When indicating parts by reference number, please include the board.

Ref. No.	Part No.	Description	Remark	Ref. No.	Part No.	Description	Remark
	A-3021-284-A	MAIN BOARD, COMPLETE (EX505: EXCEPT FRENCH)		C314	1-135-187-21	TANTALUM CHIP 2.2uF	20% 4V
	A-3021-286-A	MAIN BOARD, COMPLETE (EX505: FRENCH)		C316	1-125-837-11	CERAMIC CHIP 1uF	10% 6.3V
	A-3021-287-A	MAIN BOARD, COMPLETE (EX500: EXCEPT FRENCH)		C317	1-162-964-11	CERAMIC CHIP 0.001uF	10% 50V (EX505)
	A-3021-288-A	MAIN BOARD, COMPLETE (EX500: FRENCH) ***** < CAPACITOR >		C318	1-135-201-11	TANTALUM CHIP 10uF	20% 4V (EX505)
C101	1-107-520-11	TANTALUM CHIP 33uF	20% 2.5V	C319	1-164-156-11	CERAMIC CHIP 0.1uF	25V
C102	1-115-156-11	CERAMIC CHIP 1uF	10V	C320	1-162-968-11	CERAMIC CHIP 0.0047uF	10% 50V
C103	1-115-156-11	CERAMIC CHIP 1uF	10V	C321	1-115-416-11	CERAMIC CHIP 1000PF	5% 25V
C104	1-115-156-11	CERAMIC CHIP 1uF	10V	C322	1-125-899-11	TANTALUM CHIP 220uF	20% 4V
C105	1-117-863-11	CERAMIC CHIP 0.47uF	10% 6.3V (EX505)	C323	1-115-412-11	CERAMIC CHIP 680PF	5% 25V
C106	1-115-467-11	CERAMIC CHIP 0.22uF	10% 10V (EX505)	C601	1-125-837-11	CERAMIC CHIP 1uF	10% 6.3V
C107	1-164-505-11	CERAMIC CHIP 2.2uF	16V	C602	1-107-826-11	CERAMIC CHIP 0.1uF	10% 16V
C108	1-164-227-11	CERAMIC CHIP 0.022uF	10% 25V	C603	1-115-467-11	CERAMIC CHIP 0.22uF	10% 10V
C109	1-164-677-11	CERAMIC CHIP 0.033uF	10% 16V	C604	1-164-156-11	CERAMIC CHIP 0.1uF	25V
C133	1-164-227-11	CERAMIC CHIP 0.022uF	10% 25V	C605	1-107-826-11	CERAMIC CHIP 0.1uF	10% 16V
C201	1-107-520-11	TANTALUM CHIP 33uF	20% 2.5V	C606	1-162-970-11	CERAMIC CHIP 0.01uF	10% 25V
C202	1-115-156-11	CERAMIC CHIP 1uF	10V	C607	1-162-970-11	CERAMIC CHIP 0.01uF	10% 25V
C203	1-115-156-11	CERAMIC CHIP 1uF	10V	C608	1-162-970-11	CERAMIC CHIP 0.01uF	10% 25V
C204	1-115-156-11	CERAMIC CHIP 1uF	10V	C701	1-119-750-11	TANTALUM CHIP 22uF	20% 6.3V
C205	1-117-863-11	CERAMIC CHIP 0.47uF	10% 6.3V (EX505)	C702	1-104-851-11	TANTALUM CHIP 10uF	20% 10V
C206	1-115-467-11	CERAMIC CHIP 0.22uF	10% 10V (EX505)	C703	1-162-964-11	CERAMIC CHIP 0.001uF	10% 50V
C207	1-164-505-11	CERAMIC CHIP 2.2uF	16V	C708	1-115-156-11	CERAMIC CHIP 1uF	10V
C208	1-164-227-11	CERAMIC CHIP 0.022uF	10% 25V	C709	1-115-156-11	CERAMIC CHIP 1uF	10V
C209	1-164-677-11	CERAMIC CHIP 0.033uF	10% 16V	C710	1-115-156-11	CERAMIC CHIP 1uF	10V (EX505)
C233	1-164-227-11	CERAMIC CHIP 0.022uF	10% 25V	C711	1-115-156-11	CERAMIC CHIP 1uF	10V
C301	1-119-663-11	TANTALUM CHIP 47uF	20% 2.5V	< COMPOSITION CIRCUIT BLOCK >			
C302	1-164-156-11	CERAMIC CHIP 0.1uF	25V	CB301	1-127-575-21	CERAMIC CHIP 470PF	50V
C303	1-117-181-11	TANTALUM CHIP 4.7uF	20% 2.5V	< DIODE >			
C304	1-115-156-11	CERAMIC CHIP 1uF	10V	D701	8-719-073-01	DIODE MA111-(K8).S0	
C305	1-126-236-11	ELECT 330uF	20% 2V	D702	8-719-072-70	DIODE MA2ZD14001S0	
C306	1-109-935-11	TANTALUM CHIP 4.7uF	20% 4V	D703	8-719-077-09	LED CL-196HR-CD-T (BATT)	
C307	1-115-467-11	CERAMIC CHIP 0.22uF	10% 10V	D704	8-719-077-09	LED CL-196HR-CD-T (□ NR) (EX505)	
C308	1-165-112-11	CERAMIC CHIP 0.33uF	16V	D705	8-719-077-09	LED CL-196HR-CD-T (AVLS)	
C309	1-115-467-11	CERAMIC CHIP 0.22uF	10% 10V	D706	8-719-077-09	LED CL-196HR-CD-T (BL SKIP↻)	
C310	1-135-149-21	TANTALUM CHIP 2.2uF	20% 10V	D709	8-719-068-83	DIODE MAZL068D0LS0-TX/L	
C311	1-164-156-11	CERAMIC CHIP 0.1uF	25V	D710	8-719-422-58	DIODE MA8062	
C312	1-115-156-11	CERAMIC CHIP 1uF	10V	D711	8-719-422-58	DIODE MA8062	
C313	1-109-935-11	TANTALUM CHIP 4.7uF	20% 4V				

Ref. No.	Part No.	Description	Remark	Ref. No.	Part No.	Description	Remark
		< FERRITE BEAD >		R114	1-216-821-11	METAL CHIP	1K 5% 1/16W
FB101	1-469-125-21	FERRITE BEAD (EXCEPT FRENCH)		R150	1-216-807-11	RES, CHIP	68 5% 1/16W
FB201	1-469-125-21	FERRITE BEAD (EXCEPT FRENCH)					(FRENCH)
		< IC >		R201	1-216-849-11	METAL CHIP	220K 5% 1/16W
IC301	8-759-579-12	IC TA2123AF (EL)		R202	1-216-839-11	METAL CHIP	33K 5% 1/16W
IC302	8-759-488-80	IC NJM2185AV-TE2 (EX505)		R203	1-216-811-11	METAL CHIP	150 5% 1/16W
IC601	8-759-356-46	IC MM1279XVBE		R204	1-216-831-11	METAL CHIP	6.8K 5% 1/16W
IC701	8-759-651-61	IC uPD789166GB-510-8ES		R205	1-216-823-11	METAL CHIP	1.5K 5% 1/16W
IC702	8-759-566-77	IC XC6371C251PL		R206	1-216-825-11	METAL CHIP	2.2K 5% 1/16W
				R207	1-216-837-11	METAL CHIP	22K 5% 1/16W
IC703	8-759-665-68	IC PST9016NL		R208	1-216-789-11	METAL CHIP	2.2 5% 1/16W
IC704	8-759-387-31	IC TC75S55F (TE85R)		R210	1-216-837-11	METAL CHIP	22K 5% 1/16W
							(EX505)
		< JACK >		R211	1-216-827-11	METAL CHIP	3.3K 5% 1/16W
J301	1-779-867-81	JACK (☺ REMOTE)		R212	1-216-809-11	METAL CHIP	100 5% 1/16W
							(EXCEPT FRENCH)
		< RESISTOR >		R212	1-216-821-11	METAL CHIP	1K 5% 1/16W
JC101	1-216-864-11	METAL CHIP	0 5% 1/16W				(EX500: FRENCH)
				R212	1-216-825-11	METAL CHIP	2.2K 5% 1/16W
JC201	1-216-864-11	METAL CHIP	0 5% 1/16W				(EX505: FRENCH)
				R213	1-216-853-11	METAL CHIP	470K 5% 1/16W
JC701	1-216-864-11	METAL CHIP	0 5% 1/16W				(EX505: FRENCH)
				R214	1-216-821-11	METAL CHIP	1K 5% 1/16W
JC702	1-216-864-11	METAL CHIP	0 5% 1/16W	R250	1-216-807-11	RES, CHIP	68 5% 1/16W
							(FRENCH)
				R301	1-218-887-11	METAL CHIP	47K 0.5% 1/16W
							(EX505)
		< COIL >		R302	1-216-849-11	METAL CHIP	220K 5% 1/16W
L701	1-412-032-11	INDUCTOR CHIP 100uH		R303	1-216-833-11	RES, CHIP	10K 5% 1/16W
		< PHOTO INTERRUPTER >		R304	1-216-835-11	METAL CHIP	15K 5% 1/16W
PH701	8-749-014-43	PHOTO INTERRUPTER PR-20-T		R305	1-216-837-11	METAL CHIP	22K 5% 1/16W
				R306	1-216-793-11	RES, CHIP	4.7 5% 1/16W
				R307	1-216-825-11	METAL CHIP	2.2K 5% 1/16W
				R308	1-216-851-11	METAL CHIP	330K 5% 1/16W
		< TRANSISTOR >		R309	1-218-899-11	METAL CHIP	150K 0.5% 1/16W
Q301	8-729-800-71	TRANSISTOR 2SB815B7-TB					(EX505)
Q303	8-729-924-04	TRANSISTOR DTA143TU		R601	1-216-837-11	METAL CHIP	22K 5% 1/16W
Q304	8-729-421-23	TRANSISTOR XN1216		R602	1-216-809-11	METAL CHIP	100 5% 1/16W
Q701	8-729-230-72	TRANSISTOR 2SA1362YG		R603	1-216-829-11	METAL CHIP	4.7K 5% 1/16W
Q702	8-729-420-50	TRANSISTOR UN5215		R604	1-216-823-11	METAL CHIP	1.5K 5% 1/16W
		< RESISTOR >		R605	1-216-833-11	RES, CHIP	10K 5% 1/16W
R101	1-216-849-11	METAL CHIP	220K 5% 1/16W	R622	1-216-849-11	METAL CHIP	220K 5% 1/16W
R102	1-216-839-11	METAL CHIP	33K 5% 1/16W	R623	1-216-849-11	METAL CHIP	220K 5% 1/16W
R103	1-216-811-11	METAL CHIP	150 5% 1/16W	R624	1-216-849-11	METAL CHIP	220K 5% 1/16W
R104	1-216-831-11	METAL CHIP	6.8K 5% 1/16W	R701	1-216-823-11	METAL CHIP	1.5K 5% 1/16W
R105	1-216-823-11	METAL CHIP	1.5K 5% 1/16W				
				R702	1-216-855-11	METAL CHIP	680K 5% 1/16W
R106	1-216-825-11	METAL CHIP	2.2K 5% 1/16W	R703	1-216-853-11	METAL CHIP	470K 5% 1/16W
R107	1-216-837-11	METAL CHIP	22K 5% 1/16W	R704	1-216-853-11	METAL CHIP	470K 5% 1/16W
R108	1-216-789-11	METAL CHIP	2.2 5% 1/16W	R705	1-216-821-11	METAL CHIP	1K 5% 1/16W
R110	1-216-837-11	METAL CHIP	22K 5% 1/16W	R706	1-216-843-11	METAL CHIP	68K 5% 1/16W
				R707	1-218-911-11	METAL CHIP	470K 0.5% 1/16W
R111	1-216-827-11	METAL CHIP	3.3K 5% 1/16W	R708	1-218-863-11	METAL CHIP	4.7K 0.5% 1/16W
				R710	1-216-853-11	METAL CHIP	470K 5% 1/16W
R112	1-216-809-11	METAL CHIP	100 5% 1/16W	R711	1-216-853-11	METAL CHIP	470K 5% 1/16W
				R712	1-216-853-11	METAL CHIP	470K 5% 1/16W
R112	1-216-821-11	METAL CHIP	1K 5% 1/16W	R713	1-216-847-11	METAL CHIP	150K 5% 1/16W
				R714	1-216-803-11	METAL CHIP	33 5% 1/16W
				R715	1-216-821-11	METAL CHIP	1K 5% 1/16W
R112	1-216-825-11	METAL CHIP	2.2K 5% 1/16W	R716	1-216-821-11	METAL CHIP	1K 5% 1/16W
							(EX505)
R113	1-216-853-11	METAL CHIP	470K 5% 1/16W				

MAIN

Ref. No.	Part No.	Description	Remark
R717	1-216-849-11	METAL CHIP 220K	5% 1/16W
R718	1-216-821-11	METAL CHIP 1K	5% 1/16W
R719	1-216-809-11	METAL CHIP 100	5% 1/16W (EX505)
R720	1-218-871-11	METAL CHIP 10K	0.5% 1/16W
R721	1-218-839-11	METAL CHIP 470	0.5% 1/16W
R722	1-218-855-11	METAL CHIP 2.2K	0.5% 1/16W
R723	1-218-851-11	METAL CHIP 1.5K	0.5% 1/16W
R724	1-218-859-11	METAL CHIP 3.3K	0.5% 1/16W
R725	1-218-859-11	METAL CHIP 3.3K	0.5% 1/16W
R726	1-216-821-11	METAL CHIP 1K	5% 1/16W
R727	1-216-821-11	METAL CHIP 1K	5% 1/16W
R728	1-216-821-11	METAL CHIP 1K	5% 1/16W
R731	1-216-857-11	METAL CHIP 1M	5% 1/16W
R732	1-216-849-11	METAL CHIP 220K	5% 1/16W
R733	1-218-895-11	METAL CHIP 100K	0.5% 1/16W
R734	1-218-851-11	METAL CHIP 1.5K	0.5% 1/16W
R735	1-218-871-11	METAL CHIP 10K	0.5% 1/16W
R736	1-218-867-11	METAL CHIP 6.8K	0.5% 1/16W
R737	1-218-875-11	METAL CHIP 15K	0.5% 1/16W
R738	1-218-859-11	METAL CHIP 3.3K	0.5% 1/16W
R739	1-216-847-11	METAL CHIP 150K	5% 1/16W
R740	1-216-847-11	METAL CHIP 150K	5% 1/16W
R750	1-216-845-11	METAL CHIP 100K	5% 1/16W
< VARIABLE RESISTOR >			
RV301	1-227-167-21	RES, VAR, CARBON 30K/30K (VOL)	
RV601	1-223-576-11	RES, ADJ, METAL GLAZE 2.2K	
< SWITCH >			
S701	1-771-475-21	SWITCH, SLIDE (DIRECTION)	
S702	1-771-851-21	SWITCH, TACTILE (SMD) (■)	
S703	1-771-851-21	SWITCH, TACTILE (SMD) (◀▶ REPEAT)	
S704	1-771-851-21	SWITCH, TACTILE (SMD) (FF AMS)	
S705	1-771-851-21	SWITCH, TACTILE (SMD) (REW AMS)	
S706	1-771-851-21	SWITCH, TACTILE (SMD) (SOUND)	
S707	1-572-922-11	SWITCH, SLIDE (HOLD)	
S708	1-771-851-21	SWITCH, TACTILE (SMD) (FUNCTION)	
< THERMISTOR (POSITIVE) >			
THP601	1-810-794-11	THERMISTOR, POSITIVE	
< VIBRATOR >			
X701	1-767-289-11	VIBRATOR, CERAMIC (4MHz)	

MISCELLANEOUS			

HP901	1-500-576-12	HEAD, MAGNETIC (PLAYBACK)	
M901	1-763-166-14	MOTOR (CAPSTAN/REEL) (WITH PULLEY)	
PM901	1-454-674-41	SOLENOID, PLUNGER	
S901	1-771-888-11	SWITCH, LEAF (TAPE DETECT)	

Ref. No.	Part No.	Description	Remark
		ACCESSORIES & PACKING MATERIALS	

3-868-001-11		MANUAL, INSTRUCTION (ENGLISH, FRENCH, SPANISH, PORTUGUESE, ITALIAN) (EX505: AEP, FRENCH)	
3-868-001-21		MANUAL, INSTRUCTION (GERMAN, DUTCH, SWEDISH, FINNISH) (EX505: AEP)	
3-868-001-31		MANUAL, INSTRUCTION (ENGLISH, CHINESE) (EX505: 9E)	
3-868-002-11		MANUAL, INSTRUCTION (ENGLISH, FRENCH, SPANISH, PORTUGUESE, GERMAN, ITALIAN, DUTCH, SWEDISH, FINNISH) (EX500: EXCEPT EE)	
3-868-002-21		MANUAL, INSTRUCTION (ENGLISH, HUNGARIAN, POLISH, RUSSIAN, CZECH, SLOVAKIAN) (EX500: EE)	
8-953-130-90		HEADPHONE MDR-E805LP (EX500)	
8-953-304-90		RECEIVER MDR-E805SP (EX505)	
A-3052-138-A		REMOTE CONTROL ASSY (RM-WME5) (EX505)	