

WM-EX50/FX50

SERVICE MANUAL



WM-EX50



WM-FX50

US Model
AEP Model
E Model
WM-EX50/FX50

UK Model
WM-EX50

Canadian Model
WM-FX50

TABLE OF CONTENTS

GENERAL	2-6
Messages, warnings and tips.....	2
Test equipment, Jigs and material	3
Feature	3
Location and function of controls	4
User's instruction (WM-EX50 only).....	5-6
Service notes	6
REMOVAL	7
LCD BLOCK INFORMATION(WM-EX50 only)....	8
Data code chart and indication mode	8
BLOCK DIAGRAMS	9-10
SCHEMATICS AND BOARD DIAGRAMS	11-19
Semiconductor layouts	14
IC layouts	19
SPARE PARTS LIST	20-28
Exploded views and mechanical parts.....	20-22
Electrical parts	23-28
ADJUSTMENTS	29-32
Mechanical measurements	29
Mechanical adjustments.....	29
Electrical alignments	30-32
Adjustment location	29-30
SPECIFICATIONS	34

Model Name Using Similar Mechanism	WM-2091 WM-F2095
Tape Transport Mechanism	WM-EX50 : MT-WMEX50-01
	WM-FX50 : MT-WMFX50-01

Dolby noise reduction manufactured under license from Dolby Laboratories Licensing Corporation. "DOLBY" and the double-D symbol  are trademarks of Dolby Laboratories Licensing Corporation.

CASSETTE PLAYER

WM-EX50

RADIO CASSETTE PLAYER

WM-FX50

SONY®

GENERAL

Messages, warnings and tips

CAUTION

Danger of explosion if battery is incorrectly replaced. Replace only with the same or equivalent type recommended by the equipment manufacturer. Discard used batteries according to manufacture's instructions.

ADVARSEL!

Lithiumbatteri - Eksplosionsfare ved fejlagtig håndtering.
Udskiftning må kun ske med batteri
af samme fabrikat og type.
Lever det brugte batteri tilbage til leverandøren.

ADVARSEL

Lithiumbatteri - Eksplosjonsfare.
Ved utskifting benyttes kun batteri som
anbefalt av apparatfabrikanten.
Brukt batteri returneres apparatleverandøren.

VARNING

Explosionsfara vid felaktigt batteribyte.
Använd samma batterityp eller en ekvivalent
typ som rekommenderas av apparattillverkaren.
Kassera använt batteri enligt fabrikantens
instruktion.

VAROITUS

Paristo voi räjähtää, jos se on virheellisesti asennettu.
Vaihda paristo ainoastaan laitevalmistajan suosittelemaan
tyyppiin. Hävitä käytetty paristo valmistajan ohjeiden
mukaisesti.

SAFETY-RELATED COMPONENT

WARNING!!

COMPONENTS IDENTIFIED BY MARK \triangle OR
DOTTED LINE WITH MARK \triangle ON THE
SCHEMATIC DIAGRAMS AND IN THE PARTS
LIST ARE CRITICAL TO SAFE OPERATION.
REPLACE THESE COMPONENTS WITH SONY
PARTS WHOSE PART NUMBERS APPEAR AS
SHOWN IN THIS MANUAL OR IN SUPPLEMENTS
PUBLISHED BY SONY.

ATTENTION AU COMPOSANT AYANT RAPPORT À LA SÉCURITÉ!

LES COMPOSANTS IDENTIFIÉS PAR UNE
MARQUE \triangle SUR LES DIAGRAMMES SCHÉ-
MATIQUES ET LA LISTE DES PIÈCES SONT
CRITIQUES POUR LA SÉCURITÉ DE FONCTION-
NEMENT. NE REMPLACER CES COMPOSANTS
QUE PAR DES PIÈCES SONY DONT LES
NUMÉROS SONT DONNÉS DANS CE MANUEL OU
DANS LES SUPPLÉMENTS PUBLIÉS PAR SONY.

Precautions

Notes on battery

- Remove the battery when you will not use the unit for a long time to prevent damage from battery leakage and corrosion.
- When the sound becomes unstable, try a new battery.

External power sources

The following external power sources can be connected through the DC IN 1.5V jack.

- House current using an AC-E15L AC power adaptor.

The illustration shows the polarity of DC IN 1.5V jack. Use only a power cord having the same polarity.



Test equipment, Jigs and Material

Test equipment

Digital multimeter
 FM RF signal generator
 AM RF signal generator
 Stabilized power supply
 Speed checker
 Wow and Flutter
 Frequency counter
 VTVM
 Spectrum analyzer
 SONY Digital tuning radio ICF-2001 or equivalents

Jigs

Test tape	Part Number
- WS-48A (3kHz, 0dB)	7-819-032-11
Cassette type torque meter	
- CQ-102C (normal direction)	8-909-708-22
- CQ-102RC (reverse direction)	8-909-708-26
- CQ-201B (FF and REW)	8-909-708-41
Cassette type Tension meter	
- CQ-403A (normal direction)	8-909-708-92
- CQ-403R (reverse direction)	8-909-708-95

Screw locking compound

Neji lock G (1401B)	7-432-114-11
---------------------	--------------

Greases and Oil

Machine oil Hydro Fluid NT-68	7-661-018-18
Sankol FG-84M	7-662-001-36

Feature

• Double Super heterodyne FM receiver for

WM-FX50

The FM receiver is used the double super heterodyne system which is superior in FM sensitivity and image spurious rejection.

System comparison chart

	WM-FX50	WM-F702
Receiving system	Double super heterodyne (FM)	Single super heterodyne
Detector	Double pulse count	Quadrature
AM IF	55kHz	450kHz
FM IF	28.6MHz (1st IF) 150kHz (2nd IF)	10.7MHz
Filter element	Monolitic	Ceramic

Method of calculation

NOTE : f_s = Tuned frequency

• FM local oscillator frequency

1st stage local oscillator frequency (f_o)

$$f_o = f_s + \left(\frac{2nd \text{ local OSC}}{2} \right) - 150kHz$$

[For Example]

Tuned at 100MHz

$$f_o = 100 + \left(\frac{57.5}{2} \right) - 150kHz = 128.6MHz$$

2nd stage local oscillator frequency

57.5MHz (fixed)

• FM image frequency

$$f_{oi1} = f_s + \left(\frac{57.5MHz}{2} - 150kHz \right) \times 2$$

$$f_{oi2} = \frac{57.5MHz}{2} + 150kHz = 28.9MHz$$

[For Example]

Tuned at 100MHz

$$f_{oi1} = 100MHz + \left(\frac{57.5MHz}{2} - 150kHz \right) \times 2$$

$$= 157.2MHz$$

$$f_{oi2} = 28.9MHz \text{ (Fixed)}$$

• AM local oscillator frequency (f_o)

$$f_o = (f_s + 55kHz) \times 2$$

[For Example]

Tuned at 1000kHz

$$f_o = (1000kHz + 55kHz) \times 2 = 2110kHz$$

• AM image frequency (f_{oi})

$$f_{oi} = f_s + 55kHz \times 2$$

[For Example]

Tuned at 1000kHz

$$f_{oi} = 1000kHz + 55kHz \times 2 = 1110kHz$$

Location and Function of Controls

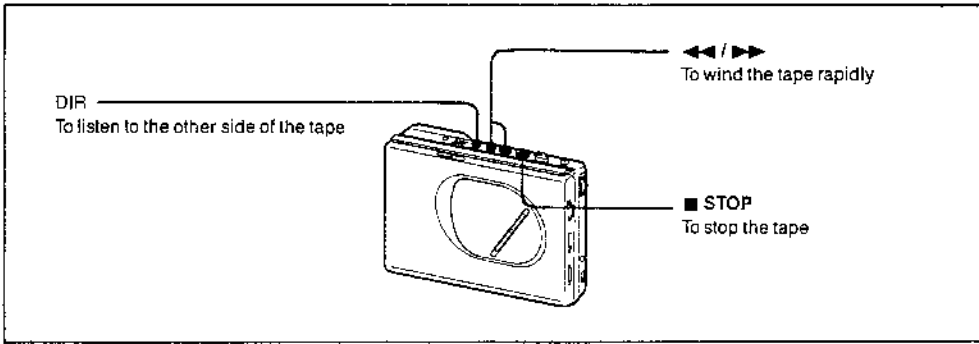

MEGA BASS
Listening to powerful and heavy sound

Set MEGA BASS to the desired position. Bass is boosted in the order of NORM, MID and MAX.

While playing back hard and stressed sound with MEGA BASS set to MAX, the sound may be distorted. In this case, set MEGA BASS to NORM or MID.

DOLBY NR
Getting the best performance from your tape

For Dolby NR processed tapes

MODE
On playback operation

Playing back both sides of the cassette once When the playback starts from the reverse side of the cassette, the unit will be shut off at the end of that side.	
Playing back both sides of the cassette repeatedly	

TAPE

For normal (TYPE I) tapes	
For CrO ₂ (TYPE II) or metal (TYPE IV) tapes	

MW-FX50 ONLY

For normal reception		For normal reception	
If a very strong station signal causes noise The noise will be reduced.		If it is hard to hear the broadcast due to noise, the noise will be reduced. In this mode, there is no stereo effect.	

User's Instruction

Setting the Clock

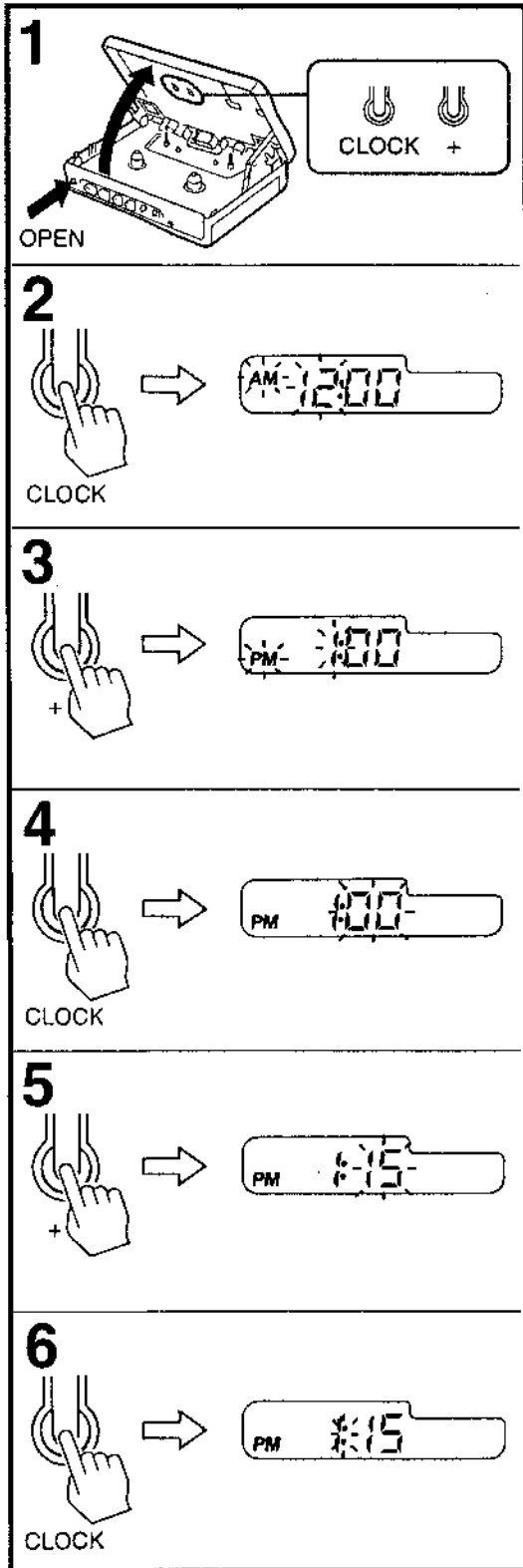

Before setting the clock, be sure that the clock indication appears in the LCD display window.
Ex. To set to 1:15 p.m.

- 1 Press the **OPEN** button.
- 2 Press the **CLOCK** button for 1.5 seconds or more.
- 3 Set the hour.
Press the + button repeatedly until you get the desired setting.
- 4 Press the **CLOCK** button.
- 5 Set the minute.
Press the + button repeatedly until you get the desired setting.
- 6 Press the **CLOCK** button.

Notes

- The hour display is in the 12-hour system.
- If you keep pressing the + button, the digits advance in sequence.
- The hour display does not advance even when the minute indication returns to "00" after "59".

To change the hour only

Follow steps 1 - 3, then press the **CLOCK** button twice. (During this operation the minutes and the seconds do not advance.)

To change the minute only

Follow steps 1 - 6 but skip step 3.
(During this operation the seconds advance.)

Inserting a Lithium Battery

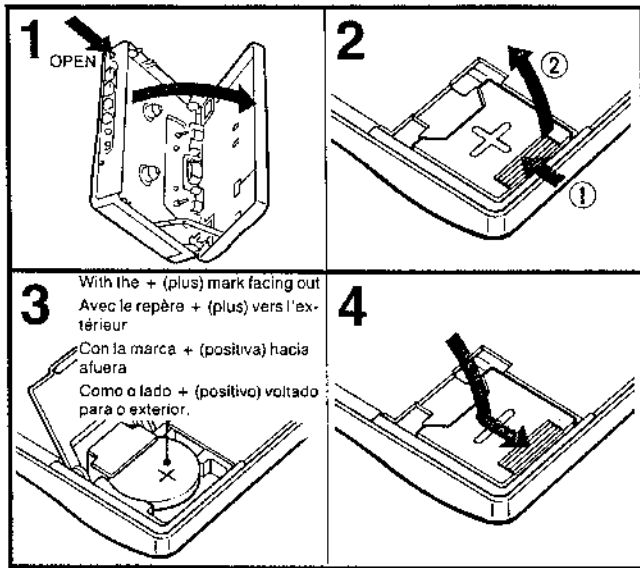

Note

If the lithium battery compartment lid is detached by an accidental drop, etc. attach it as illustrated.

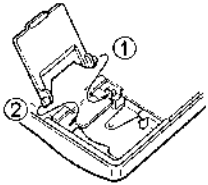

Before operation, be sure to install a lithium battery (supplied). With the lithium battery installed, this unit powers the clock and displays the tape operation indications in the LCD display window during the tape playback.

Lithium battery life

Approximately one year and a half in normal operation. If the lithium battery becomes weak, the letters on the display will become indistinct. In this case, replace the battery with a Sony CR2025 lithium battery. Use of another battery may cause a risk of fire or explosion. After replacing the battery, reset the clock.

Cautions

- Keep the lithium battery out of the reach of children. Should the battery be swallowed, consult a doctor immediately.
- Before use, wipe the battery with a dry cloth to assure a good contact.
- Be sure to observe the correct polarity when installing the battery.
- Do not hold the battery with metallic tweezers, otherwise a short-circuit may occur.
- Do not break up the battery or throw it into a fire because it may explode. Carefully dispose of the used batteries.

Warning

Battery may explode if mistreated. Do not recharge, disassemble or dispose of in fire.

Service Notes

How to check the operation

When audio board has been removed from mechanical deck. Depress the PLAY (▶) button to turn ON the S901 (POWER) and S902 (PLAY).

AUDIO BOARD - Component side -

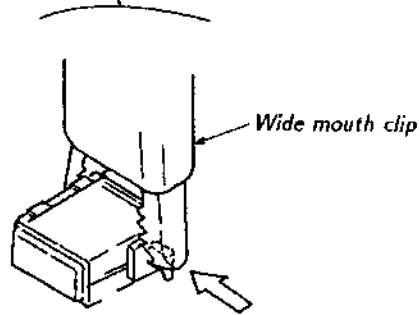
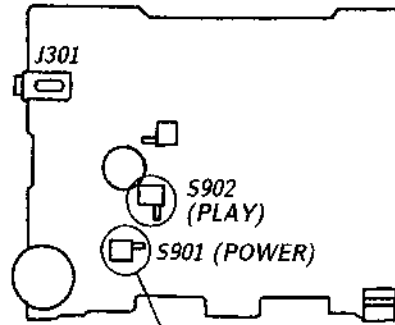

Flexible Circuit Board Repairing

- Keep the temperature of the soldering iron around 270°C during repairing.
- Do not touch the soldering iron on the same conductor of the circuit board (within 3 times).
- Be careful not to apply force on the conductor when soldering or unsoldering.

Notes on Chip Component Replacement

- Never reuse a disconnected chip component.
- Notice that the minus side of a tantalum capacitor may be damaged by heat.

REMOVAL

Note : Follow the disassembly procedure the numerical order given.

Tuner unit (WM-FX50)

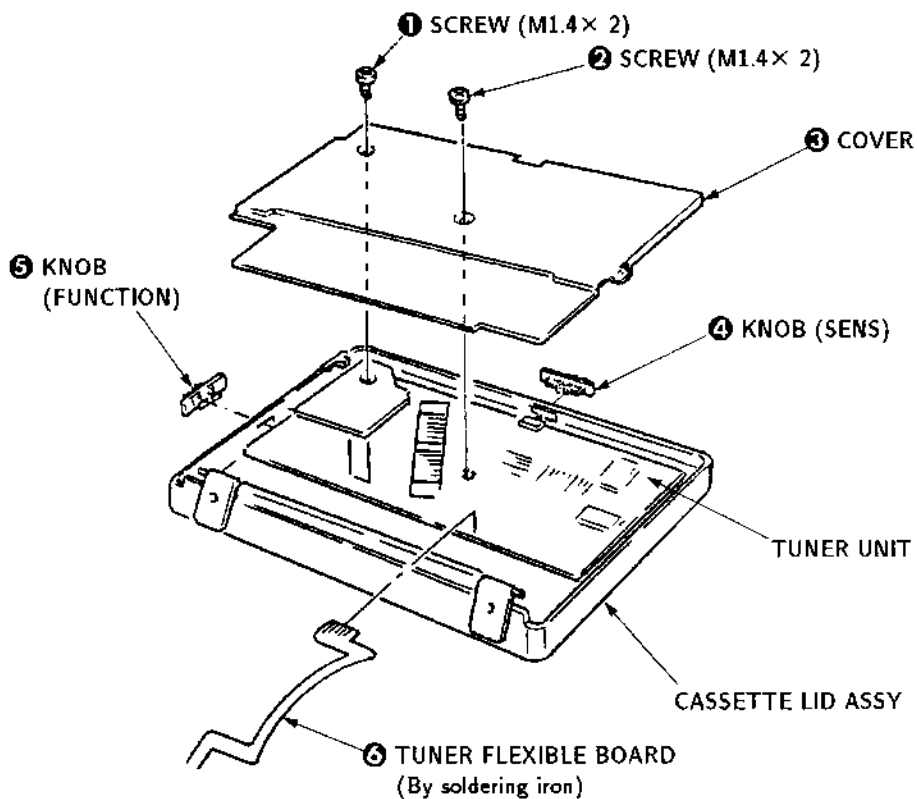

To take off the tuner unit from cassette lid ass'y.

Warm up ⑦ to ⑪ portion by heater and move it slowly by tweezers.

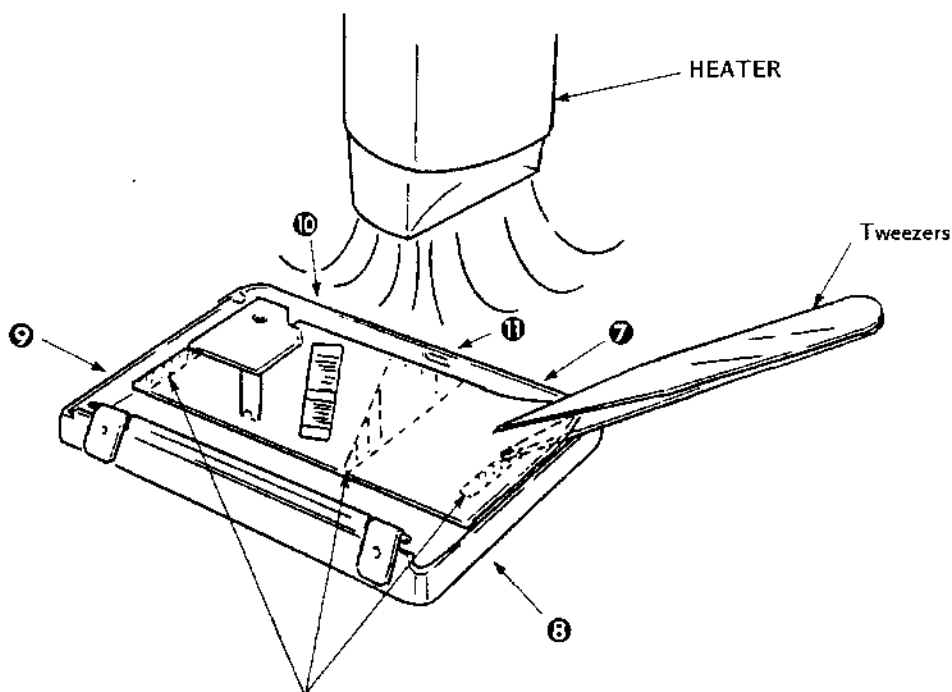

Both sides adhesive sheet

LCD BLOCK INFORMATION

Clock operation

LCD will operate as a clock indication with the following conditions.

1. When the data code 0000 or 0100 feed into input port. (data code show in chart 1)
2. When the dry penlight battery (AM3/LR6) or Ni-Cd battery is not built- in the battery case.

Refer to User's instruction "Setting the clock" page 5.

Tape running indication

LCD will operate as a tape running indication mode when it assembled the data code of chart 1.

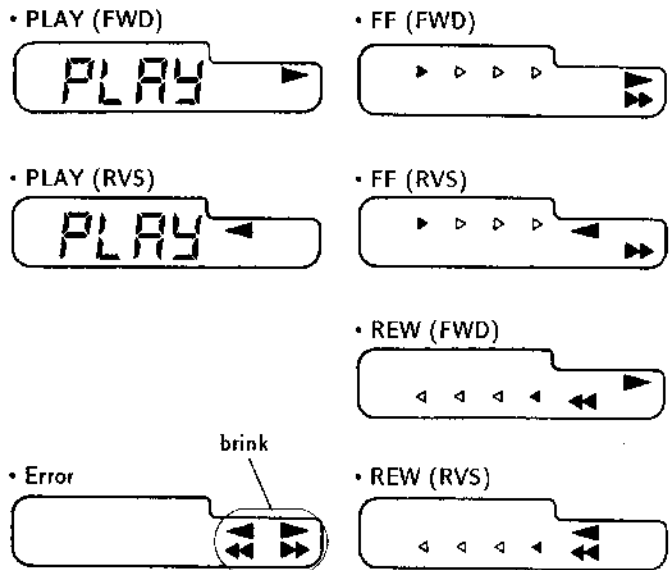

* Error indication mean's to notified to the customer that it is abnormal operation when pushing the MD button in same time.

* The clock will be reset and indicatc AM 12 : 00 after all indicator is light.

Indicator is clock mode when rethium battery take off.

Data code chart and indication mode

Chart 1

No.	PLAY	FWD/RVS	FF	REW	MODE
0	0	0	0	0	Clock
1	0	0	0	1	REW (RVS)
2	0	0	1	0	FF (RVS)
3	0	0	1	1	Error
4	0	1	0	0	Clock
5	0	1	0	1	REW (FWD)
6	0	1	1	0	FF (FWD)
7	0	1	1	1	Error
8	1	0	0	0	PLAY (RVS)
9	1	0	0	1	Error
A	1	0	1	0	Error
B	1	0	1	1	Error
C	1	1	0	0	PLAY (FWD)
D	1	1	0	1	Error
E	1	1	1	0	Error
F	1	1	1	1	Error

BLOCK DIAGRAM

Tuner Section (WM-FX50 ONLY)

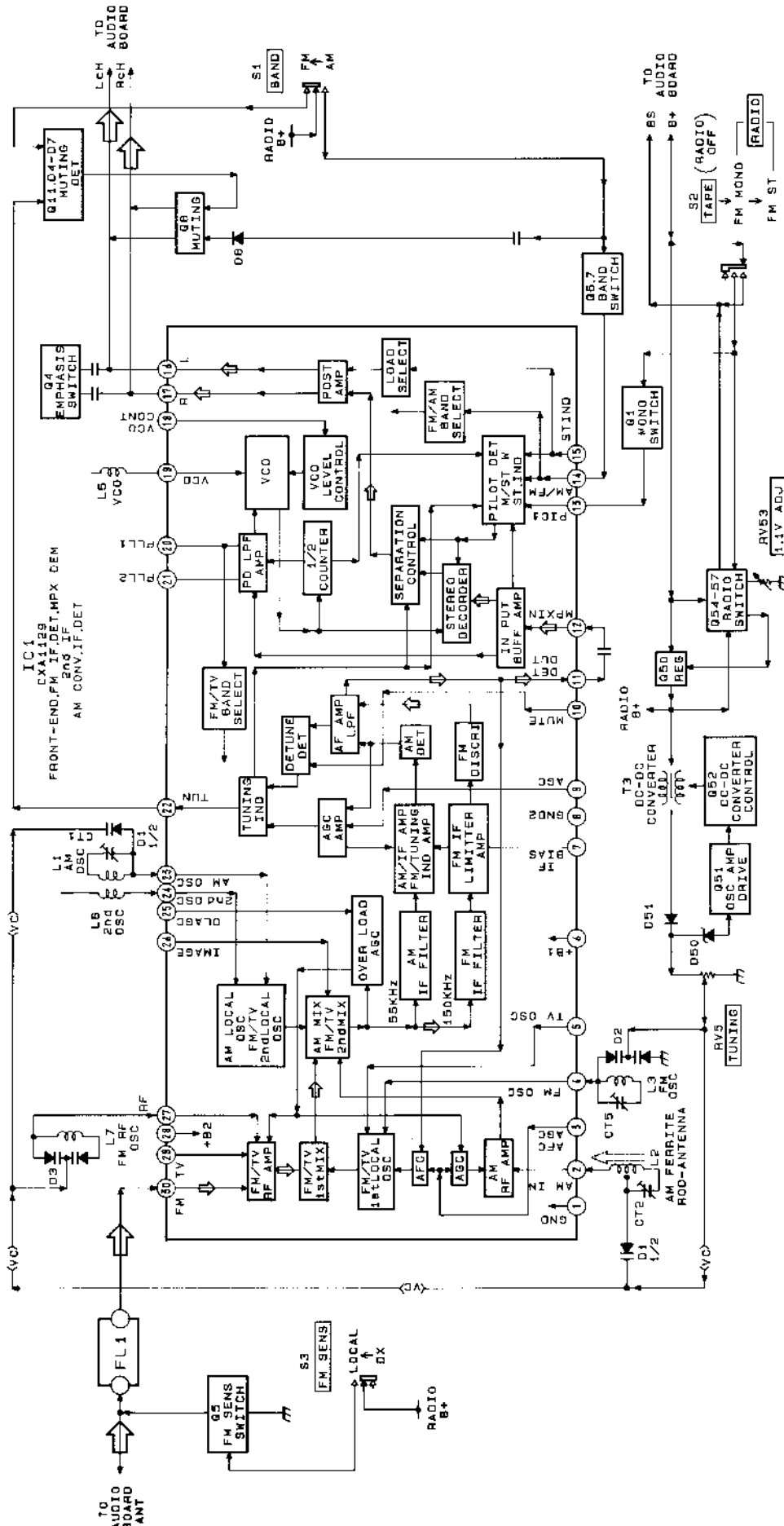

Note:

- Signal path
- ➡ : FM

Audio Section

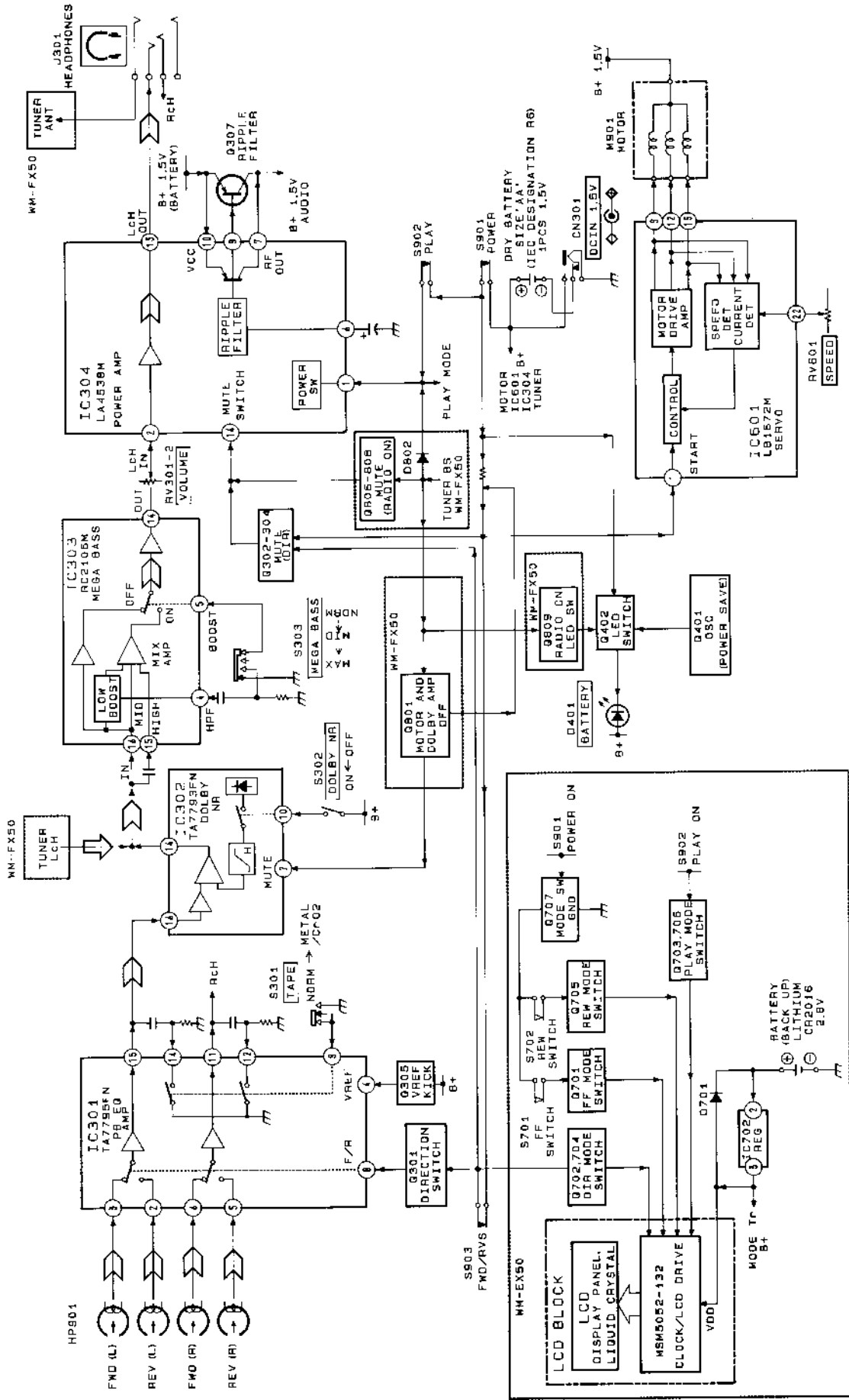

Note :
 • Signal path
 ⇨ : FM
 ⇨ : PB (playback)

SCHEMATICS AND BOARD DIAGRAMS

Tuner Board Schematic Diagram (WM-FX50 ONLY)

Refer to page 14 for Schematic Diagram note.

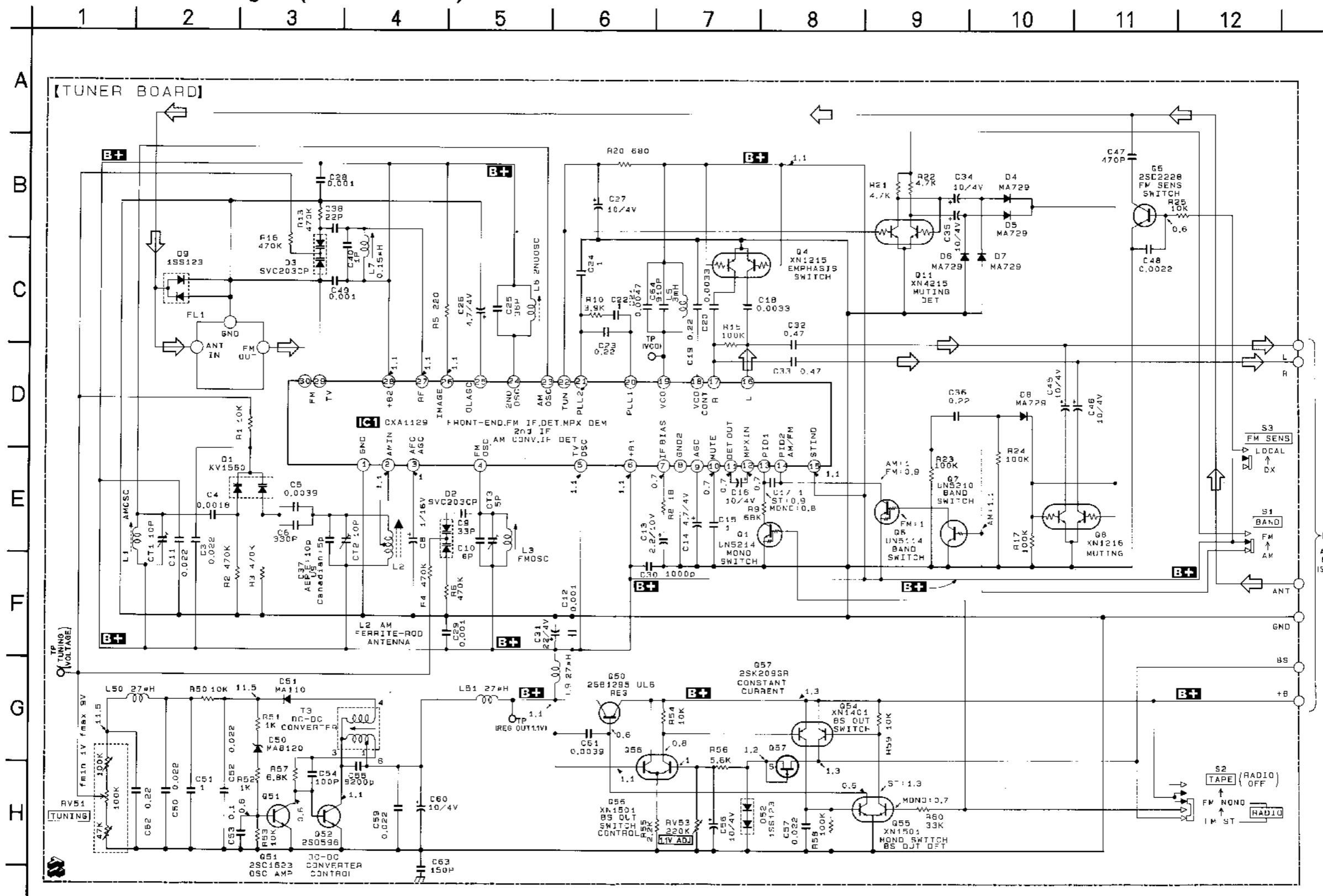

Tuner Board Printed Wiring Boards

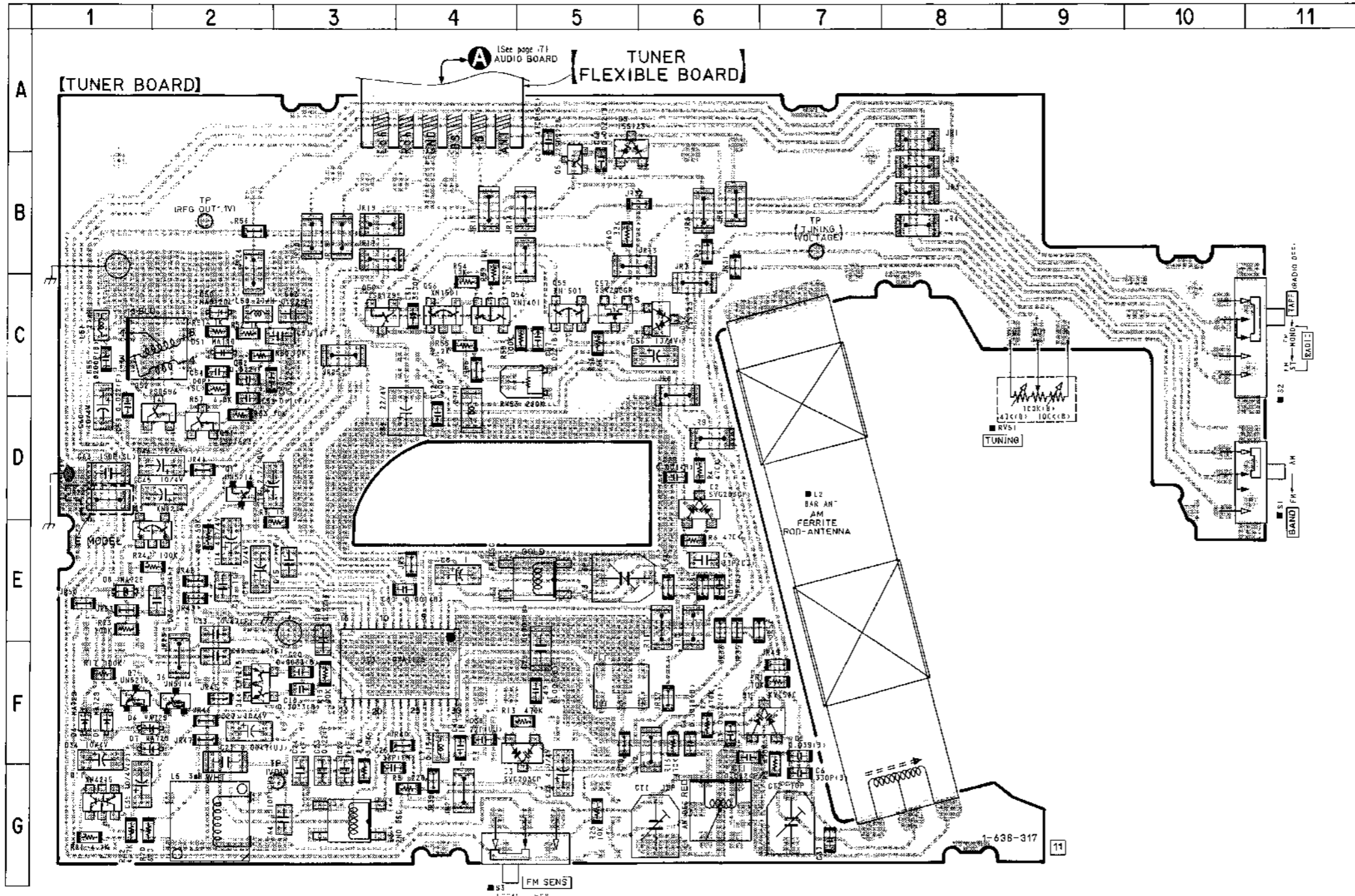

Semiconductor Location

Ref. No.	Location
D1	F-6
D2	D-6
D3	G-4
D4	F-1
D5	F-1
D6	F-1
D7	F-1
D8	E-1
D9	A-5
D50	C-2
D51	C-2
D52	C-6
IC1	F-3
Q1	D-2
Q4	F-2
Q5	B-5
Q6	F-2
Q7	F-1
Q8	D-1
Q11	G-1
Q50	C-3
Q51	D-2
Q52	D-2
Q54	C-4
Q55	C-5
Q56	C-4
Q57	C-5

Semiconductor layouts

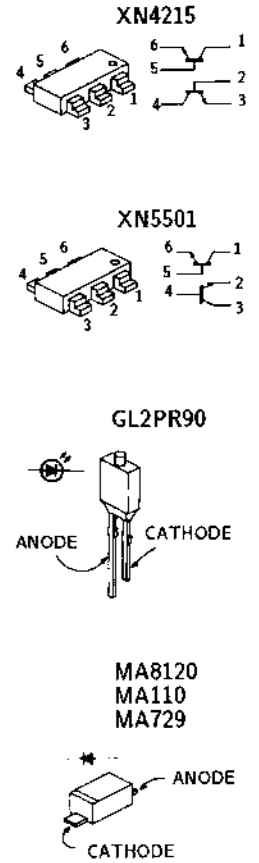

Note on Schematic Diagram :

- All capacitors are in μF unless otherwise noted. pF : $\mu \mu F$. 50WV or less are not indicated except for electrolytics and tantalums.
- All resistors are in Ω and $\frac{1}{2}W$ or less unless otherwise specified.
- **B+** : B+ Line
- : adjustment for repair.
- Power voltage is dc 1.3V and fed with regulated dc power supply from external power voltage jack.
- Voltage and waveforms are dc with respect to ground under no-signal (detuned) conditions.
 - no mark : FM
- Voltages are taken with a VOM (input impedance 10M Ω). Voltage variations may be noted due to normal production tolerances.
- Signal path.
 - : FM

Note on Printed Wiring Boards :

- : parts mounted on the conductor side.
- : Pattern on the side which is seen.

Audio Board Schematic Diagram

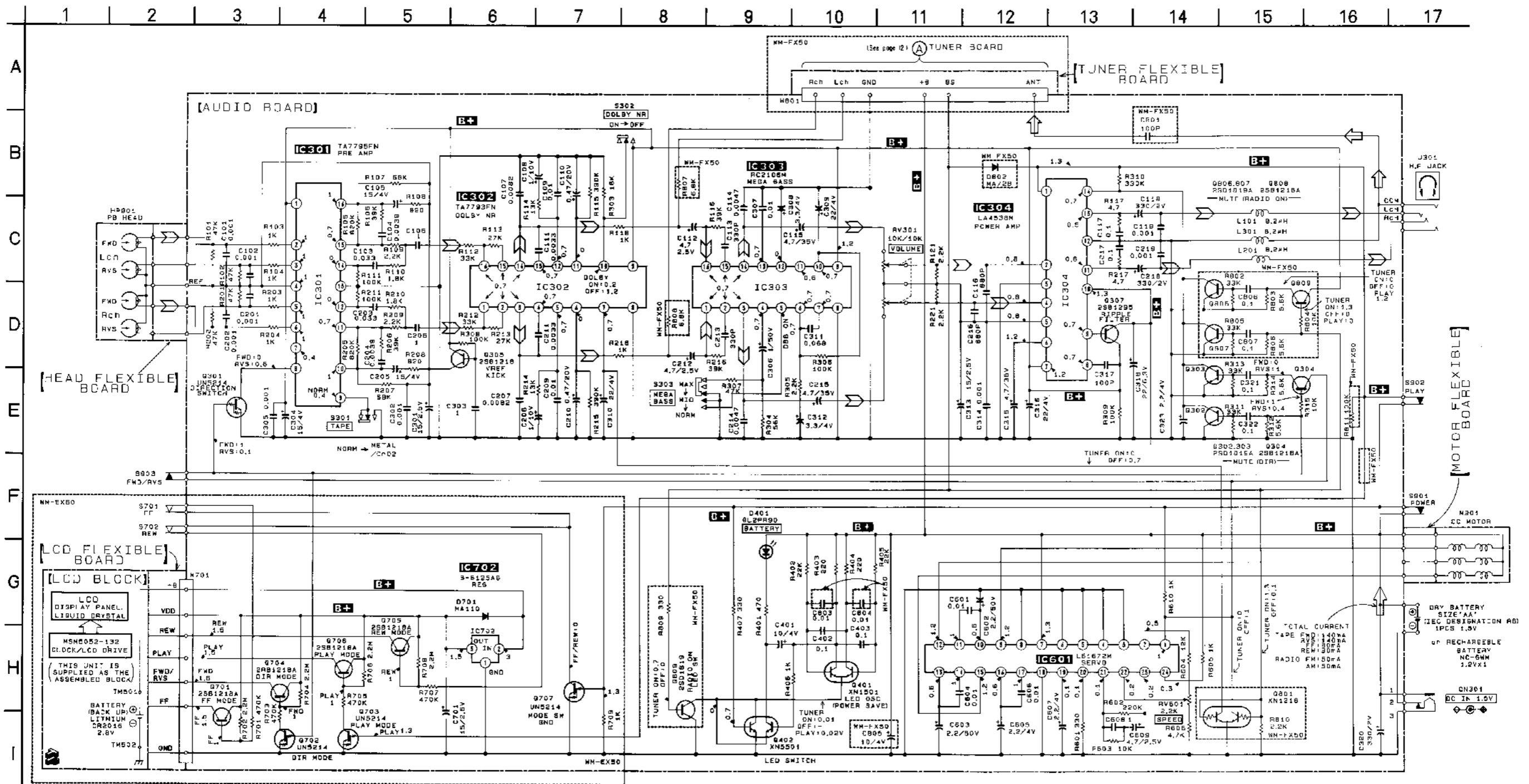

- Note:
- All capacitors are in μF unless otherwise noted. pF: $\mu \mu F$. 50WV or less are not indicated except for electrolytics and tantalums.
 - All resistors are in Ω and $\frac{1}{4}W$ or less unless otherwise specified.
 - B+**: B- Line
 - : adjustment for repair.
 - Total current is measured with no cassette installed.
 - Power voltage is dc 1.3V and fed with regulated dc power supply from external power voltage jack.
 - Voltage and waveforms are dc with respect to ground under no-signal (in playback mode) conditions.
no mark: FWD
 - Voltages are taken with a VOM (input impedance 10M Ω). Voltage variations may be noted due to normal production tolerances.
 - Signal path.
→: FM ⇄: PB

Audio Board Printed Wiring Boards

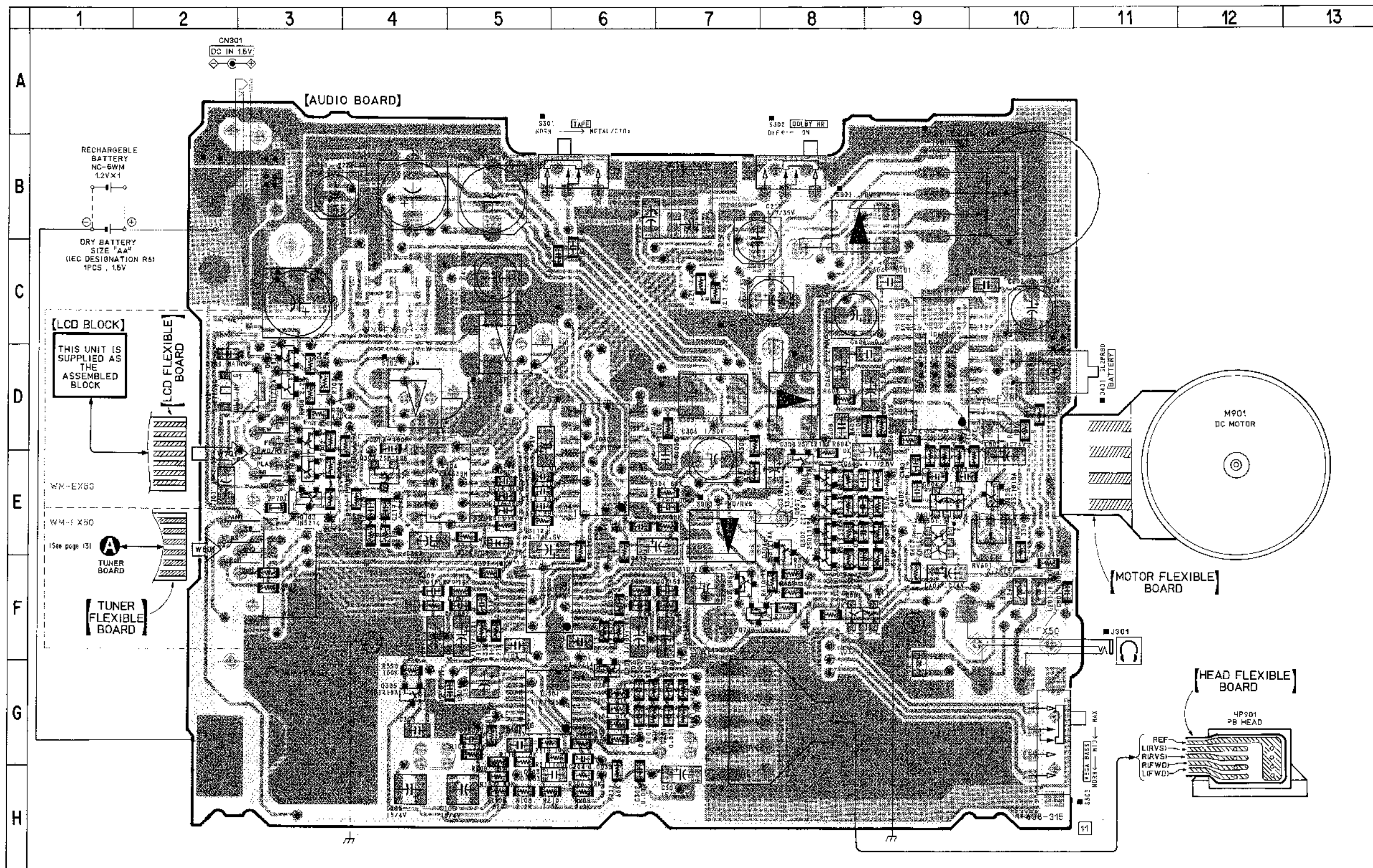

Semiconductor Locations

Ref. No.	Location
D401	D-10
D701	D-2
D802	E-5
IC301	G-5
IC302	F-5
IC303	D-6
IC304	E-5
IC601	C-9
IC702	D-2
Q301	G-6
Q302	E-8
Q303	F-8
Q304	E-8
Q305	G-4
Q307	E-4
Q401	E-9
Q402	E-9
Q701	D-3
Q702	F-7
Q703	E-3
Q704	D-3
Q705	D-3
Q706	E-3
Q707	F-7
Q801	F-8
Q806	E-8
Q807	E-8
Q808	E-8
Q809	E-10

Note:

- ■ : parts mounted on the conductor side.
- ⊙ : Through hole.
- ▨ : Pattern on the side which is seen.
- ▩ : Pattern of the rear side.

IC layouts

IC301 TA7795F

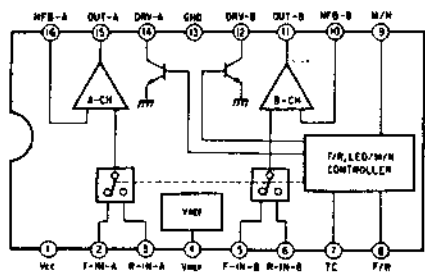

IC304 LA4538M

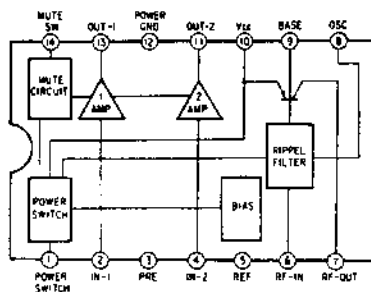

IC302 TA7793F

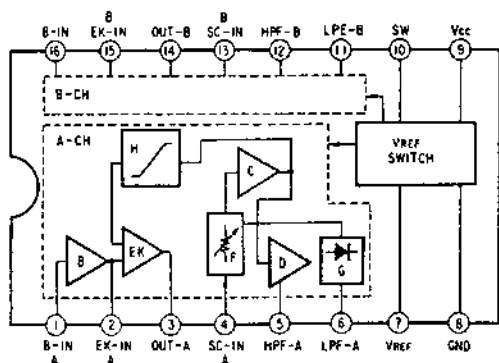

IC601 LB1672M

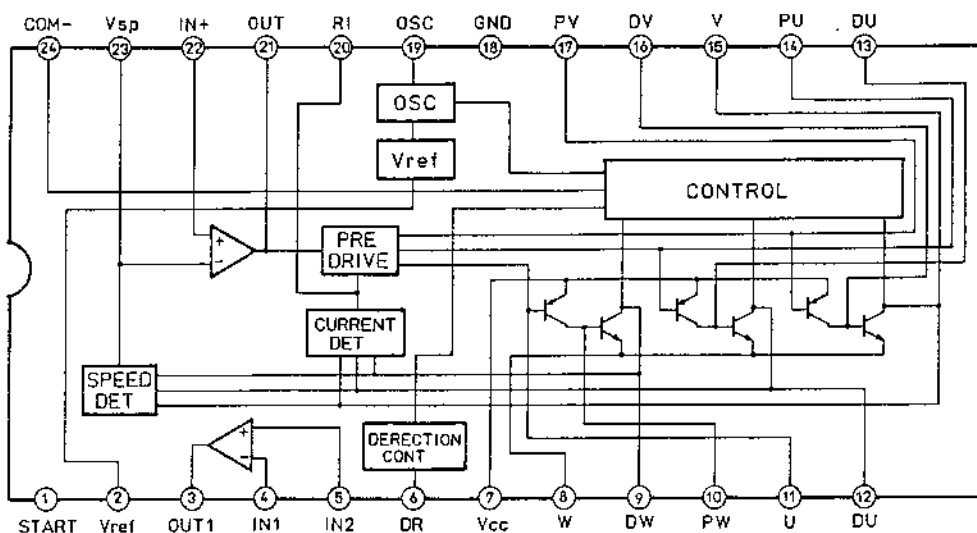

SPARE PARTS LIST

Exploded Views and Mechanical Parts

NOTE:

—XX, —X mean standardized parts, so they may have some differences from the original one.

The construction parts of an assembled part are indicated with a collation number in the remark column.

Color indication of Appearance Parts

Example:

KNOB, BALANCE (WHITE)...(RED)

Parts color Cabinet's color

Items marked "*" are not stocked since they are seldom required for routine service. Some delay should be anticipated when ordering these items. The mechanical parts with no reference number in the exploded views are not supplied.

● Hardware (#mark) list is given in the last of this parts list.

CABINET

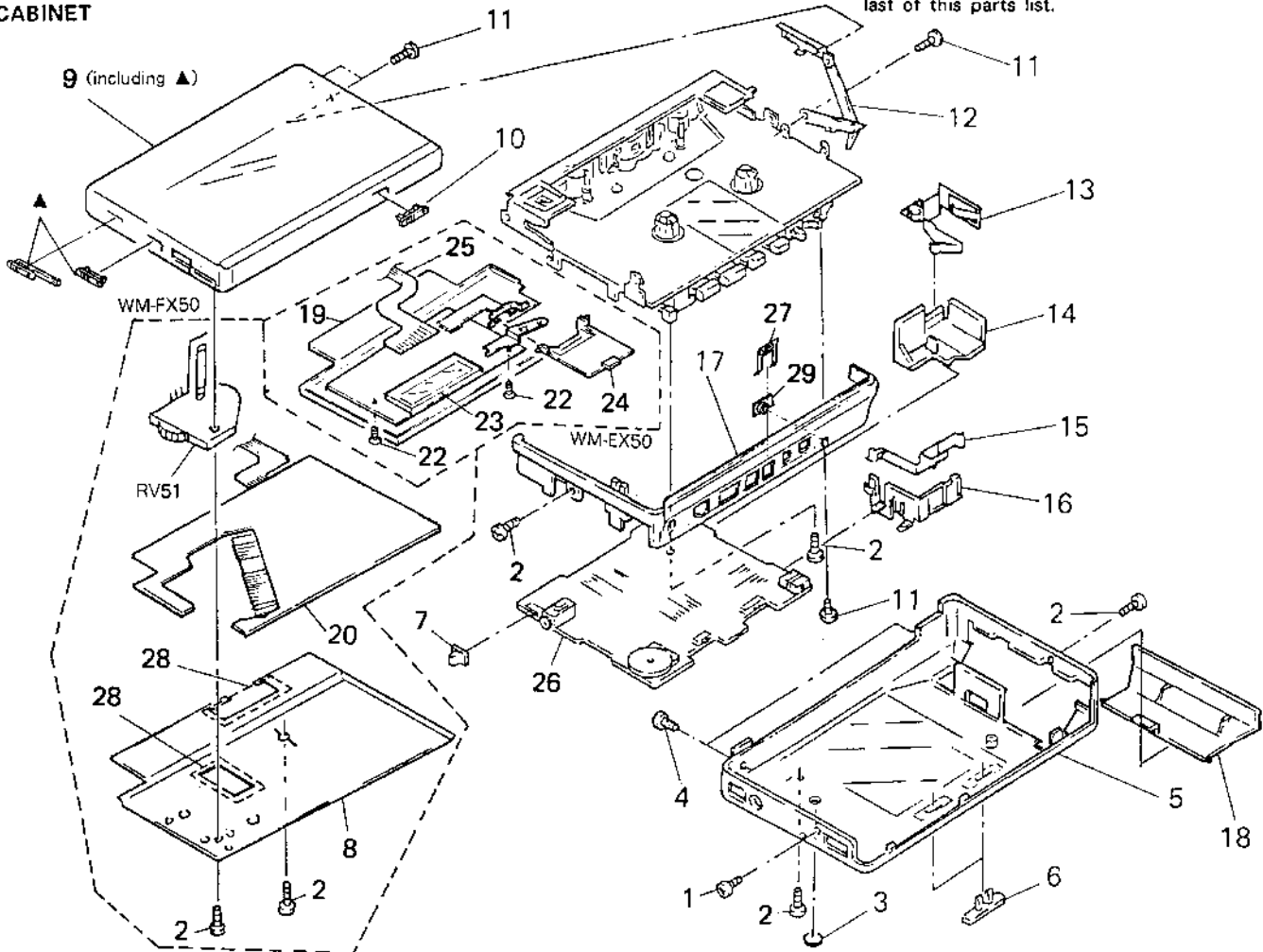

Ref. No.	Part No.	Description	Remark
1	3-704-197-61	SCREW (M1.4X4.0), LOCKING	
2	3-704-197-11	SCREW (M1.4X2.0), LOCKING	
3	3-342-380-01	SHEET, SPEED HOLE (BLACK)	
3	3-368-118-01	SHEET, SPEED HOLE (GRAY)	
4	3-704-197-31	SCREW (M1.4X3.0), LOCKING	
5	X-3362-867-1	CABINET (REAR) ASSY (BLACK) (FX50:AEP, E)	
5	X-3362-872-1	CABINET (REAR) ASSY (BLACK) (EX50:AEP, E)	
5	X-3362-875-1	CABINET (REAR) ASSY (GRAY) (EX50)	
5	X-3362-870-1	CABINET (REAR) ASSY (GRAY)	
5		(FX50:US, Canadian, E)	
6	3-352-045-01	KNOB (TAPE)	
7	3-348-186-01	KNOB (DBB)	
8	3-367-795-01	COVER (FX50)	
9	X-3362-868-1	LID ASSY, CASSETTE (BLACK) (FX50:AEP, E)	
9	X-3362-873-1	LID ASSY, CASSETTE (BLACK) (EX50:AEP, E)	
9	X-3362-874-1	LID ASSY, CASSETTE (GRAY) (EX50)	
9	X-3362-871-1	LID ASSY, CASSETTE (GRAY) (FX50:E)	
9	X-3363-078-1	LID ASSY, CASSETTE (GRAY)	
		(FX50:US, Canadian)	
10	3-367-791-01	KNOB (LOCAL/DX)	
11	3-704-197-01	SCREW (M1.4X1.6), LOCKING	

Ref. No.	Part No.	Description	Remark
12	X-3352-013-1	ARM ASSY, CLICK	
13	3-357-914-01	TERMINAL BOARD, MINUS	
14	3-352-050-01	HOLDER (B), TERMINAL	
15	3-352-047-01	TERMINAL BOARD, PLUS	
16	3-352-049-01	HOLDER (A), TERMINAL	
17	3-367-812-01	ORNAMENTAL REEL	
18	3-367-803-01	LID, BATTERY CASE (GRAY)	
18	3-367-803-11	LID, BATTERY CASE (BLACK)	
19	3-367-801-01	PLATE, BLIND (EX50)	
20	A-3016-050-A	TUNER BOARD, COMPLETE (FX50:AEP, E)	
20	A-3016-055-A	TUNER BOARD, COMPLETE (FX50:US, Canadian)	
21	1-638-316-11	FLEXIBLE BOARD, TUNER (FX50)	
22	3-318-382-61	SCREW (1.7X2.5), TAPPING (EX50)	
23	1-809-282-11	DISPLAY PANEL BLOCK, LIQUID CRYSTAL (EX50)	
24	3-367-802-01	LID (LITHIUM), BATTERY CASE (EX50)	
25	1-638-314-11	PC BOARD, LCD FLEXIBLE (EX50)	
26	A-3016-049-A	AUDIO BOARD, COMPLETE (FX50)	
26	A-3016-051-A	AUDIO BOARD, COMPLETE (EX50)	
27	3-367-804-01	SPRING, CASSETTE RETAINER	
28	3-347-289-01	SHEET (COVER) (FX50)	
29	* 3-368-117-01	SPACER	

TAPE TRANSPORT (1)

(WM-EX50 : MT-WMEX50-01)
 (WM-FX50 : MT-WMFX50-01)

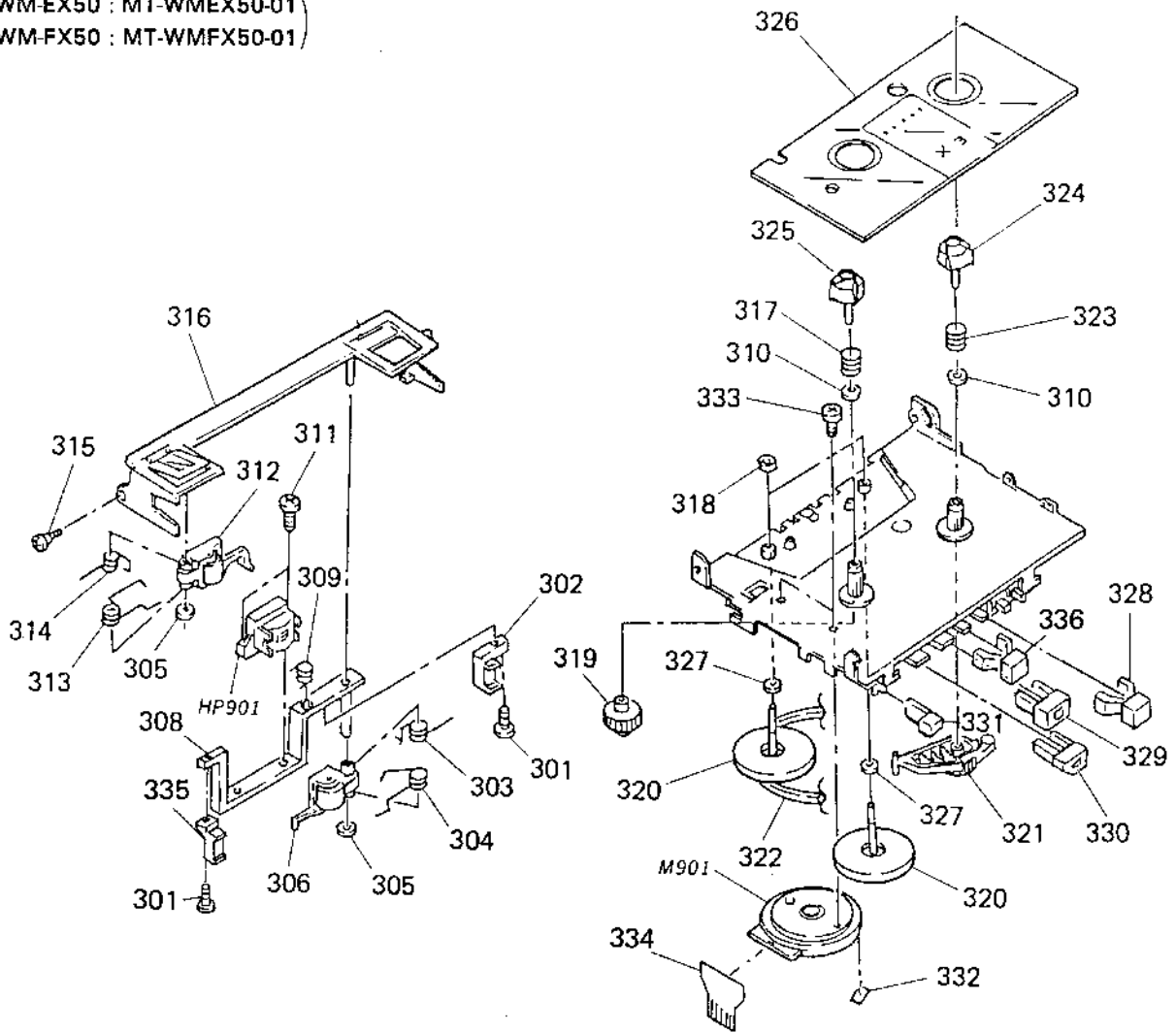

Ref. No.	Part No.	Description	Remark
301	3-348-998-31	SCREW (M1.4X2.5), TAPPING, PAN	
302	3-344-693-01	GUIDE (LEFT)	
303	3-341-468-01	SPRING (R)	
304	3-354-420-01	SPRING (PINCH RK), TORSION	
305	3-341-473-01	WASHER (MP)	
306	X-3331-035-1	PINCH LEVER (R) ASSY	
308	3-345-725-01	LEVER (AZ), HEAD	
309	3-347-205-01	SPRING (HD LEVER), TORSION	
310	3-355-356-01	WASHER	
311	3-348-998-71	SCREW (M1.4X4.5), TAPPING, PAN	
312	X-3331-036-1	PINCH LEVER (N) ASSY	
313	3-354-421-01	SPRING (PINCH NK), TORSION	
314	3-341-469-01	SPRING (N)	
315	3-352-005-01	SCREW (M1.4X1.6), PRECISION STEP	
316	X-3352-009-1	HOLDER (X) ASSY (EX50)	
316	X-3362-810-1	HOLDER (S.T) ASSY (FX50)	
317	3-348-989-01	SPRING, COMPRESSION	
318	3-352-098-01	WASHER, STOPPER	
319	3-348-151-01	GEAR (TAKE-UP REEL)	
320	X-3352-007-1	WHEEL (X) ASSY, CAPSTAN	

Ref. No.	Part No.	Description	Remark
321	X-3348-110-1	LEVER ASSY, PICK UP	
322	3-349-814-01	BELT	
323	3-354-494-01	SPRING (S REEL), COMPRESSION	
324	3-348-149-01	REEL, SUPPLY	
325	3-348-150-01	REEL, TAKE-UP	
326	3-352-010-01	COVER (X), MD	
326	3-354-467-01	COVER, MD	
327	3-354-407-01	WASHER	
328	3-367-362-01	BUTTON (REW)	
329	3-367-363-01	BUTTON (STOP)	
330	3-367-361-01	BUTTON (FWD)	
331	3-367-359-01	BUTTON (OPEN)	
333	3-354-448-01	SCREW (TOOTH)	
334	1-638-313-11	PC BOARD, MOTOR FLEXIBLE	
335	3-344-694-01	GUIDE (RIGHT)	
336	3-367-360-01	BUTTON (FF)	
HP901	1-543-812-11	HEAD, MAGNETIC (PLAYBACK)	
M901	1-541-660-11	MOTOR	

TAPE TRANSPORT (2)

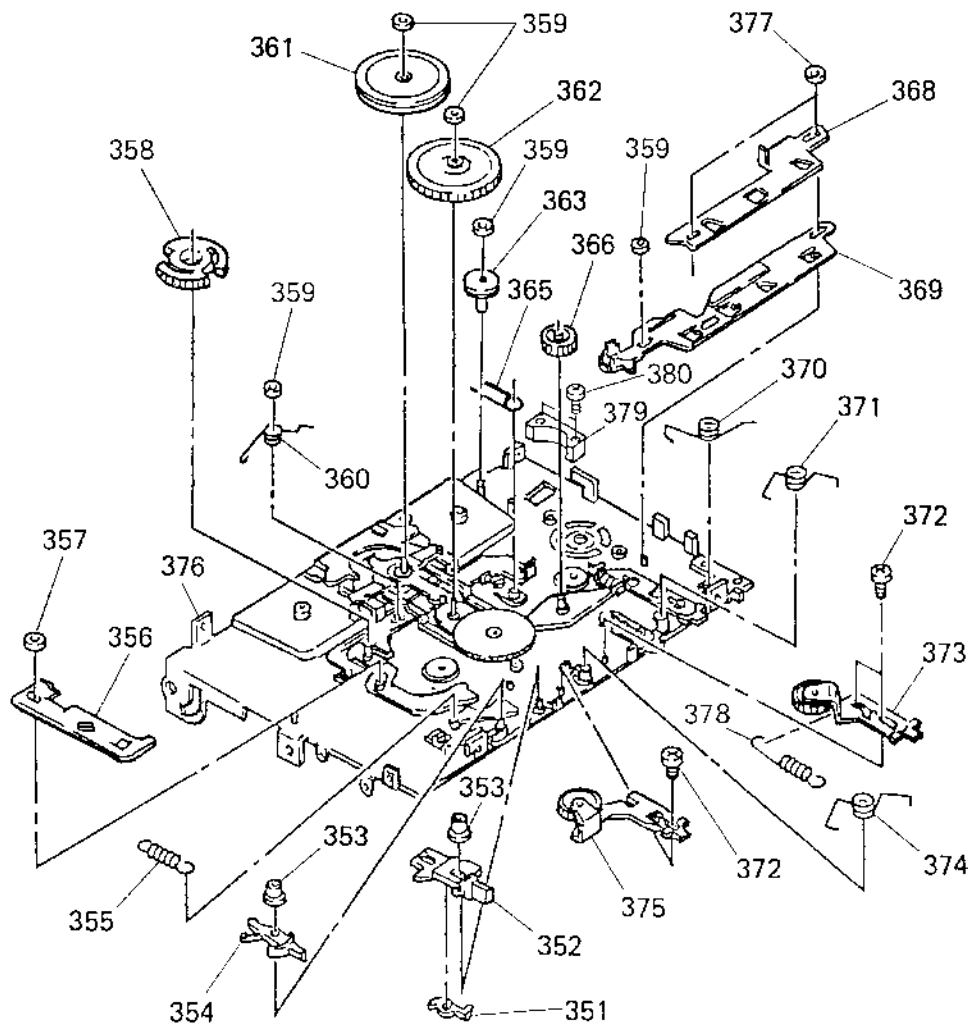

Ref. No.	Part No.	Description	Remark
351	3-348-101-01	RATCHET	
352	3-348-156-01	LEVER, DIR (MADE IN JAPAN)	
352	3-364-971-01	LEVER, DIR (MADE IN CHINESE)	
353	3-348-102-01	BUSHING	
354	3-348-105-01	LEVER, MODE SELECTION	
355	3-348-153-01	SPRING, TENSION	
356	3-352-002-02	LEVER (X), TRIGGER	
357	3-348-953-11	WASHER	
358	3-352-032-01	GEAR (X), CAM	
359	3-348-936-01	WASHER	
360	3-348-172-03	SPRING (S. OFF), TORSION	
361	3-352-007-01	PULLEY (MIDWAY, X)	
362	X-3352-027-3	CLUTCH (X) ASSY	
363	3-354-470-01	PULLEY (REVERSE X, T)	
365	3-348-159-01	SPRING (NR), TORSION	
366	3-352-021-01	GEAR (N, X)	

Ref. No.	Part No.	Description	Remark
368	3-352-028-01	LEVER (X), SW	
369	X-3348-102-1	LEVER ASSY, LOCK (MADE IN JAPAN)	
369	X-3362-240-1	LEVER ASSY, LOCK (MADE IN CHINESE)	
370	3-348-162-01	SPRING (LOCK), TORSION	
371	3-348-103-01	SPRING (PLAY), TORSION	
372	3-348-160-01	SCREW (M1. 4X1. 3), PRECISION PAN	
373	X-3352-812-1	LEVER (X) ASSY, FF	
374	3-348-168-01	SPRING (FR), TORSION (MADE IN JAPAN)	
374	3-395-577-01	SPRING (FR), TORSION (MADE IN CHINESE)	
375	X-3362-811-1	LEVER (X) ASSY, REW	
376	X-3363-113-1	CHASSIS (X) COMP ASSY	
377	3-357-927-01	WASHER	
378	3-352-026-01	SPRING, TENSION	
379	3-357-918-01	GUIDE (BELT)	
380	3-704-252-41	SCREW (M1. 4X6)	

Electrical Parts



NOTE:

Due to standardization, replacements in the parts list may be different from the parts specified in the diagrams or the components used on the set.

- -XX, -X mean standardized parts, so they may have some difference from the original one.
- RESISTORS
All resistors are in ohms
METAL: Metal-film resistor
METAL OXIDE: Metal Oxide-film resistor
F: nonflammable

Items marked "*" are not stocked since they are seldom required for routine service. Some delay should be anticipated when ordering these items.

- SEMICONDUCTORS
In each case, μ : for example:
uA.....: μ A....., uPA.....: μ PA.....
uPB.....: μ PB....., uPC.....: μ PC.....
uPD.....: μ PD.....
- CAPACITORS
uF: μ F
- COILS
uH: μ H

Ref. No.	Part No.	Description	Remark	Ref. No.	Part No.	Description	Remark
	A-3016-049-A	AUDIO BOARD, COMPLETE (FX50)		C206	1-164-346-11	CERAMIC CHIP 1uF	16V
	A-3016-051-A	AUDIO BOARD, COMPLETE (EX50)		C207	1-164-174-11	CERAMIC CHIP 0.0082uF	10% 25V
	*****			C208	1-135-208-11	TANTAL. CHIP 1uF	10% 10V
	3-352-047-01	TERMINAL BOARD, PLUS		C209	1-162-970-11	CERAMIC CHIP 0.01uF	10% 25V
	3-352-049-01	HOLDER (A), TERMINAL		C210	1-135-192-21	TANTAL. CHIP 0.47uF	10% 20V
	3-352-050-01	HOLDER (B), TERMINAL		C211	1-162-967-11	CERAMIC CHIP 0.0033uF	10% 50V
	3-357-914-01	TERMINAL BOARD, MINUS		C212	1-135-218-11	TANTAL. CHIP 4.7uF	20% 2.5V
	< CAPACITOR >			C213	1-162-961-11	CERAMIC CHIP 330PF	10% 50V
C101	1-152-964-11	CERAMIC CHIP 0.001uF	10% 50V	C214	1-162-968-11	CERAMIC CHIP 0.0047uF	10% 50V
C102	1-152-964-11	CERAMIC CHIP 0.001uF	10% 50V	C215	1-126-603-11	ELECT CHIP 4.7uF	20% 35V
C103	1-153-989-11	CERAMIC CHIP 0.033uF	10% 25V	C216	1-162-963-11	CERAMIC CHIP 680PF	10% 50V
C104	1-154-173-11	CERAMIC CHIP 0.0039uF	10% 50V	C217	1-164-156-11	CERAMIC CHIP 0.1uF	25V
C105	1-135-158-21	TANTALUM CHIP 15uF	20% 4V	C218	1-126-608-11	ELECT 330uF	20% 2V
C106	1-154-346-11	CERAMIC CHIP 1uF	16V	C219	1-162-964-11	CERAMIC CHIP 0.001uF	10% 50V
C107	1-154-174-11	CERAMIC CHIP 0.0082uF	10% 25V	C301	1-135-219-11	TANTAL. CHIP 15uF	20% 2.5V
C108	1-135-208-11	TANTAL. CHIP 1uF	10% 10V	C302	1-162-964-11	CERAMIC CHIP 0.001uF	10% 50V
C109	1-152-970-11	CERAMIC CHIP 0.01uF	10% 25V	C303	1-164-346-11	CERAMIC CHIP 1uF	16V
C110	1-135-192-21	TANTAL. CHIP 0.47uF	10% 20V	C304	1-135-158-21	TANTALUM CHIP 15uF	20% 4V
C111	1-162-967-11	CERAMIC CHIP 0.0033uF	10% 50V	C305	1-162-964-11	CERAMIC CHIP 0.001uF	10% 50V
C112	1-135-218-11	TANTAL. CHIP 4.7uF	20% 2.5V	C306	1-126-193-11	ELECT 1uF	20% 50V
C113	1-162-961-11	CERAMIC CHIP 330PF	10% 50V	C307	1-162-970-11	CERAMIC CHIP 0.01uF	10% 25V
C114	1-162-968-11	CERAMIC CHIP 0.0047uF	10% 50V	C308	1-135-221-11	TANTAL. CHIP 3.3uF	20% 4V
C115	1-126-603-11	ELECT CHIP 4.7uF	20% 35V	C309	1-126-590-11	ELECT CHIP 22uF	20% 4V
C116	1-152-963-11	CERAMIC CHIP 680PF	10% 50V	C310	1-135-202-21	TANTAL. CHIP 22uF	20% 4V
C117	1-154-156-11	CERAMIC CHIP 0.1uF	25V	C311	1-163-833-00	CERAMIC CHIP 0.068uF	25V
C118	1-126-608-11	ELECT 330uF	20% 2V	C312	1-135-221-11	TANTAL. CHIP 3.3uF	20% 4V
C119	1-162-964-11	CERAMIC CHIP 0.001uF	10% 50V	C313	1-135-219-11	TANTAL. CHIP 15uF	20% 2.5V
C201	1-162-964-11	CERAMIC CHIP 0.001uF	10% 50V	C314	1-162-964-11	CERAMIC CHIP 0.001uF	10% 50V
C202	1-152-964-11	CERAMIC CHIP 0.001uF	10% 50V	C315	1-126-603-11	ELECT CHIP 4.7uF	20% 35V
C203	1-153-989-11	CERAMIC CHIP 0.033uF	10% 25V	C316	1-126-590-11	ELECT CHIP 22uF	20% 4V
C204	1-164-173-11	CERAMIC CHIP 0.0039uF	10% 50V	C317	1-162-953-11	CERAMIC CHIP 100PF	5% 50V
C205	1-135-158-21	TANTALUM CHIP 15uF	20% 4V	C318	1-126-605-11	ELECT 22uF	20% 6.3V
				C320	1-126-608-11	ELECT 330uF	20% 2V
				C321	1-164-156-11	CERAMIC CHIP 0.1uF	25V

AUDIO

Ref. No.	Part No.	Description	Remark
C322	1-164-156-11	CERAMIC CHIP	0.1uF 25V
C323	1-135-187-21	TANTAL. CHIP	2.2uF 20% 4V
C401	1-135-201-11	TANTALUM CHIP	10uF 20% 4V
C402	1-164-156-11	CERAMIC CHIP	0.1uF 25V
C403	1-164-156-11	CERAMIC CHIP	0.1uF 25V
C601	1-164-232-11	CERAMIC CHIP	0.01uF 50V
C602	1-126-601-11	ELECT	2.2uF 20% 50V
C603	1-126-601-11	ELECT	2.2uF 20% 50V
C604	1-164-232-11	CERAMIC CHIP	0.01uF 50V
C605	1-135-187-21	TANTAL. CHIP	2.2uF 20% 4V
C606	1-164-232-11	CERAMIC CHIP	0.01uF 50V
C607	1-135-187-21	TANTAL. CHIP	2.2uF 20% 4V
C608	1-164-346-11	CERAMIC CHIP	1uF 16V
C609	1-135-218-11	TANTAL. CHIP	4.7uF 20% 2.5V
C701	1-135-219-11	TANTAL. CHIP	15uF 20% 2.5V (EX50)
C801	1-162-953-11	CERAMIC CHIP	100PF 5% 50V (FX50)
C803	1-162-970-11	CERAMIC CHIP	0.01uF 10% 25V (FX50)
C804	1-162-970-11	CERAMIC CHIP	0.01uF 10% 25V (FX50)
C805	1-135-201-11	TANTALUM CHIP	10uF 20% 4V (FX50)
C806	1-164-156-11	CERAMIC CHIP	0.1uF 25V (FX50)
C807	1-164-156-11	CERAMIC CHIP	0.1uF 25V (FX50)
< CONNECTOR >			
CN301	1-580-919-11	JACK, DC (POLARITY UNIFIED TYPE)	(DC IN 1.5V)
< DIODE >			
D401	8-719-976-16	DIODE	GL2PR90 (BATTERY)
D701	8-719-404-46	DIODE	MA110 (EX50)
D802	8-719-421-27	DIODE	MA728 (FX50)
< IC >			
IC301	8-759-230-91	IC	TA7795FN
IC302	8-759-230-88	IC	TA7793FN
IC303	8-759-512-77	IC	RC2106M
IC304	8-759-805-02	IC	LA4538M
IC601	8-759-821-20	IC	LB1672M
IC702	8-759-515-82	IC	S-8125AG-RK-S (EX50)
< JACK >			
J301	1-568-467-11	JACK (PHONES)	
< RESISTOR >			
JR701	1-216-864-11	METAL GLAZE	0 5% 1/16W (EX50)

Ref. No.	Part No.	Description	Remark
< COIL >			
L101	1-412-005-11	INDUCTOR CHIP	8.2uH
L201	1-412-005-11	INDUCTOR CHIP	8.2uH
L301	1-412-005-11	INDUCTOR CHIP	8.2uH
< TRANSISTOR >			
Q301	8-729-421-26	TRANSISTOR	UN5216QRS
Q302	8-729-402-32	TRANSISTOR	2SD1819A-R
Q303	8-729-402-32	TRANSISTOR	2SD1819A-R
Q304	8-729-402-55	TRANSISTOR	2SB1218A-R
Q305	8-729-402-55	TRANSISTOR	2SB1218A-R
Q307	8-729-807-87	TRANSISTOR	2SB1295-UL6
Q401	8-729-421-23	TRANSISTOR	XN1216
Q402	8-729-402-75	TRANSISTOR	XN5501
Q701	8-729-402-55	TRANSISTOR	2SB1218A-R (EX50)
Q702	8-729-421-26	TRANSISTOR	UN5216QRS (EX50)
Q703	8-729-421-26	TRANSISTOR	UN5215QRS (EX50)
Q704	8-729-402-55	TRANSISTOR	2SB1218A-R (EX50)
Q705	8-729-402-55	TRANSISTOR	2SB1218A-R (EX50)
Q706	8-729-402-55	TRANSISTOR	2SB1218A-R (EX50)
Q707	8-729-421-26	TRANSISTOR	UN5216QRS (EX50)
Q801	8-729-421-23	TRANSISTOR	XN1216 (FX50)
Q806	8-729-402-32	TRANSISTOR	2SD1819A-R (FX50)
Q807	8-729-402-32	TRANSISTOR	2SD1819A-R (FX50)
Q808	8-729-402-55	TRANSISTOR	2SB1218A-R (FX50)
Q809	8-729-402-32	TRANSISTOR	2SD1819A-R (FX50)
< RESISTOR >			
R101	1-216-841-11	METAL CHIP	47K 5% 1/16W
R102	1-216-841-11	METAL CHIP	47K 5% 1/16W
R103	1-216-821-11	METAL CHIP	1K 5% 1/16W
R104	1-216-821-11	METAL CHIP	1K 5% 1/16W
R105	1-216-856-11	METAL CHIP	820K 5% 1/16W
R106	1-216-840-11	METAL CHIP	39K 5% 1/16W
R107	1-216-843-11	METAL CHIP	68K 5% 1/16W
R108	1-216-820-11	METAL CHIP	820 5% 1/16W
R109	1-216-825-11	METAL CHIP	2.2K 5% 1/16W
R110	1-216-824-11	METAL CHIP	1.8K 5% 1/16W
R111	1-216-845-11	METAL CHIP	100K 5% 1/16W
R112	1-216-839-11	METAL CHIP	33K 5% 1/16W
R113	1-216-838-11	METAL CHIP	27K 5% 1/16W
R114	1-216-994-11	METAL GLAZE	13K 5% 1/16W
R115	1-216-852-11	METAL CHIP	390K 5% 1/16W
R116	1-216-840-11	METAL CHIP	39K 5% 1/16W
R117	1-216-793-11	METAL GLAZE	4.7 5% 1/16W
R118	1-216-821-11	METAL CHIP	1K 5% 1/16W
R121	1-216-825-11	METAL CHIP	2.2K 5% 1/16W
R201	1-216-841-11	METAL CHIP	47K 5% 1/16W
R202	1-216-841-11	METAL CHIP	47K 5% 1/16W

AUDIO

Ref. No.	Part No.	Description	Remark
R203	1-216-821-11	METAL CHIP	1K 5% 1/16W
R204	1-216-821-11	METAL CHIP	1K 5% 1/16W
R205	1-216-856-11	METAL CHIP	820K 5% 1/16W
R206	1-216-840-11	METAL CHIP	39K 5% 1/16W
R207	1-216-843-11	METAL CHIP	68K 5% 1/16W
R208	1-216-820-11	METAL CHIP	820 5% 1/16W
R209	1-216-825-11	METAL CHIP	2.2K 5% 1/16W
R210	1-216-824-11	METAL CHIP	1.8K 5% 1/16W
R211	1-216-845-11	METAL CHIP	100K 5% 1/16W
R212	1-216-839-11	METAL CHIP	33K 5% 1/16W
R213	1-216-838-11	METAL CHIP	27K 5% 1/16W
R214	1-216-994-11	METAL GLAZE	13K 5% 1/16W
R215	1-216-852-11	METAL CHIP	390K 5% 1/16W
R216	1-216-840-11	METAL CHIP	39K 5% 1/16W
R217	1-216-793-11	METAL GLAZE	4.7 5% 1/16W
R218	1-216-821-11	METAL CHIP	1K 5% 1/16W
R221	1-216-825-11	METAL CHIP	2.2K 5% 1/16W
R303	1-216-836-11	METAL CHIP	18K 5% 1/16W
R304	1-216-842-11	METAL CHIP	56K 5% 1/16W
R305	1-216-825-11	METAL CHIP	2.2K 5% 1/16W
R306	1-216-845-11	METAL CHIP	100K 5% 1/16W
R307	1-216-841-11	METAL CHIP	47K 5% 1/16W
R308	1-216-845-11	METAL CHIP	100K 5% 1/16W
R309	1-216-845-11	METAL CHIP	100K 5% 1/16W
R310	1-216-851-11	METAL CHIP	330K 5% 1/16W
R311	1-216-839-11	METAL CHIP	33K 5% 1/16W
R312	1-216-830-11	METAL CHIP	5.6K 5% 1/16W
R313	1-216-839-11	METAL CHIP	33K 5% 1/16W
R314	1-216-830-11	METAL CHIP	5.6K 5% 1/16W
R315	1-216-833-11	METAL CHIP	10K 5% 1/16W
R401	1-216-817-11	METAL CHIP	470 5% 1/16W
R402	1-216-837-11	METAL CHIP	22K 5% 1/16W
R403	1-216-813-11	METAL CHIP	220 5% 1/16W
R404	1-216-813-11	METAL CHIP	220 5% 1/16W
R405	1-216-837-11	METAL CHIP	22K 5% 1/16W
R406	1-216-821-11	METAL CHIP	1K 5% 1/16W
R407	1-216-815-11	METAL CHIP	330 5% 1/16W
R601	1-216-815-11	METAL CHIP	330 5% 1/16W
R602	1-216-849-11	METAL CHIP	220K 5% 1/16W
R603	1-216-833-11	METAL CHIP	10K 5% 1/16W
R604	1-216-834-11	METAL CHIP	12K 5% 1/16W
R605	1-216-821-11	METAL CHIP	1K 5% 1/16W
R606	1-216-829-11	METAL CHIP	4.7K 5% 1/16W
R610	1-216-821-11	METAL CHIP	1K 5% 1/16W
R701	1-216-853-11	METAL GLAZE	470K 5% 1/16W (EX50)
R702	1-216-851-11	METAL GLAZE	2.2M 5% 1/16W (EX50)
R703	1-216-853-11	METAL GLAZE	470K 5% 1/16W (EX50)
R704	1-216-851-11	METAL GLAZE	2.2M 5% 1/16W (EX50)
R705	1-216-853-11	METAL GLAZE	470K 5% 1/16W (EX50)

Ref. No.	Part No.	Description	Remark
R706	1-216-861-11	METAL GLAZE	2.2M 5% 1/16W (EX50)
R707	1-216-853-11	METAL GLAZE	470K 5% 1/16W (EX50)
R708	1-216-861-11	METAL GLAZE	2.2M 5% 1/16W (EX50)
R709	1-216-821-11	METAL GLAZE	1K 5% 1/16W (EX50)
R802	1-216-839-11	METAL CHIP	33K 5% 1/16W (FX50)
R803	1-216-830-11	METAL CHIP	5.6K 5% 1/16W (FX50)
R804	1-216-833-11	METAL CHIP	10K 5% 1/16W (FX50)
R805	1-216-839-11	METAL CHIP	33K 5% 1/16W (FX50)
R806	1-216-830-11	METAL CHIP	5.6K 5% 1/16W (FX50)
R807	1-216-831-11	METAL CHIP	6.8K 5% 1/16W (FX50)
R808	1-216-831-11	METAL CHIP	6.8K 5% 1/16W (FX50)
R809	1-216-815-11	METAL CHIP	330 5% 1/16W (FX50)
R810	1-216-825-11	METAL CHIP	2.2K 5% 1/16W (FX50)
R811	1-216-845-11	METAL CHIP	100K 5% 1/16W (FX50)

< VARIABLE RESISTOR >

RV301	1-241-526-11	RES. VAR. CARBON 10K/10K (VOLUME)
RV601	1-237-002-11	RES. ADJ. METAL GLAZE 2.2K (SPEED)

< SWITCH >

S301	1-571-275-11	SWITCH, SLIDE (TAPE)
S302	1-571-275-31	SWITCH, SLIDE (DOLBY NR)
S303	1-571-506-11	SWITCH, SLIDE (MEGA BASS)
S701	1-572-288-11	SWITCH, PUSH (FF) (EX50)
S702	1-572-288-11	SWITCH, PUSH (REW) (EX50)
S901	1-571-585-11	SWITCH, PUSH (1 KEY) (POWER)
S902	1-571-585-11	SWITCH, PUSH (1 KEY) (PLAY)
S903	1-571-585-11	SWITCH, PUSH (1 KEY) (FWD/RVS)

< SOCKET >

W701	1-580-482-11	SOCKET, CONNECTOR 7P (EX50)
W801	1-568-253-21	HOUSING, CONNECTOR 7P (FX50)

TUNER

FLEXIBLE

Ref. No.	Part No.	Description	Remark
--- WM-FX50 ONLY ---			
	A-3016-050-A	TUNER BOARD, COMPLETE (AEP, E)	
	A-3016-055-A	TUNER BOARD, COMPLETE (US, Canadian)	

	1-638-316-11	FLEXIBLE BOARD	

< CAPACITOR >			
C3	1-162-995-11	CERAMIC CHIP 0.022uF	50V
C4	1-162-977-11	CERAMIC CHIP 0.0018uF	10% 50V
C5	1-164-173-11	CERAMIC CHIP 0.0039uF	10% 50V
C6	1-162-961-11	CERAMIC CHIP 330PF	10% 50V
C8	1-135-091-00	TANTALUM CHIP 1uF	20% 16V
C9	1-163-105-00	CERAMIC CHIP 33PF	5% 50V
C10	1-164-433-11	CERAMIC CHIP 6PF	0.5PF 50V
C11	1-162-995-11	CERAMIC CHIP 0.022uF	50V
C12	1-162-964-11	CERAMIC CHIP 0.001uF	10% 50V
C13	1-135-149-21	TANTALUM CHIP 2.2uF	20% 10V
C14	1-135-151-21	TANTALUM CHIP 4.7uF	20% 4V
C15	1-164-346-11	CERAMIC CHIP 1uF	16V
C16	1-135-201-11	TANTALUM CHIP 10uF	20% 4V
C17	1-164-346-11	CERAMIC CHIP 1uF	16V
C18	1-162-967-11	CERAMIC CHIP 0.0033uF	10% 50V
C19	1-164-222-11	CERAMIC CHIP 0.22uF	25V
C20	1-162-967-11	CERAMIC CHIP 0.0033uF	10% 50V
C21	1-162-625-11	CERAMIC CHIP 0.0047uF	5% 50V
C22	1-164-346-11	CERAMIC CHIP 1uF	16V
C23	1-164-222-11	CERAMIC CHIP 0.22uF	25V
C24	1-164-346-11	CERAMIC CHIP 1uF	16V
C25	1-164-238-11	CERAMIC CHIP 36PF	10% 50V
C26	1-135-151-21	TANTALUM CHIP 4.7uF	20% 4V
C27	1-135-201-11	TANTALUM CHIP 10uF	20% 4V
C28	1-163-205-00	CERAMIC CHIP 0.001uF	5% 50V
C29	1-162-964-11	CERAMIC CHIP 0.001uF	10% 50V
C30	1-162-964-11	CERAMIC CHIP 0.001uF	10% 50V
C31	1-135-202-21	TANTALUM CHIP 22uF	20% 4V
C32	1-164-005-11	CERAMIC CHIP 0.47uF	25V
C33	1-164-005-11	CERAMIC CHIP 0.47uF	25V
C34	1-135-201-11	TANTALUM CHIP 10uF	20% 4V
C35	1-135-201-11	TANTALUM CHIP 10uF	20% 4V
C36	1-164-222-11	CERAMIC CHIP 0.22uF	25V
C37	1-162-997-11	CERAMIC CHIP 10PF	50V (AEP, E)
C37	1-162-936-11	CERAMIC CHIP 5PF	50V (US, Canadian)
C38	1-162-998-11	CERAMIC CHIP 22PF	5% 50V
C40	1-164-428-91	CERAMIC CHIP 1PF	0.25PF 50V
C45	1-135-201-11	TANTALUM CHIP 10uF	20% 4V
C46	1-135-201-11	TANTALUM CHIP 10uF	20% 4V

Ref. No.	Part No.	Description	Remark
C47	1-164-362-11	CERAMIC CHIP 470PF	50V
C48	1-162-966-11	CERAMIC CHIP 0.0022uF	10% 50V
C49	1-162-964-11	CERAMIC CHIP 0.001uF	10% 50V
C50	1-162-995-11	CERAMIC CHIP 0.022uF	50V
C51	1-164-346-11	CERAMIC CHIP 1uF	16V
C52	1-162-995-11	CERAMIC CHIP 0.022uF	50V
C53	1-164-156-11	CERAMIC CHIP 0.1uF	25V
C54	1-162-953-11	CERAMIC CHIP 100PF	5% 50V
C55	1-164-174-11	CERAMIC CHIP 0.0082uF	10% 25V
C56	1-135-201-11	TANTALUM CHIP 10uF	20% 4V
C57	1-162-995-11	CERAMIC CHIP 0.022uF	50V
C59	1-162-995-11	CERAMIC CHIP 0.022uF	50V
C60	1-135-201-11	TANTALUM CHIP 10uF	20% 4V
C61	1-164-173-11	CERAMIC CHIP 0.0039uF	10% 50V
C62	1-164-222-11	CERAMIC CHIP 0.22uF	25V
C63	1-163-185-00	CERAMIC CHIP 150PF	5% 50V
C64	1-163-140-00	CERAMIC CHIP 910PF	5% 50V
< TRIMMER >			
CT1	1-141-327-11	CAP, VAR, TRIMMER (CHIP TYPE)	(AM FREQ. COVER)
CT2	1-141-327-11	CAP, VAR, TRIMMER (CHIP TYPE)	(AM TRACKING)
CT3	1-141-325-11	CAP, VAR, TRIMMER (CHIP TYPE)	(FM FREQ. COVER)
< DIODE >			
D1	8-719-951-05	DIODE KV1560	
D2	8-719-939-02	DIODE SVC203CP	
D3	8-719-939-02	DIODE SVC203CP	
D4	8-719-420-51	DIODE MA729	
D5	8-719-420-51	DIODE MA729	
D6	8-719-420-51	DIODE MA729	
D7	8-719-420-51	DIODE MA729	
D8	8-719-420-51	DIODE MA729	
D9	8-719-800-76	DIODE 1SS226	
D50	8-719-421-21	DIODE MA8120-L	
D51	8-719-404-46	DIODE MA110	
D52	8-719-800-76	DIODE 1SS226	
< FILTER >			
FL1	1-239-015-21	FILTER, BAND PASS	
< IC >			
IC1	8-752-050-43	IC CXA1129N	

FLEXIBLE DISPLAY PANEL BLOCK

Ref. No.	Part No.	Description	Remark
< RESISTOR >			
JR1-JR25	1-216-296-00	METAL CHIP	0 5% 1/8W
JR30-JR55	1-216-864-11	METAL CHIP	0
< COIL >			
L1	1-412-764-21	COIL (AM OSC)	
L2	1-402-551-11	ANTENNA, FERRITE-ROD (LW)	
L3	1-412-765-21	COIL (FM OSC)	
L5	1-412-763-21	COIL (VCO)	
L6	1-412-762-21	COIL (2ND OSC)	
L7	1-410-983-31	INDUCTOR CHIP	0.15uH
L9	1-410-209-51	INDUCTOR CHIP	27uH
L50	1-412-011-31	INDUCTOR CHIP	27uH
L51	1-412-011-31	INDUCTOR CHIP	27uH
< TRANSISTOR >			
Q1	8-729-421-26	TRANSISTOR	UN5214
Q4	8-729-403-17	TRANSISTOR	XN1215
Q5	8-729-344-16	TRANSISTOR	2SD2228-T1D44045
Q6	8-729-402-96	TRANSISTOR	UN5114
Q7	8-729-421-74	TRANSISTOR	UN5210-0
Q8	8-729-421-23	TRANSISTOR	XN1216
Q11	8-729-422-54	TRANSISTOR	XN4215-TW
Q50	8-729-807-87	TRANSISTOR	2SB1295-UL6
Q51	8-729-100-66	TRANSISTOR	2SC1623-L6
Q52	8-729-159-64	TRANSISTOR	2SD596-VD4
Q54	8-729-403-42	TRANSISTOR	XN1401
Q55	8-729-421-23	TRANSISTOR	XN1216
Q56	8-729-421-23	TRANSISTOR	XN1216
Q57	8-729-220-93	TRANSISTOR	2SK209-6
< RESISTOR >			
R1	1-216-833-11	METAL CHIP	10K 5% 1/16W
R2	1-216-853-11	METAL CHIP	470K 5% 1/16W
R3	1-216-853-11	METAL CHIP	470K 5% 1/16W
R4	1-216-853-11	METAL CHIP	470K 5% 1/16W
R5	1-216-813-11	METAL CHIP	220 5% 1/16W
R6	1-216-853-11	METAL CHIP	470K 5% 1/16W
R8	1-216-800-11	METAL GLAZE	18 5% 1/16W
R9	1-216-843-11	METAL CHIP	68K 5% 1/16W
R10	1-216-828-11	METAL CHIP	3.9K 5% 1/16W
R13	1-216-853-11	METAL CHIP	470K 5% 1/16W
R15	1-216-845-11	METAL CHIP	100K 5% 1/16W
R16	1-216-853-11	METAL CHIP	470K 5% 1/16W
R17	1-216-845-11	METAL CHIP	100K 5% 1/16W
R20	1-216-819-11	METAL CHIP	680 5% 1/16W
R21	1-216-829-11	METAL CHIP	4.7K 5% 1/16W

Ref. No.	Part No.	Description	Remark
R22	1-216-829-11	METAL CHIP	4.7K 5% 1/16W
R23	1-216-845-11	METAL CHIP	100K 5% 1/16W
R24	1-216-845-11	METAL CHIP	100K 5% 1/16W
R25	1-216-833-11	METAL CHIP	10K 5% 1/16W
R50	1-216-833-11	METAL CHIP	10K 5% 1/16W
R51	1-216-821-11	METAL CHIP	1K 5% 1/16W
R52	1-216-821-11	METAL CHIP	1K 5% 1/16W
R53	1-216-833-11	METAL CHIP	10K 5% 1/16W
R54	1-216-833-11	METAL CHIP	10K 5% 1/16W
R55	1-216-825-11	METAL CHIP	2.2K 5% 1/16W
R56	1-216-830-11	METAL CHIP	5.6K 5% 1/16W
R57	1-216-831-11	METAL CHIP	6.8K 5% 1/16W
R58	1-216-845-11	METAL CHIP	100K 5% 1/16W
R59	1-216-833-11	METAL CHIP	10K 5% 1/16W
R60	1-216-839-11	METAL CHIP	33K 5% 1/16W

< VARIABLE RESISTOR >

RV51	1-241-414-11	TUNING BLOCK (TUNING)
RV53	1-238-094-11	RES. ADJ CERMET 220K (1.1V ADJ)

< SWITCH >

S1	1-571-275-31	SWITCH, SLIDE (BAND)
S2	1-571-506-41	SWITCH, SLIDE (TAPE/RADIO)
S3	1-571-120-11	SWITCH, SLIDE (FM SENS)

< TRANSFORMER >

T3	1-448-302-11	TRANSFORMER, DC-DC CONVERTER
----	--------------	------------------------------

--- WM-EX50 ONLY ---

1-809-282-11 DISPLAY PANEL BLOCK, LIQUID CRYSTAL

1-638-314-11 FLEXIBLE BOARD, TUNER

< TERMINAL >

TM501	3-367-808-01	TERMINAL (+), BATTERY
TM502	3-367-809-01	TERMINAL BOARD (-), BATTERY

MISCELLANEOUS

334	1-638-313-11	PC BOARD, MOTOR FLEXIBLE
HP901	1-543-812-11	HEAD, MAGNETIC (PLAYBACK)
M901	1-541-660-11	MOTOR

Ref. No.	Part No.	Description	Remark
----------	----------	-------------	--------

ACCESSORY & PACKING MATERIAL

	X-3329-657-1	ATTACHMENT ASSY (FOR MDR-E552) (EX50:AEP, UK, E)	
	1-528-221-21	BATTERY CHARGER (BC-7F) (US)	
	1-528-231-11	BATTERY, NICKEL CADMIUM (NC-6WM) (US, Canadian)	
	1-528-322-11	BATTERY CHARGER (BC-7AC) (Canadian)	
*	3-367-386-01	CUSHION (UPPER) (EX50)	
*	3-367-386-01	CUSHION (UPPER) (FX50)	
*	3-367-387-01	CUSHION (LOWER)	
* 3-367-384-01	INDIVIDUAL CARTON (EX50:US)		
* 3-367-388-01	INDIVIDUAL CARTON (EX50:AEP, UK)		
* 3-367-390-01	INDIVIDUAL CARTON (EX50:E)		
* 3-367-394-01	INDIVIDUAL CARTON (EX50:Canadian)		
* 3-367-398-01	INDIVIDUAL CARTON (EX50:US)		
* 3-367-400-01	INDIVIDUAL CARTON (EX50:AEP)		
* 3-367-401-01	INDIVIDUAL CARTON (EX50:E)		
	3-368-052-01	CASE, CARRYING (EX50)	
	3-368-053-01	CASE, CARRYING (EX50)	
	3-753-019-11	MANUAL, INSTRUCTION (FOR MDR-E552) (ENGLISH, FRENCH, SPANISH, PORTUGUESE) (EX50:AEP, UK, E)	
	3-753-019-21	MANUAL, INSTRUCTION (ENGLISH) (EX50:US)	
	3-753-019-41	MANUAL, INSTRUCTION (FOR MDR-E552) (GERMAN, DUTCH, SWEDISH, ITALIAN) (EX50:AEP)	
	3-753-019-51	MANUAL, INSTRUCTION (FOR MDR-14) (ENGLISH, FRENCH, SPANISH, PORTUGUESE) (EX50:AEP)	
	3-753-019-61	MANUAL, INSTRUCTION (FOR MDR-14) (GERMAN, DUTCH, SWEDISH, ITALIAN) (EX50:AEP)	
	3-753-020-11	MANUAL, INSTRUCTION (ENGLISH, FRENCH, SPANISH, PORTUGUESE) (EX50:AEP, E)	
	3-753-020-21	MANUAL, INSTRUCTION (ENGLISH) (EX50:US)	
	3-753-020-31	MANUAL, INSTRUCTION (FRENCH) (EX50:Canadian)	
	3-753-020-41	MANUAL, INSTRUCTION (GERMAN, DUTCH, SWEDISH, ITALIAN) (EX50:AEP)	
	8-953-341-90	HEADPHONE MDR-14 SET (US, AEP)	
	8-953-400-90	HEADPHONE MDR-E552 SET (AEP, UK, E, Canadian)	

ADJUSTMENTS

Mechanical measurements

Precaution

1. Clean the following parts with a denatured-alcohol-moistened swab :
 - playback head pinch roller
 - capstan rubber belts
2. Demagnetize the playback head with a head demagnetizer.
3. Do not use a magnetized screwdriver for the adjustments.
4. After the adjustments, apply suitable locking compound to the parts adjusted.
5. The adjustments should be performed with the rated power supply voltage (1.3V) unless otherwise noted.

The following measurements are necessary when tape running problems are occurred or repaired the tape transport mechanism.

Torque Measurement

Mode	Torque meter	Meter reading
FWD	CQ-102C	20 - 38 g-cm (0.28 - 0.52 oz-inch)
FWD Back Tension		0.5 - 4 g-cm (0.007 - 0.05 oz-inch)
REV	CQ-102RC	20 - 38 g-cm (0.28 - 0.52 oz-inch)
REV Back Tension		0.5 - 3.5 g-cm (0.007 - 0.05 oz-inch)
FF, REW	CQ-201B	More than 60 g-cm (more than 0.83 oz-inch)

Tape Tension Measurement

Mode	Torque meter	Meter reading
FWD	CQ-403A	More than 40 g-cm (more than 0.56 oz-inch)
RVS	CQ-403R	

W w and Flutter Measurement

procedure :

Function : Tape (WM-FX50)

Mode : Forward

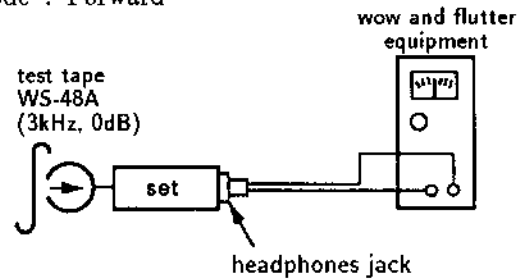

Playback the center part of the test tape (WS-48A) and measure the wow and flutter at the unweighted position of the wow and flutter equipment.

Specification : Less than 0.6% rms (JIS)

Mechanical adjustments

Precaution

- Supplied voltage : 1.3V
- Switch and control position
 - DOLBY NR switch : OFF
 - TAPE switch : NORM
 - MEGA BASS switch : NORM
 - VOLUME control : maximum

Tape section

Tape speed adjustment

Adjustment Location

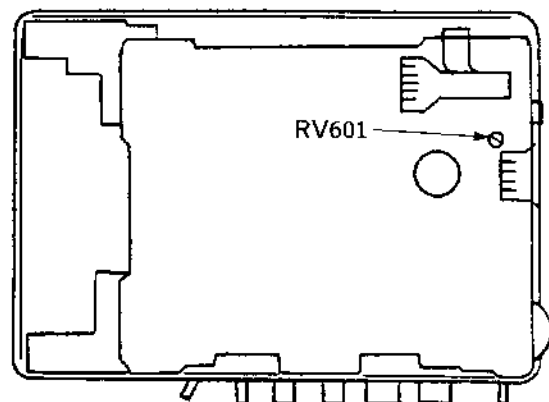

Procedure :

Function : TAPE

Mode : Forward

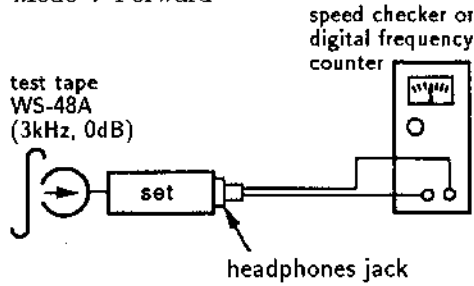

Playback the center part of the test tape (WS-48A) and adjust RV601 to obtain the tape speed to the following value.

Reading on speed checker	Reading on digital frequency counter
$\pm 1.0\%$	3,000Hz ± 30 Hz

Specification :

Frequency difference between the beginning and the end of test tape should be within $\pm 3\%$ (± 90 Hz) after adjusted the tape speed.

Electrical alignments

Tuner Section ONLY for WM-FX50

Adjustment Location

TUNER BOARD

— Component Side —

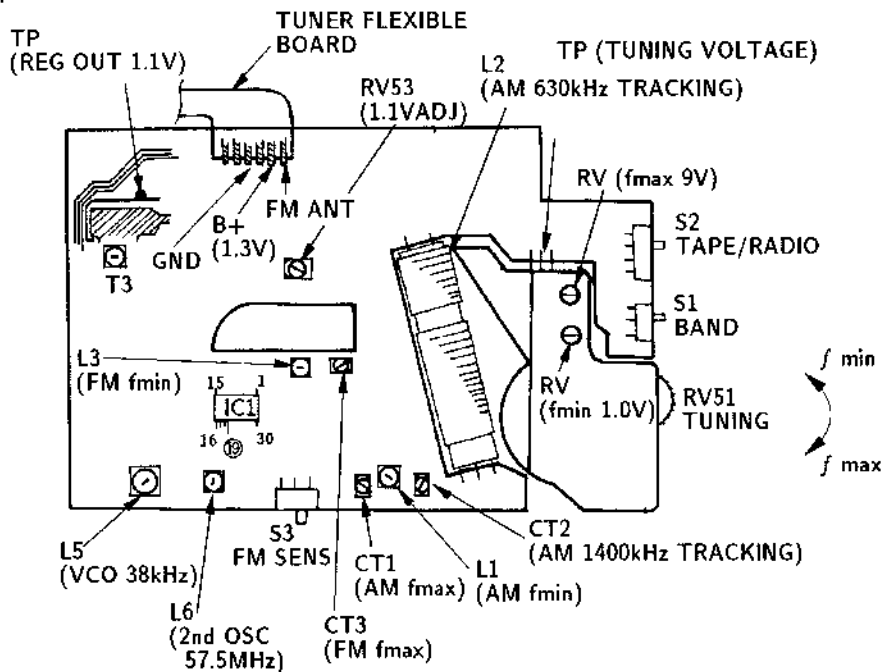

Power Supply Voltage Adjustment

Function switch : RADIO FM ST
Band switch : FM

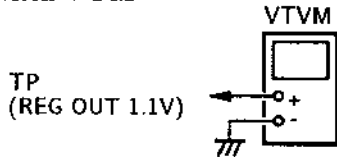

Adjustment part	Reading on VTVM
RV53	$1.1 \pm 0.01V$

Tuning Voltage Adjustment

Function switch : RADIO FM ST
Band switch : FM

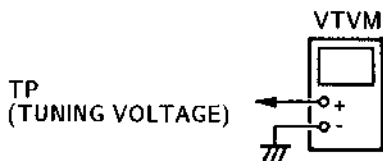

- Repeat the procedure in each adjustment several times since RV (*f min*) affects RV (*f max*) and RV (*f max*) affects RV (*f min*). This adjustment should end with the final adjustment of RV (*f max*).

Pointer position	Adjustment part	Reading on VTVM
<i>f minimum</i>	RV (<i>fmin</i> 1.0V)	$1V \pm 0.01V$
<i>f maximum</i>	RV (<i>fmax</i> 9V)	$9V \pm 0.01V$

Note :

RV (*f min*), RV (*f max*) is built-in the RV51 block.

FM VCO Adjustment

FM rf signal generator (SG)

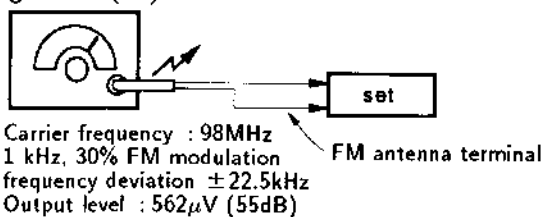

Function switch : RADIO FM ST

Band switch : FM

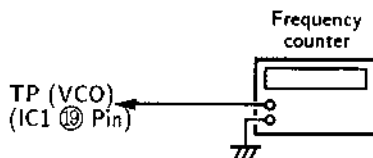

- Tune the set to 98 MHz.

Adjustment part	frequency counter
L5	$38kHz \pm 0.02kHz$

FM 2nd OSC Adjustment

Function switch : RADIO FM ST

Band Switch : FM

Adjustment part : L6

- How to adjust FM 2nd. oscillator using the spectrum analyzer.

- Prepared the spectrum analyzer and RF amplifier as shown in below drawing.
- Set the switch to radio FM stereo position of WM-FX50.
- Put the RF amplifier block which connected to spectrum analyzer to just beside and one centimeter away from L6.
- Adjust L6 to bring up maximum waveform at 57.5 MHz position in spectrum analyzer.

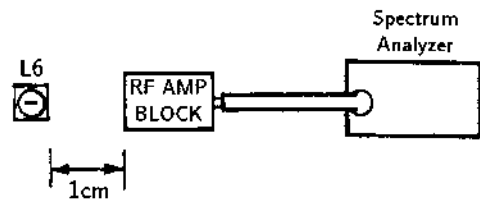

- How to adjust FM 2nd. oscillator if the spectrum analyzer is not available.

- Prepared built-in SSB digital tuning radio such as SONY ICF-2001 or equivalents.
- Tuned $57.5MHz \pm 0.1MHz$ at the SSB mode of built-in SSB digital tuning radio.
- Set the switch to radio FM stereo position of WM-FX50.
- Put the telescopic antenna of built-in SSB digital tuning radio to just beside and one centimeter away from L6 as show in below drawing.
- Digital tuning radio will be reproduce peep sound.
- Adjust L6 to fade out or minimize peep sound.

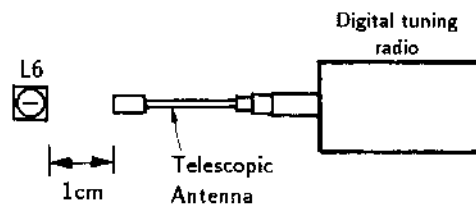

FM Frequency Coverage Adjustment

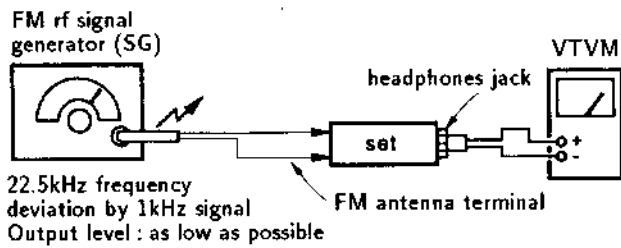

Function switch : RADIO FM ST

Band switch : FM

- Repeat the procedure in each adjustment several times since L3 affects CT3 and CT3 affects L3. This adjustment should end with the final adjustment of CT3.

Pointer position	SG frequency	Adjustment part	Reading on VTVM
f minimum	86.5 MHz	L3	maximum
f maximum	109.5 MHz	CT3	maximum

AM Frequency Coverage Adjustment

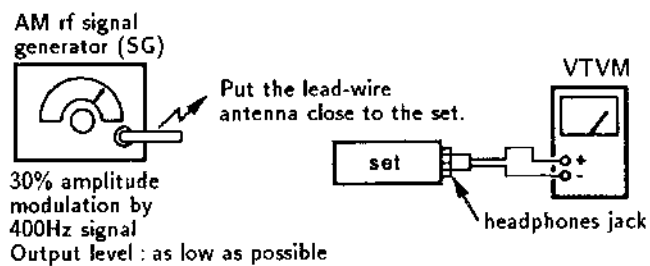

Function switch : RADIO FM ST

Band switch : AM

- Repeat the procedure in each adjustment several times since L1 affects CT1 and CT1 affects L1. This adjustment should end with the final adjustment of CT1.

Pointer position	SG frequency	Adjustment part	Reading on VTVM
f minimum	520kHz \pm 3kHz	L1	maximum
f maximum	1680kHz \pm 20kHz (1750kHz \pm 20kHz)	CT1	maximum

no mark : except US, Canadian model
() : US, Canadian model

AM Tracking Adjustment

Function switch : RADIO FM ST

Band switch : AM

- Repeat the procedure in each adjustment several times since L2 affects CT2 and CT2 affects L2. This adjustment should end with the final adjustment of CT2.

SG and set frequency	Adjustment part	Reading on VTVM
630kHz	L2	maximum
1400kHz	CT2	

NOTE :

Test equipment is settled as same as AM Frequency coverage adjustment.

Specifications

Radio (WM-FX50 only) In Italy
 FM : 87.5 - 108MHz
 AM : 526.5 - 1,606.5kHz
 In other countries
 FM : 87.6 - 107.9MHz
 AM : 531 - 1,602kHz

Power requirements 1.5V DC
 One R6 (size AA) battery
 Rechargeable battery
 DC1.5V jack accepts
 Sony AC-E15L AC power adaptor
 (not supplied) for use on :

AEP model	220V AC, 50Hz
E model	120V AC, 60Hz 220V AC, 50Hz
US, Canadian model	120V AC, 60Hz
UK model	240V AC, 50Hz

Power life
 (Approximate hours)

		WM-FX50
	Playback	FM
Sony Alkaline AM3 (N)	7 hrs.	30 hrs.
Rechargeable NC-6WM	3 hrs.	10 hrs.

Design and specifications subject to change without notice.

Note

This appliance conforms with ECC Directive 87/308/ECC regarding interference suppression.

Accessories supplied

○ : supplies × : not supplied

	Stereo headphones	Stereo earphones	Ear adaptors	Carrying case
Italian model	×	○	○	○
Other European model	○	×	×	○
Other model	×	○	○	○

Lithium battery (1) ... WM-EX50 only

Note on stereo earphones (except other European model)

If the earphones do not fit your ears, attach the ear adaptors (supplied).

Note on stereo headphones (European model except Italian model).

The cord of the headphones is detachable. If the cord becomes detached, reconnect it as illustrated.

