

WM-D6C TC-D6C

SERVICE MANUAL

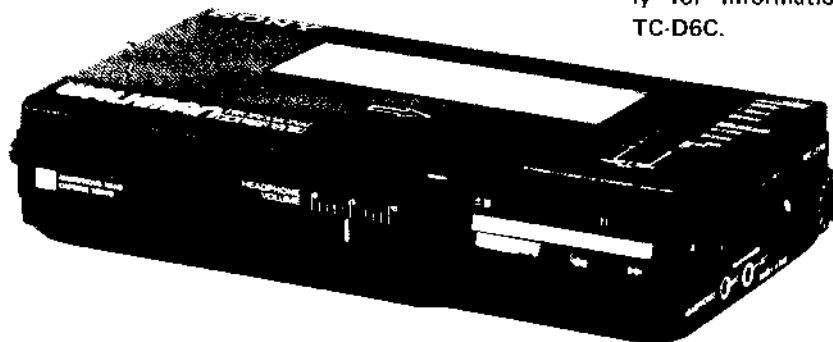

'Dolby' and the double-D symbol are the trade marks of Dolby Laboratories Licensing Corporation. Noise reduction system manufactured under license from Dolby Laboratories Licensing Corporation.

- Refer to MDR-40L Service Manual issued previously for information of headphones supplied with WM-D6C.
- Refer to ECM-939LT Service Manual issued previously for information of headphones supplied with TC-D6C.

WM-D6C:
US Model
Canadian Model
AEP Model
UK Model
E Model

TC-D6C:
US Model

SPECIFICATIONS

Recording System: 4-track, 2-channel stereo

Wow and Flutter: $\pm 0.14\%$ (DIN)
 0.04% WRMS (NAB)

Tape Speed Deviation: $\pm 0.3\%$ (speed tuning OFF)

Speed Tuner
Variations: Approx. $\pm 4\%$

Frequency Response: DOLBY NR OFF
 • With TYPE IV cassette (Sony METALLIC)
 40 – 15,000 Hz ± 3 dB
 • With TYPE II cassette (Sony UCX)
 40 – 15,000 Hz ± 3 dB
 • With TYPE I cassette (Sony BHF or HFX)
 40 – 15,000 Hz ± 3 dB

S/N (NAB, at peak level): DOLBY NR C
 TYPE IV cassette (Sony METALLIC) 71 dB
 TYPE II cassette (Sony UCX) 71 dB
 TYPE I cassette (Sony BHF or HFX) 67 dB
 DOLBY NR B
 TYPE IV cassette (Sony METALLIC) 65 dB
 TYPE II cassette (Sony UCX) 65 dB
 TYPE I cassette (Sony BHF or HFX) 61 dB
 DOLBY NR OFF
 TYPE IV cassette (Sony METALLIC) 58 dB
 TYPE II cassette (Sony UCX) 58 dB
 TYPE I cassette (Sony BHF or HFX) 54 dB

Total Harmonic Distortion: 0.9% with Sony METALLIC

Inputs: MIC (PLUG IN POWER) (stereo minijack) x 1
 0.25 mV (-70 dB) with low impedance microphone
 LINE IN (stereo minijack) x 1
 77.5 mV (-20 dB) (47 kilohms)

Tape Transport Mechanism Type	MT-D6C-20
-------------------------------	-----------

Outputs: LINE OUT (stereo minijack) x 1
 output level 0.25 V (-10 dB) (less than 4.7 kilohms)
 Headphones (stereo minijack) x 1
 load impedance 8 – 300 ohms

Power Output: Headphones
 30 mW + 30 mW (at 10% harmonic distortion)
 load impedance 32 ohms

Battery Life: See page 2.

Power Requirements: 6 V dc, four batteries, IEC designation R6 (size AA)
 BP-23 battery pack (optional)
 External power input jack (required power 6 V dc) accepts Sony ac power adaptor (optional) listed on page 2 for use on appropriate ac power, or Sony DCC-127A car battery cord (optional) for use on 12 V car battery

Dimensions: 181 x 40 x 95 mm (w/h/d)
 (7 $\frac{1}{4}$ x 1 $\frac{5}{8}$ x 3 $\frac{3}{4}$ inches) including projecting parts

Weight: Approx. 640 g (1 lb 7 oz) including batteries

0 dB = 0.775 V



MICROFILM

STEREO CASSETTE-CORDER

SONY®

TC

Battery life

type of cassette batteries	continuous recording		continuous playback
	TYPE IV (Sony METALLIC)	TYPE I (Sony BHF, HFX)	TYPE I, IV (Sony BHF, HFX, METALLIC)
Sony Eveready AM3 alkaline batteries	4	5	6
Sony SUM-3(NS) New Super batteries	2	2.5	3

(hours)

OTHER POWER SOURCES

HOUSE CURRENT

Use the appropriate ac power adaptor listed below, available in the countries where the set is used.

First connect the adaptor to DC IN 6 V jack, and then to a wall outlet.

Before connecting, be sure to read the instruction manual for the adaptor.

location	ac power adaptor	input voltage of adaptor
AEP	AC-66	220 V ac, 50 Hz
	AC-456C	110 or 220 V ac adjustable, 50 Hz
UK	AC-15A	240 V ac, 50 Hz
Canadian	AC-9	120 V ac, 60 Hz
E	AC-4A	110, 120, 220 or 240 V ac adjustable, 50/60 Hz
US	AC-9W	120 V ac, 60 Hz

FEATURES

- **Quartz lock capstan servo system** assures accurate and stable tape speed.
- In addition to the conventional B-type Dolby* NR system, the WM-D6C or TC-D6C employs the **C-type Dolby NR system** which reduces tape noise twice as effectively as the B-type system.
- **Speed control** adjusts the tape speed accurately (approx. $\pm 4\%$) in the playback mode.
- **DC-DC converter** boosts the low voltage of DC 6V and maintains sufficient power.
- **Amorphous head** for recording/playback provides a wider dynamic range and a more extended frequency response.
- **Tape selector** for optimum recording with standard tapes as well as high-performance tapes.
- **Microphone attenuator** eliminates the distortion which may be caused by high-level input signal.
- **MIC (PLUG IN POWER) jack** can supply power to an ECM-102 electret condenser stereo microphone (optional).
- **Four different power sources:** batteries, house current, rechargeable battery pack, and 12 V car battery.
- **5-LED peak/battery indicator** shows both the peak level and the battery strength.
- **Stereo minijacks** can be used for connecting to audio components.

PARTS IDENTIFICATION

- 1 Peak/battery indicator and indication selector
- 2 Tape counter and reset button
- 3 DOLBY NR selector
- 4 TAPE selector
- 5 REC LEVEL (recording level) control
- 6 ● RECORD button
- 7 MIC ATT (microphone attenuator) switch
- 8 MIC (PLUG IN POWER) jack (stereo minijack)
- 9 HEADPHONES jack
- 10 ■■ (pause) button
- 11 ►► (fast forward) CUE button
- 12 ◀◀ (rewind) REVIEW button
- 13 ► PLAY (playback) button
- 14 ▲■ (eject/stop) button
- 15 HEADPHONE VOLUME control
- 16 LINE IN jack
- 17 LINE OUT jack
- 18 SPEED TUNE selector and control
- 19 DC IN 6 V jack

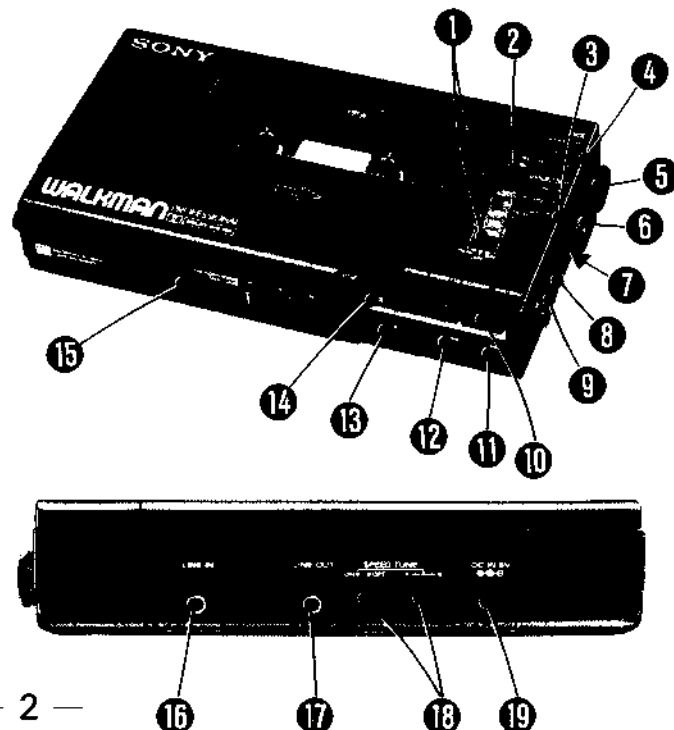

Chip components

Chip components include resistors, capacitors, transistors, diodes, coil and adjustable resistors.

In this section, the types of resistors, ceramic capacitors, transistors and diodes which are used most frequently will be described.

Dimension of transistors and capacitors

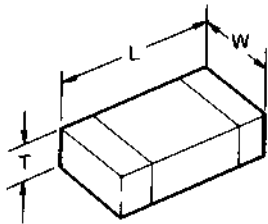

(Unit: mm)

Type	L	W	T
3216	3.2	1.6	0.45 ~ 0.6
2125	2.0	1.25	0.35 ~ 0.5

Identification

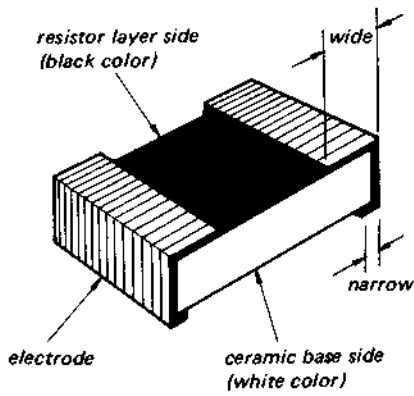

Resistor

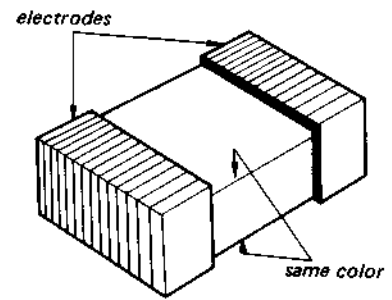

Laminated Ceramic Capacitor

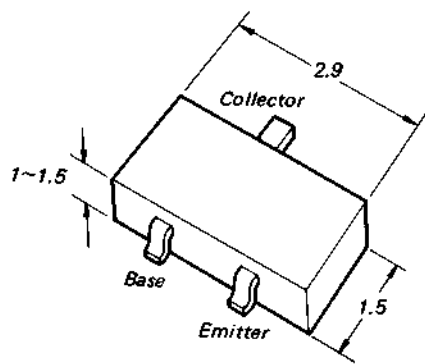

Transistor

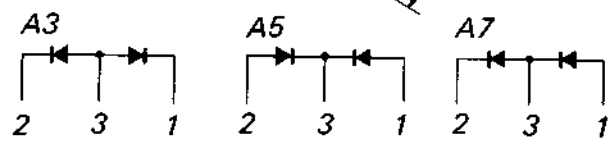
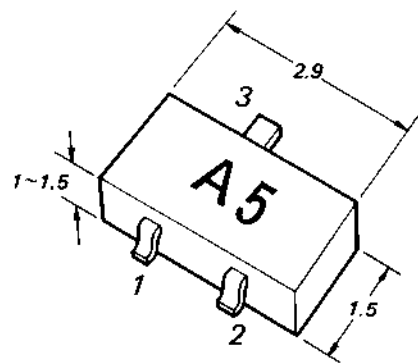

Diode

Replacing chip components

All chip components should be connected and disconnected, using a tapered soldering iron [temperature of the iron tip: less than 280°C (536°F)], a pair of tweezers and braided wire.

Precautions for replacement

1. Do not disconnect the chip component forcefully. Otherwise, the pattern may peel off.
2. Never re-use a disconnected chip component. Dispose of all old chip components.
3. To protect the chip component, heating time for attaching the component should be within 3 seconds.

○ Removing chip components

(1) Removing solder at electrode

Remove the solder at the electrode, using a thin braided wire. Do not remove the solder of the part (chip component) attached adjacent to the electrode.

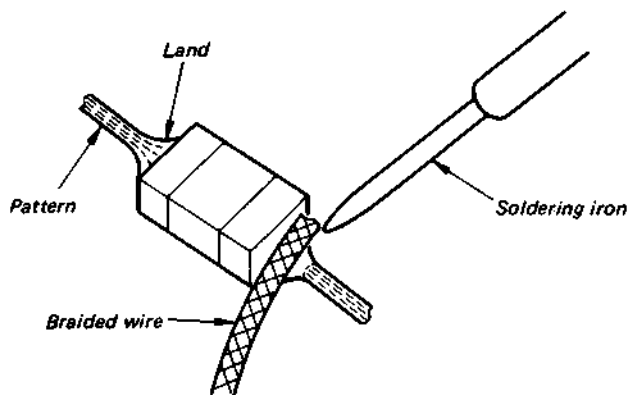

(2) Disconnecting chip components

Turn the tweezers with the soldering iron alternately applied to both electrodes, and the chip component will be disconnected. Take careful precautions while disconnecting, because if the chip component is forcefully removed the land may peel off. Never re-use a disconnected chip component.

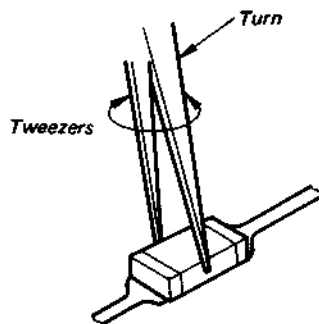

(3) Smoothing the soldered surface

After disconnecting the chip component, remove the solder by using a braided wire to smooth the land surface.

○ Connecting chip components

The value of chip components is not displayed on the main body. Take due precautions to avoid mixing new chip components with other ones.

(1) Applying solder to land on one side

Apply a thin layer of solder to the land on one side where the chip component is to be connected. Too much solder may cause bridging.



(2) Speedy soldering

Hold the chip component at the desired position, using tweezers, and apply the soldering iron in the arrow-marked direction. To protect the chip component, heating time should be within 3 seconds.

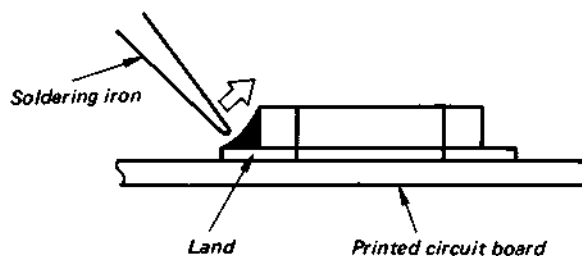

(3) Speedy soldering of electrode on the other side

Solder the electrode on the other side in the same way as in (2) above.

SECTION 1
BLOCK DIAGRAM

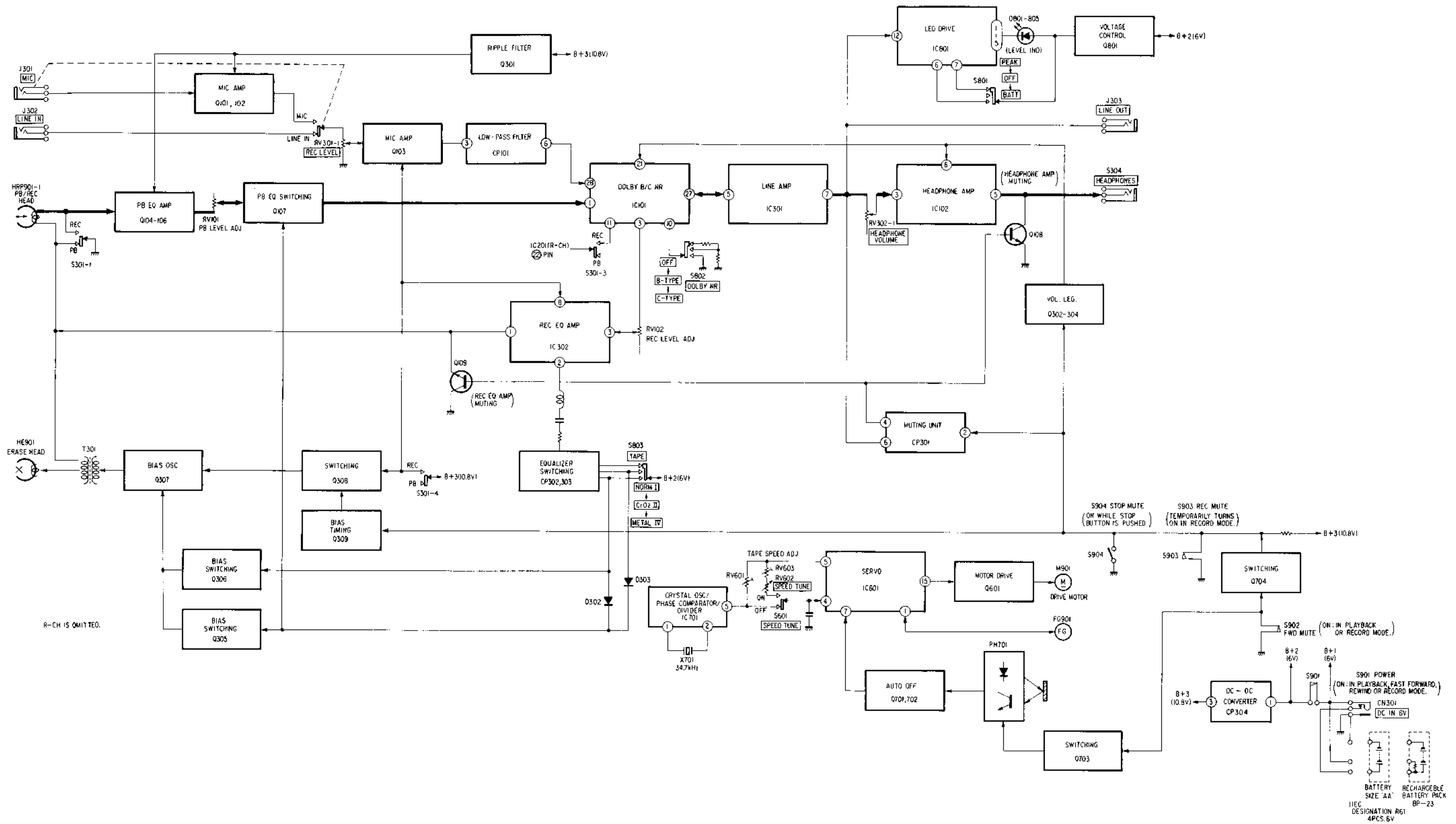

**SECTION 2
DISASSEMBLY**

CASSETTE LID

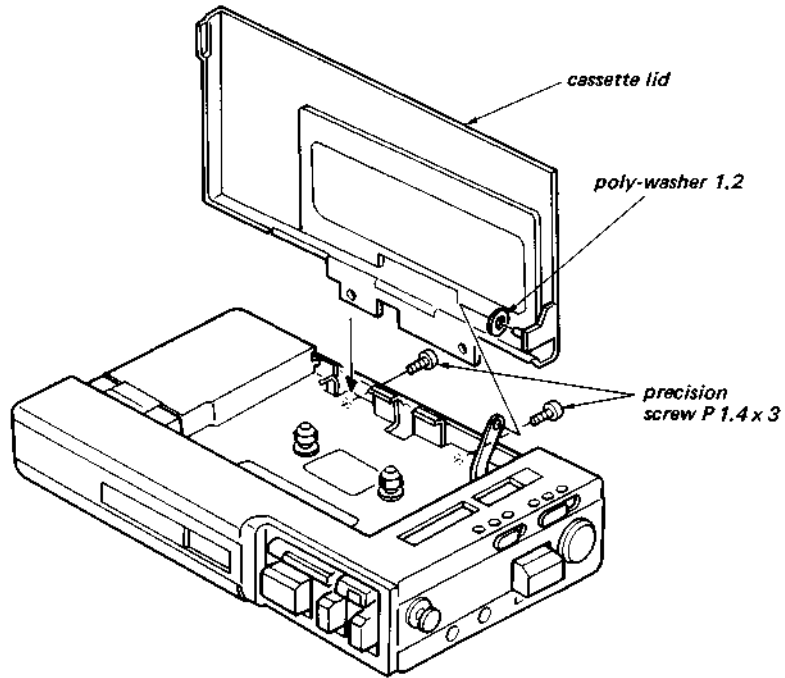

REEL PANEL

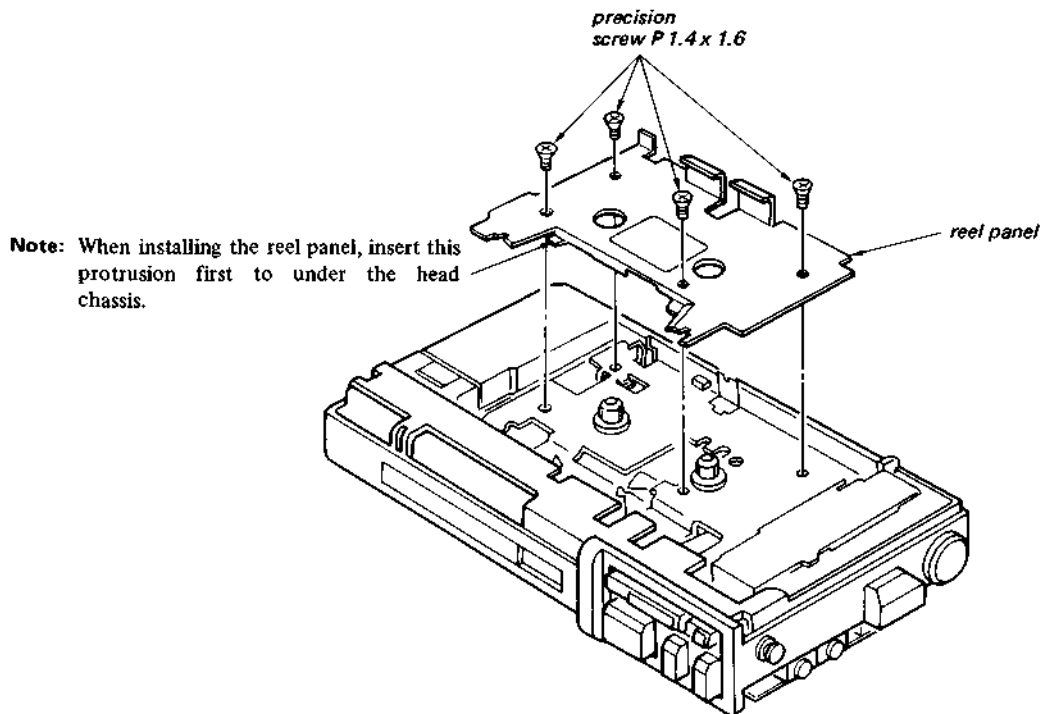

UPPER AND LOWER PANEL

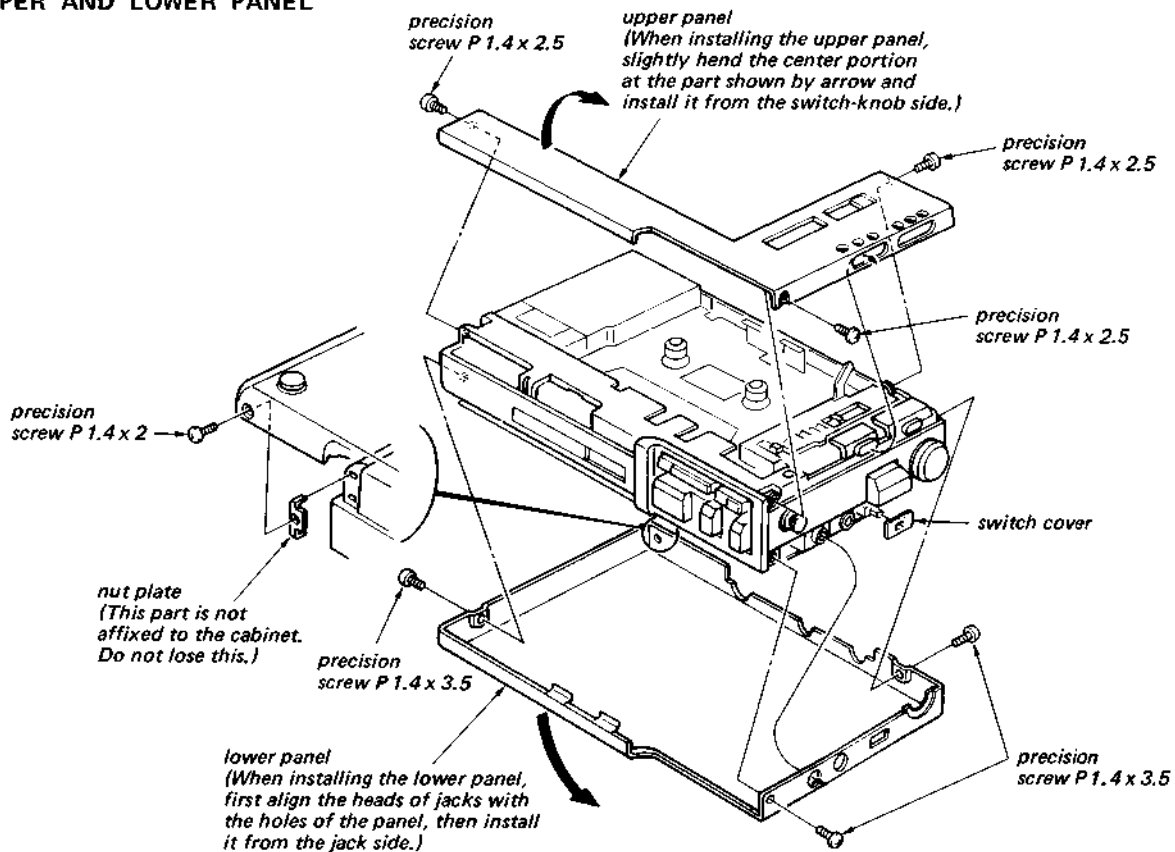

LED HOLDER AND LED BOARD

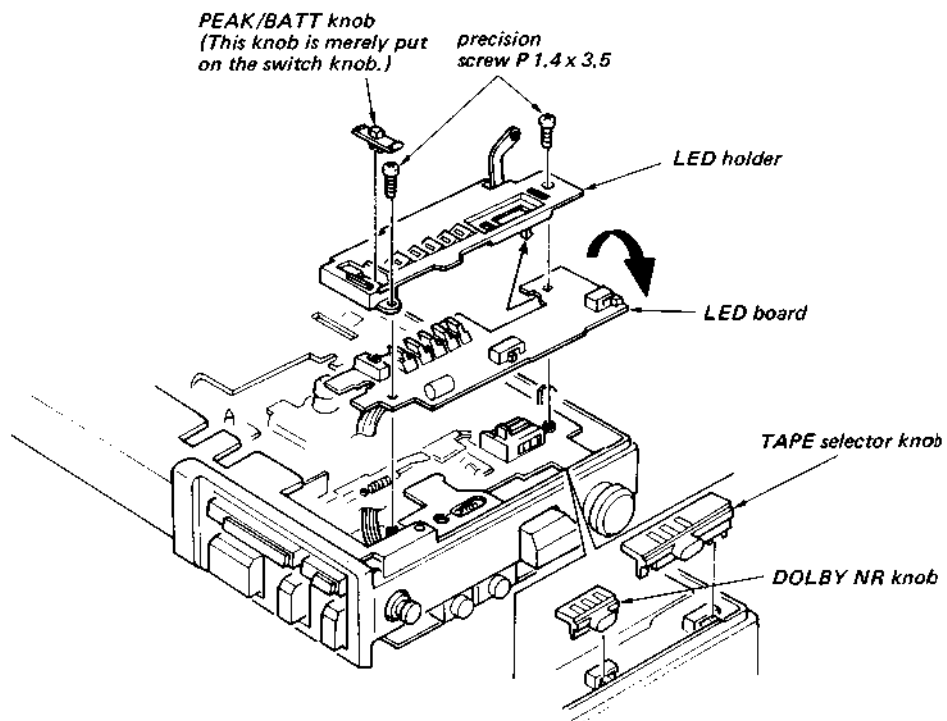

MAIN BOARD

Note: When installing the main board, set VOLUME control knob to "10".

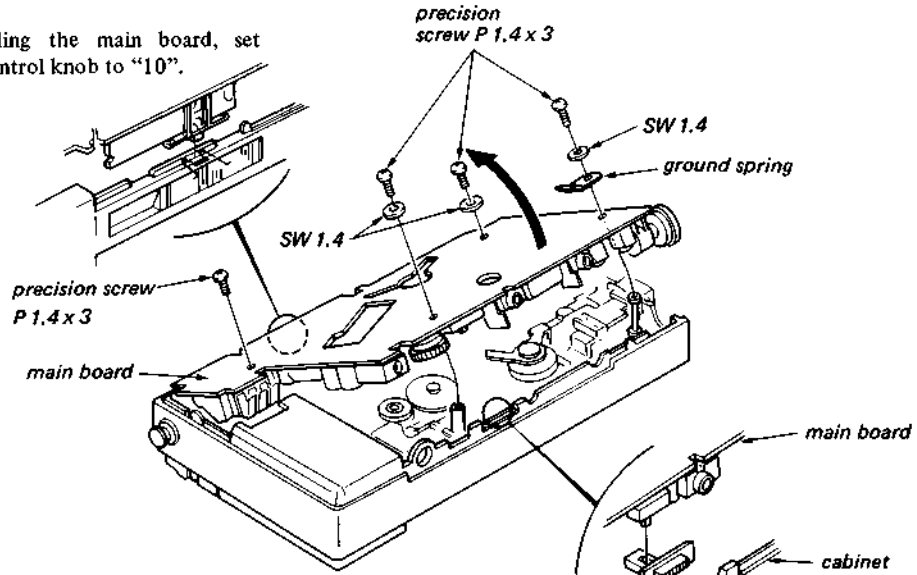

Note: When installing the main board, slightly open the main board and preparatory install SPEED TUNE knob on the slide switch knob, then completely install the main board to the cabinet with groove of SPEED TUNE knob properly set on the edge of the cabinet. And check that the knob smoothly moves and the switch securely operates.

CABINET

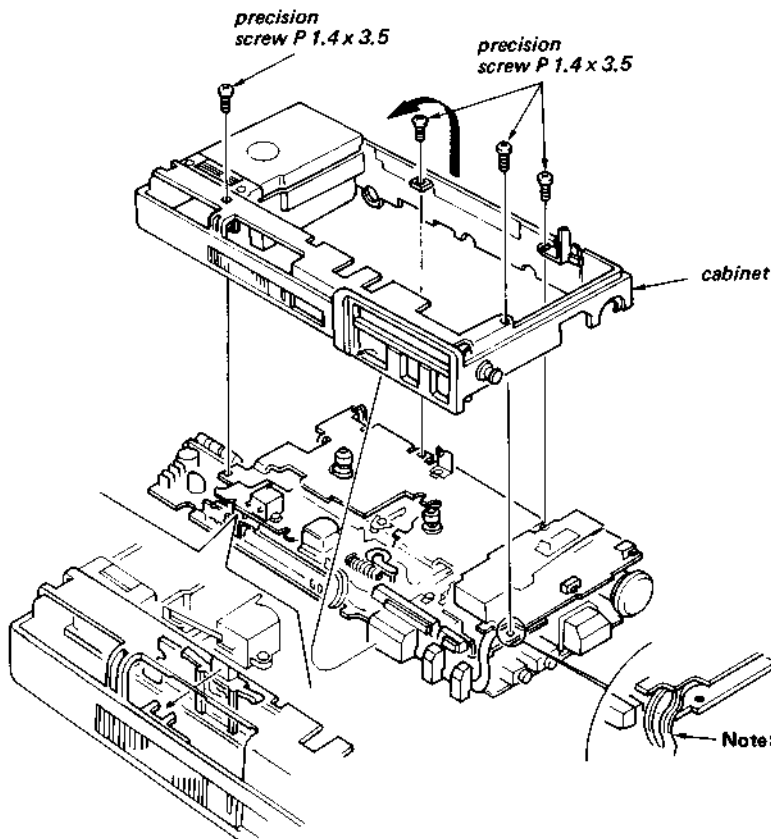

DC-DC BOARD

Note: When C316 is replaced, bend its lead diagonally and lay it on the DC-DC board not to touch components on the main board.

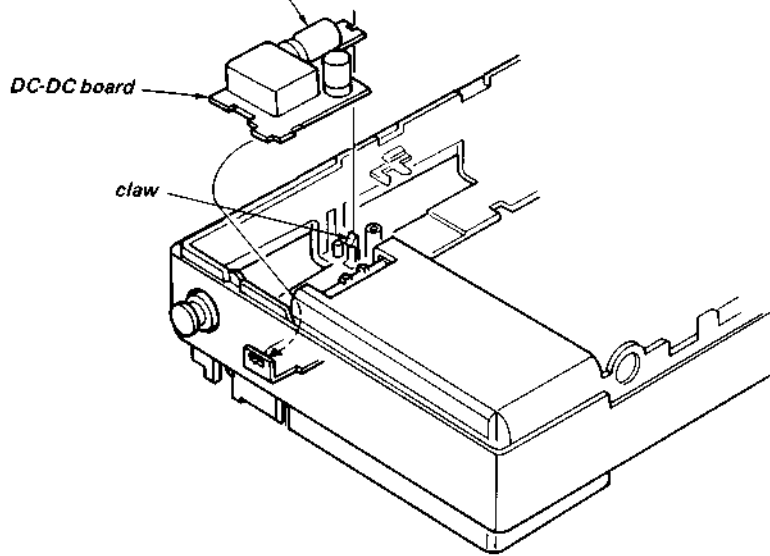

REC/PB, ERASE HEAD AND PINCH LEVER

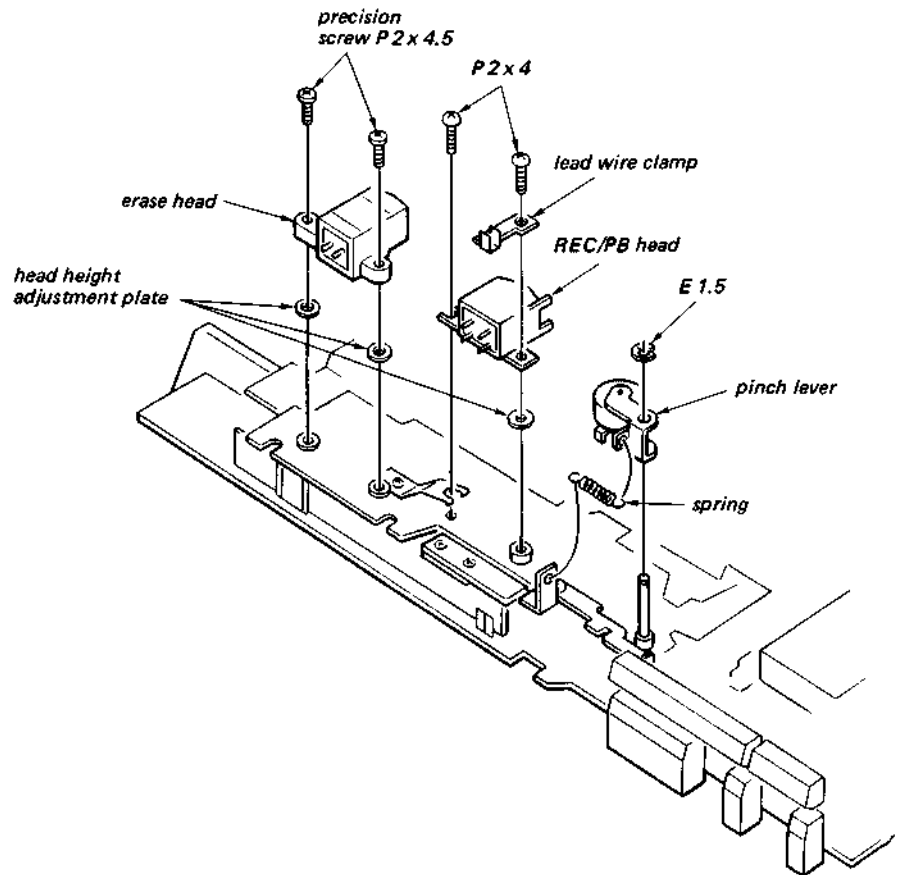

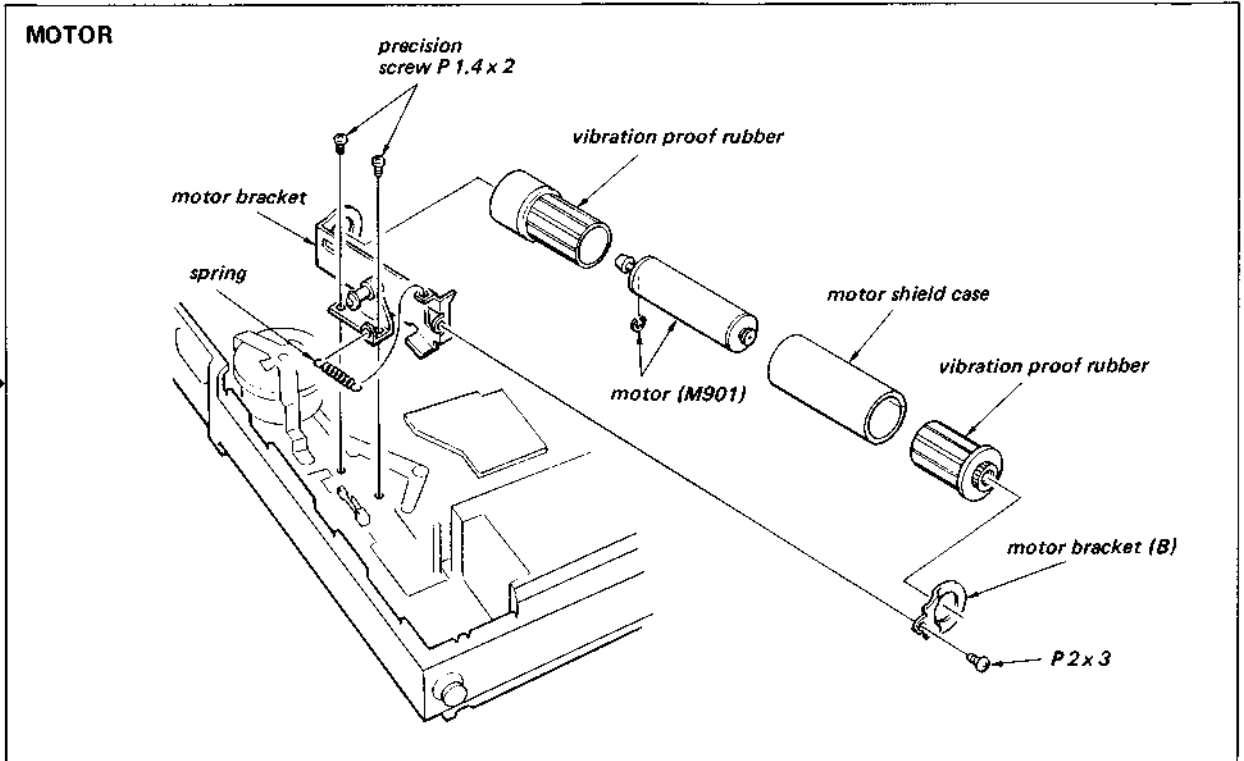

GENERAL NOTES ON SERVICING

Secure the lead wires and shielded wires to the main board with sections of adhesive tapes as shown below, otherwise proper operation of the unit may be degraded.

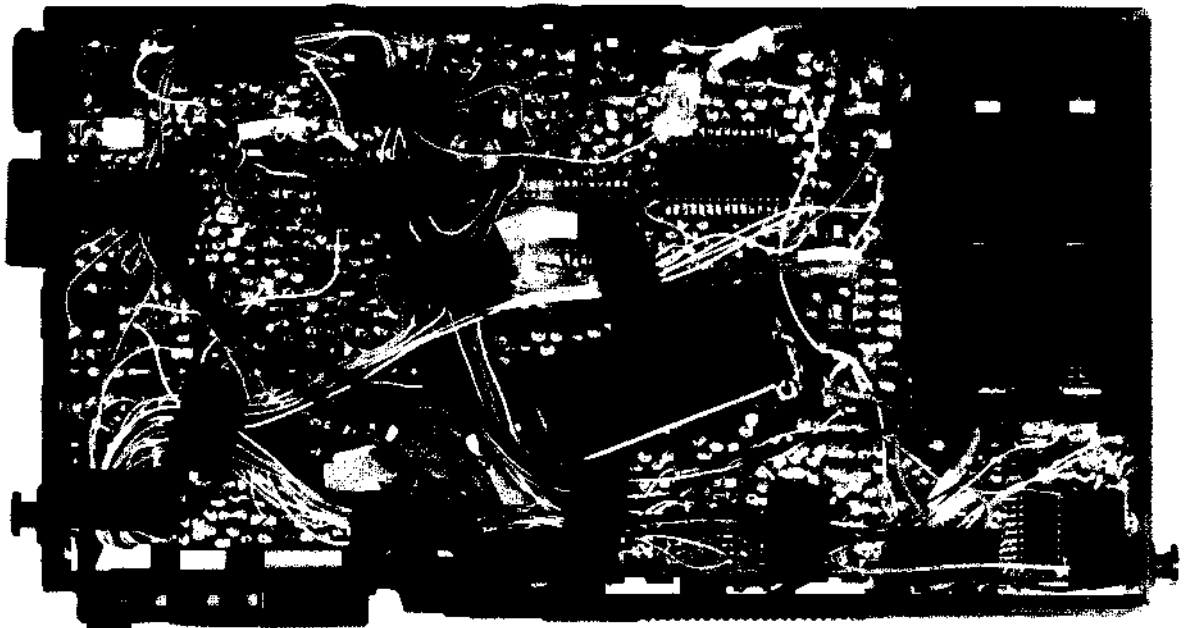

**SECTION 3
ADJUSTMENTS**

3-1. MECHANICAL ADJUSTMENTS AND MEASUREMENTS

PRECAUTION

1. Clean the following parts with a denatured-alcohol-moistened swab:

record/playback head	pinch roller
erase head	rubber belts
capstan	idlers
2. Demagnetize the record/playback and erase head with a head demagnetizer.
3. Do not use a magnetized screwdriver for the adjustments.
4. After the adjustments, apply suitable locking compound to the parts adjusted.
5. The adjustments should be performed with the rated power supply voltage unless otherwise noted.

Pinch Roller Pressure Measurement

— Playback Mode —

② Slowly return the pinch roller and read the spring scale just when the pinch roller starts rotating. (The capstan should first contacts here.)

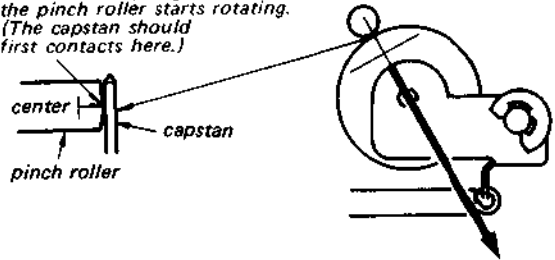

① spring scale
200 – 280 g
(7.05 – 9.88 oz)

Flywheel Thrust Play Adjustment

— Playback Mode —

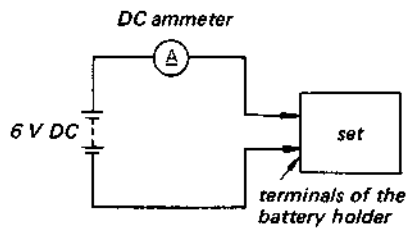

1. Turn the thrust screw counterclockwise until the screw tip leaves from the flywheel shaft.
2. Gradually turn the thrust screw clockwise to the position where the motor current suddenly increases.
3. Then, turn the thrust screw counterclockwise about ¼ turn from the position obtained in step 2.

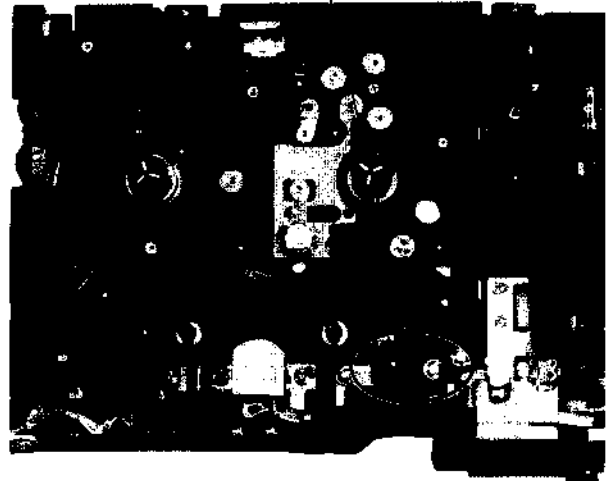

Cassette-holding Spring Adjustment

1. Pull the spring scale outward until the cassette-holding spring releases from the cassette half.
2. Slowly return the spring scale back to the cassette half until the spring just touches the edge of the cassette half. Read the spring scale at this instant.
3. Adjust the spring by bending back and forth to satisfy the spring scale value.

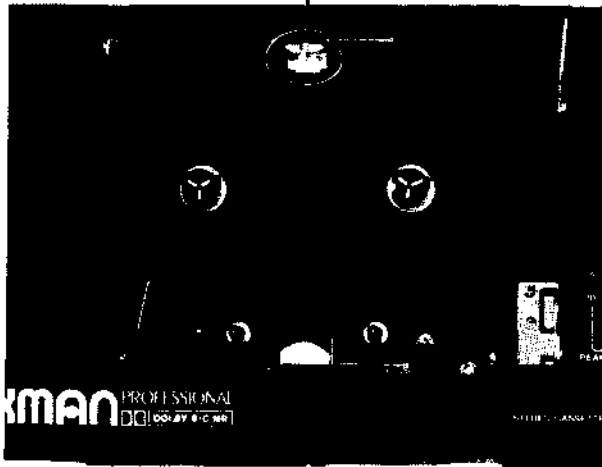
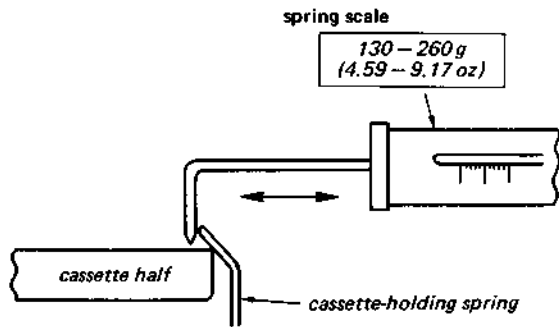

Pause Action Adjustment

1. Insert a cassette tape and put into playback mode.
2. At this time, confirm that the pinch release plate (A) does not touch on the pinch release plate (B) and the pause lever.
3. Check for the lock timing when the pause button is pushed in playback mode.

Lock timing: The tape is stopped without placing in cue mode and is not reversed after the pinch roller is detached from the capstan.

4. When pushing the pause button again to restart the set, make sure that the pinch roller is contact with the capstan after the unit begins to take the tape up without placing in cue mode. Make sure that the take-up reel table does not rotate after the pinch roller is contact with the capstan.

When putting the pause button ON or OFF.	Adjustment of the pinch release plate (A)
In case of CUE mode.	Bend to (A) side.
In case of reversing.	Bend to (B) side.

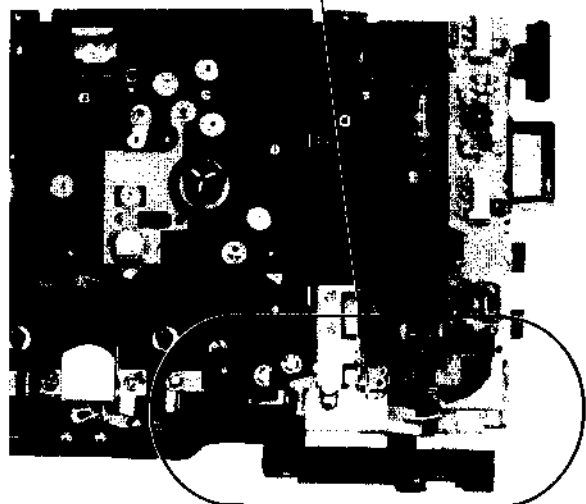
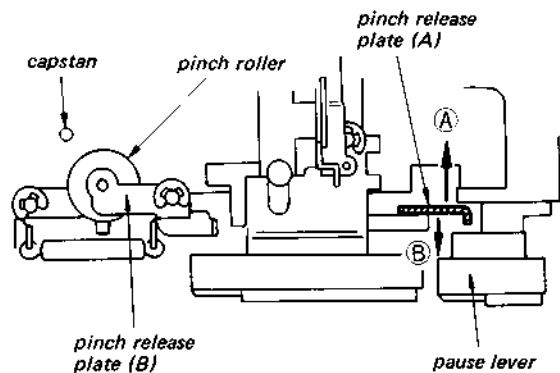

Motor Pressure Measurement

— Playback Mode —

1. The motor pulley's inner edge (large side) should not extend from the edge of the flywheel's rubber ring.

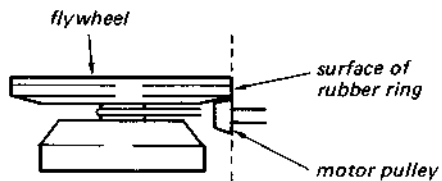

2. When the mode is changed from playback by slowly pressing the stop button, the motor pulley and rubber surface of the flywheel should have clearance.

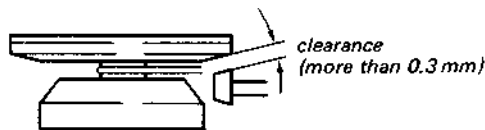

3. In playback mode, put a spring scale vertically on the edge of the motor bracket as shown below, push the spring scale down vertically until the motor pulley just detaches from the flywheel's rubber ring and read the spring scale at this instance.

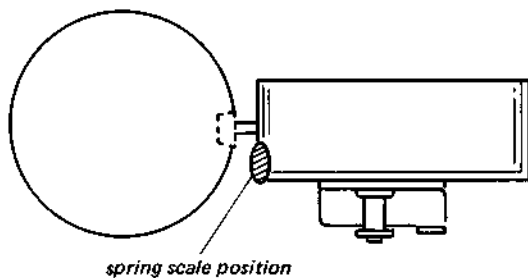
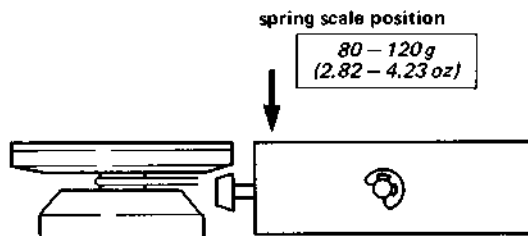

Torque Measurement

Torque	Torque Meter	Meter Reading
FWD	CQ-102C	25 - 43 g·cm (0.35 - 0.6 oz·inch)
Back Tension		1.5 - 3.5 g·cm (0.02 - 0.05 oz·inch)
FF·REW	CQ-201B	more than 75 g·cm (more than 1.04 oz·inch)

Tape Tension Measurement

Tension Meter	Meter Reading
CQ-403A	more than 65 g (more than 2.29 oz)



Tape Path Adjustment

1. Insert a mirror cassette (CQ-009C).
2. In playback mode and viewing from the front, confirm that there is no tape curl and tape twist at portions shown by arrow.
3. If there is tape curl and tape twist, adjust the head heights by using the adjustment plate.
(Specifically no tape curls should exist at the lower sides of the tape guides.)

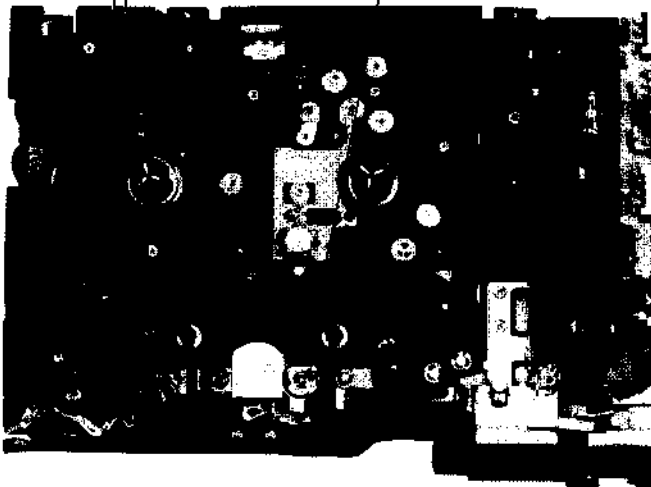
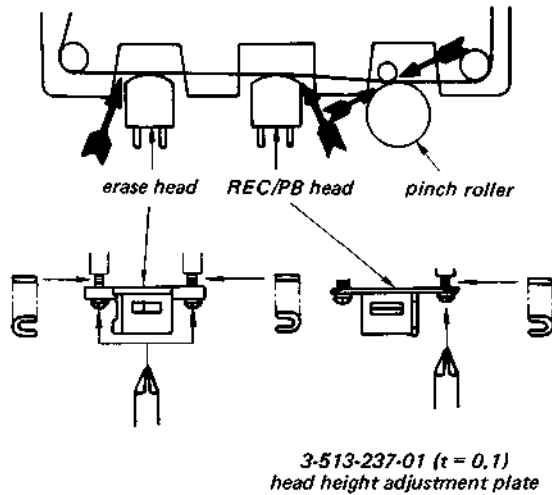

3-2. ELECTRICAL ADJUSTMENTS

Note: The adjustment should be performed in the order given in this service manual. The adjustments should be performed for both L-CH and R-CH.

- Set the TAPE switches according to the tape as follows.

Tape	TAPE switch
CS-15	NORM
CS-26	CrO ₂
CS-40	METAL

- Switches and controls should be set as follows unless otherwise specified.

DOLBY NR switch OFF
 TAPE switch NORM
 MIC ATT switch 0 dB
 PEAK/BATT switch PEAK
 SPEED TUNE switch OFF
 SPEED TUNE control center

- Standard Record:

Deliver the standard input signal level to the input jack and set the REC LEVEL control to obtain the standard output signal level.

Standard Input Level

	MIC	LINE IN
source impedance	300Ω	10kΩ
input level	0.77mV (-60dB)	0.25V (-10dB)

Standard Output Level

	LINE OUT	HEAD- PHONES
load impedance	47kΩ	32Ω
output level	0.254V (-9.8dB)	0.25V (-10dB)

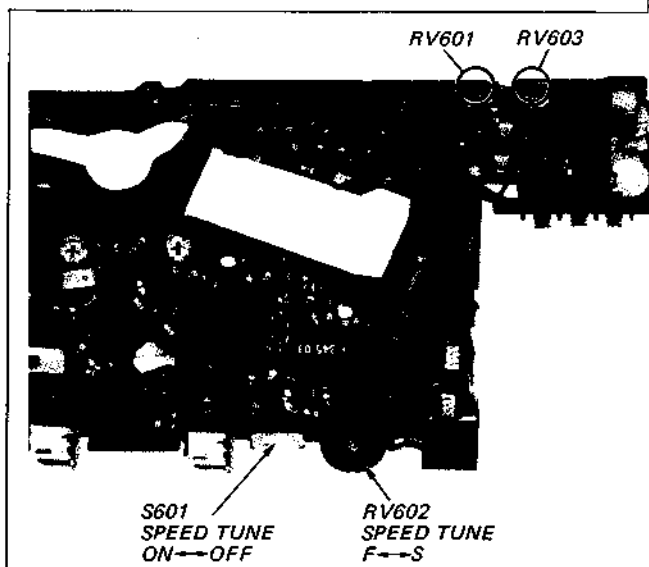

Tape Speed Adjustment

Note: Perform this adjustment after the Record/playback Head Azimuth Adjustment.

Procedure:

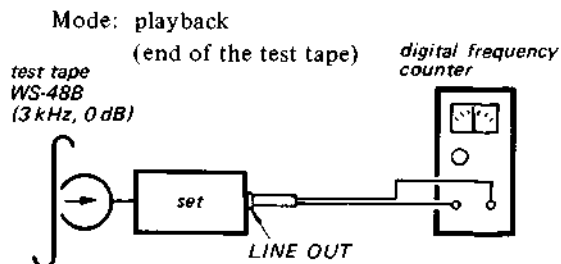

- Set SPEED TUNE switch to OFF.
- Unsolder the solder bridge and open the bridged patterns shown below.
- Turn RV601 so that frequency reading becomes in 3,090 Hz ± 10 Hz.
- Resolder the adjustment patterns opened in step 2 above. Now frequency reading should be 3,000 Hz ± 9 Hz.
- Set SPEED TUNE switch to ON, and SPEED TUNE control to its center position.
- Turn RV603 so that frequency reading becomes in 3,000 Hz ± 10 Hz.
- Set SPEED TUNE control to maximum position in "S" direction. Now frequency reading should be below 2,884 Hz.
- Set SPEED TUNE control to maximum stop in "F" direction. Now the frequency should be above 3,120 Hz.
- Set SPEED TUNE control back to center position.

Adjustment Location: - main board -

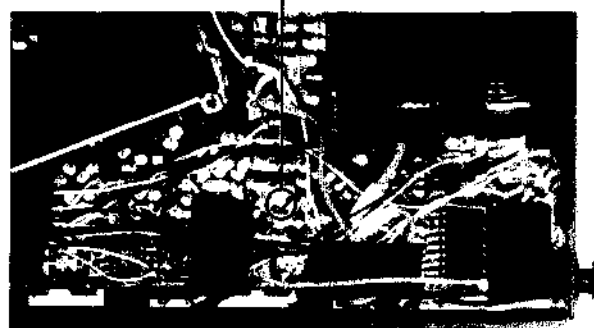
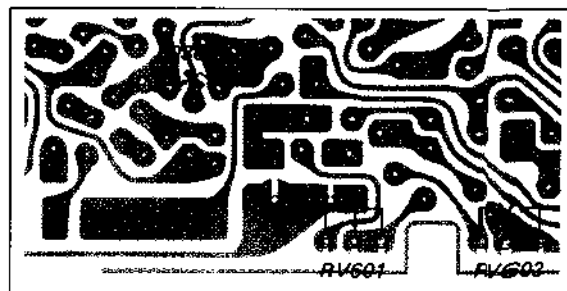

Record/playback Head Azimuth Adjustment

Setting:

RV101, 201 (playback level): mechanical mid

Procedure:

1. Mode: playback

test tape
P-4-A063
(6.3 kHz, -10 dB)

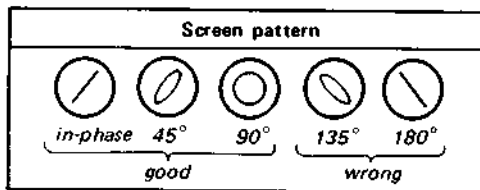
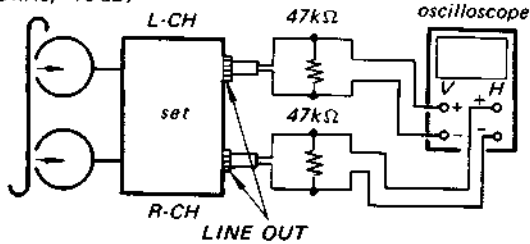

2. Turn the adjustment screw for the maximum output levels. If these levels do not match, turn the adjustment screw until both of output levels match together within 0.5 dB.

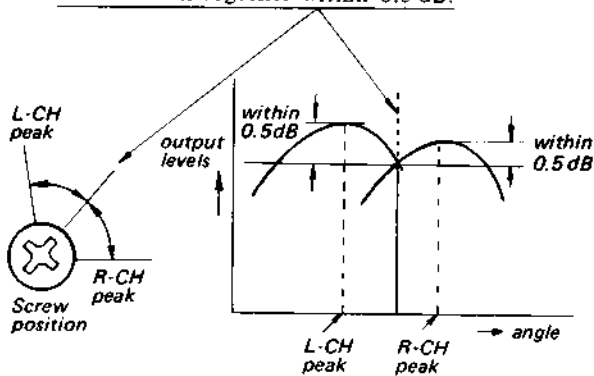

3. After adjustment, apply locking compound to the adjusted screw.

Adjustment Location:



adjustment screw

Playback Level Adjustment

Procedure:

Mode: playback

test tape
P-4-L300
(315 Hz, 0 dB)

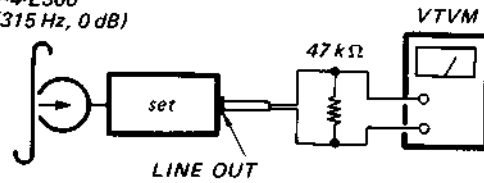

Specification:

LINE OUT level: 0.25 – 0.26 V
(-10 to -9.6 dB)

Check that the LINE OUT level does not change in playback mode while changing the mode from playback to stop several times.

Adjustment Location:

– main board –

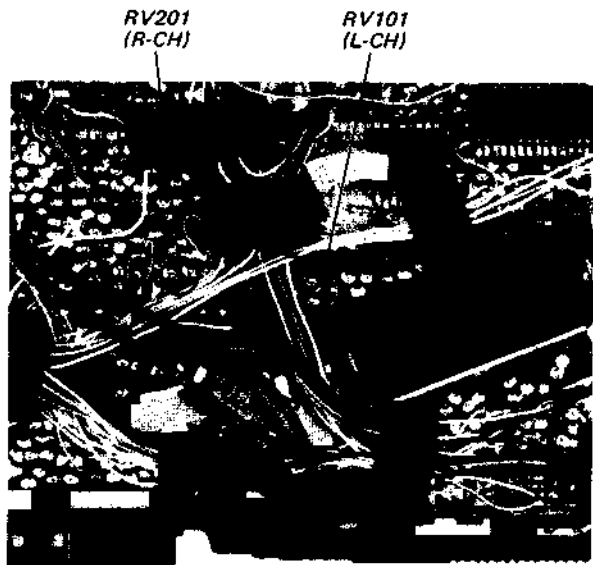

Record Bias Adjustment

Setting:

REC LEVEL control: standard record
 LINE IN : -10 dB
 LINE OUT : -9.8 dB

Procedure:

1. Mode: record

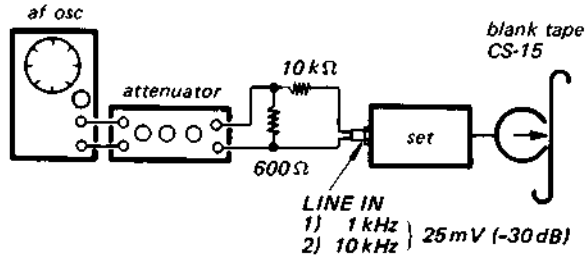

2. Mode: playback

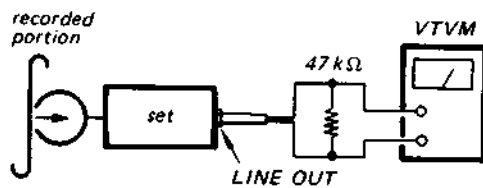

Confirm that the LINE OUT level of 10 kHz signal is 0 ± 0.5 dB relative to that of 1 kHz.

3. If it is not within 0 ± 0.5 dB, change the pattern connection and repeat the steps 1 and 2.

Note: When the conductive patterns ② - ⑥ are connected, and VTVM does not read 0 ± 0.5 dB, disconnect the pattern ①. Repeat the steps 1 - 3.

Adjustment Location:

- main board -

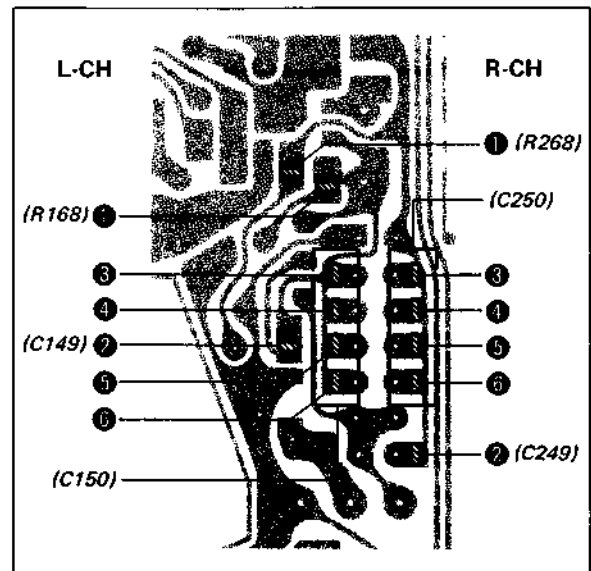

Record Level Adjustment

Setting:

TAPE switch: changes over according

Procedure:

as tape type

1. Mode: record

blank tape
1. CS-15
2. CS-26
3. CS-40

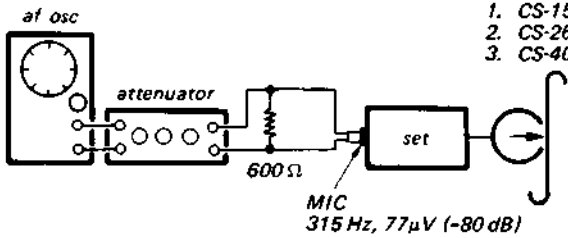

2. Mode: playback

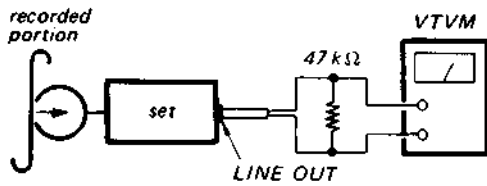

Insert a NORM tape (CS-15) and put into playback mode, adjust RV102 (L-CH) and RV202 (R-CH) to obtain the specified output level. Next, insert a CrO₂ tape (CS-26), METAL tape (CS-40) and put into playback mode, confirm that the output level is specified value.

Specification:

Tape	TAPE switch	Standard Output Level
CS-15	NORM	24 – 26.5 mV (-30.3 to -29.3 dB)
CS-26	CrO ₂	21 – 30 mV (-31.3 to -28.3 dB)
CS-40	METAL	

Adjustment Location:

– main board –

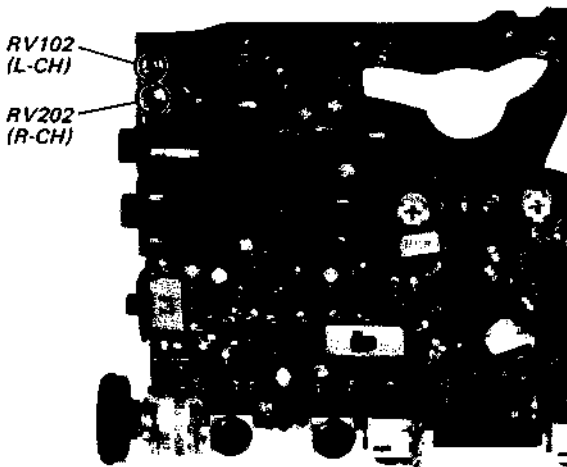

Note: FOR MOUNTING DIAGRAM

- Color code of sleeving over the end of the jacket.

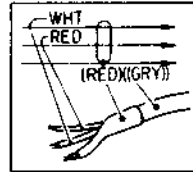

- ○ : parts extracted from the component side.
- ● : parts extracted from the conductor side.
- ■ : part mounted on the conductor side.
- □ : B + pattern
- ———→ : signal path
- - - - - -→ : L-CH signal path
- ·····→ : R-CH signal path

Note: FOR SCHEMATIC DIAGRAM

- Components for right channel have same values as for left channel. Reference numbers are coded from 201.
- All capacitors are in μF unless otherwise noted. pF; μμF 50WV or less are not indicated except for electrolytics and tantalums.
- All resistors are in ohms, 1/6 W unless otherwise noted. kΩ : 1000 Ω, MΩ : 1000 kΩ
- → : signal path
- □ : adjustment for repair.
- ——— : B+ bus.
- Voltages are dc with respect to ground unless otherwise noted.
- Readings are taken under no-signal conditions.

no mark: playback	I: NORM	} TAPE switch
() : record	II: CrO ₂	
[] : rewind	IV: METAL	
< > : fast forward		
⌋ ⌋ : pause		
- Voltage variations may be noted due to normal production tolerances.
- AC voltage readings with a VTVM.
- Total current is measured with no cassette installed.

Note: Voltages are measured with a VOM (50kΩ/V).

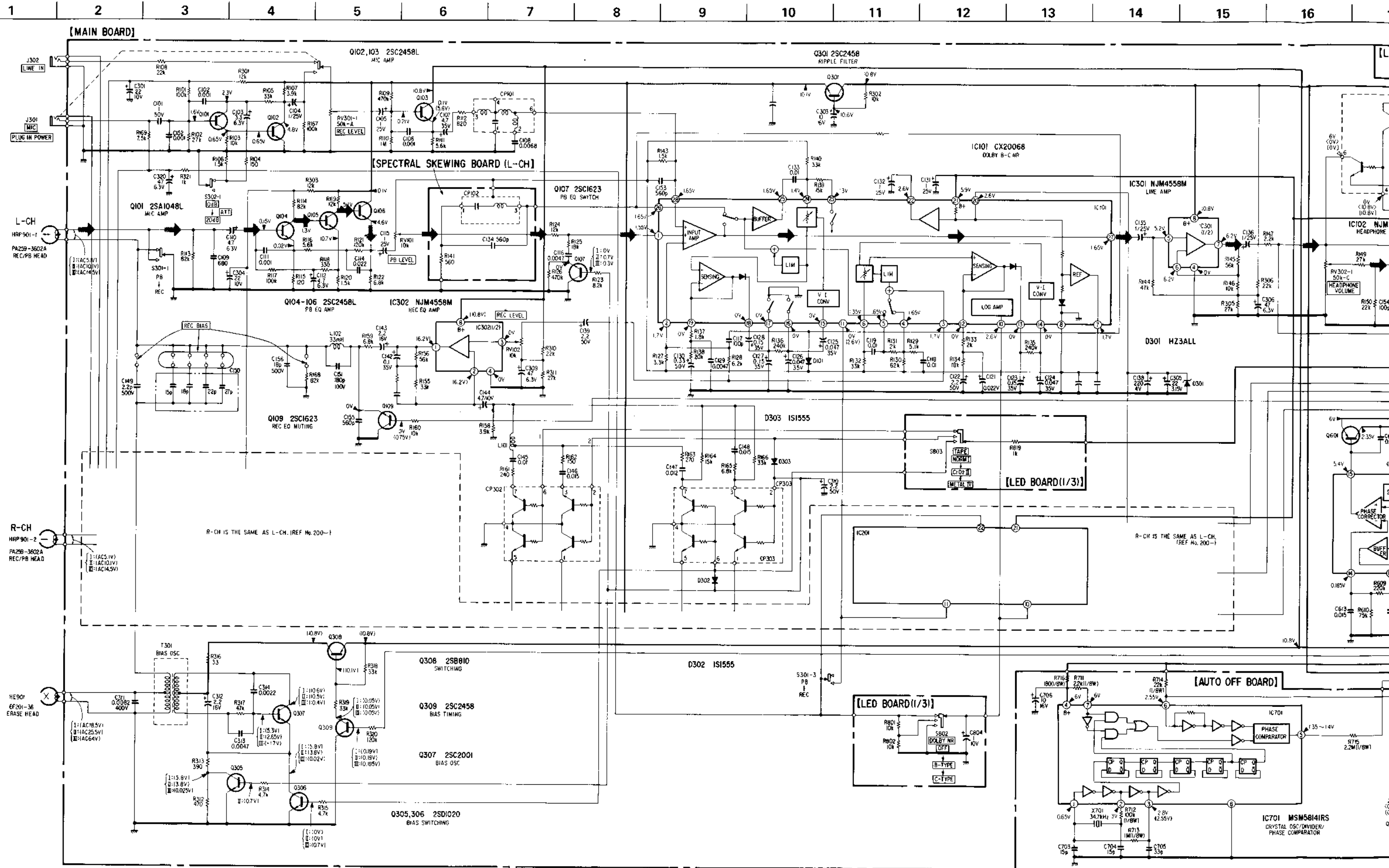

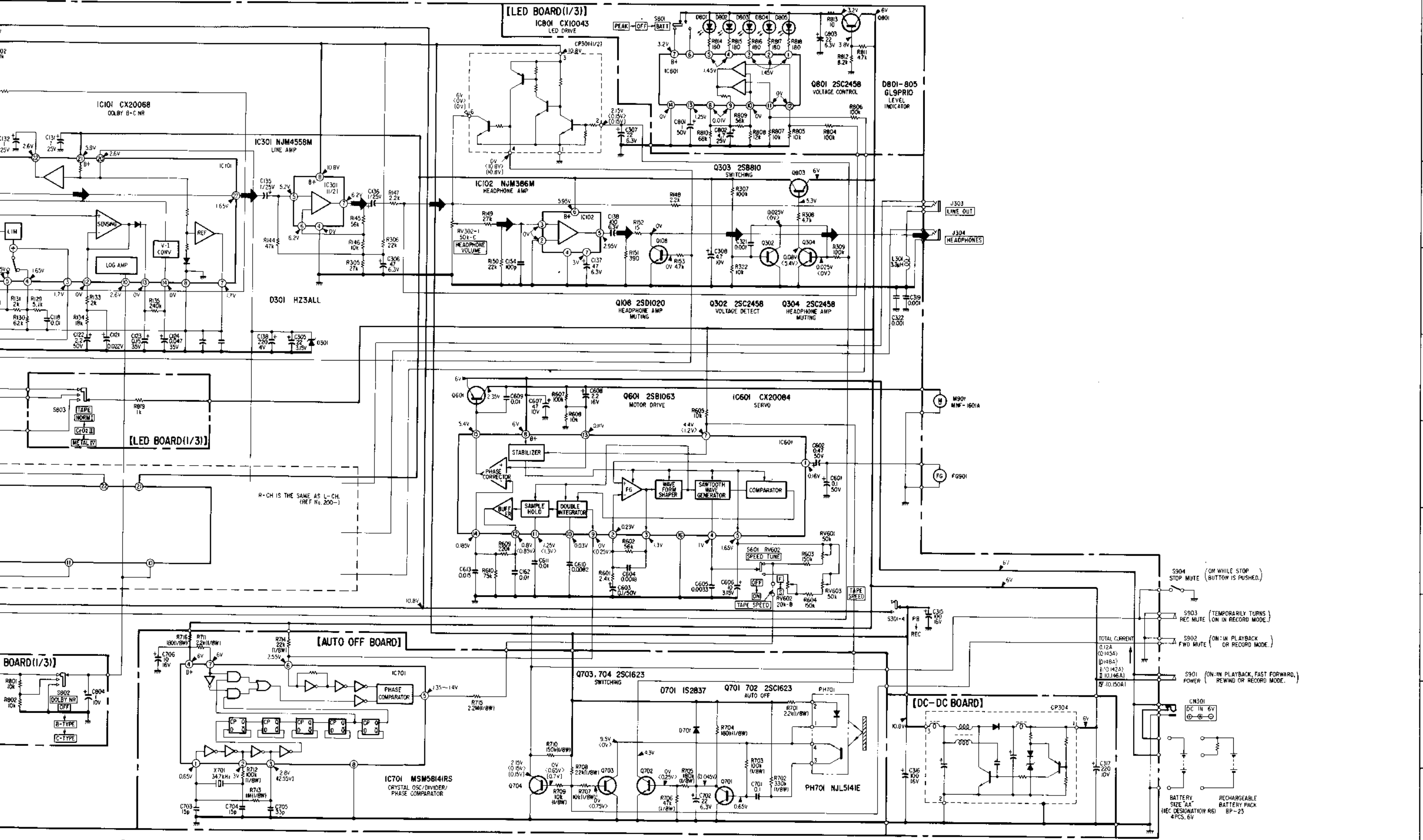

A
B
C
D
E
F
G
H
I
J

Semiconductor Lead Layouts

CX10043
CX20068
CX20084
NJM386M
NJM4558M

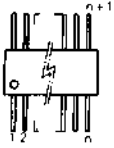

2SD1020



1S1555
HZ3ALL

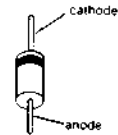

MSM58141RS

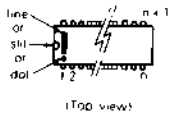

2SA1048-GR
2SB808
2SC2458
2SC2458L-BL



1S2837

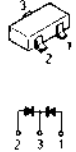

GL9PR10

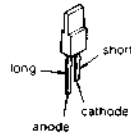

2SB1013
2SC2001



2SC1623

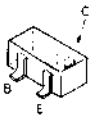

NJL5141E

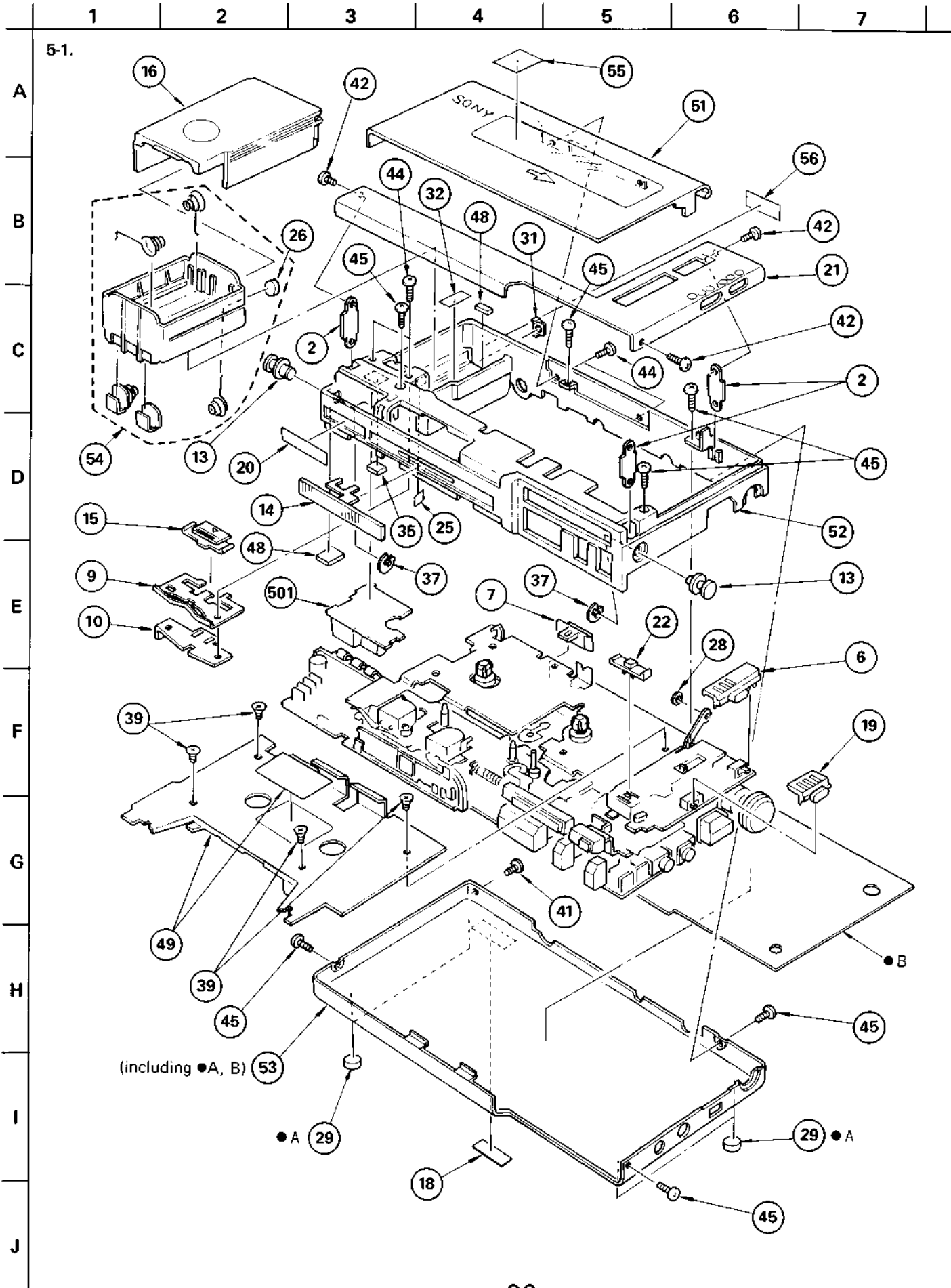
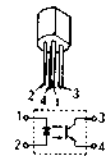

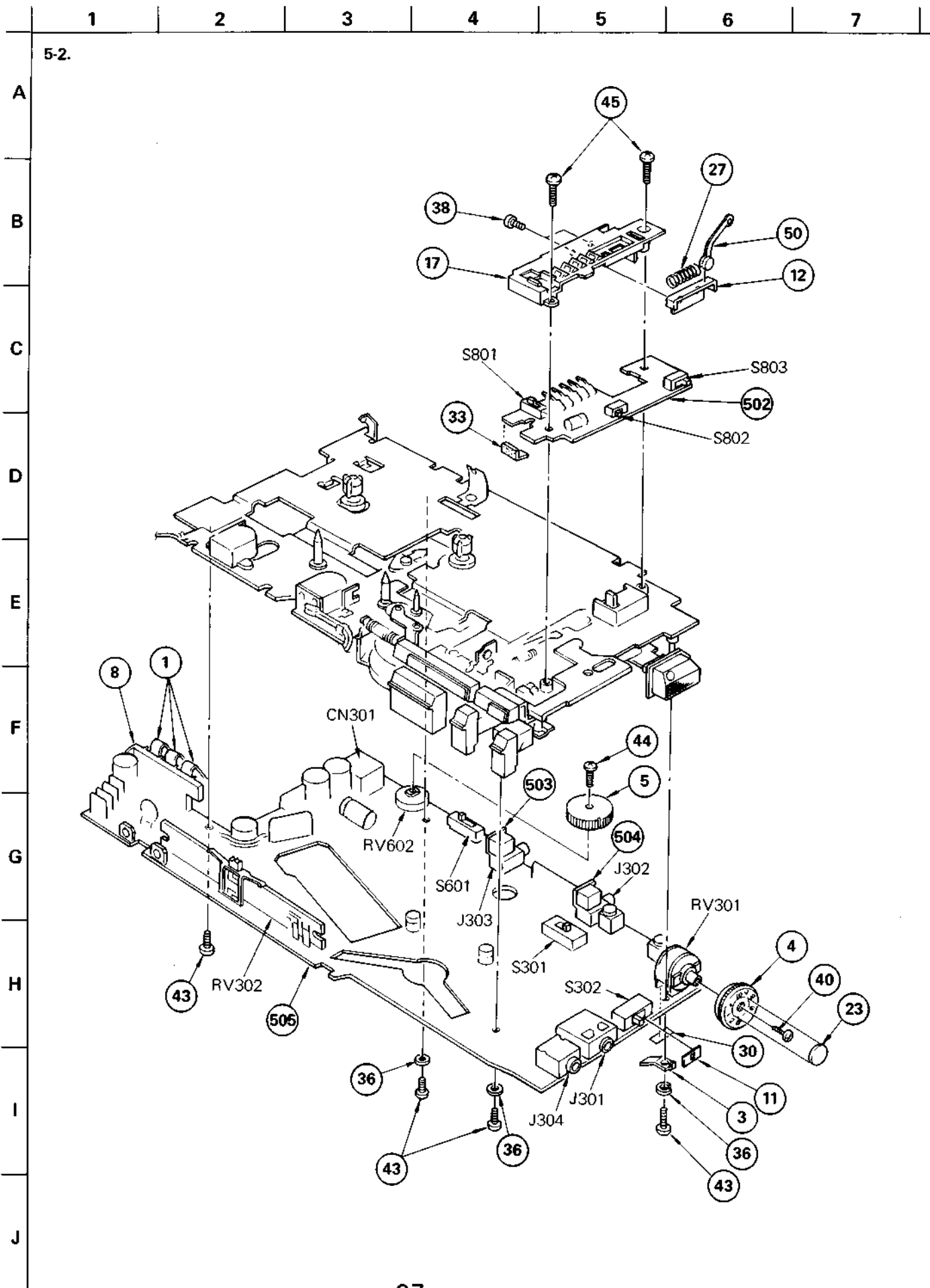

5-2.

A

B

C

D

E

F

G

H

I

J

WM-D6C/TC-D6C

1 2 3 4 5 6 7 8

5-3.

A
B
C
D
E
F
G
H
I
J

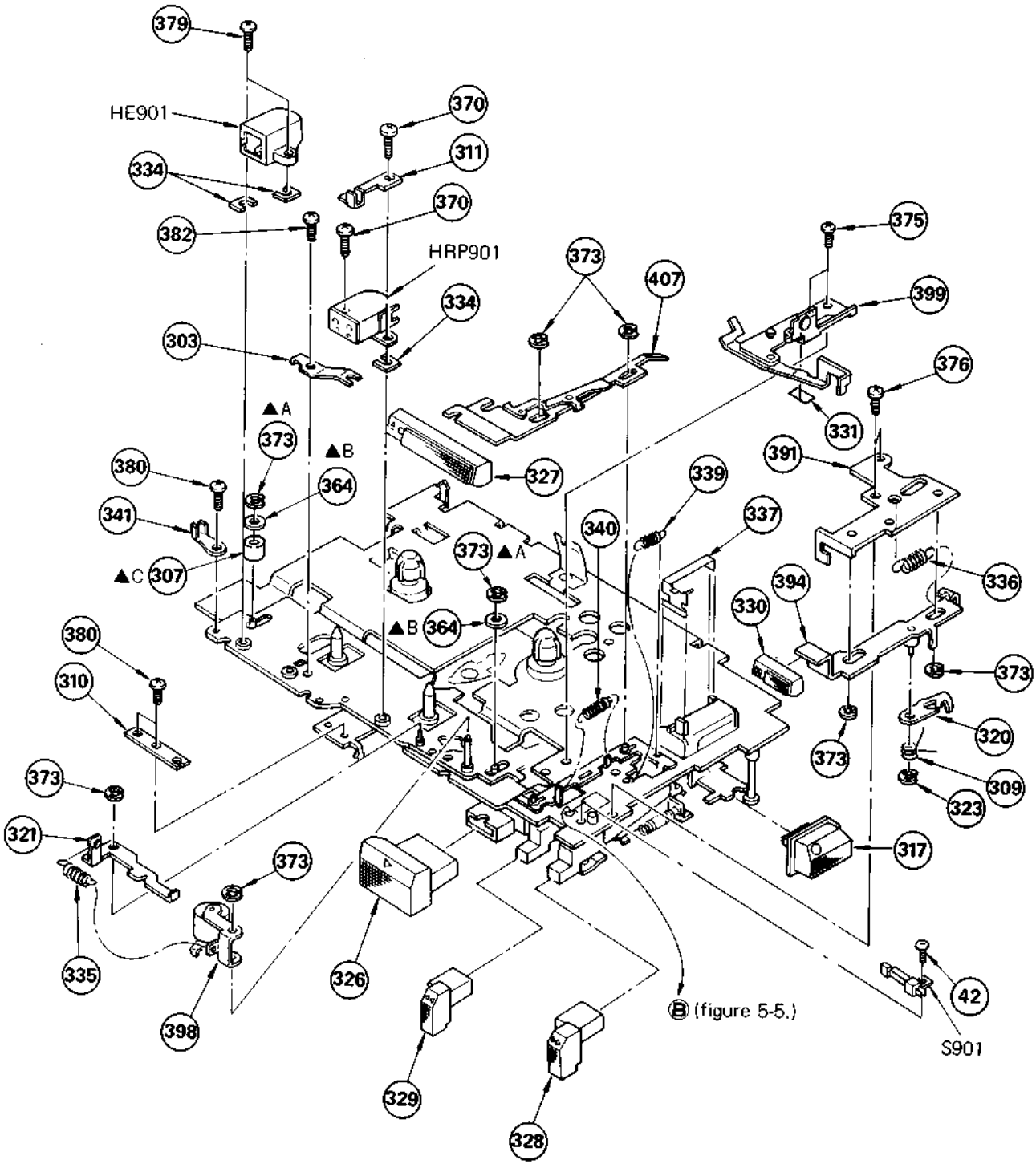

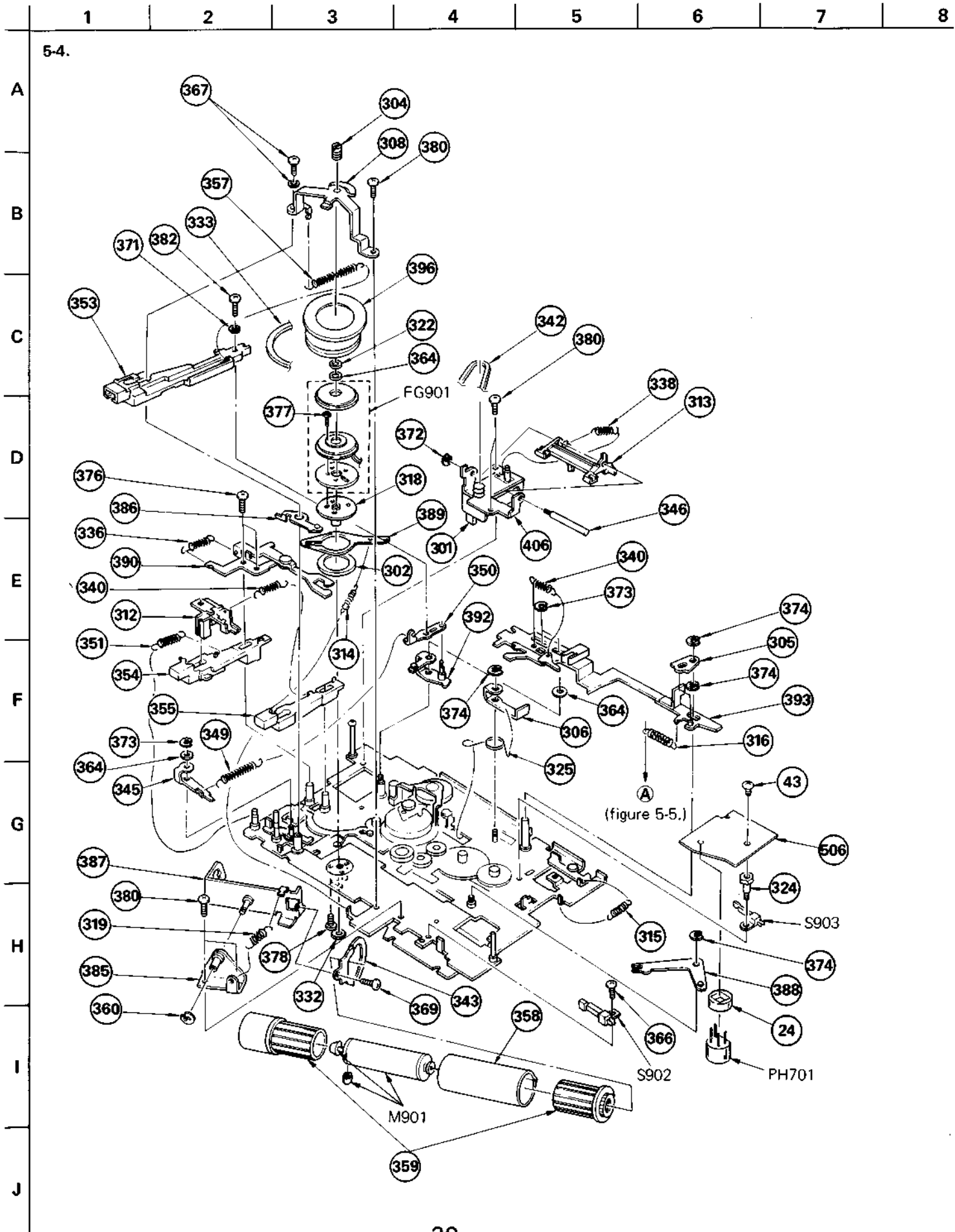

GENERAL SECTION

No.	Part No.	Description
1	3-305-801-00	SPRING
2	3-305-802-00	PLATE, NUT
3	3-305-804-00	SPRING
4	3-305-867-00	KNOB (A), CONTROL, REC
5	3-305-868-00	KNOB, SPEED CONTROL
6	3-305-871-11	KNOB, TAPE SELECTOR
7	3-305-872-00	KNOB, SWITCH, SPEED CONTROL
8	3-305-873-00	TERMINAL BOARD, BATTERY
9	3-305-874-00	SPRING
10	♣;3-305-875-00	CHASSIS, CLAW, LOCK
11	3-305-887-00	COVER, SWITCH
12	♣;3-305-888-00	RETAINER
13	3-305-889-00	SHAFT, BELT, CARRYING
14	3-305-891-00	KNOB, CONTROL, SLIDE
15	3-305-892-00	CLAW, LOCK
16	3-305-896-00	CASE, BATTERY
17	3-305-897-00	HOLDER, LED
18	3-305-947-00	LABEL, DOLBY
19	3-305-961-01	KNOB, DOLBY
20	3-305-962-01	LABEL, FRONT
21	3-305-963-01	(WM-D6C)...PANEL, UPPER
21	3-305-969-01	(TC-D6C)...PANEL, UPPER
22	3-305-966-01	KNOB, METER
23	3-305-967-01	PLATE, ORNAMENTAL
24	♣;3-308-430-00	RETAINER, REFLECTOR, PHOTO
25	9-910-840-XX	CUSHION, RELEASE (t=3)
26	3-527-126-00	MARK, BATTERY CASE
27	3-557-575-00	SPRING, COMPRESSION
28	3-570-615-00	POLY-WASHER (DIA.1.2)
29	3-570-903-00	LEG
30	♣;3-572-862-00	SPACER
31	3-574-744-00	PLATE (B), NUT
32	3-701-999-00	LABEL, SERIAL NUMBER
33	3-831-441-XX	SPACER (t=0.5)
34	3-831-441-XX	CUSHION (t=0.5)
35	3-884-171-00	STOPPER
36	7-623-203-11	SW 1.4,TYPE 1
37	7-624-106-04	STOP RING 3.0, TYPE -E
38	7-627-451-38	SCREW, PRECISION +K 1.4X2
39	7-627-551-08	SCREW, PRECISION +P 1.4X1.6
40	7-627-552-37	SCREW, PRECISION +P 1.7X3
41	7-627-850-08	SCREW, PRECISION +P 1.4X2
42	7-627-850-18	SCREW, PRECISION +P 1.4X2.5
43	7-627-850-27	SCREW, PRECISION +P 1.4X3
44	7-627-850-28	SCREW, PRECISION +P 1.4X3
45	7-627-850-58	SCREW, PRECISION +P 1.4X3.5

NOTE:

- The mechanical parts with no reference number in the exploded views are not supplied.
- Items marked "♣" are not stocked since they are seldom required for routine service. Some delay should be anticipated when ordering these items.
- Due to standardization, parts with part numbers (Δ-ΔΔΔ-ΔΔΔ-XX or Δ-ΔΔΔΔ-ΔΔΔ-X) may be different from those used in the set.
- If there are two or more same circuits in a set such as a stereophonic machine, only typical circuit parts may be indicated and capacitors and resistors in other same circuits may be omitted.

CAPACITORS:

- All capacitors are in μF. Common capacitors are omitted. Refer to the following lists for their part numbers.
MF:μF, PF:μμF.

COILS

- MMH : mH, UH : μH

SEMICONDUCTORS

- In each case, U : u, for example:
UA...: μA..., UPA...: μPA..., UPC...: μPC,
UPD...: μPD...

GENERAL SECTION

No.	Part No.	Description
46	9-911-837-XX	SPACER (t=1)
47	9-911-841-XX	CUSHION (B)(t=5)
48	9-911-845-XX	CUSHION (A)(t=5)
49	A-3043-068-A	PANEL SUB ASSY, REEL
50	X-3305-801-0	ARM ASSY
51	X-3305-818-0	LID ASSY, CASSETTE
52	X-3305-834-1	CABINET ASSY
53	X-3305-835-1	PANEL ASSY, LOWER
54	X-3564-820-0	HOLDER ASSY, BATTERY
55	3-703-707-01	STICKER, SONY SYMBOL (21)
56	3-305-968-01	(TC-D6C)...LABEL, MODEL NUMBER

ACCESSORY & PACKING MATERIAL

Part No. Description

1-555-658-00	CORD, CONNECTION (RK-129)
3-305-935-00	(WM-D6C)...SPACER
3-305-972-00	(TC-D6C)...SPACER
3-305-973-00	(TC-D6C)...INDIVIDUAL CARTON
3-305-981-00	(WM-D6C)...INDIVIDUAL CARTON
3-305-975-00	(TC-D6C)...CUSHION
3-305-938-00	(WM-D6C)...CUSHION
3-305-980-00	(WM-D6C)...COVER, ACCESSORY
3-305-940-00	BAND, SHOULDER
3-305-970-00	CASE, CARRYING
3-570-631-71	BAG, POLYETHYLENE, FOR SET
3-701-618-00	BAG, POLYETHYLENE, FOR CONNECTION CORD
3-701-625-00	BAG, POLYETHYLENE, FOR INSTRUCTION MANUAL
3-773-736-11	(AEP)...MANUAL, INSTRUCTION
3-773-736-21	(US)...MANUAL, INSTRUCTION
3-773-736-31	(Canadian,AEP,UK,E)...MANUAL, INSTRUCTION
3-773-766-21	(TC-D6C)...MANUAL, INSTRUCTION
3-795-748-21	(US)...SAFETY INSTRUCTIONS, HEADPHONE
8-810-036-90	(TC-D6C)...ECM-939LT SET
8-951-173-90	(WM-D6C)...MDR-40L SET

The components identified by shading and mark  are critical for safety. Replace only with part number specified.

Les composants identifiés par une trame et une marque  sont critiques pour la sécurité. Ne les remplacer que par une pièce portant le numéro spécifié.

WM-D6C/TC-D6C

MECHANISM SECTION

No.	Part No.	Description
301	1-548-516-41	TIMER, TAPE
302	♣;3-305-807-00	RING, MOTOR LEVER
303	3-305-808-00	SPRING
304	3-305-810-00	SCREW, THRUST ADJUSTMENT
305	3-305-812-00	LEVER (C), REC
306	♣;3-305-815-00	LEVER (A), MUTING
307	3-305-839-00	ROLLER (SMALL)
308	3-305-846-00	RETAINER, THRUST
309	3-305-856-00	SPRING
310	♣;3-305-857-00	RETAINER, FG LEAD WIRE
311	3-305-858-00	CLAMP, LEAD WIRE
312	3-305-863-00	HOLDER, LEAD WIRE
313	3-305-865-00	PLATE, LOCK
314	3-305-901-00	SPRING, TENSION
315	3-305-902-00	SPRING, TENSION
316	3-305-903-00	SPRING, TENSION
317	3-305-908-00	BUTTON, REC
318	3-305-910-00	BEARING (A), CAPSTAN
319	3-305-914-00	SPRING, TENSION
320	3-305-915-00	PLATE, LOCK, PAUSE
321	3-305-917-00	PLATE (B), RELEASE, PINCH
322	3-305-925-00	WASHER
323	3-305-926-00	POLY-WASHER, 1.7DIA
324	3-305-952-01	SCREW, SWITCH
325	3-305-953-01	SPRING
326	3-305-956-01	BUTTON, FWD
327	3-305-957-01	BUTTON, STOP
328	3-305-958-01	BUTTON, FF
329	3-305-959-01	BUTTON, REW
330	3-305-960-01	BUTTON, PAUSE
331	♣;3-309-729-00	SHEET, LEAF SWITCH
332	3-314-576-00	WASHER
333	3-480-136-00	BELT (B)
334	3-513-237-01	PLATE
335	3-527-189-00	SPRING, TENSION
336	3-527-190-00	SPRING, TENSION
337	♣;3-305-971-01	TERMINAL PLATE
338	3-547-666-00	SPRING, TENSION
339	3-547-667-00	SPRING, TENSION
340	3-547-669-00	SPRING, TENSION
341	♣;3-547-686-00	CLAMP (B), WIRE
342	3-554-103-00	BELT, DRIVING
343	♣;3-556-269-00	BRACKET (B), M
344	3-557-402-00	LEVER (C), RELEASE
345	3-557-405-00	LEVER, SPRING HOOK

NOTE:

- The mechanical parts with no reference number in the exploded views are not supplied.
- Items marked "♣" are not stocked since they are seldom required for routine service. Some delay should be anticipated when ordering these items.
- Due to standardization, parts with part numbers (Δ-ΔΔΔ-ΔΔΔ-XX or Δ-ΔΔΔΔ-ΔΔΔ-X) may be different from those used in the set.
- If there are two or more same circuits in a set such as a stereophonic machine, only typical circuit parts may be indicated and capacitors and resistors in other same circuits may be omitted.

MECHANISM SECTION

No.	Part No.	Description
346	3-557-408-00	SHAFT, LOCK PLATE
347	3-557-439-00	GEAR (A), F.R
348	3-557-440-00	GEAR (B), F.R
349	3-557-495-00	SPRING, TENSION
350	3-557-497-00	ARM, JOINT
351	3-557-498-00	SPRING, TENSION
352	3-557-509-00	GEAR (3)
353	3-557-514-00	LEVER, FWD
354	3-557-515-00	LEVER, FF
355	3-557-516-00	LEVER, REWIND
356	3-557-579-00	SPRING, TENSION
357	3-557-581-00	SPRING, TENSION
358	♣;3-557-805-00	CASE, SHIELD, M
359	♣;3-557-813-00	RUBBER, VIBRATION PROOF
360	3-558-708-21	WASHER, STOPPER
361	3-559-408-00	POLY-WASHER, 1.2 DIA
362	3-570-894-00	SPRING, TENSION
363	3-701-436-01	WASHER, 1.6 (t=0.13)
364	3-701-437-01	WASHER, 2 (t=0.13)
365	
366	3-703-502-22	SCREW
367	3-703-502-32	SCREW
368	3-831-441-XX	SPACER (t=0.5)
369	7-621-255-15	SCREW +P 2X3
370	7-621-255-25	SCREW +P 2X4
371	7-623-203-11	SW 1.4, TYPE 1
372	7-624-101-01	RING, RETAINING E-1.2
373	7-624-102-04	STOP RING 1.5, TYPE -E
374	7-624-104-04	STOP RING 2.0, TYPE -E
375	7-627-451-08	SCREW, PRECISION +K 1.4X1.6
376	7-627-451-27	SCREW, PRECISION +K 1.4X3
377	7-627-551-57	SCREW, PRECISION +P 1.4X2
378	7-627-551-78	SCREW, PRECISION +P 1.4X4
379	7-627-553-57	SCREW, PRECISION +P 2X4.5
380	7-627-850-07	SCREW, PRECISION +P 1.4X2
381	7-627-850-47	SCREW, PRECISION +P 1.4X1.6
382	7-627-851-27	SCREW, PRECISION +P 1.4X5
383	7-671-111-01	STEEL BALL IMM
384	X-3305-804-0	PULLEY ASSY, MIDWAY
385	♣;X-3305-806-0	BRACKET ASSY, MOTOR SHAFT
386	X-3305-807-0	LEVER (A) ASSY, MOTOR
387	♣;X-3305-808-0	BRACKET ASSY, MOTOR
388	X-3305-809-0	LEVER (C) ASSY, MOTOR
389	X-3305-810-0	LEVER (B) ASSY, MOTOR
390	X-3305-811-0	CHASSIS ASSY, SO

CAPACITORS:

- All capacitors are in μF . Common capacitors are omitted. Refer to the following lists for their part numbers.
MF: μF , PF: $\mu\mu\text{F}$.

COILS

- MMH : mH, UH : μH

SEMICONDUCTORS

- In each case, U : μ , for example:
UA.... : μA, UPA.... : μPA, UPC.... : μPC ,
UPD.... : μPD

MECHANISM SECTION

No.	Part No.	Description
391	X-3305-812-0	CHASSIS ASSY, PAUSE
392	X-3305-813-0	LEVER (B) ASSY, REC
393	X-3305-814-0	LEVER (A) ASSY, REC
394	X-3305-821-0	LEVER ASSY, PAUSE
395	♣;X-3305-823-0	CHASSIS ASSY, HEAD
396	X-3305-824-0	FLYWHEEL BLOCK ASSY
397	♣;X-3305-826-0	LEVER ASSY, PREVENTION, SO
398	X-3305-827-0	PINCH LEVER ASSY
399	X-3305-828-0	TABLE ASSY, EJECT LEVER
400	X-3305-832-1	TABLE COMPLETE ASSY, BEARING
401	♣;X-3305-833-1	CHASSIS ASSY, MECHANICAL
402	X-3557-407-0	IDLER ASSY, FWD
403	♣;X-3557-408-0	LEVER (B) ASSY, F.R
404	X-3557-409-0	PULLEY ASSY, F.R
405	X-3557-411-0	LEVER (A) ASSY, F.R
406	X-3557-433-0	BRACKET ASSY, COUNTER
407	X-3568-702-0	LEVER ASSY, STOP

ELECTRICAL PARTS

Ref.No.	Part No.	Description				
501	♣;1-611-493-11	PC BOARD, DC-DC				
502	♣;1-611-495-11	PC BOARD, LED				
503	♣;1-611-909-11	PC BOARD, SPECTRAL SKEWING (R)				
504	♣;1-611-910-11	PC BOARD, SPECTRAL SKEWING (L)				
505	♣;A-3068-070-A	MOUNTED PCB, MAIN				
506	♣;A-3068-074-A	MOUNTED PCB, AUTO-OFF				
C101	1-124-499-00	ELECT	1MF	20%	50V	
C102	1-102-074-00	CERAMIC	0.001MF	10%	50V	
C103	1-131-386-00	TANTALUM	33MF	20%	6.3V	
C104	1-131-408-00	TANTALUM	1MF	20%	35V	
C105	1-131-408-00	TANTALUM	1MF	20%	35V	
C106	1-102-074-00	CERAMIC	0.001MF	10%	50V	
C107	1-123-615-00	ELECT	4.7MF	20%	35V	
C108	1-161-011-00	CERAMIC	0.0068MF	10%	25V	
C109	1-102-116-00	CERAMIC	680PF	10%	50V	
C110	1-131-375-00	TANTALUM	4.7MF	20%	10V	
C111	1-102-074-00	CERAMIC	0.001MF	10%	50V	
C112	1-131-375-00	TANTALUM	4.7MF	20%	10V	
C113	1-102-115-00	CERAMIC	560PF	10%	50V	
C114	1-130-487-00	MYLAR	0.022MF	5%	50V	
C115	1-131-408-00	TANTALUM	1MF	20%	35V	
C116	1-130-479-00	MYLAR	0.0047MF	5%	50V	
C117	1-102-106-00	CERAMIC	100PF	10%	50V	
C118	1-130-483-00	MYLAR	0.01MF	5%	50V	

NOTE:

- The mechanical parts with no reference number in the exploded views are not supplied.
- Items marked "♣" are not stocked since they are seldom required for routine service. Some delay should be anticipated when ordering these items.
- Due to standardization, parts with part numbers (Δ-ΔΔΔ-ΔΔΔ-XX or Δ-ΔΔΔΔ-ΔΔΔ-XX) may be different from those used in the set.
- If there are two or more same circuits in a set such as a stereophonic machine, only typical circuit parts may be indicated and capacitors and resistors in other same circuits may be omitted.

ELECTRICAL PARTS

Ref.No.	Part No.	Description				
C119	1-130-483-00	MYLAR	0.01MF	5%	50V	
C120	1-131-389-00	TANTALUM	10MF	20%	3.15V	
C121	1-161-017-00	CERAMIC	0.022MF	10%	25V	
C122	1-124-257-00	ELECT	2.2MF	20%	50V	
C123	1-131-342-00	TANTALUM	0.15MF	10%	35V	
C124	1-131-400-00	TANTALUM	0.047MF	20%	35V	
C125	1-131-400-00	TANTALUM	0.047MF	20%	35V	
C126	1-131-400-00	TANTALUM	0.047MF	20%	35V	
C127	1-131-342-00	TANTALUM	0.15MF	10%	35V	
C128	1-131-342-00	TANTALUM	0.15MF	10%	35V	
C129	1-161-009-00	CERAMIC	0.0047MF	10%	25V	
C130	1-124-252-00	ELECT	0.33MF	20%	50V	
C131	1-131-408-00	TANTALUM	1MF	20%	35V	
C132	1-131-408-00	TANTALUM	1MF	20%	35V	
C133	1-130-483-00	MYLAR	0.01MF	5%	50V	
C134	1-102-115-00	CERAMIC	560PF	10%	50V	
C135	1-131-408-00	TANTALUM	1MF	20%	35V	
C136	1-131-408-00	TANTALUM	1MF	20%	35V	
C137	1-124-224-00	ELECT	47MF	20%	6.3V	
C138	1-123-661-00	ELECT	100MF	20%	6.3V	
C139	1-124-257-00	ELECT	2.2MF	20%	50V	
C141	1-102-116-00	CERAMIC	680PF	10%	50V	
C142	1-131-341-00	TANTALUM	0.1MF	20%	35V	
C143	1-131-361-00	TANTALUM	2.2MF	20%	20V	
C144	1-131-375-00	TANTALUM	4.7MF	20%	10V	
C145	1-130-483-00	MYLAR	0.01MF	5%	50V	
C146	1-130-485-00	MYLAR	0.015MF	5%	50V	
C147	1-130-484-00	MYLAR	0.012MF	5%	50V	
C148	1-130-485-00	MYLAR	0.015MF	5%	50V	
C149	1-107-042-00	MICA	2.2PF		500V	
C150	1-107-323-00	MICA CAPACITOR UNIT				
C151	1-163-988-00	CERAMIC CHIP	180PF	5%	100V	
C152	1-102-074-00	CERAMIC	0.001MF	10%	50V	
C153	1-102-115-00	CERAMIC	560PF	10%	50V	
C154	1-163-181-00	CERAMIC CHIP	100PF	5%	50V	
C155	1-102-115-00	CERAMIC	560PF	10%	50V	
C156	1-107-208-00	MICA	18PF	5%	500V	
C301	1-124-228-00	ELECT	22MF	20%	10V	
C302	1-131-371-00	TANTALUM	10MF	20%	16V	
C303	1-123-617-00	ELECT	10MF	20%	16V	
C304	1-124-228-00	ELECT	22MF	20%	10V	
C305	1-131-391-00	TANTALUM	22MF	20%	3.15V	
C306	1-124-224-00	ELECT	47MF	20%	6.3V	
C307	1-123-618-00	ELECT	22MF	20%	6.3V	
C308	1-131-375-00	TANTALUM	4.7MF	20%	10V	

CAPACITORS:

- All capacitors are in μF. Common capacitors are omitted. Refer to the following lists for their part numbers.
- MF:μF, PF:μμF.

COILS

- MMH : mH, μH : μH

SEMICONDUCTORS

- In each case, U : μ, for example:
- UA.... : μA...., UPA.... : μPA...., UPC.... : μPC,
- UPD.... : μPD....

ELECTRICAL PARTS

Ref.No.	Part No.	Description			
C309	1-124-224-00	ELECT	47MF	20%	6.3V
C310	1-123-612-00	ELECT	2.2MF	20%	50V
C311	1-130-896-00	FILM	0.0082MF	5%	400V
C312	1-131-361-00	TANTALUM	2.2MF	20%	20V
C313	1-130-479-00	MYLAR	0.0047MF	5%	50V
C314	1-161-005-00	CERAMIC	0.0022MF	10%	25V
C315	1-123-320-00	ELECT	100MF	20%	16V
C316	1-123-320-00	ELECT	100MF	20%	16V
C317	1-123-308-00	ELECT	220MF	20%	10V
C318	1-123-827-00	ELECT	220MF	20%	4V
C319	1-102-074-00	CERAMIC	0.001MF	10%	50V
C320	1-124-224-00	ELECT	47MF	20%	6.3V
C321	1-102-074-00	CERAMIC	0.001MF	10%	50V
C322	1-102-074-00	CERAMIC	0.001MF	10%	50V
C601	1-123-607-00	ELECT	0.1MF	20%	50V
C602	1-123-610-00	ELECT	0.47MF	20%	50V
C603	1-123-607-00	ELECT	0.1MF	20%	50V
C604	1-102-120-00	CERAMIC	0.0018MF	10%	50V
C605	1-130-865-00	FILM	0.0033MF	5%	50V
C606	1-131-389-00	TANTALUM	10MF	20%	3.15V
C607	1-123-822-00	ELECT	47MF	20%	10V
C608	1-131-361-00	TANTALUM	2.2MF	20%	20V
C609	1-161-013-00	CERAMIC	0.01MF	10%	25V
C610	1-130-482-00	MYLAR	0.0082MF	5%	50V
C611	1-130-483-00	MYLAR	0.01MF	5%	50V
C612	1-130-483-00	MYLAR	0.01MF	5%	50V
C613	1-130-485-00	MYLAR	0.015MF	5%	50V
C701	1-163-077-00	CERAMIC CHIP	0.1MF		50V
C702	1-123-618-00	ELECT	22MF	20%	6.3V
C703	1-163-161-00	CERAMIC CHIP	15PF	5%	50V
C704	1-163-161-00	CERAMIC CHIP	15PF	5%	50V
C705	1-163-169-00	CERAMIC CHIP	33PF	5%	50V
C706	1-123-617-00	ELECT	10MF	20%	16V
C801	1-124-255-00	ELECT	1MF	20%	50V
C802	1-124-238-00	ELECT	4.7MF	20%	25V
C803	1-123-618-00	ELECT	22MF	20%	6.3V
C804	1-131-418-00	TANTALUM	1MF	20%	10V
CK301	1-507-749-00	JACK, EXTENTION POWER (DC IN 6V)			
CP101	1-235-317-11	FILTER, LOW PASS			
CP102	1-235-318-11	FILTER, SP-SK			
CP201	1-235-317-11	FILTER, LOW PASS			
CP202	1-235-318-11	FILTER, SP-SK			
CP301	1-464-177-00	CIRCUIT UNIT, MUTING			
CP302	1-464-176-00	CIRCUIT UNIT, SWITCHING			
CP303	1-464-176-00	CIRCUIT UNIT, SWITCHING			
CP304	1-464-183-21	CONVERTER UNIT, DC-DC			

NOTE:

- The mechanical parts with no reference number in the exploded views are not supplied.
- Items marked "●" are not stocked since they are seldom required for routine service. Some delay should be anticipated when ordering these items.
- Due to standardization, parts with part numbers (Δ-ΔΔΔ-ΔΔΔ-XX or Δ-ΔΔΔΔ-ΔΔΔ-X) may be different from those used in the set.
- If there are two or more same circuits in a set such as a stereophonic machine, only typical circuit parts may be indicated and capacitors and resistors in other same circuits may be omitted.

CAPACITORS:

- All capacitors are in μF. Common capacitors are omitted. Refer to the following lists for their part numbers.
- MF: μF, PF: μμF.

COILS

- MMH : mH, UH : μH

SEMICONDUCTORS

- In each case, U : μ, for example:
- UA... : μA..., UPA... : μPA..., UPC... : μPC,
- UPD... : μPD...

ELECTRICAL PARTS

Ref.No.	Part No.	Description
D101	8-719-815-55	DIODE 1S1555
D201	8-719-815-55	DIODE 1S1555
D301	8-719-942-31	DIODE HZ3ALL
D302	8-719-815-55	DIODE 1S1555
D303	8-719-815-55	DIODE 1S1555
D701	8-719-100-05	DIODE 1S2837
D801	8-719-909-10	DIODE GL9PR10
D802	8-719-909-10	DIODE GL9PR10
D803	8-719-909-10	DIODE GL9PR10
D804	8-719-909-10	DIODE GL9PR10
D805	8-719-909-10	DIODE GL9PR10
FG901	A-3164-245-A	COIL SUB ASSY, FG
HE901	8-825-724-00	HEAD, ERASE EF-201-36
HRP901	8-825-529-60	HEAD, REC/PB (PA259-3602A)
IC101	8-752-006-80	IC CX20068
IC102	8-759-700-50	IC NJM386M
IC201	8-752-006-80	IC CX20068
IC202	8-759-700-50	IC NJM386M
IC301	8-759-700-43	IC NJM4558M
IC302	8-759-700-43	IC NJM4558M
IC601	8-759-909-45	IC CX20084
IC701	8-759-958-14	IC MSM58141RS
IC801	8-759-909-40	IC CX10043
J301	1-507-794-31	JACK, SMALL TYPE (WITH SWITCH)(MIC)
J302	1-507-929-21	JACK (LINE IN)
J303	1-507-929-21	JACK (LINE OUT)
J304	1-507-929-11	JACK (HEAD PHONES)
L101	1-408-682-00	MICRO INDUCTOR 10MMH
L102	1-408-704-00	MICRO INDUCTOR 33MMH
L201	1-408-682-00	MICRO INDUCTOR 10MMH
L202	1-408-704-00	MICRO INDUCTOR 33MMH
L301	1-408-557-00	MICRO INDUCTOR 3.3UH
M901	X-3305-830-1	MOTOR ASSY (MNF-1601A)
PH701	8-719-751-42	DIODE NJL5141E
Q101	8-729-204-83	TRANSISTOR 2SA1048-GR
Q102	8-729-205-84	TRANSISTOR 2SC2458L-BL
Q103	8-729-205-84	TRANSISTOR 2SC2458L-BL
Q104	8-729-205-84	TRANSISTOR 2SC2458L-BL
Q105	8-729-205-84	TRANSISTOR 2SC2458L-BL
Q106	8-729-205-84	TRANSISTOR 2SC2458L-BL
Q107	8-729-100-66	TRANSISTOR 2SC1623
Q108	8-729-102-03	TRANSISTOR 2SD1020
Q109	8-729-100-66	TRANSISTOR 2SC1623

ELECTRICAL PARTS

Ref.No.	Part No.	Description
Q201	8-729-204-83	TRANSISTOR 2SA1048-GR
Q202	8-729-205-84	TRANSISTOR 2SC2458L-BL
Q203	8-729-205-84	TRANSISTOR 2SC2458L-BL
Q204	8-729-205-84	TRANSISTOR 2SC2458L-BL
Q205	8-729-205-84	TRANSISTOR 2SC2458L-BL
Q206	8-729-205-84	TRANSISTOR 2SC2458L-BL
Q207	8-729-100-66	TRANSISTOR 2SC1623
Q208	8-729-102-03	TRANSISTOR 2SD1020
Q209	8-729-100-66	TRANSISTOR 2SC1623
Q301	8-729-245-83	TRANSISTOR 2SC2458
Q302	8-729-245-83	TRANSISTOR 2SC2458
Q303	8-729-800-83	TRANSISTOR 2SB808
Q304	8-729-245-83	TRANSISTOR 2SC2458
Q305	8-729-102-03	TRANSISTOR 2SD1020
Q306	8-729-102-03	TRANSISTOR 2SD1020
Q307	8-729-100-13	TRANSISTOR 2SC2001
Q308	8-729-800-83	TRANSISTOR 2SB808
Q309	8-729-245-83	TRANSISTOR 2SC2458
Q601	8-729-801-83	TRANSISTOR 2SB1013
Q701	8-729-100-66	TRANSISTOR 2SC1623
Q702	8-729-100-66	TRANSISTOR 2SC1623
Q703	8-729-100-66	TRANSISTOR 2SC1623
Q704	8-729-100-66	TRANSISTOR 2SC1623
Q801	8-729-245-83	TRANSISTOR 2SC2458
R101	1-247-879-00	CARBON 100K 5% 1/6W
R102	1-247-865-00	CARBON 27K 5% 1/6W
R103	1-247-855-00	CARBON 10K 5% 1/6W
R104	1-247-811-00	CARBON 150 5% 1/6W
R105	1-247-867-00	CARBON 33K 5% 1/6W
R106	1-247-835-00	CARBON 1.5K 5% 1/6W
R107	1-247-845-00	CARBON 3.9K 5% 1/6W
R108	1-247-863-00	CARBON 22K 5% 1/6W
R109	1-247-895-00	CARBON 470K 5% 1/6W
R110	1-247-903-00	CARBON 1M 5% 1/6W
R111	1-247-849-00	CARBON 5.6K 5% 1/6W
R112	1-247-829-00	CARBON 820 5% 1/6W
R113	1-247-877-00	CARBON 82K 5% 1/6W
R114	1-247-877-00	CARBON 82K 5% 1/6W
R115	1-247-809-00	CARBON 120 5% 1/6W
R116	1-247-849-00	CARBON 5.6K 5% 1/6W
R117	1-247-879-00	CARBON 100K 5% 1/6W
R118	1-247-819-00	CARBON 330 5% 1/6W
R119	1-247-857-00	CARBON 12K 5% 1/6W
R120	1-247-835-00	CARBON 1.5K 5% 1/6W
R121	1-247-881-00	CARBON 120K 5% 1/6W

ELECTRICAL PARTS

Ref.No.	Part No.	Description			
R122	1-247-851-00	CARBON	6.8K	5%	1/6W
R123	1-247-853-00	CARBON	8.2K	5%	1/6W
R124	1-247-857-00	CARBON	12K	5%	1/6W
R125	1-247-861-00	CARBON	18K	5%	1/6W
R126	1-247-895-00	CARBON	470K	5%	1/6W
R127	1-247-843-00	CARBON	3.3K	5%	1/6W
R128	1-247-850-00	CARBON	6.2K	5%	1/6W
R129	1-247-848-00	CARBON	5.1K	5%	1/6W
R130	1-247-874-00	CARBON	62K	5%	1/6W
R131	1-247-838-00	CARBON	2K	5%	1/6W
R132	1-247-867-00	CARBON	33K	5%	1/6W
R133	1-247-838-00	CARBON	2K	5%	1/6W
R134	1-247-861-00	CARBON	18K	5%	1/6W
R135	1-247-888-00	CARBON	240K	5%	1/6W
R136	1-247-888-00	CARBON	240K	5%	1/6W
R137	1-247-837-00	CARBON	1.8K	5%	1/6W
R138	1-247-862-00	CARBON	20K	5%	1/6W
R139	1-247-859-00	CARBON	15K	5%	1/6W
R140	1-247-867-00	CARBON	33K	5%	1/6W
R141	1-247-825-00	CARBON	560	5%	1/6W
R142	1-247-838-00	CARBON	2K	5%	1/6W
R143	1-247-835-00	CARBON	1.5K	5%	1/6W
R144	1-247-871-00	CARBON	47K	5%	1/6W
R145	1-247-873-00	CARBON	56K	5%	1/6W
R146	1-247-855-00	CARBON	10K	5%	1/6W
R147	1-247-839-00	CARBON	2.2K	5%	1/6W
R148	1-247-839-00	CARBON	2.2K	5%	1/6W
R149	1-247-865-00	CARBON	27K	5%	1/6W
R150	1-247-863-00	CARBON	22K	5%	1/6W
R151	1-247-821-00	CARBON	390	5%	1/6W
R152	1-247-787-00	CARBON	15	5%	1/6W
R153	1-247-847-00	CARBON	4.7K	5%	1/6W
R155	1-247-867-00	CARBON	33K	5%	1/6W
R156	1-247-873-00	CARBON	56K	5%	1/6W
R157	1-247-879-00	CARBON	100K	5%	1/6W
R158	1-247-845-00	CARBON	3.9K	5%	1/6W
R159	1-247-851-00	CARBON	6.8K	5%	1/6W
R160	1-247-855-00	CARBON	10K	5%	1/6W
R161	1-247-816-00	CARBON	240	5%	1/6W
R162	1-247-811-00	CARBON	150	5%	1/6W
R163	1-247-817-00	CARBON	270	5%	1/6W
R164	1-247-859-00	CARBON	15K	5%	1/6W
R165	1-247-851-00	CARBON	6.8K	5%	1/6W
R166	1-247-867-00	CARBON	33K	5%	1/6W
R167	1-247-879-00	CARBON	100K	5%	1/6W

NOTE:

- The mechanical parts with no reference number in the exploded views are not supplied.
- Items marked "●" are not stocked since they are seldom required for routine service. Some delay should be anticipated when ordering these items.
- Due to standardization, parts with part numbers (Δ-ΔΔΔ-ΔΔΔ-XX or Δ-ΔΔΔΔ-ΔΔΔ-X) may be different from those used in the set.
- If there are two or more same circuits in a set such as a stereophonic machine, only typical circuit parts may be indicated and capacitors and resistors in other same circuits may be omitted.

CAPACITORS:

- All capacitors are in μF. Common capacitors are omitted. Refer to the following lists for their part numbers.
- MF:μF, PF:μμF.

COILS

- MMH : mH, UH : μH

SEMICONDUCTORS

- In each case, U : v, for example:
 UA...: μA..., UPA...: μPA..., UPC...: μPC,
 UPD...: μPD...

WM-D6C/TC-D6C

ELECTRICAL PARTS

Ref.No.	Part No.	Description			
R168	1-247-877-00	CARBON	82K	5%	1/6W
R169	1-247-852-00	CARBON	7.5K	5%	1/6W
R301	1-247-857-00	CARBON	12K	5%	1/6W
R302	1-247-855-00	CARBON	10K	5%	1/6W
R303	1-247-857-00	CARBON	12K	5%	1/6W
R305	1-247-865-00	CARBON	27K	5%	1/6W
R306	1-247-863-00	CARBON	22K	5%	1/6W
R307	1-247-879-00	CARBON	100K	5%	1/6W
R308	1-247-847-00	CARBON	4.7K	5%	1/6W
R309	1-247-879-00	CARBON	100K	5%	1/6W
R310	1-247-863-00	CARBON	22K	5%	1/6W
R311	1-247-865-00	CARBON	27K	5%	1/6W
R312	1-247-823-00	CARBON	470	5%	1/6W
R313	1-247-821-00	CARBON	390	5%	1/6W
R314	1-247-847-00	CARBON	4.7K	5%	1/6W
R315	1-247-847-00	CARBON	4.7K	5%	1/6W
R316	1-247-795-00	CARBON	33	5%	1/6W
R317	1-247-871-00	CARBON	47K	5%	1/6W
R318	1-247-867-00	CARBON	33K	5%	1/6W
R319	1-247-867-00	CARBON	33K	5%	1/6W
R320	1-247-881-00	CARBON	120K	5%	1/6W
R321	1-247-831-00	CARBON	1K	5%	1/6W
R322	1-247-855-00	CARBON	10K	5%	1/6W
R601	1-247-840-00	CARBON	2.4K	5%	1/6W
R602	1-247-873-00	CARBON	56K	5%	1/6W
R603	1-214-781-00	METAL	150K	1%	1/4W
R604	1-214-781-00	METAL	150K	1%	1/4W
R605	1-247-855-00	CARBON	10K	5%	1/6W
R607	1-247-879-00	CARBON	100K	5%	1/6W
R608	1-247-855-00	CARBON	10K	5%	1/6W
R609	1-247-887-00	CARBON	220K	5%	1/6W
R610	1-247-876-00	CARBON	75K	5%	1/6W
R701	1-216-206-00	METAL CHIP	2.2K	5%	1/8W
R702	1-216-258-00	METAL CHIP	330K	5%	1/8W
R703	1-216-246-00	METAL CHIP	100K	5%	1/8W
R704	1-216-252-00	METAL CHIP	180K	5%	1/8W
R705	1-216-252-00	METAL CHIP	180K	5%	1/8W
R706	1-216-238-00	METAL CHIP	47K	5%	1/8W
R707	1-216-222-00	METAL CHIP	10K	5%	1/8W
R708	1-216-230-00	METAL CHIP	22K	5%	1/8W
R709	1-216-222-00	METAL CHIP	10K	5%	1/8W
R710	1-216-250-00	METAL CHIP	150K	5%	1/8W
R711	1-216-206-00	METAL CHIP	2.2K	5%	1/8W
R712	1-216-246-00	METAL CHIP	100K	5%	1/8W
R713	1-216-270-00	METAL CHIP	1M	5%	1/8W

ELECTRICAL PARTS

Ref.No.	Part No.	Description			
R714	1-216-230-00	METAL CHIP	22K	5%	1/8W
R715	1-216-278-00	METAL CHIP	2.2M	5%	1/8W
R716	1-216-180-00	METAL CHIP	180	5%	1/8W
R801	1-247-855-00	CARBON	10K	5%	1/6W
R802	1-247-855-00	CARBON	10K	5%	1/6W
R804	1-247-879-00	CARBON	100K	5%	1/6W
R805	1-247-855-00	CARBON	10K	5%	1/6W
R806	1-247-879-00	CARBON	100K	5%	1/6W
R807	1-247-855-00	CARBON	10K	5%	1/6W
R808	1-247-857-00	CARBON	12K	5%	1/6W
R809	1-247-873-00	CARBON	56K	5%	1/6W
R810	1-247-875-00	CARBON	68K	5%	1/6W
R811	1-247-847-00	CARBON	4.7K	5%	1/6W
R812	1-247-853-00	CARBON	8.2K	5%	1/6W
R813	1-247-783-00	CARBON	10	5%	1/6W
R814	1-247-813-00	CARBON	180	5%	1/6W
R815	1-247-813-00	CARBON	180	5%	1/6W
R816	1-247-813-00	CARBON	180	5%	1/6W
R817	1-247-813-00	CARBON	180	5%	1/6W
R818	1-247-813-00	CARBON	180	5%	1/6W
R819	1-247-831-00	CARBON	1K	5%	1/6W
RV101	1-226-710-00	RES, ADJ, SOLID	10K		
RV102	1-230-035-00	RES, ADJ, CARBON	10K		
RV201	1-226-710-00	RES, ADJ, SOLID	10K		
RV202	1-230-035-00	RES, ADJ, CARBON	10K		
RV301	1-230-275-11	RES, VAR, CARBON	50K/50K		
RV302	1-228-545-00	RES, VAR, SLIDE	50K/50K		
RV601	1-230-351-11	RES, ADJ, METAL GLAZE	50K		
RV602	1-228-607-00	RES, VAR, CARBON	20K		
RV603	1-230-351-11	RES, ADJ, METAL GLAZE	50K		
S301	1-554-029-00	SWITCH, SLIDE (REC/PB SELECT)			
S302	1-554-222-00	SWITCH, SLIDE (MIC ATT)			
S601	1-554-142-00	SWITCH, SLIDE (SPEED TUNE)			
S801	1-554-746-11	SWITCH, SLIDE (PEAK/BATT SELECT)			
S802	1-552-642-00	SWITCH (DOLBY NR)			
S803	1-552-642-00	SWITCH (TAPE SELECT)			
S901	1-553-226-00	SWITCH, LEAF (POWER)			
S902	1-552-181-00	SWITCH, LEAF (FWD MUTE)			
S903	1-553-198-00	SWITCH, LEAF (REC MUTE)			
T301	1-433-244-00	TRANSFORMER, BIAS OSCILLATOR			
X701	1-527-957-00	OSCILLATOR, CRYSTAL			

NOTE:

- The mechanical parts with no reference number in the exploded views are not supplied.
- Items marked "⚡" are not stocked since they are seldom required for routine service. Some delay should be anticipated when ordering these items.
- Due to standardization, parts with part numbers (Δ-ΔΔΔ-ΔΔΔ-XX or Δ-ΔΔΔΔ-ΔΔΔ-X) may be different from those used in the set.
- If there are two or more same circuits in a set such as a stereophonic machine, only typical circuit parts may be indicated and capacitors and resistors in other same circuits may be omitted.

CAPACITORS:

- All capacitors are in μF. Common capacitors are omitted. Refer to the following lists for their part numbers.
- MF: μF, PF: pF.

COILS

- MMH : mH, UH : μH

SEMICONDUCTORS

- In each case, U : μ, for example:
- UA...: μA..., UPA...: μPA..., UPC...: μPC,
- UPD...: μPD...

WM-D6C/TC-D6C

SERVICE MANUAL

WM-D6C:
US Model
Canadian Model
AEP Model
UK Model
E Model

TC-D6C:
US Model

No. 1
January, 1985

SUPPLEMENT

File this Supplement with the Service Manual.

Subject: DOLBY IC (IC101, 201) CHANGE

	(Former)	(New)
IC101, 102	CX20068	→ CX20218

Because of this change, main board and the circuit around DOLBY IC have been changed.

- New or former type can be identified by the part-number suffix of main board.

MAIN BOARD

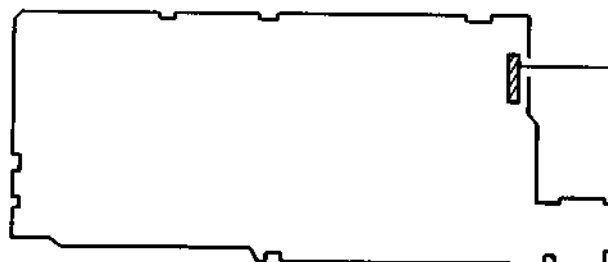

Former type: 1-611-494-11
New type: 1-611-494-12

The mounting diagram and the schematic diagram for the main board whose part-number suffix is 12 are given in this supplement.

As to information for the main board whose part-number suffix is 11, refer to the service manual previously issued.

- CHANGED PARTS Page 2-3
- Semiconductor lead layouts Page 3
- MOUNTING DIAGRAM Page 4-6
- SCHEMATIC DIAGRAM Page 7-10

STEREO CASSETTE-CORDER
SONY®

TC

● CHANGED PARTS

Note: Components for right channel is omitted. (Reference numbers are coded from 201.)





Ref. No.	Former (PC Board Suffix-11)				New (PC Board Suffix-12)			
	Description				Part No.	Description		
C103	TANTALUM	33 μ F	20%	6.3V	1-124-220-00	ELECT	33 μ F	20% 4V
C117	CERAMIC	100PF	10%	50V	1-102-108-00	CERAMIC	150PF	10% 50V
C121	CERAMIC	0.022 μ F	10%	25V	1-161-054-00	CERAMIC	0.018 μ F	10% 25V
C122	ELECT	2.2 μ F	20%	50V	1-124-255-00	ELECT	1 μ F	20% 50V
C123	TANTALUM	0.15 μ F	10%	35V	1-131-343-00	TANTALUM	0.22 μ F	10% 35V
C127	TANTALUM	0.15 μ F	10%	35V	1-131-341-00	TANTALUM	0.1 μ F	10% 35V
C128	TANTALUM	0.15 μ F	10%	35V	1-131-343-00	TANTALUM	0.22 μ F	10% 35V
C129	CERAMIC	0.0047 μ F	10%	25V	1-161-012-00	CERAMIC	0.0082 μ F	10% 25V
C134	CERAMIC	560PF	10%	50V	1-102-119-00	CERAMIC	0.0015 μ F	10% 50V
D101	DIODE	1S1555			_____			
D201	DIODE	1S1555			_____			
D301	DIODE	HZ3ALL			_____			
IC101	IC	CX20068			8-752-021-80	IC	CX20218	
IC201	IC	CX20068			8-752-021-80	IC	CX20218	
R134	CARBON	18K Ω	5%	1/6W	1-247-869-00	CARBON	39K Ω	5% 1/6W
R135	CARBON	240K Ω	5%	1/6W	1-247-872-00	CARBON	51K Ω	5% 1/6W
R136	CARBON	240K Ω	5%	1/6W	1-247-891-00	CARBON	330K Ω	5% 1/6W
R137	CARBON	1.8K Ω	5%	1/6W	1-247-831-00	CARBON	1K Ω	5% 1/6W
R138	CARBON	20K Ω	5%	1/6W	1-247-858-00	CARBON	13K Ω	5% 1/6W
R139	CARBON	15K Ω	5%	1/6W	1-247-858-00	CARBON	13K Ω	5% 1/6W
R141	CARBON	560 Ω	5%	1/6W	1-247-827-00	CARBON	680 Ω	5% 1/6W
R149	CARBON	27K Ω	5%	1/6W	1-247-859-00	CARBON	15K Ω	5% 1/6W
R150	CARBON	22K Ω	5%	1/6W	1-247-871-00	CARBON	47K Ω	5% 1/6W

Ref. No.	Former (PC Board Suffix-11)				New (PC Board Suffix-12)				
	Description				Part No.	Description			
R154					1-247-890-00	CARBON	300KΩ	5%	1/6W
R161	CARBON	240Ω	5%	1/6W	1-247-818-00	CARBON	300Ω	5%	1/6W
R170					1-247-903-00	CARBON	1MΩ	5%	1/6W
R171					1-216-198-00	METAL CHIP	1KΩ	5%	1/8W
R172					1-216-081-00	METAL CHIP	22KΩ	5%	1/10W
R312	CARBON	470Ω	5%	1/6W	1-247-826-00	CARBON	620Ω	5%	1/6W
R313	CARBON	390Ω	5%	1/6W	1-247-824-00	CARBON	510Ω	5%	1/6W

Service Manual P31, 32

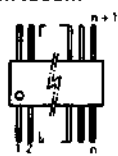
(345) LEVER, SPRING HOOK 3-557-405-00 ➔ 3-305-988-01

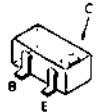
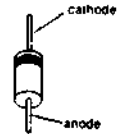
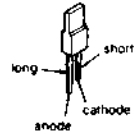
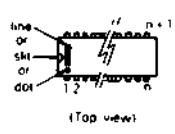
• **Semiconductor lead layouts**

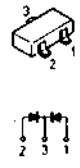
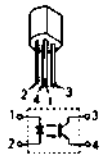
<p>CX10043 CX20218 CX20084 NJM386M NJM4558M</p> 	<p>2SA1048-GR 2SB808 2SC2458 2SC2458L-BL</p> 	<p>2SC1623</p> 	<p>1S1555</p> 	<p>GL9PR10</p> 
<p>MSM58141RS</p>  <p>(Top view)</p>	<p>2SB1013 2SC2001</p> 	<p>2SD1020</p> <p>letter side</p> 	<p>1S2837</p> 	<p>NJL5141E</p> 

Note: FOR MOUNTING DIAGRAM

- Color code of sleeving over the end of the jacket.

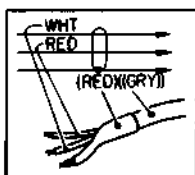

- ○ — : parts extracted from the component side.
- ● — : parts extracted from the conductor side.
- ■ : part mounted on the conductor side.
- ○ — : B + pattern
- —➔ : signal path
- —➔ : L-CH signal path
- —➔ : R-CH signal path

SCHEMATIC DIAGRAM

[MAIN BOARD]

[SPECTRAL SKEWING BOARD (L-CH)]

[REC EQ AMP]

[REC EQ MUTING]

R-CH IS THE SAME AS L-CH. (REF No. 200-)

[BIAS OSC]

[BIAS SWITCHING]

[RIPPLE FILTER]

[DOLBY B-C NR]

[LINE AMP]

[LED BOARD (1/3)]

[LED BOARD (1/3)]

[AUTO OFF BOARD]

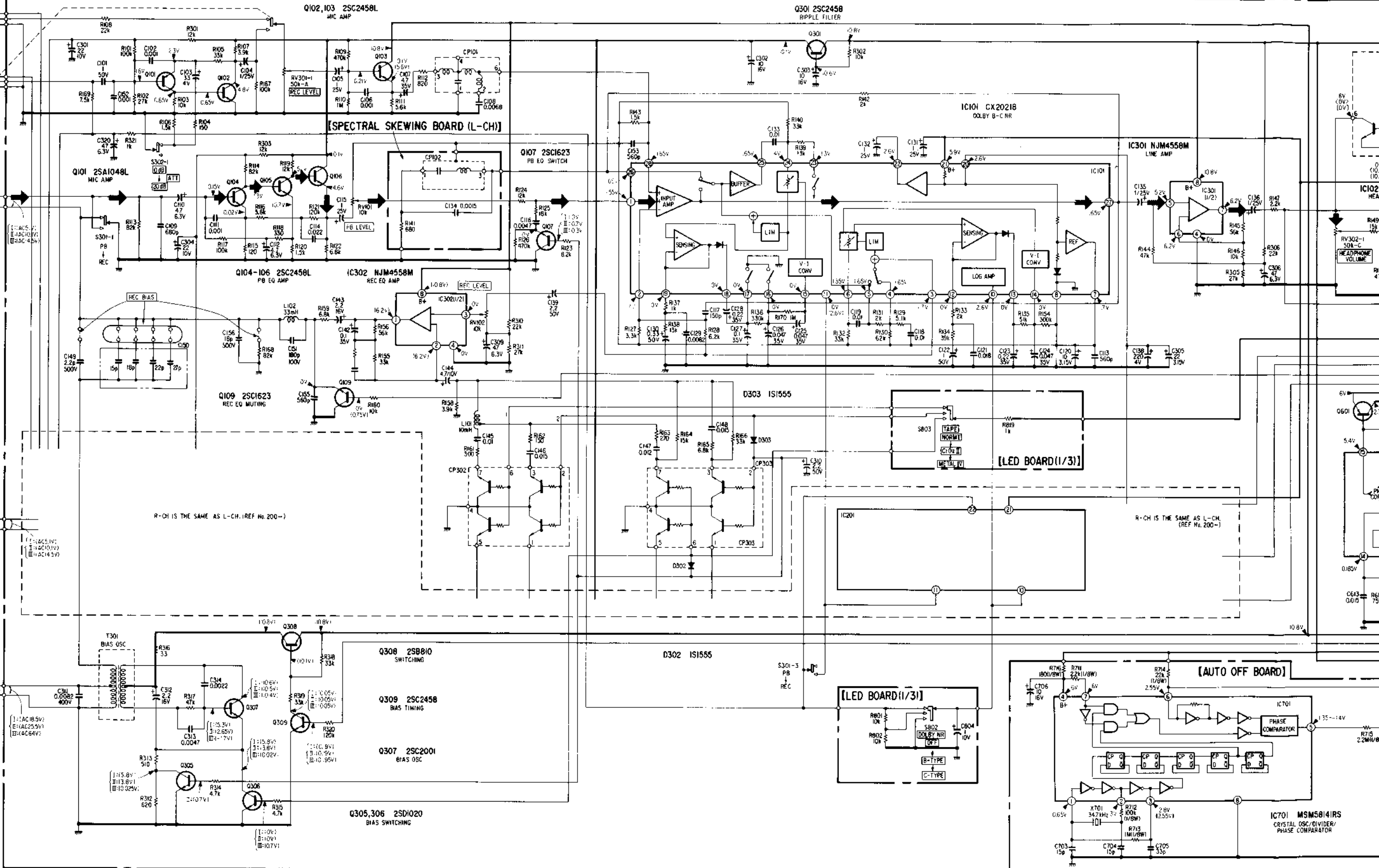

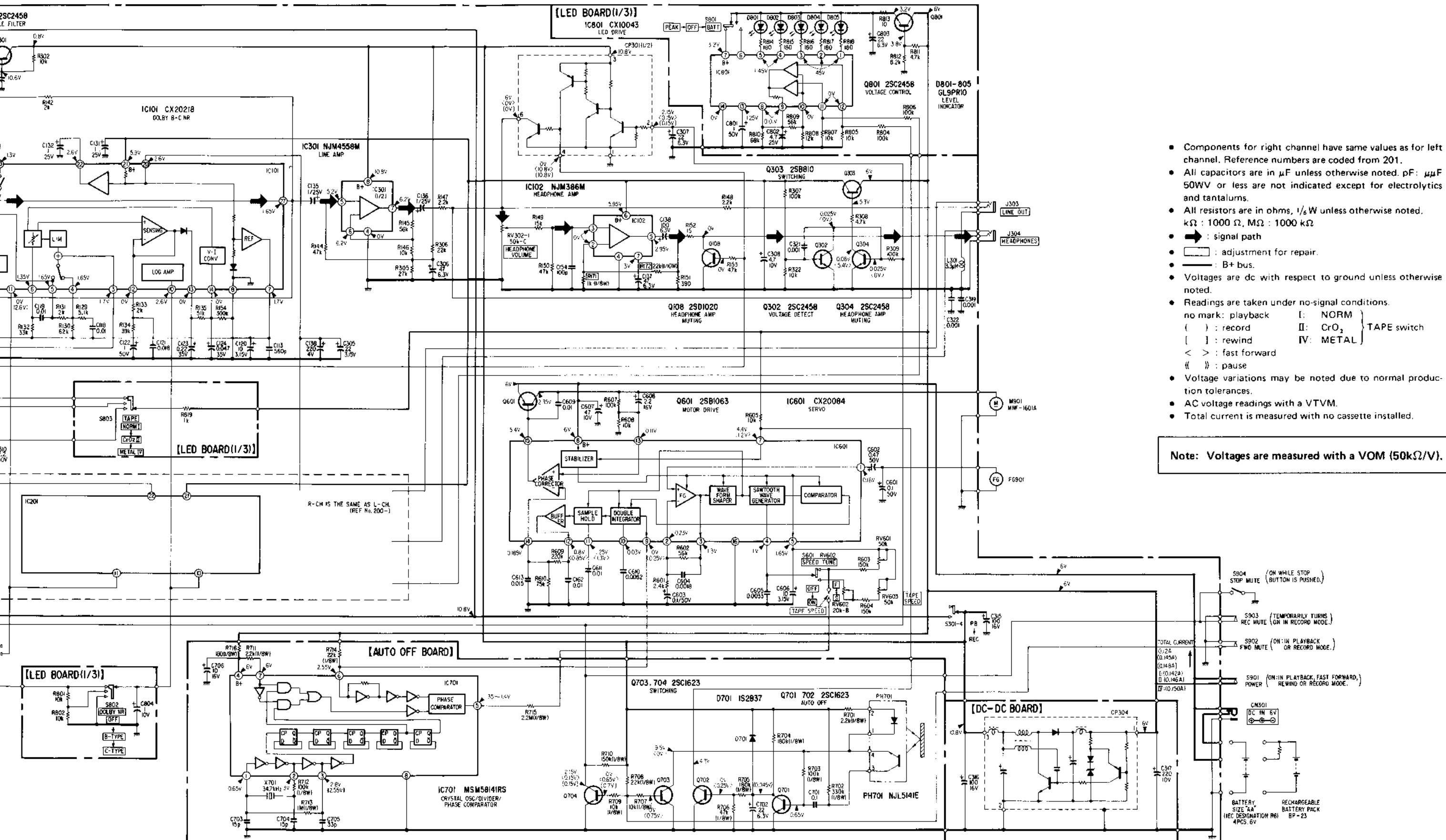

- Components for right channel have same values as for left channel. Reference numbers are coded from 201.
- All capacitors are in μF unless otherwise noted. pF: μpF 50WV or less are not indicated except for electrolytics and tantalums.
- All resistors are in ohms, $\frac{1}{4}$ W unless otherwise noted. k Ω : 1000 Ω , M Ω : 1000 k Ω
- \rightarrow : signal path
- \square : adjustment for repair.
- --- : B+ bus.
- Voltages are dc with respect to ground unless otherwise noted.
- Readings are taken under no-signal conditions.

no mark:	playback	I:	NORM
():	record	II:	CrO ₂
[]:	rewind	IV:	METAL
- << >> : fast forward
- << >> : pause
- Voltage variations may be noted due to normal production tolerances.
- AC voltage readings with a VTVM.
- Total current is measured with no cassette installed.

Note: Voltages are measured with a VOM (50k Ω /V).

A
B
C
D
E
F
G
H
I
J