

TC-D3/WM-D3

SERVICE MANUAL

Refer to MDR-W20L/B Service Manual issued previously for information of headphones supplied with this set.



TC-D3:
FRANCE Model
UK Model
WM-D3:
US Model
Canadian Model
AEP Model
ET Model

● Photo: WM-D3

SPECIFICATIONS

Recording system	4-track, 2-channel stereo
Wow and flutter	±0.13% (DIN)
	0.08% WRMS (NAB)
Fast winding time	Approx. 2 min. with Sony Cassette HF-60
Frequency response (DOLBY NR OFF)	60-15,000 Hz ±3 dB with TYPE I (Sony HF-S) or TYPE II (Sony UCX-S) cassette
	40-16,000 Hz with TYPE I (Sony HF-S) or TYPE II (Sony UCX-S) cassette

S/N (NAB, at peak level)

Type of Cassette	TYPE I (Sony HF-S)	TYPE II (Sony UCX-S)
Dolby NR		
ON (B-type)	62 dB	64 dB
OFF	55 dB	57 dB

Total harmonic distortion

1.0% with Sony UCX-S cassette

Input	Line input/microphone (stereo minijack) × 1 (the same jack) microphone sensitivity 0.3 mV (-68 dB), plug in power type, for low impedance microphone Line input sensitivity 77.5 mV (47 kilohms)
Output	Line output jack (stereo minijack) × 1 output level 0.25 V (less than 4.7 kilohms) headphones (stereo minijack) × 1 load impedance 8-300 ohms
Power output (DC)	20 mW + 20 mW (at 10% harmonic distortion, load impedance 32 ohms)

Battery life (hours)

Batteries	Recording		Tape playback (power output 0.5 mW + 0.5 mW)
	TYPE I (Normal)	TYPE II (CrO ₂)	
Sony SUM-3 (NS) New Super batteries	Approx. 2.5	Approx. 2	Approx. 3.5
Sony Eveready AM3 alkaline batteries	Approx. 5	Approx. 4	Approx. 7

Tape Transport Mechanism Type MT-WM-D3-24

Power requirements	3V dc Two IEC designation R6 batteries (size AA) DC IN 3V jack can be used with the following: Sony AC-D2 ac power adaptor (optional) for use on 120V ac, 60 Hz (available in US, Canadian model) for use on 240V ac, 50 Hz (available in UK, model) for use on 220V ac, 50 Hz (available in AEP, FRANCE model) for use on 100V ac, 120V ac or 220V ac, 50/60 Hz* (available in ET model) * There are three types: one is for 100V ac, one is for 120V ac and one is for 220V ac, Sony DCC-70 car battery cord (optional) for use with 12 V car battery
Dimensions	Approx. 124.2 × 34.4 × 82.3 mm (w/h/d) (5 × 1 1/8 × 3 1/4 inches) not incl. projecting parts and controls Approx. 125.4 × 37.3 × 82.3 mm (w/h/d) (5 × 1 1/2 × 3 3/8 inches) incl. projecting parts and controls
Weight	Approx. 370 g (13.1 oz) incl. batteries, not incl. other accessories
Supplied accessories	Stereo headphones (open-air type) (1) Electret condenser stereo microphone (1) Plug adaptor (1) Connecting cord (1) Carrying case and carrying strap (1 set)

'Dolby' and the double-D symbol are the trade marks of Dolby Laboratories Licensing Corporation. Noise reduction system manufactured under license from Dolby Laboratories Licensing Corporation.

STEREO CASSETTE-CORDER
SONY®

FEATURES

- Dolby* B-type system reduces tape hiss noise.
- Disc drive capstan servo system assures stable tape transport, reducing wow and flutter.
- Tape selector offers two positions.
- 5-LED peak/battery indicator shows both the peak level and the battery strength.
- Plug-in power type microphone jack can supply power to the supplied microphone.
- Amorphous head for recording/playback provides a wider dynamic range.
- Stereo minijacks can easily be connected to audio components.

SERVICING NOTES

● Flexible Circuit Board Repairing

1. Keep the temperature of the soldering iron at $270^{\circ} \pm 10^{\circ}\text{C}$ during repairing.
You can maintain the temperature of the soldering iron around 270°C by using the thermal controller.
2. Do not touch the soldering iron more than 4 seconds or 3 times on the same conductor of the circuit board.
3. Do not apply force on the conductor when soldering or unsoldering.

Tip of soldering iron



● **Replacing chip components**

All chip components should be connected and disconnected, using a tapered soldering iron [temperature of the iron tip: less than 280°C (536°F)], a pair of tweezers and braided wire.

Precautions for replacement

1. Do not disconnect the chip component forcefully. Otherwise, the pattern may peel off.
2. Never re-use a disconnected chip component. Dispose of all old chip components.
3. To protect the chip component, heating time for attaching the component should be within 3 seconds.

○ **Removing chip components**

(1) **Removing solder at electrode**

Remove the solder at the electrode, using a thin braided wire. Do not remove the solder of the part (chip component) attached adjacent to the electrode.

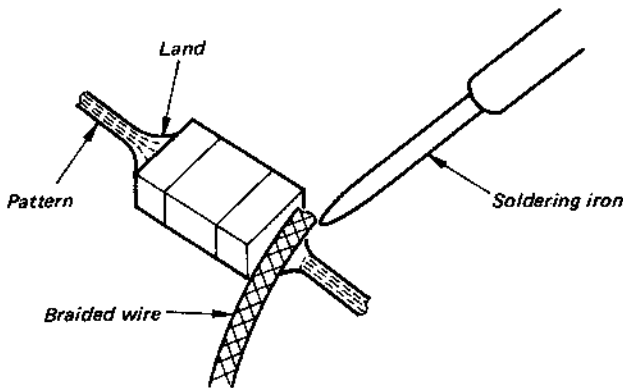

(2) **Disconnecting chip components**

Turn the tweezers with the soldering iron alternately applied to both electrodes, and the chip component will be disconnected. Take careful precautions while disconnecting, because if the chip component is forcefully removed the land may peel off. Never re-use a disconnected chip component.

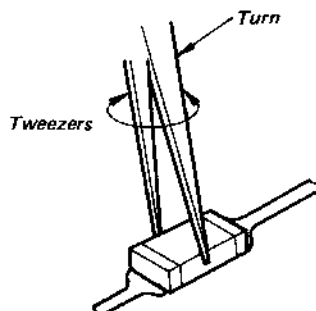

(3) **Smoothing the soldered surface**

After disconnecting the chip component, remove the solder by using a braided wire to smooth the land surface.

○ **Connecting chip components**

The value of chip components is not displayed on the main body. Take due precautions to avoid mixing new chip components with other ones.

(1) **Applying solder to land on one side**

Apply a thin layer of solder to the land on one side where the chip component is to be connected. Too much solder may cause bridging.



(2) **Speedy soldering**

Hold the chip component at the desired position, using tweezers, and apply the soldering iron in the arrow-marked direction. To protect the chip component, heating time should be within 3 seconds.

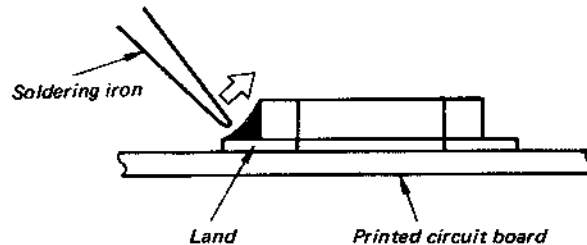

(3) **Speedy soldering of electrode on the other side**

Solder the electrode on the other side in the same way as in (2) above.

PARTS IDENTIFICATION

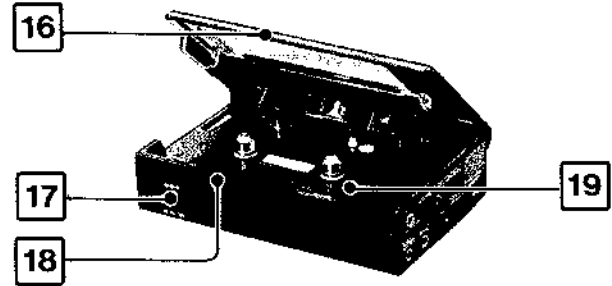
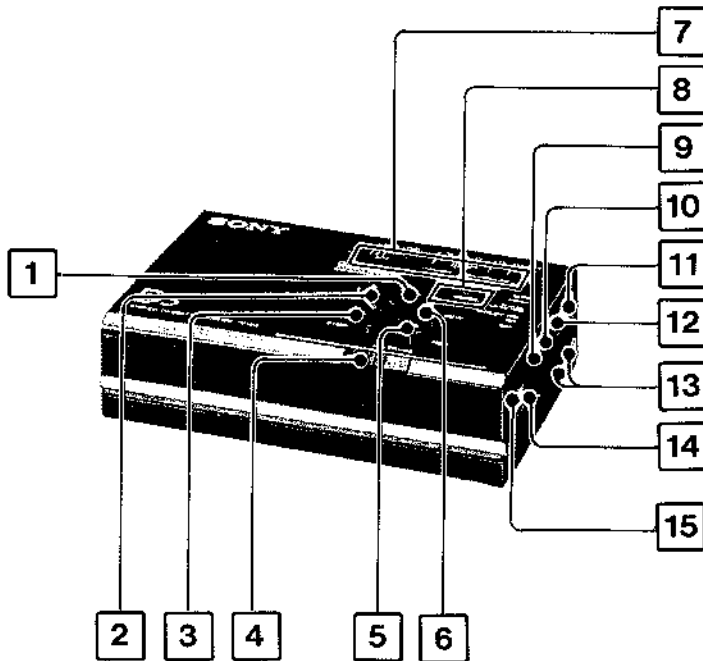

- 1** ◀◀ FF (fast forward) button
- 2** ◀ PLAY (playback) button
- 3** ■ STOP button
- 4** PAUSE knob
Slide it in the direction of the arrow, and the tape stops momentarily. To restart, slide it back to the original position.
- 5** ● REC (record) button
- 6** ▶▶ REW (rewind) button
- 7** Peak level/battery meter and indication selector
PEAK LEVEL: shows the recording level.
BATT: shows the battery condition
OFF: no indication
- 8** Tape counter and reset button
Use the counter to index the tape contents. Push the reset button to set the counter to 000.
- 9** DOLBY NR selector
- 10** TAPE selector
NORM: TYPE I (normal) tape
CrO₂/METAL (PB) (playback): When playing back and recording with TYPE II (CrO₂) tape, or when playing back with TYPE IV (metal) tape.
- 11** LINE OUT (PB ONLY) (playback only) jack
- 12** PHONES (headphones) jack
- 13** LINE IN/MIC (line input/microphone) jack and selector
- 14** REC LEVEL (recording level) control
- 15** PHONE VOL (headphones volume) control

- 16** Cassette holder
- 17** DC IN 3 V (external power input) jack
Connect the ac power adaptor or car battery cord.
- 18** OPEN catch
- 19** Battery compartment

SECTION 1
BLOCK DIAGRAM

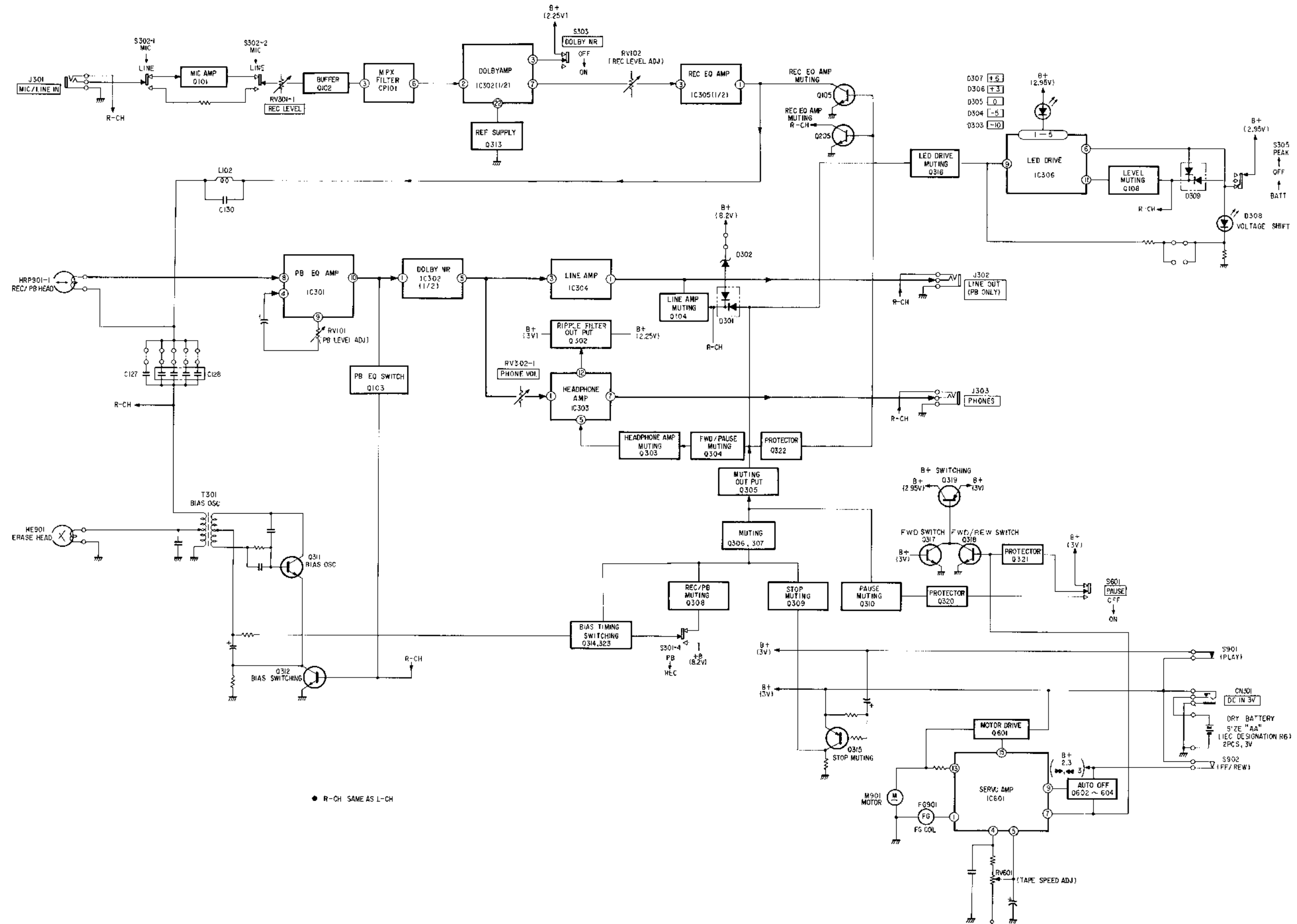

SECTION 2
DISASSEMBLY

• Follow the disassembly procedure in order given.

CONTROL PANEL REMOVAL

CASSETTE PANEL REMOVAL

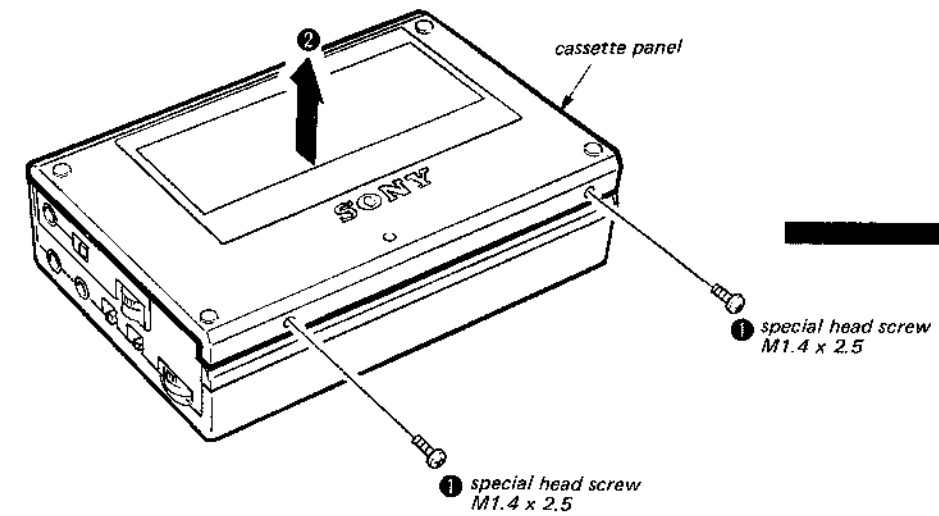
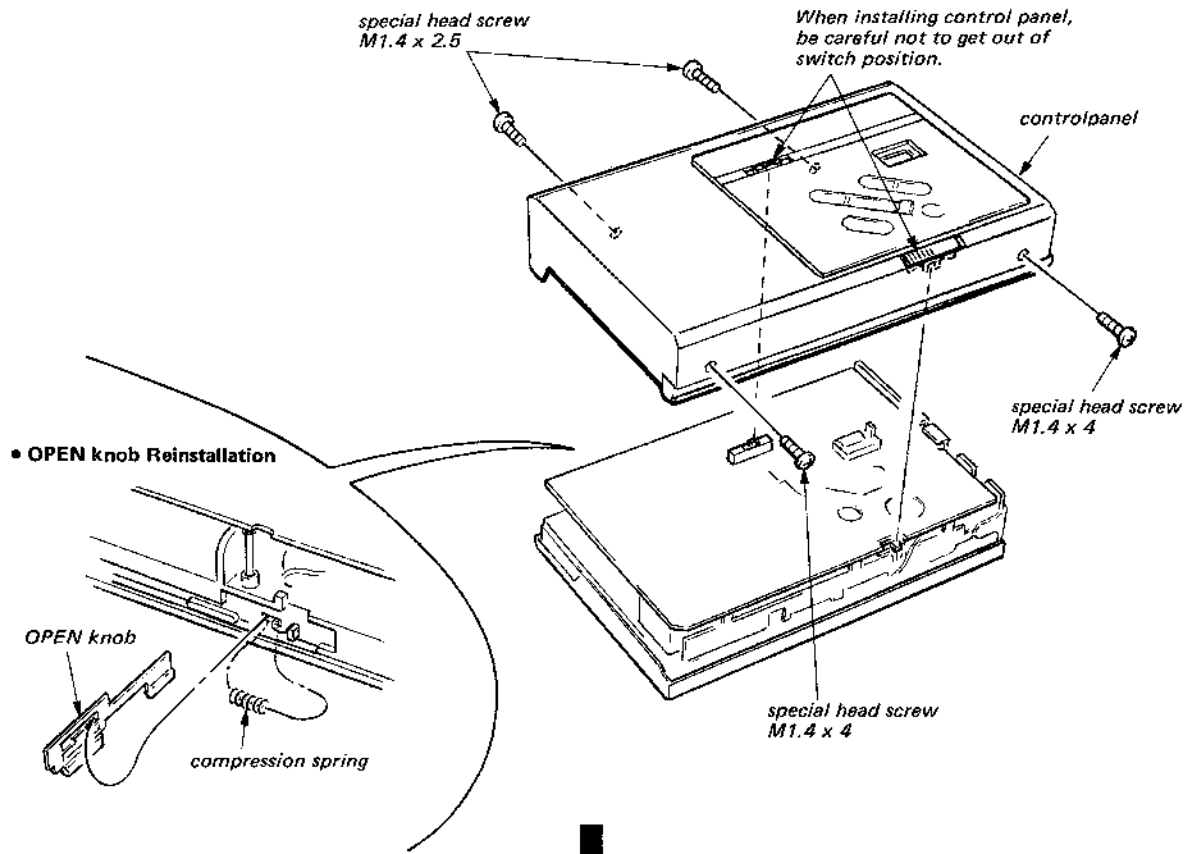

MAIN BOARD REMOVAL

SIDE PANEL

REC BOARD REMOVAL

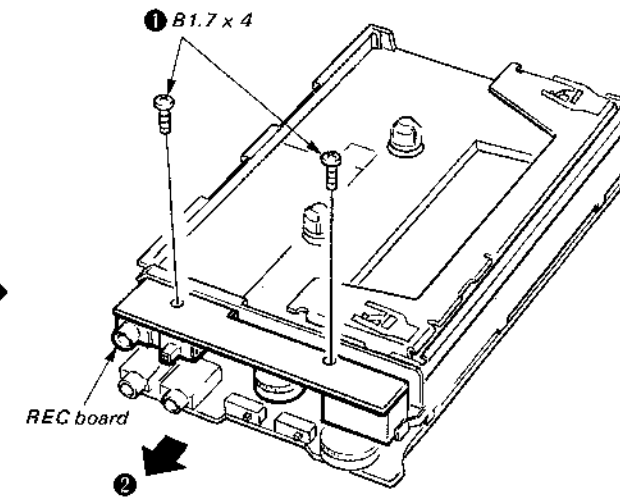
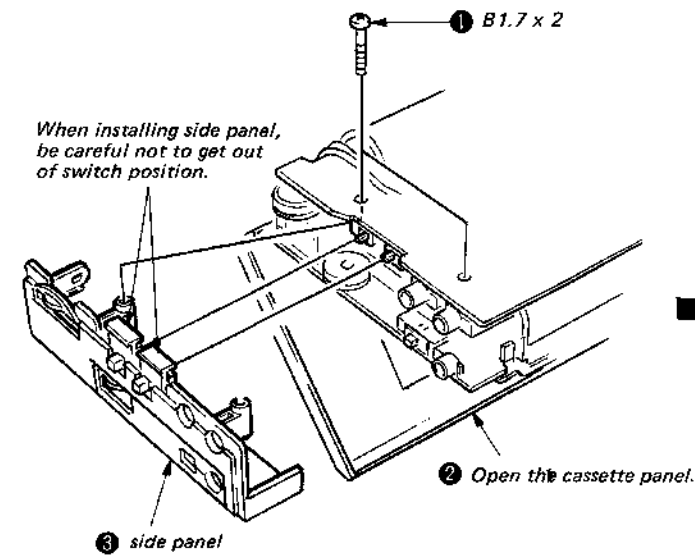
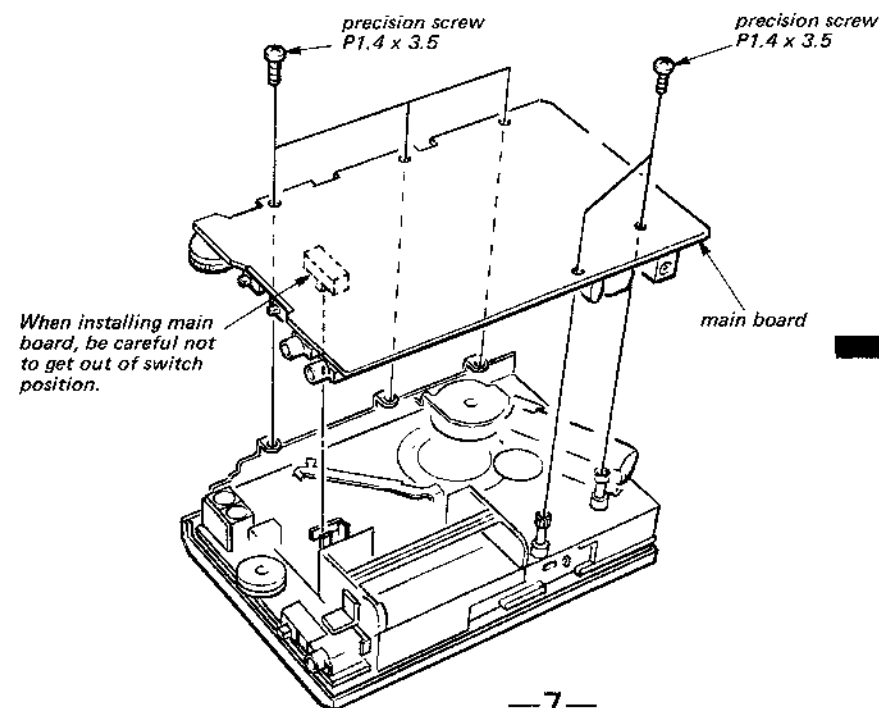

MECHANISM DECK REMOVAL

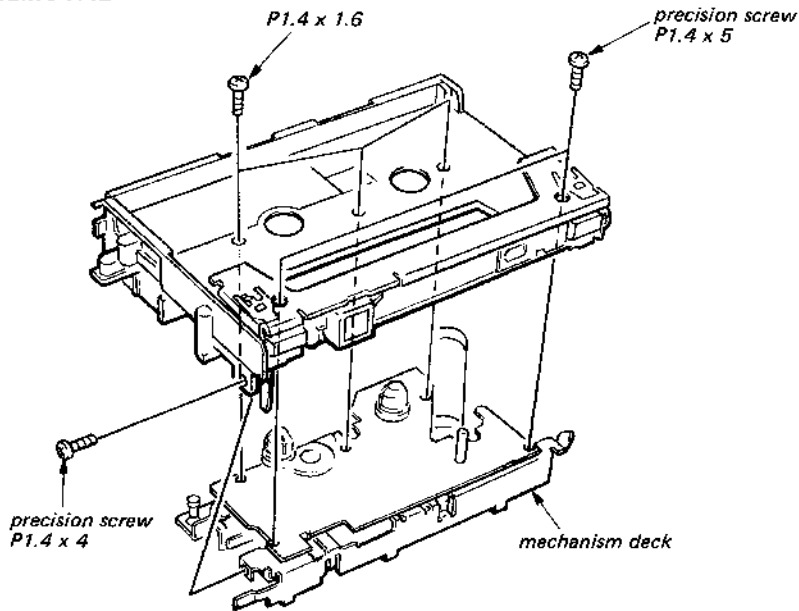

REC/PB HEAD (HRP901), ERASE HEAD (HE901), PINCH ROLLER REMOVAL

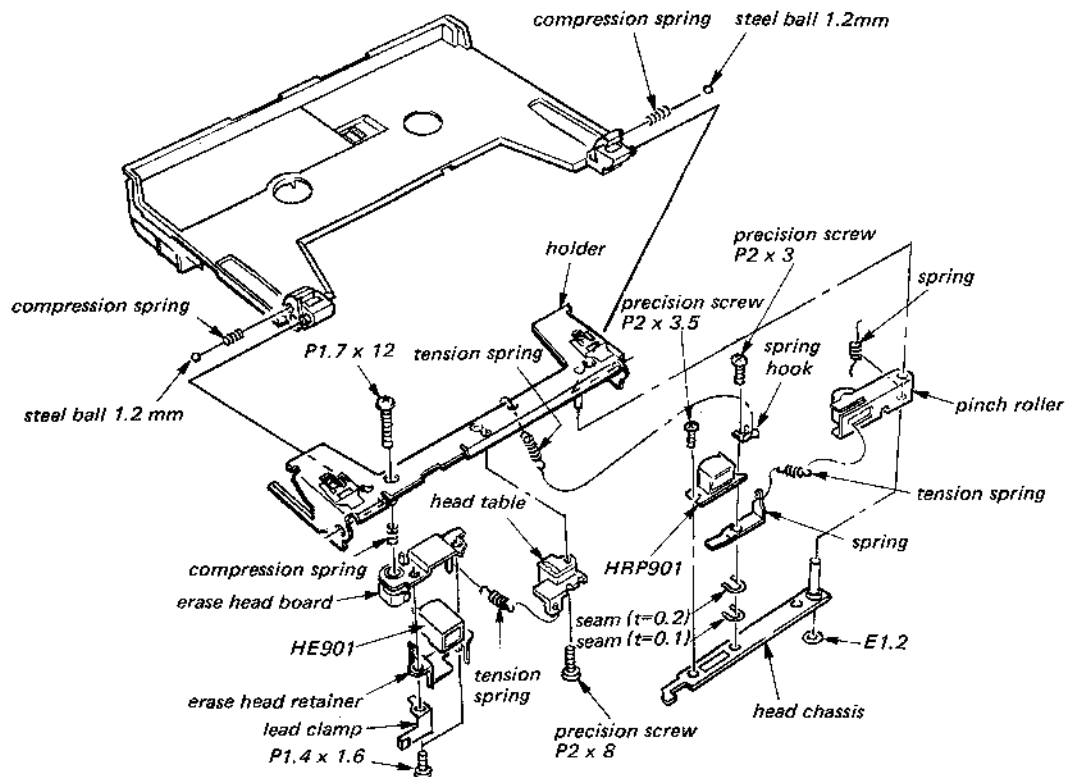

**SECTION 3
ADJUSTMENTS**

3-1. MECHANICAL ADJUSTMENTS AND MEASUREMENT

PRECAUTION

1. Clean the following parts with a danatured-alcohol-moistened swab:
 record/play back head pinch roller
 erase head rubber belts
 capstan
2. Demagnetize the record/playback head with a head demagnetizer. (Do not bring the head demagnetizer close to the erase head.)
3. Do not use a magnetized screwdriver for the adjustments.
4. After the adjustments, apply suitable locking compound to the parts adjusted.
5. The adjustments should be performed with the rated power supply voltage unless otherwise noted.

Perform with 2.5 V DC power

Torque Measurement

Torque	Meter Reading	Torque Meter
Forward	22 – 46 g-cm (0.30 – 0.63 oz-inch)	CQ-102C
Fast Forward and Rewind	More than 65 g-cm (More than 0.89 oz-inch)	CQ-201B
Back Tension	1 – 3 g-cm (0.014 – 0.041 oz-inch)	CQ-102C

Tape Tension Measurement

Meter	Meter Reading
CQ-403A	100 – 150 g (3.53 – 5.29 oz)

Pinch Roller Pressure Measurement

Procedure:

– playback mode –

1. Pull the spring scale in the direction of the arrow.
2. Slowly return the pinch roller and read the spring scale just when the pinch roller starts to rotate.

Specifications:

150 ± 20g

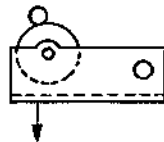

Head Height Adjustment

Procedure:

1. Prepare an adjustment cassette as shown below.

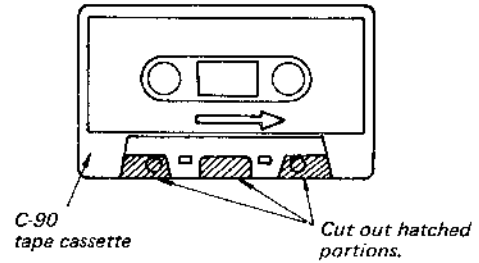

2. In record mode and viewing from the front, adjust the head heights to eliminate tape curl and tape twist at arrowed portions.

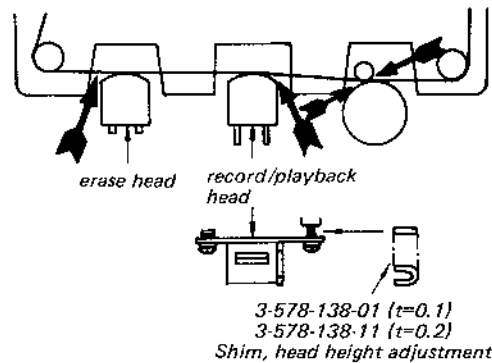

3. If necessary, adjust the height of the erase head by turning the adjustment screw.

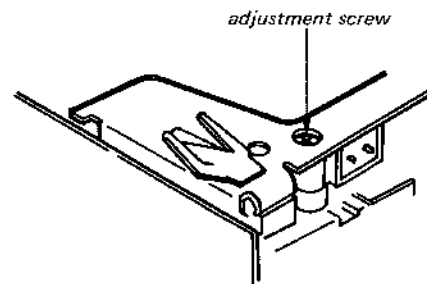

4. Apply locking compound on adjustment screw.

3-2. ELECTRICAL ADJUSTMENTS

Note: The adjustment should be performed in the order given in this service manual. The adjustments should be performed for both L-CH and R-CH.

- Set the TAPE switches according to the tape as follows.

Tape	TAPE SELECT Switch
CS-121	NORMAL
CS-221	CrO ₂

- Switches and controls should be set as follows unless otherwise specified.

DOLBY NR OFF
 TAPE NORM

- Standard Record:

Deliver the standard input signal level to the input jack and set the REC LEVEL control to obtain the standard output signal level.

— Record Mode —

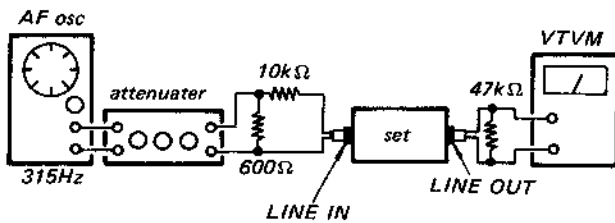

Standard Input Level

	LINE IN	MIC IN
source impedance	10kΩ	300Ω
input level	0.25V (-10dB)	0.775mV (-60dB)

Standard Output Level

	LINE OUT
load impedance	47kΩ
output level	0.44V (-5dB)

Playback Head Azimuth Adjustment

Procedure:

1. Mode: playback

test tape
 P-4-A100
 (100kHz, -10 dB)

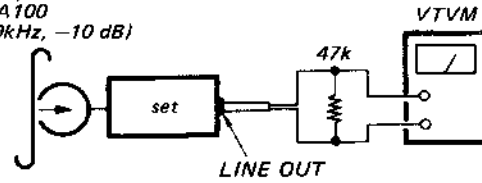

2. Turn the adjustment screw for the maximum output levels. If these levels do not match, turn the adjustment screw where both of output levels match together within 0.5 dB.

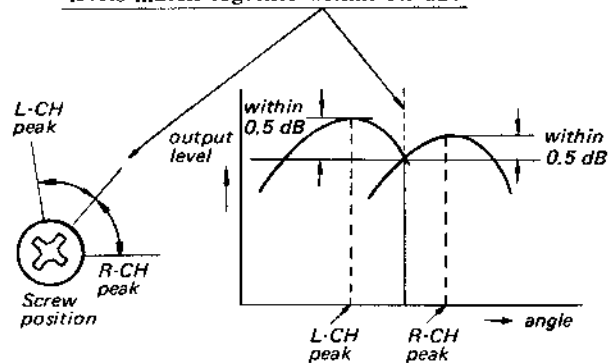

3. Phase Check

Mode: playback

test tape
 P-4-A063
 (6.3 kHz, -10 dB)

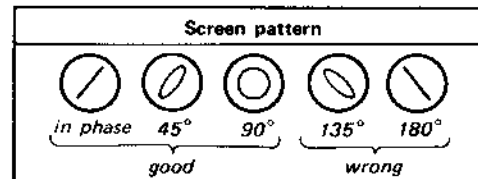
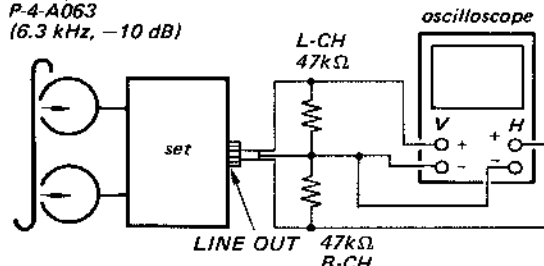

Adjustment Location:

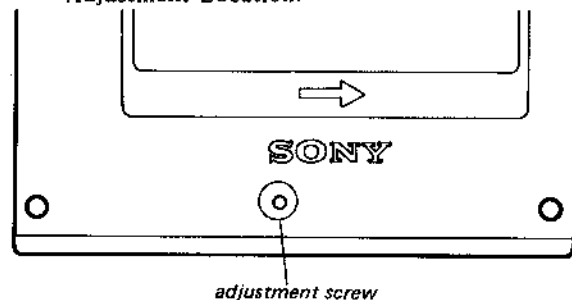

Tape Speed Adjustment

Setting:

VOLUME knob: center click

Procedure:

Mode: playback

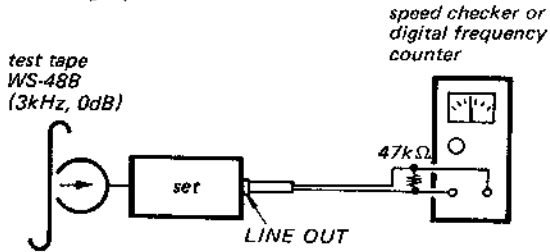

Specifications:

Speed checker	Digital frequency counter
± 2 %	2,940 – 3,060 Hz

Adjustment Location:

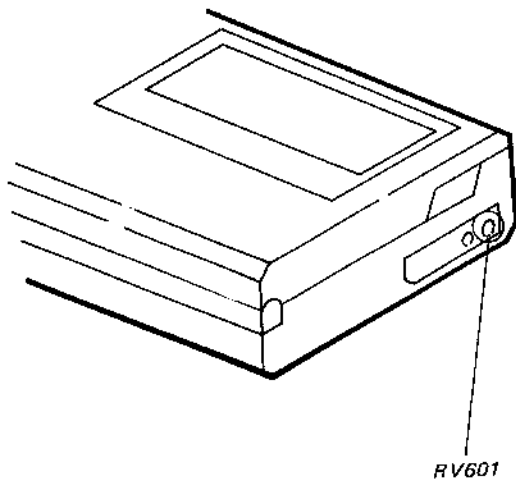

Playback Level Adjustment

Setting:

TAPE select switch : NORM

DOLBY NR switch : OFF

Procedure:

Mode: playback

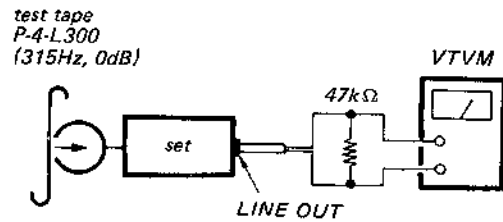

Adjust RV101 (L-CH) and RV201 (R-CH) for 245 – 256 mV (–10 to +9.6 dB) reading on VTVM.

Adjustment Location: main board

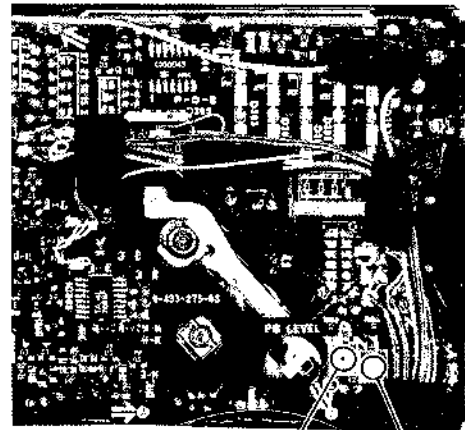

RV101
(L-CH)

RV201
(R-CH)

Record Bias Adjustment

Setting:

- LINE IN/MIC switch: MIC
- REC LEVEL: STANDARD RECORD
(See page 11.)

Procedure:

1. Mode: record

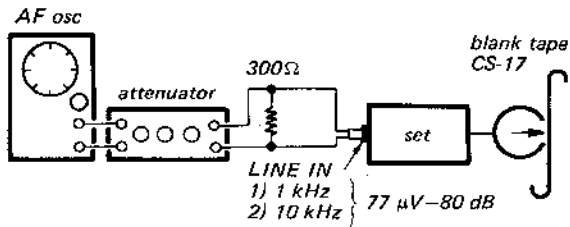

Record 315 Hz and 10 kHz signals.

2. Mode: playback

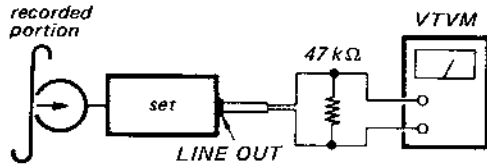

3. Play back 1 kHz, 10 kHz and adjust by changing the pattern to obtain the specified LINE OUT level. (When the specified value cannot be obtained by bridging only one pattern, then bridge another pattern.)

When the 10 kHz output is high
increase the capacitance

When the 10 kHz output is low
decrease the capacitance

Specification:

Within 10 kHz level difference ± 1.0 dB relative to 1 kHz.

Adjustment Location:

- main board - (Conductor Side)

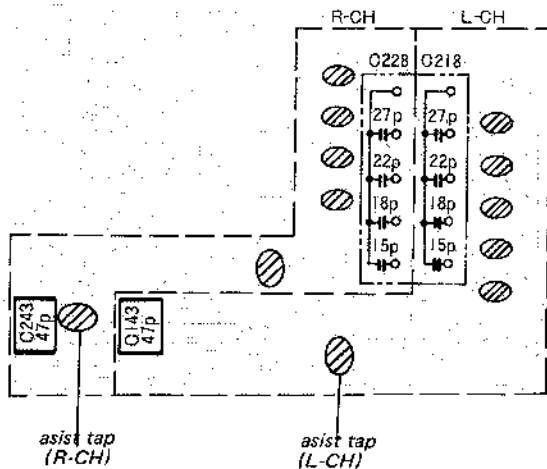

Record Level Adjustment

Setting:

- LINE IN/MIC switch: MIC
- REC LEVEL: STANDARD RECORD
(See page 11.)

Procedure:

1. Mode: record

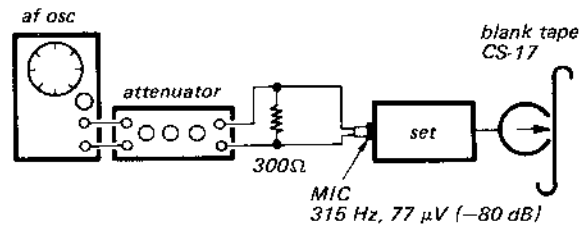

2. Set TAPE selector to NORMAL.
3. Record -80 dB ($0.77 \mu\text{V}$), 315 Hz signal in a blank tape (C3-17).
4. Play back the recorded tape in step 2.
5. Mode: playback

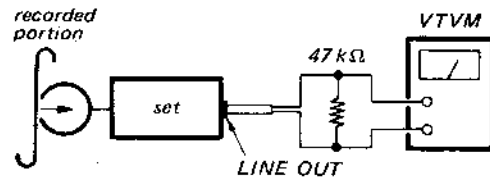

6. Repeat steps 2 and 3 and adjust RV102 (L-CH), RV202 (R-CH) so that the LINE OUT level is -10.3 dB.
7. Set TAPE select switch to CrO₂.
8. Repeat steps 1 to 4 also for CS-25 and obtain the specified value.

Tape	Specification	TAPE SELECT
CS-10	$-10.3 \text{ dB} \pm 0.5 \text{ dB}$	NORMAL/CrO ₂
CS-25	$-10.3 \text{ dB} \pm 2 \text{ dB}$	NORMAL/CrO ₂

Adjustment Location:

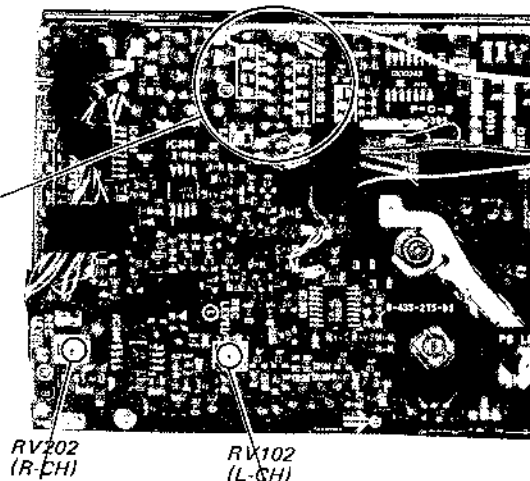

• Semiconductor lead layouts

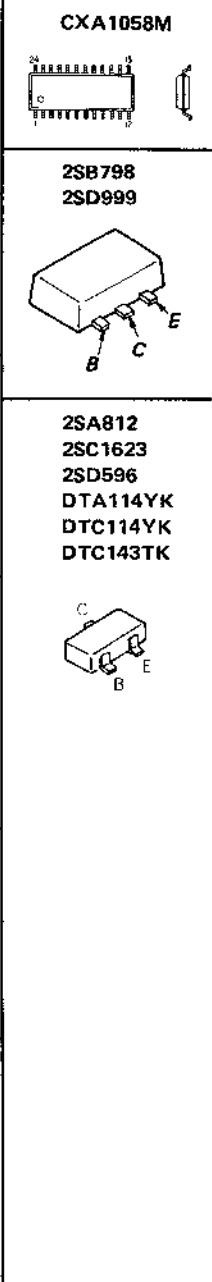
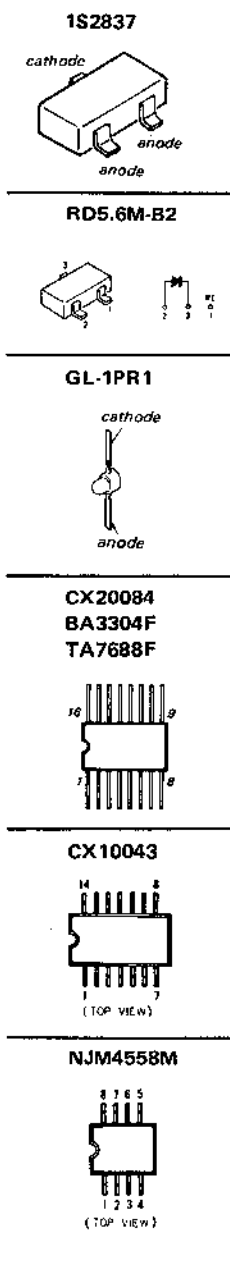

Ref No.	Location	Ref No.	Location
D301	F-18	Q205	H-16
D302	F-18	Q206	H-19
D303	D-22	Q207	H-18
D304	D-22	Q208	B-23
D305	D-23	Q301	E-19
D306	D-24	Q302	G-18
D307	D-24	Q303	G-18
D308	D-21	Q304	G-18
D309	D-21	Q305	F-17
		Q306	F-17
IC301	H-3	Q307	F-17
IC302	F-8	Q308	G-16
IC303	G-19	Q309	F-16
IC304	E-17	Q310	F-17
IC305	H-18	Q311	C-16
IC306	C-21	Q312	B-17
IC601	D-15	Q313	E-24
		Q314	F-22
Q101	D-28	Q315	F-16
Q102	I-27	Q316	C-19
Q103	H-8	Q317	I-21
Q104	E-18	Q318	I-21
Q105	H-16	Q319	D-20
Q106	H-20	Q320	G-17
Q107	H-18	Q321	I-6
Q108	B-23	Q322	G-17
Q201	D-30	Q323	F-22
Q202	J-27	Q601	E-14
Q203	H-8	Q602	C-15
Q204	E-18	Q603	C-15
		Q604	C-14

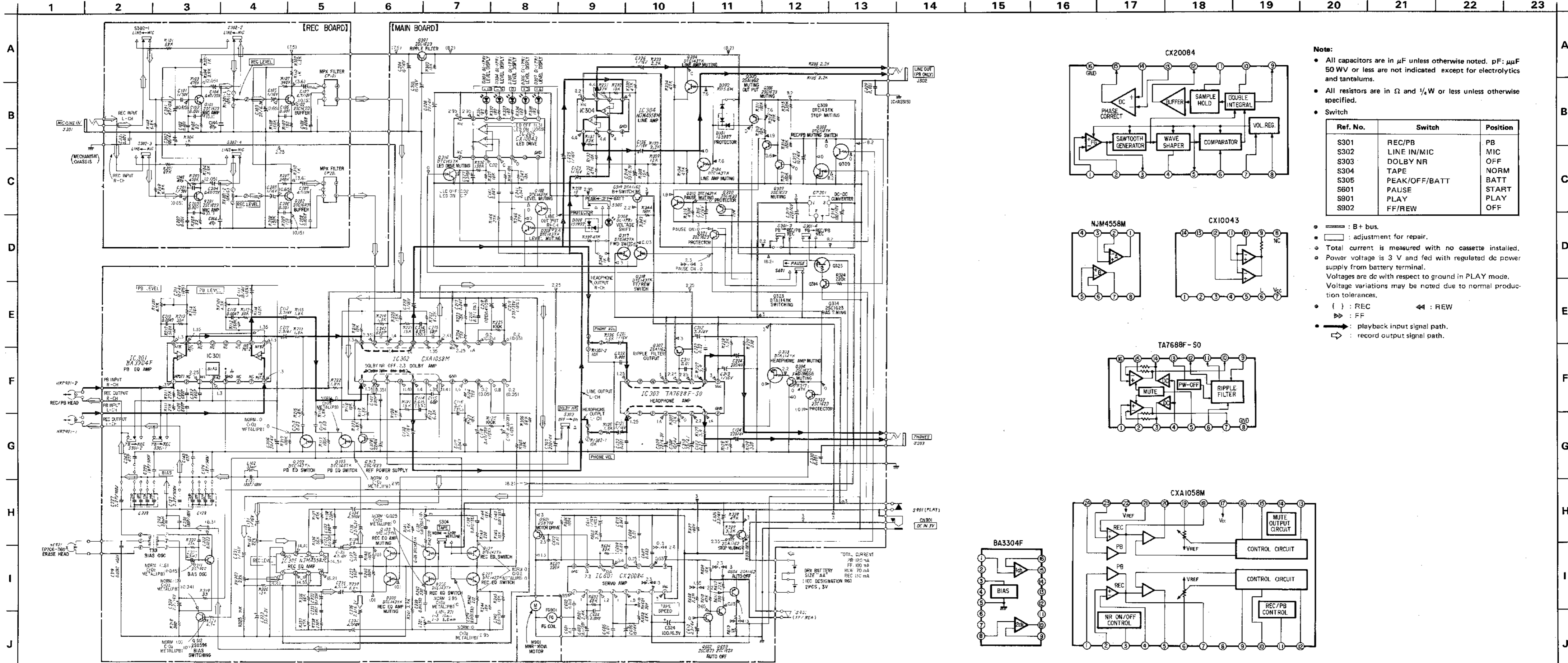

Note:

- All capacitors are in μF unless otherwise noted. pF: μpF 50 WV or less are not indicated except for electrolytics and tantalums.
- All resistors are in Ω and $\frac{1}{4}\text{W}$ or less unless otherwise specified.
- Switch

Ref. No.	Switch	Position
S301	REC/PB	PB
S302	LINE IN/MIC	MIC
S303	DOLBY NR	OFF
S304	TAPE	NORM
S305	PEAK/OFF/BATT	BATT
S601	PAUSE	START
S901	PLAY	PLAY
S902	FF/REW	OFF

- : B+ bus.
- : adjustment for repair.
- Total current is measured with no cassette installed.
- Power voltage is 3 V and fed with regulated dc power supply from battery terminal.
- Voltages are dc with respect to ground in PLAY mode. Voltage variations may be noted due to normal production tolerances.
- : REC
- : REW
- : FF
- : playback input signal path.
- : record output signal path.

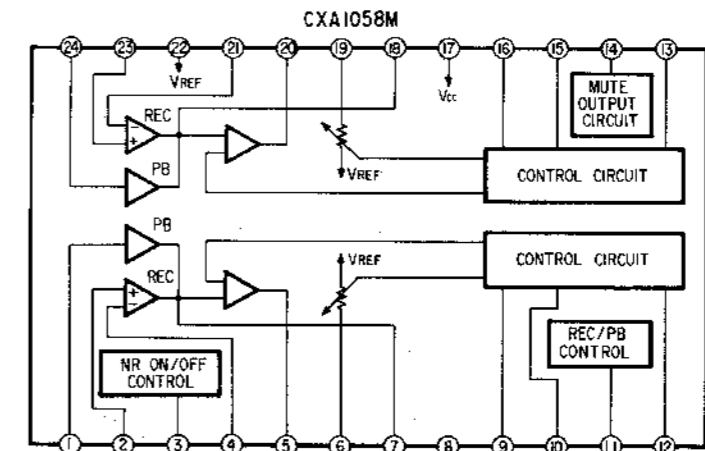
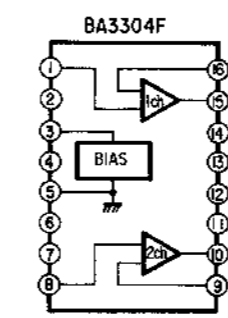
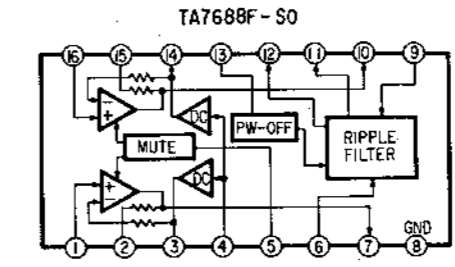
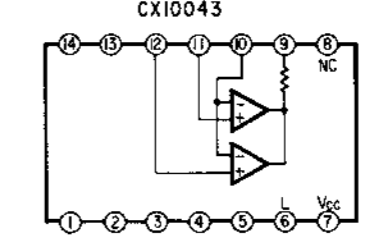
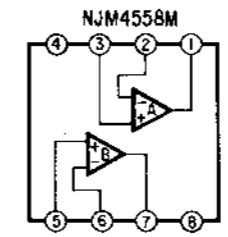
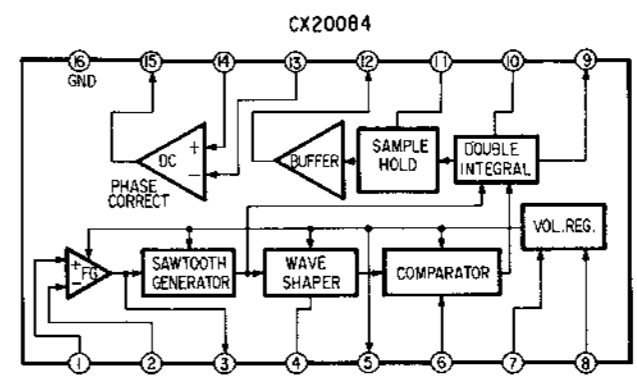

**SECTION 5
EXPLODED VIEWS AND PARTS LIST**

NOTE:

- The mechanical parts with no reference number in the exploded views are not supplied.
- Items marked " * " are not stocked since they are seldom required for routine service. Some delay should be anticipated when ordering these items.
- The construction parts of an assembled part are indicated with a collation number in the remark column.

(1)

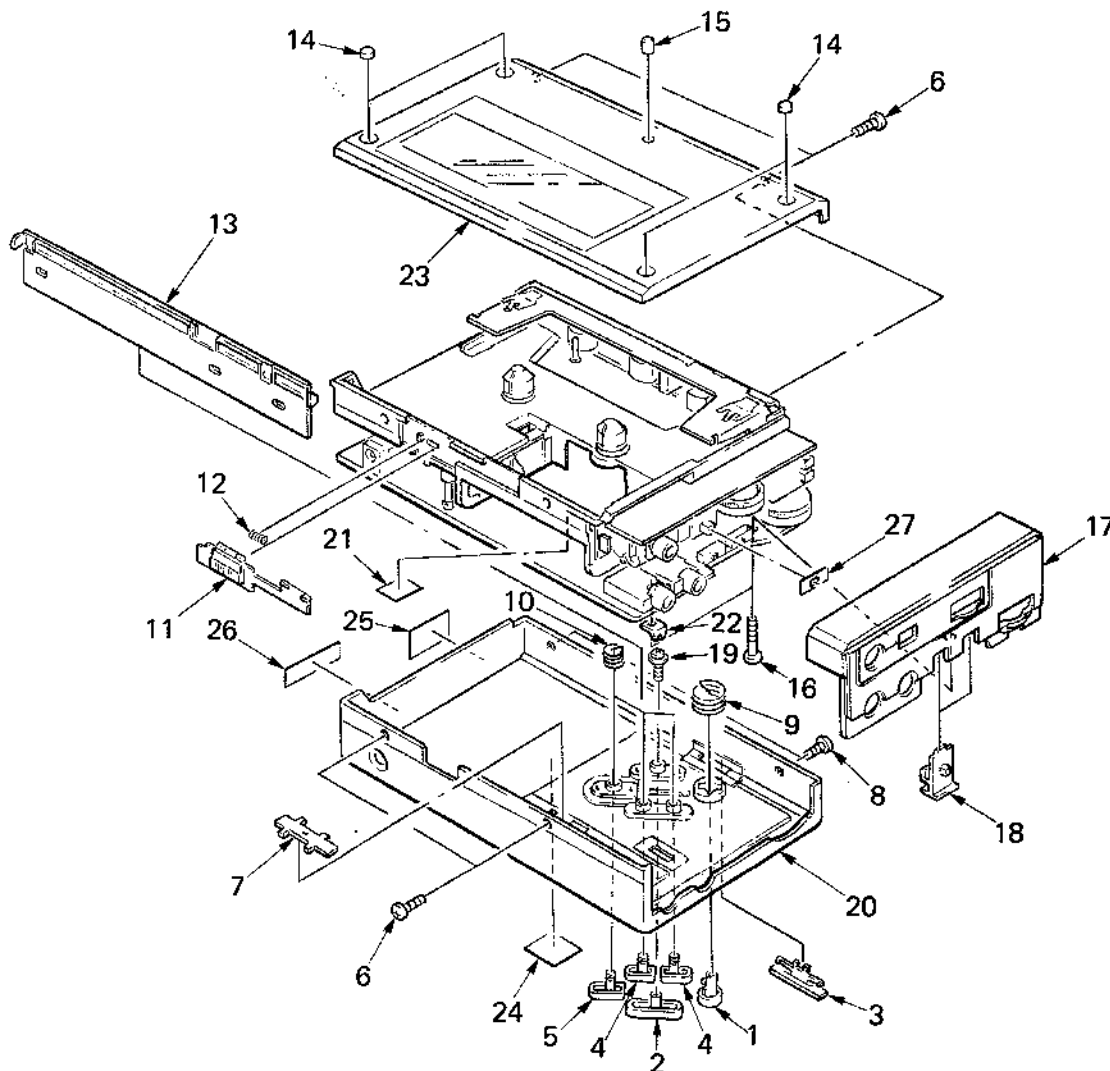

No.	Part No.	Description	Remarks	No.	Part No.	Description	Remarks
1	3-331-618-01	BUTTON, REC		16	3-318-203-41	SCREW (Ø1.7X12), TAPPING	
2	3-331-617-01	BUTTON, STOP		17	3-331-623-01	PANEL, SIDE	
3	3-331-619-01	KNOB, PAUSE		18	3-331-612-01	KNOB, SELECT	
4	A-3051-039-A	BUTTON BLOCK ASSY, FR		19	3-318-201-01	SCREW (B) (1.4X3), TAPPING	
5	A-3051-040-A	BUTTON BLOCK ASSY, PLAY		20	X-3331-614-1	(US, Canadian, AEP, ET)...PANEL ASSY, CONTROL	
6	3-703-816-42	SCREW (M1.4X2.5), SPECIAL HEAD			X-3331-617-1	(FRANCE, UK).....PANEL ASSY, CONTROL	
7	3-331-621-01	KNOB, METER SELECTION		21	3-831-441-XX	SPACER	
8	3-703-816-12	SCREW (M1.4X4.0), SPECIAL HEAD		22	*3-331-679-01	PLATE (B), GROUND	
9	3-331-608-01	SPRING, COMPRESSION		23	X-3331-615-1	PANEL ASSY, CASSETTE	
10	3-331-609-01	SPRING, COMPRESSION		24	3-703-710-01	STICKER, SONY SYMBOL (12)	
11	3-331-626-01	KNOB, OPEN		25	3-318-522-11	LABEL, DOLBY	
12	3-310-947-00	SPRING, COMPRESSION		26	3-331-660-01	(US, Canadian, AEP, ET)...LABEL, MODEL NUMBER	
13	3-331-613-01	ORNAMENT, FRONT			3-331-693-01	(FRANCE, UK).....LABEL, MODEL NUMBER	
14	3-331-603-01	FOOT		27	9-911-863-XX	PLATE, BLIND	
15	3-578-232-21	ORNAMENT, ADJUSTMENT HOLE					

(2)

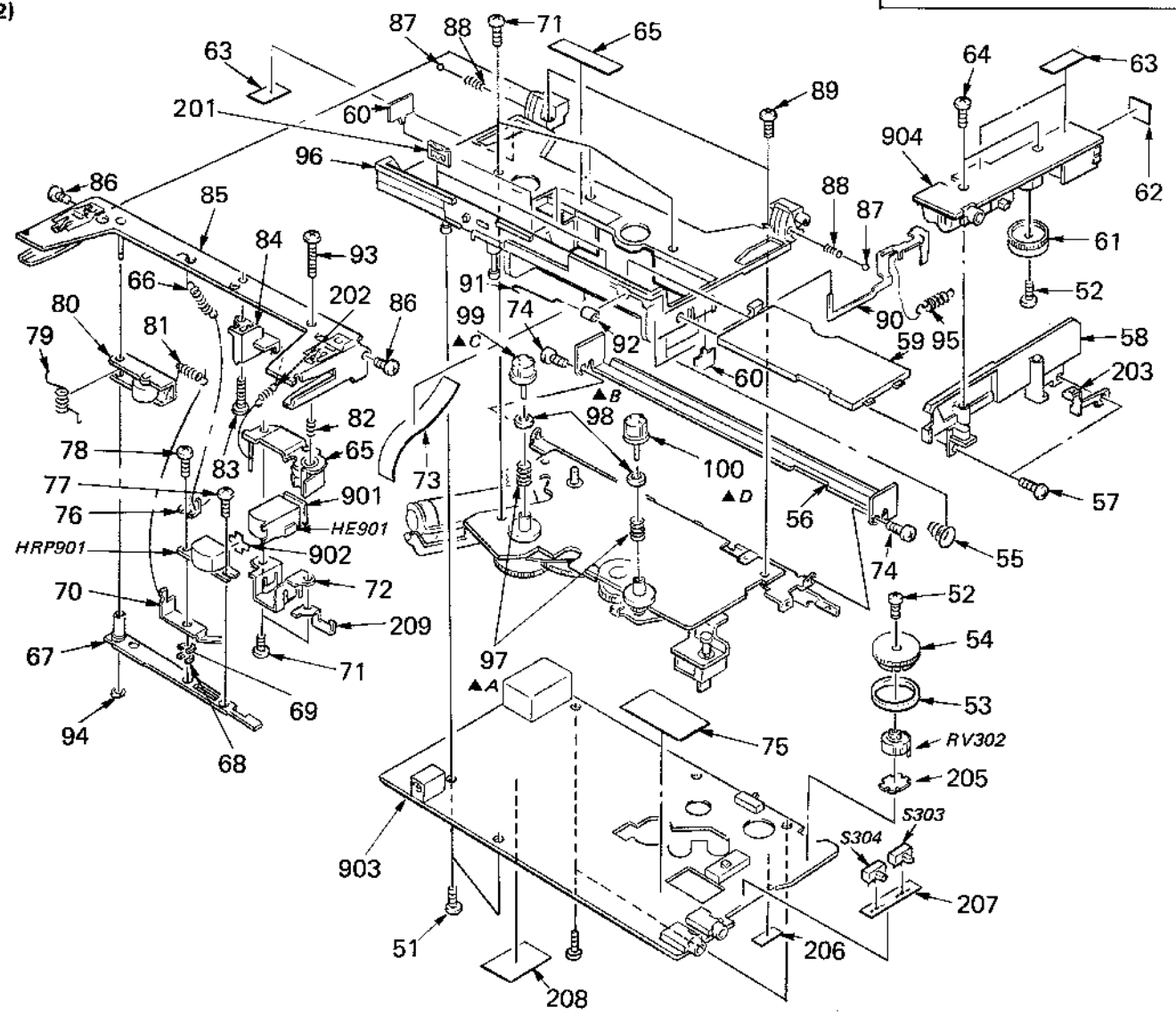

No.	Part No.	Description	Remarks	No.	Part No.	Description	Remarks
51	7-627-850-57	SCREW, PRECISION +P 1.4X3.5		85	*X-3331-611-1	HOLDER ASSY	
52	7-627-551-77	SCREW, PRECISION +P 1.4X4 TYPE1		86	7-627-551-28	SCREW, PRECISION +P 1.4X2.5	
53	3-331-602-01	ORNAMENT, KNOB, VOL		87	7-671-112-01	STEEL, BALL	
54	3-331-611-01	KNOB, VOL		88	3-578-127-00	SP RING, COMPRESSION	
55	3-578-236-00	SPRING		89	7-627-851-27	SCREW, PRECISION +P 1.4X5	
56	3-331-614-01	RETAINER, CASSETTE PANEL		90	3-305-430-00	LEVER, ERASING PROTECTION	
57	7-627-850-68	SCREW, PRECISION +P 1.4X4		91	3-305-415-00	SPRING	
58	*3-331-624-01	CHASSIS (B)		92	3-305-403-00	CLAW, ERASING PROTECTION	
59	3-578-115-00	LID, BATTERY CASE		93	3-331-659-01	SCREW (M1.7X12), 0 (P1)	
60	3-578-109-00	CONTACT		94	3-578-254-00	RING, RETAINING, E1.2	
61	X-3331-601-1	KNOB ASSY (REC), VOLUME		95	3-305-523-00	SPRING, TENSION	
62	*3-572-862-00	SPACER		96	X-3331-613-1	CHASSIS ASSY	
63	3-831-441-11	CUSHION (B)		97	3-578-123-00	SPRING, COMPRESSION	
64	3-318-203-61	SCREW (B1.7X4), TAPPING		98	3-310-958-00	WASHER	
65	*X-3331-609-1	CHASSIS ASSY, ERASE HEAD		99	X-3578-115-0	CLAW ASSY, REEL	
66	3-545-588-00	SPRING, TENSION		100	X-3578-126-0	CLAW ASSY, REEL	
67	X-3331-603-1	CHASSIS ASSY, HEAD		201	3-578-141-00	SPRING	
68	3-578-138-11	SEAM (t=0.1)		202	3-331-658-01	SPRING, TENSION	
69	3-578-138-01	SEAM (t=0.2)		203	*3-331-680-01	PLATE (C), GROUND	
70	3-578-181-00	SPRING		204	3-578-101-00	PLATE, ORNAMENTAL	
71	7-627-850-48	+P 1.4X1.6		205	3-331-677-01	SPACER, VOL	
72	*3-331-647-01	RETAINER, ERASE HEAD		206	3-327-119-01	SHEET (A), INSULATING	
73	9-911-816-01	CLOTH, DRAWER, BATTERY		207	*3-331-675-01	SPACER	
74	3-331-665-01	SCREW (M1.4), STEP		208	3-327-119-01	SHEET (B), INSULATING	
75	3-331-664-01	PLATE, BLIND		209	*3-331-654-01	CLAMP, LEAD	
76	3-310-971-01	HOOK, SPRING		901	1-617-799-11	PC BOARD, ERASE HEAD	
77	7-627-554-17	SCREW, PRECISION +P 2X3.5		902	1-617-800-11	PC BOARD, RECORD/PLAYBACK HEAD	
78	7-627-553-37	SCREW, PRECISION +P 2X3		903	A-3060-030-A	MOUNTED PCB, MAIN	
79	3-578-146-00	SPRING		904	A-3089-151-A	PC BOARD ASSY, REC	
80	X-3578-137-0	PINCH ROLLER ASSY		HE901	8-825-724-70	ERASE HEAD EP201-36G	
81	3-578-220-00	SPRING, TENSION		HRP901	1-543-296-11	HEAD	
82	3-331-631-01	SPRING, COMPRESSION		RV302	1-230-165-00	RES, VAR, CARBON 10K/10K	
83	7-627-553-98	SCREW, PRECISION +P 2X8		S303	1-553-510-00	SWITCH, SLIDE	
84	3-331-649-01	TABLE, HEAD		S304	1-553-510-00	SWITCH, SLIDE	

(3)

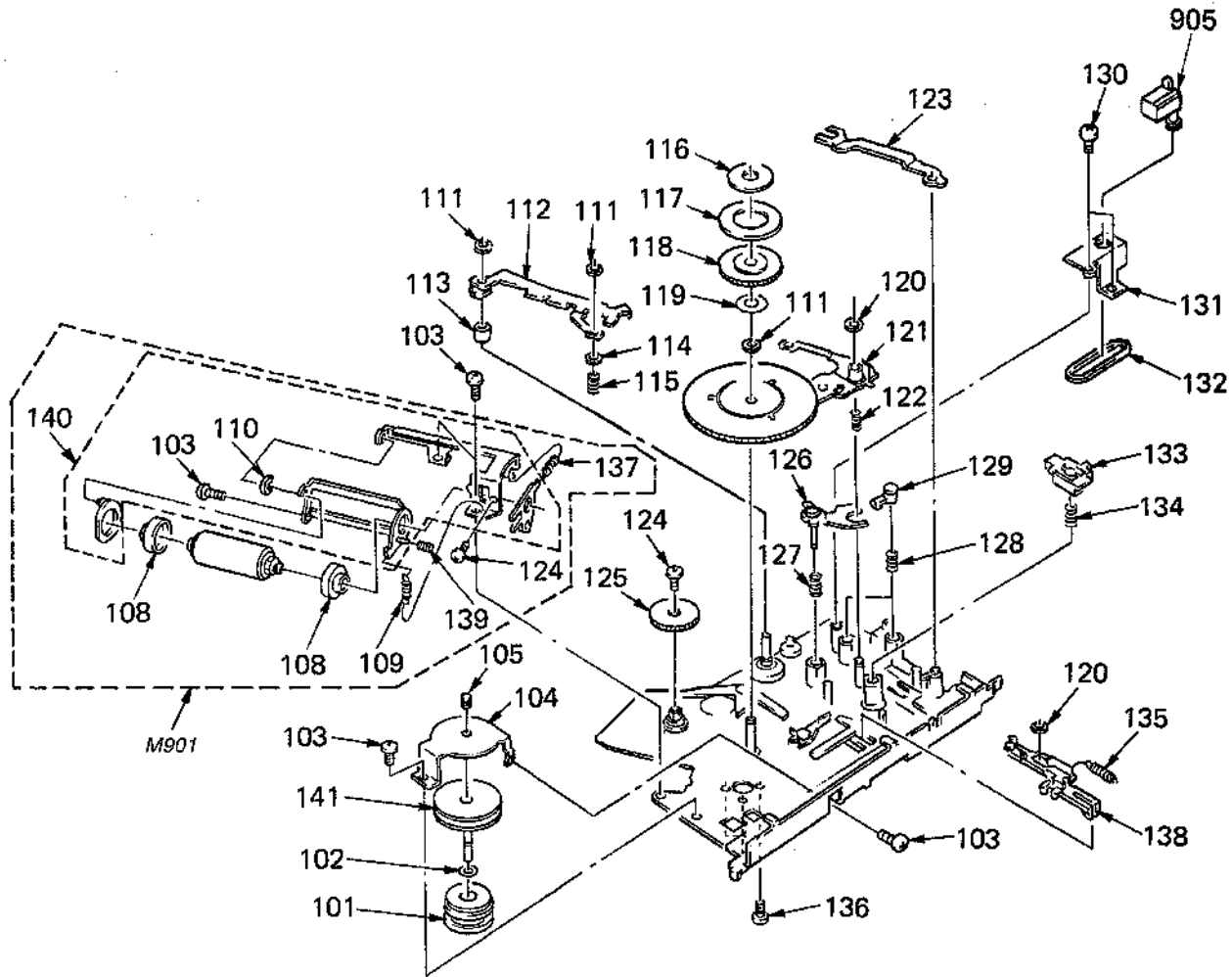

Ref. No.	Part No.	Description	Remark	Ref. No.	Part No.	Description	Remark
101	X-3310-907-0	STATOR ASSY		* 123	3-305-425-00	ARM (B), REC	
102	3-701-438-01	WASHER		124	7-627-851-17	SCREW, PRECISION +P 1.4X4.5	
103	7-627-850-79	SCREW, PRECISION +P 1.4X1.8 TYPE3		125	3-310-914-00	GEAR, FWD	
104	3-310-930-00	PLATE, THRUST		126	X-3331-604-1	LEVER ASSY, FWD	
105	3-547-625-00	SCREW, THRUST ADJUST		127	3-578-249-00	SPRING, COMPRESSION (FWD BUTTON)	
108	3-310-939-00	RUBBER, VIBRATION PROOF		128	3-578-278-00	SPRING, COMPRESSION	
109	3-310-948-00	SPRING, TENSION		129	X-3331-605-1	LEVER ASSY, FR	
110	7-624-102-04	STOP RING 1.5, TYPE-E		130	7-627-850-18	SCREW, PRECISION +P 1.4X2.5	
111	3-578-224-00	WASHER		* 131	3-331-638-01	BRACKET, COUNTER	
* 112	X-3331-618-1	ARM (A) ASSY, REC		132	3-561-645-00	BELT, C	
113	3-305-497-00	COLLAR, REC ARM		133	X-3331-606-1	LEVER ASSY, STOP	
114	3-701-436-11	WASHER, 1.6		134	3-578-121-00	SPRING, COMPRESSION	
115	3-305-423-00	SPRING, COMPRESSION		135	3-570-589-00	SPRING, TENSION	
116	3-310-916-00	PLATE (B), HYSTERESIS		136	7-627-451-87	SCREW, PRECISION +K 1.4X2.2	
117	3-310-920-00	PLATE (C), HYSTERESIS		137	3-310-921-00	SPRING, COMPRESSION	
118	3-310-915-11	GEAR (B), DRIVING		138	X-3331-602-1	LEVER ASSY, FWD SW	
119	3-701-444-11	WASHER, 6		139	3-310-993-01	SPRING, COMPRESSION	
120	3-578-224-11	WASHER		140	X-3310-932-1	BRACKET ASSY, MOTOR	
121	X-3578-142-0	LEVER (A) ASSY, DRIVING		905	1-548-566-00	COUNTER	
122	3-578-199-00	SPRING, COMPRESSION		M901	X-3363-087-1	MOTOR BLOCK ASSY	

(4)

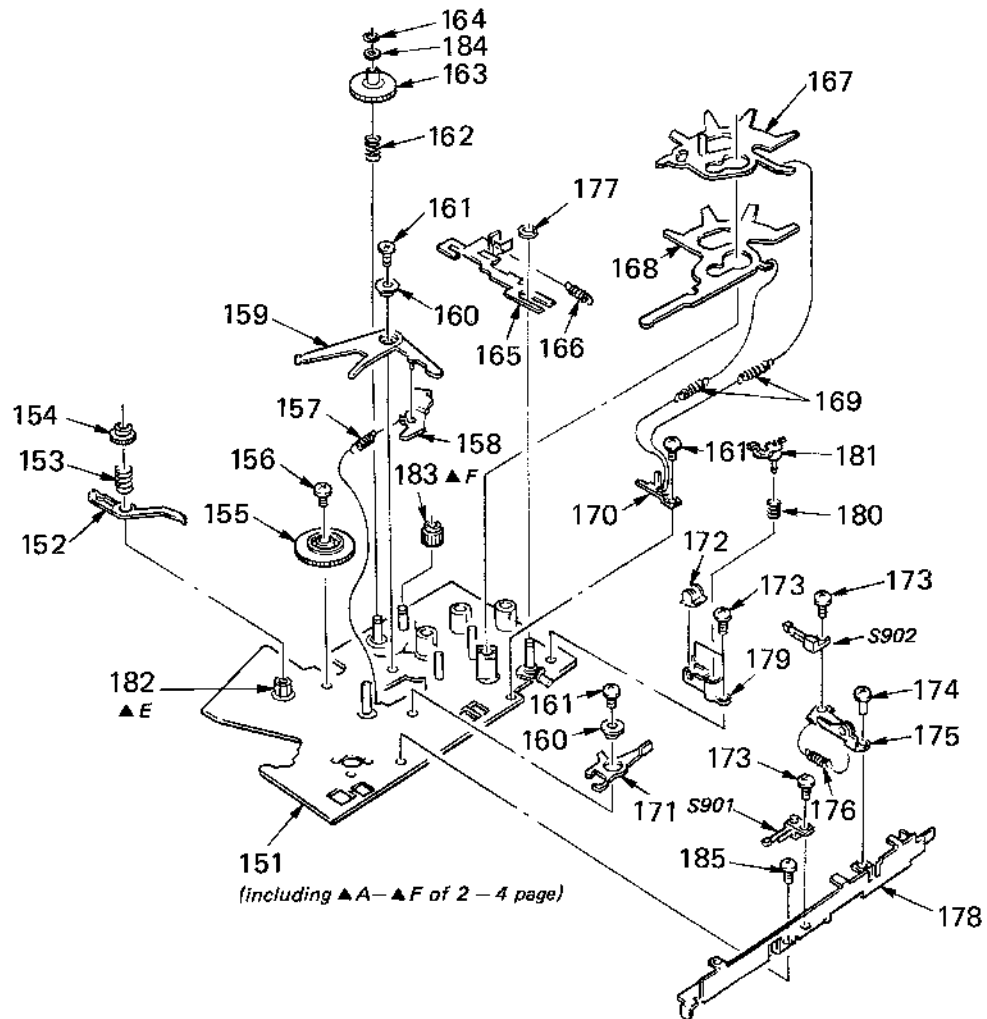

(including ▲A-▲F of 2-4 page)

No.	Part No.	Description	Remarks	No.	Part No.	Description	Remarks
151	X-3331-612-1	CHASSIS ASSY, SUB		170	*3-331-629-01	HOOK, SPRING	
152	3-578-154-00	LEVER, DETECTION		171	3-578-183-00	LEVER, RETURN, S	
153	3-578-124-00	SPRING, COMPRESSION		172	3-305-402-00	LEVER (B), REC	
154	3-578-244-01	GEAR, FF		173	7-627-850-18	SCREW, PRECISION +P 1.4X2.5	
155	3-578-178-00	GEAR, SHUT-OFF		174	7-627-850-48	+P 1.4X1.6	
156	3-578-214-00	SHAFT, GEAR, SHUT-OFF		175	X-3331-602-1	LEVER ASSY, FWD SW	
157	3-578-126-00	SPRING, TENSION		176	3-570-589-00	SPRING, TENSION	
158	3-305-509-00	LEVER (A), SHUT-OFF		177	7-624-102-04	STOP RING 1.5, TYPE -E	
159	3-578-157-00	LEVER (B), SHUT-OFF		178	*X-3331-610-1	PLATE ASSY, SIDE	
160	*3-578-149-00	SHAFT, LEVER (A), SHUT-OFF		179	3-305-444-00	GUIDE, REC BUTTON	
161	3-578-267-00	SCREW (+P1.4X1.6), PRECISION		180	3-305-432-00	SPRING, COMPRESSION	
162	3-578-221-00	SPRING, COMPRESSION		181	X-3305-409-0	GUIDE ASSY, REC BUTTON	
163	3-578-162-00	GEAR, REW		182	3-578-151-00	SHAFT, GEAR, FWD	
164	7-624-101-01	RING, RETAINING E-1.2		183	3-331-641-01	GEAR, S	
165	X-3331-608-1	LEVER (A) ASSY, REC		184	3-701-436-01	WASHER, 1.6	
166	3-669-411-01	SPRING, TENSION		185	3-703-816-02	SCREW (M1.4X2.0), SPECIAL HEAD	
167	X-3578-114-0	PLATE ASSY, LOCK		S901	1-553-682-00	SWITCH, LEAF	
168	3-578-136-00	LEVER, SWITCH		S902	1-553-226-00	SWITCH, LEAF	
169	3-578-277-00	SPRING, TENSION					

SECTION 6
ELECTRICAL PARTS LIST

NOTE:

Items marked " * " are not stocked since they are seldom required for routine service. Some delay should be anticipated when ordering these items.
If there are two or more same circuits in a set such as a stereophonic machine, only typical circuit parts may be indicated and capacitors and resistors in other same circuits may be omitted.

CAPACITORS:
MF:µF, PF:µµF.
RESISTORS
All resistors are in ohms.
F : nonflammable
COILS
MMH : mH, UH : µH

SEMICONDUCTORS
In each case, U : µ, for example:
UA...: µA..., UPA...: µPA..., UPC...: µPC,
UPD...: µPD...

ELECTRICAL PARTS

Ref.No.	Part No.	Description			
901	1-617-799-11	PC BOARD, ERASE HEAD			
902	1-617-800-11	PC BOARD, RECORD/PLAYBACK HEAD			
903	A-3060-030-A	MOUNTED PCB, MAIN			
904	A-3089-151-A	PC BOARD ASSY, REC			
905	1-548-566-00	COUNTER			
C101	1-124-499-11	ELECT 1MF	20%	50V	
C102	1-163-141-00	CERAMIC CHIP 0.001MF	10%	50V	
C103	1-163-141-00	CERAMIC CHIP 0.001MF	10%	50V	
C104	1-135-083-00	TANTAL. CHIP 0.47MF	20%	25V	
C105	1-135-091-00	TANTAL. CHIP 1MF	20%	16V	
C106	1-163-141-00	CERAMIC CHIP 0.001MF	10%	50V	
C107	1-135-096-21	TANTAL. CHIP 4.7MF	20%	10V	
C108	1-163-019-00	CERAMIC CHIP 0.0068MF	10%	50V	
C109	1-163-137-00	CERAMIC CHIP 680PF	10%	50V	
C110	1-163-055-00	CERAMIC CHIP 0.0047MF	10%	50V	
C111	1-135-104-00	TANTAL. CHIP 10MF	10%	4V	
C112	1-135-103-00	TANTAL. CHIP 3.3MF	20%	4V	
C113	1-163-810-00	CERAMIC CHIP 0.03MF	10%	25V	
C114	1-163-023-00	CERAMIC CHIP 0.015MF	5%	50V	
C115	1-163-177-00	CERAMIC CHIP 68PF	5%	50V	
C116	1-163-021-00	CERAMIC CHIP 0.01MF	5%	50V	
C117	1-163-075-00	CERAMIC CHIP 0.047MF	10%	25V	
C118	1-135-083-00	TANTAL. CHIP 0.47MF	10%	25V	
C119	1-135-073-00	TANTAL. CHIP 0.33MF	10%	35V	
C120	1-135-091-00	TANTAL. CHIP 1MF	20%	16V	
C121	1-135-091-00	TANTAL. CHIP 1MF	20%	16V	
C122	1-163-141-00	CERAMIC CHIP 0.001MF	10%	50V	
C123	1-163-081-00	CERAMIC CHIP 0.22MF		25V	
C124	1-123-827-00	ELECT 220MF	20%	4V	
C125	1-135-091-00	TANTAL. CHIP 1MF	20%	16V	
C126	1-135-091-00	TANTAL. CHIP 1MF	20%	16V	
C127	1-107-042-00	MICA 2.2PF	0.5PF	500V	
C128	1-107-323-00	MICA 15P/18P/22P/27P			
C129	1-107-208-00	MICA 18PF	5%	500V	
C130	1-163-988-11	CERAMIC CHIP 180PF	5%	100V	
C131	1-135-091-00	TANTAL. CHIP 1MF	20%	16V	
C132	1-135-070-00	TANTAL. CHIP 0.1MF	20%	35V	
C133	1-163-137-00	CERAMIC CHIP 680PF	10%	50V	
C134	1-135-096-21	TANTAL. CHIP 4.7MF	20%	10V	
C135	1-135-096-21	TANTAL. CHIP 4.7MF	20%	10V	
C136	1-135-099-00	TANTAL. CHIP 2.2MF	20%	6.3V	
C137	1-163-129-00	CERAMIC CHIP 560PF	10%	50V	
C138	1-163-021-00	CERAMIC CHIP 0.01MF	5%	50V	
C139	1-163-023-00	CERAMIC CHIP 0.015MF	5%	50V	
C140	1-163-021-00	CERAMIC CHIP 0.01MF	5%	50V	

ELECTRICAL PARTS

Ref.No.	Part No.	Description			
C141	1-163-075-00	CERAMIC CHIP 0.047MF	10%	25V	
C142	1-163-137-00	CERAMIC CHIP 680PF	10%	50V	
C143	1-163-109-00	CERAMIC CHIP 47PF	5%	50V	
C144	1-163-109-00	CERAMIC CHIP 47PF	5%	50V	
C201	1-124-499-11	ELECT 1MF	20%	50V	
C202	1-163-141-00	CERAMIC CHIP 0.001MF	10%	50V	
C203	1-163-141-00	CERAMIC CHIP 0.001MF	10%	50V	
C204	1-135-083-00	TANTAL. CHIP 0.47MF	20%	25V	
C205	1-135-091-00	TANTAL. CHIP 1MF	20%	16V	
C206	1-163-141-00	CERAMIC CHIP 0.001MF	10%	50V	
C207	1-135-096-21	TANTAL. CHIP 4.7MF	20%	10V	
C208	1-163-019-00	CERAMIC CHIP 0.0068MF	10%	50V	
C209	1-163-137-00	CERAMIC CHIP 680PF	10%	50V	
C210	1-163-055-00	CERAMIC CHIP 0.0047MF	10%	50V	
C211	1-135-104-00	TANTAL. CHIP 10MF	10%	4V	
C212	1-135-103-00	TANTAL. CHIP 3.3MF	20%	4V	
C213	1-163-810-00	CERAMIC CHIP 0.03MF	10%	25V	
C214	1-163-023-00	CERAMIC CHIP 0.015MF	5%	50V	
C215	1-163-177-00	CERAMIC CHIP 68PF	5%	50V	
C216	1-163-021-00	CERAMIC CHIP 0.01MF	5%	50V	
C217	1-163-075-00	CERAMIC CHIP 0.047MF	10%	25V	
C218	1-135-083-00	TANTAL. CHIP 0.47MF	10%	25V	
C219	1-135-073-00	TANTAL. CHIP 0.33MF	10%	35V	
C220	1-135-091-00	TANTAL. CHIP 1MF	20%	16V	
C221	1-135-091-00	TANTAL. CHIP 1MF	20%	16V	
C222	1-163-141-00	CERAMIC CHIP 0.001MF	10%	50V	
C223	1-163-081-00	CERAMIC CHIP 0.22MF		25V	
C224	1-123-827-00	ELECT 220MF	20%	4V	
C225	1-135-091-00	TANTAL. CHIP 1MF	20%	16V	
C226	1-135-091-00	TANTAL. CHIP 1MF	20%	16V	
C227	1-107-042-00	MICA 2.2PF	0.5PF	500V	
C228	1-107-323-00	MICA 15P/18P/22P/27P			
C229	1-107-208-00	MICA 18PF	5%	500V	
C230	1-163-988-11	CERAMIC CHIP 180PF	5%	100V	
C231	1-135-091-00	TANTAL. CHIP 1MF	20%	16V	
C232	1-135-070-00	TANTAL. CHIP 0.1MF	20%	35V	
C233	1-163-137-00	CERAMIC CHIP 680PF	10%	50V	
C234	1-135-096-21	TANTAL. CHIP 4.7MF	20%	10V	
C235	1-135-096-21	TANTAL. CHIP 4.7MF	20%	10V	
C236	1-135-099-00	TANTAL. CHIP 2.2MF	20%	6.3V	
C237	1-163-129-00	CERAMIC CHIP 560PF	10%	50V	
C238	1-163-021-00	CERAMIC CHIP 0.01MF	5%	50V	
C239	1-163-023-00	CERAMIC CHIP 0.015MF	5%	50V	
C240	1-163-021-00	CERAMIC CHIP 0.01MF	5%	50V	
C241	1-163-075-00	CERAMIC CHIP 0.047MF	10%	25V	

ELECTRICAL PARTS

Ref.No.	Part No.	Description			
C242	1-163-137-00	CERAMIC CHIP 680PF	10%	50V	
C243	1-163-109-00	CERAMIC CHIP 47PF	5%	50V	
C244	1-163-109-00	CERAMIC CHIP 47PF	5%	50V	
C245	1-163-109-00	CERAMIC CHIP 47PF	5%	50V	
C301	1-123-306-00	ELECT 47MF	20%	10V	
C302	1-124-433-00	ELECT 100MF	20%	4V	
C303	1-123-618-00	ELECT 22MF	20%	6.3V	
C304	1-124-233-00	ELECT 10MF	20%	16V	
C305	1-124-233-00	ELECT 10MF	20%	16V	
C306	1-124-220-00	ELECT 33MF	20%	4V	
C307	1-123-827-00	ELECT 220MF	20%	4V	
C308	1-135-104-00	TANTAL. CHIP 10MF	20%	4V	
C309	1-124-222-00	ELECT 22MF	20%	6.3V	
C310	1-124-220-00	ELECT 33MF	20%	4V	
C311	1-163-021-00	CERAMIC CHIP 0.01MF	10%	50V	
C312	1-135-103-00	TANTAL. CHIP 3.3MF	20%	4V	
C313	1-135-091-00	TANTAL. CHIP 1MF	20%	16V	
C314	1-124-229-00	ELECT 33MF	20%	6.3V	
C315	1-135-104-00	TANTAL. CHIP 10MF	20%	4V	
C316	1-135-091-00	TANTAL. CHIP 1MF	20%	16V	
C317	1-123-827-00	ELECT 220MF	20%	4V	
C318	1-123-307-00	ELECT 100MF	20%	10V	
C319	1-130-896-00	FILM 0.0082MF	5%	400V	
C320	1-131-361-00	TANTALUM 2.2MF	20%	16V	
C321	1-130-479-00	MYLAR 0.0047MF	5%	50V	
C322	1-163-013-00	CERAMIC CHIP 0.0022MF	10%	50V	
C323	1-124-229-00	ELECT 33MF	20%	6.3V	
C324	1-124-225-00	ELECT 100MF	20%	6.3V	
C325	1-135-103-00	TANTAL. CHIP 3.3MF	20%	4V	
C326	1-135-101-21	TANTAL. CHIP 22MF	20%	4V	
C327	1-135-096-21	TANTAL. CHIP 4.7MF	20%	10V	
C328	1-124-430-00	ELECT 22MF	20%	4V	
C329	1-163-141-00	CERAMIC CHIP 0.001MF	10%	50V	
C330	1-163-141-00	CERAMIC CHIP 0.001MF	10%	50V	
C331	1-163-141-00	CERAMIC CHIP 0.001MF	10%	50V	
C332	1-163-137-00	CERAMIC CHIP 680PF	10%	50V	
C601	1-163-038-00	CERAMIC CHIP 0.1MF		25V	
C602	1-163-023-00	CERAMIC CHIP 0.015MF	10%	50V	
C603	1-135-070-00	TANTAL. CHIP 0.1MF	20%	35V	
C604	1-163-012-00	CERAMIC CHIP 0.0018MF	10%	50V	
C605	1-130-483-00	MYLAR 0.01MF	5%	50V	
C606	1-135-104-00	TANTAL. CHIP 10MF	20%	4V	
C607	1-130-489-00	MYLAR 0.033MF	5%	50V	
C608	1-163-021-00	CERAMIC CHIP 0.01MF	10%	50V	
C609	1-163-810-00	CERAMIC CHIP 0.03MF	10%	25V	
C610	1-163-075-00	CERAMIC CHIP 0.047MF	10%	25V	
C611	1-135-091-00	TANTAL. CHIP 1MF	10%	16V	
C612	1-163-021-00	CERAMIC CHIP 0.01MF	10%	50V	
C613	1-135-103-00	TANTAL. CHIP 3.3MF	20%	4V	
CN301	1-507-723-00	JACK, EXTENTION POWER			
CP101	1-235-317-11	FILTER, LOW PASS			
CP201	1-235-317-11	FILTER, LOW PASS			
CP301	1-464-576-11	CONVERTER UNIT, DC-DC			
HE901	8-825-724-70	ERASE HEAD EP201-36G			
HRP901	1-543-296-11	HEAD			

ELECTRICAL PARTS

Ref.No.	Part No.	Description			
D301	8-719-100-05	DIODE 1S2837-T1			
D302	8-719-105-91	DIODE RD5.6M-T2B2			
D303	8-719-912-24	DIODE GL-1PR1			
D304	8-719-912-24	DIODE GL-1PR1			
D305	8-719-912-24	DIODE GL-1PR1			
D306	8-719-912-24	DIODE GL-1PR1			
D307	8-719-912-24	DIODE GL-1PR1			
D308	8-719-912-24	DIODE GL-1PR1			
D309	8-719-100-05	DIODE 1S2837			
IC301	8-759-910-18	IC BA3304F			
IC302	8-752-030-38	IC CXA1058M			
IC303	8-759-200-95	IC TA7688F			
IC304	8-759-700-43	IC NJM4558M			
IC305	8-759-700-43	IC NJM4558M			
IC306	8-759-909-40	IC CX10043			
IC601	8-759-909-45	IC CX20084			
J301	1-507-917-21	JACK, STEREO (MIC/LINE IN)			
J303	1-507-917-00	JACK, STEREO (PHONES)			
JR301	1-216-295-00	METAL CHIP	0	5%	1/10W
JR302	1-216-295-00	METAL CHIP	0	5%	1/10W
JR303	1-216-295-00	METAL CHIP	0	5%	1/10W
JR304	1-216-296-00	METAL CHIP	0	5%	1/8W
JR305	1-216-295-00	METAL CHIP	0	5%	1/10W
JR308	1-216-296-00	METAL CHIP	0	5%	1/8W
JR309	1-216-295-00	METAL CHIP	0	5%	1/10W
JR310	1-216-296-00	METAL CHIP	0	5%	1/8W
JR311	1-216-296-00	METAL CHIP	0	5%	1/8W
JR312	1-216-295-00	METAL CHIP	0	5%	1/10W
L101	1-408-682-00	MICRO INDUCTOR 10MMH			
L102	1-408-930-00	MICRO INDUCTOR 33MMH			
L201	1-408-682-00	MICRO INDUCTOR 10MMH			
L202	1-408-930-00	MICRO INDUCTOR 33MMH			
M901	X-3331-616-1	MOTOR			
Q101	8-729-100-66	TRANSISTOR 2SC1623			
Q102	8-729-100-66	TRANSISTOR 2SC1623			
Q103	8-729-900-98	TRANSISTOR DTC143TK			
Q104	8-729-900-98	TRANSISTOR DTC143TK			
Q105	8-729-900-98	TRANSISTOR DTC143TK			
Q106	8-729-900-98	TRANSISTOR DTC143TK			
Q107	8-729-900-98	TRANSISTOR DTC143TK			
Q108	8-729-900-98	TRANSISTOR DTC143TK			
Q201	8-729-100-66	TRANSISTOR 2SC1623			
Q202	8-729-100-66	TRANSISTOR 2SC1623			
Q203	8-729-900-98	TRANSISTOR DTC143TK			
Q204	8-729-900-98	TRANSISTOR DTC143TK			
Q205	8-729-900-98	TRANSISTOR DTC143TK			
Q206	8-729-900-98	TRANSISTOR DTC143TK			
Q207	8-729-900-98	TRANSISTOR DTC143TK			
Q208	8-729-900-98	TRANSISTOR DTC143TK			
Q301	8-729-100-66	TRANSISTOR 2SC1623			
Q302	8-729-100-76	TRANSISTOR 2SA812			
Q303	8-729-901-46	TRANSISTOR DTA114YK			
Q304	8-729-100-66	TRANSISTOR 2SC1623			
Q305	8-729-100-76	TRANSISTOR 2SA812			
Q306	8-729-100-66	TRANSISTOR 2SC1623			
Q307	8-729-100-66	TRANSISTOR 2SC1623			
Q308	8-729-900-52	TRANSISTOR DTC114YK			

ELECTRICAL PARTS

Ref.No.	Part No.	Description				
Q309	8-729-900-98	TRANSISTOR	DTC143TK			
Q310	8-729-900-98	TRANSISTOR	DTC143TK			
Q311	8-729-199-92	TRANSISTOR	2SD999			
Q312	8-729-159-64	TRANSISTOR	2SD596			
Q313	8-729-100-66	TRANSISTOR	2SC1623			
Q314	8-729-100-66	TRANSISTOR	2SC1623			
Q315	8-729-100-76	TRANSISTOR	2SA812			
Q316	8-729-900-98	TRANSISTOR	DTC143TK			
Q317	8-729-900-98	TRANSISTOR	DTC143TK			
Q318	8-729-900-98	TRANSISTOR	DTC143TK			
Q319	8-729-100-76	TRANSISTOR	2SA812			
Q320	8-729-100-66	TRANSISTOR	2SC1623			
Q321	8-729-100-66	TRANSISTOR	2SC1623			
Q322	8-729-100-66	TRANSISTOR	2SC1623			
Q323	8-729-901-46	TRANSISTOR	DTA114YK			
Q601	8-729-101-07	TRANSISTOR	2SB798			
Q602	8-729-100-66	TRANSISTOR	2SC1623			
Q603	8-729-100-66	TRANSISTOR	2SC1623			
Q604	8-729-100-76	TRANSISTOR	2SA812			
R101	1-216-093-00	METAL CHIP	68K	5%	1/10W	
R103	1-216-113-00	METAL CHIP	470K	5%	1/10W	
R104	1-216-063-00	METAL CHIP	3.9K	5%	1/10W	
R105	1-216-023-00	METAL CHIP	82	5%	1/10W	
R107	1-216-111-00	METAL CHIP	390K	5%	1/10W	
R108	1-216-101-00	METAL CHIP	150K	5%	1/10W	
R109	1-216-029-00	METAL CHIP	150	5%	1/10W	
R110	1-216-049-00	METAL CHIP	1K	5%	1/10W	
R111	1-216-083-00	METAL CHIP	27K	5%	1/10W	
R112	1-216-115-00	METAL CHIP	560K	5%	1/10W	
R113	1-216-084-00	METAL CHIP	30K	5%	1/10W	
R114	1-216-101-00	METAL CHIP	150K	5%	1/10W	
R115	1-216-055-00	METAL CHIP	1.8K	5%	1/10W	
R116	1-216-055-00	METAL CHIP	1.8K	5%	1/10W	
R117	1-216-097-00	METAL CHIP	100K	5%	1/10W	
R118	1-216-073-00	METAL CHIP	10K	5%	1/10W	
R119	1-216-053-00	METAL CHIP	1.5K	5%	1/10W	
R120	1-216-077-00	METAL CHIP	15K	5%	1/10W	
R121	1-216-077-00	METAL CHIP	15K	5%	1/10W	
R122	1-216-068-00	METAL CHIP	6.2K	5%	1/10W	
R123	1-216-073-00	METAL CHIP	10K	5%	1/10W	
R124	1-216-046-00	METAL CHIP	750	5%	1/10W	
R125	1-216-097-00	METAL CHIP	100K	5%	1/10W	
R126	1-216-053-00	METAL CHIP	1.5K	5%	1/10W	
R127	1-216-140-00	METAL CHIP	3.9	5%	1/8W	
R128	1-216-053-00	METAL CHIP	1.5K	5%	1/10W	
R129	1-216-037-00	METAL CHIP	330	5%	1/10W	
R130	1-216-089-00	METAL CHIP	47K	5%	1/10W	
R131	1-216-095-00	METAL CHIP	82K	5%	1/10W	
R132	1-216-073-00	METAL CHIP	10K	5%	1/10W	
R133	1-216-057-00	METAL CHIP	2.2K	5%	1/10W	
R134	1-216-089-00	METAL CHIP	47K	5%	1/10W	
R135	1-216-206-00	METAL CHIP	2.2K	5%	1/8W	
R136	1-216-091-00	METAL CHIP	56K	5%	1/10W	
R137	1-216-089-00	METAL CHIP	47K	5%	1/10W	
R138	1-216-105-00	METAL CHIP	220K	5%	1/10W	
R139	1-216-069-00	METAL CHIP	6.8K	5%	1/10W	
R140	1-216-097-00	METAL CHIP	100K	5%	1/10W	
R141	1-216-063-00	METAL CHIP	3.9K	5%	1/10W	

ELECTRICAL PARTS

Ref.No.	Part No.	Description				
R142	1-216-033-00	METAL CHIP	220	5%	1/10W	
R143	1-216-033-00	METAL CHIP	220	5%	1/10W	
R144	1-216-079-00	METAL CHIP	18K	5%	1/10W	
R145	1-216-077-00	METAL CHIP	15K	5%	1/10W	
R146	1-216-232-00	METAL CHIP	27K	5%	1/8W	
R147	1-216-073-00	METAL CHIP	10K	5%	1/10W	
R148	1-216-069-00	METAL CHIP	6.8K	5%	1/10W	
R201	1-216-093-00	METAL CHIP	68K	5%	1/10W	
R203	1-216-113-00	METAL CHIP	470K	5%	1/10W	
R204	1-216-063-00	METAL CHIP	3.9K	5%	1/10W	
R205	1-216-023-00	METAL CHIP	82	5%	1/10W	
R207	1-216-111-00	METAL CHIP	390K	5%	1/10W	
R208	1-216-101-00	METAL CHIP	150K	5%	1/10W	
R209	1-216-029-00	METAL CHIP	150	5%	1/10W	
R210	1-216-049-00	METAL CHIP	1K	5%	1/10W	
R211	1-216-083-00	METAL CHIP	27K	5%	1/10W	
R212	1-216-115-00	METAL CHIP	560K	5%	1/10W	
R213	1-216-084-00	METAL CHIP	30K	5%	1/10W	
R214	1-216-101-00	METAL CHIP	150K	5%	1/10W	
R215	1-216-055-00	METAL CHIP	1.8K	5%	1/10W	
R216	1-216-055-00	METAL CHIP	1.8K	5%	1/10W	
R217	1-216-097-00	METAL CHIP	100K	5%	1/10W	
R218	1-216-073-00	METAL CHIP	10K	5%	1/10W	
R219	1-216-053-00	METAL CHIP	1.5K	5%	1/10W	
R220	1-216-077-00	METAL CHIP	15K	5%	1/10W	
R221	1-216-077-00	METAL CHIP	15K	5%	1/10W	
R222	1-216-068-00	METAL CHIP	6.2K	5%	1/10W	
R223	1-216-073-00	METAL CHIP	10K	5%	1/10W	
R224	1-216-046-00	METAL CHIP	750	5%	1/10W	
R225	1-216-097-00	METAL CHIP	100K	5%	1/10W	
R226	1-216-053-00	METAL CHIP	1.5K	5%	1/10W	
R227	1-216-140-00	METAL CHIP	3.9	5%	1/8W	
R228	1-216-053-00	METAL CHIP	1.5K	5%	1/10W	
R229	1-216-037-00	METAL CHIP	330	5%	1/10W	
R230	1-216-089-00	METAL CHIP	47K	5%	1/10W	
R231	1-216-095-00	METAL CHIP	82K	5%	1/10W	
R232	1-216-073-00	METAL CHIP	10K	5%	1/10W	
R233	1-216-057-00	METAL CHIP	2.2K	5%	1/10W	
R234	1-216-089-00	METAL CHIP	47K	5%	1/10W	
R235	1-216-206-00	METAL CHIP	2.2K	5%	1/8W	
R236	1-216-091-00	METAL CHIP	56K	5%	1/10W	
R237	1-216-089-00	METAL CHIP	47K	5%	1/10W	
R238	1-216-105-00	METAL CHIP	220K	5%	1/10W	
R239	1-216-069-00	METAL CHIP	6.8K	5%	1/10W	
R240	1-216-097-00	METAL CHIP	100K	5%	1/10W	
R241	1-216-063-00	METAL CHIP	3.9K	5%	1/10W	
R242	1-216-033-00	METAL CHIP	220	5%	1/10W	
R243	1-216-033-00	METAL CHIP	220	5%	1/10W	
R244	1-216-079-00	METAL CHIP	18K	5%	1/10W	
R245	1-216-077-00	METAL CHIP	15K	5%	1/10W	
R246	1-216-232-00	METAL CHIP	27K	5%	1/8W	
R247	1-216-073-00	METAL CHIP	10K	5%	1/10W	
R248	1-216-069-00	METAL CHIP	6.8K	5%	1/10W	
R301	1-216-049-00	METAL CHIP	1K	5%	1/10W	
R302	1-216-053-00	METAL CHIP	1.5K	5%	1/10W	
R303	1-216-073-00	METAL CHIP	10K	5%	1/10W	
R304	1-216-049-00	METAL CHIP	1K	5%	1/10W	

ELECTRICAL PARTS

Ref.No.	Part No.	Description			
R305	1-216-073-00	METAL CHIP	10K	5%	1/10W
R306	1-216-093-00	METAL CHIP	68K	5%	1/10W
R307	1-216-224-00	METAL CHIP	12K	5%	1/8W
R308	1-216-077-00	METAL CHIP	15K	5%	1/10W
R309	1-216-075-00	METAL CHIP	12K	5%	1/10W
R310	1-216-073-00	METAL CHIP	10K	5%	1/10W
R311	1-216-097-00	METAL CHIP	100K	5%	1/10W
R312	1-216-089-00	METAL CHIP	47K	5%	1/10W
R313	1-216-097-00	METAL CHIP	100K	5%	1/10W
R314	1-216-097-00	METAL CHIP	100K	5%	1/10W
R315	1-216-109-00	METAL CHIP	330K	5%	1/10W
R316	1-216-113-00	METAL CHIP	470K	5%	1/10W
R317	1-216-089-00	METAL CHIP	47K	5%	1/10W
R318	1-216-039-00	METAL CHIP	390	5%	1/10W
R319	1-216-013-00	METAL CHIP	33	5%	1/10W
R320	1-216-089-00	METAL CHIP	47K	5%	1/10W
R321	1-216-065-00	METAL CHIP	4.7K	5%	1/10W
R322	1-216-055-00	METAL CHIP	1.8K	5%	1/10W
R323	1-216-055-00	METAL CHIP	1.8K	5%	1/10W
R324	1-216-105-00	METAL CHIP	220K	5%	1/10W
R325	1-216-077-00	METAL CHIP	15K	5%	1/10W
R326	1-216-075-00	METAL CHIP	12K	5%	1/10W
R327	1-216-097-00	METAL CHIP	100K	5%	1/10W
R328	1-216-089-00	METAL CHIP	47K	5%	1/10W
R329	1-216-061-00	METAL CHIP	3.3K	5%	1/10W
R330	1-216-097-00	METAL CHIP	100K	5%	1/10W
R331	1-216-031-00	METAL CHIP	180	5%	1/10W
R332	1-216-031-00	METAL CHIP	180	5%	1/10W
R333	1-216-031-00	METAL CHIP	180	5%	1/10W
R334	1-216-031-00	METAL CHIP	180	5%	1/10W
R335	1-216-031-00	METAL CHIP	180	5%	1/10W
R336	1-216-101-00	METAL CHIP	150K	5%	1/10W
R337	1-216-073-00	METAL CHIP	10K	5%	1/10W
R338	1-216-001-00	METAL CHIP	10	5%	1/10W
R339	1-216-089-00	METAL CHIP	47K	5%	1/10W
R340	1-216-049-00	METAL CHIP	1K	5%	1/10W
R343	1-216-049-00	METAL CHIP	1K	5%	1/10W
R344	1-216-097-00	METAL CHIP	100K	5%	1/10W
R601	1-216-058-00	METAL CHIP	2.4K	5%	1/10W
R602	1-216-093-00	METAL CHIP	68K	5%	1/10W
R603	1-216-093-00	METAL CHIP	68K	5%	1/10W
R604	1-216-095-00	METAL CHIP	82K	5%	1/10W
R605	1-216-061-00	METAL CHIP	3.3K	5%	1/10W
R606	1-216-097-00	METAL CHIP	100K	5%	1/10W
R607	1-216-105-00	METAL CHIP	220K	5%	1/10W
R608	1-216-129-00	METAL CHIP	2.2M	5%	1/10W
R609	1-216-073-00	METAL CHIP	10K	5%	1/10W
R610	1-216-089-00	METAL CHIP	47K	5%	1/10W
R611	1-216-037-00	METAL CHIP	330	5%	1/10W
R612	1-216-081-00	METAL CHIP	22K	5%	1/10W
R613	1-216-049-00	METAL CHIP	1K	5%	1/10W
RV101	1-237-101-11	RES, ADJ, METAL GLAZE	4.7K		
RV102	1-237-119-11	RES, ADJ, METAL GLAZE	22K		
RV201	1-237-101-11	RES, ADJ, METAL GLAZE	4.7K		
RV202	1-237-119-11	RES, ADJ, METAL GLAZE	22K		
RV301	1-237-102-11	RES, VAR, CARBON	10K/10K		
RV302	1-230-165-00	RES, VAR, CARBON	10K/10K		
RV601	1-230-901-11	RES, ADJ, METAL GLAZE	20K		

ELECTRICAL PARTS

Ref.No.	Part No.	Description
S301	1-554-575-00	SWITCH, SLIDE
S302	1-553-942-00	SWITCH, SLIDE
S303	1-553-510-00	SWITCH, SLIDE
S304	1-553-510-00	SWITCH, SLIDE
S305	1-570-113-11	SWITCH, SLIDE
S601	1-554-912-11	SWITCH, SLIDE
S901	1-553-682-00	SWITCH, LEAF
S902	1-553-226-00	SWITCH, LEAF
T301	1-433-244-00	TRANSFORMER, BIAS OSCILLATOR

ACCESSORY & PACKING MATERIAL

Part No.	Description
1-555-658-21	CORD, CONNECTION (RK-129)
1-557-132-00	(US, Canadian, AEP, FRANCE, UK)CORD, CONNECTION (PC-62)
3-331-670-01	(US).....INDIVIDUAL CARTON
3-331-671-01	(Canadian).....INDIVIDUAL CARTON
3-331-672-01	(AEP,UK,FRANCE)..INDIVIDUAL CARTON
3-331-669-01	(ET).....INDIVIDUAL CARTON
3-331-674-01	CUSHION
3-331-683-01	CASE, CARRYING
3-331-686-01	BELT, CARRYING
3-331-689-01	(US, Canadian, AEP, FRANCE, UK)..SPACER, HEADPHONE
3-331-694-01	(US, Canadian, AEP, FRANCE, UK)..SHEET, PROTECTION
3-527-213-00	LABEL, SERIAL NUMBER
3-570-631-51	BAG, POLYETHYLENE
3-570-631-61	BAG, POLYETHYLENE
*3-701-999-00	LABEL, SERIAL NUMBER
3-331-667-01	(ET).....SPACER
3-760-922-11	(AEP,UK).....MANUAL, INSTRUCTION
3-760-922-21	(US,Canadian)...MANUAL, INSTRUCTION
3-760-922-41	(FRANCE).....MANUAL, INSTRUCTION
3-795-748-21	(US)...SAFETY INSTRUCTIONS, HEADPHONE
8-810-077-90	(US, Canadian, AEP, FRANCE, UK)..MICROPHONE MCX-284
8-952-232-90	(US, Canadian, AEP, FRANCE, UK)..HEADPHONE MDR-W20L/B SET

