

WM-3060

SERVICE MANUAL

*US Model
Canadian Model
AEP Model
UK Model
E Model*

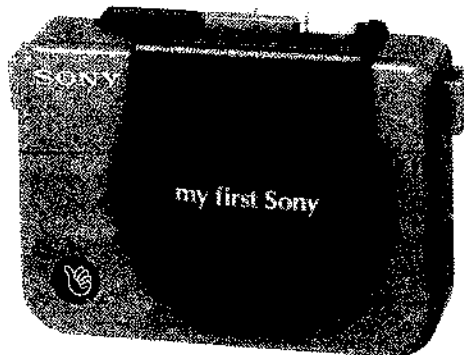

Model Name Using Similar Mechanism	WM-3000
Tape Transport Mechanism Type	MT-WM3060-04

SPECIFICATIONS

Tape track	Compact cassette stereo
Frequency response	40-15,000Hz
Power output	Speaker: 160mW Headphone: 15mW + 15mW load impedance 32ohms
Power requirements	3V DC, two size AA (IEC designation R6) batteries
Battery life	

Batteries	Continuous playback hours
Sony New Super SUM-3 (NS)	Approx.4
Sony alkaline AM3 (N)	Approx.8

For maximum performance we recommend the use of alkaline batteries.

Dimensions	Approx. 126 × 91 × 43mm (w/h/d) (4 7/8 × 3 5/8 × 1 5/8 inches) incl. projection parts and controls
Weight	Approx. 250g (8.8oz) incl. batteries, not incl. other accessories.
Accessories	Stereo headphones Shoulder belt

STEREO CASSETTE PLAYER
SONY®

SECTION 1 MECHANICAL ADJUSTMENTS

PRECAUTION

1. Clean the following parts with a denatured alcohol-moistened swab:

Playback head	rubber belts
capstan	idlers
pinch roller	
2. Demagnetize the playback head with a head demagnetizer.
3. Do not use a magnetized screwdriver for the adjustments.
4. After the adjustments, apply suitable locking compound to the parts adjusted.
5. The adjustments should be performed with the rated power supply voltage (3V) unless otherwise noted.

Torque Measurement

Torque	Meter Reading	Torque Meter
Forward	22-45g·cm (0.30-0.63oz·inch)	CQ-102C
Fast Forward	55-130g·cm (0.77-1.8oz·inch)	CQ-201B
Rewind	55-150g·cm (0.77-2.1oz·inch)	CQ-201B
Back Tension	0.5-2g·cm (0.007-0.028oz·inch)	CQ-102C

Tape Tension Measurement

Meter	Meter Reading
CQ-403A	more than 100g (3.57oz)

Test Tape

Type	Signal	Used for
WS-48A	3kHz, 0dB	Tape Speed Adjustment

SECTION 2 ELECTRICAL ADJUSTMENTS

Tape Speed Adjustment

Procedure :

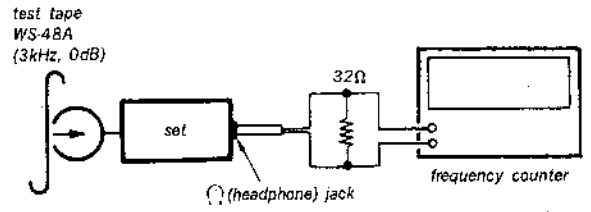

1. Play back WS-48A (Tape center portion) in FWD mode. Adjust the RV601 so that the frequency counter reads 3,000 Hz \pm 90Hz.
2. Confirm that the reading of frequency counter is within 1.5% from the reading in step 1.

Adjustment Location : main board

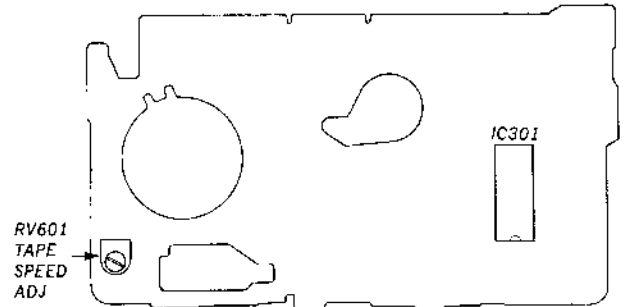

**SECTION 3
DIAGRAMS**

3-1. PRINTED WIRING BOARD

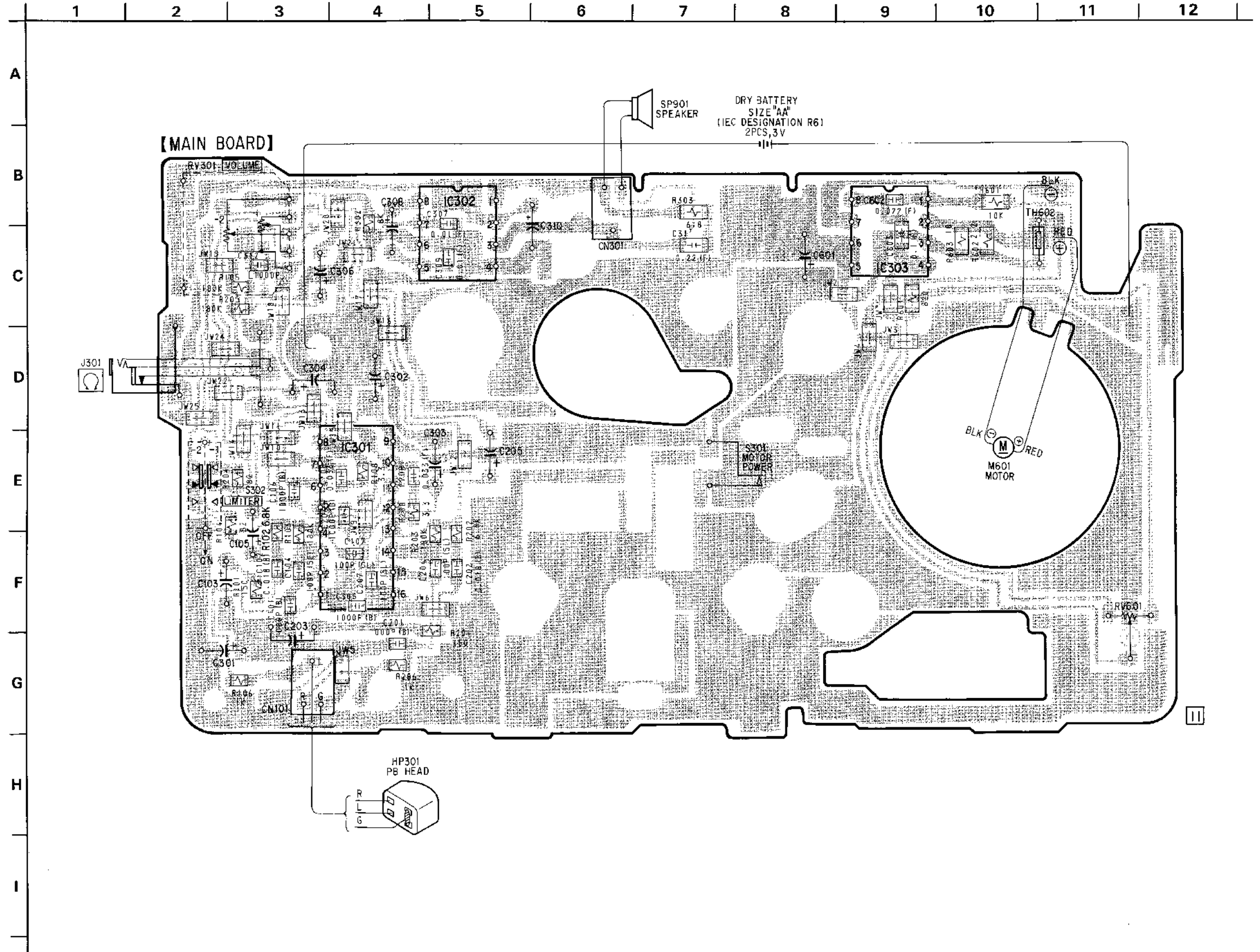

3-2. SCHEMATIC DIAGRAM

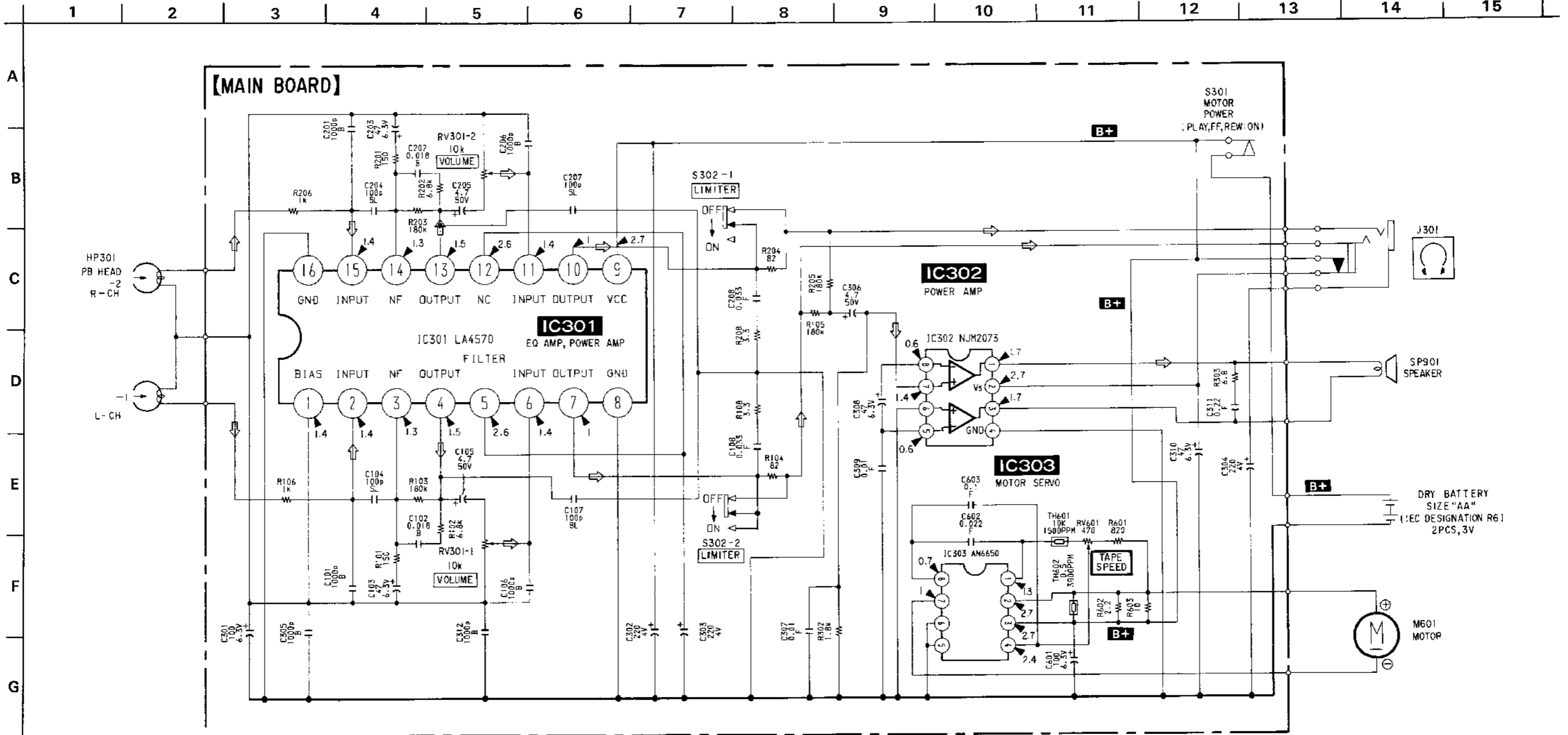

- Note:**
- All capacitors are in μF unless otherwise noted. pF: μmF 50WV or less are not indicated except for electrolytics and tantalums.
 - All resistors are in Ω and $\frac{1}{2}W$ or less unless otherwise specified.
 - \square : Adjust for repair.
 - Power voltage is dc 3V and fed with regulated dc power supply from battery terminal.
 - Voltage are dc with respect to ground under no-signal conditions.
 - Voltages are with a VOM (Input Impedance 10M Ω) Voltage variations may be noted due to normal production tolerances.
 - Signal path.
 - \Rightarrow : PB

• IC BLOCK Diagrams
IC301 LA4570

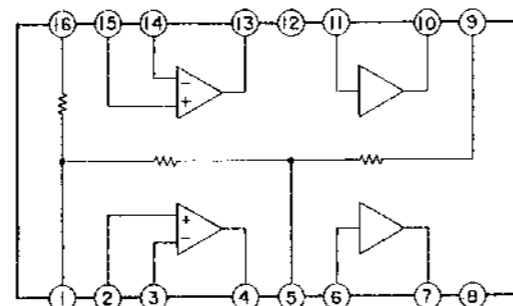

IC303 AN6650

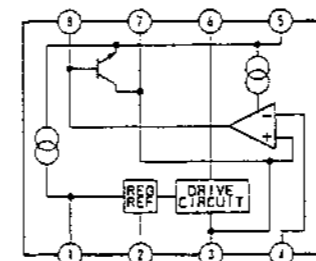

SECTION 4 EXPLODED VIEWS

NOTE:

The mechanical parts with no reference number in the exploded views are not supplied.

The construction parts of an assembled part are indicated with a collation number in the remark column.

Items marked "*" are not stocked since they are seldom required for routine service. Some delay should be anticipated when ordering these items.

Due to standardization, parts with part number suffix -XX and -X may be different from the parts specified in the components used on the set.

- Color Indication of Appearance Parts
Example:

(RED) ... KNOB, BALANCE (WHITE)



Cabinet's Color

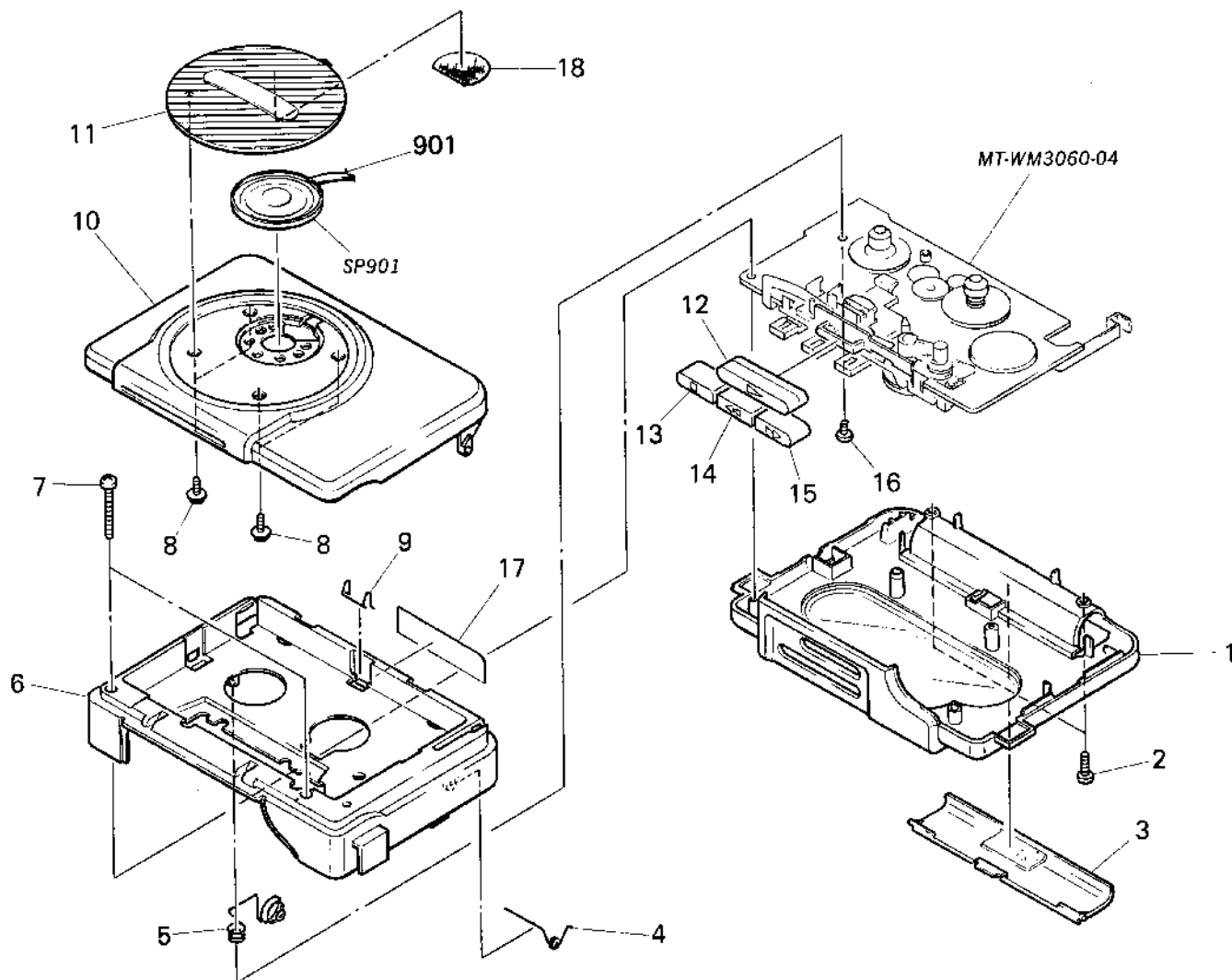

Parts' Color

4-1. CABINET SECTION

Ref.No	Part No.	Description	Remark
1	X-3355-901-1	CABINET (REAR) ASSY	
2	3-335-640-21	SCREW (M2X8)	
3	3-355-906-01	LID, BATTERY CASE	
4	3-342-903-01	SPRING	
5	3-355-903-01	SPRING	
6	3-355-910-01	(US, Canadian, AEP, Italian) ... CABINET (FRONT)	
6	3-355-910-21	(UK, French, E) ... CABINET (FRONT)	
7	3-335-640-51	SCREW (M2X16)	
8	3-321-041-01	SCREW (M1.7X3.5), TAPPING	
9	3-355-902-01	SPRING	
10	X-3355-903-1	HOLDER ASSY, CASSETTE	
11	3-355-904-01	GRILLE, SP	

Ref.No	Part No.	Description	Remark
12	3-346-512-21	BUTTON (PLAY)	
13	3-346-515-21	BUTTON (STOP)	
14	3-346-514-21	BUTTON (REW)	
15	3-346-513-21	BUTTON (FF)	
16	3-338-355-01	SCREW (M2), TAPPING	
17	*3-355-924-01	(E) ... LABEL, MODEL NUMBER	
17	*3-355-929-01	(UK) ... LABEL, MODEL NUMBER	
17	*3-355-930-01	(French) ... LABEL, MODEL NUMBER	
18	3-355-927-01	NET, SP	
901	1-632-874-11	PC BOARD, SP FLEXIBE	
SP901	1-544-186-11	SPEAKER	

4-2. MECHANISM DECK SECTION
(MT-WM3060-04)

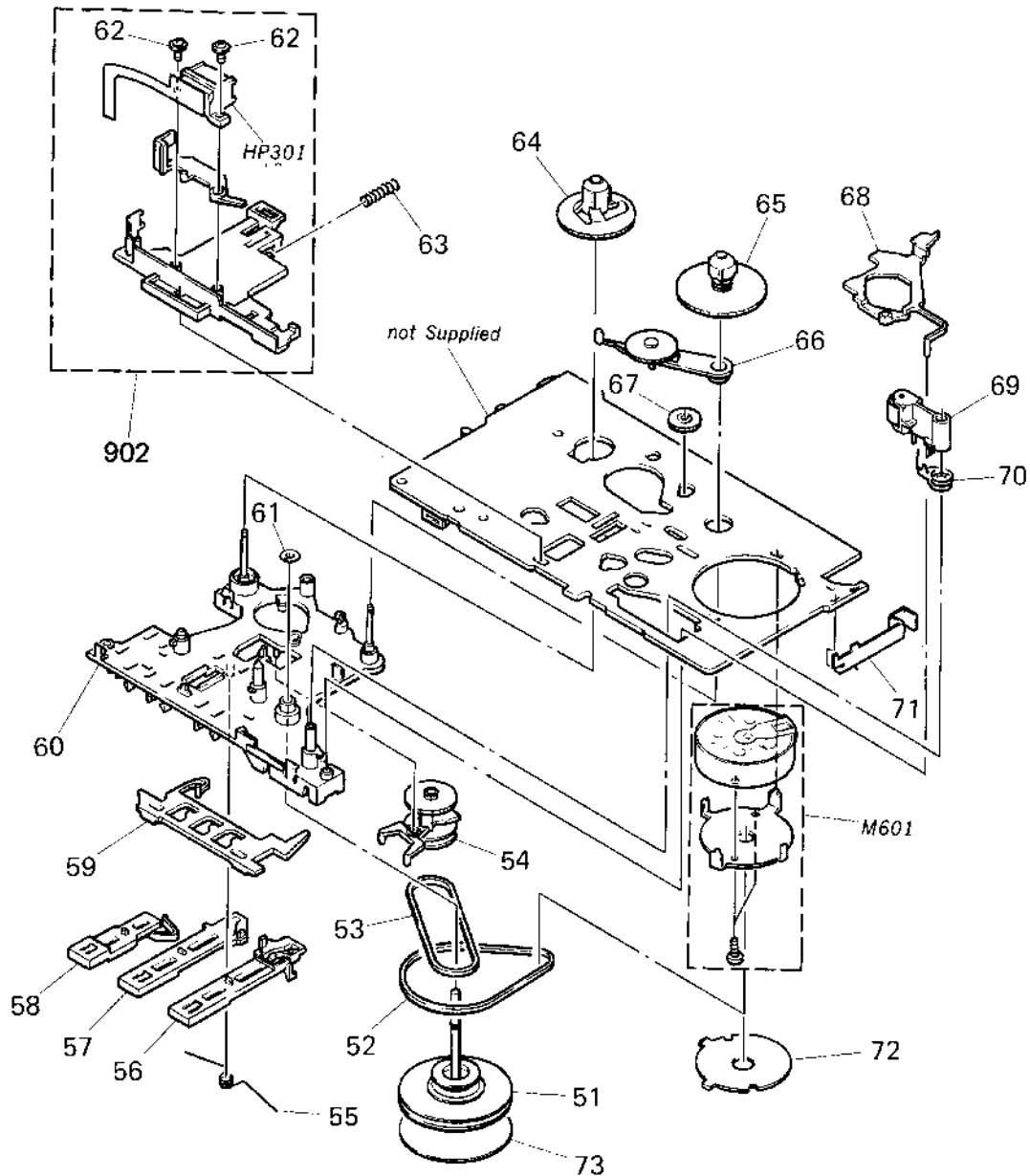

Ref.No	Part No.	Description	Remark	Ref.No	Part No.	Description	Remark
51	X-3346-746-1	WHEEL ASSY, CAPSTAN		64	3-346-525-01	GEAR (S REEL)	
52	3-351-544-01	RING (CARSTAN)		65	X-3346-502-1	TABLE ASSY, T REEL	
53	3-352-727-01	RING (MIDWAY)		66	X-3346-504-1	GEAR ASSY, PLAY	
54	X-3346-598-1	GEAR ASSY, MIDWAY		67	3-334-089-01	GEAR, FF	
55	3-346-539-01	SPRING (FR)		68	3-346-523-01	LEVER (SHUT-OFF)	
56	3-346-526-11	LEVER (FF)		69	X-3334-005-1	PINCH ROLLER ASSY	
57	3-346-527-11	LEVER (REW)		70	3-335-608-01	SPRING	
58	3-346-528-01	LEVER (STOP)		71	3-355-928-01	TERMINAL BOARD, BATTERY	
59	3-346-522-11	PLATE, LOCK		72	3-355-926-01	LABEL, MOTOR	
60	X-3346-536-1	BASE ASSY, GUIDE		73	3-355-925-01	LABEL, FLYWHEEL	
61	3-343-358-01	RING, RETAINING		902	A-3108-292-A	PC BOARD ASSY, HEAD	
62	3-348-448-01	SCREW (HEAD)		HP301	1-543-634-11	HEAD, MAGNETIC (PLAYBACK)	
63	3-335-605-01	SPRING, COMPRESSION		M601	1-541-650-21	MOTOR	

SECTION 5 ELECTRICAL PARTS LIST

NOTE:

- Due to standardization, replacements in the parts list may be different from the parts specified in the diagrams or the components used on the set.
- Items marked "★" are not stocked since they are seldom required for routine service. Some delay should be anticipated when ordering these items.
- If there are two or more same circuits in a set such as a stereophonic machine, only typical circuit parts may be indicated and capacitors and resistors in other same circuits may be omitted.

CAPACITORS:

MF: μ F, PF: μ μ F.

RESISTORS

- All resistors are in ohms.
- F: nonflammable

COILS

- MMH: mH, UH: μ H

SEMICONDUCTORS

In each case, U: μ , for example:
 UA...: μ A..., UPA...: μ PA...,
 UPC...: μ PC, UPD...: μ PD...

Ref.No	Part No.	Description
901	1-632-874-11	PC BOARD, SP FLEXIBE
902	A-3108-292-A	PC BOARD ASSY. HEAD
CAPACITOR		
C101	1-163-009-11	CERAMIC CHIP 0.001MF 10% 50V
C102	1-163-024-00	CERAMIC CHIP 0.018MF 10% 50V
C103	1-126-154-11	ELECT 47MF 20% 6.3V
C104	1-163-117-00	CERAMIC CHIP 100PF 5% 50V
C105	1-126-163-11	ELECT 4.7MF 20% 50V
C106	1-163-009-11	CERAMIC CHIP 0.001MF 10% 50V
C107	1-163-117-00	CERAMIC CHIP 100PF 5% 50V
C108	1-163-034-00	CERAMIC CHIP 0.033MF 50V
C201	1-163-009-11	CERAMIC CHIP 0.001MF 10% 50V
C202	1-163-024-00	CERAMIC CHIP 0.018MF 10% 50V
C203	1-126-154-11	ELECT 47MF 20% 6.3V
C204	1-163-117-00	CERAMIC CHIP 100PF 5% 50V
C205	1-126-163-11	ELECT 4.7MF 20% 50V
C206	1-163-009-11	CERAMIC CHIP 0.001MF 10% 50V
C207	1-163-117-00	CERAMIC CHIP 100PF 5% 50V
C208	1-163-034-00	CERAMIC CHIP 0.033MF 50V
C301	1-126-177-11	ELECT 100MF 20% 6.3V
C302	1-124-635-00	ELECT 220MF 20% 4V
C303	1-124-635-00	ELECT 220MF 20% 4V
C304	1-124-635-00	ELECT 220MF 20% 4V
C305	1-163-009-11	CERAMIC CHIP 0.001MF 10% 50V
C306	1-126-163-11	ELECT 4.7MF 20% 50V
C307	1-164-232-11	CERAMIC CHIP 0.01MF 50V
C308	1-126-154-11	ELECT 47MF 20% 6.3V
C309	1-164-232-11	CERAMIC CHIP 0.01MF 50V
C310	1-126-154-11	ELECT 47MF 20% 6.3V
C311	1-163-081-00	CERAMIC CHIP 0.22MF 25V
C312	1-163-009-11	CERAMIC CHIP 0.001MF 10% 50V
C601	1-126-177-11	ELECT 100MF 20% 6.3V
C602	1-163-033-00	CERAMIC CHIP 0.022MF 50V
C603	1-163-077-00	CERAMIC CHIP 0.1MF 50V
CN101	*1-565-288-11	HOUSING, CONNECTOR 3P
CN301	*1-565-288-11	HOUSING, CONNECTOR 3P
HP301	1-543-634-11	HEAD, MAGNETIC (PLAYBACK)
IC301	8-759-802-85	IC LA4570
IC302	8-759-701-54	IC NJM2073D
IC303	8-759-403-83	IC AN6650
J301	1-568-748-11	JACK (HEADPHONES)
JW1	1-216-296-00	METAL GLAZE 0 5% 1/8W
JW2	1-216-296-00	METAL GLAZE 0 5% 1/8W
JW3	1-216-296-00	METAL GLAZE 0 5% 1/8W
JW4	1-216-296-00	METAL GLAZE 0 5% 1/8W
JW5	1-216-296-00	METAL GLAZE 0 5% 1/8W
JW6	1-216-296-00	METAL GLAZE 0 5% 1/8W
JW9	1-216-296-00	METAL GLAZE 0 5% 1/8W
JW10	1-216-296-00	METAL GLAZE 0 5% 1/8W
JW11	1-216-296-00	METAL GLAZE 0 5% 1/8W
JW12	1-216-296-00	METAL GLAZE 0 5% 1/8W

Ref.No	Part No.	Description
JW13	1-216-296-00	METAL GLAZE 0 5% 1/8W
JW14	1-216-296-00	METAL GLAZE 0 5% 1/8W
JW15	1-216-296-00	METAL GLAZE 0 5% 1/8W
JW16	1-216-296-00	METAL GLAZE 0 5% 1/8W
JW17	1-216-296-00	METAL GLAZE 0 5% 1/8W
JW18	1-216-296-00	METAL GLAZE 0 5% 1/8W
JW19	1-216-296-00	METAL GLAZE 0 5% 1/8W
JW20	1-216-296-00	METAL GLAZE 0 5% 1/8W
JW21	1-216-296-00	METAL GLAZE 0 5% 1/8W
JW22	1-216-296-00	METAL GLAZE 0 5% 1/8W
JW24	1-216-296-00	METAL GLAZE 0 5% 1/8W
JW25	1-216-296-00	METAL GLAZE 0 5% 1/8W
M601	1-541-650-21	MOTOR

RESISTOR

R101	1-216-029-00	METAL GLAZE 150 5% 1/10W
R102	1-216-069-00	METAL GLAZE 6.8K 5% 1/10W
R103	1-216-103-00	METAL GLAZE 180K 5% 1/10W
R104	1-216-023-00	METAL GLAZE 82 5% 1/10W
R105	1-216-103-00	METAL GLAZE 180K 5% 1/10W
R106	1-216-049-00	METAL GLAZE 1K 5% 1/10W
R108	1-216-304-11	METAL GLAZE 3.3 5% 1/10W
R201	1-216-029-00	METAL GLAZE 150 5% 1/10W
R202	1-216-069-00	METAL GLAZE 6.8K 5% 1/10W
R203	1-216-103-00	METAL GLAZE 180K 5% 1/10W
R204	1-216-023-00	METAL GLAZE 82 5% 1/10W
R205	1-216-103-00	METAL GLAZE 180K 5% 1/10W
R206	1-216-049-00	METAL GLAZE 1K 5% 1/10W
R208	1-216-304-11	METAL GLAZE 3.3 5% 1/10W
R302	1-216-055-00	METAL GLAZE 1.8K 5% 1/10W
R303	1-216-146-00	METAL GLAZE 6.8 5% 1/8W
R601	1-216-196-00	METAL GLAZE 820 5% 1/8W
R602	1-216-134-00	METAL GLAZE 2.2 5% 1/8W
R603	1-216-150-00	METAL GLAZE 10 5% 1/8W

RV301	1-238-072-11	RES, VAR, CARBON 10K/10K (VOLUME)
RV601	1-238-596-11	RES, ADJ, CARBON 470

S301	1-571-621-21	SWITCH, LEAF (MOTOR POWER)
S302	1-571-478-11	SWITCH, SLIDE (LIMITER)

SP901	1-544-186-11	SPEAKER
-------	--------------	---------

TH601	1-808-664-21	THERMISTOR, POSITIVE
TH602	1-807-489-41	THERMISTOR (POSITIVE)

ACCESSORIES & PACKING MATERIAL

3-342-910-01	BELT, SHOULDER
*3-355-912-01	CUSHION (UPPER)
*3-355-913-01	CUSHION (LOWER)
*3-355-916-01	(US) ... INDIVIDUAL CARTON
*3-355-917-01	(Canadian) ... INDIVIDUAL CARTON
*3-355-918-01	(AEP, Italian, French) ... INDIVIDUAL CARTON
*3-355-919-01	(UK) ... INDIVIDUAL CARTON
*3-355-921-01	(E) ... INDIVIDUAL CARTON
3-750-828-11	(EXCEPT FOR US) ... MANUAL, INSTRUCTION
3-750-828-41	(AEP, Italian) ... MANUAL, INSTRUCTION
8-952-313-92	HEADPHONE MDR-005L/R SET

