

TV-500UET

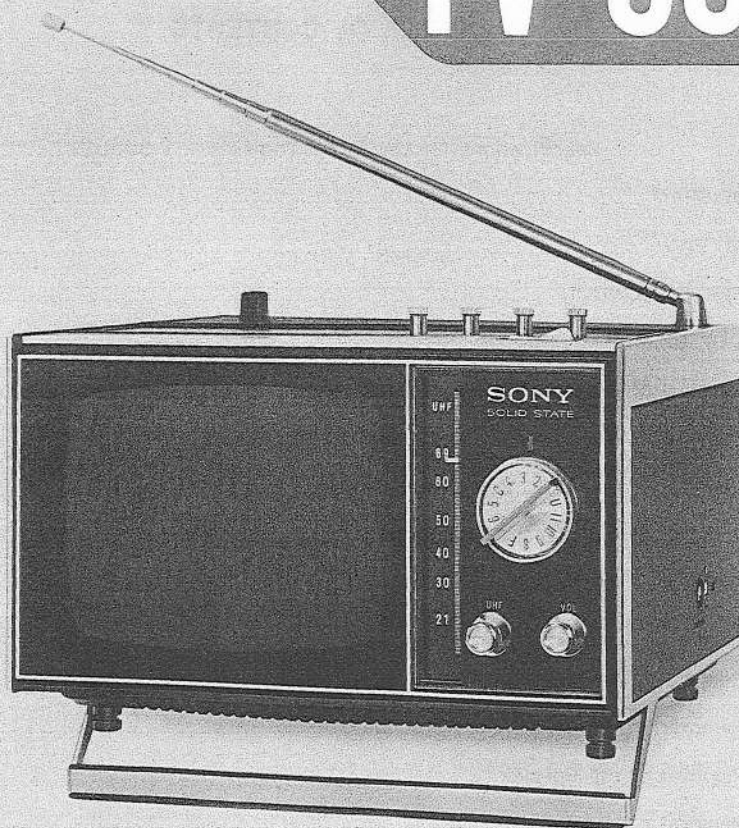

Specifications

Picture Tube:	5", 70° Deflection, Aluminized Screen Direct Heating Cathode
Transistor:	23 (15 Silicon 8 Germanium)
Diode:	16 (Including 4 Selenium)
Channel Coverage:	Western European VHF E2~E11 Italian VHF A~H Western European UHF E21~E69
Tuner:	Disc Turret Type for VHF Band and Continuous Tuning Type for UHF Band
Maximum Sensitivity:	VHF 5 μ V (10Vpp at Picture Tube Cathode) UHF 5 μ V (10Vpp at Picture Tube Cathode)
IF Circuit:	3 Stages with 4 Stagger Tuned Elements Video IF 38.90 MHz, Sound IF 33.4 MHz, Band Width 3.1 MHz
Sound System:	5.5 MHz Intercarrier System Power Output Stage; OTL System, 300 mW Speaker 2-5/8" x 4", 40 ohm Voice Coil
Automatic Control:	Forward AGC, Pulse-operated AGC, Diode AFC, (Automatic Noise Suppressor)
Power Requirements:	AC 220V, 50 Hz, DC 12V Battery
Power Consumption:	AC 13.0W, (Maximum) DC 7.7W (Maximum)
Dimensions:	8-7/8" (W) x 8-7/8" (D) x 5-5/8" (H)
Weight:	9 lbs. 8 Oz.

SONY[®]
SERVICE MANUAL

TABLE OF CONTENTS

	Page
Specifications for the SONY Transistor TV-500UET	1
BLOCK DIAGRAM	3
EXTERNAL VIEW	3~4
MAJOR PARTS LOCATION	5
METHOD OF DISASSEMBLING THE SET	
Removal of the Rear Cabinet Cover	6
Removal of the Upper Cabinet Cover	6
Removal of the Deflection Circuit Board	7
Removal of the Signal Circuit Board	7
Removal of the High Voltage Block	8
Removal of the Tuner Block	8~9
Removal of the VHF Tuner	10
Removal of the UHF Tuner	10
Removal of the Speaker	10
Removal of the Picture Tube.....	11~12
Removal of the Protector	12
ADJUSTMENT PROCEDURE	
VIF Response Adjustments	13
SIF Adjustments	13
Deflection Circuit Board Adjustments	14
MOUNTING DIAGRAM	
Deflection Circuit Board (Component Side)	15
Signal Circuit Board (Component Side)	16
Signal Circuit Board (Conductor Side).....	17
Deflection Circuit Board (Conductor Side)	18
CIRCUIT SCHEMATIC	
General	19~20
UHF and VHF Tuner	21
EXPLODED DIAGRAM	
Tuner Block	22
Right Side Chassis	23
Main Chassis	24
Cabinet	25~26
Packing	27

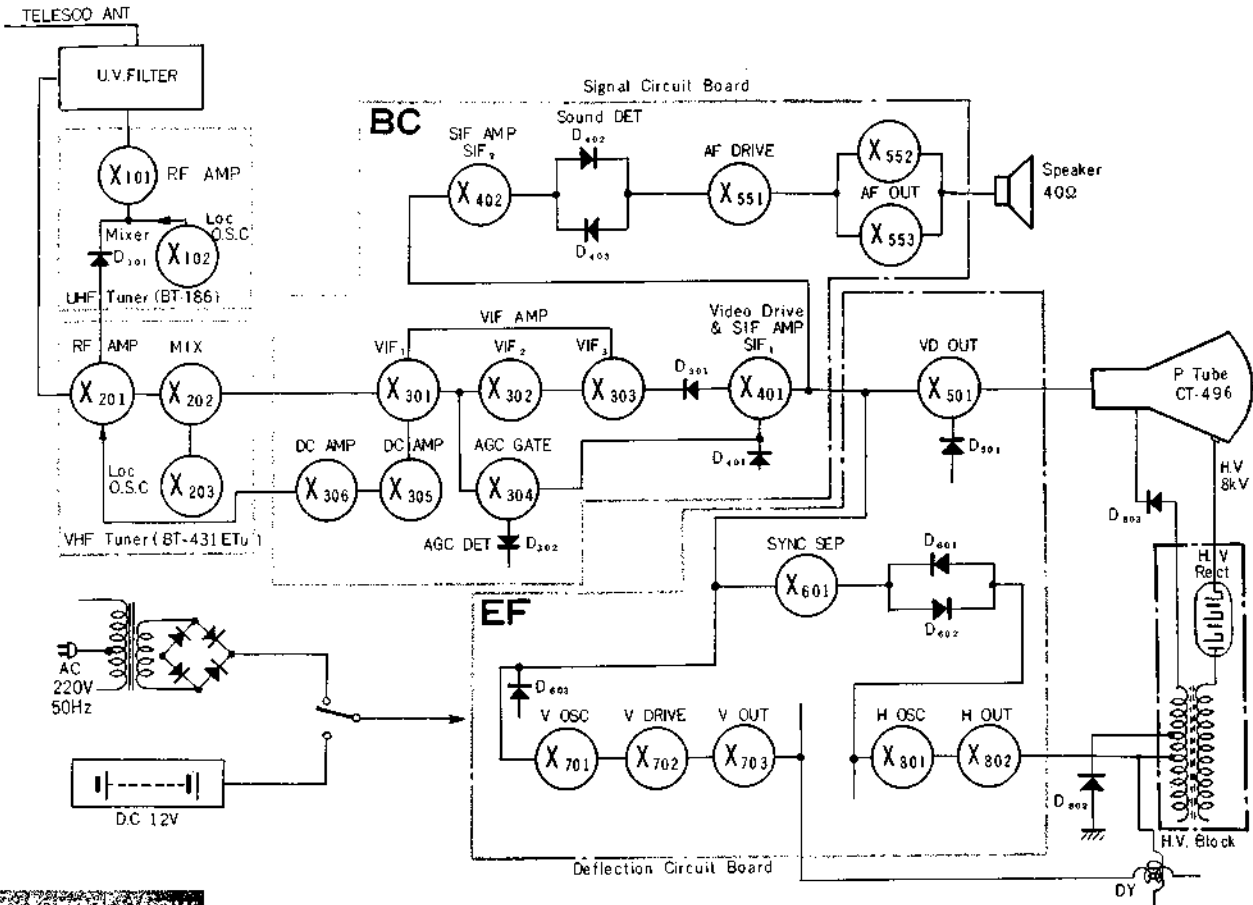

External View

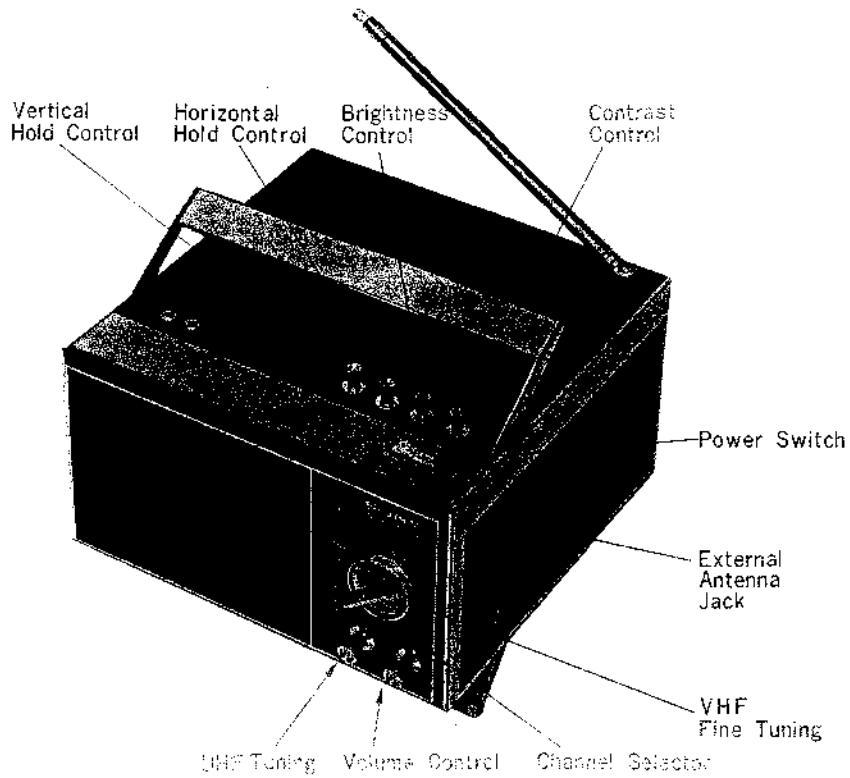

TV-500UET

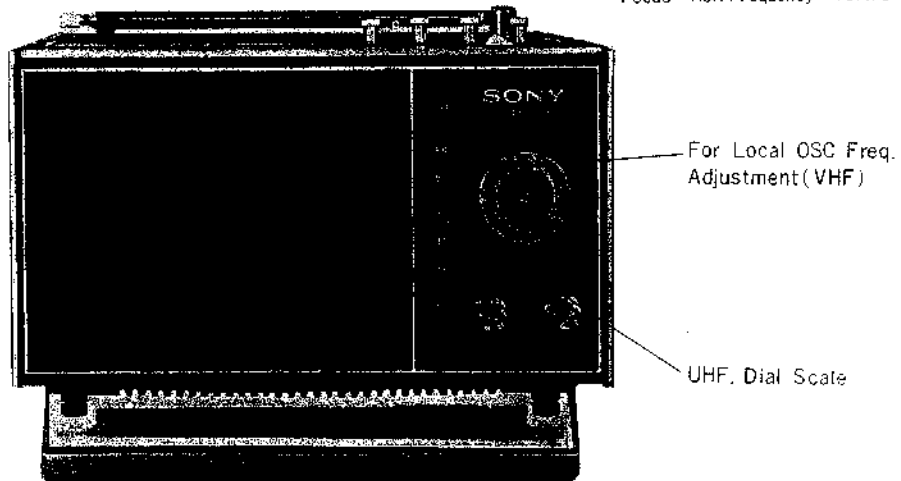
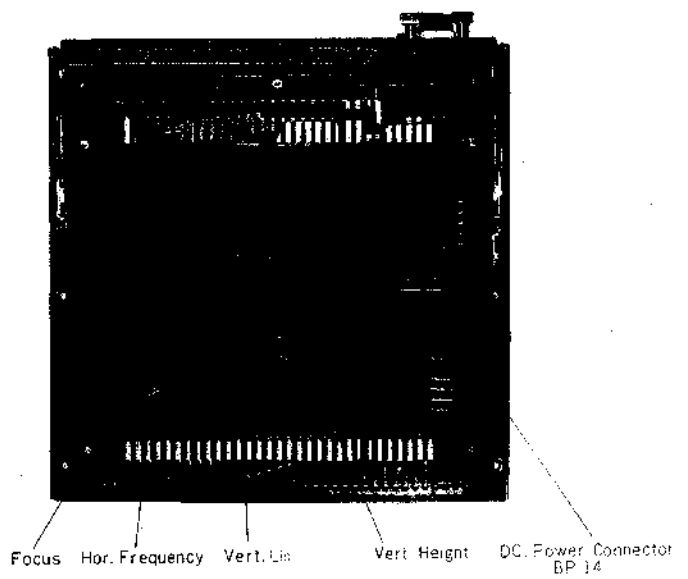
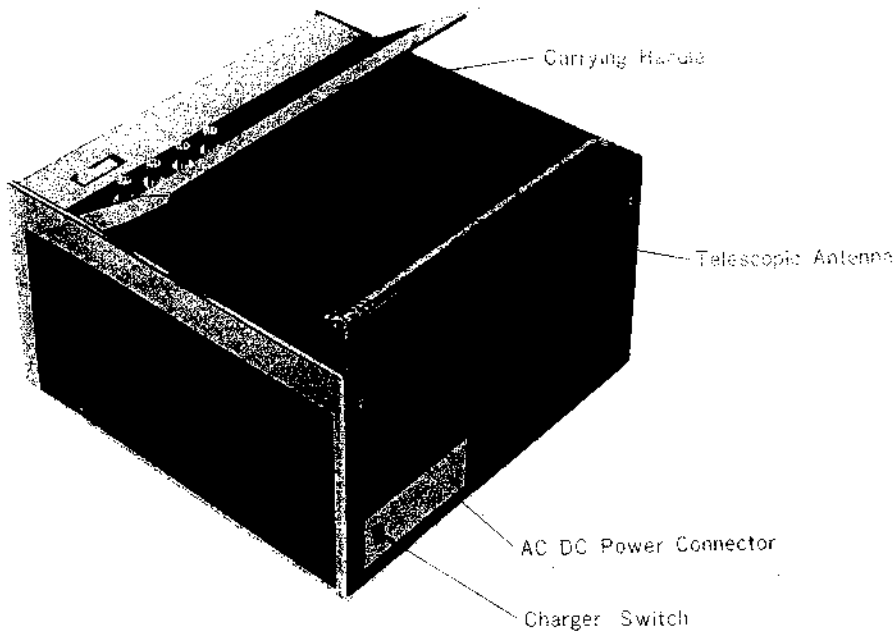

Major Parts Location

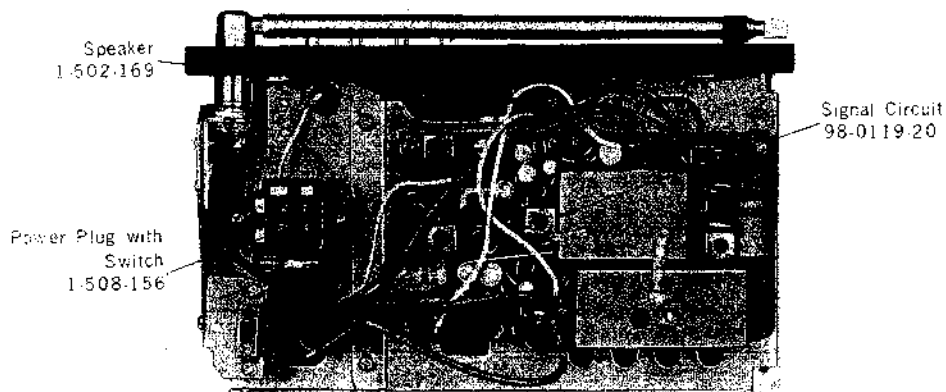
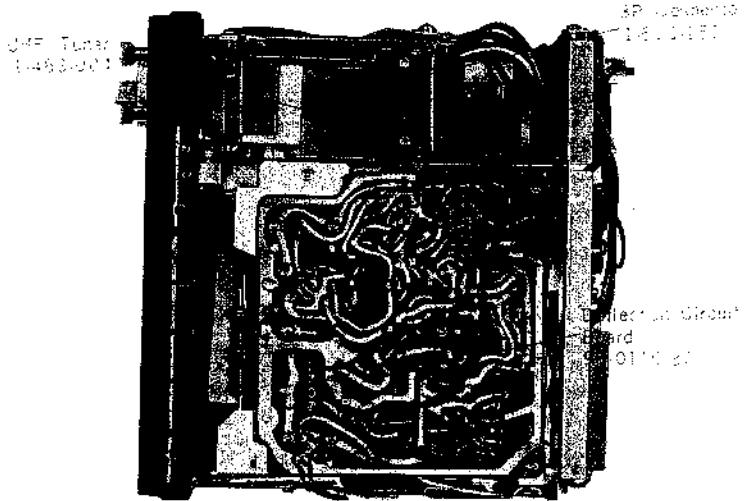
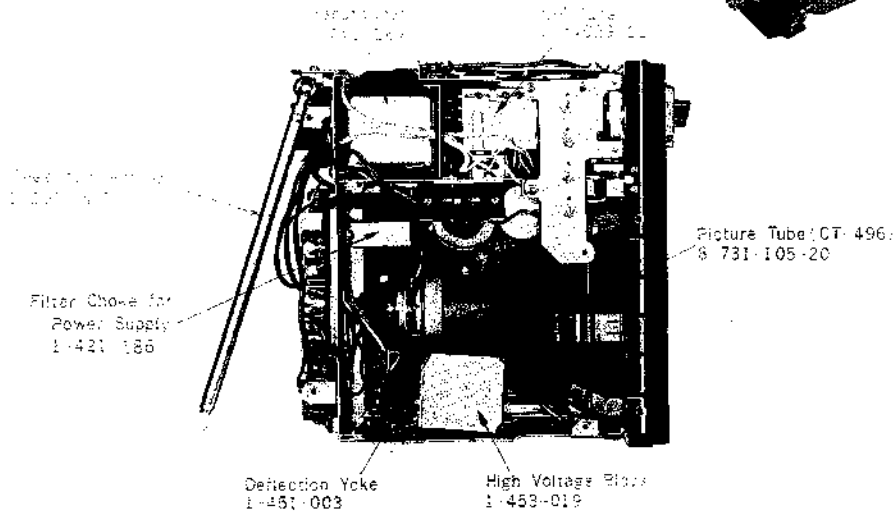
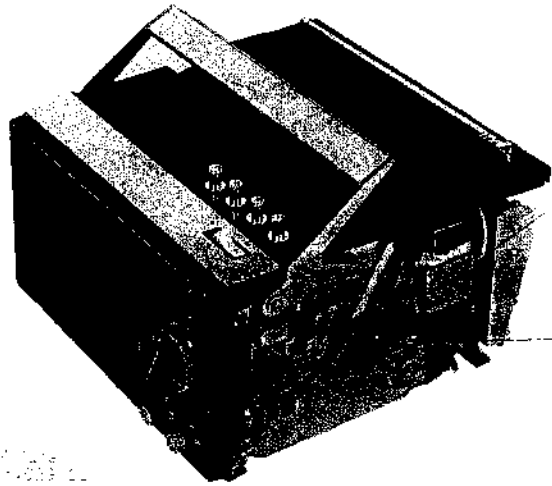

V-500UET

Method of Disassembling the Set

To Remove the Rear Cabinet Cover

- (1) Remove the Screws (Ⓐ in Fig. 1).
- (2) Remove the four Feet (Ⓐ, Ⓑ, Ⓒ and Ⓓ in Fig. 2).

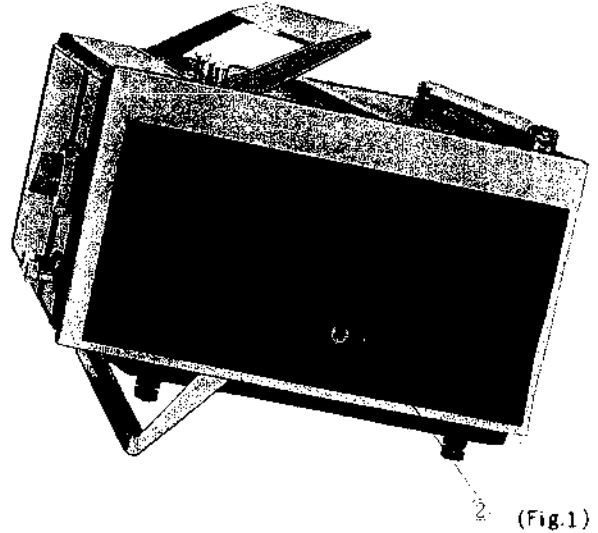

(Fig. 1)

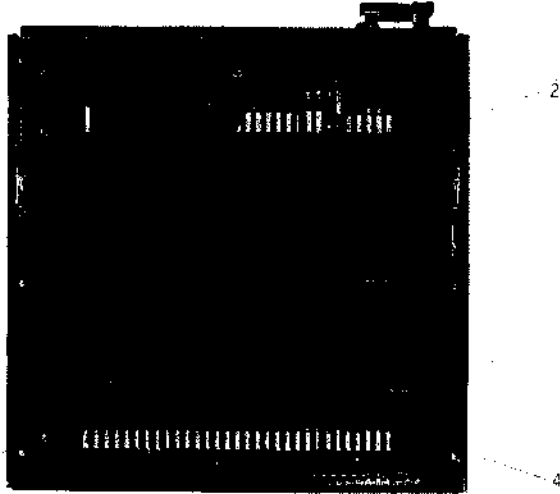

(Fig. 2)

To Remove the Upper Cabinet Cover

- (1) Remove the four Screws (Ⓐ, Ⓑ, Ⓒ and Ⓓ in Fig. 3).
- (2) Pull four Control Knobs Straight out (Ⓔ in Fig. 3).

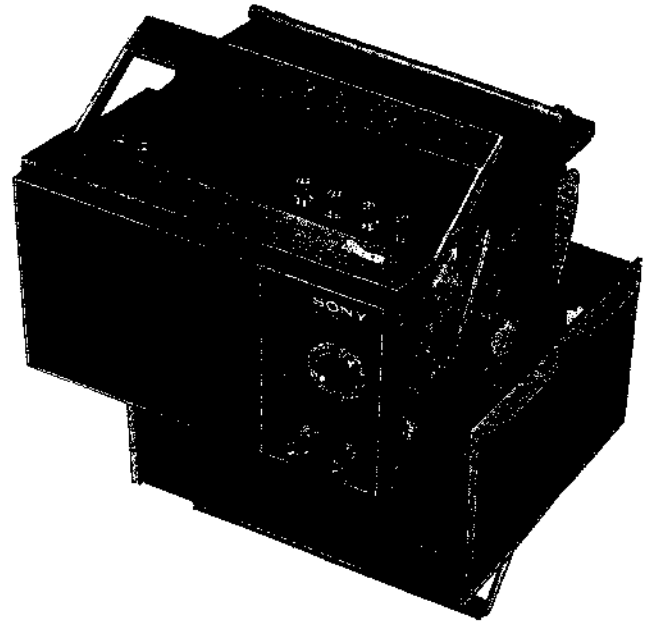

To Remove the Upper Ornamental Plate

- (1) Remove the Screws (Ⓐ in Fig. 4).

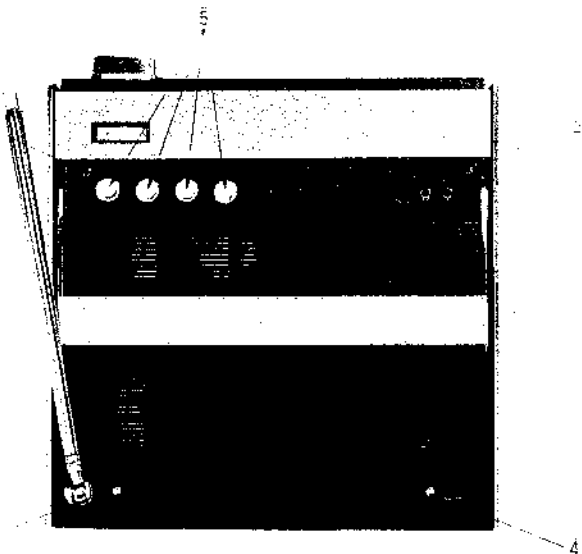

(Fig. 3)

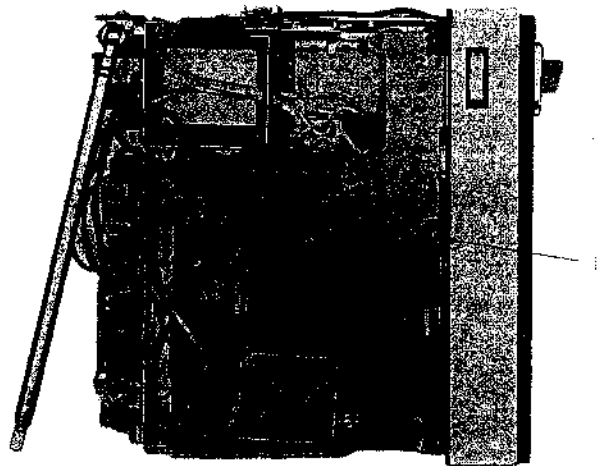

(Fig. 4)

To Remove the Deflection Circuit Board

- (1) Remove the four Screws (A, B, C, and D) in Fig. 5, 6).
- (2) Pull out the six Connectors (1, 2, 3, 4, 5, and 6) in Fig. 7).
- (3) Unsolder the nineteen Leads (1 ~ 19) in Fig. 7).

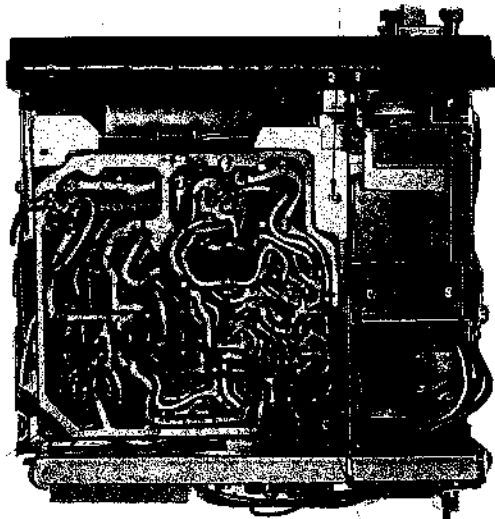

(Fig. 5)

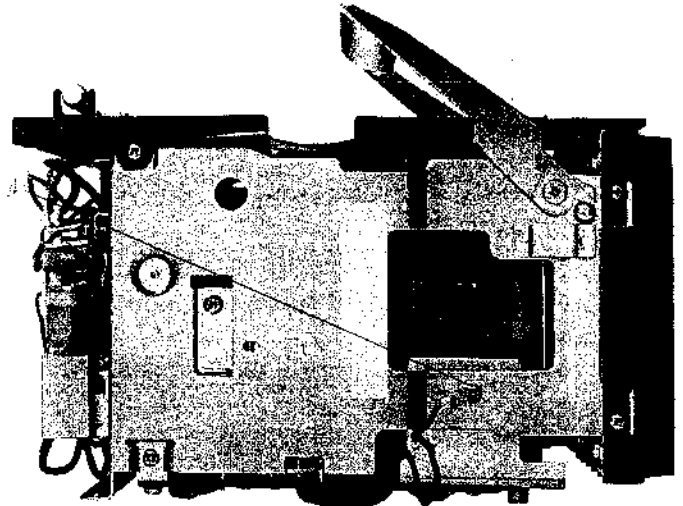

(Fig. 6)

To Remove the Signal Circuit Board

- (1) Unsolder the three Shielded Leads, one Co-axial Cable and eight Leads (1 ~ 8) in Fig. 8).
- (2) Remove the three Screws (A, B, and C) in Fig. 9).

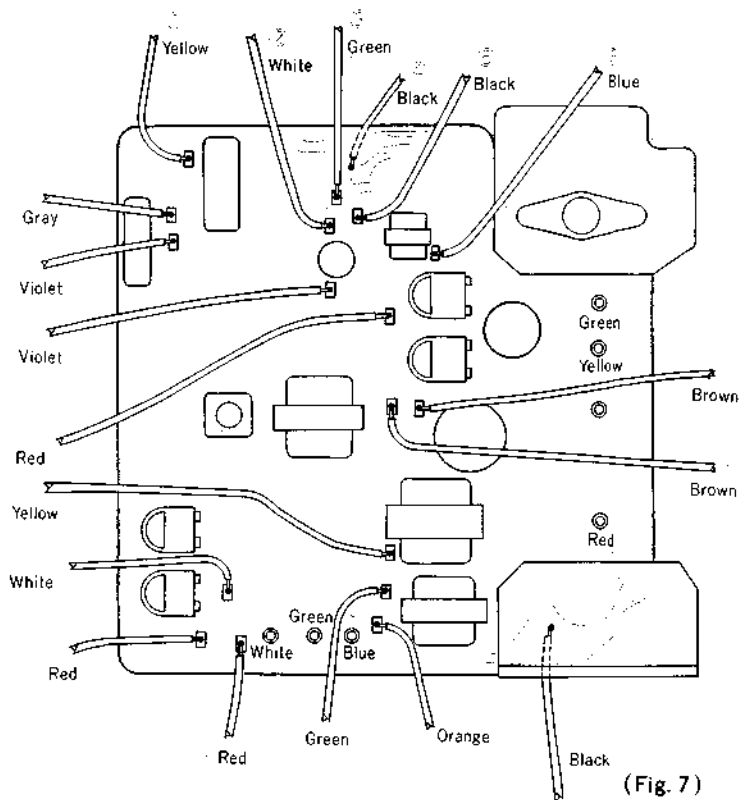

(Fig. 7)

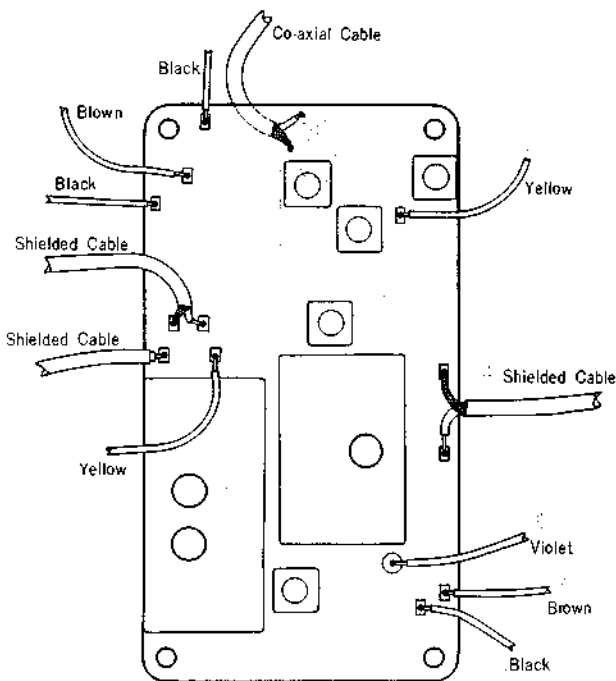

(Fig. 8)

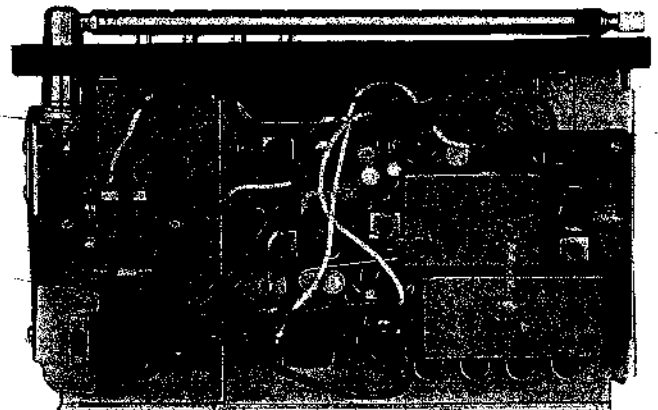

(Fig. 9)

To Remove the High Voltage Block

- (1) Remove the three Screws (①, ② and ③ in Fig. 10).
- (2) Remove the Anode Cap (④ in Fig. 10).
- (3) Pull out High Voltage Block from the Chassis (Fig. 11).
- (4) Unsolder all the corresponding Leads on the High Voltage Block.

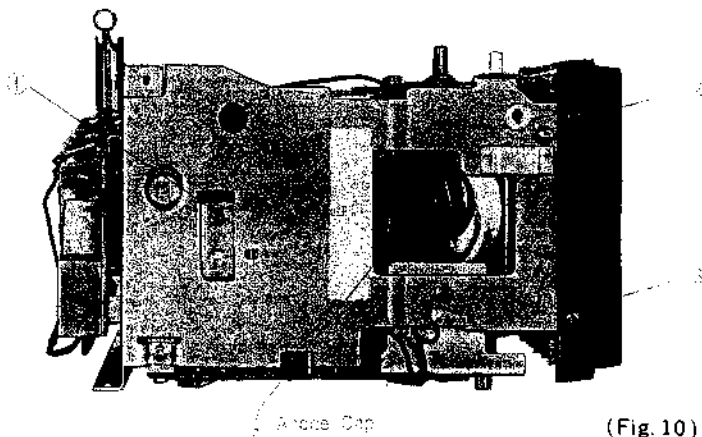

(Fig. 10)

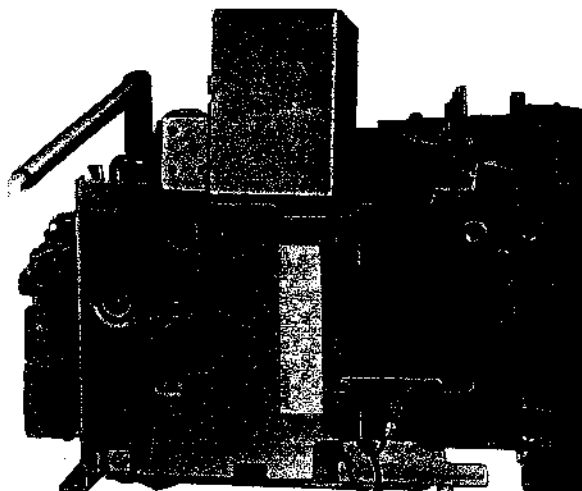

(Fig. 11)

To Remove the Tuner Block

- (1) Remove the Potentiometer Holding Plate by removing two Screws (①, ② in Fig. 12).
- (2) Pull out VHF Channel Selector Knob, VHF Fine Tuning Knob, UHF Tuning Knob and Volume Control Knob (Fig. 13).
- (3) Remove the eight Screws (③, ④, ⑤, ⑥, ⑦ and ⑧ in Fig. 12, 14 and 15).
- (4) Tuner block can now be detached from the Chassis.

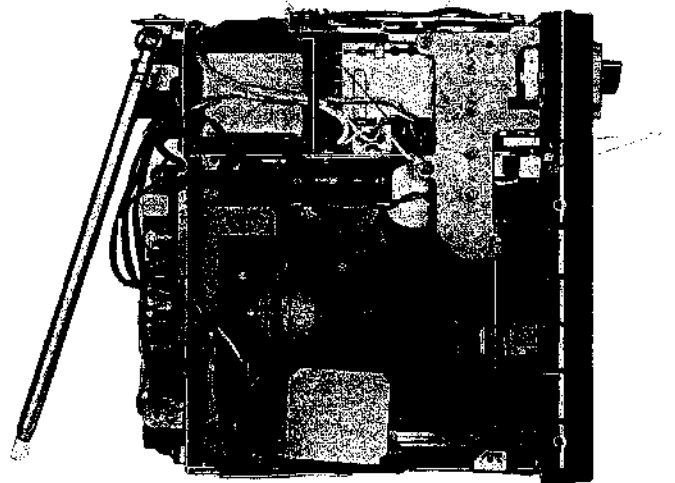

(Fig. 12)

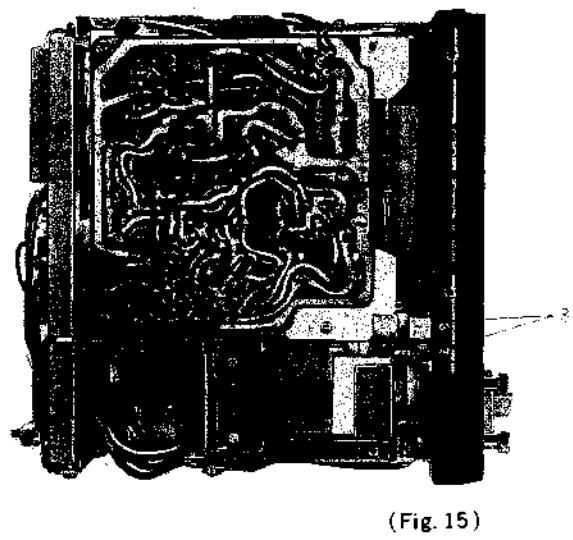
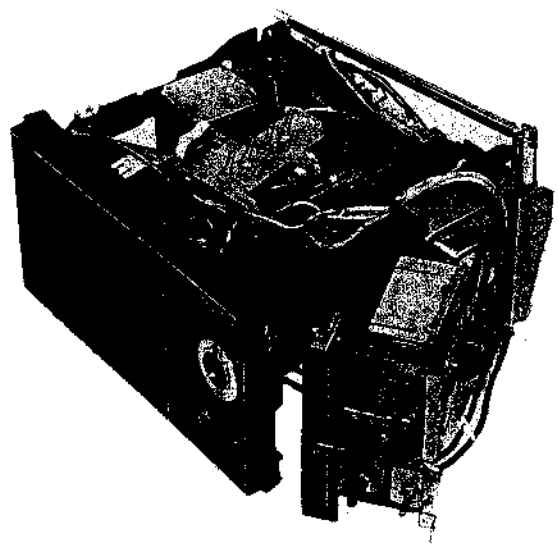
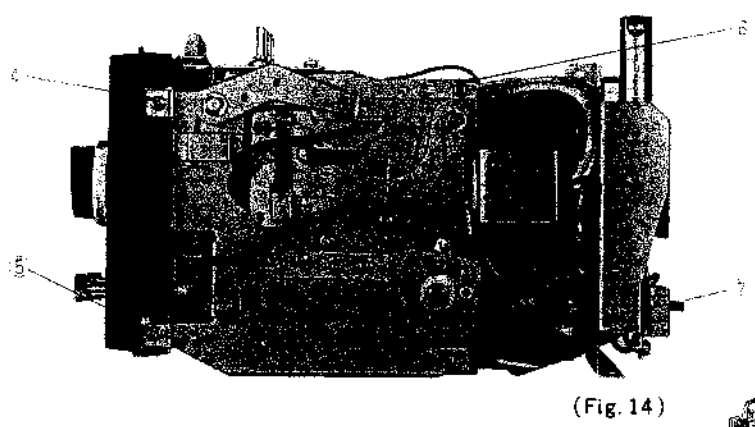
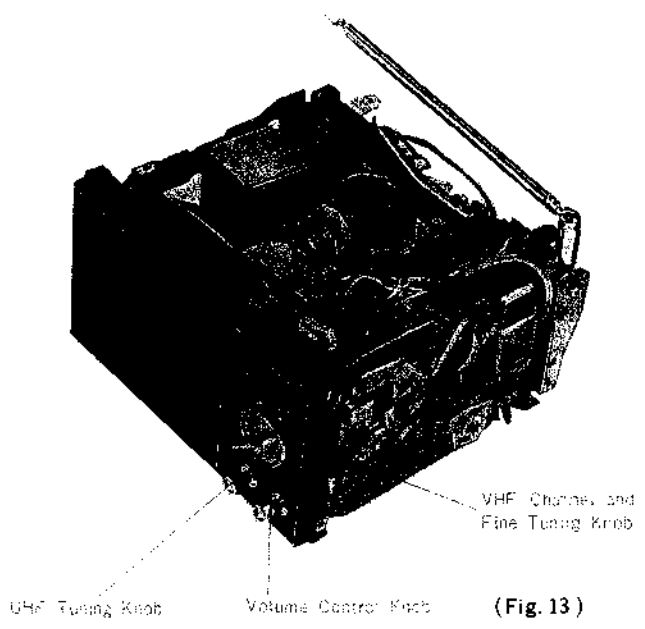

To Remove the VHF Tuner from the Tuner Block

- (1) Remove the three Screws (Ⓐ, Ⓑ and Ⓒ in Fig. 16).
- (2) Unsolder all the Corresponding Leads on the VHF Tuner Block (Fig. 17).

To Remove the UHF Tuner from the Tuner Block

- (1) Pull out the Dial Drum (Ⓓ in Fig. 16).
- (2) Remove the 14 ϕ Nut (Ⓔ in Fig. 16).
- (3) Unsolder all the Corresponding Leads on the UHF Tuner Block (Fig. 17).

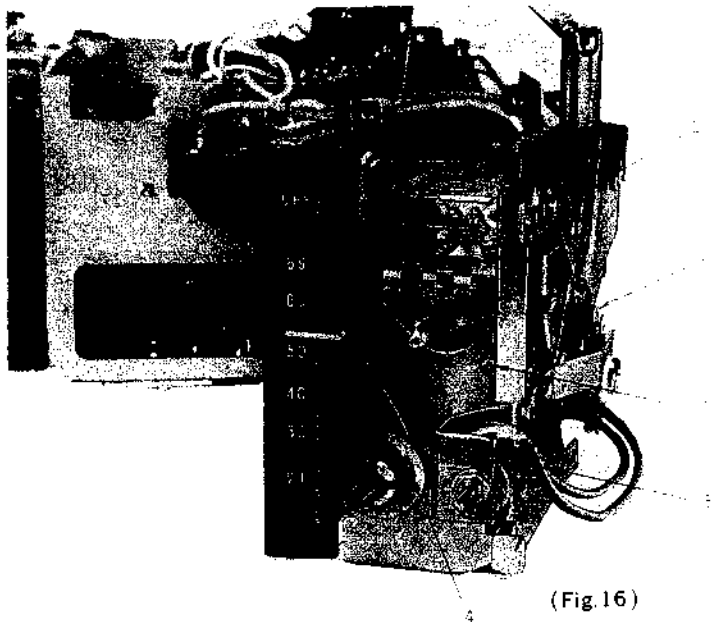

(Fig. 16)

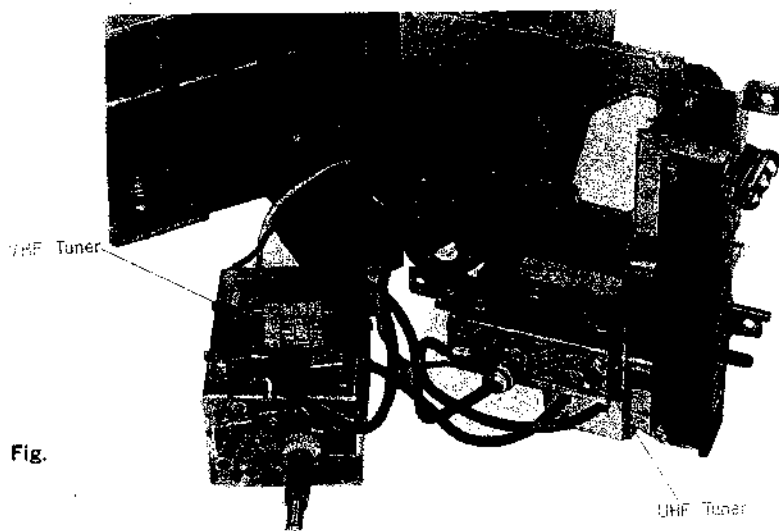

(Fig. 17)

To Remove the Speaker

- (1) Remove the Upper Cabinet Cover.
- (2) Remove the two Screws (Ⓢ in Fig. 18).
- (3) Unsolder the two Leads (Black and White in Fig. 18).

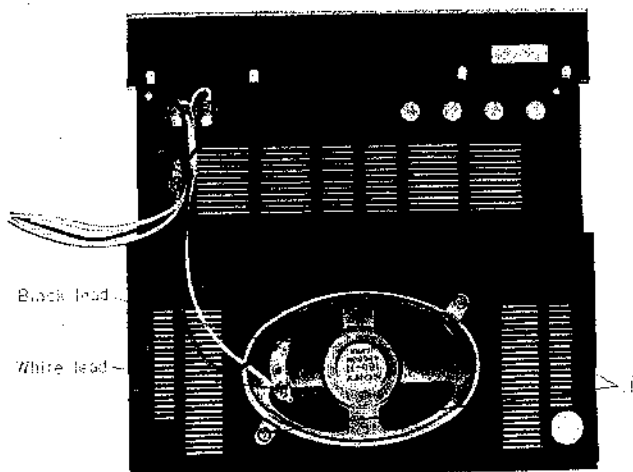

(Fig. 18)

To Remove the Picture Tube-1

- (1) Remove the Upper Cabinet Cover and Rear Cabinet Cover.
- (2) Remove the eight Screws (A, B, C, D, E, F, G, and H in Fig. 19, 20, 21 and 22).

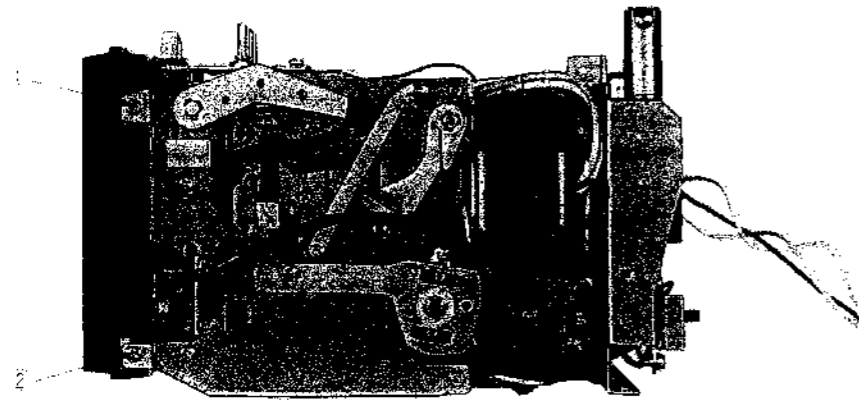

(Fig. 19)

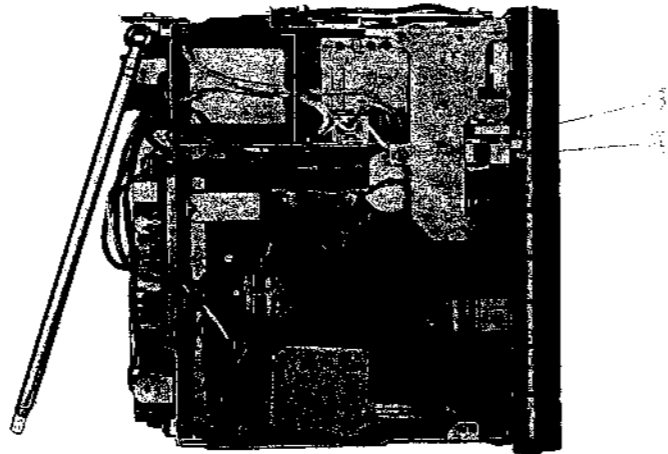

(Fig. 20)

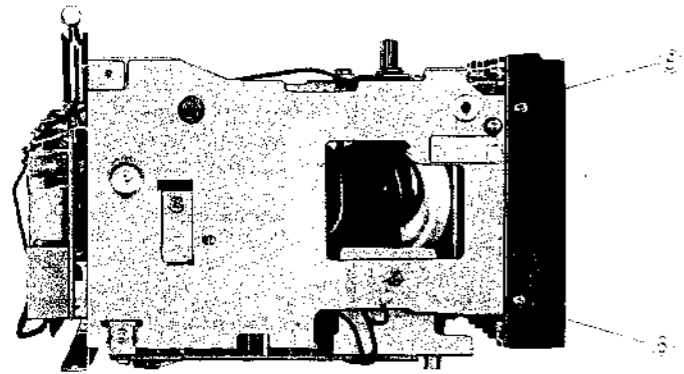

(Fig. 21)

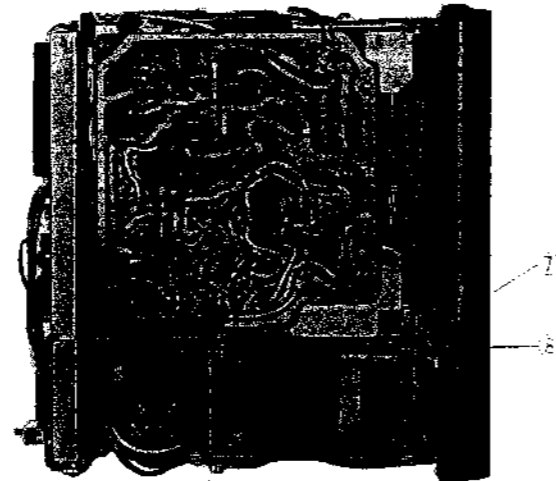

(Fig. 22)

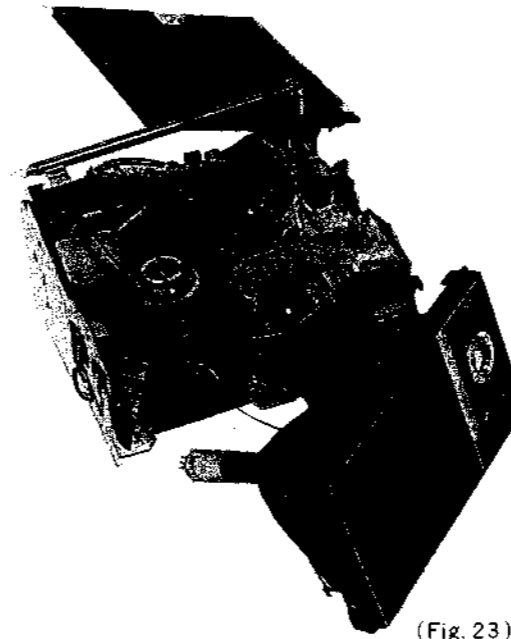

(Fig. 23)

To Remove the Picture Tube-2

- (3) Remove the Front Cabinet from the Chassis (Fig. 23).
- (4) Loosen the Picture tube Clamp Screws (I in Fig. 24).
- (5) Remove the four Screws (J, K, L and M in Fig. 24).

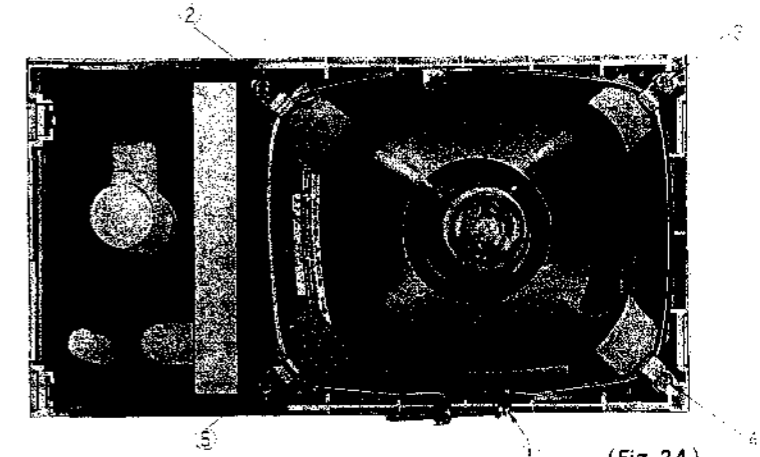

(Fig. 24)

To Remove the Protector

- (1) Remove the Upper Cabinet Cover and Rear Cabinet Cover.
- (2) Remove the four Screws (N, O, P and Q in Fig. 25, 26).
- (3) Pull out Protector from the Front Cabinet (Fig. 27).

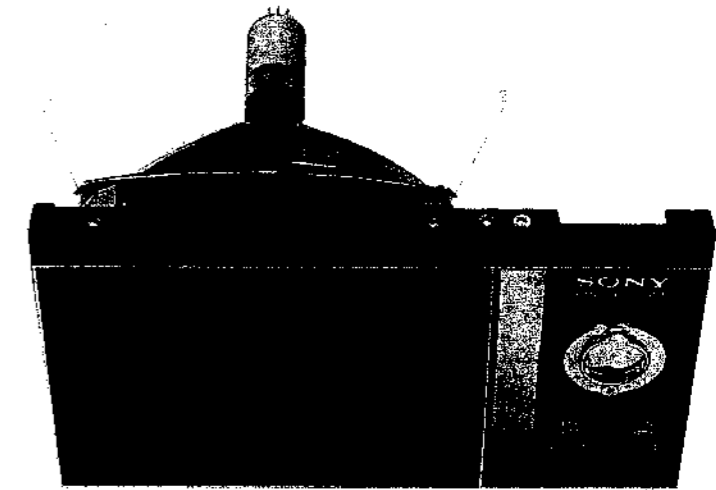

(Fig. 25)

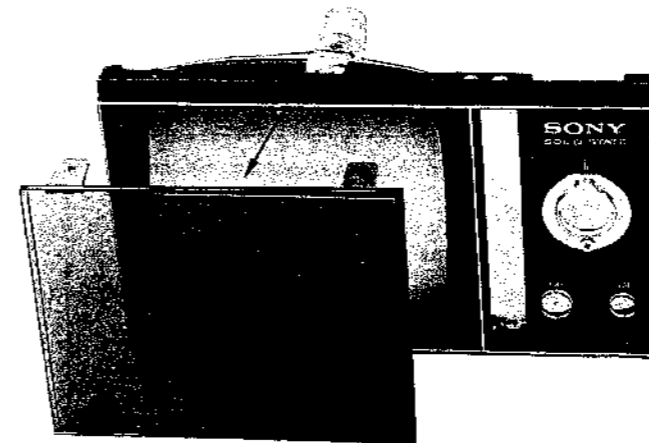

(Fig. 27)

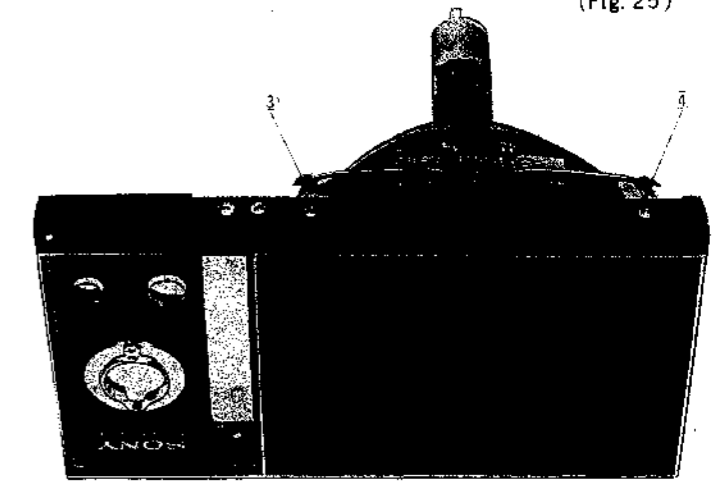

(Fig. 26)

Adjustment Procedure

A. VIF Response Curve Adjustments

Pre-Alignment Steps

- (1) Unsolder the Keying Pulse Lead.
- (2) Connect an Oscilloscope to the Base of X_{101} and the ground through a Noise Filter, which consists of a 10K Ω resistor and a 300 μ F Capacitor as shown in Fig. 28.
- (3) Connect a Sweep Generator and a Marker Generator to the Test Point (TP) of the Tuner through a 0.001 μ F capacitor.
- (4) Set the Tuner to a free channel in area.

Step	Marker Gen. Freq.	Adjust	Correct Marker position on the response curve	Remarks
1	33.4 Mc	TRAP-1	⊖ (dip)	VIF Standard Response Curve. See Fig. 29.
2	40.4 Mc	TRAP-2	⊖ (dip)	
3	35.25 Mc	VIFT-2	⊖ (50%)	
4	38.9 Mc	VIFT-3	⊖ (45%)	
5	38.15 Mc	VIFT-3 VIFT-4	⊖ (100%—1.4 Vpp)	

If a proper response curve similar to Fig. 29 is not obtained by the adjustment procedures described above, replace the damping resistor (R_{304} or R_{311}) with proper one for best result.

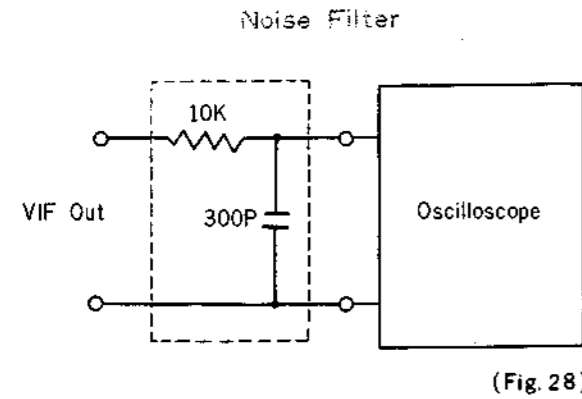

(Fig. 28)

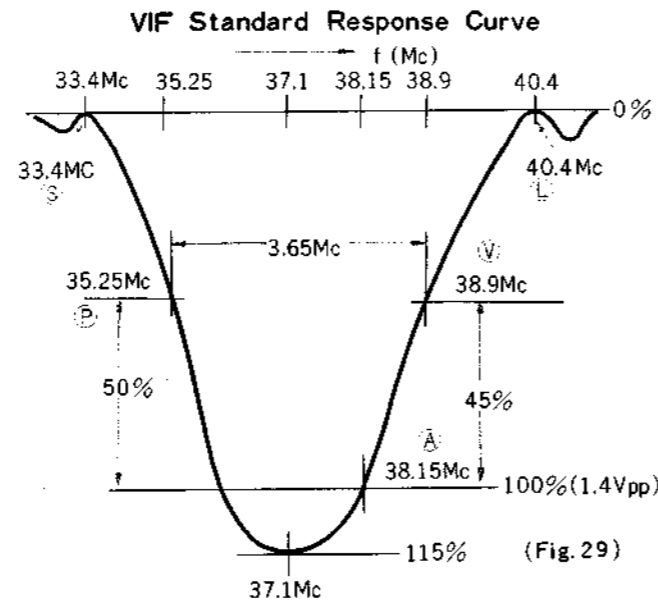

(Fig. 29)

B. SIF Adjustments

Pre-Alignment Steps

- (1) Set the Brightness Control to the optimum and the Contrast Control to the maximum positions.
- (2) Remove the Tuner Output Leads.
- (3) Connect a 5K Ω resistor across SIF output terminal and ground.

Step	Equipment	Connection	Freq.	Adjust	Remarks
1	Test Oscillator	VIDEO DET OUT	5.5 Mc	TRAP-3	for minimum stripes on the picture.
2	Same	Same	5.5 Mc	SIFT ₁ & Pri. of SIFT ₂ (Pink)	for maximum reading on the Voltmeter.
3	Voltmeter	Across R_{311}		Sec. of SIFT ₂	for minimum modulated waveform.
	Sweep Gen.	VIDEO DET OUT	5.5 Mc (AM)		
	Standard Signal Gen.	Same			
	Oscilloscope	SIF output terminals Across a Dummy resistor of 5K Ω			

- Note: (1) Repeat the above procedures two or three times.
- (2) If S curve is not symmetrical with respect to the intersection of the S curve and return line, adjust primary of SIFT₂ for optimum result.

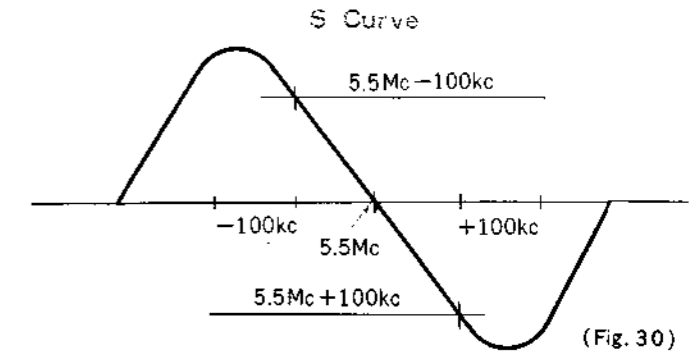

C. Deflection Circuit Adjustments

Step	Adjustment for	Preliminary Instruction	Equipment	Connection	Adjust	Remarks
1	Ic of X_{501} (VID. Out)	Set to free channel. Check 12V and 50V Power Supply.	Voltmeter	Across R_{504}	R_{502} (57K-75K Ω)	For approx. 18.5V reading.
2	Heater Voltage (Picture tube)	Check 12V Power Supply.	Voltmeter	Between Picture tube Heater Pins	R_{509} in parallel with R_{506}	For approx. 0.6V reading.
3	Ic of X_{703} (Vert. Out)	Lock in Sync. Check 12V Power Supply.	Same	Across R_{710}	R_{707} (120 Ω -1.5K Ω)	For approx. 0.38-0.41V reading.
4	Vert. Height and Linearity	Receive a Test Pattern.			VR_{703} (Vert. Linearity) VR_{702} (Vert. Height)	For optimum Vertical Height and Linearity on the Picture.
5	Pulse Width	Lock in Sync.	Oscilloscope	Emitter of X_{501}	C_{504} (0.068-0.22 μ F)	For 7.5-8.5 μ sec. (Fig. 31)
6	HSC (Horizontal Stability Coil)	Lock in Sync. Receive a Test Pattern.			HSC	So that the picture is stable in either case whether HSC is shorted or normal.
7	Horizontal Width	Lock in Sync. Brightness Controls to optimum positions.	Oscilloscope	Collector of X_{502}	C_{508} (0-0.015 μ F)	For 11.6-12.2 μ sec. (Fig. 32)
8	Horizontal Frequency	Set the Contrast and Brightness Controls to optimum positions. Receive a Test Pattern.			VR_{602} (Hor. Freq.)	To obtain same number of diagonal bars by applying some electrical shocks respectively when setting VR_{601} to fully clockwise and counter-clockwise positions.
9	Focus	Same Lock in Sync.			VR_{601} (600K Ω)	To obtain best focus on the picture.

Waveform of Transistor X_{501} Emitter

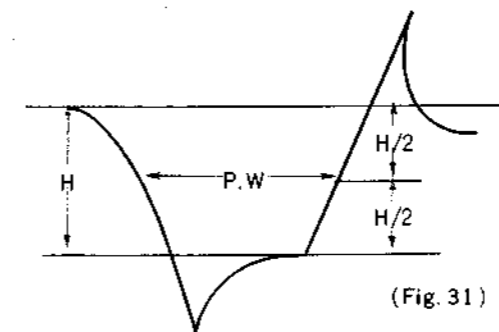

Waveform of Transistor X_{502} Collector

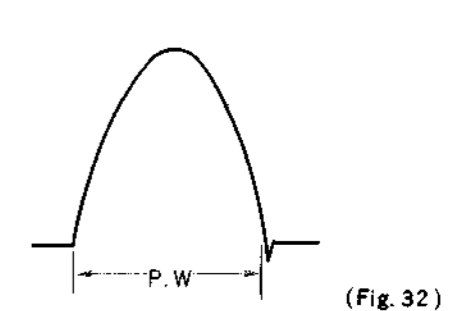

Mounting Diagram
Deflection Circuit Board
—Components Side—

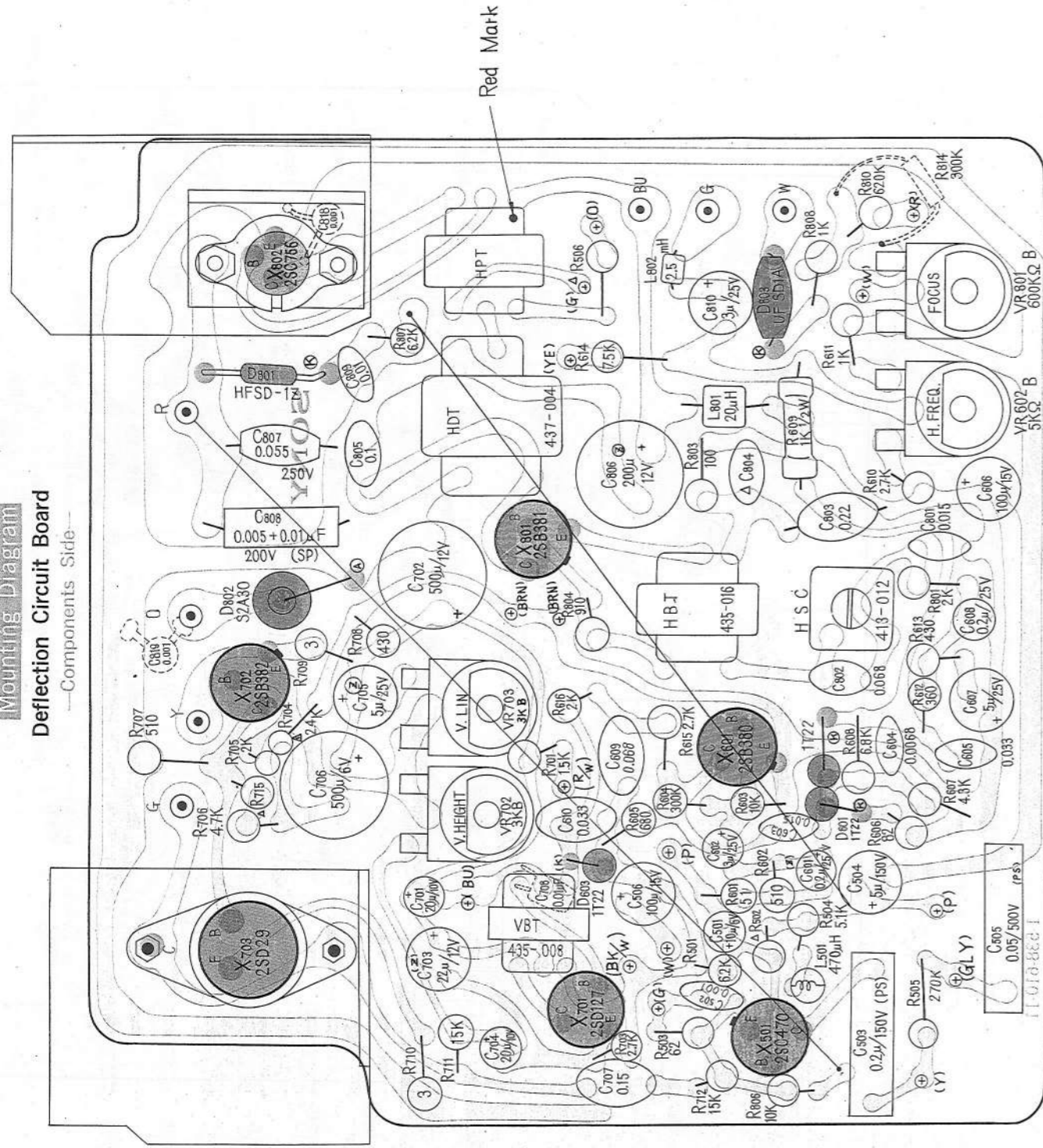

Note: Serial No. 11501 and later X601 2SA202.

Mounting Diagram
Signal Circuit Board
—Components Side—

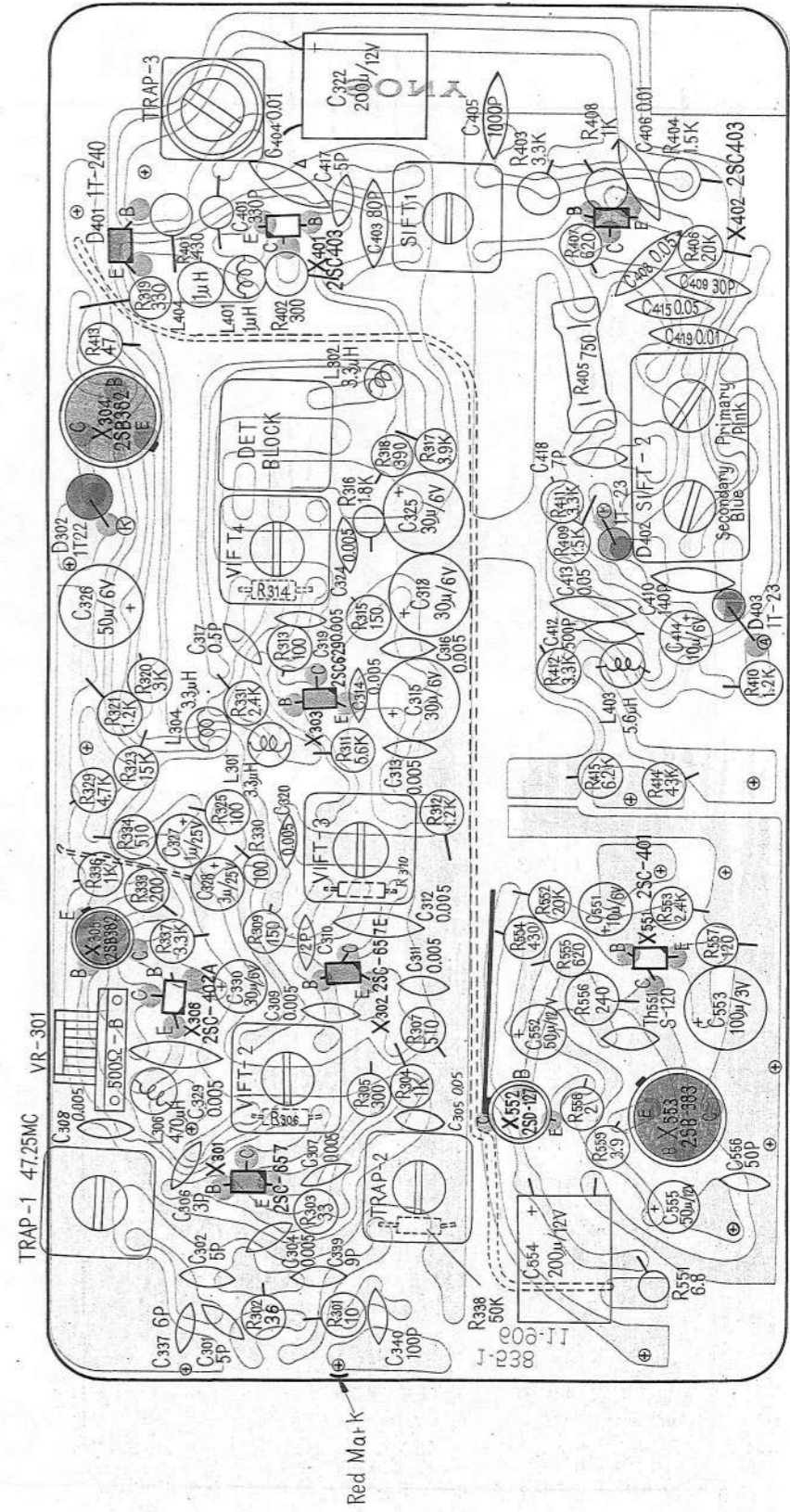

Mounting Diagram
Signal Circuit Board
—Conductor Side—

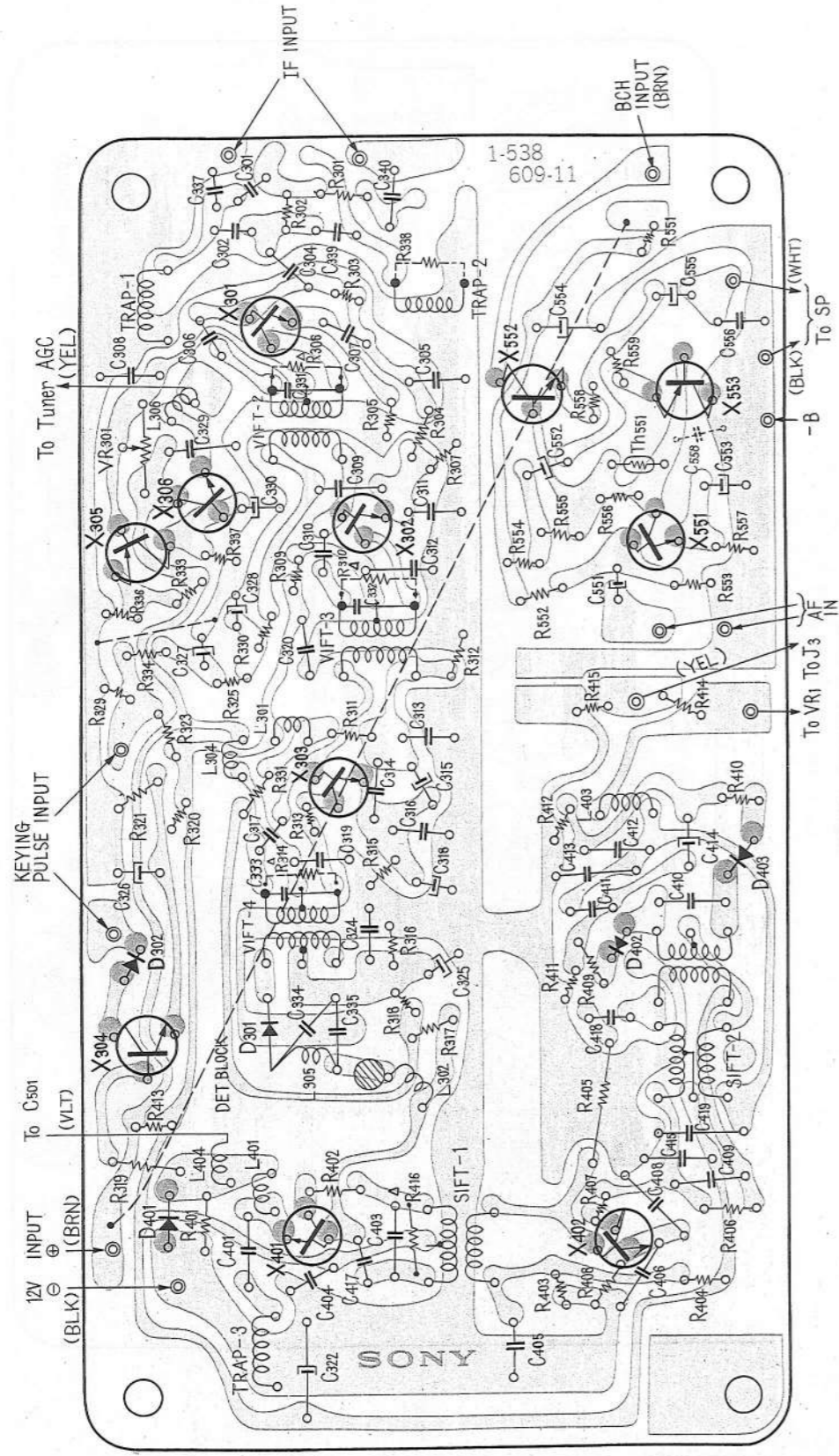

R306 R310 R314 R416 and C558 Mounted on the Conductor side

Mounting Diagram
Deflection Circuit Board
—Conductor Side—

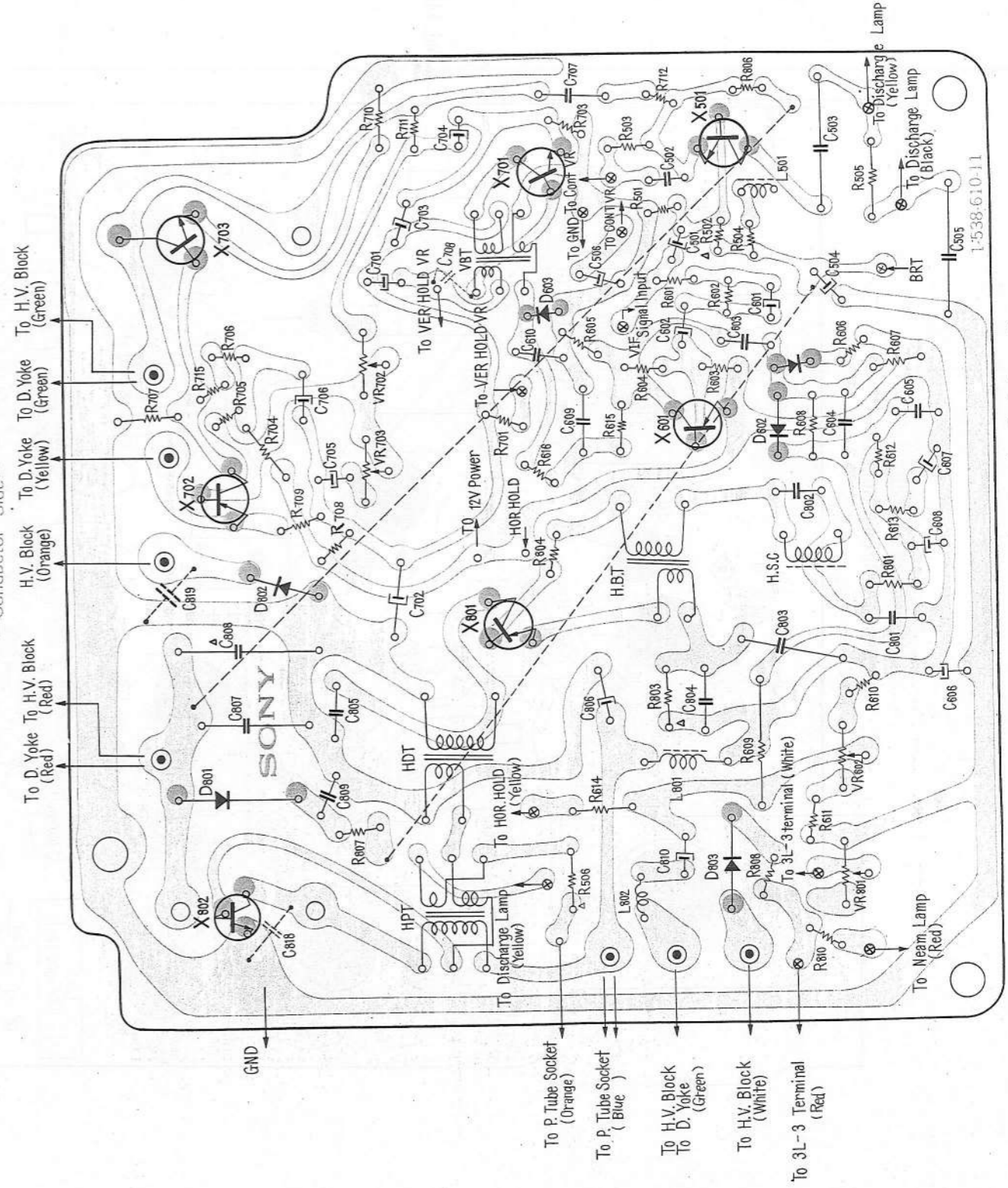

C818 C819 and C820 Mounted on the Conductor side

TV-500UET TV-500UET

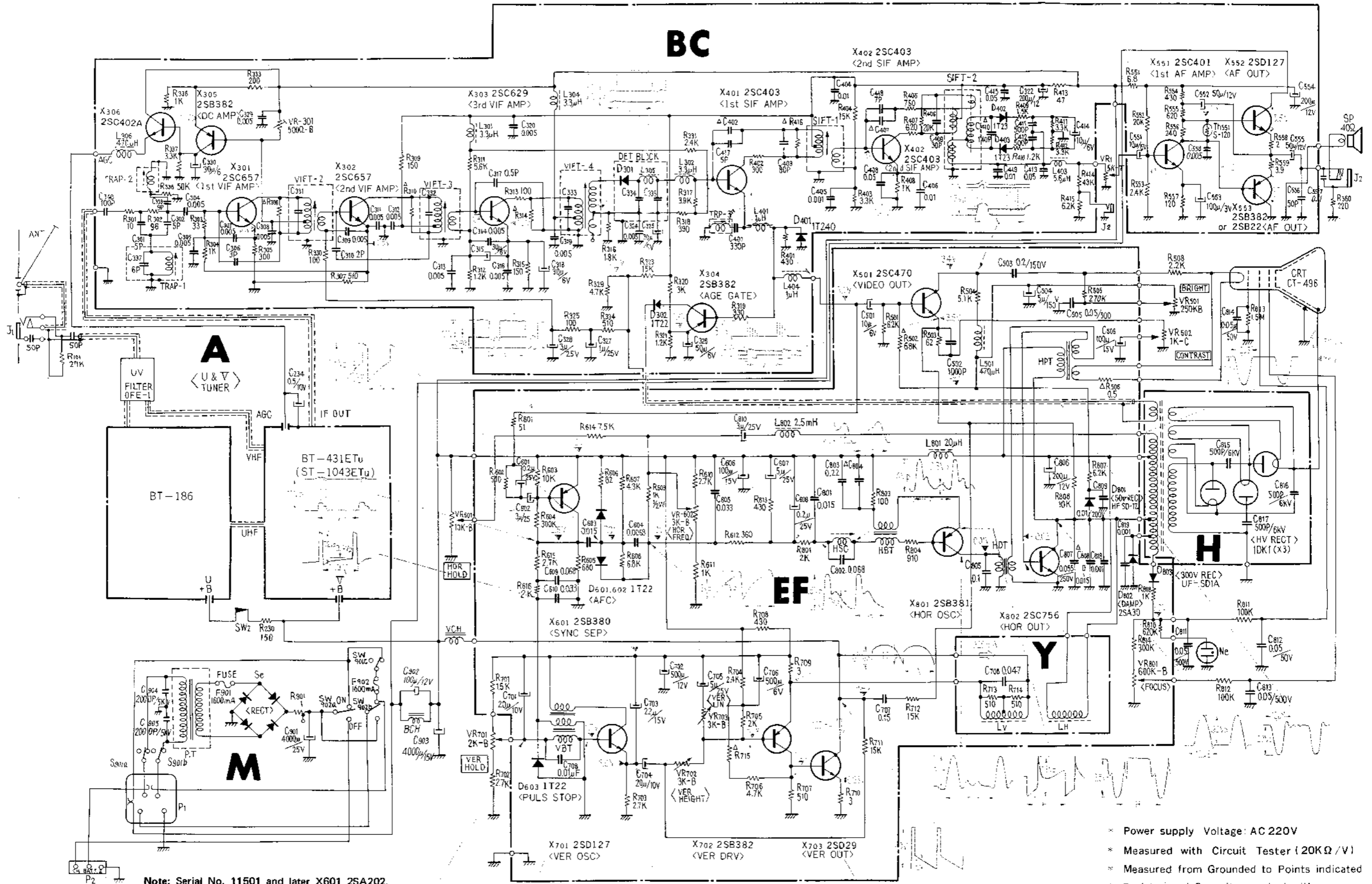

Note: Serial No. 11501 and later X601 2SA202.

- * Power supply Voltage: AC 220V
- * Measured with Circuit Tester (20KΩ/V)
- * Measured from Grounded to Points indicated
- * Resistor and Capacitor marked with Δ are to be adjusted.

Circuit Schematic

- Tuner Section -

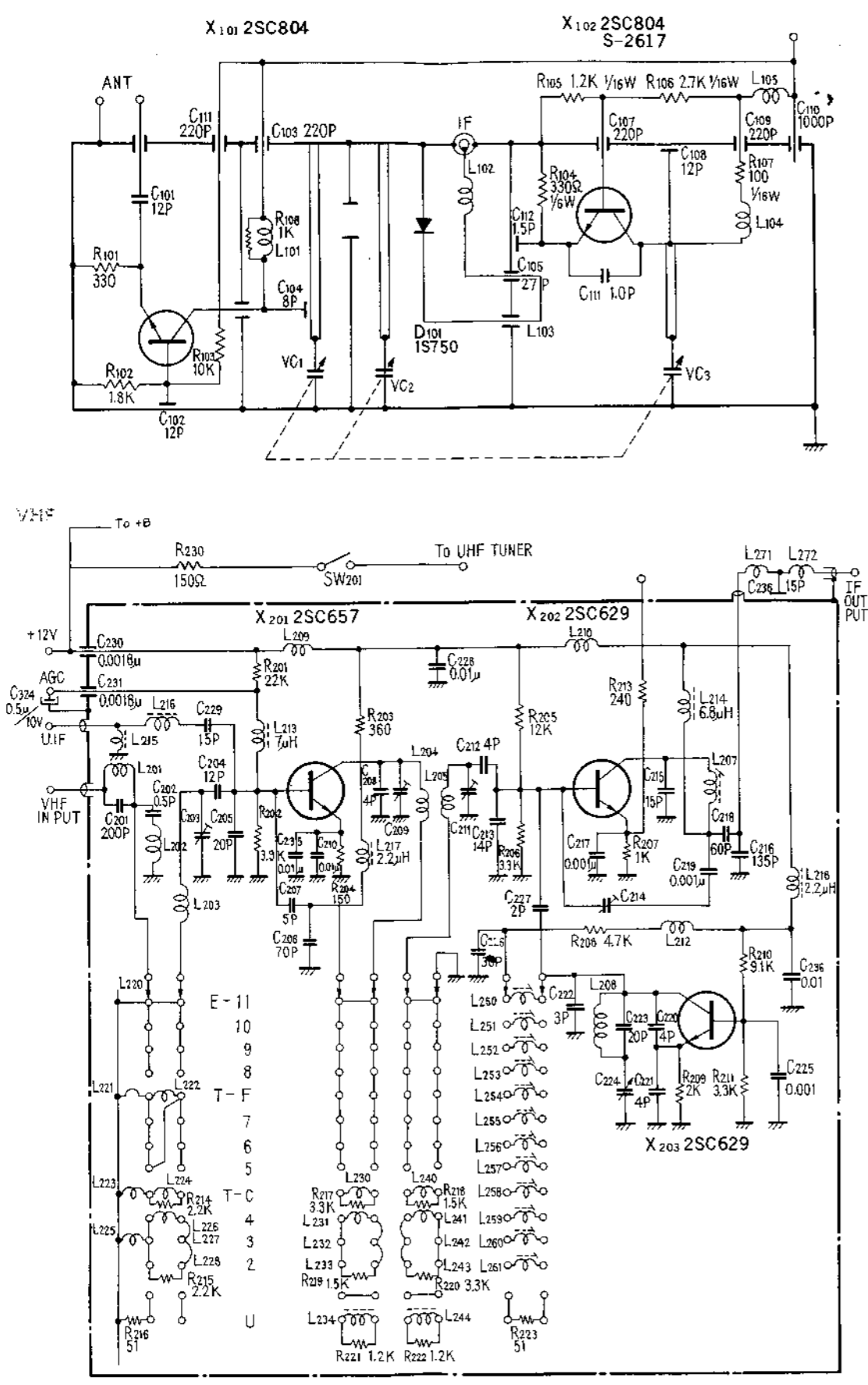

Exploded Diagram

Tuner Block

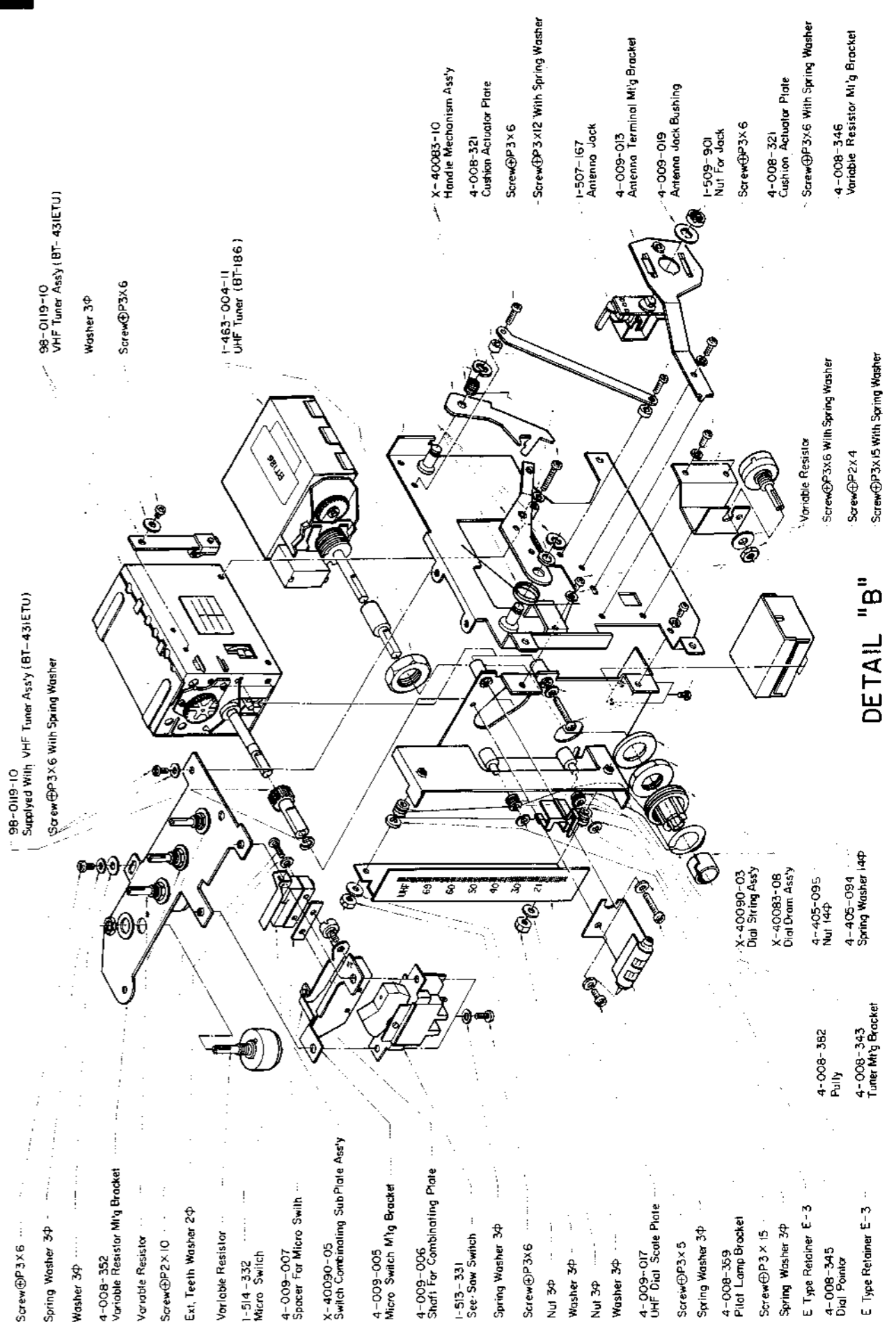

Exploded Diagram

Right Side Chassis

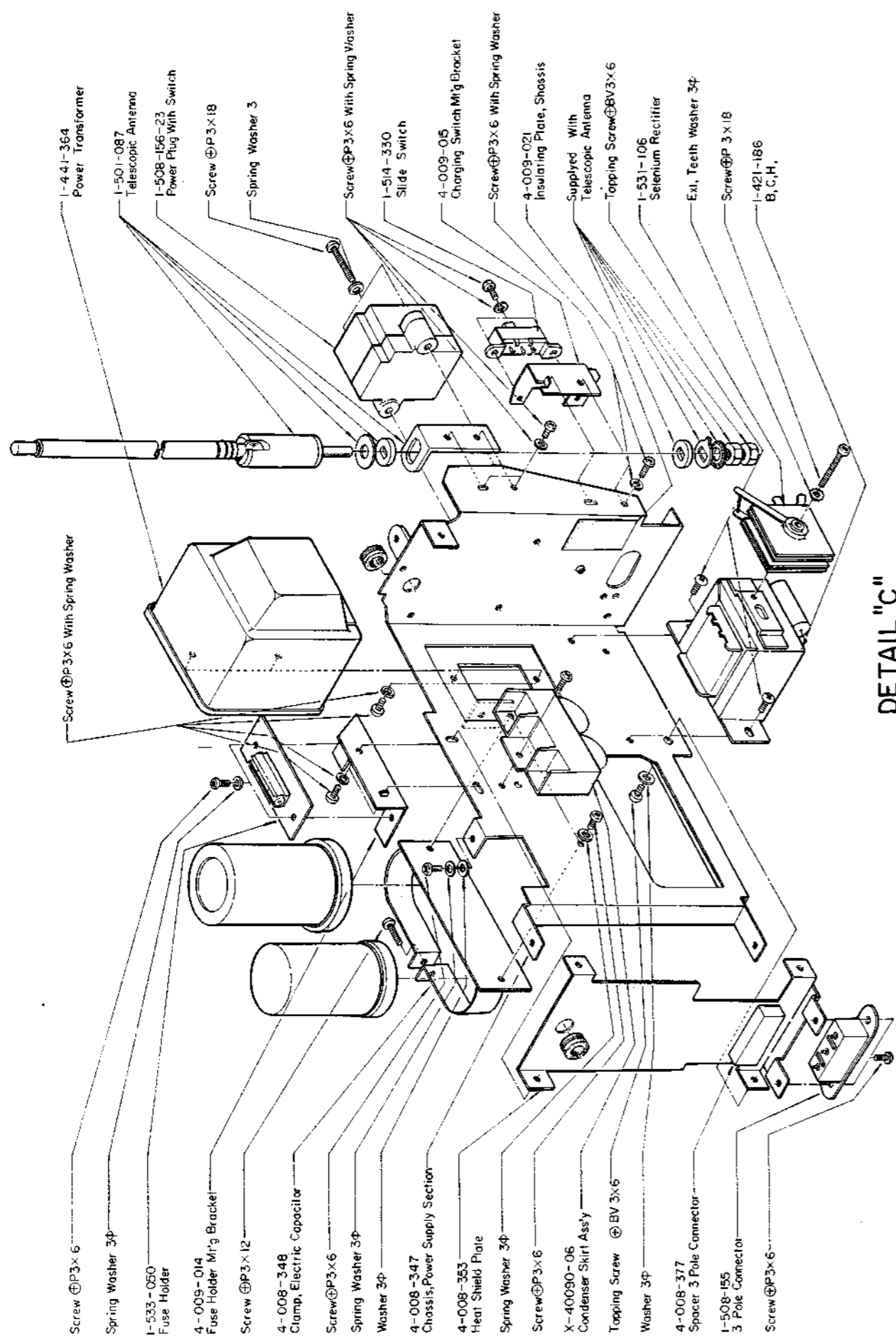

DETAIL "C"

Exploded Diagram

Main Chassis

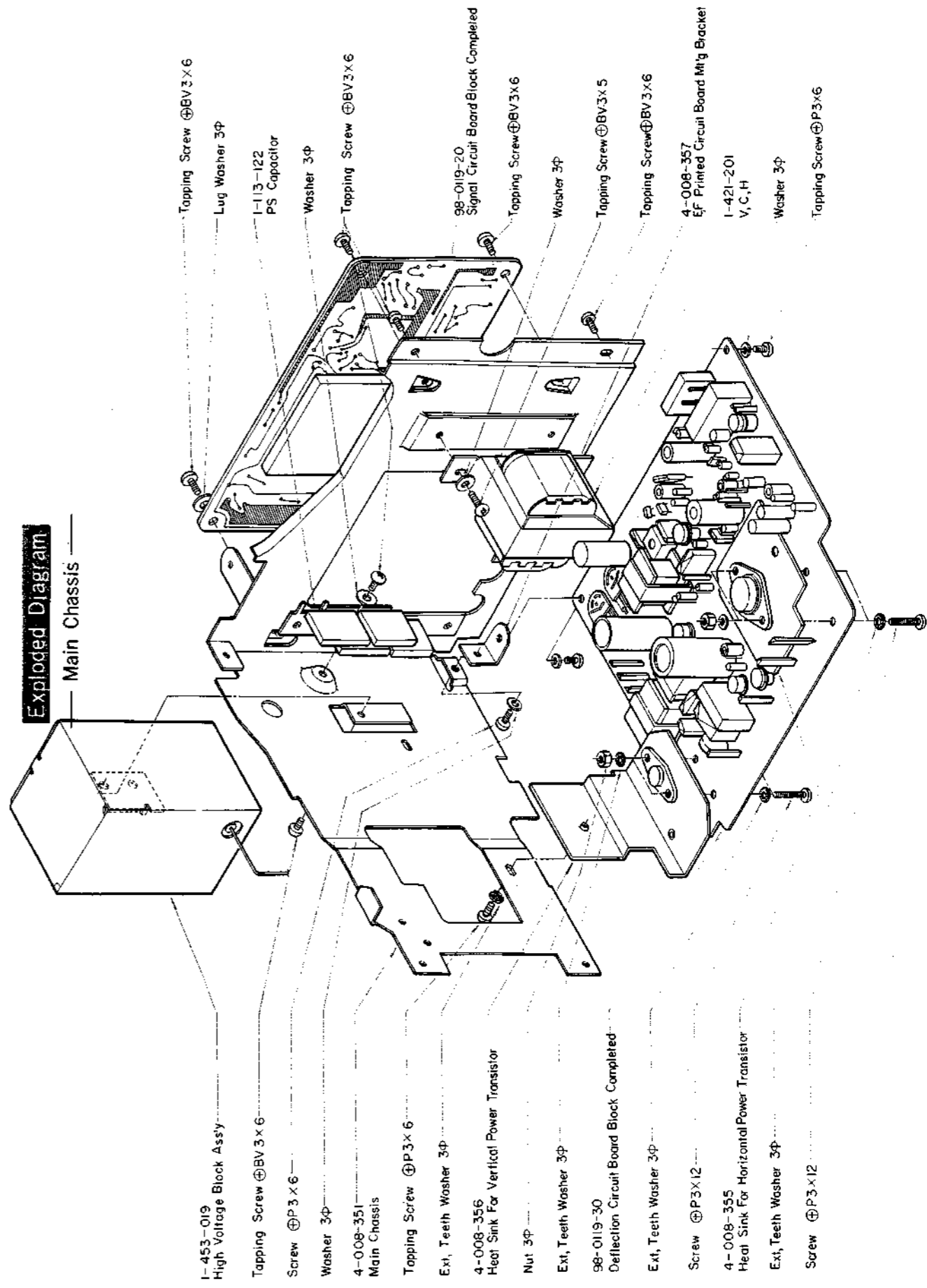

DETAIL "A"

TV-500UET TV-500UET

Exploded Diagram

Cabinet

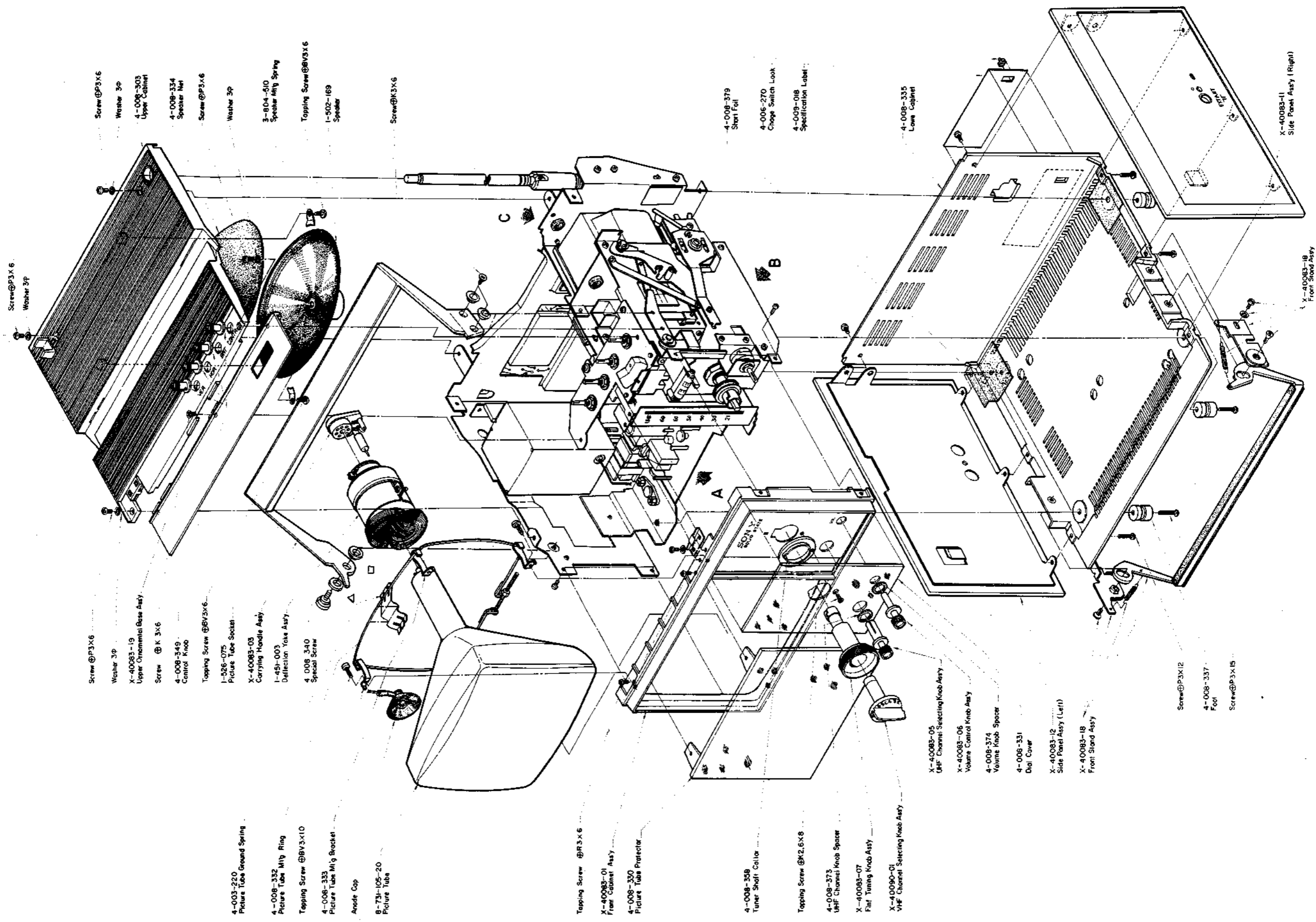

— Packing —

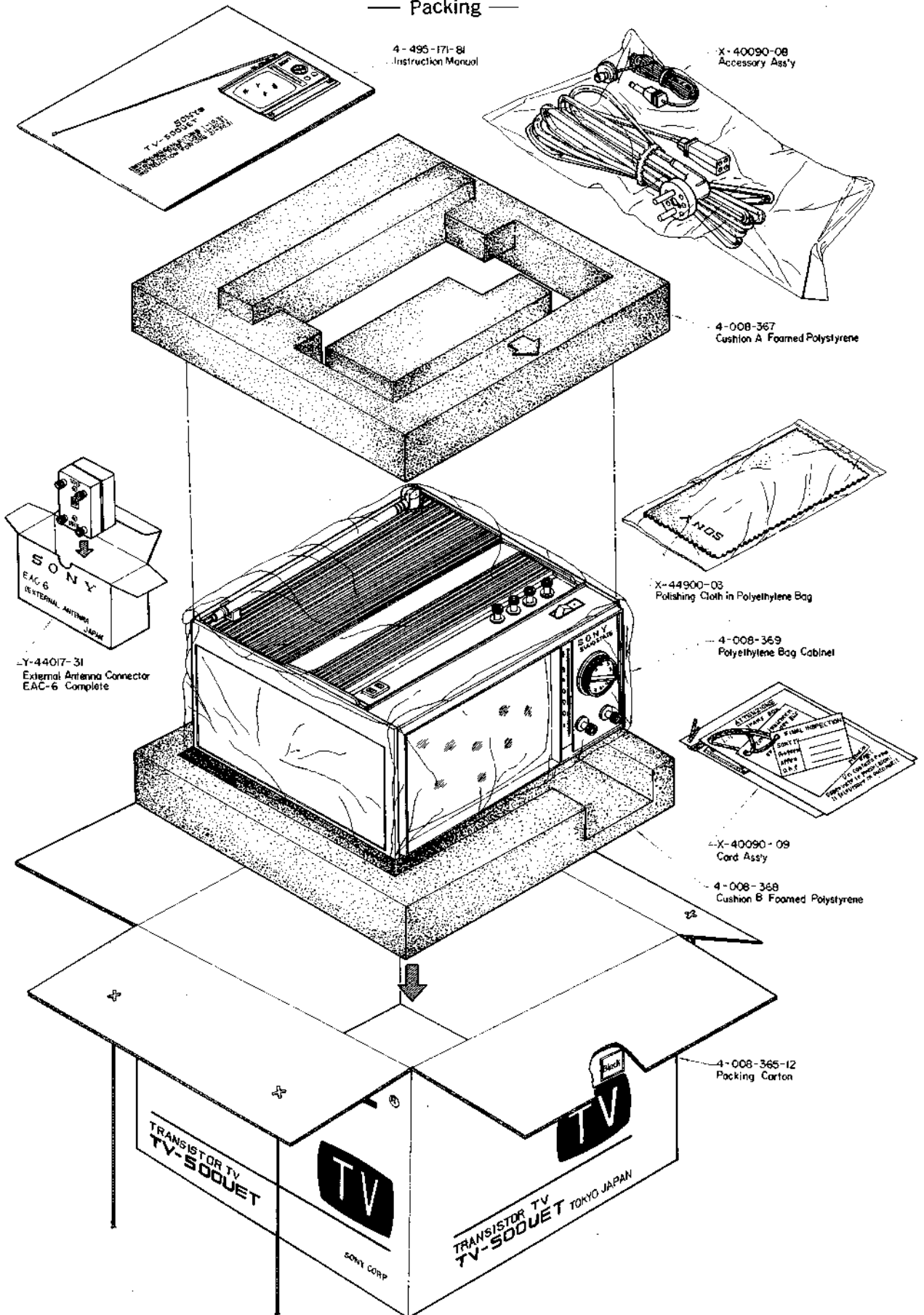

Betrieb mit der Batterie BP-12/563 (für TV-500UET)

Die Metallriegel an beiden Seiten des Batteriegehäuses werden herausgezogen und das Fernsehgerät aufgesetzt. Das Gleichstromkabel der Batterie wird in den Stromanschluß des Gerätes gesteckt. Dann wird das Gerät eingeschaltet. Es arbeitet jetzt mit Batteriestrom.

Aufladen der Batterie:

Dazu wird der Ladeadapter (wird mit der Batterie mitgeliefert) in den Stromanschluß des Fernsehgerätes gesteckt. Das Netzstromkabel des Gerätes wird an einen der Adapteranschlüsse angeschlossen und mit einer Wechselstromsteckdose verbunden. Das Gleichstromkabel der Batterie wird ebenfalls an den Adapter angeschlossen. Der Ladeschalter ist nach unten auf [CHARGE] zu schieben.

Wenn das Gerät nun eingeschaltet wird, beginnt das Aufladen der Akku-Batterie. Nach je 2 Stunden Benutzung soll die Batterie zwölf Stunden lang aufgeladen werden.

* Wenn nach häufigem Aufladen die Betriebszeit mit einer Batterieladung allmählich kürzer wird, so ist die Lebensdauer der Akku-Batterien erschöpft.

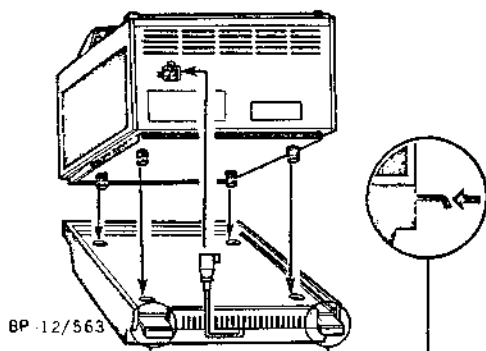

Funzionamento con BP-12/563 (per TV-500UET)

Tirate fuori le due chiavi metalliche che si trovano sul dorso del Pacco di pile. Procedete poi alla messa a posto sul medesimo Pacco del vostro apparecchio. Innestate il cavo di alimentazione di corrente continuata dalla pacco alla Presa di potenza in entrata dell'apparecchio. Mettete in marcia l'apparecchio, portando l'interruttore alla posizione marcata (ON) : ora, il vostro apparecchio ricevitore si trova pronto per funzionare con il Pacco di pile.

Ricarica:

Attaccate l'Adattatore-caricatore (fornito con il Pacco di pile) alla Presa di corrente di alimentazione del ricevitore. Innestate il cavo di alimentazione di corrente alternata ad una delle prese contatti dell'Adattatore. All'altra presa contatto del medesimo Adattatore viene innestato il cavo di alimentazione di corrente continuata dalla parte del Pacco di pile. Final-mente, collegate il cavo di alimentazione di corrente alternata a una presa di corrente di casa, mettete in marcia l'apparecchio e, allo stesso tempo, portate l'Interruttore di carica alla posizione inferiore marcata [CHARGE]. Ricaricate le pile interne per dodici ore per ogni consumazione di due ore.

* Se, dopo parecchie ricaricate, le pile non si ricaricano più, ne darà una evidenza immancabile l'effetto di scorcio sullo schermo.

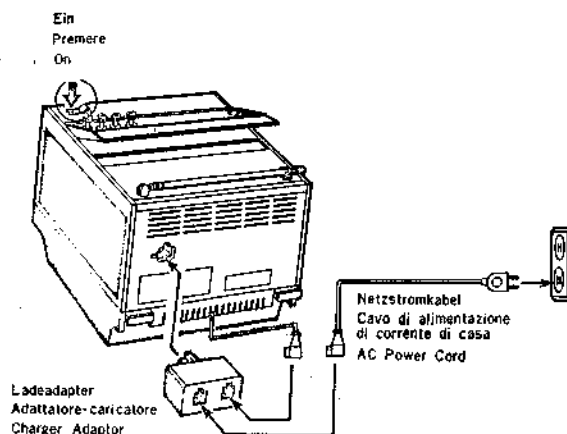

Operation on BP-12/563 (for TV-500UET)

Pull out the metal keys on both sides in the rear of the Battery Pack and place the set on it. Insert the DC power cord of the Battery Pack into the Power Socket of the set. Then turn the set ON, it will operate on the battery.

Recharging:

Attach the Charger Adaptor (supplied with the Battery Pack) to the Power Socket of the set. Connect the AC power cord to one of the outlets of the Adaptor and to the other connect the DC power cord of the Battery Pack. Then connect the AC power cord into an AC outlet, turn the set ON and set the Charging Switch to the down position [CHARGE]. Recharge the internal batteries for 12 hours for every 2 hours of battery operation.

* If after many charges, the batteries will not hold a charge, it is evidenced by a foreshortening of the TV Picture.

TV-500UET

SONY CORPORATION

TV-500UET (PTT)

SONY®

TV Service Bulletin No. 68-0001

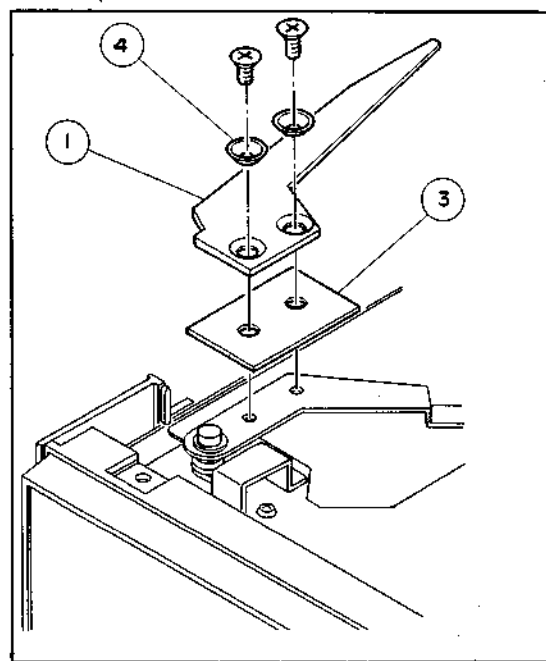
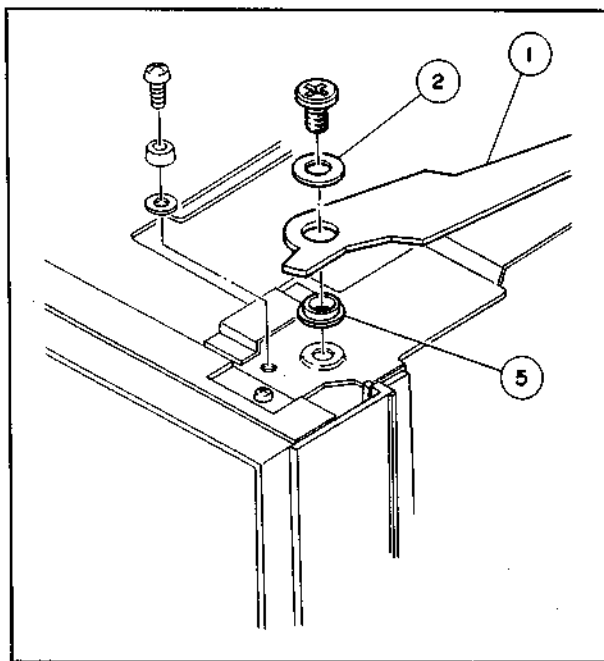
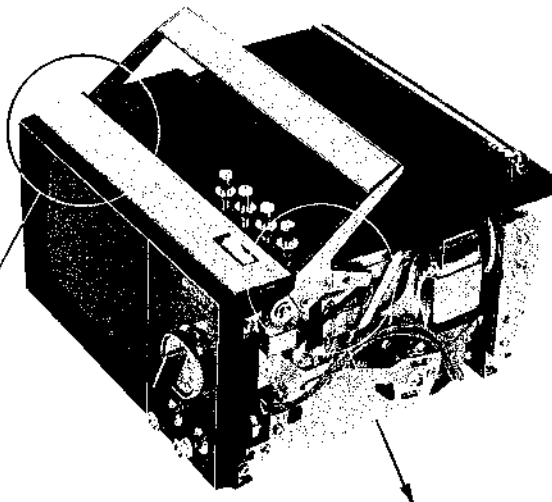

HANDLE MECHANISM PARTS

Ref. No.	Part No.	Description
1	X-40090-31-1	Handle Ass'y
2	4-009-035-01	Washer
3	4-009-033-01	Spacer
4	4-009-034-01	Special Washer
5	4-009-032-01	Collar

SONY CORPORATION

Printed in Japan



Complete Spare Parts List for TV-500UET

Nov. 10, 1967

<u>Part No.</u>	<u>Description</u>	<u>Q'ty</u>
<u>1. General</u>		
1-463-004-11	UHF Tuner (BT-186) -----	1
98-0119-18	VHF Tuner (BT-431ETu) <i>1-463-035-11</i> -----	1
98-0119-20	Signal Circuit Board (BC) Block, completed ----	1
98-0119-30	Deflection Circuit Board (EF) Block, completed-	1
1-451-003	Deflection Yoke Ass'y -----	1
1-453-019	High Voltage Block Ass'y -----	1

2. Mechanical Parts

2-1. Cabinet & Appearance Block

X-40083-01	Front Cabinet Ass'y -----	1
-03	Carrying Handle Ass'y -----	1
-05	UHF Channel Selecting Knob Ass'y -----	1
-06	Volume Control Knob Ass'y -----	1
-07	Fine Tuning Knob Ass'y -----	1
-08	UHF Dial Drum Ass'y -----	1
-10	Handle Mechanism Ass'y -----	1
-11	Side Panel Ass'y (Right) -----	1
-12	" " " (Left) -----	1
-13	Video IF Shield Case Ass'y -----	1
-18	Front Stand Ass'y -----	1
-19	Upper Ornamental Base Ass'y -----	1
X-40090-01	VHF Channel Selecting Knob Ass'y -----	1
-03	Dial String Ass'y -----	1
-05	Switch Combinating Sub Plate Ass'y -----	1
-06	Condenser Skirt Ass'y -----	1
4-008-321	Cushinn Actuator Plate -----	1
-303	Upper Cabinet -----	1
-330	Picture Tube Protector -----	1
-331	Dial Cover -----	1
-332	Picture Tube Mt'g Ring -----	1
-333	Picture Tube Mt'g Bracket -----	1

<u>Part No.</u>	<u>Description</u>	<u>Q'ty</u>
4-008-334	Speaker Net -----	1
-337	Foot -----	4
-340	Special Screw -----	1
-343	Tuner Mt'g Bracket -----	1
-345	Dial Pointer -----	1
-346	Variable Resistor Mt'g Bracket -----	1
-347	Chassis Power Supply Section -----	1
-348	Clamp Electric Capacitor -----	1
-349	Control Knob -----	4
-351	Main Chassis -----	1
-352	Variable Resistor Mt'g Bracket (Large) -----	1
-353	Heat Shield Plate -----	1
-355	Heat Sink for Horizontal Power Transistor -----	1
-356	Heat Sink for Vertical Power Transistor -----	1
-357	Deflection Circuit Board Mt'g Bracket -----	2
-358	Tuner Shaft Collar -----	1
-359	Pilot Lamp Bracket -----	1
-360	Video IP Shield Case (Print Side) -----	1
-361	Heat Sink for TO-1 -----	1
-371	Short Plate -----	1
-377	Spacer 3 Pole Connector -----	1
-373	UHF Channel Knob Spacer -----	1
-374	Volume Knob Spacer -----	1
-379	Short, foil -----	2
-382	Pulley -----	4
-385	Ornamental Plate, side panel sheet, contact (C) -----	1
4-009-013	Antenna Terminal Mt'g Bracket -----	1
-014	Fuse Holder Mt'g Bracket -----	1
-015	Charging Switch Mt'g Bracket -----	1
-017	UHF Dial Scale Plate -----	1
-018	Name Plate -----	1
-019	Antenna Jack Bushing -----	1
-021	Insulating Plate, chassis -----	1
-005	Micro Switch Mt'g Bracket -----	1
-006	Shaft for Combinating Plate -----	1
-007	Spacer for Micro Switch -----	1
-008	Insulating Plate for Switch -----	1
4-003-055	Grommet -----	2
-220	Picture Tube Ground Spring -----	1
4-004-161	Resistor Bushing -----	2
4-006-270	Charge Switch Lock -----	1
-255	Terminal Pin -----	29

<u>Part No.</u>	<u>Description</u>	<u>Q'ty</u>
4-007-043	Sound IF Shield Case (parts side) -----	1
-044	" " " " (print side) -----	1
-045	Heat Sink for Transistor X262 -----	1
-051	Insulating Fiber for Sound IF Shield -----	1
3-804-510	Speaker Mt'g Spring -----	2
4-405-094	Screw 14φ -----	1
-095	Nut 14φ -----	1

2-2. Carton & Accessories

4-495-171	Instruction Manual -----	1
4-491-001	Tag for Front Foot -----	1
X-40083-15	Warranty Card Ass'y -----	1
X-40090-08	Accessory Ass'y -----	1
X-40090-09	Card Ass'y -----	1
3-813-651	Colored Label -----	3
X-44900-03	Polishing Cloth in Polyethylene Bag -----	1
Y-44017-31	External Antenna Connector EAC-6 Complete -----	1
4-005-537	High Voltage Caution Label -----	1
4-008-365	Packing Carton -----	1
4-008-367	Cushion A Foamed Polystyrene -----	1
4-008-368	" B " " -----	1
4-008-378	Master Carton, 2 sets -----	2
-369	Polyethylene Bag Cabinet -----	1
4-004-143	Serial Number Label -----	1

2-3. Screws, Nuts & Washers

7-621-255-22	Screw Phill P 2 x 4; Separator -----	2
-259-48	" P 2.6x6; Side Panel -----	8
-261-35	" P 3 x 5; Pilot Lamp -----	1
-261-35	" P 3 x 5; Telescopic Antenna -----	2
-261-45	" P 3 x 6; Cushion Actuator Plate --	1
-261-45	" P 3 x 6; Actuator Guide -----	2
-261-45	" P 3 x 6; Front Cabinet -----	8
-261-45	" P 3 x 6; 3 Pole Connector -----	2
-261-45	" P 3 x 6; Deflection Circuit Board-	1
-155-62	" P 2 x 10; Micro Switch -----	2
-261-69	" P 3 x 10; Upper Cabinet -----	2
-72	" P 3 x 12; Deflection Circuit Board-	4

<u>Part No.</u>	<u>Description</u>	<u>Q'ty</u>
7-621-261-72	Screw Phill P 3 x 12; UHF Tuner -----	1
-65	" P 3 x 10; Vertical Output Choke Coil	1
-79	" P 3 x 12; Upper Cabinet -----	2
-95	" P 3 x 15; Foot -----	4
-95	" P 3 x 15; VHF Tuner -----	2
-15	" P 3 x 18; Selenium Rectifier -----	1
-15	" P 3 x 18; AC Connector -----	2
-75	" P 3 x 35; Picture Tube Ring Binding	1
-85	" P 3 x 40; Resistor R901 -----	1
-561-45	" K 3 x 6; Carrying Handle -----	2
-45	" K 3 x 6; Upper Cabinet -----	1
-69	" K 3 x 10; Antenna Terminal Mt'g Bracket -----	1
-722-33	Tapping Screw Phill BV 3x5; Vertical Output Choke Coil -----	2
-33	" " " BV 3x5; 3 Lug-3 Pole Terminal -----	1
-48	" " " BV 3x6; Filter Choke Coil for Power Supply -----	2
-48	" " " BV 3x6; High Voltage Block-	1
-48	" " " BV 3x6; Main Chassis -----	2
-48	" " " BV 3x6; Speaker -----	2
-48	" " " BV 3x6; Lug Washer on Upper Cabinet -----	1
-48	" " " BV 3x6; BC Printed Circuit Board -----	3
-48	" " " BV 3x6; Condenser Skirt ---	1
-41	" " " R 3x6; Picture Tube Protector -----	4
-63	" " " (+)BV 3x10; Picture Tube ---	4
-721-87	" " " K 2.6x8; Dial Cover -----	1
7-622-108-01	Nut 3φ Picture Tube Binding -----	1
-108-01	" 3φ Deflection Printed Circuit Board -----	4
-108-01	" 3φ UHF Dial Scale -----	2
7-623-108-12	Washer 3φ Filter Choke Coil for Power Rectifier	2
-12	" 3φ Variable Resistor Mt'g Bracket -----	1
-12	" 3φ 3 Lug-3 Pole -----	1
-12	" 3φ 3φ Vartical Output Choke Coil -----	2
-113-27	" 6φ 0.4t (large) Antenna Jack -----	1
-208-22	Spring Washer 3φ; Tuner -----	3
-22	" " 3φ; AC Connector -----	2
-22	" " 3φ; Pilot Lamp -----	1

<u>Part No.</u>	<u>Description</u>	<u>Q'ty</u>
7-623-208-22	Spring Washer 3ø; Telescopic Antenna -----	2
-305-01	Int. Teeth Washer 2ø; Micro Switch -----	2
-408-01	Ext. Teeth Washer 3ø; Lug Washer -----	2
-01	" 3ø; Selenium Rectifier -----	1
-01	" 3ø; Heat Sink for Vertical Power Transistor -----	4
-01	" 3ø; Heat Sink for Horizontal Power Transistor -----	4
-508-01	Lug Washer 3ø; Main Chassis & Power Supply Chassis -----	2
-508-01	" 3ø; Upper Cabinet -----	1
-508-01	" 3ø; Signal Circuit Board (Lug) -----	1
7-624-108-01	E Type Retainer E-4; Handles Mechanism -----	2
-107-01	" E-3; Pulley Mt'g -----	4
7-628-251-25	Spring Washer Was Screws (+) P 3x6 Volume Control Mt'g Bracket -----	4
-25	" " " " (+) P 3x6 Handles Mechanism Mt'g Bracket -----	4
-25	" " " " (+) P 3x6 Antenna Terminal Mt'g Bracket -----	1
-25	" " " " (+) P 3x6 Heat Shield ----	2
-25	" " " " (+) P 3x6 Power Switch ---	2
-25	" " " " (+) P 3x6 Deflection Circuit Board -----	5
-25	" " " " (+) P 3x6 Charge Switch --	2
-25	" " " " (+) P 3x6 Charge Switch Mt'g Bracket -----	1
-25	" " " " (+) P 3x6 Fuse Holder ----	2
-25	" " " " (+) P 3x6 Fuse Holder Mt'g Bracket -----	1
-25	" " " " (+) P 3x6 Picture Tube ---	2
-25	" " " " (+) F 3x6 Capacitor Clamp Mt'g -----	2

<u>Part No.</u>	<u>Description</u>	<u>Q'ty</u>
-----------------	--------------------	-------------

3. Electrical Parts

A. Semi-conductors

a. Signal Circuit Board (BC) Block

	Transistor	2SC657, X301,302 -----	2
		2SC629, X303 -----	1
		2SB382, X304,305 -----	2
		2SC401, X306 -----	1
		2SC403, X401,402 -----	2
		2SD127, X552 -----	1
		2SB382, X553 -----	1
		2SC401, X551 -----	1
	Diode	1T261, D301 -----	1
		1T22, D302 -----	1
		1T23, D402,403 -----	2
		1T240, D401 -----	1
8-691-001	Thermistor	CS-120, Th-551 -----	1

b. Deflection Circuit Board (EF) Block

	Transistor	2SC470, X501 -----	1
		2SB380, X601 -----	1
		2SD127, X701 -----	1
		2SB382, X702 -----	1
		2SD29, X703 -----	1
		2SB381, X801 -----	1
		2SC756, X802 -----	1
	Diode	1T22, D601,602 -----	2
		S2A30, D802 -----	1
		HF-SD1Z D801 -----	1
		UF-SD1A D803 -----	1
		1T-22A D603 -----	1

B. Coils & Transformer

a. Signal Circuit Board (BC) Block

1-403-498	Video IF Transformer, VIFT-2 -----	1
-----------	---	---

<u>Part No.</u>	<u>Description</u>	<u>Q'ty</u>
1-403-499	Video IF Transformer, VIPT-3 -----	1
-500	" " " , VIPT-4 -----	1
-485	" Detector Block, DET -----	1
-321	Sound IF Transformer, SIFT-2 -----	1
-316	" " " , SIFT-1 -----	1
1-409-036	Sound IF Trap Coil, Trap-3 -----	1
-086	Video IF Trap Coil, Trap-2 -----	1
-087	Video IF Trap Coil, Trap-1 -----	1
1-407-133	RF Choke Coil 1uH L404 -----	1
-177	Micro Inductor 470uH L306 -----	1
-178	Micro Inductor 1uH L401 -----	1
-184	Micro Inductor 3.3uH L301,302,304 -----	3
-187	Micro Inductor 5.6uH L403 -----	1

b. Deflection Circuit Board (EF) Block

1-407-083	Micro Inductor 2.5mH L802 -----	1
-177)	" " 470uH L501 -----	1
-052)		
1-421-013	RF Filter Inductor 20uH L801 -----	1
1-413-012	Horizontal Ringing Coil, HSC -----	1
1-425-348	Horizontal Pulse Trans, HPT -----	1
1-435-008	Vertical Blocking OSC Trans, VBT -----	1
-016	Horizontal OSC Trans, HBT -----	1
1-437-004	Horizontal Drive Trans, HDT -----	1

c. Main Block

1-421-186	Filter Choke for Power Rectifier, BCH -----	1
-201	Vertical Output Choke Coil, VCH -----	1
1-441-364	Power Transformer -----	1

C. Electrical Parts

a. Signal Circuit Board (BC) Block

1-538-609	Printed Circuit Board -----	1
1-221-463	Resistor, adjustable B-500 ohms VR301 -----	1

<u>Part No.</u>	<u>Description</u>	<u>Q'ty</u>
b. <u>Deflection Circuit Board (EF) Block</u>		
1-538-610	Printed Circuit Board -----	1
1-221-475	Adjustable Carbon Resistor 5K-B VR602 -----	1
-871	" " " 3K-B VR702,703 ----	2
-872	" " " 600K-B VR801 -----	1
1-506-108	SV-Pin -----	7
1-526-075	Picture Tube Socket -----	1

c. <u>Main Block</u>		
1-221-276	Variable Resistor T-5K ohms VR-1 -----	1
-297	" " B-10K " VR601 -----	1
-403	" " B-2K " VR701 -----	1
-429	" " B-250K " VR501 -----	1
-709	" " B-1K " VR502 -----	1
1-501-087	Rod Antenna Completed -----	1
1-502-169	Speaker -----	1
1-507-075	Earphone Jack -----	1
-167	Antenna Jack -----	1
-901	Nut for Jack -----	3
1-508-155	3 Pole Connector -----	1
-156-23	Power Plug with Switch -----	1
1-513- 302	Seesaw Switch -----	1
1-519-007	Neon Lamp -----	1
1-531-106	Selenium Rectifier -----	1
1-532-053	Fuse (1.6A)-----	1
1-536-154	3L3 Lug Terminal Board -----	1
X-40033-09	E Terminal with Lead Wire -----	1
1-514-330	Slide Switch -----	1
-332	Micro Switch -----	1
1-533-050	Fuse Holder -----	1
873110520	Picture Tube (GT-496) -----	1

D. Resistors

a. <u>Signal Circuit Board (BC) Block</u>		
1-242-615	Resistor, carbon RD $\frac{1}{2}$ UR 3.9 ohms R559 -----	1
-621	" " " 6.8 " R551 -----	1

<u>Part No.</u>	<u>Description</u>	<u>Q'ty</u>
1-242-625	Resistor, carbon RD $\frac{1}{2}$ UR 10 ohms R301 -----	1
-637	" " " 33 " R303 -----	1
-638	" " " 36 " R302 -----	1
-641	" " " 47 " R413 -----	1
-649	" " " 100 " R313,325,330--	3
-651	" " " 120 " R557 -----	1
-653	" " " 150 " R309,315 -----	2
-656	" " " 200 " R333,402 -----	2
-658	" " " 240 " R556 -----	1
-660	" " " 300 " R305,402 -----	2
-661	" " " 330 " R319 -----	1
-664	" " " 430 " R401,554 -----	2
-666	" " " 510 " R334,307 -----	2
-668	" " " 620 " R555 -----	1
-672	" " " 910 " R321 -----	1
-673	" " " 1K " R304,336,408--	3
-675	" " " 1.2K " R321,312,410--	3
-677	" " " 1.5K " R409 -----	1
-679	" " " 1.8K " R316 -----	1
-682	" " " 2.4K " R331,553 -----	2
-684	" " " 3K " R320 -----	1
-685	" " " 3.3K " R337,403,411, 412 -----	4
-687	" " " 3.9K " R317 -----	1
-689	" " " 4.7K " R329 -----	1
-691	" " " 5.6K " R311 -----	1
-701	" " " 15K " R323,404 -----	2
-704	" " " 20K " R552 -----	1
-712	" " " 43K " R414 -----	1
-714	" " " 51K " R406 -----	1
-692	" " " 6.2K " R415 -----	1
1-244-665	" " RD $\frac{1}{2}$ SR 470 " R405 -----	1
1-207-014	Resistor, wire wound RW $\frac{1}{2}$ RL 2 " R558 -----	1
1-202-113	Resistor, composition RC1/8L 150K " R338 -----	1
1-203-451	Resistor, carbon RD1/16L 3K " R306,310 -----	2/13
-194	" " " 3.3K " R306,310 -----	2/13
-892	" " " 3.6K " R306,310 -----	2/13
-497	" " " 3.9K " R306,310 -----	2/13
-698	" " " 4.3K " R306,310 -----	2/13
-185	" " " 4.7K " R306,310 -----	2/13
-183	" " " 1.5K " R306,310 -----	2/13

<u>Part No.</u>	<u>Description</u>	<u>Q'ty</u>
1-203-184	Resistor, carbon RD1/16L 2.2K ohms R306,310	--- 2/13
-460	" " " 2.7K " R306,310	--- 2/13
-853	" " " 1.2K " R306,310	--- 2/13
1-204-070	" " " 2.4K " R306,310	--- 2/13
-195	" " " 2.0K " R306,310	--- 2/13
-535	" " " 1.8K " R306,310	--- 2/13
-186	" " " 5.6K " R314	----- 1/13
-187	" " " 6.8K " R314	----- 1/13
-188	" " " 7.5K " R314	----- 1/13
-189	" " " 8.2K " R314	----- 1/13
1-204-191	" " " 9.1K " R314	----- 1/13
1-203-190	" " " 10K " R314	----- 1/13
-191	" " " 12K " R314	----- 1/13
-192	" " " 15K " R314	----- 1/13
-891	" " " 22K " R314	----- 1/13
-428	" " " 27K " R314	----- 1/13
1-209-045	" " " 39K " R314	----- 1/13
1-204-192	" " " 47K " R314	----- 1/13
-015	" " " 56K " R314	----- 1/13

b. Deflecti on Circuit Board (EF) Block

1-207-018	Resistor, wire wound RW $\frac{1}{2}$ RL 3 ohms R709,710	-- 2
1-242-642	" , carbon RD $\frac{1}{2}$ UR 51 ohms R601	----- 1
-644	" " " 62 " R503	----- 1
-647	" " " 82 " R606	----- 1
-649	" " " 100 " R803	----- 1
-662	" " " 360 " R612	----- 1
-664	" " " 430 " R613,708	--- 2
-666	" " " 510 " R602,707	--- 2
-669	" " " 680 " R605	----- 1
-673	" " " 1K " R611,808	--- 2
-680	" " " 2K " R705,801	--- 2
-682	" " " 2.4K " R616	----- 1
-683	" " " 2.7K " R610,703,615	3
-688	" " " 4.3K " R607	----- 1
-677	" " " 1.5K " R701	----- 1
-689	" " " 4.7K " R706	----- 1
-690	" " " 5.1K " R504	----- 1
-692	" " " 6.2K " R501,807	--- 2
-693	" " " 6.8K " R608	----- 1

<u>Part No.</u>	<u>Description</u>	<u>Q'ty</u>
1-242-694	Resistor, carbon RD $\frac{1}{2}$ UR 7.5K ohms R614 -----	1
-697	" " " 10K " R603,806 ---	2
-701	" " " 15K " R711,712 ---	2
-727	" " " 180K " R505 -----	1
-732	" " " 300K " R604 -----	1
-740	" " " 620K " R810 -----	1
-672	" " " 910 " R804 -----	1
1-203-032	" " RD $\frac{1}{2}$ L 1K " R609 -----	1
1-207-223	Resistor, wire wound $\frac{1}{2}$ L 0.33 " R506 -----	1/4
-224	" " " 0.39 " R506 -----	1/4
-225	" " " 0.47 " R506 -----	1/4
-064	" " " 0.62 " R506 -----	1/4
1-242-651	Resistor, carbon RD $\frac{1}{2}$ UR 120 " R715 -----	1/9
-658	" " " 240 " R715 -----	1/9
-662	" " " 360 " R715 -----	1/9
-666	" " " 510 " R715 -----	1/9
-669	" " " 680 " R715 -----	1/9
-671	" " " 820 " R715 -----	1/9
-673	" " " 1K " R715 -----	1/9
-675	" " " 1.2K " R715 -----	1/9
-677	" " " 1.5K " R715 -----	1/9
-716	" " " 62K " R502 -----	1/3
-717	" " " 68K " R502 -----	1/3
-718	" " " 75K " R502 -----	1/3
-732	" " " 300K " R814 -----	1
1-207-086	Resistor, wire wound RW $\frac{1}{2}$ RL 2 " R509 -----	1/10
-087	" " " 1 " R509 -----	1/10

c. Main Block

1-202-431	Composition Resistor RC $\frac{1}{2}$ 100K ohms R811,812 -	2
-649	" " RC $\frac{1}{2}$ 1.5M " R813 -----	1
1-207-012	Wire Resistor R901 -----	1
1-244-683	Carbon Resistor RD $\frac{1}{2}$ SR 3.9K ohms R702 -----	1
1-203-018	" " RD $\frac{1}{2}$ L 220 " R560 -----	1
1-242-707	" " RD $\frac{1}{2}$ UR 27K " R101 -----	1

<u>Part No.</u>	<u>Description</u>	<u>Q'ty</u>
<u>E. Capacitors</u>		
<u>a. Signal Circuit Board (BC) Block</u>		
1-101-837	Capacitor, ceramic 0.5PF 50WV C317 -----	1
-951	" " 1PF " C338,402 -----	2
-952	" " 2PF " C310 -----	1
-953	" " 3PF " C306 -----	1
-955	" " 5PF " C301,302,417 -	3
-957	" " 7PF " C418 -----	1
-960	" " 9PF " C339 -----	1
-115	" " 30PF " C409 -----	1
-121	" " 50PF " C403 -----	1
-312	" " 50PF 75WV C556 -----	1
-963	" " 100PF " C340 -----	1
-571	" " 140PF " C410 -----	1
-423	" " 500PF " C411,412 -----	2
-003	" " 0.005uF 50WV C304,305,307,308, 309,311,312,313, 314,316,319,320, 324,329 -----	14
-001	" " 0.001uF " C405 -----	1
-007	" " 0.05uF " C408,413,415--	3
-004	" " 0.01uF " C404,406,419--	3
-044	" " 0.1uF " C557 -----	1
-002	" " 2000PF " C341 -----	1
1-103-280	Capacitor, polystyrene 250PF 125WV C401 -----	1
1-101-951	Capacitor, ceramic 1PF 50WV C407 -----	1/5
-952	" " 2PF " C407 -----	1/5
-953	" " 3PF " C407 -----	1/5
-954	" " 4PF " C407 -----	1/5
-955	" " 5PF " C407 -----	1/5
1-121-230	Capacitor, electrolytic 1uF 25WV C327 -----	1
-232	" " 3uF " C328 -----	1
-104	" " 10uF 6WV C414,551 -----	2
-102	" " 30uF " C315,318,325, 330 -----	4
-135	" " 50uF " C326 -----	1
-111	" " 100uF 3WV C553 -----	1
-121	" " 200uF 12WV C322,554 ---	2
-122	" " 50uF " C552,555 ---	2

<u>Part No.</u>	<u>Description</u>	<u>Q'ty</u>
b. Deflection Circuit Board (EF) Block		
1-101-845	Capacitor, ceramic 1000PF 500WV C818,819	2
1-105-671	Capacitor, mylar 0.0068uF 50WV C604	1
-661	" " 0.001uF " C502	1
-683	" " 0.068uF " C802	1
-292	" " 0.055uF 250WV C807	1
-679	" " 0.033uF 50WV C605,610	2
-753	" " 0.01uF 200WV C809	1
-675	" " 0.015uF 50WV C603,801	2
-689	" " 0.22uF " C803	1
-687	" " 0.15uF " C707	1
-685	" " 0.1uF " C805	1
-274	Capacitor, mylar 0.015uF " C808	1
-041	" " 0.01uF " C708	1
1-113-122	Capacitor, paper 0.05uF 500WV C505	1
-124	" " 0.2uF 150WV C503	1
1-127-091	Capacitor, electrolytic 0.2uF 25WV C601,608	2
1-121-241	" " 3uF " C602	1
-232	" " 3uF " C810	1
-233	" " 5uF " C607,705	2
-246	" " 5uF 150WV C504	1
-104	" " 10uF 6WV C501	1
-249	" " 20uF 10WV C701,704	2
1-131-088	" " 22uF 15WV C703	1
1-121-220	" " 200uF 12WV C806	1
-342	" " 500uF 6WV C706	1
-084	" " 500uF 12WV C702	1
1-105-683	Capacitor, mylar 0.068uF 50WV C804	1/4
-685	" " 0.1uF " C804	1/4
-687	" " 0.15uF " C804	1/4
-689	" " 0.22uF " C804	1/4

c. Main Block

1-113-122	PS Capacitor 0.05uF 500WV C811,812,813, 814	4
1-119-106	Electrolytic Capacitor 100uF 15WV C902	1
1-121-023	" " 4000uF " C903	1
-500	" " 4000uF 25WV C901	1
1-101-044	Ceramic Capacitor 0.1uF 50WV C557	1
1-102-059	" " 2000PF 15KW C904,905	2



ONY CORPORATION

Complete Spare Parts List for TV-500UET (P.T.T.)

<u>Part No.</u>	<u>Description</u>	<u>Q'ty</u>	<u>Unit Price</u>
X-40090-31-1	Carrying Handle -----	1	
4-009-034	Special Washer Carrying Handle -----	1	
4-009-033	Special Carrying Handle -----	1	
4-009-035	Washer Plain Carrying Handle -----	1	
4-009-032	Collar Carrying Handle -----	1	
4-491-003	Supplements -----	1	

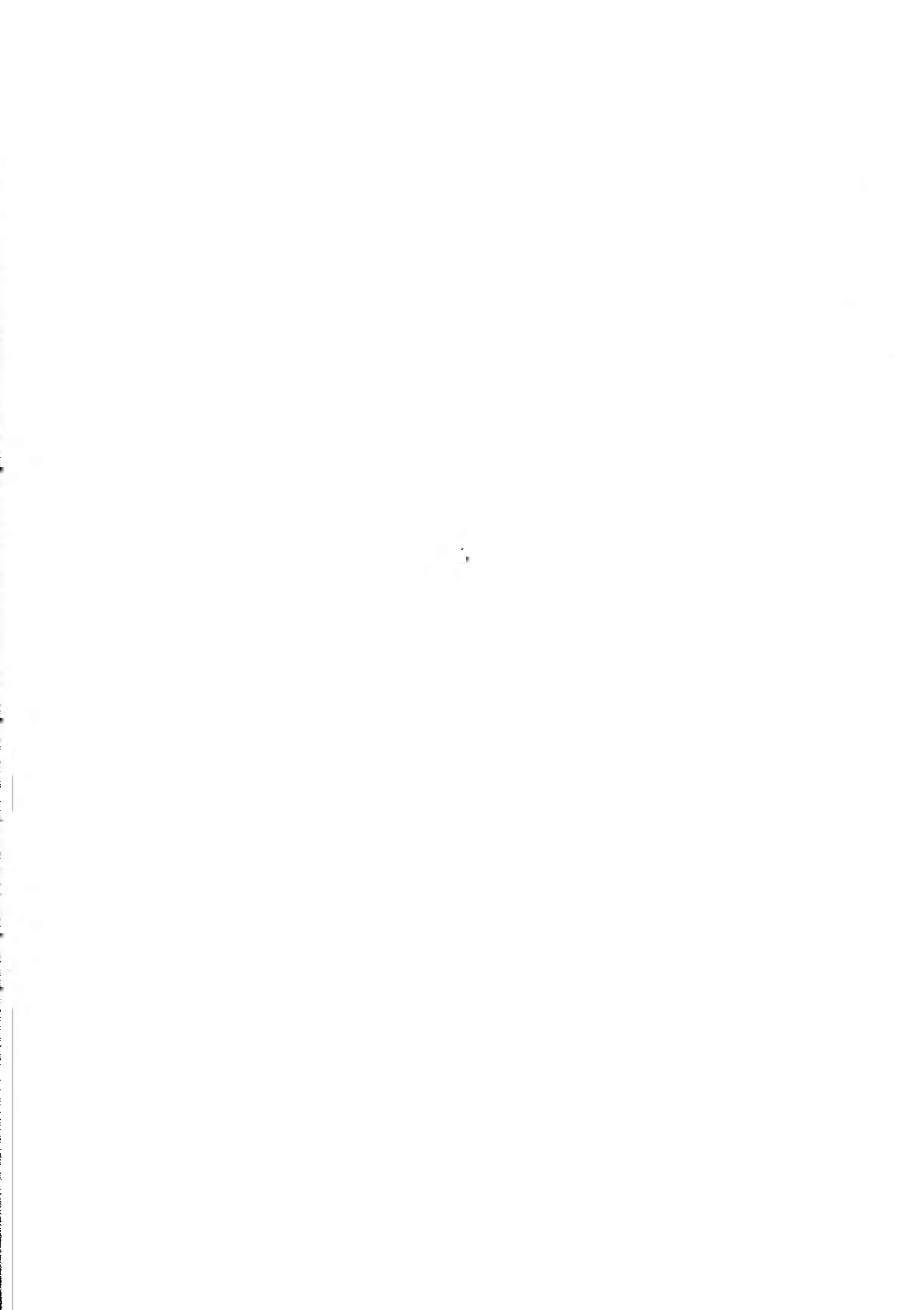

SONY CORPORATION

Complete Spare Parts List for TV-500UET & (P.T.T.)

Nov. 10, 1967

<u>Part No.</u>	<u>Description</u>	<u>Q'ty</u>	<u>Unit Price</u>
<u>1. General</u>			
1-463-004-11	UHF Tuner (BT-186) -----	1	
98-0119-10	VHF Tuner (BT-431ETu) -----	1	
98-0119-20	Signal Circuit Board (BC) Block, completed -----	1	
98-0119-30	Deflection Circuit Board (EF) Block, completed-----	1	
1-451-003	Deflection Yoke Ass'y -----	1	
1-453-019	High Voltage Block Ass'y -----	1	
 <u>2. Mechanical Parts</u>			
<u>2-1. Cabinet & Appearance Block</u>			
X-40083-01	Front Cabinet Ass'y -----	1	
X-40083-05	UHF Channel Selecting Knob Ass'y -----	1	
X-40083-06	Volume Control Knob Ass'y -----	1	
X-40083-07	Fine Tuning Knob Ass'y -----	1	
X-40083-08	UHF Dial Drum Ass'y -----	1	
X-40090-31	Handle Mechanism Ass'y -----	1	
X-40083-11	Side Panel Ass'y (right) -----	1	
X-40083-12	Side Panel Ass'y (left) -----	1	
X-40083-13	Video IF Shield Case Ass'y -----	1	
X-40083-18	Front Stand Ass'y -----	1	
X-40083-19	Upper Ornamental Base Ass'y -----	1	
X-40090-01	VHF Channel Selecting Knob Ass'y -----	1	
X-40090-03	Dial String Ass'y -----	1	
X-40090-05	Switch Combinating Sub Plate Ass'y -----	1	
X-40090-06	Condenser Skirt Ass'y -----	1	
4-008-321	Cushion Actuator Plate -----	1	
4-008-303	Upper Cabinet -----	1	
4-008-330	Picture Tube Protector -----	1	
4-008-331	Dial Cover -----	1	
4-008-332	Picture Tube Mt'g Ring -----	1	
4-008-333	Picture Tube Mt'g Bracket -----	1	
4-009-032	Insulating Spacer -----	1	
4-009-033	Spacer -----	1	
4-009-034	Special Washer -----	1	
4-009-035	Washer -----	1	

<u>Part No.</u>	<u>Description</u>	<u>Q'ty</u>
4-008-334	Speaker Net -----	1
4-008-337	Foot-----	4
4-008-340	Special Screw -----	1
4-008-343	Tuner Mt'g Bracket -----	1
4-008-345	Dial Pointer -----	1
4-008-346	Variable Resistor Mt'g Bracket -----	1
4-008-347	Chassis Power Supply Section -----	1
4-008-348	Clamp Electric Capacitor -----	1
4-008-349	Control Knob -----	4
4-008-351	Main Chassis -----	1
4-008-352	Variable Resistor Mt'g Bracket (large) -----	1
4-008-353	Heat Shield Plate -----	1
4-008-355	Heat Sink for Horizontal Power Transistor -----	1
4-008-356	Heat Sink for Vertical Power Transistor -----	1
4-008-357	Deflection Circuit Board Mt'g Bracket -----	2
4-008-358	Tuner Shaft Collar -----	1
4-008-359	Pilot Lamp Bracket -----	1
4-008-360	Video IF Shield Case (print side) -----	1
4-008-361	Heat Sink for TO-1 -----	1
4-008-371	Short Plate -----	1
4-008-377	Spacer 3 Pole Connector -----	1
4-008-373	UHF Channel Knob Spacer -----	1
4-008-374	Volume Knob Spacer -----	1
4-008-379	Short, foil -----	2
4-008-382	Pulley -----	4
4-009-013	Antenna Terminal Mt'g Bracket -----	1
4-009-014	Fuse Holder Mt'g Bracket -----	1
4-009-015	Charging Switch Mt'g Bracket -----	1
4-009-017	UHF Dial Scale Plate -----	1
4-009-018	Specification Label -----	1
4-009-019	Antenna Jack Bushing -----	1
4-009-021	Insulating Plate, chassis -----	1
4-009-005	Micro Switch Mt'g Bracket -----	1
4-009-006	Shaft for Combinating Plate -----	1
4-009-007	Spacer for Micro Switch -----	1
4-009-008	Insulating Plate for Switch -----	1
4-003-055	Grommet -----	2
4-003-220	Picture Tube Ground Spring -----	1
4-006-270	Charge Switch Lock -----	1
4-006-255	Terminal Pin -----	29
4-007-043	Sound IF Shield Case (parts side) -----	1
4-007-044	Sound IF Shield Case (print side) -----	1

<u>Part No.</u>	<u>Description</u>	<u>Q'ty</u>
4-007-045	Heat Sink for Transistor X262 -----	1
4-007-051	Insulating Fiber for Sound IF Shield -----	1
3-804-510	Speaker Mt'g Spring -----	2
4-405-094	Spring Washer 14ϕ -----	1
4-405-095	Nut 14ϕ -----	1

2-2. Carton & Accessories

4-495-171	Instruction Manual -----	1
4-491-001	Tag for Front Foot -----	1
X-40083-15	Warranty Card Ass'y -----	1
X-40090-08	Accessory Ass'y -----	1
X-40090-09	Card Ass'y -----	1
3-813-651	Colored Label -----	3
X-44900-03	Polishing Cloth in Polyethylene Bag -----	1
Y-44017-31	External Antenna Connector EAC-6 Complete -----	1
4-005-537	High Voltage Caution Label -----	1
4-008-365	Packing Carton -----	1
4-008-367	Cushion A Foamed Polystyrene -----	1
4-008-368	Cushion B Foamed Polystyrene -----	1
4-008-378	Master Carton, 2 sets -----	1/2
4-008-369	Polyethylene Bag Cabinet -----	1
4-004-143	Serial Number Label -----	1
4-419-003	Supplements -----	

2-3. Screws, Nuts & Washers

7-621-255-22	Screw Phill P 2 x 4; Separator -----	2
7-621-259-48	Screw Phill P 2.6 x 6; Side Panel -----	8
7-621-261-35	Screw Phill P 3 x 5; Pilot Lamp -----	1
7-621-261-35	Screw Phill P 3 x 5; Telescopic Antenna -----	2
7-621-261-45	Screw Phill P 3 x 6; Cushion Actuator Plate --	1
7-621-261-45	Screw Phill P 3 x 6; Actuator Guide -----	2
7-621-261-45	Screw Phill P 3 x 6; Front Cabinet -----	8
7-621-261-45	Screw Phill P 3 x 6; 3 Pole Connector -----	2
7-621-261-45	Screw Phill P 3 x 6; Deflection Circuit Board-	1
7-621-155-62	Screw Phill P 2 x 10; Micro Switch -----	2
7-621-261-69	Screw Phill P 3 x 10; Upper Cabinet -----	2
7-621-261-72	Screw Phill P 3 x 12; Deflection Circuit Board-	4
7-621-621-72	Screw Phill P 3 x 12; UHF Tuner -----	1

<u>Part No.</u>	<u>Description</u>	<u>Q'ty</u>
7-621-261-65	Screw Phill P 3 x 10; Vertical Output Choke Coil	1
7-621-261-79	Screw Phill P 3 x 12; Upper Cabinet -----	2
7-621-261-95	Screw Phill P 3 x 15; Foot -----	4
7-621-261-95	Screw Phill P 3 x 15; VHF Tuner -----	2
7-621-262-15	Screw Phill P 3 x 18; Selenium Rectifier -----	1
7-621-262-15	Screw Phill P 3 x 18; AC Connector -----	2
7-621-262-75	Screw Phill P 3 x 35; Picture Tube Ring Binding	1
7-621-262-85	Screw Phill P 3 x 40; Resistor R901 -----	1
7-621-561-45	Screw Phill K 3 x 6; Carrying Handle -----	2
7-621-561-45	Screw Phill K 3 x 6; Upper Cabinet -----	1
7-621-561-69	Screw Phill K 3 x 10; Ant Terminal Mt'g Bracket	1
7-621-722-33	Tapping Screw Phill BV 3 x 5; Vertical Output Choke Coil -----	2
7-621-722-33	Tapping Screw Phill BV 3 x 5; Lug-3 Pole Terminal -----	1
7-621-722-48	Tapping Screw Phill BV 3 x 6; Filter Choke Coil for Power Supply-	2
7-621-722-48	Tapping Screw Phill BV 3 x 6; High Voltage Block -----	1
7-621-722-48	Tapping Screw Phill BV 3 x 6; Main Chassis ----	2
7-621-722-48	Tapping Screw Phill BV 3 x 6; Speaker -----	2
7-621-722-48	Tapping Screw Phill BV 3 x 6; Lug Washer on Upper Cabinet ---	1
7-621-722-51	Tapping Screw Phill BV 3 x 8; BC Printed Circuit Board -----	3
7-621-722-48	Tapping Screw Phill BV 3 x 6; Condenser Skirt -	1
7-621-722-41	Tapping Screw Phill R 3 x 6; Picture Tube Protector -----	4
7-621-722-63	Tapping Screw Phill (+) BV 3 x 10; Picture Tube	4
7-621-721-87	Tapping Screw Phill K 2.6 x 8; Dial Cover ----	1
7-622-108-01	Nut 3/8 Picture Tube Binding -----	1
7-622-108-01	Nut 3/8 Deflection Printed Circuit Board -----	4
7-622-108-01	Nut 3/8 UHF Dial Scale -----	2
7-623-108-12	Washer 3/8 Filter Choke Coil for Power Rectifier -----	2
7-623-108-12	Washer 3/8 Variable Resistor Mt'g Bracket -----	1
7-623-108-12	Washer 3/8 3 Lug-3 Pole -----	1
7-623-108-12	Washer 3/8 Vertical Output Choke Coil -----	2
7-623-113-27	Washer 6/8 0.4t (large) Antenna Jack -----	1
7-623-208-22	Spring Washer 3/8; Tuner -----	3
7-623-208-22	Spring Washer 3/8; AC Connector -----	2
7-623-208-22	Spring Washer 3/8; Pilot Lamp -----	1
7-623-909-01	Washer, fiber 3.5/8 -----	4

<u>Part No.</u>	<u>Description</u>	<u>Q'ty</u>
7-623-208-22	Spring Washer 3ø; Telescopic Antenna -----	2
7-623-305-01	Int. Teeth Washer 2ø; Micro Switch -----	2
7-623-408-01	Ext. Teeth Washer 3ø; Lug Washer -----	2
7-623-408-01	Ext. Teeth Washer 3ø; Selenium Rectifier -----	1
7-623-408-01	Ext. Teeth Washer 3ø; Heat Sink for Vertical Power Transistor -----	4
7-623-408-01	Ext. Teeth Washer 3ø; Heat Sink for Horizontal Power Transistor -----	4
7-623-508-01	Lug Washer 3ø; Main Chassis & Power Supply Chassis -----	2
7-623-508-01	Lug Washer 3ø; Upper Cabinet -----	1
7-623-508-01	Lug Washer 3ø; Signal Circuit Board (Lug) -----	1
7-624-108-01	E Type Retainer E-4; Handles Mechanism -----	2
7-624-107-01	E Type Retainer E-3; Pulley Mt'g -----	4
7-628-251-25	Spring Washer Was Screws (+) P 3 x 6 Volume Control Mt'g Bracket -----	4
7-628-251-25	Spring Washer Was Screws (+) P 3 x 6 Handles Mechanism Mt'g Bracket -----	4
7-628-251-25	Spring Washer Was Screws (+) P 3 x 6 Antenna Terminal Mt'g Bracket -----	1
7-628-251-25	Spring Washer Was Screws (+) P 3 x 6 Heat Shield -----	2
7-628-251-25	Spring Washer Was Screws (+) P 3 x 6 Power Switch -----	2
7-628-251-25	Spring Washer Was Screws (+) P 3 x 6 Deflection Circuit Board -	5
7-628-251-25	Spring Washer Was Screws (+) P 3 x 6 Charge Switch -----	2
7-628-251-25	Spring Washer Was Screws (+) P 3 x 6 Charge Switch Mt'g Bracket -----	1
7-628-251-25	Spring Washer Was Screws (+) P 3 x 6 Fuse Holder -----	2
7-628-251-25	Spring Washer Was Screws (+) P 3 x 6 Fuse Holder Mt'g Bracket -----	1
7-628-251-25	Spring Washer Was Screws (+) P 3 x 6 Picture Tube -----	2
7-628-251-25	Spring Washer Was Screws (+) P 3 x 6 Capacitor Clamp Mt'g -----	2

<u>Part No.</u>	<u>Description</u>	<u>Q'ty</u>
-----------------	--------------------	-------------

3. Electrical Parts

A. Semi-conductors

a. Signal Circuit Board (BC) Block

	Transistor	2SC657, X301,302 -----	2	
		2SC629, X303 -----	1	
		2SB382, X304,305 -----	2	
		2SC402A, X306 -----	1	
		2SC403, X401,402 -----	2	
		2SD127, X552 -----	1	
		2SB382, X553 -----	1	
		2SC401, X551 -----	1	
		Diode	1T261, D301 -----	1
			1T22, D302 -----	1
			1T23, D402,403 -----	2
			1T240, D401 -----	1
		8-691-001	Thermistor	CS-120, Th-551 -----

b. Deflection Circuit Board (EF) Block

	Transistor	2SC470, X501 -----	1	
		2SA202, X601 (Ser. No. up to 11,500)-	1	
		2SA202, X601 (Ser. No. 11,501 and later)	1	
		2SD127, X701 -----	1	
		2SB382, X702 -----	1	
		2SD29, X703 -----	1	
		2SB381, X801 -----	1	
		2SC756, X802 -----	1	
		Diode	1T22, D601, 602 -----	2
			S2A30, D802 -----	1
HF-SD1Z D801 -----	1			
UF-SD1A D803 -----	1			
		1T-22A D603 -----	1	

B. Coils & Transformer

a. Signal Circuit Board (BC) Block

1-403-498	Video IF Transformer, VIFT-2 -----	1
-----------	------------------------------------	---

<u>Part No.</u>	<u>Description</u>	<u>Q'ty</u>
1-403-499	Video IF Transformer, VIFT-3 -----	1
1-403-500	Video IF Transformer, VIFT-4 -----	1
1-403-485	Video Detector Block, DET -----	1
1-403-321	Sound IF Transformer, SIFT-2 -----	1
1-403-316	Sound IF Transformer, SIFT-1 -----	1
1-409-036	Sound IF Trap Coil, Trap-3 -----	1
1-409-086	Video IF Trap Coil, Trap-2 -----	1
1-409-087	Video IF Trap Coil, Trap-1 -----	1
1-407-133	RF Choke Coil 1 μ H L404 -----	1
1-407-177	Micro Inductor 470 μ H L306 -----	1
1-407-178	Micro Inductor 1 μ H L401 -----	1
1-407-184	Micro Inductor 3.3 μ H L301,302,304 -----	3
1-407-187	Micro Inductor 5.6 μ H L403 -----	1

b. Deflection Circuit Board (EF) Block

1-407-083	Micro Inductor 2.5mH L802 -----	1
1-407-177)	Micro Inductor 470 μ H L501 -----	1
1-407-052)		
1-421-013	RF Filter Inductor 20 μ H L801 -----	1
1-413-012	Horizontal Ringing Coil, HSC -----	1
1-425-348	Horizontal Pulse Trans, HPT -----	1
1-435-008	Vertical Blocking OSC Trans, VBT -----	1
1-435-016	Horizontal OSC Trans, HBT -----	1
1-437-004	Horizontal Drive Trans, HDT -----	1

c. Main Block

1-421-186	Filter Choke for Power Rectifier, BCH -----	1
1-421-201	Vertical Output Choke Coil, VCH -----	1
1-441-364	Power Transformer -----	1

C. Electrical Parts

a. Signal Circuit Board (BC) Block

1-538-609	Printed Circuit Board -----	1
1-221-463	Resistor, adjustable B-500 Ω VR301 -----	1

<u>Part No.</u>	<u>Description</u>	<u>Q'ty</u>
b. <u>Deflection Circuit Board (EF) Block</u>		
1-538-610	Printed Circuit Board -----	1
1-221-475	Adjustable Carbon Resistor 5k-B VR602 -----	1
1-221-871	Adjustable Carbon Resistor 3k-B VR702,703 -----	2
1-221-872	Adjustable Carbon Resistor 600k-B VR801 -----	1
1-506-108	SV-Pin -----	7
1-526-084	Picture Tube Socket -----	1

c. <u>Main Block</u>		
1-221-276	Variable Resistor T-5kΩ VR-1 -----	1
1-221-297	Variable Resistor B-10kΩ VR601 -----	1
1-221-403	Variable Resistor B-2kΩ VR701 -----	1
1-221-429	Variable Resistor B-250kΩ VR501 -----	1
1-221-709	Variable Resistor B-1kΩ VR502 -----	1
1-501-087	Telescopic Antenna Completed -----	1
1-502-169	Speaker -----	1
15-07-075	Earphone Jack -----	1
1-507-167	Antenna Jack -----	1
1-507-901	Nut for Jack -----	3
1-508-155	3 Pole Connector -----	1
1-508-156-23	Power Plug with Switch -----	1
1-514-331	Seesaw Switch -----	1
1-519-007	Neon Lamp -----	1
1-531-106	Selenium Rectifier -----	1
1-532-053	Fuse (1.6A) -----	1
1-536-154	3L3 Lug Terminal Board -----	2
1-514-330	Slide Switch -----	1
1-514-332	Micro Switch -----	1
1-533-050	Fuse Holder -----	1
873110520	Picture Tube (CT-496) -----	1
1-417-020	U-V Separator Ass'y -----	1
1-534-379	IF Output Cable -----	1

D. Resistors

a. <u>Signal Circuit Board (BC) Block</u>		
1-242-615	Resistor, carbon RD1/4UR 3.9Ω R559 -----	1
1-242-621	Resistor, carbon RD1/4UR 6.8Ω R551 -----	1

<u>Part No.</u>	<u>Description</u>	<u>Q'ty</u>
1-242-625	Resistor, carbon RD1/4UR 10Ω R301 -----	1
1-242-637	Resistor, carbon RD1/4UR 33Ω R303 -----	1
1-242-638	Resistor, carbon RD1/4UR 36Ω R302 -----	1
1-242-641	Resistor, carbon RD1/4UR 47Ω R413 -----	1
1-242-649	Resistor, carbon RD1/4UR 100Ω R313,325,330 ----	3
1-242-651	Resistor, carbon RD1/4UR 120Ω R557 -----	1
1-242-653	Resistor, carbon RD1/4UR 150Ω R309,315 -----	2
1-242-656	Resistor, carbon RD1/4UR 200Ω R333,402 -----	2
1-242-658	Resistor, carbon RD1/4UR 240Ω R556 -----	1
1-242-660	Resistor, carbon RD1/4UR 300Ω R305,402 -----	2
1-242-661	Resistor, carbon RD1/4UR 330Ω R319 -----	1
1-242-663	Resistor, carbon RD1/4UR 390Ω R318 -----	1
1-242-664	Resistor, carbon RD1/4UR 430Ω R401,554 -----	2
1-242-666	Resistor, carbon RD1/4UR 510Ω R334,307 -----	2
1-242-668	Resistor, carbon RD1/4UR 620Ω R555,407 -----	2
1-242-673	Resistor, carbon RD1/4UR 1kΩ R304,336,408 ----	3
1-242-675	Resistor, carbon RD1/4UR 1.2kΩ R321,312,410 ---	3
1-242-677	Resistor, carbon RD1/4UR 1.5kΩ R409 -----	1
1-242-679	Resistor, carbon RD1/4IR 1.8kΩ R316 -----	1
1-242-682	Resistor, carbon RD1/4UR 2.4kΩ R331,553 -----	2
1-242-684	Resistor, carbon RD1/4UR 3kΩ R320 -----	1
1-242-685	Resistor, carbon RD1/4UR 3.3kΩ R337,403,411,412	4
1-242-687	Resistor, carbon RD1/4UR 3.9kΩ R317 -----	1
1-242-689	Resistor, carbon RD1/4UR 4.7kΩ R329 -----	1
1-242-691	Resistor, carbon RD1/4UR 5.6kΩ R311 -----	1
1-242-701	Resistor, carbon RD1/4UR 15kΩ R323,404 -----	2
1-242-704	Resistor, carbon RD1/4UR 20kΩ R552,406 -----	2
1-242-712	Resistor, carbon RD1/4UR 43kΩ R414 -----	1
1-242-714	Resistor, carbon RD1/4UR 51kΩ R406 -----	1
1-242-692	Resistor, carbon RD1/4UR 6.2kΩ R415 -----	1
1-244-665	Resistor, carbon RD1/4SR 470Ω R405 -----	1
1-207-014	Resistor, wire wound RW1/4RL 2Ω R558 -----	1
1-202-113	Resistor, composition RC1/8L 150Ω R338 -----	1
1-203-451	Resistor, carbon RD1/16L 3kΩ R306,310 -----	2/14
1-203-194	Resistor, carbon RD1/16L 3.3kΩ R306,310 -----	2/14
1-203-892	Resistor, carbon RD1/16L 3.6kΩ R306,310 -----	2/14
1-203-497	Resistor, carbon RD1/16L 3.9kΩ R306,310 -----	2/14
1-203-698	Resistor, carbon RD1/16L 4.3kΩ R306,310 -----	2/14
1-203-185	Resistor, carbon RD1/16L 4.7kΩ R306,310 -----	2/14
1-203-183	Resistor, carbon RD1/16L 1.5kΩ R306,310 -----	2/14
1-203-184	Resistor, carbon RD1/16L 2.2kΩ R306,310 -----	2/14
1-203-460	Resistor, carbon RD1/16L 2.7kΩ R306,310 -----	2/14

<u>Part No.</u>	<u>Description</u>	<u>Q'ty</u>
1-203-853	Resistor, carbon RD1/16L 1.2k Ω R306,310 -----	2/14
1-203-182	Resistor, carbon RD1/16L 1.0k Ω R306,310 -----	2/14
1-204-070	Resistor, carbon RD1/16L 2.4k Ω R306,310 -----	2/14
1-204-195	Resistor, carbon RD1/16L 2.0k Ω R306,310 -----	2/14
1-204-535	Resistor, carbon RD1/16L 1.8k Ω R306,310 -----	2/14
1-204-186	Resistor, carbon RD1/16L 5.6k Ω R314 -----	1/13
1-204-187	Resistor, carbon RD1/16L 6.8k Ω R314 -----	1/13
1-204-188	Resistor, carbon RD1/16L 7.5k Ω R314 -----	1/13
1-204-189	Resistor, carbon RD1/16L 8.2k Ω R314 -----	1/13
1-204-191	Resistor, carbon RD1/16L 9.1k Ω R314 -----	1/13
1-203-190	Resistor, carbon RD1/16L 10k Ω R314 -----	1/13
1-203-191	Resistor, carbon RD1/16L 12k Ω R314 -----	1/13
1-203-192	Resistor, carbon RD1/16L 15k Ω R314 -----	1/13
1-203-891	Resistor, carbon RD1/16L 22k Ω R314 -----	1/13
1-203-428	Resistor, carbon RD1/16L 27k Ω R314 -----	1/13
1-209-045	Resistor, carbon RD1/16L 39k Ω R314 -----	1/13
1-204-192	Resistor, carbon RD1/16L 47k Ω R314 -----	1/13
1-204-015	Resistor, carbon RD1/16L 56k Ω R314 -----	1/13

b. Deflection Circuit Board (EF) Block

1-207-018	Resistor, wire wound RW1/4RL 3 Ω R709,710 -----	2
1-242-642	Resistor, carbon RD1/4UR 51 Ω R601 -----	1
1-242-644	Resistor, carbon RD1/4UR 62 Ω R503 -----	1
1-242-647	Resistor, carbon RD1/4UR 82 Ω R606 -----	1
1-242-649	Resistor, carbon RD1/4UR 100 Ω R803 -----	1
1-242-662	Resistor, carbon RD1/4UR 360 Ω R612 -----	1
1-242-664	Resistor, carbon RD1/4UR 430 Ω R613,708 -----	2
1-242-666	Resistor, carbon RD1/4UR 510 Ω R602,707 -----	2
1-242-669	Resistor, carbon RD1/4UR 680 Ω R605 -----	1
1-242-672	Resistor, carbon RD1/4UR 910 Ω R804 -----	1
1-242-673	Resistor, carbon RD1/4UR 1k Ω R611,808 -----	2
1-242-680	Resistor, carbon RD1/4UR 2k Ω R705,801,616 --	3
1-242-682	Resistor, carbon RD1/4UR 2.4k Ω R704 -----	1
1-242-683	Resistor, carbon RD1/4UR 2.7k Ω R610,703,615 --	3
1-242-688	Resistor, carbon RD1/4UR 4.3k Ω R607 -----	1
1-242-677	Resistor, carbon RD1/4UR 1.5k Ω R701 -----	1
1-242-689	Resistor, carbon RD1/4UR 4.7k Ω R706 -----	1
1-242-690	Resistor, carbon RD1/4UR 5.1k Ω R504 -----	1
1-242-692	Resistor, carbon RD1/4UR 6.2k Ω R501,807 -----	2
1-242-693	Resistor, carbon RD1/4UR 6.8k Ω R608 -----	1

<u>Part No.</u>	<u>Description</u>	<u>Q'ty</u>
1-242-694	Resistor, carbon RD1/4UR 7.5kΩ R614 -----	1
1-242-697	Resistor, carbon RD1/4UR 10kΩ R603,806 -----	2
1-242-701	Resistor, carbon RD1/4UR 15kΩ R711,712 -----	2
1-242-731	Resistor, carbon RD1/4UR 270kΩ R505 -----	1
1-242-732	Resistor, carbon RD1/4UR 300kΩ R604,814 -----	2
1-242-740	Resistor, carbon RD1/4UR 620kΩ R810 -----	1
1-242-672	Resistor, carbon RD1/4UR 910Ω R804 -----	1
1-203-032	Resistor, carbon RD1/2L 1kΩ R609 -----	1
1-207-223	Resistor, wire wound 1/4L 0.33Ω R506 -----	1/5
1-207-224	Resistor, wire wound 1/4L 0.39Ω R506 -----	1/5
1-207-225	Resistor, wire wound 1/4L 0.47Ω R506 -----	1/5
1-207-064	Resistor, wire wound 1/4L 0.62Ω R506 -----	1/5
1-207-058	Resistor, wire wound 1/4L 0.5Ω R506 -----	1/5
1-242-651	Resistor, wire wound 1/4L 120Ω R715 -----	1/9
1-242-658	Resistor, wire wound 1/4L 240Ω R715 -----	1/9
1-242-662	Resistor, wire wound 1/4L 360Ω R715 -----	1/9
1-242-666	Resistor, wire wound 1/4L 510Ω R715 -----	1/9
1-242-669	Resistor, wire wound 1/4L 680Ω R715 -----	1/9
1-242-671	Resistor, wire wound 1/4L 820Ω R715 -----	1/9
1-242-673	Resistor, wire wound 1/4L 1kΩ R715 -----	1/9
1-242-675	Resistor, wire wound 1/4L 1.2kΩ R715 -----	1/9
1-242-677	Resistor, wire wound 1/4L 1.5kΩ R715 -----	1/9
1-242-716	Resistor, wire wound 1/4L 62kΩ R502 -----	1/3
1-242-717	Resistor, wire wound 1/4L 68kΩ R502 -----	1/3
1-242-718	Resistor, wire wound 1/4L 75kΩ R502 -----	1/3
1-207-086	Resistor, wire wound RW1/2RL 2Ω R509 -----	1/5
1-207-087	Resistor, wire wound RW1/2RL 1Ω R509 -----	1/5

c. Main Block

1-202-431	Composition Resistor RC1/4 100kΩ R811,812 -----	2
1-202-649	Composition Resistor RC1/2 1.5MΩ R813 -----	1
1-207-012	Wire Resistor R901 -----	1
1-244-683	Carbon Resistor RD1/4SR 2.7kΩ R702 -----	1
1-203-018	Carbon Resistor RD1/4L 220Ω R560 -----	1
1-242-707	Carbon Resistor RD1/4UR 27kΩ R101 -----	1

<u>Part No.</u>	<u>Description</u>	<u>Q'ty</u>
E. <u>Capacitors</u>		
a. <u>Signal Circuit Board (BC) Block</u>		
1-101-837	Capacitor, ceramic 0.5pF 50WV C317	1
1-101-951	Capacitor, ceramic 1pF 50WV C402	1
1-101-952	Capacitor, ceramic 2pF 50WV C310	1
1-101-953	Capacitor, ceramic 3pF 50WV C306	1
1-101-955	Capacitor, ceramic 5pF 50WV C301,302,417-	3
1-101-957	Capacitor, ceramic 7pF 50WV C418	1
1-101-960	Capacitor, ceramic 9pF 50WV C339	1
1-101-115	Capacitor, ceramic 30pF 50WV C409	1
1-101-121	Capacitor, ceramic 50pF 50WV C403	1
1-101-312	Capacitor, ceramic 50pF 75WV C556	1
1-101-963	Capacitor, ceramic 100pF 75WV C340	1
1-101-571	Capacitor, ceramic 140pF 75WV C416	1
1-101-423	Capacitor, ceramic 500pF 75WV C411,412	2
1-101-003	Capacitor, ceramic 0.005μF 50WV C304,305,307, 308,309,311, 312,313,314, 316,319,320, 324,329	14
1-101-001	Capacitor, ceramic 0.001μF 50WV C405	1
1-101-007	Capacitor, ceramic 0.05μF 50WV C408,413,415-	3
1-101-004	Capacitor, ceramic 0.01μF 50WV C404,406,419-	3
1-101-044	Capacitor, ceramic 0.1μF 50WV C557	1
1-101-002	Capacitor, ceramic 2000pF 50WV C341	1
1-101-058	Capacitor, ceramic 0.05μF 50WV C358	1
1-103-280	Capacitor, polystyrene 250pF 125WV C401	1/5
1-101-951	Capacitor, ceramic 1pF 50WV C407	1/5
1-101-952	Capacitor, ceramic 2pF 50WV C407	1/5
1-101-953	Capacitor, ceramic 3pF 50WV C407	1/5
1-101-954	Capacitor, ceramic 4pF 50WV C407	1/5
1-101-955	Capacitor, ceramic 5pF 50WV C407	1/5
1-127-094	Capacitor, electrolytic 1μF 25WV C327	1
1-121-717	Capacitor, electrolytic 3μF 25WV C328	1
1-121-104	Capacitor, electrolytic 10μF 6WV C414,551	2
1-121-102	Capacitor, electrolytic 30μF 6WV C315,318,325, 330	4
1-121-135	Capacitor, electrolytic 50μF 6WV C326	1
1-121-111	Capacitor, electrolytic 100μF 3WV C553	1
1-121-121	Capacitor, electrolytic 200μF 12WV C322,554	2
1-121-122	Capacitor, electrolytic 50μF 12WV C552,555	2
1-101-058	Capacitor, ceramic 0.005μF ±20% 50WV C558	1

<u>Part No.</u>	<u>Description</u>	<u>Q'ty</u>
b. <u>Deflection Circuit Board (EF) Block</u>		
1-101-845	Capacitor, ceramic 1000pF 500WV	C818,819 ---- 2
1-105-671	Capacitor, mylar 0.0068μF 50WV	C604 ----- 1
1-105-661	Capacitor, mylar 0.001μF 50WV	C502 ----- 1
1-105-683	Capacitor, mylar 0.068μF 50WV	C802,609 ---- 2
1-105-292	Capacitor, mylar 0.055μF 250WV	C807 ----- 1
1-105-679	Capacitor, mylar 0.033μF 50WV	C605,610 ---- 2
1-105-753	Capacitor, mylar 0.01μF 200WV	C809 ----- 1
1-105-675	Capacitor, mylar 0.015μF 50WV	C603,801 ---- 2
1-105-689	Capacitor, mylar 0.22μF 50WV	C803 ----- 1
1-105-687	Capacitor, mylar 0.15μF 50WV	C707 ----- 1
1-105-685	Capacitor, mylar 0.1μF 50WV	C805 ----- 1
1-105-274	Capacitor, mylar 0.015μF 50WV	C808 ----- 1
1-105-041	Capacitor, mylar 0.01μF 50WV	C708 ----- 1
1-113-122	Capacitor, paper 0.05μF 500WV	C505 ----- 1
1-113-124	Capacitor, paper 0.2μF 150WV	C503 ----- 1
1-127-091	Capacitor, electrolytic 0.2μF 25WV	C601,608 --- 2
1-121-241	Capacitor, electrolytic 3μF 25WV	C602 ----- 1
1-121-717	Capacitor, electrolytic 3μF 50WV	C810 ----- 1
1-121-718	Capacitor, electrolytic 5μF 50WV	C607,705 ---- 2
1-121-246	Capacitor, electrolytic 5μF 150WV	C504 ----- 1
1-121-104	Capacitor, electrolytic 10μF 6WV	C501 ----- 1
1-121-249	Capacitor, electrolytic 20μF 10WV	C701,704 ---- 2
1-121-701	Capacitor, electrolytic 20μF 25WV	C703 ----- 1
1-121-201	Capacitor, electrolytic 100μF 15WV	C506,606 --- 2
1-121-594	Capacitor, electrolytic 200μF 12WV	C806 ----- 1
1-121-342	Capacitor, electrolytic 500μF 6WV	C706 ----- 1
1-121-084	Capacitor, electrolytic 500μF 12WV	C702 ----- 1
1-105-683	Capacitor, mylar 0.068μF 50WV	C804 ----- 1/4
1-105-685	Capacitor, mylar 0.1μF 50WV	C804 ----- 1/4
1-105-687	Capacitor, mylar 0.15μF 50WV	C804 ----- 1/4
1-105-689	Capacitor, mylar 0.22μF 50WV	C804 ----- 1/4

c. Main Block

1-113-122	PS Capacitor 0.05μF 500WV	C811,812,813, 814 ----- 4
1-119-106	Electrolytic Capacitor 100μF 15WV	C902 ----- 1
1-121-023	Electrolytic Capacitor 4000μF 15WV	C903 ----- 1
1-121-500	Electrolytic Capacitor 4000μF 25WV	C901 ----- 1
1-101-044	Ceramic Capacitor 0.1μF 50WV	C557 ----- 1
1-102-059	Ceramic Capacitor 2000pF 15KW	C904,905 ---- 2



