

# TV5-303E/T

TV5-202E  
TV5-202V



B & W TV

**E:** For Continental Europe (excl. France, Monaco, Italy & CIRT members)    **T:** For Italy

## Specifications

- Picture Tube : 5", 70° Deflection, Aluminized Screen
- Transistor : 25 15 Silicon—including 3 Epitaxial 20 Germanium
- Diode : 20 (including 4 Selenium)
- Channel Coverage : E-2 to E-11 (5-303E), A to H (5-303T)
- Maximum Sensitivity : 10 $\mu$ V (10Vpp at Picture Tube Cathode)
- IF Circuit : 4 Stages with 5 stagger tuned elements  
Video IF 26.75 Mc, Sound IF 21.25 Mc, Bandwidth 3.75 Mc/—3 dB~—6 dB
- Resolution : Vertical 400 lines, Horizontal 300 lines
- Sound System : 5.5 Mc Inter-carrier System  
Power Output Stage OTL System 150 mW.  
Speaker 3", 70 $\Omega$  Voice Coil
- Automatic Control : Pulse-operated AGC, Diode AFC,  
Sync. ANS (Automatic Noise Suppressor)
- Power Requirement : AC 220V, 50c/s, DC 12V Battery (3.5 AH)
- Power Consumption : AC 13W, DC 9.6W (0.8A)
- Dimensions : 7-5/8" (W)  $\times$  4-1/4" (H)  $\times$  7-1/4" (D)
- Weight : 8 lb
- Glare Proofing : Smoked Filter, 70% Transparency



# SONY®

---

# SERVICE MANUAL

## CONTENTS

	Page
Specifications for the SONY Micro-TV 5-303E and 5-303T .....	1
THE SONY MICRO-TV MODEL 5-303E and 5-303T .....	4
GENERAL .....	4
THE TUNER .....	7
SIGNAL CIRCUIT BOARD SECTION .....	9
DEFLECTION CIRCUIT BOARD AND HIGH-VOLTAGE BLOCK SECTIONS .....	11
POWER SUPPLY SECTION .....	14
METHOD OF DISASSEMBLING THE SET .....	15
To Remove the Front Control Panel .....	15
To Remove the Back Cabinet Cover.....	15
To Remove the Telescopic Antenna and the Tuner.....	15
To Remove the Signal Circuit Board.....	16
To Remove the Deflection Circuit Board .....	17
To Remove the Chassis from the Front Panel .....	18
To Remove the Picture Tube.....	19
To Remove the High Voltage Block .....	19
TROUBLE SHOOTING .....	20
Raster .....	20
Video Output and Synchronization .....	22
Sound.....	24

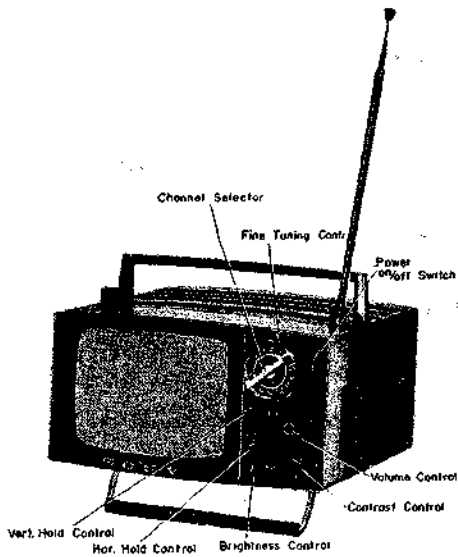

(Fig. 1)

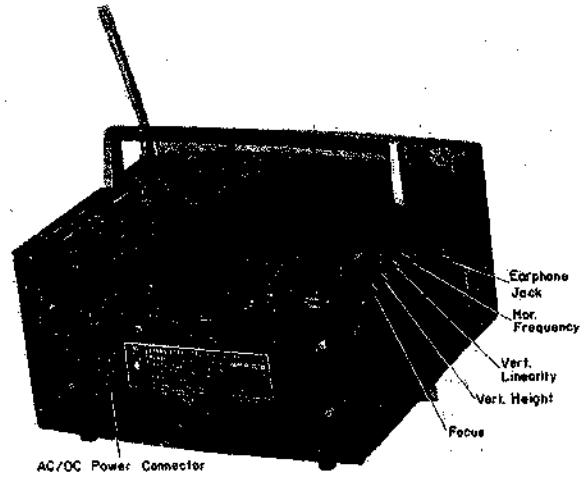

(Fig. 2)

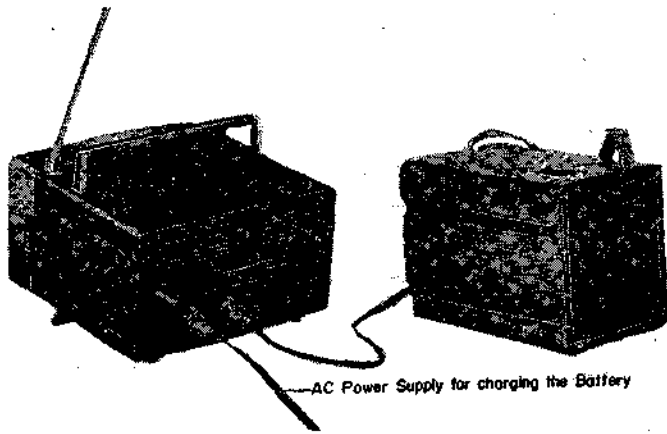

(Fig. 3)

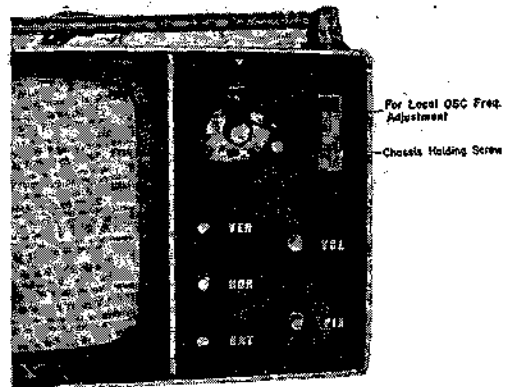

(Fig. 4)

## THE SONY MICRO-TV MODEL 5-303E and 5-303T

### General

The aim in the designing of the SONY Micro-TV Model 5-303E (5-303T) was the creation of a completely new type of TV set which could be achieved only by the use of transistors.

The concrete requirements given to be met from the start of the design were as follows:

- 1) To be small in size and light in weight.
- 2) To have the lowest power consumption of any mass produced TV set.
- 3) To operate perfectly as a completely portable TV set under all conditions.
- 4) To provide facilities for easy servicing.

To fulfil these requirements, many developments and improvements were made on the components and the circuit arrangements as explained below

#### 1. Picture Tube 140CB4 (see Fig. 6)

The resolution of the picture depends greatly upon the construction of the picture tube, and the power consumption of the TV set is much influenced by the construction of the electron gun in the tube. Therefore, the key point of success in making a superior TV set is the improvement of the picture tube. The 140CB4 picture tube was specially developed for the SONY Micro-TV 5-303E (5-303T) and has the following features.

##### a) Resolution

Horizontal 28 lines per cm. (300 lines for full picture)  
Vertical 45 lines per cm. (400 lines for full picture)

##### b) Deflection power

70 degree deflection and a neck diameter of 20 mm (3/4") result in lower deflection power although the anode voltage is as high as 8 KV. This gives a brightness of 500 lux.

##### c) The power required for the heater is less than 1 watt.

##### d) The overall length of tube is only 161mm (6-5/16").

##### e) The cut-off voltage at the first grid is made very low by introducing techniques developed in transistor manufacturing into the assembly of the electron gun. Consequently, satisfactory contrast is obtained at lower video signal output.

##### f) The square corners of the tube give a larger picture for the size of the tube.

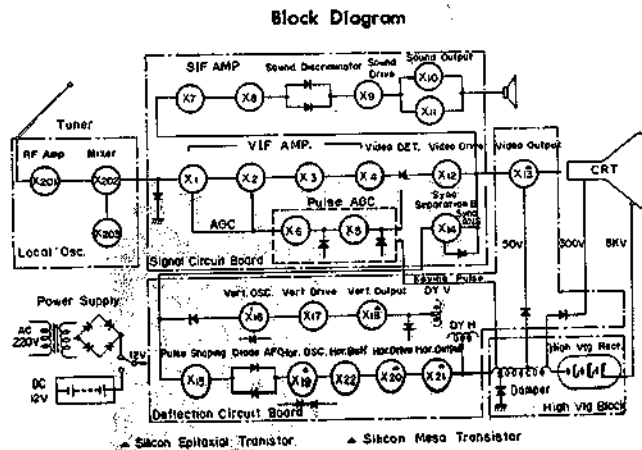

(Fig. 5)

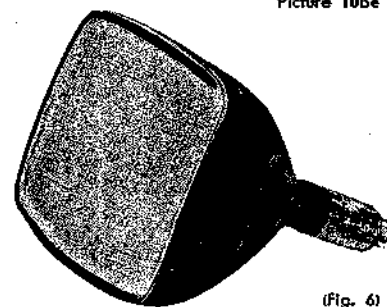

(Fig. 6)

#### Specifications of Picture Tube 140CB4

Type :	Rectangular Frame	Diagonal Dimension :	137 mm (5-3/8")
Neck Diameter :	20 mm (3/4")	Full Length :	161mm (6-5/16")

Deflection :	Electromagnetic	Focusing :	Electrostatic Automatic
Deflection Angle :	70-degree	Ion Trap :	Unnecessary
Heater Voltage :	12.0V, 70 mA	Anode Voltage :	8 KV
Anode Current :	50 $\mu$ A	2nd Grid Voltage :	300 V
Focusing Voltage :	0~120 V	1st Grid Cut-off Voltage :	Approx. -25 V

2. The SONY Epitaxial Transistor 2SC140 (See Fig. 7)

Silicon transistors have been used in high powered circuits in TV sets, such as Video Output Stage, Vertical Output Stage and for the Horizontal Oscillator, Horizontal Drive and Horizontal Output because of their higher working voltage, stable operation at high temperatures and lower  $I_{cbo}$  (Low Leakage Current). The disadvantage has been that the internal resistance (Collector Saturation Resistance,  $R_s$ ) was high (app. 70 $\Omega$ ) causing high power consumption. The new SONY Epitaxial Transistor of the Mesa Silicon Type was developed to overcome this disadvantage. The  $R_s$  of the 2SC140 is 2 $\Omega$ . Three of these special transistors are used in the Micro-TV Model 5-303E (5-303T). One each is used in the Vertical Output, Horizontal Oscillator and Horizontal Drive. One result of the use of these transistors is that the SONY Micro-TV will operate satisfactorily at an ambient temperature of 35°C (95°F).

**Brief Specifications of the SONY Epitaxial Transistor 2SC140**

Maximum Collector-Base Voltage :	60 V
Maximum Collector Current :	1 A
Collector Dissipation (Max) :	1.7 W (without heat sink)
Collector Saturation Resistance ( $R_s$ ) :	2 $\Omega$
Maximum Junction Temperature :	175°C

3. Automatic Gain Control Circuit

The AGC system is of the pulse type and an Automatic Noise Suppression (ANS) circuit is included in the synchronizing pulse separation circuit. With the use of these circuit the SONY Micro-TV 5-303E (5-303T) will maintain synchronization even in a moving car where the signal strength varies suddenly and almost continuously, and even in the presence of strong engine noise radiation.

4. Provision for Easy Servicing

Small size usually means difficult servicing. The SONY Micro-TV Model 5-303E (5-303T) is divided into five sections for easy service. (See the Block Diagram shown in Fig. 5). The sections are: Tuner, Signal Circuit Board, Deflection Circuit Board, High Voltage Block and Power Supply. The Signal Circuit Board and the Deflection Circuit Board are of the Plug-in type so that either of these Boards may be removed as a unit and replaced with a new one for easy and rapid repairing.

Epitaxial Transistor



(Fig. 7)

Level Diagram for Video

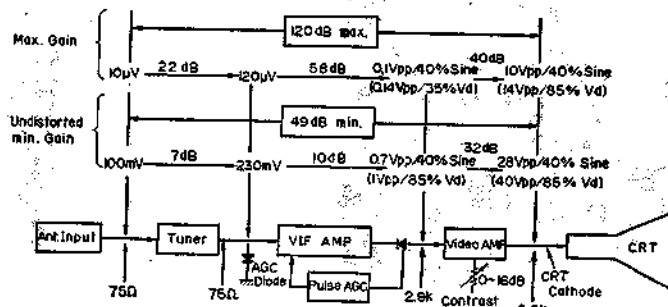

(Fig. 8)

For 5-303E

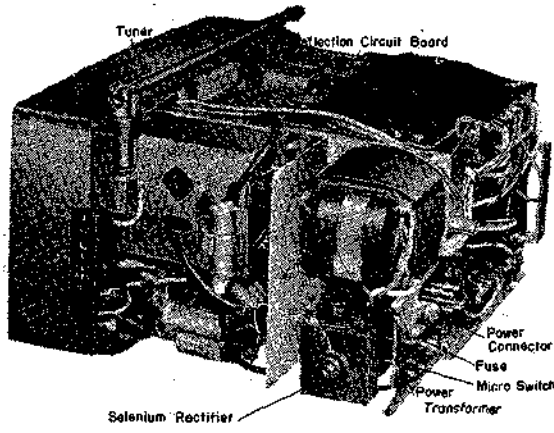

(Fig. 9-1)

For 5-303T

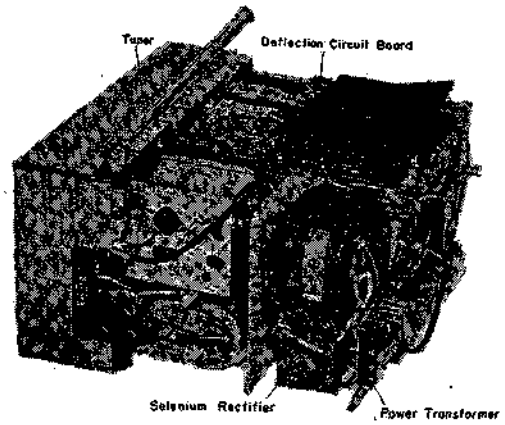

(Fig. 9-2)

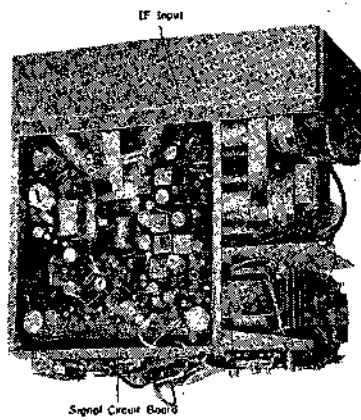

(Fig. 10-1)

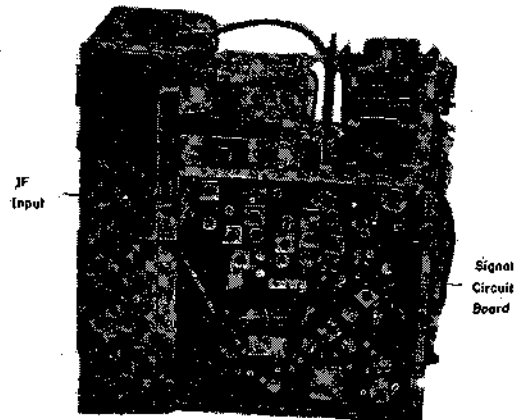

(Fig. 10-2)

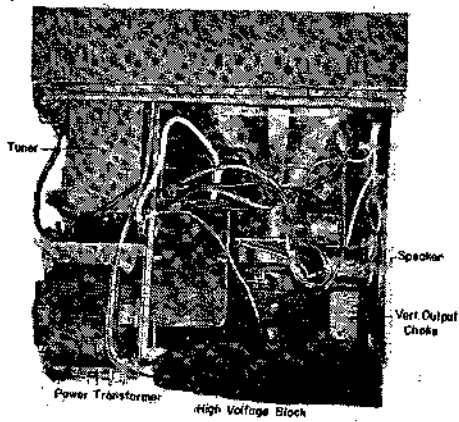

(Fig. 11-1)

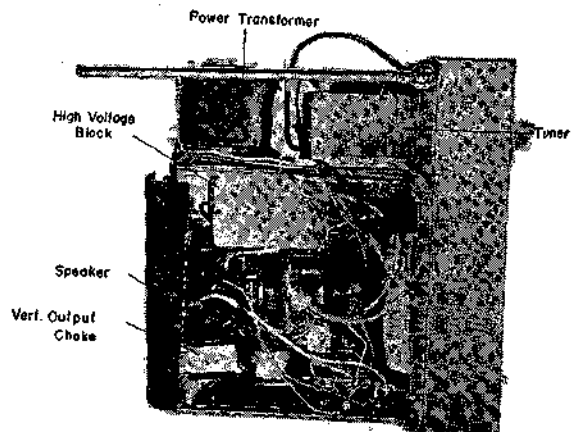

(Fig. 11-2)

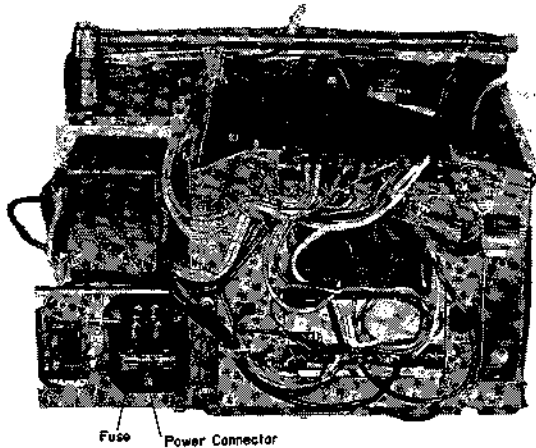

(Fig. 12)

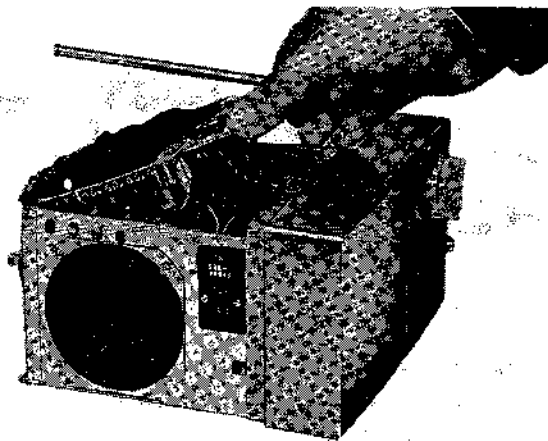

(Fig. 13)

### The Tuner

The Tuner uses three PNP Mesa Type Germanium Transistors (2SA161). One is used in the RF Amplifier, one in the Mixer and one in the Local Oscillator. A Disc Type Turret is used for mounting all the coils and contacts for Channel Selection. Special Contact Points have been designed for easy and positive channel selection. The Transistors and other circuit parts are mounted directly above the Channel Switch and are enclosed within the Tuner Shield. The RF coils for each channel are connected in series but the Oscillator Coil for each channel can be adjusted independently. The AGC characteristics of the set is excellent and though the Input Attenuator has been dispensed with, the set with the Telescopic Antenna extended to its full length can be operated at a field strength of as much as 100 mv/m without overloading the circuits. This maximum field strength allowable can be extended further to 1v/m by retracting the Telescopic Antenna. The AGC Diode (DI) acts as a load for the Tuner and limits the output of the tuner to prevent overloading of the following circuits when the signal input level to the tuner is high.

### Block Diagram of Tuner

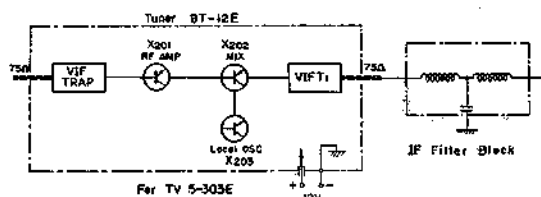

For 5-303E (Fig. 14-1)

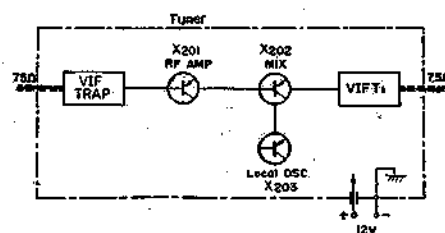

For 5-303T (Fig. 14-2)

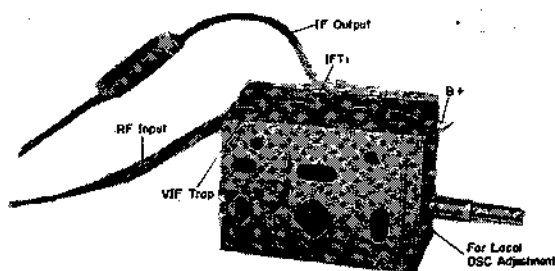

For 5-303E (Fig. 15-1)

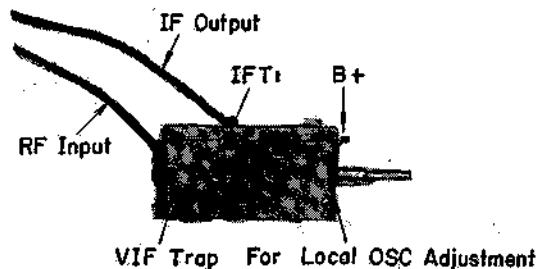

For 5-303T (Fig. 15-2)

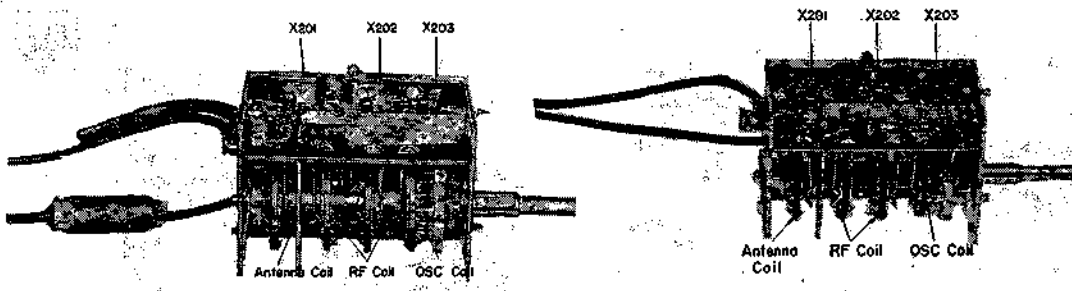

For 5-303E (Fig. 16-1)

For 5-303T (Fig. 16-2)

1. The RF Amplifier

The Antenna Impedance is low ( $75\Omega$ ) and the Input Impedance to the RF Transistor is also low. Between the Antenna and the Transistor Input is a tuned circuit of which the resonant impedance is from  $1K$  to  $4K\Omega$ . Taps are used on both sides of the Tuned Circuit for correct impedance matching which is very important. A tap on the Inductance is made on the Antenna side and a tap is made on the Capacitance on the Transistor side for the impedance matching. The RF Transistor output circuit is double tuned with mutual coupling (Double Peaks). This in combination with the single peak of the input circuit gives an essentially flat Bandwidth of  $6Mc$  for this stage. A Base-grounded Circuit is used for the following reasons.

- 1) The difference in gain between the lower frequencies and the higher frequencies is less in the Base-ground Circuit.
- 2) The adjustment of neutralizing capacitance is very critical in the emitter-grounded circuit so that stability is reduced.
- 3) The Base-grounded Circuit with transistor corresponds to the grounded-grid circuit with vacuum tube. The undesirable feed back between the collector and emitter is greatly reduced in this circuit because the base is grounded. This keeps the amplifier stable even at higher frequencies.

A neutralizing capacitor is used in the emitter circuit as shown in Fig. 17 to prevent oscillation due to stray capacitance.  $R_{ch}$  in Fig. 17-1 is used for a choke coil which grounds the neutralizing point for DC while keeping it at an appropriate AC potential.

Basic Circuit for RF Stage

Neutralizing Circuit for RF Stage

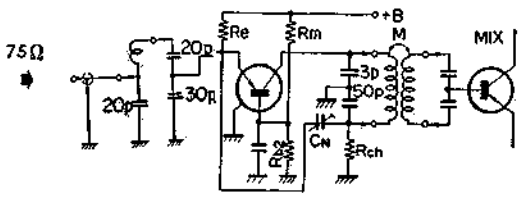

For 5-303E (Fig. 17-1)

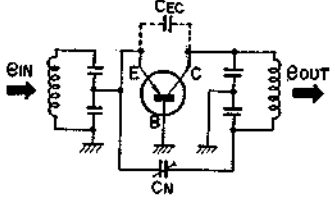

(Fig. 17-3)

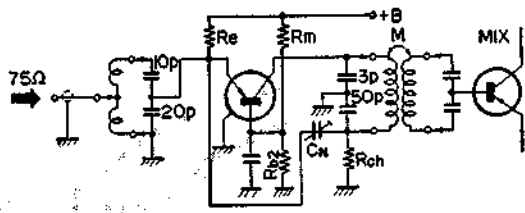

For 5-303T (Fig. 17-2)

A gain of  $14\text{ dB}$  is possible at  $200Mc$  with a circuit of this type but too much gain tends to make the set unstable and hence the gain has been kept to be about  $10\text{ dB}$  in our circuit. The gain on the lower channels tends to be higher than that on the higher channels, and so the damping resistors are inserted in the circuit of the lower channels to make the gain difference between the higher and lower channels within  $\pm 1.5\text{ dB}$ .



## 2. The Mixer Circuit

The Mixer Transistor 2SA161 is emitter-grounded. Impedance matching is made by a capacitance divider in the same way as in the RF Amplifier. The local Oscillator signal is injected into the base of the transistor. The power dissipated in the mixer transistor is very much less (about 1/30~1/50) than the plate loss of the tube mixer. The voltage of the Local Oscillator signal injected is about 0.2 Vrms, which is also much smaller (1/10~1/20) than that in tube mixer. Furthermore, the Gm of the transistor mixer is high and hence the troubles with mixer noise encountered in tube circuits are of no consequence here in our circuit. This circuit is also neutralized to prevent undesired oscillation.

## 3. The Local Oscillator

The Local Oscillator uses a Colpitts circuit. This circuit is well suited for this use as it does not require a tap on the oscillator coil. The transistor (2SA161) is base-grounded. The thermistor in the base circuit serves to prevent oscillator drift due to temperature changes. The drift is kept within 200 Kc. As mentioned before, each oscillator coil is independent of the others so that the oscillation frequency can be adjusted from outside the tuner by adjusting the screw type cores. The cylindrical Fine Tuning Capacitors are separately shielded to prevent radiation from the set. The adjustable range of the Local Oscillation is approx. 1.5 Mc for Channel 2 (channel A for 5-303T) and approx. 3 Mc for channel 11 (channel H for 5-303T).

## Signal Circuit Board Section

The Signal Circuit Board includes the Video IF, AGC, Sound Amplifier, Video Drive and Synchronizing Pulse Separation circuits. (Fig. 18)

### 1. Video IF Section

- ☆ The Video IF Section consists of four stages with five stagger tuned elements.
- ☆ The Video IF is 26.75 Mc while the Sound IF is 21.25 Mc.
- ☆ The bandwidth of this section is 3.75 Mc. (Fig. 19-1)

### 2. Automatic Gain Control (Fig. 19-2)

The Pulse AGC developed by SONY and the Diode AGC are used together in this set.

The operation of the Pulse AGC Circuit is as follows :

The AGC signal is supplied to the Base of X5 from the Video Detector. The pulse which is generated at the Fly Back Transformer is rectified by D6 and applied to the Collector of X5 so that X5 operates only during the synchronizing period. The AGC signal is amplified by X5 and rectified by D3 and is then applied to the Base of X6 through a Filter Circuit. The Time Constant of this circuit is made very small so that the AGC response is extremely fast, thus permitting operation in moving cars where the signal level may vary with extreme rapidity. Then the AGC current from X6 controls the base bias voltage for X1 and X2, and thus the gain of the Video IF stages. The main features of the Pulse AGC are :

#### 1) Quick response

The AGC action is much faster than in conventional circuits because the Time Constant of the filter circuit is very small (approx. 1/1000 second) compared to that in the conventional one (1/10~1/20 sec). Accordingly, stable reception is achieved even when the input signal level varies at a rate of 1/100 second.

#### 2) Noise free AGC action

The AGC action is hardly influenced by noise since the synchronizing pulses only of the signal are utilized. On the contrary, in the ordinary peak value AGC system, the AGC voltage varies considerably with the noise content of the video signal.

#### 3) Effective AGC action

The AGC action is quite effective due to higher gain in the AGC loop. Stability against the variation of the temperature and of the power supply voltage is secured also. The AGC Diode D1 (1T22G) connected in parallel with VIFT2 conducts to lower the Q of the IFT2 when the input level exceeds 10 mV.

### Block Diagram of Signal Circuit Board

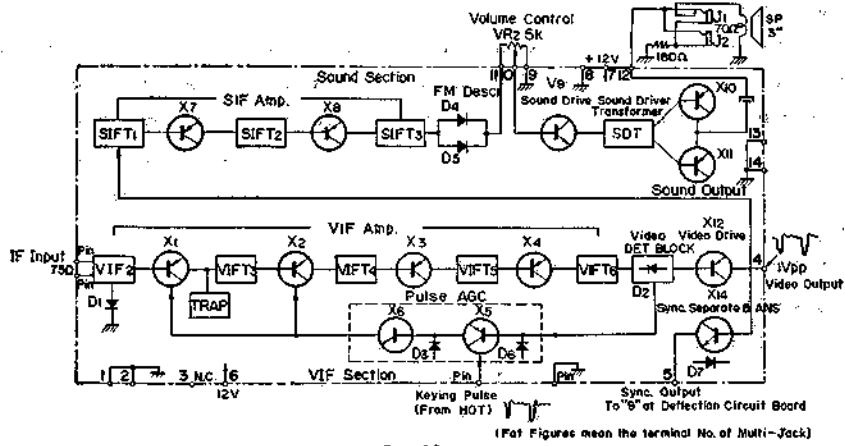

(Fig. 18)

### VIF Freq. Response

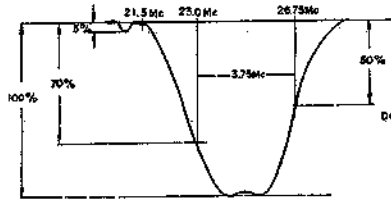

(Fig. 19-1)

### AGC Characteristics

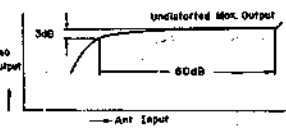

(Fig. 19-2)

### 3. Sound Amplifier Section

The Sound Amplifier Section has two IF stages, a Foster-Seeley Discriminator and two Audio Amplifier Stages. The Output Stage uses the SEPP-OTL (Single Ended Push-pull, No Output Transformer) system. The speaker diameter is 7.5 cm (3") and its impedance is 70Ω. There is a shield plate on SIFT3 to prevent the pulse from the Picture Tube Deflection Yoke to interfere with the sound. The maximum output is 1.50 mW.

### 4. Video Driver

The Video Driver Circuit is of the Emitter Follower Type (Collector-grounded). The Output Impedance is very

### Signal Circuit Board (Mounted Side)

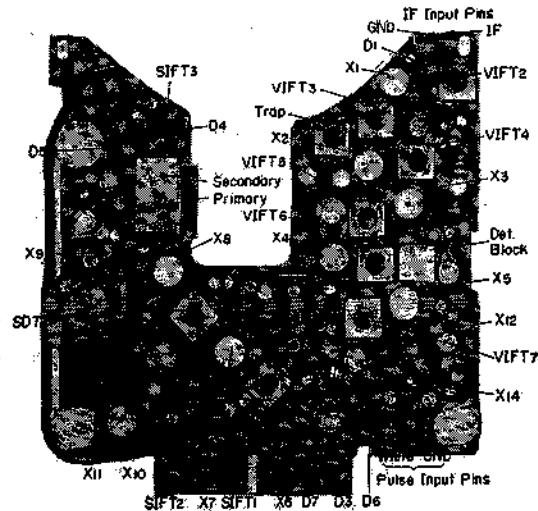

(Fig. 20)

low and this circuit has good frequency characteristics. The Video Signal, Synchronizing Pulse and the Sound are separated at the Emitter of X12 (2SA60).

### 5. Synchronizing Pulse Separation

The synchronizing pulse is separated at X14 which has the Base-grounded and a Bias Current of approximately Zero. The Vertical Synchronizing Pulse is taken from the collector. This stage includes the ANS (Automatic Noise Suppressor) for the synchronizing pulse in which the Diode D7 serves to shortcircuit the pulsing noises of excessive amplitude. This permits stable operation of the set in a car without fear of interference from the ignition sparks and other pulsive noises.

## Deflection Circuit Board and High-Voltage Block Sections

The Deflection Circuit Board contains the Video Output and the Vertical and Horizontal Deflection Circuits.

### 1. Video Output Circuit (See Fig. 21)

A Mesa Type Silicon Transistor (2SC15, X13) is used in the Video Output Circuit. Over 40 Vpp of output is obtained from this circuit. The Picture Tube requires 30 Vpp for sufficient contrast. The Contrast Control is obtained by varying the feedback current by means of the Variable Resistor VR3 which is located in the Emitter Circuit of X13. The gain of the stage can be varied by 16 dB with this control. The Frequency Response is almost flat to 3 Mc by the use of Shunt-peaking (L501-R508) and Series-peaking (L502-R509). Since the Video IF Bandwidth is 3.75 Mc and the beam spot of the Picture Tube is very small, a very sharp picture is obtained. The Horizontal resolution is more than 300 lines and the Vertical, 400 lines. X13 is cut-off during the Blanking Period by the application of pulses from the Horizontal and Vertical Deflection Circuits. The Blanking Pulses are applied to the Emitter of X13.

### Deflection Block

(Fat figures mean the terminal No. of Multi-Jack)

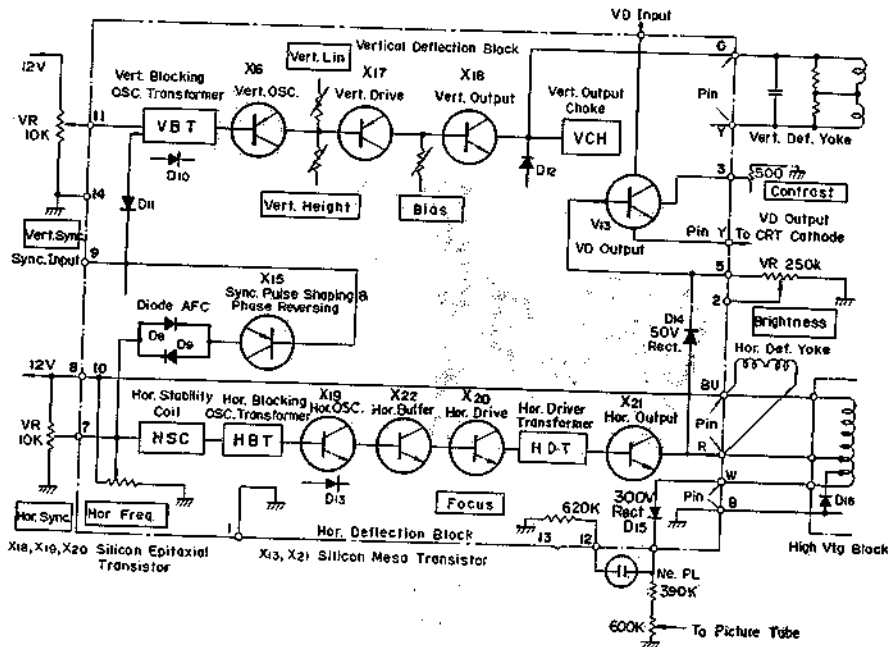

(Fig. 21)

### Deflection Circuit Board (Mounted Side)

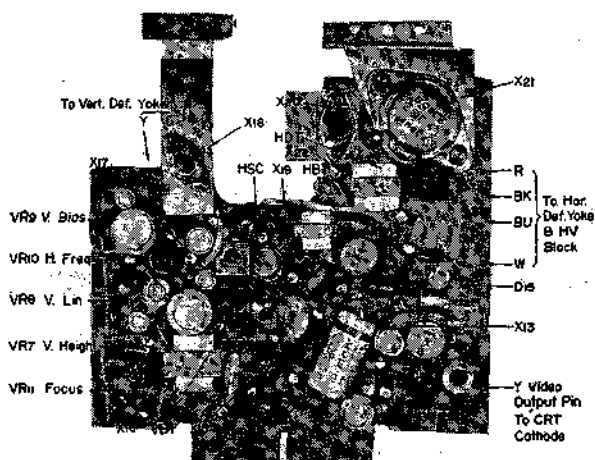

(Fig. 22)

### High Voltage Block

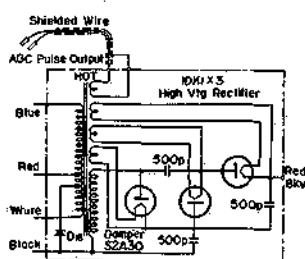

(Fig. 23)

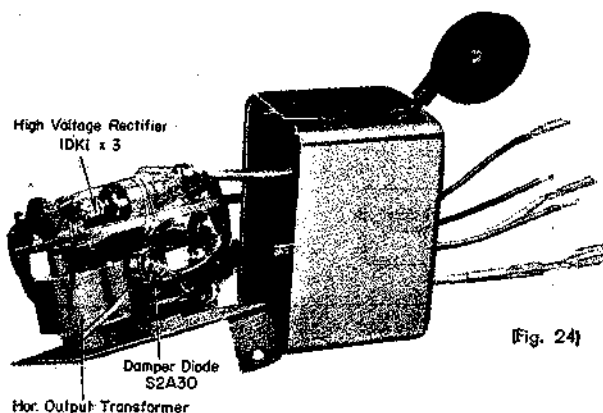

(Fig. 24)

#### 2. Vertical Deflection Section (See Fig. 21)

The Vertical Deflection Sawtooth Wave is generated by blocking oscillations in the circuit of X16. It is then amplified by X17 and X18 and applied to the Vertical Deflection Yoke of the Picture Tube. Vertical Amplitude and Linearity are adjusted by Variable Resistors VR7 and VR8 in the Base Circuit of X17. An Epitaxial Transistor X18 (2SC140) is used in the Vertical Deflection Output Circuit. The Epitaxial Transistor is used in this circuit because of the characteristics of being able to withstand the high pulse voltages present in this circuit and because of freedom from temperature effects. The amplitude of the vertical pulses will not decrease with

a rise in temperature. The Vertical Deflection Coil on the Picture Tube is of the Toroidal Type which is more efficient than the conventional type.

**3. Horizontal Deflection Section (See Fig. 21)**

The Horizontal Deflection Pulse is generated by blocking oscillations in the circuit of X19 and is amplified by X22 and X20 which drives X21. X21 in turn generates the Sawtooth Wave which drives the Horizontal Deflector Coil. The Horizontal Output Transistor (X21) is also connected to the Hor. Output Transformer and supplies the input for the High Voltage Circuit with the Flyback Pulse during Cut-Off. All of the Transistors in the Horizontal Deflection Circuit are of the Silicon Type. This assures stable operation almost free from temperature effects.

**4. High Voltage Block**

The High Voltage Block consists of the Horizontal Output Transformer, Damper and the High Voltage Rectifier. All are housed together in one metal case. The Flyback Pulse is stepped up, rectified and the resulting voltages of 8 KV, 300 V and 50 V are applied to the Anode of the Picture Tube, the Second Grid of the Picture Tube and the Video Transistor (X13) respectively. The 8 KV is obtained by means of the three rectifier tubes in voltage tripler circuit.

**5. Focus Adjustment**

The voltage for the Second Grid of the Picture Tube goes also to the Potentiometer VR11 through the Neon pilot Lamp (Ne-PL). The Focusing Voltage is obtained from this Potentiometer and is variable between 0 and 180 V DC.

## Power Supply Section

117 V AC input is converted to 12 V DC by four (4) Selenium Rectifiers in a Bridge Connection as shown in Fig. 26. The Power Transformer is located very near the Picture Tube. Power Transformer with oriented-core is used in this set to prevent any trouble from Flux Leakage.

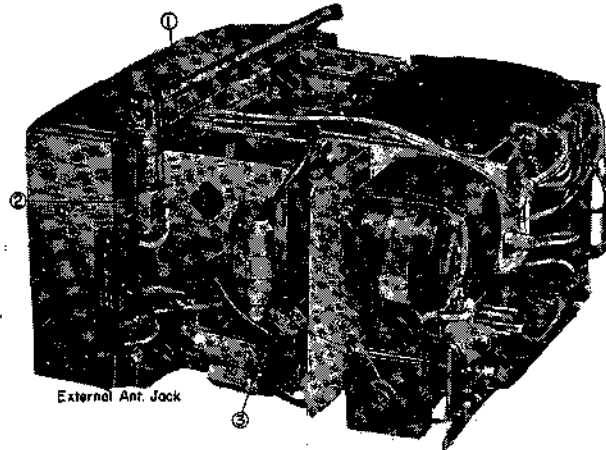

(Fig. 25)

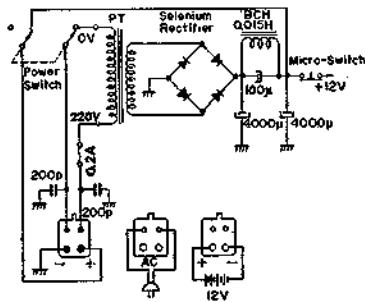

(Fig. 26)

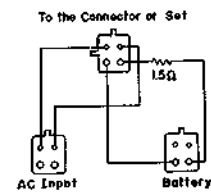

(Fig. 27)

## Method of Disassembling the Set

### To Remove the Front Control Panel :

1. Pull all Control Knobs straight out. The Fine Tuning Knob may be somewhat difficult to remove—use force.
2. Remove the two small screws on the Front Control Panel. The Front Control Panel can now be removed. (Fig. 28)

### To Remove the Back Cabinet Cover :

Remove screw ① (located on the top) and ② (located on the left side). Remove screws ③, ④, ⑤ and ⑥ on the back. The Back Cover can now be removed by pulling straight back. (Fig. 29)

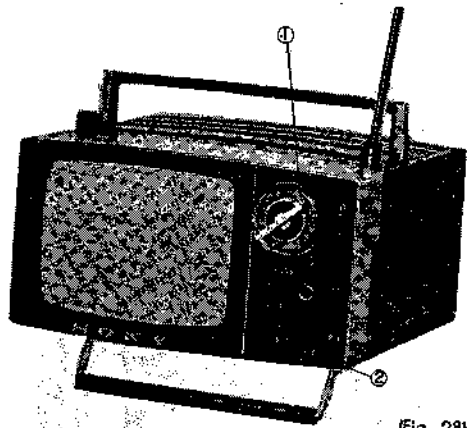

(Fig. 28)

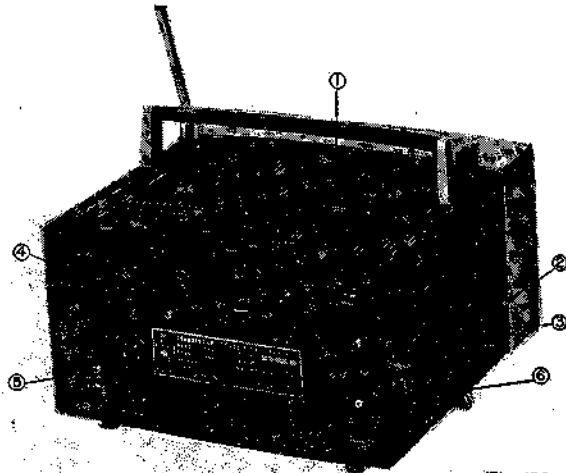

(Fig. 29)

### To Remove the Telescopic Antenna and the Tuner :

1. Pull off the Pin Connectors of the Tuner IF Lead Wire and the shielded Ground Wire from the Terminals on the Signal Circuit Board as shown in Fig. 30.
2. Remove screws ①, ② and ③. ③ holds the back of the Tuner. (Fig. 30)
3. Push the Telescopic Antenna and the External Antenna Connectors in the direction shown by the Arrows in Fig. 30. The Telescopic Antenna and the Connectors can now be detached.

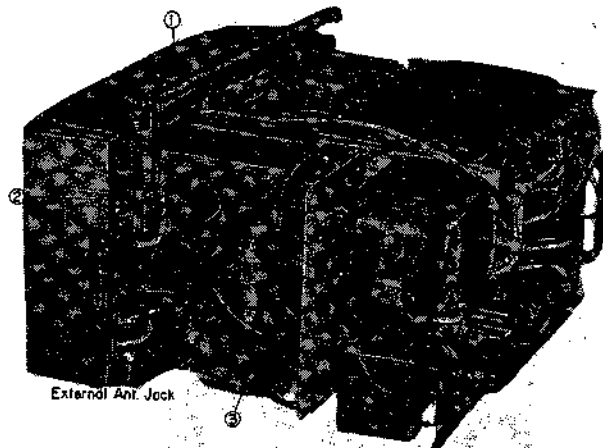

(Fig. 30)

4. The Tuner can be detached by removing two screws on the Front located near the Tuning Control Shaft. One screw is on the Front Panel and the other is inside on the Tuner as shown in Fig. 31.

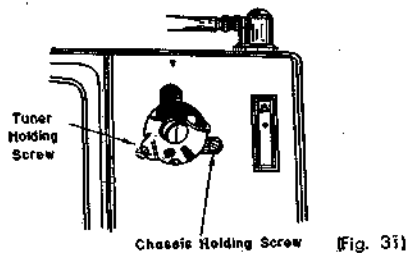

5. The Tuner, Telescopic Antenna and Antenna Connectors can be removed from the set by unsoldering the Red Wire to the Front of the Tuner, the Black Wire to the Chassis and the Yellow Wire with the Resistor to the Antenna Jack. The IF Lead Wire to the Tuner with the Pin Connectors can be pulled through from the back of the Picture Tube. (Fig. 32~33)

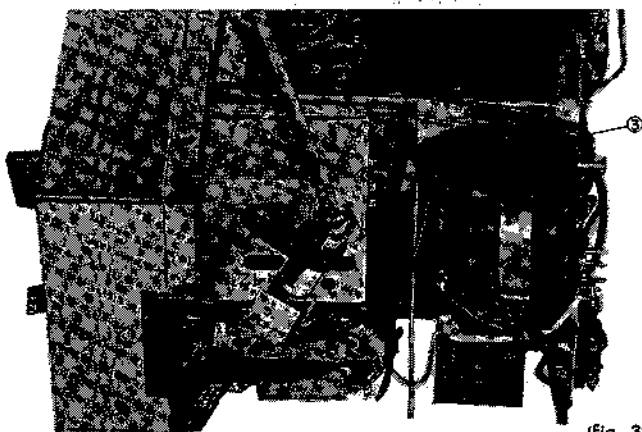

(Fig. 32)

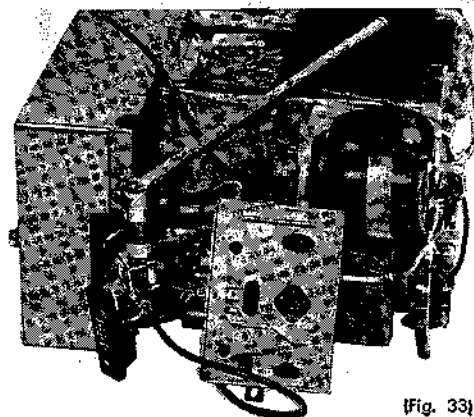

(Fig. 33)

**To Remove the Signal Circuit Board:**

Remove Screws ① and ②. Slightly loosen the Screw ⑧ holding the Connector Socket on the back of the Chassis (Fig. 34). Pull out the two Connectors from the Pins on the back side of the Signal Circuit Board. The Block can be removed as a unit by pulling directly away from the Connector Socket.

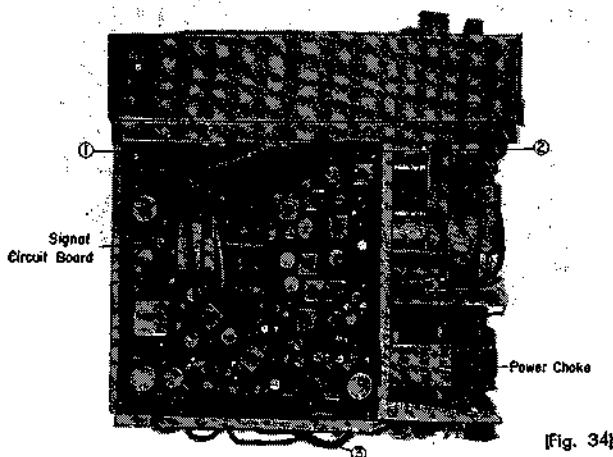

(Fig. 34)



**To Remove the Deflection Circuit Board:**

1. Remove Screws ①, ② and ③. (Fig. 35)



[Fig. 35]

2. Pull out the connectors shown in Fig. 36 & Fig. 37.

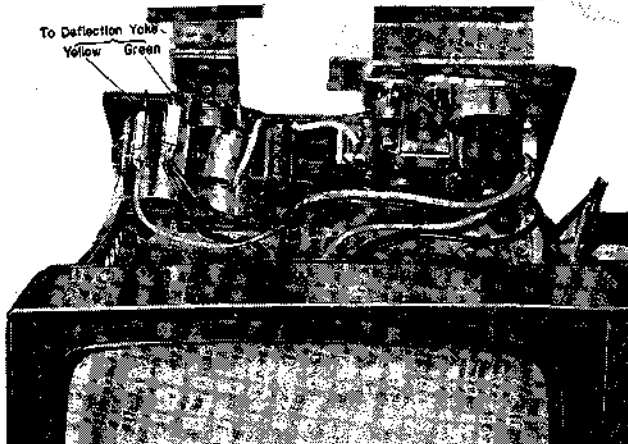

[Fig. 36]

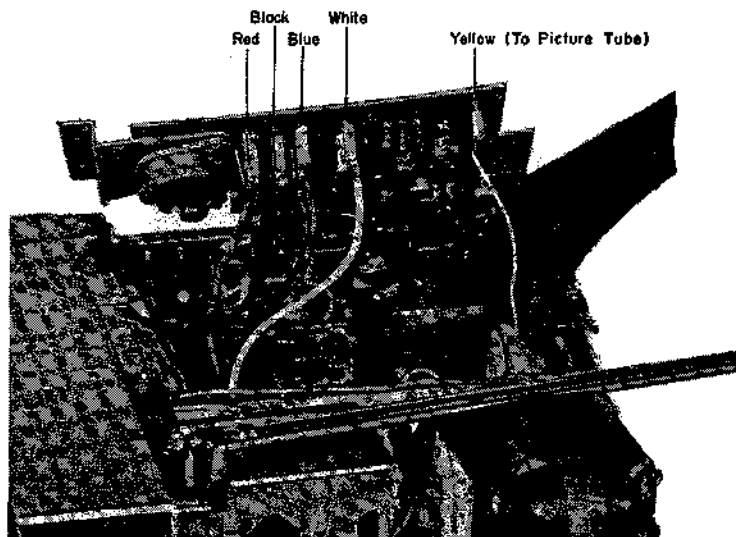

[Fig. 37]

Note: SONY Extension Cable and Circuit Connector are available to make service on the Circuit Boards more convenient. (Fig. 38 & Fig. 39)

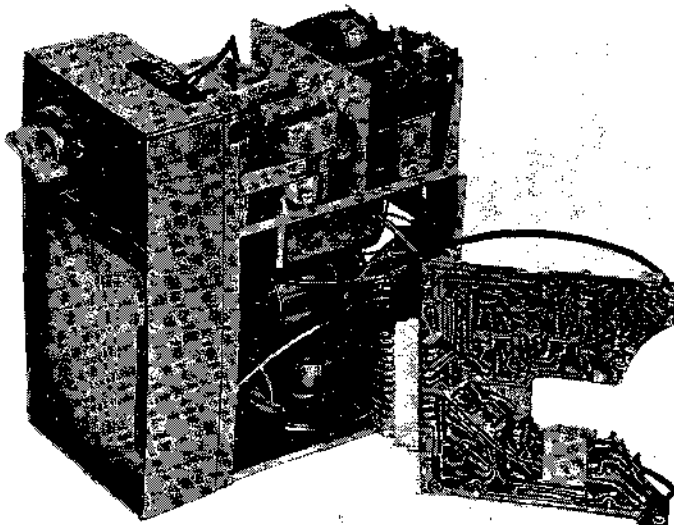

(Fig. 38)

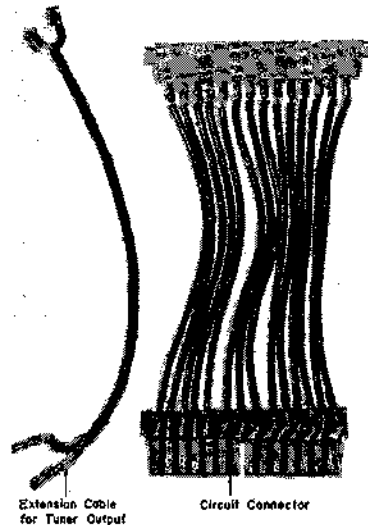

(Fig. 39)

**To Remove the Chassis from the Front Panel: (Fig. 40)**

Remove Screws ②, ③ and ④. Remove the Screw ① from the front side after pulling off the Channel Selector Knob and the Fine Tuning Knob (Refer to Fig. 4 on page 3)

Unsolder the Red, Blue and Black Wires from the Pin Connectors. These wires go to the Picture Tube Yoke. Also unsolder the Green Wire from the Choke Coil located just below the Speaker. Pull off the High Voltage Anode Connector from the side of the Picture Tube. This is a Snap Fastener but use caution in removing it. Pull off the Socket of the Picture Tube straight back.

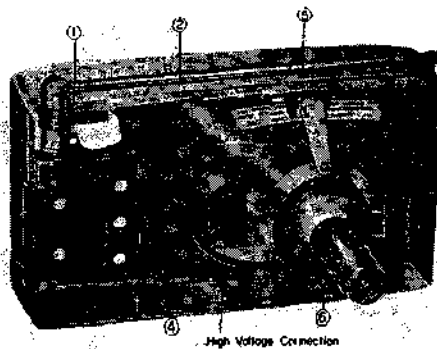

(Fig. 40)

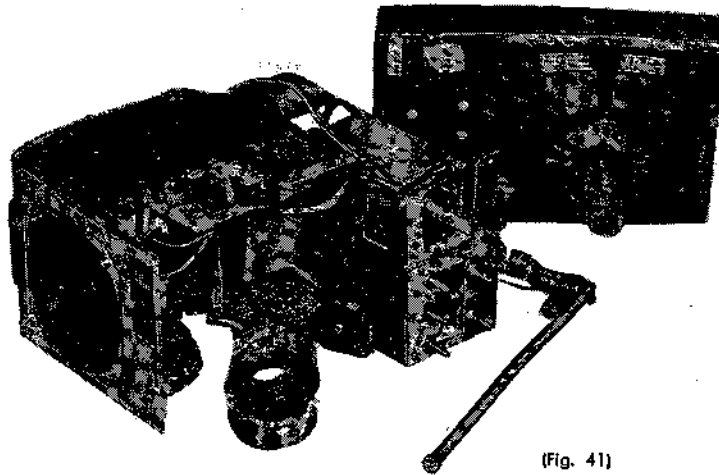

(Fig. 41)

**To Remove the Picture Tube :**

Remove the Screws and Nuts ⑤ and ⑥ shown in Fig. 40 and lift up the Picture Tube.

**To Remove the High Voltage Block :**

1. Unsolder three lead wires (Red, Blue & Black).
2. Pull off the Anode Cap
3. Pull off the Pulse Supplying Pin Connectors coming from the Signal Circuit Board.
4. Remove the Phillips Screw

NOTE: It is not recommended that the High Voltage Block be disassembled because a special Insulating Material is used inside to coat all High Voltage Points.

## Trouble Shooting

### by Replacement of the Defective Block

Provisions have been made in this Micro TV for easy servicing. The main part of the set is made of the four blocks of the Tuner, the Signal Circuit Board, the Deflection Circuit Board, and the High Voltage Block. Each of these blocks has complete interchangeability and hence the servicing can be performed by simply replacing the defective Block with a new one.

The ways of judging which Block is defective and the method of replacing the Blocks will be given below. In servicing according to this method, the following tools and parts are needed.

**Replacement Blocks :** (See Fig. 42)

Tuner, Signal Circuit Board, Deflection Circuit Board, and High Voltage Block

**Tools and Meters :**

Circuit-tester, of internal resistance around  $20\text{ K}\Omega/\text{V}$  Cord with Clips.....2 pieces

Electrolytic Condenser,  $3\mu\text{F}$ , 50 V or more.....1 piece

Resistor, around  $15\text{ K}\Omega$ .....1 piece

Screw Drivers

For 3 mm Screws, Phillips and ordinary

For 2.6 mm Screws, Phillips and ordinary

No. 3 for watches (for adjustment of local oscillator)

Tweezers

Soldering Iron

### Raster

#### 1. No Raster and No Sound

Suspectable Item : ☆ Power Supply

Check the power supply. If there is no trouble in the power supply, there must be two or more Blocks defective. Then, proceed with the checking according to the following.

#### 2. No Raster

See first whether the Neon Lamp is lit.

##### 1) The Neon Lamp is OFF.

Suspectable Items : ☆ Deflection Circuit Board

☆ High Voltage Block

a) Replace the Deflection Circuit Board.

b) If the Neon Lamp is not lit after (a), replace the High Voltage Block.

##### 2) The Neon Lamp is lit.

Suspectable Items : ☆ High Voltage Block

☆ The Picture Tube

☆ The Brightness Control Circuit

a) See whether the filament of the Picture Tube is ON. If the filament is OFF, check the socket of the Picture Tube. The pins for the filament are Nos. 3 and 4.

b) If the filament is ON, the trouble is probably with the High Voltage Block. Before proceeding on to replace the High Voltage Block, see whether the cathode circuit of the Picture Tube (the Brightness Control Circuit) is all right.

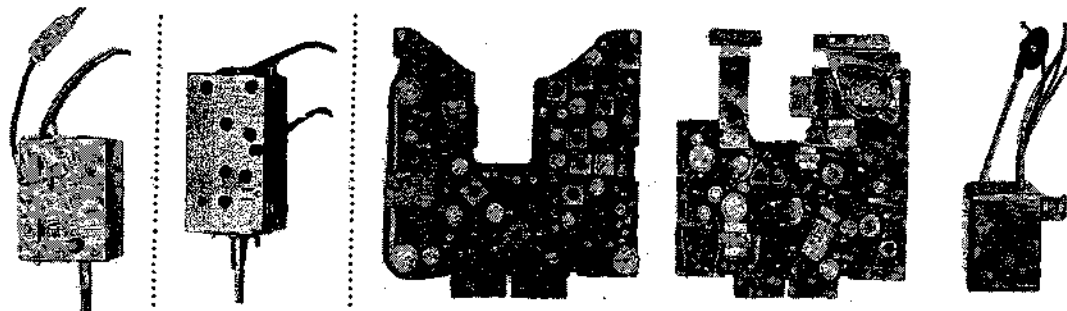

Tuner For 5-303E      Tuner For 5-303T      Signal Circuit Board      Deflection Circuit Board      High Voltage

(Fig. 42)

Circuit Diagram for Video Amp. (Fat Figures mean the terminal No. of Multi-Jack)

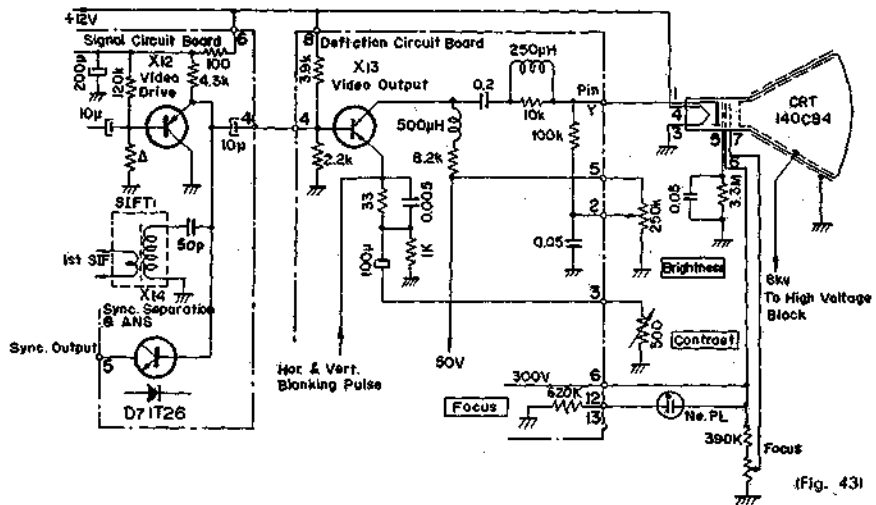

(Fig. 43)

To do this, measure the cathode voltage from the copper-clad side of the Deflection Circuit Board. (Refer to Fig. 43) If this voltage is varied between 0 and 40 to 50 volts by an adjustment of the Brightness Control, the cathode circuit is all right, and the High Voltage Block is to be replaced.

If this voltage is abnormal, the Brightness Control Circuit on the Deflection Circuit Board must be checked.

- c) If the raster still does not appear after replacing the High Voltage Block, the Picture Tube may be defective.

**CAUTION**

**NEVER ATTEMPT TO CHECK THE HIGH VOLTAGE (8 KV) CIRCUIT BY SPARK TEST**

The high voltage is often tested by a Spark Test. But, in Transistor TV this is likely to cause damage not only to the Horizontal Deflection Circuits but also to other seemingly not related parts of the set. Especially, the High Voltage spark will adversely affect the transistors on the Signal Circuit Board because of the Pulse AGC circuit employed.

- 3. Raster appears but is abnormal.
  - First of all, check the 12 V DC Power Supply.
  - 1) Too small Raster
  - Suspectable Item: ☆ Deflection Circuit Board

#### Replace the Deflection Circuit Board

#### 2) Raster is dark.

Suspectable Items : ☆ Picture Tube  
☆ High Voltage Block

a) When the Raster Size is normal but is not bright enough, the trouble is almost certainly with the Picture Tube.

b) When the Raster spreads out and gets dark while the brightness is meant to be increased, the trouble is with the reduced emission of the High Voltage Rectifier Tube and the High Voltage Block must be replaced.

#### 3) The left side of the Raster is elongated and gets dark.

Suspectable Item : ☆ High Voltage Block

This is an indication of broken Damper Diode, and hence the High Voltage Block must be replaced.

### Video Output and Synchronization

#### 1. No Picture (Sound is normal)

Suspectable Items : ☆ Deflection Circuit Board  
☆ Signal Circuit Board

Since the Video Output Circuit of this set is on the Deflection Circuit Board, check the Video Output Circuit as follows :

Apply AC test voltage taken from the secondary winding of the transformer through a 15 K $\Omega$  Resistor and a 3 $\mu$ F, 50 WV or more, Electrolytic Capacitor, to the Terminal No. 4 (The input terminal to the Video Output Circuit) of the Deflection Circuit Board as shown in Fig. 44. If the AC hum appears on the Picture Tube, replace the Signal Circuit Board. If not, replace the Deflection Circuit Board.

#### 2. Failure of Synchronization

##### 1) Failure of both Horizontal and Vertical Synchronization

Suspectable Items : ☆ Deflection Circuit Board  
☆ Signal Circuit Board

Measure the voltage at Terminal No. 5 of the Signal Circuit Board and decide whether the trouble is with the Signal Circuit Board or with the Deflection Circuit Board. The normal value of the voltage is around 10.5 V. (Fig. 44)

If the voltage is more than 10.5 V, replace the Signal Circuit Board.

If it is abnormally low, replace the Deflection Circuit Board.

##### 2) Failure of either Horizontal or Vertical Synchronization alone

Suspectable Item : ☆ Deflection Circuit Board

In this case replace the Deflection Circuit Board.

#### 3. No Picture and No Sound

Suspectable Items : ☆ Tuner  
☆ Signal Circuit Board

a) Replace the Signal Circuit Board and see the result.

b) Apply the output from another tuner to the Input Terminal of the Signal Circuit Board as shown in Fig. 45, and see the result. The power to this Tuner is to be taken from the set with a length of cord with clips.

4. Only one or a few Channels are defective

Suspectable Item : ☆ Tuner

If the Antenna System and the Fine Tunings are all right, the trouble is with the Tuner. This can be checked by use of another Tuner as mentioned in 3 (b).

5. Other Troubles

- Suspectable Items :
- ☆ Tuner
  - ☆ Signal Circuit Board.
  - ☆ Deflection Circuit Board

For troubles like low contrast, poor signal-to-noise ratio and poor resolution, replace the Signal Circuit Board first. Then, if the signal-to-noise ratio is still poor, replace the Tuner. If the contrast is low, replace the Deflection Circuit Board.

To Check Video Amp. & Synchronization Circuit

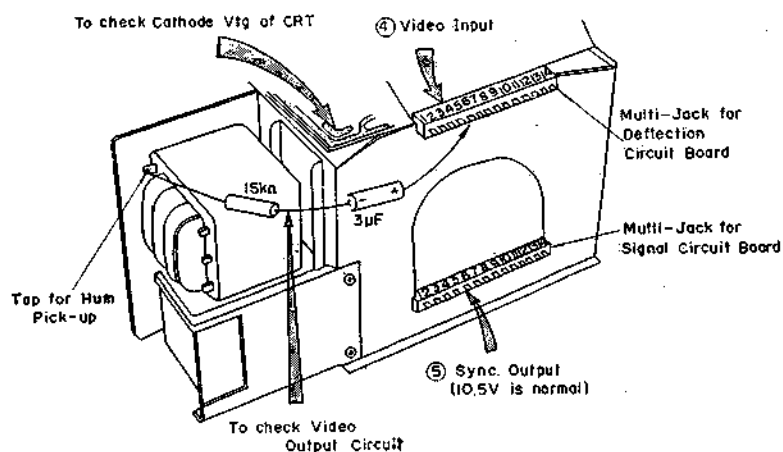

(Fig. 44)

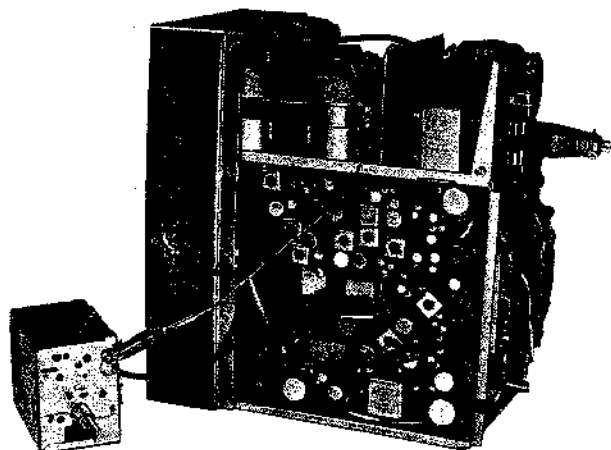

(Fig. 45)

**Sound (Picture is normal)**

1. No Sound

Suspectable Items :           ☆ Speaker  
  ☆ Signal Circuit Board

Listen with the earphone.

- a) Check the Speaker and the Earphone Jack if sound is heard through the earphone
- b) If still no sound can be heard, replace the Signal Circuit Board.

2. Sound is distorted.

Suspectable Items :           ☆ Speaker  
  ☆ Signal Circuit Board

Judge by hearing the sound whether the trouble is with the defective Speaker. If the trouble is not caused by the Speaker, replace the Signal Circuit Board.

3. Buzzing

Suspectable Items :           ☆ Antenna  
  ☆ Fine Tuning  
  ☆ SIFT3  
  ☆ Signal Circuit Board

- a) If the Buzz appears only on some specific channel, the trouble is not with the set itself. Adjust the Antenna and the Fine Tuning.
- b) If the Buzz appears on all channels, adjust the blue core of SIFT3.
- c) Then, if the Buzz still exists, replace the Signal Circuit Board.

4. Other troubles with Sound

Suspectable Item :           ☆ Signal Circuit Board

For other troubles with the sound, replace the Signal Circuit Board.



# SONY®

## SUPPLEMENT TO SERVICING GUIDE

### MICRO TV 5-303E

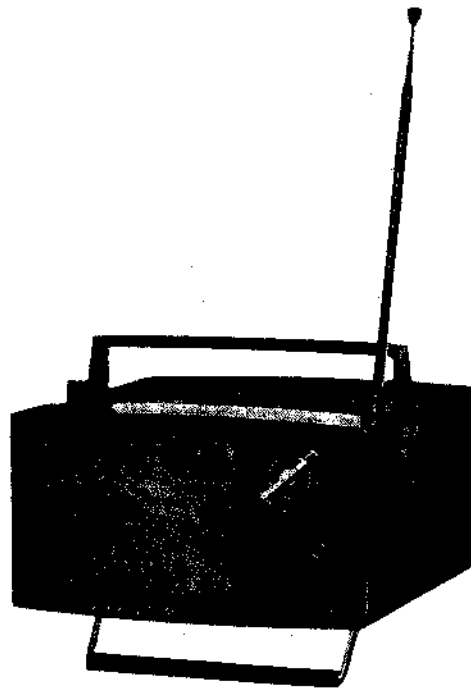

---

#### CONTENTS

	Page
Mounting Diagram	
Signal Block .....	2
Deflection Block .....	3
Schematic Diagram .....	5, 6
Voltage Distribution Chart	
Tuner .....	4
VIF AMP Circuit .....	4
Sound Circuit .....	7
SYNC SPLIT Circuit .....	7
SYNC SEP, AMP & NOISE LIMIT Circuit .....	7
VERT Deflection Circuit .....	8
Video Output Circuit .....	8
HOR DEF Circuit .....	9
Electrical Parts List (A) .....	10, 11, 12
Electrical Parts List (B) .....	12, 13
Mechanical Parts List .....	13, 14

# Mounting Diagram

— Signal Block —

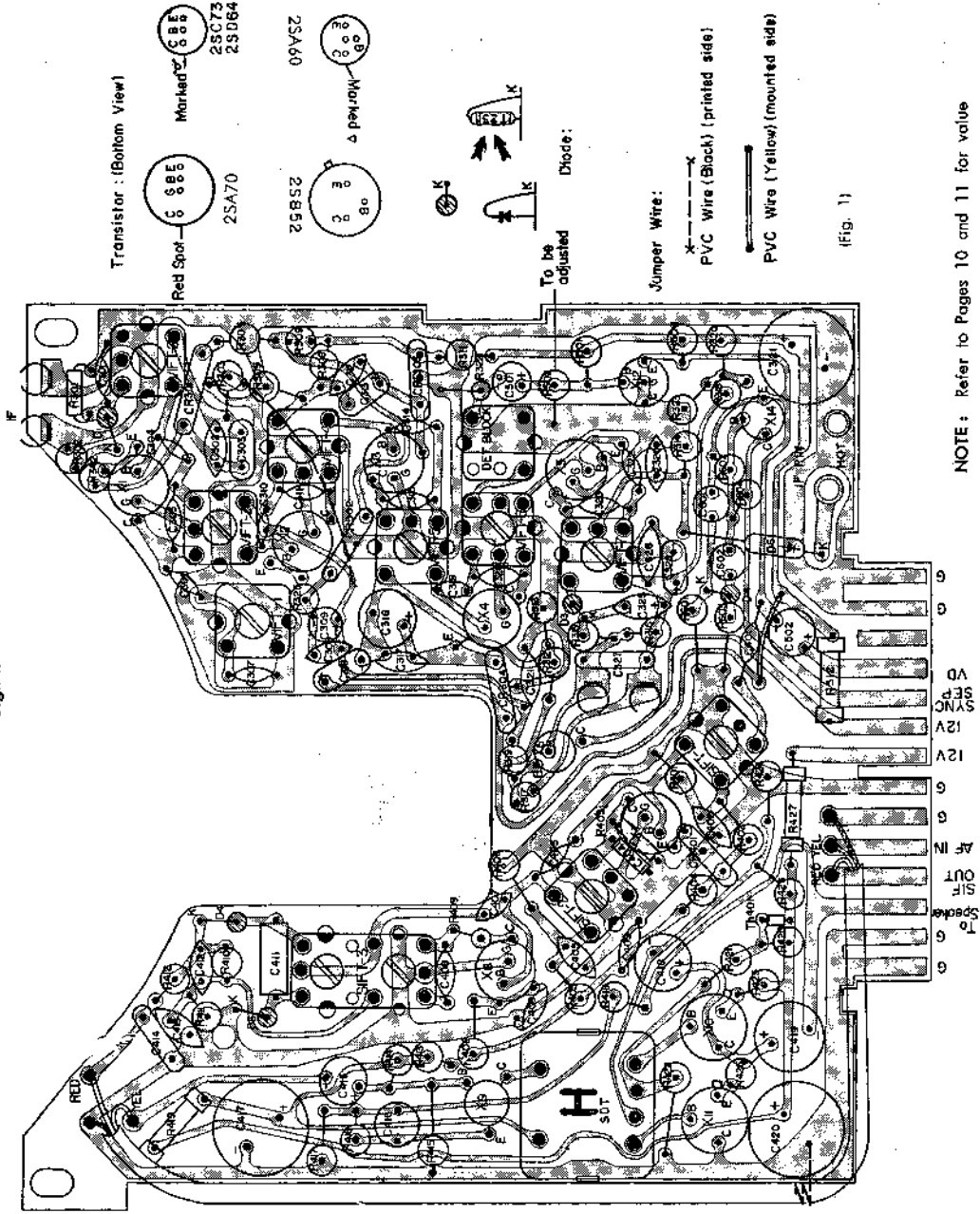

- Transistor: (Bottom View)
- Red Spot: C 88E 88E 88E 25C73 25D64
  - Marked: 2SA70
  - Marked: 2SB52
  - Marked: 2SA60

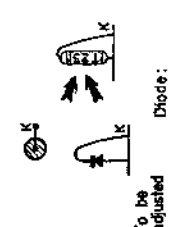

- Diode:
- Jumper Wire:
- X---X PVC Wire (Black) (printed side)
  - PVC Wire (Yellow) (mounted side)

(Fig. 1)

NOTE: Refer to Pages 10 and 11 for value of the circuit constants.

# Mounting Diagram

--- Deflection Block ---

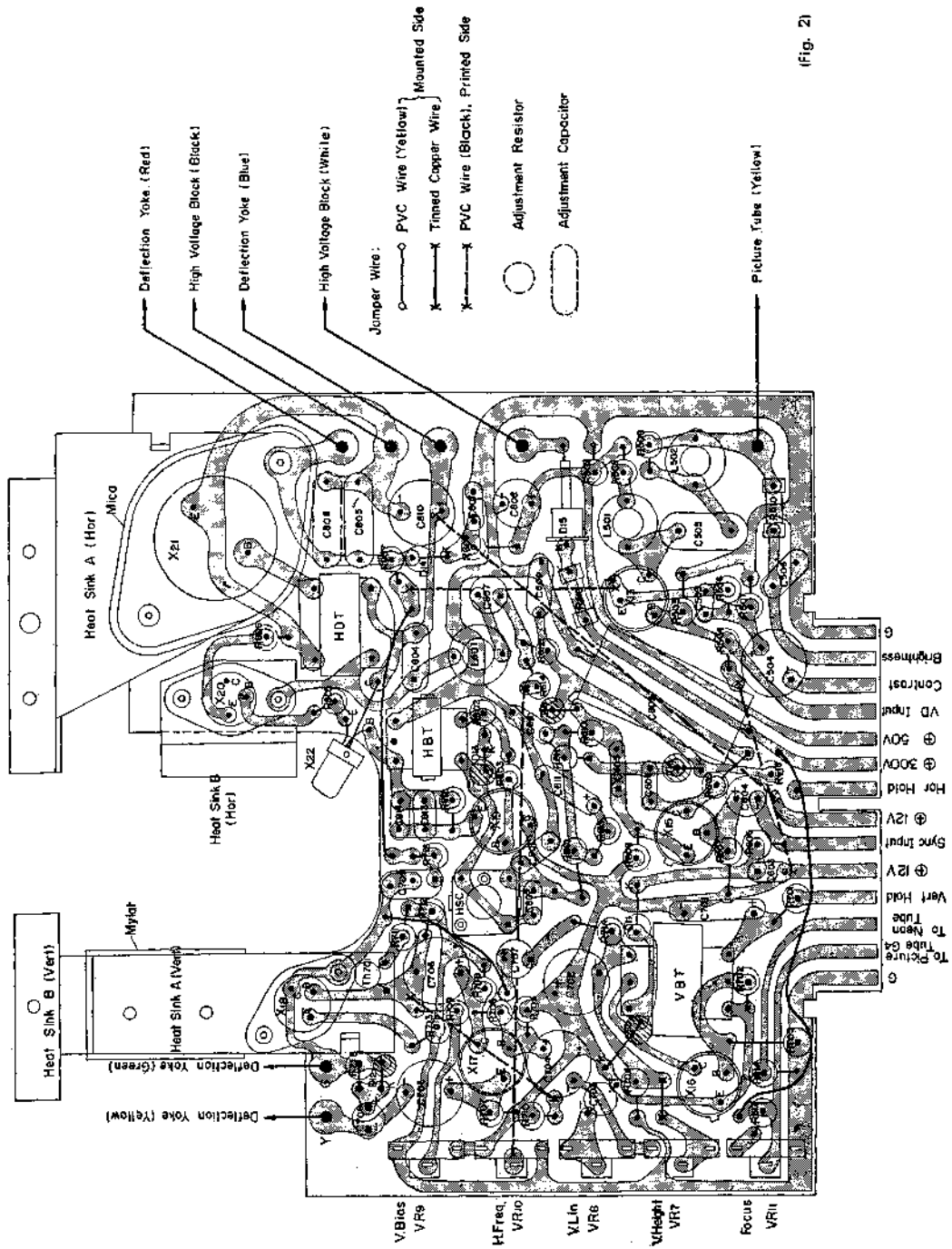

(Fig. 2)

## Voltage Distribution Chart

— Tuner —

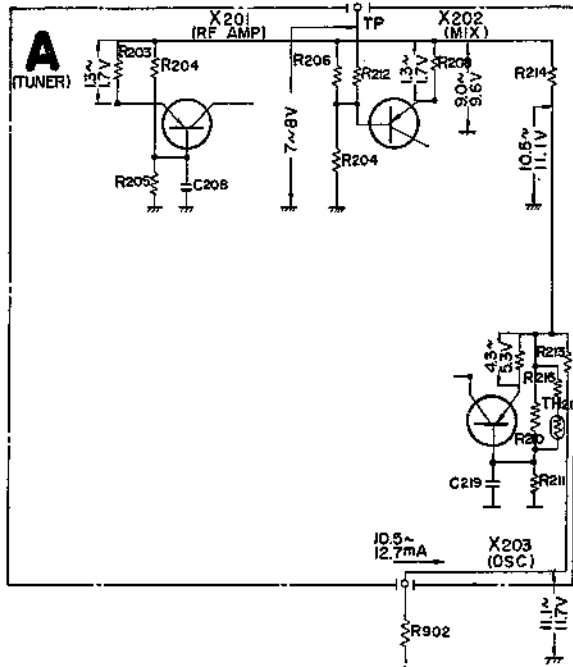
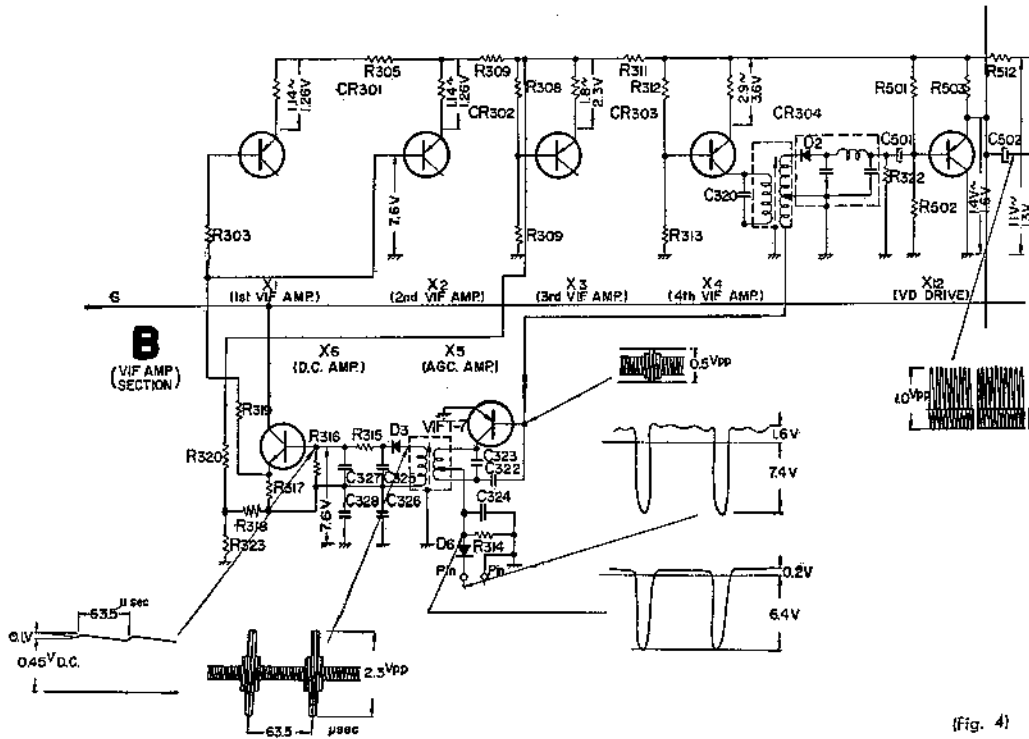

Fig. 3)

## Voltage Distribution Chart

— VIF AMP Circuit —



(Fig. 4)

# Schematic Diagram for TV 5-303E

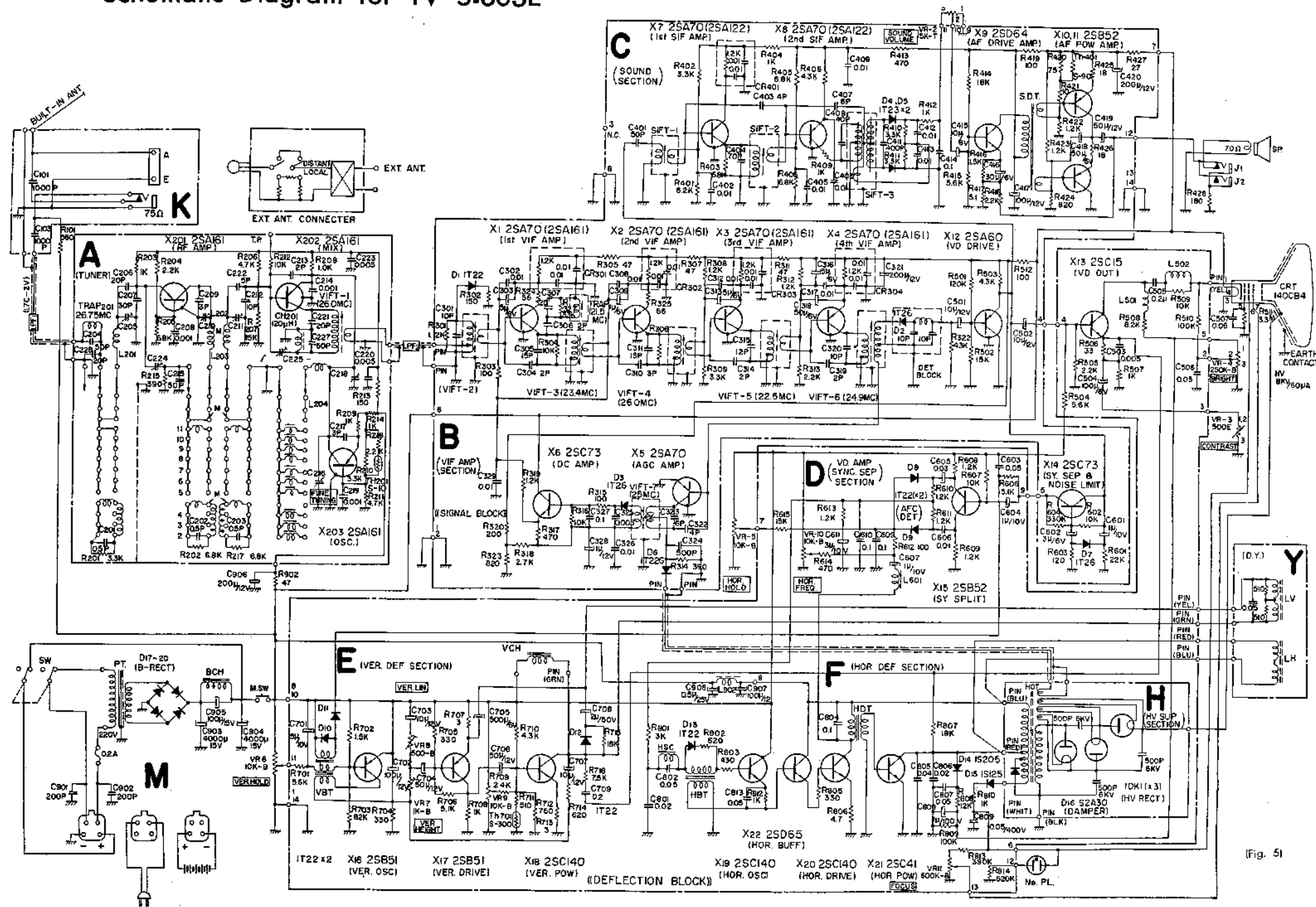

(Fig. 5)

- △ To be adjusted and value may differ from that indicated.
- \* Used in some set for adjustment purpose.

NOTE: Refer to pages 10 and 11 for value of the circuit constants.

**Voltage Distribution Chart**  
--- Sound Circuit ---

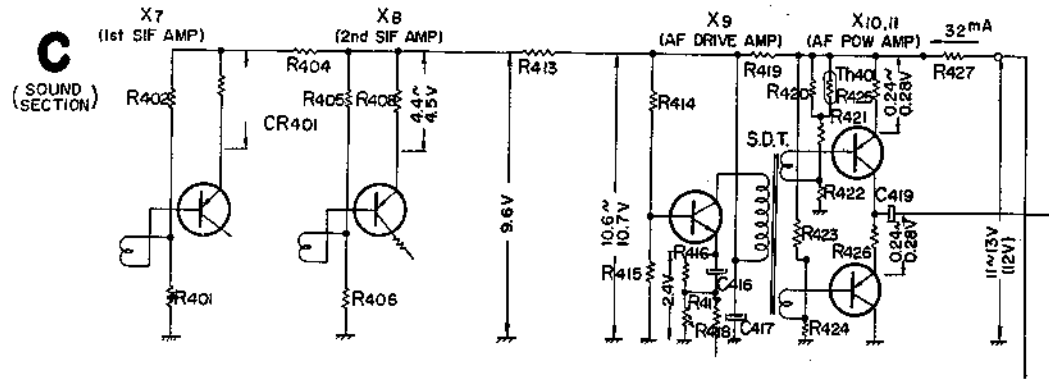

(Fig. 6)

**Voltage Distribution Chart**  
--- SYNC SPLIT Circuit ---

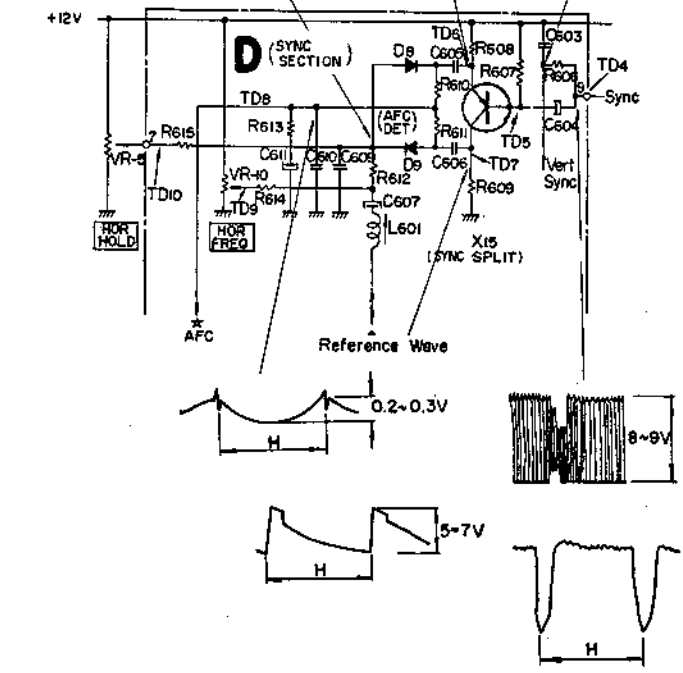
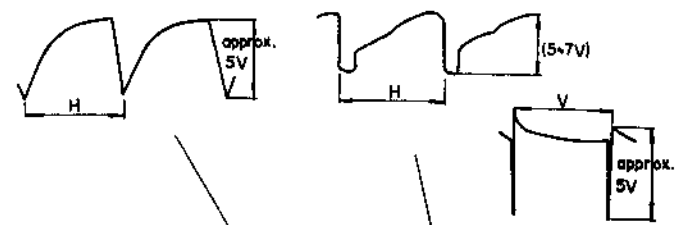

DC Voltage: TD<sub>4</sub>...10V, TD<sub>5</sub>...11.5V, TD<sub>6</sub>...10.5V, TD<sub>7</sub>...1.5V  
TD<sub>8</sub>...5V, TD<sub>9</sub>...6.5V, TD<sub>10</sub>...5.5V

(Fig. 7)

**Voltage Distribution Chart**  
--- SYNC SEP, AMP & NOISE LIMIT Circuit ---

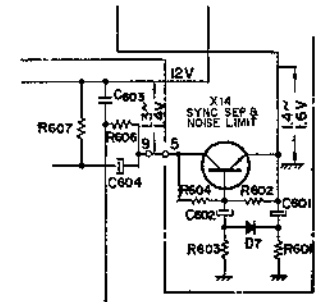

(Fig. 8)

**Voltage Distribution Chart**  
--- VERT DEFLECTION Circuit ---

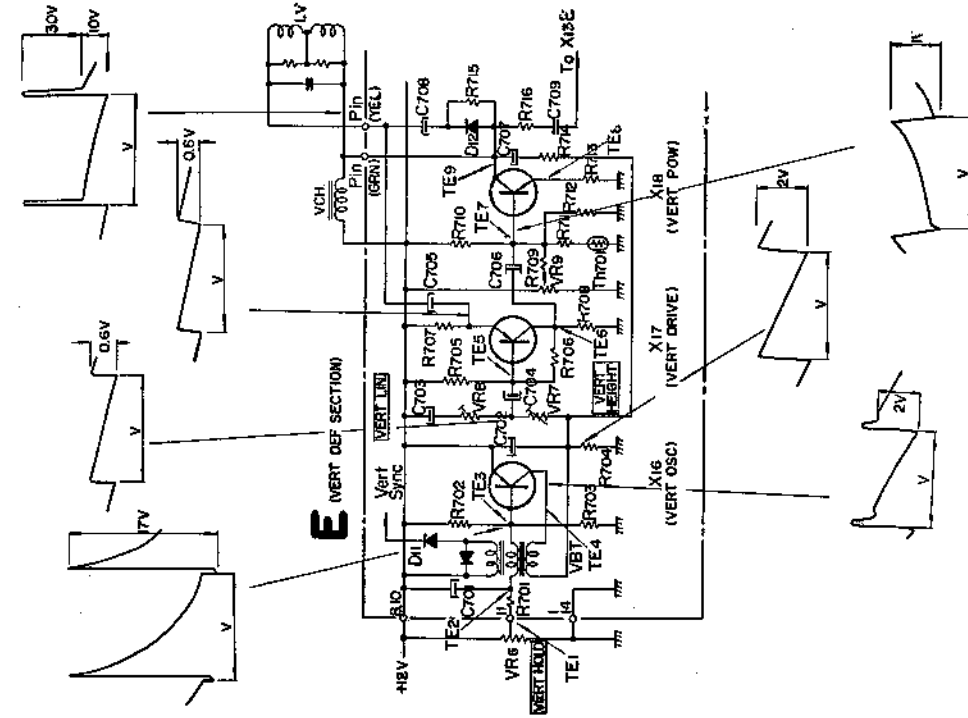

DC Voltage: TE<sub>1</sub>...6-9V, TE<sub>2</sub>...16V, TE<sub>3</sub>...16V, TE<sub>4</sub>...5.5V, TE<sub>5</sub>...11.7V,  
TE<sub>6</sub>...8.0V, TE<sub>7</sub>...1.0V, TE<sub>8</sub>...0.33V, TE<sub>9</sub>...9.5V

(Fig. 9)

**Voltage Distribution Chart**  
--- Video Output Circuit ---

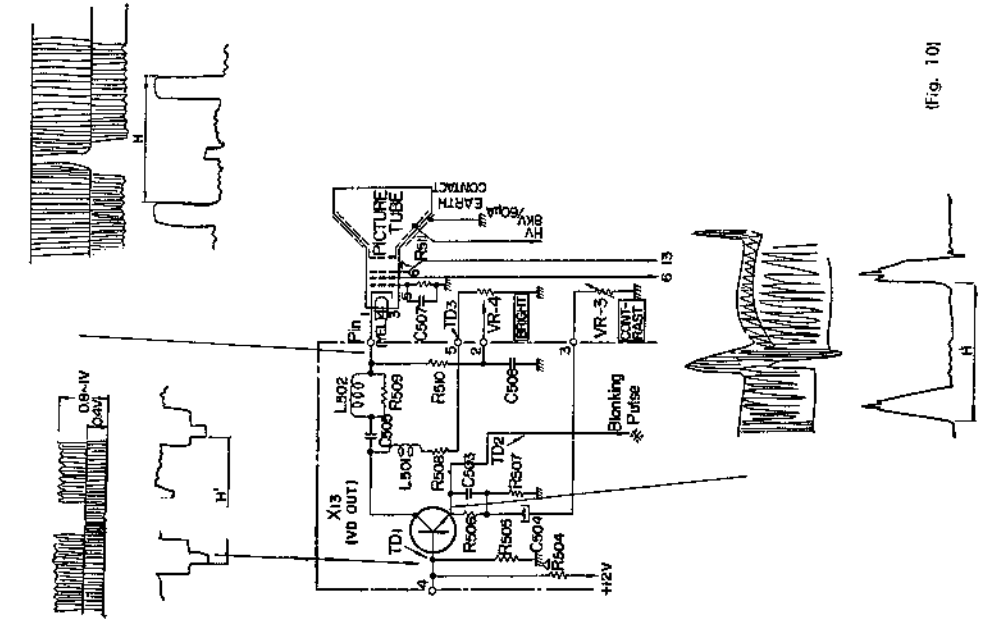

DC Voltage: TD<sub>1</sub>...3.2V, TD<sub>2</sub>...2.6V, TD<sub>3</sub>...50V

(Fig. 10)

**Voltage Distribution Chart**  
— HOR DEF Circuit —

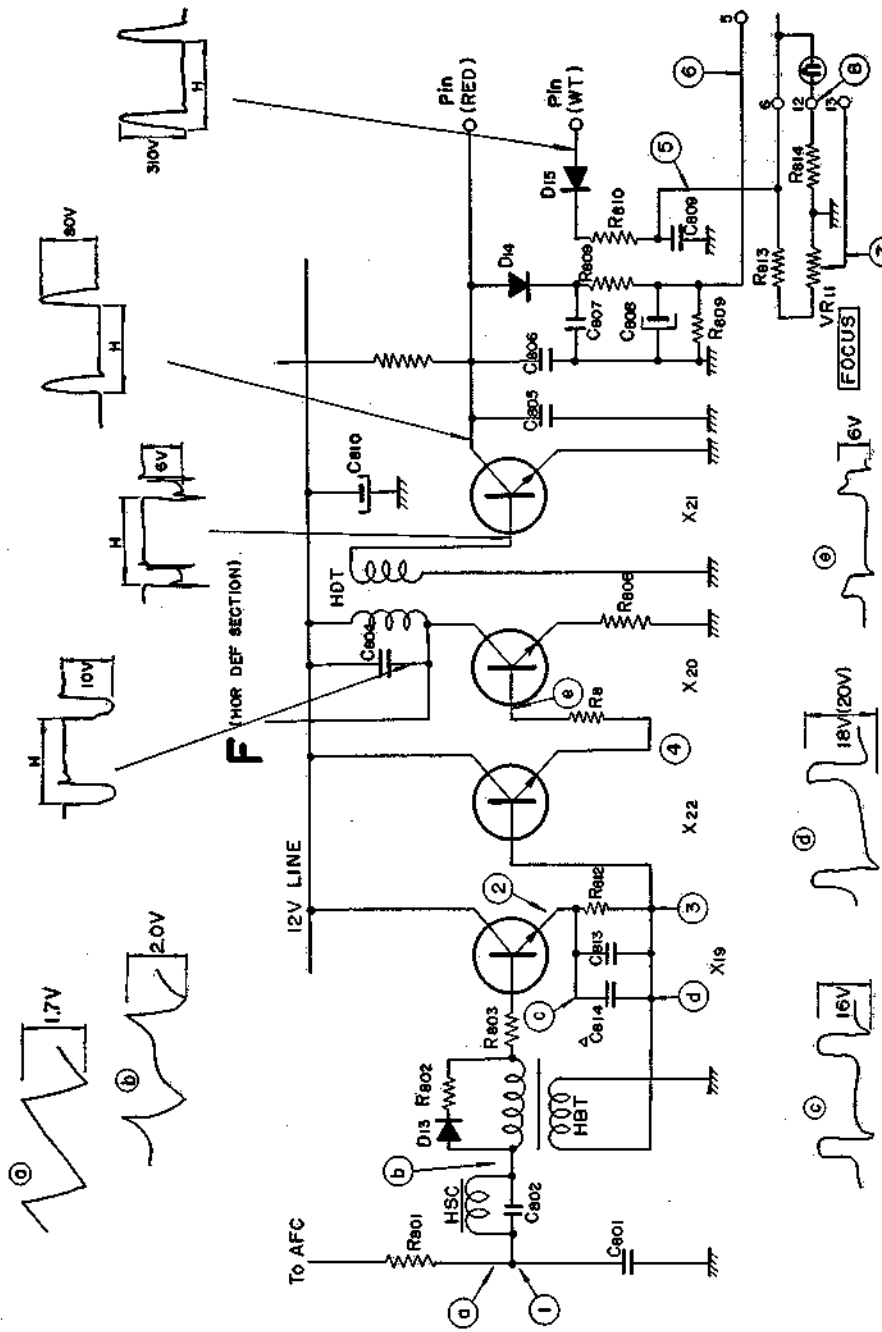

(Fig. 11)

**REMARKS FOR THE ELECTRICAL PARTS LIST ON PAGE 10 & 11.**

- Parts No. of Resistor
- 1—201— Composition Resistor
  - 1—203— Carbon Resistor
  - 1—207— Wire Wound Resistor

DC Voltage: ①...2.1V, ②...2.7V, ③...0.02V, ④...1.7V  
⑤...290V, ⑥...50V, ⑦...50~100V, ⑧...230V

# Electrical Parts List (A) for TV 5-303E

(Refer to the REMARKS on page 9)

Part No.	Symbol	Description	Part No.	Symbol	Description
1-221-276-11	VR <sub>2</sub>	<b>Potentiometer</b> Volume Control 5 KΩ-T	1-201-133-00	R <sub>409</sub>	1 KΩ RC1/8L
-275-11	VR <sub>3</sub>	Contrast Control 500Ω-E	1-203-373-00	R <sub>410</sub>	3.3 KΩ RD1/8L
-265-11	VR <sub>4</sub>	Brightness Control 250 KΩ-B	-373-00	R <sub>411</sub>	3.3 KΩ "
-297-11	VR <sub>5</sub>	Horizontal Hold Control 10 KΩ-B	-367-00	R <sub>412</sub>	1 KΩ "
-297-11	VR <sub>6</sub>	Vertical Hold Control 10 KΩ-B	-361-00	R <sub>415</sub>	470Ω "
-335-00	VR <sub>7</sub>	Vertical Height Control 1 KΩ-B	-385-00	R <sub>414</sub>	18 KΩ "
-326-00	VR <sub>8</sub>	Vertical Linearity Control 500Ω-B	-378-00	R <sub>415</sub>	5.6 KΩ "
-327-00	VR <sub>9</sub>	Vertical Bias Control 10 KΩ-B	-405-00	R <sub>416</sub>	1.5 KΩ "
-327-00	VR <sub>10</sub>	Horizontal Frequency Control- 10 KΩ-B	-351-00	R <sub>417</sub>	5.1 Ω "
1-221-351-00	VR <sub>11</sub>	Focus Control 600 KΩ-B	-370-00	R <sub>418</sub>	2.2 KΩ "
1-101-406-01	CR <sub>301</sub>	<b>Encapsulated Component</b> 1.2 KΩ, 0.01 μF, 0.01 μF	-011-00	R <sub>419</sub>	100Ω RD1/4L
-406-01	CR <sub>302</sub>	"	-356-00	R <sub>420</sub>	75 Ω RD1/8RL
-406-01	CR <sub>303</sub>	"	-315-00	R <sub>421</sub>	10 Ω "
-406-01	CR <sub>304</sub>	"	-368-00	R <sub>422</sub>	1.2 KΩ RD1/8RL
-406-01	CR <sub>401</sub>	"	-368-00	R <sub>423</sub>	1.2 KΩ "
1-201-454-11	R <sub>101</sub>	<b>Resistor</b> 560Ω RC1/4L	-366-00	R <sub>424</sub>	820Ω "
1-203-095-00	R <sub>102</sub>	27 KΩ RD1/4L	-308-00	R <sub>425</sub>	18 Ω "
1-203-187-00	R <sub>202</sub>	6.8 KΩ RD1/16L	-308-00	R <sub>426</sub>	18 Ω "
-187-00	R <sub>203</sub>	6.8 KΩ "	-006-00	R <sub>427</sub>	27 Ω RD1/4L
-182-00	R <sub>203</sub>	1 KΩ "	-334-00	R <sub>428</sub>	180Ω "
-184-00	R <sub>204</sub>	2.2 KΩ "	-400-00	R <sub>501</sub>	120 KΩ RD1/8RL
-187-00	R <sub>205</sub>	6.8 KΩ RD1/16L	-386-00	R <sub>502</sub>	15 KΩ "
-185-00	R <sub>206</sub>	4.7 KΩ "	-375-00	R <sub>503</sub>	4.3 KΩ "
-192-00	R <sub>207</sub>	15 KΩ "	-377-00	R <sub>504</sub>	5.1 KΩ "
-182-00	R <sub>208</sub>	1 KΩ "	-370-00	R <sub>505</sub>	2.2 KΩ "
-421-00	R <sub>209</sub>	1 KΩ RD1/16RL	-354-00	R <sub>506</sub>	33 Ω "
-425-00	R <sub>210</sub>	3.3 KΩ RD1/16L	-367-00	R <sub>507</sub>	1 KΩ "
-185-00	R <sub>211</sub>	4.7 KΩ "	-408-00	R <sub>508</sub>	8.2 KΩ "
-190-00	R <sub>212</sub>	10 KΩ "	-383-00	R <sub>509</sub>	10 KΩ "
1-201-160-00	R <sub>213</sub>	42Ω RC1/10L	-100-00	R <sub>510</sub>	100 KΩ RD1/4L
1-203-181-00	R <sub>214</sub>	390Ω RD1/16L	1-201-596-00	R <sub>511</sub>	3.3 MΩ RC1/2L
-181-00	R <sub>215</sub>	390Ω "	1-203-011-00	R <sub>512</sub>	100Ω RD1/4RL
-339-00	R <sub>216</sub>	1.8 KΩ RD1/16RL	-387-00	R <sub>601</sub>	22 KΩ RD1/8L
-187-00	R <sub>217</sub>	6.8 KΩ RD1/16L	-383-00	R <sub>602</sub>	10 KΩ "
-185-00	R <sub>218</sub>	4.7 KΩ "	-759-00	R <sub>603</sub>	120 KΩ "
1-201-457-00	R <sub>301</sub>	1.2 KΩ RC1/8L	-411-00	R <sub>604</sub>	330 KΩ "
1-203-145-00	R <sub>302</sub>	150Ω RD1/8RL	1-203-377-00	R <sub>605</sub>	5.1 KΩ RD1/8RL
-357-00	R <sub>303</sub>	100Ω "	-383-00	R <sub>606</sub>	10 KΩ "
1-201-123-00	R <sub>304</sub>	6.8 KΩ RC1/8L	-368-00	R <sub>608</sub>	1.2 KΩ "
1-203-414-00	R <sub>305</sub>	47Ω RD1/8RL	-368-00	R <sub>609</sub>	1.2 KΩ "
1-201-108-00	R <sub>306</sub>	10 KΩ RC1/8L	-368-00	R <sub>610</sub>	1.2 KΩ "
1-203-414-00	R <sub>307</sub>	47Ω RD1/8RL	-561-00	R <sub>611</sub>	1.2 KΩ "
-368-00	R <sub>309</sub>	1.2 KΩ "	-387-00	R <sub>612</sub>	100Ω "
-373-00	R <sub>309</sub>	3.3 KΩ "	-385-00	R <sub>613</sub>	1.2 KΩ RD1/8RL
1-203-414-00	R <sub>310</sub>	47Ω RD1/8RL	-378-00	R <sub>614</sub>	470Ω "
-368-00	R <sub>312</sub>	1.2 KΩ "	-405-00	R <sub>615</sub>	22 KΩ "
-370-00	R <sub>313</sub>	2.2 KΩ "	-397-00	R <sub>701</sub>	15 KΩ "
-412-00	R <sub>314</sub>	390Ω "	-360-00	R <sub>702</sub>	5.6 KΩ "
-357-00	R <sub>315</sub>	100Ω "	-360-00	R <sub>703</sub>	1.5 KΩ "
-383-00	R <sub>316</sub>	10 KΩ "	-377-00	R <sub>704</sub>	82 KΩ "
-361-00	R <sub>317</sub>	470Ω RD1/8RL	-377-00	R <sub>705</sub>	330Ω "
-372-00	R <sub>318</sub>	2.7 KΩ "	1-207-018-00	R <sub>706</sub>	5.1 KΩ "
-368-00	R <sub>319</sub>	1.2 KΩ "	R <sub>707</sub>	3Ω RW1/4RL	
-404-00	R <sub>320</sub>	200Ω "	1-203-367-00	R <sub>708</sub>	1 KΩ RD1/8RL
1-201-122-00	R <sub>321</sub>	4.3 KΩ RC1/8L	-778-00	R <sub>709</sub>	2.4 KΩ "
1-203-366-00	R <sub>322</sub>	820Ω RD1/8RL	-375-00	R <sub>710</sub>	4.3 KΩ "
1-201-128-00	R <sub>323</sub>	33Ω RC1/8L	-316-00	R <sub>711</sub>	510Ω "
-128-00	R <sub>325</sub>	33Ω "	-335-00	R <sub>712</sub>	750Ω "
-128-00	R <sub>326</sub>	33Ω "	1-207-018-00	R <sub>713</sub>	3Ω RW1/4RL
1-203-884-00	R <sub>327</sub>	33 KΩ RD1/16L	1-203-857-00	R <sub>714</sub>	620Ω RD1/8RL
-380-00	R <sub>401</sub>	6.2 KΩ RD1/8RL	1-201-147-00	R <sub>715</sub>	18 KΩ RC1/8L
-373-00	R <sub>402</sub>	3.3 KΩ "	1-203-382-00	R <sub>716</sub>	7.5 KΩ RD1/8RL
1-201-123-00	R <sub>403</sub>	6.8 KΩ RC1/8L	-443-00	R <sub>801</sub>	3 KΩ RD1/8RL
1-203-367-00	R <sub>404</sub>	1 KΩ RD1/8RL	-857-00	R <sub>802</sub>	620Ω "
-381-00	R <sub>405</sub>	6.8 KΩ "	-760-00	R <sub>803</sub>	430Ω "
-381-00	R <sub>406</sub>	6.8 KΩ "	1-203-360-00	R <sub>804</sub>	330Ω RD1/8RL
1-203-375-00	R <sub>408</sub>	4.3 KΩ RD1/8RL	1-207-022-00	R <sub>806</sub>	5.6Ω RW1/4RL
			1-203-386-00	R <sub>807</sub>	18 KΩ RD1/8RL
			-384-00	R <sub>808</sub>	12 KΩ "
			-399-00	R <sub>809</sub>	100 KΩ "



—continued—

Part No.	Symbol	Description	Part No.	Symbol	Description
1-203-031-00	R <sub>818</sub>	1 K $\Omega$ RD1/4L	1-101-004-01	C <sub>405</sub>	0.01 $\mu$ F Ceramic
	R <sub>811</sub>		-004-01	C <sub>406</sub>	0.01 $\mu$ F "
1-203-367-00	R <sub>812</sub>	1 K $\Omega$ RD1/8RL	-085-01	C <sub>407</sub>	6 PF "
-867-00	R <sub>813</sub>	390 K $\Omega$ "	-129-01	C <sub>408</sub>	40 PF "
-868-00	R <sub>814</sub>	620 K $\Omega$ "	-004-01	C <sub>409</sub>	0.01 $\mu$ F "
				C <sub>410</sub>	—deleted—
1-201-455-11	R <sub>901</sub>	1.5 M $\Omega$ RC1/2L	1-103-023-11	C <sub>411</sub>	400 PF Styrol
1-203-148-00	R <sub>902</sub>	47 $\Omega$ RD1/4L	1-101-118-01	C <sub>412</sub>	0.01 $\mu$ F Ceramic
1-201-455-11	R <sub>903</sub>	1.5 M $\Omega$ RC1/2L	-118-01	C <sub>413</sub>	0.01 $\mu$ F "
		Capacitor	-086-01	C <sub>414</sub>	0.1 $\mu$ F "
1-101-001-01	C <sub>101</sub>	0.001 $\mu$ F Ceramic	1-121-104-01	C <sub>415</sub>	10 $\mu$ F 6 WV Electrolytic
	C <sub>102</sub>	—deleted—	-102-01	C <sub>416</sub>	30 $\mu$ F "
1-101-001-01	C <sub>103</sub>	0.001 $\mu$ F Ceramic	-120-01	C <sub>417</sub>	100 $\mu$ F 12 WV "
		—deleted—	-128-01	C <sub>418</sub>	50 $\mu$ F 6 WV "
	C <sub>201</sub>	—deleted—	-122-01	C <sub>419</sub>	50 $\mu$ F 12 WV "
1-101-076-00	C <sub>202</sub>	0.5 PF Ceramic	-121-01	C <sub>420</sub>	200 $\mu$ F 12 WV "
-076-00	C <sub>203</sub>	0.5 PF "			
-041-00	C <sub>204</sub>	50 PF "	1-121-118-01	C <sub>501</sub>	10 $\mu$ F 12WV Electrolytic
1-141-055-00	C <sub>205</sub>	Cylindrical Trimmer Capacitor	-118-01	C <sub>502</sub>	10 $\mu$ F "
-055-00	C <sub>210</sub>	" " "	1-105-033-00	C <sub>503</sub>	0.005 $\mu$ F Mylar (MFL)
-055-00	C <sub>211</sub>	" " "	1-121-155-01	C <sub>504</sub>	100 $\mu$ F 6 WV Electrolytic
-055-00	C <sub>212</sub>	" " "	1-105-077-00	C <sub>505</sub>	0.2 $\mu$ F Mylar (MFL)
-055-00	C <sub>224</sub>	" " "	-035-00	C <sub>506</sub>	0.05 $\mu$ F " "
-055-00	C <sub>225</sub>	" " "	-036-00	C <sub>507</sub>	0.05 $\mu$ F " "
1-101-039-00	C <sub>206</sub>	10 PF Ceramic	1-127-906-00	C <sub>601</sub>	1 $\mu$ F 10 WV Electrolytic (Alox)
-040-00	C <sub>207</sub>	20 PF "	-907-00	C <sub>602</sub>	3 $\mu$ F 6 WV " "
-043-00	C <sub>208</sub>	0.001 $\mu$ F "	1-105-035-00	C <sub>603</sub>	0.05 $\mu$ F Mylar (MFL)
-036-00	C <sub>209</sub>	3 PF "	1-127-906-00	C <sub>604</sub>	1 $\mu$ F 10 WV Electrolytic (Alox)
-039-00	C <sub>212</sub>	10 PF "	1-105-018-00	C <sub>605</sub>	0.03 $\mu$ F Mylar (MFL)
-035-00	C <sub>213</sub>	2 PF "	-063-00	C <sub>606</sub>	0.01 $\mu$ F " "
-043-00	C <sub>214</sub>	0.001 $\mu$ F "	1-127-906-00	C <sub>607</sub>	1 $\mu$ F 10 WV Electrolytic (Alox)
-041-00	C <sub>215</sub>	50 PF "		C <sub>608</sub>	—deleted—
1-141-054-00	C <sub>216</sub>	Cylindrical Trimmer Capacitor (Fine Tuning)	1-105-076-00	C <sub>609</sub>	0.1 $\mu$ F Mylar (MFL)
			-076-00	C <sub>610</sub>	0.1 $\mu$ F " "
1-101-067-00	C <sub>217</sub>	3 PF Ceramic	1-127-908-00	C <sub>611</sub>	3 $\mu$ F 10 WV Electrolytic (Alox)
-043-00	C <sub>219</sub>	0.001 $\mu$ F "			
-044-00	C <sub>220</sub>	0.005 $\mu$ F "	1-127-905-01	C <sub>701</sub>	5 $\mu$ F 10 WV Electrolytic (Alox)
-040-00	C <sub>221</sub>	20 PF "	1-121-141-05	C <sub>702</sub>	100 $\mu$ F 12 WV Electrolytic
-038-00	C <sub>222</sub>	5 PF "	-118-01	C <sub>703</sub>	10 $\mu$ F " "
-020-00	C <sub>223</sub>	0.005 $\mu$ F "	-122-00	C <sub>704</sub>	50 $\mu$ F " "
	C <sub>224</sub>	—deleted—	-161-05	C <sub>705</sub>	500 $\mu$ F 6 WV "
1-101-041-00	C <sub>227</sub>	50 PF Ceramic	-122-00	C <sub>706</sub>	50 $\mu$ F 12 WV "
-645-00	C <sub>301</sub>	10 PF Ceramic	-164-00	C <sub>707</sub>	10 $\mu$ F " "
-004-01	C <sub>302</sub>	0.01 $\mu$ F "	-136-00	C <sub>708</sub>	2 $\mu$ F 50 WV "
1-121-106-01	C <sub>303</sub>	5 $\mu$ F 6 WV Electrolytic	1-105-037-00	C <sub>709</sub>	0.2 $\mu$ F Mylar (MFL)
1-101-046-01	C <sub>304</sub>	2 PF Ceramic			
-114-01	C <sub>305</sub>	15 PF "	1-105-034-00	C <sub>801</sub>	0.02 $\mu$ F Mylar (MFL)
-046-01	C <sub>306</sub>	2 PF "	-035-00	C <sub>802</sub>	0.05 $\mu$ F " "
-111-00	C <sub>307</sub>	20 PF "		C <sub>803</sub>	—deleted—
-004-01	C <sub>308</sub>	0.01 $\mu$ F "	1-105-076-00	C <sub>804</sub>	0.1 $\mu$ F Mylar (MFL)
1-121-145-01	C <sub>309</sub>	1 $\mu$ F 6WV Electrolytic	1-113-112-00	C <sub>805</sub>	0.04 $\mu$ F PS
1-101-036-01	C <sub>310</sub>	3 PF Ceramic	-107-00	C <sub>806</sub>	0.02 $\mu$ F "
-114-00	C <sub>311</sub>	15 PF "	1-105-035-00	C <sub>807</sub>	0.05 $\mu$ F Mylar (MFL)
-004-01	C <sub>312</sub>	0.01 $\mu$ F "	1-121-148-01	C <sub>808</sub>	1 $\mu$ F 100 WV Electrolytic
1-121-106-01	C <sub>313</sub>	5 $\mu$ F 6 WV Electrolytic	1-115-046-00	C <sub>809</sub>	0.05 $\mu$ F 400 WV Oil
1-101-046-01	C <sub>314</sub>	2 PF Ceramic		C <sub>810</sub>	—deleted—
-649-01	C <sub>315</sub>	12 PF "		C <sub>811</sub>	—deleted—
1-121-106-01	C <sub>316</sub>	5 $\mu$ F 6 WV Electrolytic		C <sub>812</sub>	—deleted—
1-101-004-01	C <sub>317</sub>	0.01 $\mu$ F Ceramic	1-105-035-00	C <sub>813</sub>	0.05 $\mu$ F Mylar (MFL)
1-121-128-01	C <sub>318</sub>	50 $\mu$ F 6 WV Electrolytic	-063-00	C <sub>814</sub>	0.01 $\mu$ F " "
1-101-046-01	C <sub>319</sub>	2 PF Ceramic	1-109-010-00	C <sub>901</sub>	200 PF Mica
-645-00	C <sub>320</sub>	10 PF "	-010-00	C <sub>902</sub>	200 PF "
1-121-121-01	C <sub>321</sub>	200 $\mu$ F 12 WV Electrolytic	1-119-071-05	C <sub>903</sub>	4000 $\mu$ F 15 WV Electrolytic
1-101-069-01	C <sub>322</sub>	4 PF Ceramic	-071-05	C <sub>904</sub>	4000 $\mu$ F " "
1-103-096-00	C <sub>323</sub>	6 PF Styrol	-101-05	C <sub>905</sub>	100 $\mu$ F 12 WV "
1-101-424-00	C <sub>324</sub>	500 PF Ceramic	1-119-043-05	C <sub>906</sub>	200 $\mu$ F " "
-058-01	C <sub>325</sub>	0.005 $\mu$ F "	1-131-002-11	C <sub>907</sub>	50 $\mu$ F " " (Tantalum)
-004-01	C <sub>328</sub>	0.01 $\mu$ F "	1-127-909-11	C <sub>908</sub>	0.5 $\mu$ F 25 WV " (Alox)
-086-01	C <sub>327</sub>	0.1 $\mu$ F "			
1-121-116-01	C <sub>329</sub>	1 $\mu$ F 12 WV Electrolytic			
1-101-004-01	C <sub>330</sub>	0.01 $\mu$ F Ceramic			
-112-01	C <sub>401</sub>	50 PF Ceramic	X <sub>201</sub>	2SA161 (RF AMP)	
-004-01	C <sub>402</sub>	0.01 $\mu$ F "	X <sub>202</sub>	2SA161 (MIX)	
-069-01	C <sub>403</sub>	4 PF "	X <sub>203</sub>	2SA161 (OSC)	
-319-01	C <sub>404</sub>	0 PF "	X <sub>1</sub>	2SA70 (1st VIF AMP)	
			X <sub>2</sub>	2SA70 (2nd VIF AMP)	
			X <sub>3</sub>	2SA70 (3rd VIF AMP)	
			X <sub>4</sub>	2SA70 (4th VIF AMP)	

Part No.	Symbol	Description	Part No.	Symbol	Description
	X <sub>5</sub>	2SA70 (AGC AMP)			Thermistor
	X <sub>6</sub>	2SC73 (DC AMP)	1-800-001-00	Th <sub>201</sub>	S-10
	X <sub>7</sub>	2SA70 (1st SIF AMP)	8-860-003-00	Th <sub>401</sub>	S-90
	X <sub>8</sub>	2SA70 (2nd SIF AMP)	-005-00	Th <sub>701</sub>	S-300
	X <sub>9</sub>	2SD64 (AF DRIVE AMP)			HV Rectifier
	X <sub>10</sub>	2SB52 (AF POWER AMP)	1-525-039-00		IDKI
	X <sub>11</sub>	2SB52 ( // )			Coil and Transformers
	X <sub>12</sub>	2SA60 (VD DRIVE)	1-403-401-00	VIFT <sub>1</sub>	Video IF Transformer
	X <sub>13</sub>	2SC15 (VD OUT)	-426-11	VIFT <sub>2</sub>	//
	X <sub>14</sub>	2SC73 (SYNC SEP. AMP, NOISE LIMIT)	-424-02	VIFT <sub>3</sub>	//
	X <sub>15</sub>	2SB52 (SYNC SPLIT)	-425-02	VIFT <sub>4</sub>	//
	X <sub>16</sub>	2SB51 (VERT OSC)	-417-02	VIFT <sub>5</sub>	//
	X <sub>17</sub>	2SB51 (VERT DRIVE)	-418-02	VIFT <sub>6</sub>	//
	X <sub>18</sub>	2SC140 (VERT POWER)	-419-02	VIFT <sub>7</sub>	//
	X <sub>19</sub>	2SC140 (HOR OSC)	-306-02	SIFT <sub>1</sub>	Sound IF Transformer
	X <sub>20</sub>	2SC140 (HOR DRIVE)	-310-02	SIFT <sub>2</sub>	//
	X <sub>21</sub>	2SC41 (HOR POWER)	-048-02	SIFT <sub>3</sub>	IF Transformer for FM Detector
	X <sub>22</sub>	2SD65 (HOR BUFFER)	X-44012-54-0	L <sub>201-204</sub>	Tuner Rotary Coil
		Diode	1-409-001-00	Trap <sub>201</sub>	Video IF Trap Coil
	D <sub>1</sub>	1T22	1-407-001-00	CH <sub>201</sub>	IF Choke Coil
	D <sub>2</sub>	1T26	-013-02	Trap <sub>1</sub>	Sound Signal Trap
	D <sub>3</sub>	1T26	1-403-420-00	DET	Video Detector Block
	D <sub>4</sub>	1T23A		BLOCK	
	D <sub>5</sub>	1T23A	1-423-048-00	SDT	Sound Driver Transformer
	D <sub>6</sub>	1T22	1-411-003-11	L <sub>501</sub>	Peaking Coil
	D <sub>7</sub>	1T26	-002-11	L <sub>502</sub>	Peaking Coil
	D <sub>8</sub>	1T22	-003-11	L <sub>601</sub>	Peaking Coil
	D <sub>9</sub>	1T22	1-421-013-11	L <sub>902</sub>	Horizontal Choke Coil
	D <sub>10</sub>	1T22	1-435-005-00	VBT	Vertical Blocking Transformer
	D <sub>11</sub>	1T22	1-421-106-01	VCH	Vertical Output Choke Coil
	D <sub>12</sub>	1T22	1-413-004-00	HSC	Stabilizing Coil for Horizontal Sweep
	D <sub>13</sub>	1T22	1-435-007-12	HBT	Horizontal Blocking Transformer
	D <sub>14</sub>	1S205	1-437-002-00	HDT	Horizontal Driver Transformer
	D <sub>15</sub>	1S125	1-439-003-01	HOT	Horizontal Output Transformer
	D <sub>16</sub>	S2A30	1-421-008-13	BCH	Filter Choke Coil for Power Supply
1-531-103-02	D <sub>17-20</sub>	Selenium Rectifier	1-441-063-11	PT	Power Transformer

### Electrical Parts List (B) for TV 5-303E

Part No.	Description	Q'ty	Part No.	Description	Q'ty
	<b>A. General</b>		4-002-710-00	Terminal Strip for Yoke	(3)
	<b>Cabinet &amp; Appearance Items</b>		1-535-009-00	Connector Tip D	(2)
1-507-047-00	Twin Earphone Jack	1	7-621-255-22	Screw ⊕ RK 2×4	(1)
-065-00	Antenna Jack Assembly	1	1-105-035-00	Mylar Capacitor 0.05 μF 100 WV	(1)
	<b>Main Block</b>		1-203-316-00	Carbon Resistor RD1/8RL 510Ω	(2)
1-502-068-00	Speaker	1		<b>High Voltage Block</b>	
1-526-052-03	Socket for Picture Tube	1	1-453-001-00	High Voltage Block Assembly, including	1
-02			4-002-698-00	High Voltage Block Case	(1)
1-507-203-00	Multi-Jack for Printed Circuit Board	2	-699-00	High Voltage Block Shield Plate	(1)
1-532-031-11	Fuse (0.2A)	1	-700-00	High Voltage Rectifier Mounting Plate	(1)
1-519-007-01	Neon Lamp	1	-701-00	High Voltage Block Holding Bracket	(1)
-02			-702-00	High Voltage Block Shield Case	(1)
1-513-176-00	Power Switch	1	1-526-102-01	Anode Connector	(1)
1-506-020-00	4 Pole Plug, including	1	4-002-711-02	Anode Connector Cover	(1)
1-533-009-00	Fuse Holder	(2)	-712-03	Anode Connector	(1)
1-514-081-11	Micro-Switch	1	1-439-003-00	Horizontal Output Transformer	(1)
4-002-713-01	Flat Leaf Actuator for Micro-Switch	1	1-525-039-00	High Voltage Rectifier Tube, 1DK1	(3)
1-536-039-00	Two Lug Tie Point for Pilot Lamp Lead	1	1-535-009-00	Connector Tip D	(4)
1-531-103-01	Selenium Rectifier	1		Diode S2A30	(1)
-02			1-101-034-00	Ceramic Capacitor 500 PF 6 KV	(3)
-03			7-622-105-01	Nut 2φ	(2)
1-536-045-11	2P Lug	1		High Voltage Block Case Fix Screw	(2)
	<b>Accessory</b>			<b>Deflection Block</b>	
1-504-010-02	Earphone	1	X-40029-62-1	Mounted Deflection Circuit Board	1
1-534-041-00	AC Power Cord	1	1-506-108-00	Circuit Connecting Pin	7
X-40029-06-1	Spare Fuse Assembly	1	1-538-111-01	Deflection Circuit Board	1
1-534-042-03	Extension Cord	1		<b>Video &amp; Sound Signal Block</b>	
	<b>Deflection Yoke</b>		X-40029-61-1	Mounted Video & Sound Signal Circuit Board	1
1-451-003-00	Deflection Yoke Assembly, including	1	1-538-110-02	Video & Sound Signal Circuit Board	1
4-002-703-00	Yoke Cover	(1)	1-506-108-00	Circuit Connecting Pin	2
-704-00	Yoke Core Clamp	(1)	1-507-103-00	Connector Tip K	4
-705-00	Centering Magnet Assembly (A)	(1)		<b>B. Tube</b>	
-706-00	// // // (B)	(1)		Picture Tube 140CB4	1
-707-00	Centering Magnet Holding Bracket	(1)	73110510	High Voltage Rectifier Tube, 1DK1	3
-708-00	Yoke Clamp	(1)	1-525-039-00		
-709-00	Spacer for Centering Magnet	(1)			

—continued—

Part No.	Description	Q'ty	Part No.	Description	Q'ty
	<b>C. Wires and Miscellaneous</b> (Minimum Q'ty for Ordering: Meter)			Two Conductor Cable (Shielded) 7/0.12×2	
	<b>Main Block</b>			Tinned Copper Wire 0.6φ	
	<b>P. V. C. Wires</b>			1.0φ	
	12/0.18 1.5φ Red			Braided Wire 16/14/0.08	
	" " Orange			<b>High Voltage Block &amp; Deflection Block</b>	
	" " Yellow			<b>P. V. C. Wires</b>	
	" " Green			0.6φ Yellow	
	" " Blue			16/0.12 Black	
	" " Gray			20/0.18 Black	
	" " White			12/0.18 (Polyethylene)	
	" " Purple			Thermo Contracting Plastic Tube Gray	
	" " Black			<b>Video &amp; Sound Signal Block</b>	
	20/0.18 2.0φ Black			<b>P. V. C. Wire</b>	
	" " Brown			16/0.12 1.6φ Black	
	" " Red			Two Conductor Cable 7/0.12×2	
	" " Gray				
	" " White				

Part No.	Description	Q'ty	Part No.	Description	Q'ty
Y-44012-55-1	Tuner Block	1	X-40029-62-1	Deflection Block (Mounted Circuit Board)	1
X-40029-61-1	Video & Sound Signal Block (Mounted Circuit Board)	1	1-453-001-01	High Voltage Block	1
			1-451-003-00	Deflection Yoke	1

### Mechanical Parts List for TV. 5-303E

Part No.	Description	Q'ty	Part No.	Description	Q'ty
	<b>A. General</b>		X-40026-04-8	Cabinet (Back) Assembly	1
	<b>Cabinet &amp; Appearance Items</b>		4-002-795-03	Case Label	1
X-40026-02-0	Cabinet (Front) Assembly, including	1	-714-00	Telescopic Antenna Catch	1
4-002-603-02	Cabinet (Front)	(1)	X-40026-05-0	Carrying Handle Assembly, including	1
-604-01	Picture Tube Mask	(3)	4-002-620-01	Carrying Handle	(1)
-765-01	Picture Tube Protector	1	-622-00	Ornamental Leather for Handle	(2)
-611-00	Antenna Bushing	1	-733-00	Carrying Handle Holding Screw	(2)
-781-00	Dust-Proof Rubber	1	X-40026-06-2	Table Stand Assembly	1
-782-00	Spacer (Upper) for Picture Tube	1	-730-00	Rubber Foot	2
-783-00	Spacer (Lower) for Picture Tube	1	X-40026-43-0	Channel Selector Knob Assembly	1
-784-00	Deflection Yoke Spacer	1	X-40026-10-2	Fine Tuning Knob Assembly	1
X-40026-50-0	Picture Tube Clamp Assembly, including	1	X-40026-11-0	Volume Control Knob Assembly	1
4-002-778-00	Picture Tube Clamp	(1)	4-002-635-00	Control Knob (Hor. Hold. Brightness, Contrast)	3
-779-00	Picture Tube Fixing Bracket	(2)	-762-00	Vertical Hold Control Knob	1
-780-00	Grounding Metal for Picture Tube	(1)	-742-00	"SONY" Badge	1
X-40026-41-1	Telescopic Antenna Assembly, including	1	-761-00	Control Panel	1
4-002-716-00	Telescopic Antenna Holding Bracket	(1)		<b>Main Block</b>	
-718-00	Telescopic Antenna Connecting Lug	(3)	X-40026-14-4	Chassis Assembly	1
-715-00	Compressed Fiber Washer for Tele- scopic Antenna	(1)	X-40026-15-4	Speaker Holding Plate Assembly, including	1
-717-00	Telescopic Antenna Bottom Insulator	(1)	4-002-644-04	Speaker Holding Plate	(1)
-727-00	Telescopic Antenna Holding Nut	(3)	-646-01	Earpiece Jack Plate	(1)
-728-00	Lock Nut for Telescopic Antenna	(1)	-647-00	Multi-Jack Holding Bracket	(2)
7-623-412-01	Lock Washer (5φ) for Telescopic Antenna	(1)	-648-01	Adjustable Clamp for Electrolytic Capacitor	(1)
4-002-764-00	Telescopic Antenna Tip	(1)	X-40026-16-2	4 Pole Plug Mounting Bracket Assembly	1
			4-002-653-01	Micro-Switch Contacting Pin	1

Part No.	Description	Q'ty	Part No.	Description	Q'ty
4-002-674-00	Micro-Switch Mounting Plate	1		Spring Washer	
-649-00	Neon Lamp Holder	1	7-623-210-22	4φ (for Carrying Handle)	2
X-40026-66-0	Video & Sound Signal Block Shield Plate Assembly	1	7-622-307-02	Nut 2.6φ (for Table Stand)	2
X-40026-01-0	Deflection Block Deflection Circuit Board Assembly, including	1	7-621-561-42	Main Block	
4-002-680-01	Heat Sink for Hor. Power Transistor (A)	(1)	-32	Screw	
-681-01	Heat Sink for Hor. Power Transistor (B)	(1)	-259-62	(+)K 3φ×6 (for Power Transformer)	1
-682-02	Heat Sink for Vert. Power Transistor (A)	(1)	-261-32	(+)K 3φ×5 (for 4 Pole Plug)	3
-683-00	Heat Sink for Vert. Power Transistor (B)	(1)		(+)P 2.6φ×10 (for Earphone)	2
-684-00	Insulator for Heat Sink (Vert.)	(1)	-42	(+)P 3φ×5 (for Multi-Jack, 4 Pole Plug, Speaker, High Voltage Block, Power Switch)	14
-685-00	Spacer for Heat Sink	(2)	-12	(+)P 3φ×6 (for Power Transformer)	1
-686-01	Black Sheet on Deflection Circuit Board	(1)	-22	(+)P 3φ×3 (for Neon Lamp Holder)	1
			-62	(+)P 3φ×4 (Adjustable Clamp for Electrolytic Capacitor)	2
	<b>Accessory</b>			(+)P 3φ×10 (for Adjustable Clamp for Electrolytic Capacitor)	1
X-44900-01-0	Polyethylene Bag for Silicone Cloth	1	-111-42	(-)R 3φ×6 (for Tuner)	2
4-002-766-00	Carrying Bag	1	-361-32	(-)F 3φ×5 (for Chassis Mask)	1
-775-00	Carton for Carrying Bag	1	4-002-737-00	(+)P 3φ×23 (for Selenium Rectifier)	1
-771-00	Foam Cushion for Carrying Bag	1			
-772-00	Styro-Foam Cushion (Back)	1		Lock Washer	
-773-00	" " (Bottom)	1	7-623-408-01	3φ (for Selenium Rectifier & Tuner)	7
-774-00	" " (Front)	1			
-769-00	Polyethylene Bag	1		Spring Washer	
-770-00	Polyethylene Bag for Carrying Bag	1	7-623-207-12	2.6φ (for Earphone)	2
-667-00	Accessory Case	1			
4-495-008-53	Instruction Manual	1	4-002-785-00	Washer	
4-002-796-50	Caution Card	1		3φ (for Video & Sound Signal Circuit Board)	1
				Nut	
	<b>B. Screws &amp; Washers</b>		7-622-107-02	2.6φ (for Earphone)	2
	(Minimum Q'ty for Ordering: 100 pcs.)				
	<b>Cabinet &amp; Appearance Items</b>			Deflection Block	
	<b>Screws</b>		7-621-261-52	Screws	
7-621-559-48	(+)K 2.6φ×6 (for Antenna Clamper)	1	-255-52	(+)P 3φ×8 (for Transistor)	2
-561-32	(+)K 3φ×5 (for Antenna Bushing)	5	-42	(+)P 2φ×8 (for Transistor)	4
-555-26	(+)K 2φ×4 (for "SONY" Badge)	2	-555-32	(+)P 2φ×6 (for Heat Sink)	2
-36	(+)K 2φ×5 (for Table Stand)	4		(+)K 2φ×5 (for Deflection Circuit Board)	3
-561-52	(+)K 3φ×8 (for Picture Tube Clamp)	2			
-555-22	(+)K 2φ×4 (for Table Stand)	2	7-623-408-01	Lock Washer	
-561-23	(+)K 3φ×4 (for Telescopic Antenna Holding Bracket)	1		3φ (for Transistor)	2
-555-38	(+)K 2φ×5 (for Control Panel)	1	7-622-108-02	Nuts	
-261-36	(+)P 3φ×5 (for Cabinet (Back))	4	-105-02	3φ (for Transistor)	2
-259-38	(+)P 2.6φ×5 (for Table Stand, Cabinet (Back))	7		2φ (for Transistor)	4
-262-22	(+)P 3φ×20 (for Picture Tube Clamp)	1			
-255-48	(+)P 2φ×6 (for Table Stand Cushion)	3		Video & Sound Signal Block	
-770-28	(+)B 2φ×5 (for Control Panel)	1		Screws	
4-002-741-00	(+)P 4φ×7 (for Carrying Handle)	2	7-621-261-52	(+)P 3φ×8 (for Video & Sound Signal Circuit Board)	1
			-32	(+)P 3φ×5 (for Video & Sound Signal Circuit Board)	1

## TV5-202E

### NOTE for TV 5-202E

SONY Micro TV Model 5-202E is specially made for the North European countries (Denmark, Norway and Sweden) and satisfies DEMKO, SEMKO and NEMKO Specifications. All the features of the 5-202E are entirely same as 5-303E, which is also made for Continental Europe except for the points explained below. Therefore please refer to the Servicing Guide for 5-303E when the set is repaired.

1. Difference between 5-202E and 5-303E.

	<u>5-202E</u> <u>Black</u>	<u>5-202E</u> <u>White</u>	<u>5-303E</u>
Battery Charger	NO	NO	Built-in
AC Power Cord	fixed	removable	removable

2. Parts List for 5-202E (Special Parts only)

<u>Part No.</u>	<u>Description</u>	<u>Q'ty per one set</u>
1-421-024-11	Filter Choke Coil	1
1-441-099-11	Power Transformer	1
1-506-056-11	4 Pole Plug for 5-202E (White)	1
X-40030-59-1	4 Pole Plug for 5-202E (Black)	1
1-532-037-11	Fuse 1.6A	1
1-534-055-11	AC Power Cord	1

**Schematic Diagram for Power Supply Block**

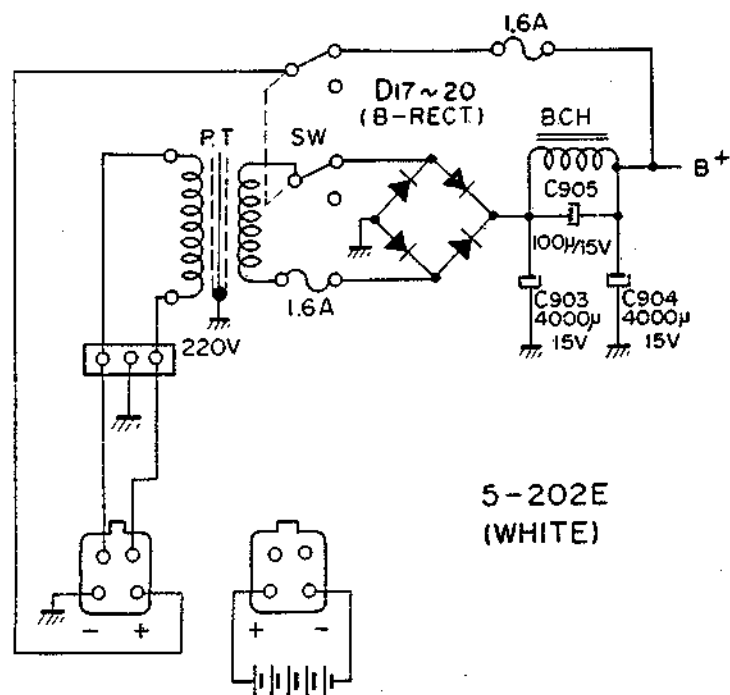
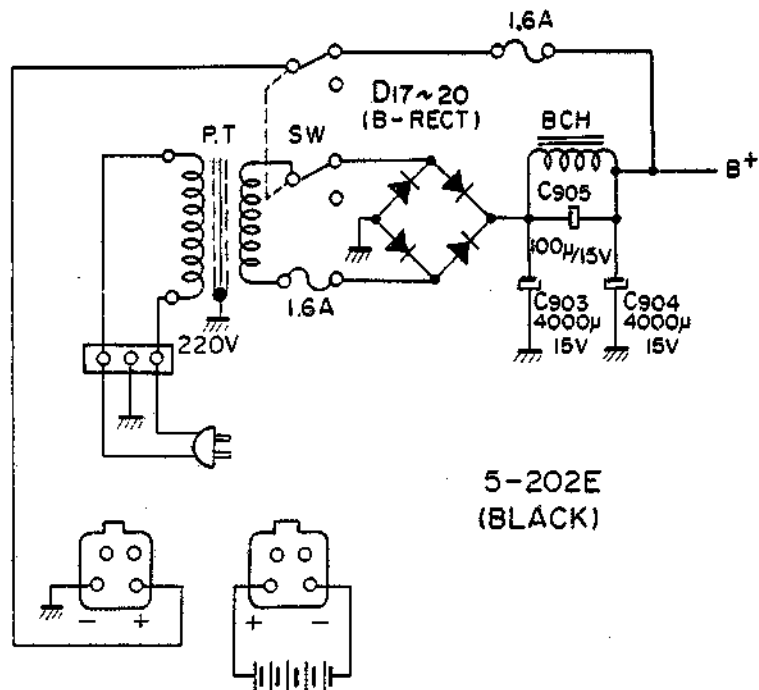

# 5-202E SCHEMATIC DIAGRAM

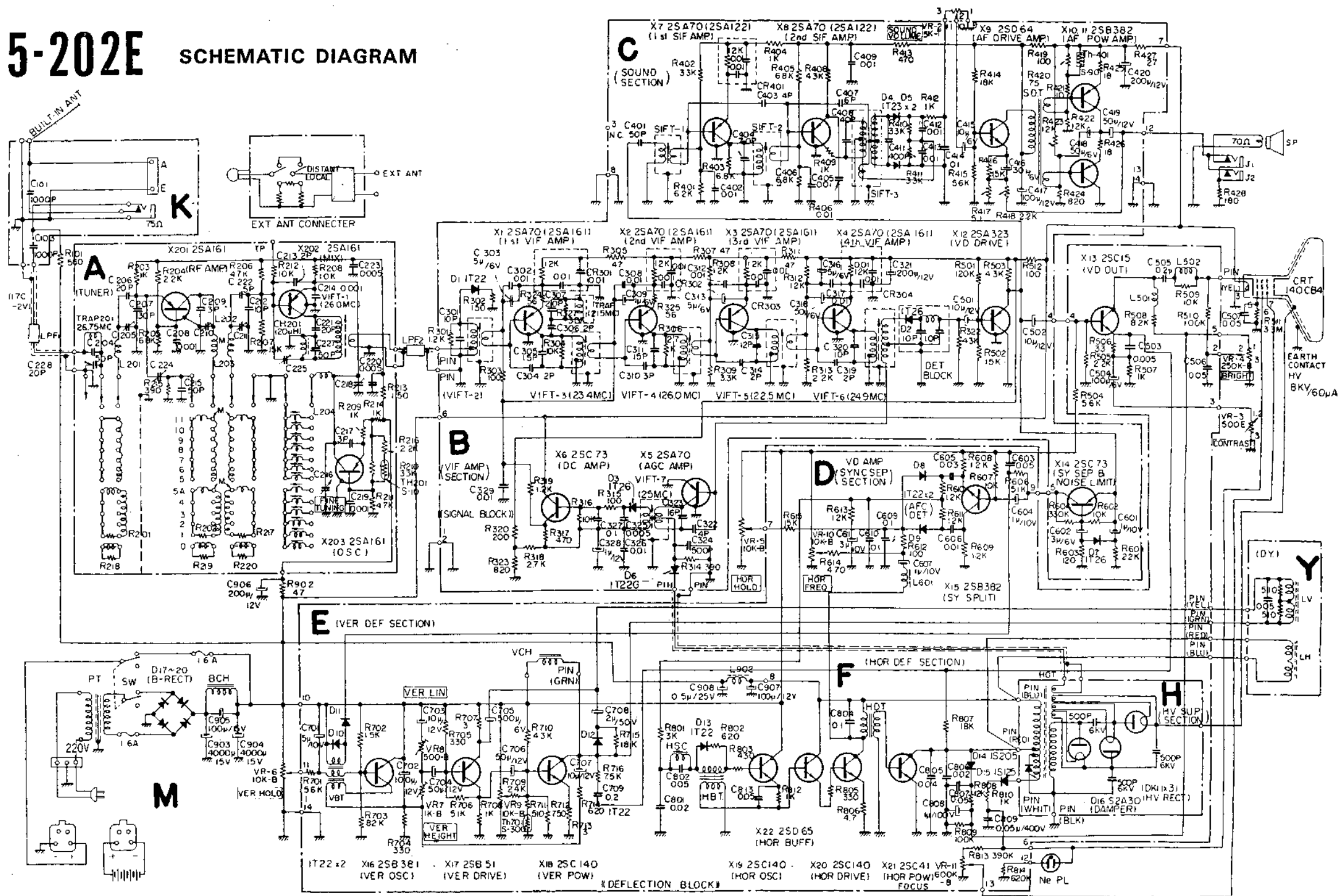

TV5-202E  
TV5-202V  
TV5-303E  
TV5-303T

# 5-202V SCHEMATIC DIAGRAM

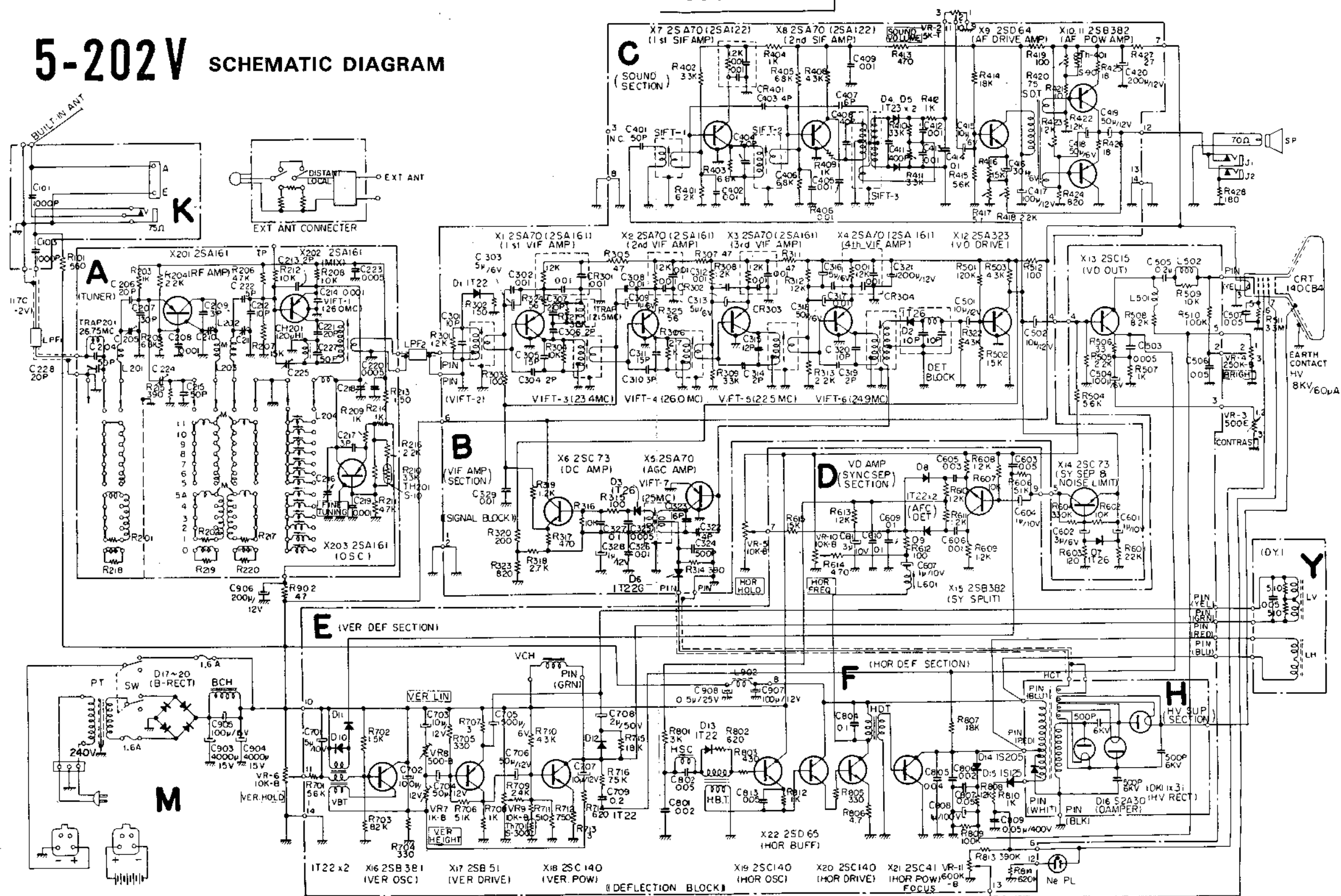

Sony Corporation

TV and Consumer Video Group

© 1965

B1C0406-7  
Printed in Japan

9-962-063-02



# TV5-303E&T



~ 202 714

B & W TV

E: For Continental Europe (excl. France, Monaco, Italy & OIRT members) T: For Italy

## Specifications

- Picture Tube:** 5", 70° Deflection, Aluminized Screen  
**Transistor:** 25 (5 Silicon—including 3 Epitaxial 20 Germanium)  
**Diode:** 20 (Including 4 Selenium)  
**Channel Coverage:** E-2 to E-11 (5-303E), A to H (5-303T)  
**Maximum Sensitivity:** 10 $\mu$ V (10Vpp at Picture Tube Cathode)  
**IF Circuit:** 4 Stages with 5 stagger tuned elements  
Video IF 26.75 Mc, Sound IF 21.25 Mc, Bandwidth 3.75 Mc/—3 dB~—6 dB  
**Resolution:** Vertical 400 lines, Horizontal 300 lines  
**Sound System:** 5.5 Mc Inter-carrier System  
Power Output Stage OTL System 150 mW.  
Speaker 3", 70 $\Omega$  Voice Coil  
**Automatic Control:** Pulse-operated AGC, Diode AFC,  
Sync. ANS (Automatic Noise Suppressor)  
**Power Requirement:** AC 220V, 50c/s, DC 12V Battery (3.5 AH)  
**Power Consumption:** AC 13W, DC 9.6W (0.8A)  
**Dimensions:** 7-5/8" (W)  $\times$  4-1/4" (H)  $\times$  7-1/4" (D)  
**Weight:** 8 lb  
**Glare Proofing:** Smoked Filter, 70% Transparency

**SONY**<sup>®</sup>  
**SERVICE MANUAL**

CONTENTS

Specifications for the SONY Micro-TV 5-303E and 5-303T ..... 1

THE SONY MICRO-TV MODEL 5-303E and 5-303T ..... 4

GENERAL ..... 4

THE TUNER ..... 7

SIGNAL CIRCUIT BOARD SECTION ..... 9

DEFLECTION CIRCUIT BOARD AND HIGH-VOLTAGE BLOCK SECTIONS ..... 11

POWER SUPPLY SECTION ..... 14

METHOD OF DISASSEMBLING THE SET ..... 15

To Remove the Front Control Panel ..... 15

To Remove the Back Cabinet Cover..... 15

To Remove the Telescopic Antenna and the Tuner..... 15

To Remove the Signal Circuit Board..... 16

To Remove the Deflection Circuit Board ..... 17

To Remove the Chassis from the Front Panel ..... 18

To Remove the Picture Tube..... 19

To Remove the High Voltage Block ..... 19

TROUBLE SHOOTING ..... 20

Raster ..... 20

Video Output and Synchronization ..... 22

Sound..... 24

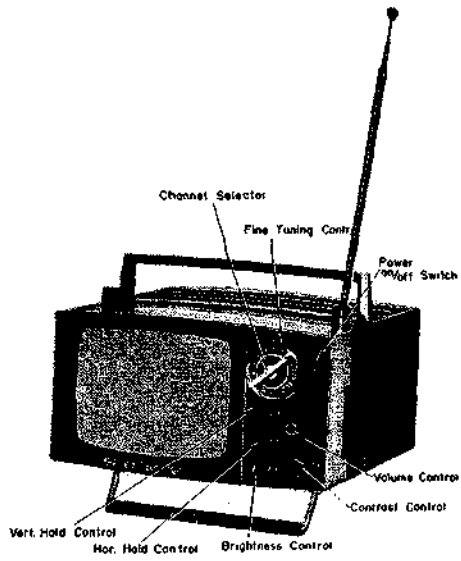

(Fig. 1)

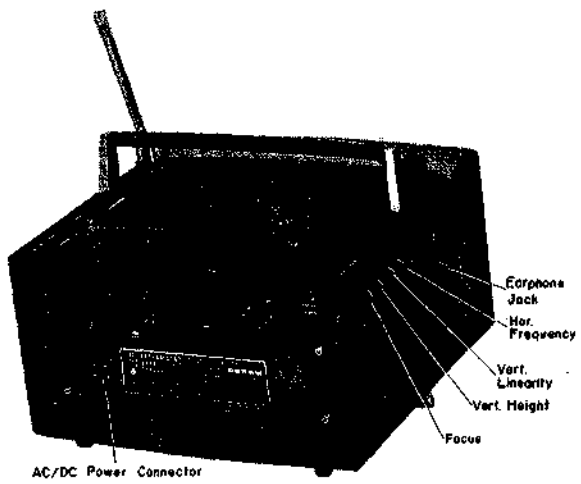

(Fig. 2)

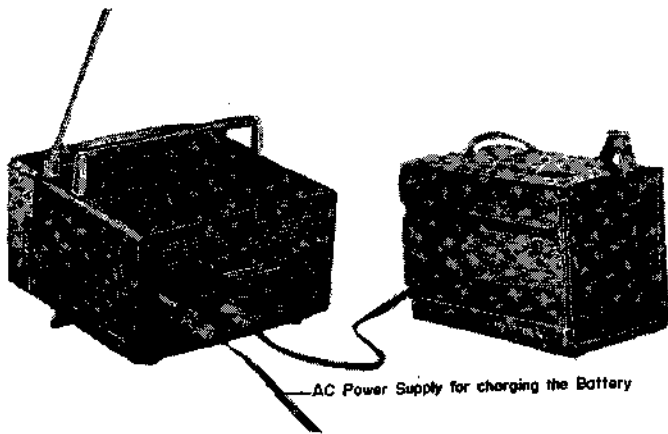

(Fig. 3)

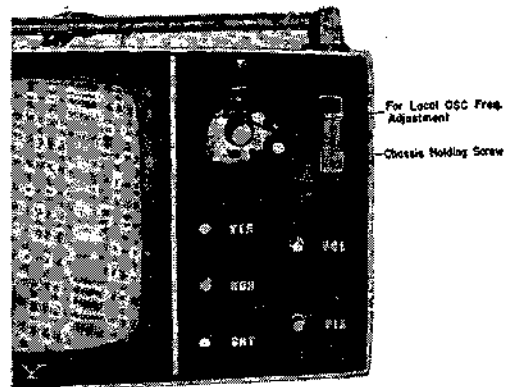

(Fig. 4)

## THE SONY MICRO-TV MODEL 5-303E and 5-303T

### General

The aim, in the designing of the SONY Micro-TV Model 5-303E (5-303T) was the creation of a completely new type of TV set which could be achieved only by the use of transistors.

The concrete requirements given to be met from the start of the design were as follows:

- 1) To be small in size and light in weight.
- 2) To have the lowest power consumption of any mass produced TV set.
- 3) To operate perfectly as a completely portable TV set under all conditions.
- 4) To provide facilities for easy servicing.

To fulfil these requirements, many developments and improvements were made on the components and the circuit arrangements as explained below

#### 1. Picture Tube 140CB4 (see Fig. 6)

The resolution of the picture depends greatly upon the construction of the picture tube, and the power consumption of the TV set is much influenced by the construction of the electron gun in the tube. Therefore, the key point of success in making a superior TV set is the improvement of the picture tube. The 140CB4 picture tube was specially developed for the SONY Micro-TV 5-303E (5-303T) and has the following features.

##### a) Resolution

Horizontal: 28 lines per cm. (300 lines for full picture)  
 Vertical: 45 lines per cm. (400 lines for full picture)

##### b) Deflection power

70 degree deflection and a neck diameter of 20 mm (3/4") result in lower deflection power although the anode voltage is as high as 8KV. This gives a brightness of 500 lux.

##### c) The power required for the heater is less than 1 watt.

##### d) The overall length of tube is only 161mm (6-5/16").

##### e) The cut-off voltage at the first grid is made very low by introducing techniques developed in transistor manufacturing into the assembly of the electron gun. Consequently, satisfactory contrast is obtained at lower video signal output.

##### f) The square corners of the tube give a larger picture for the size of the tube.

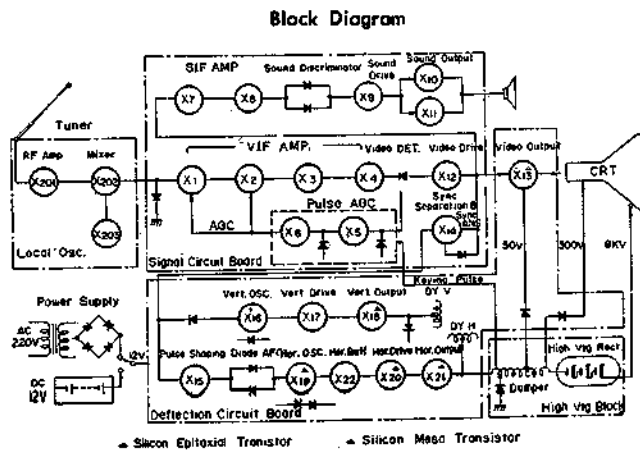

(Fig. 5)

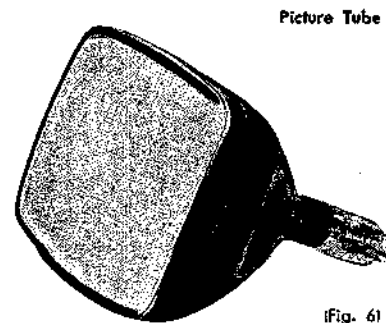

(Fig. 6)

#### Specifications of Picture Tube 140CB4

Type :	Rectangular Frame	Diagonal Dimension :	137 mm (5-3/8")
Neck Diameter :	20 mm (3/4")	Full Length :	161mm (6-5/16")

Deflection :	Electromagnetic	Focusing :	Electrostatic Automatic
Deflection Angle :	70-degree	Ion Trap :	Unnecessary
Heater Voltage :	12.0V, 70 mA	Anode Voltage :	8 KV
Anode Current :	50 $\mu$ A	2nd Grid Voltage :	300 V
Focusing Voltage :	0~120 V	1st Grid Cut-off Voltage :	Approx.—25 V

2. The SONY Epitaxial Transistor 2SC140 (See Fig. 7)

Silicon transistors have been used in high powered circuits in TV sets, such as Video Output Stage, Vertical Output Stage and for the Horizontal Oscillator, Horizontal Drive and Horizontal Output because of their higher working voltage, stable operation at high temperatures and lower  $I_{CSO}$  (Low Leakage Current). The disadvantage has been that the internal resistance (Collector Saturation Resistance,  $R_s$ ) was high (app. 70 $\Omega$ ) causing high power consumption. The new SONY Epitaxial Transistor of the Mesa Silicon Type was developed to overcome this disadvantage. The  $R_s$  of the 2SC140 is 2 $\Omega$ . Three of these special transistors are used in the Micro-TV Model 5-303E (5-303T). One each is used in the Vertical Output, Horizontal Oscillator and Horizontal Drive. One result of the use of these transistors is that the SONY Micro-TV will operate satisfactorily at an ambient temperature of 35°C (95°F).

**Brief Specifications of the SONY Epitaxial Transistor 2SC140**

Maximum Collector-Base Voltage :	60 V
Maximum Collector Current :	1A
Collector Dissipation (Max) :	1.7 W (without heat sink)
Collector Saturation Resistance ( $R_s$ ) :	2 $\Omega$
Maximum Junction Temperature :	175°C

3. Automatic Gain Control Circuit

The AGC system is of the pulse type and an Automatic Noise Suppression (ANS) circuit is included in the synchronizing pulse separation circuit. With the use of these circuit the SONY Micro-TV 5-303E (5-303T) will maintain synchronization even in a moving car where the signal strength varies suddenly and almost continuously, and even in the presence of strong engine noise radiation.

4. Provision for Easy Servicing

Small size usually means difficult servicing. The SONY Micro-TV Model 5-303E (5-303T) is divided into five sections for easy service. (See the Block Diagram shown in Fig. 5) The sections are: Tuner, Signal Circuit Board, Deflection Circuit Board, High Voltage Block and Power Supply. The Signal Circuit Board and the Deflection Circuit Board are of the Plug-in type so that either of these Boards may be removed as a unit and replaced with a new one for easy and rapid repairing.

Epitaxial Transistor

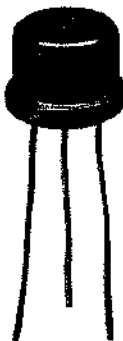

(Fig. 7)

Level Diagram for Video

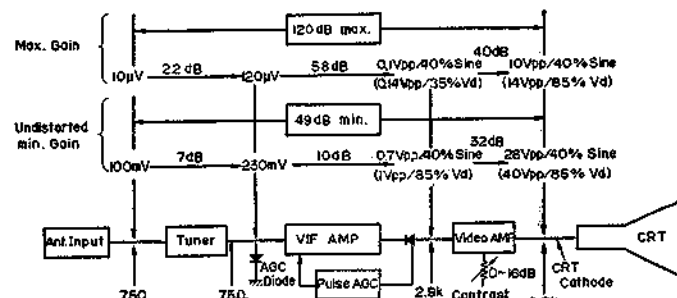

(Fig. 8)

For 5-303E

For 5-303T

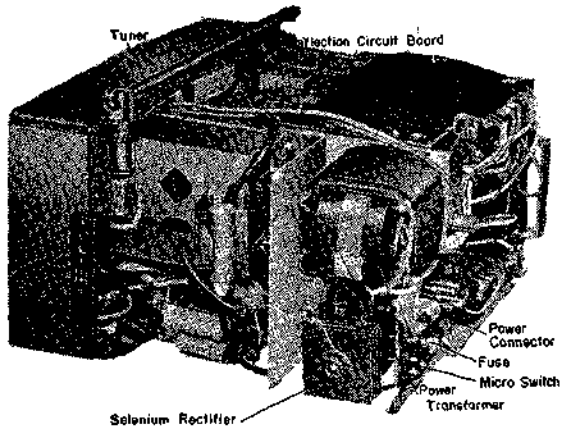

(Fig. 9-1)

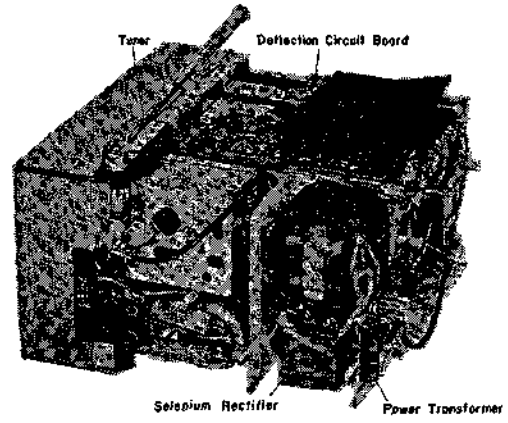

(Fig. 9-2)

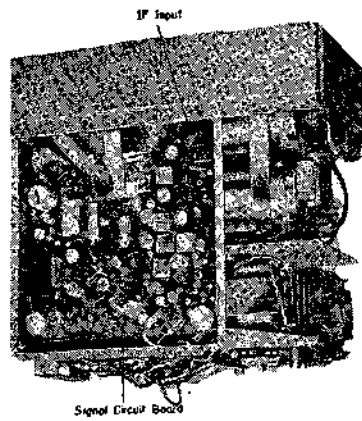

(Fig. 10-1)

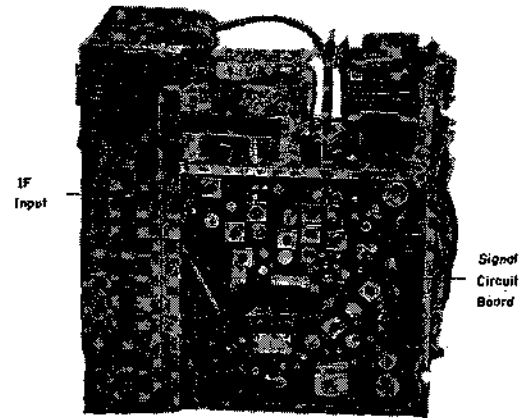

(Fig. 10-2)

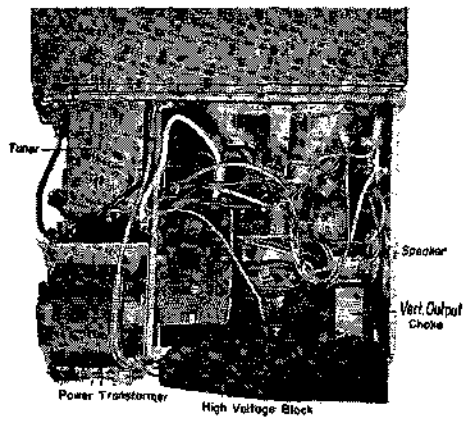

(Fig. 11-1)

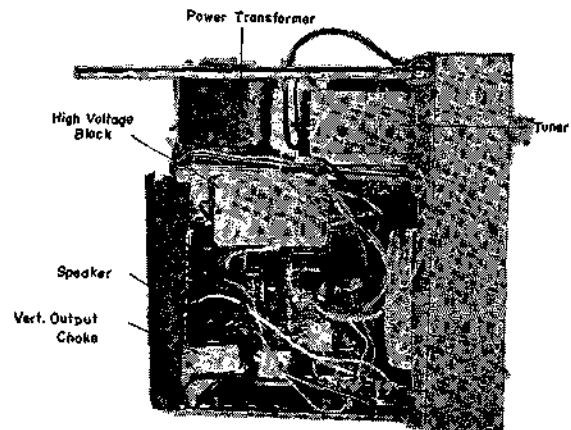

(Fig. 11-2)

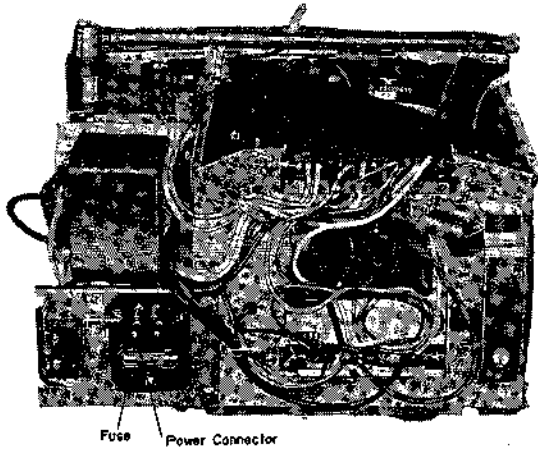

(Fig. 12)

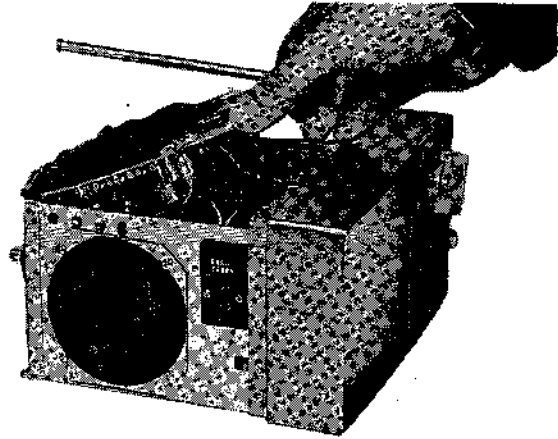

(Fig. 13)

### The Tuner

The Tuner uses three PNP Mesa Type Germanium Transistors (2SA161). One is used in the RF Amplifier, one in the Mixer and one in the Local Oscillator. A Disc Type Turret is used for mounting all the coils and contacts for Channel Selection. Special Contact Points have been designed for easy and positive channel selection. The Transistors and other circuit parts are mounted directly above the Channel Switch and are enclosed within the Tuner Shield. The RF coils for each channel are connected in series but the Oscillator Coil for each channel can be adjusted independently. The AGC characteristics of the set is excellent and though the Input Attenuator has been dispensed with, the set with the Telescopic Antenna extended to its full length can be operated at a field strength of as much as 100 mv/m without overloading the circuits. This maximum field strength allowable can be extended further to 1v/m by retracting the Telescopic Antenna. The AGC Diode (DI) acts as a load for the Tuner and limits the output of the tuner to prevent overloading of the following circuits when the signal input level to the tuner is high.

### Block Diagram of Tuner

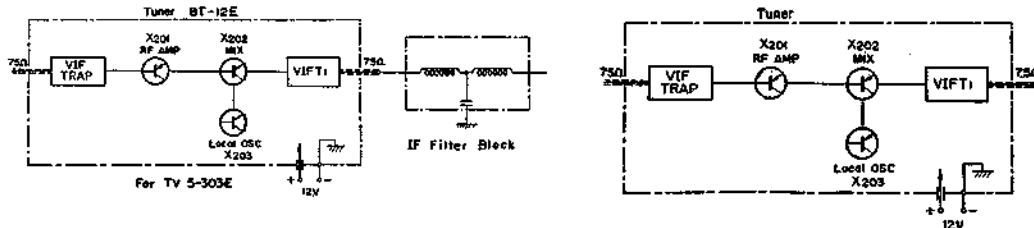

For 5-303E (Fig. 14-1)

For 5-303T (Fig. 14-2)

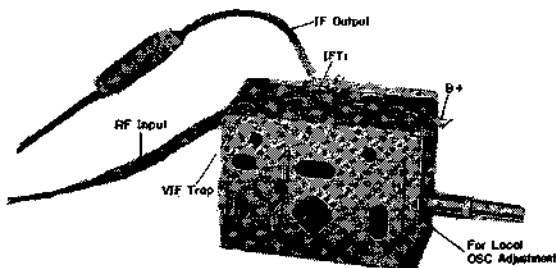

For 5-303E (Fig. 15-1)

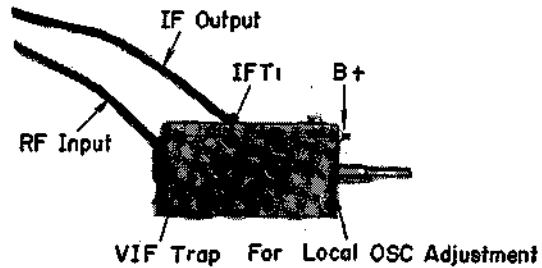

For 5-303T (Fig. 15-2)

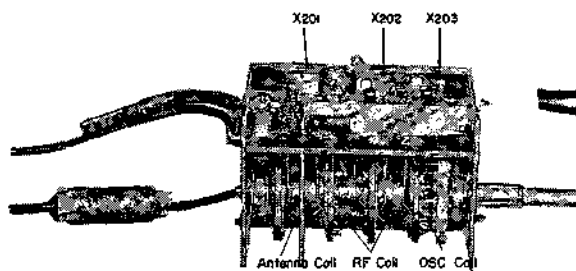

For 5-303E (Fig. 16-1)

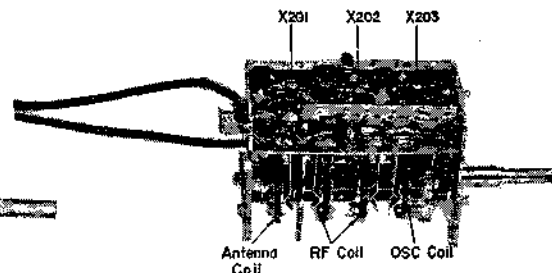

For 5-303T (Fig. 16-2)

### I. The RF Amplifier

The Antenna Impedance is low ( $75\Omega$ ) and the Input Impedance to the RF Transistor is also low. Between the Antenna and the Transistor Input is a tuned circuit of which the resonant impedance is from  $1K$  to  $4K\Omega$ . Taps are used on both sides of the Tuned Circuit for correct impedance matching which is very important. A tap on the Inductance is made on the Antenna side and a tap is made on the Capacitance on the Transistor side for the impedance matching. The RF Transistor output circuit is double tuned with mutual coupling (Double Peaks). This in combination with the single peak of the input circuit gives an essentially flat Bandwidth of  $6Mc$  for this stage. A Base-grounded Circuit is used for the following reasons.

- 1) The difference in gain between the lower frequencies and the higher frequencies is less in the Base-ground Circuit.
- 2) The adjustment of neutralizing capacitance is very critical in the emitter-grounded circuit so that stability is reduced.
- 3) The Base-grounded Circuit with transistor corresponds to the grounded-grid circuit with vacuum tube. The undesirable feed back between the collector and emitter is greatly reduced in this circuit because the base is grounded. This keeps the amplifier stable even at higher frequencies.

A neutralizing capacitor is used in the emitter circuit as shown in Fig. 17 to prevent oscillation due to stray capacitance.  $R_{ch}$  in Fig. 17-1 is used for a choke coil which grounds the neutralizing point for DC while keeping it at an appropriate AC potential.

Basic Circuit for RF Stage

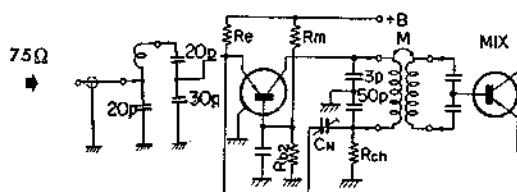

For 5-303E (Fig. 17-1)

Neutralizing Circuit for RF Stage

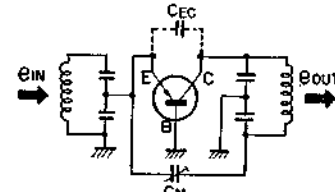

(Fig. 17-3)

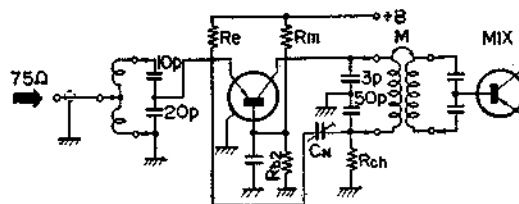

For 5-303T (Fig. 17-2)

A gain of  $14$  dB is possible at  $200Mc$  with a circuit of this type but too much gain tends to make the set unstable and hence the gain has been kept to be about  $10$  dB in our circuit. The gain on the lower channels tends to be higher than that on the higher channels, and so the damping resistors are inserted in the circuit of the lower channels to make the gain difference between the higher and lower channels within  $\pm 1.5$  dB.



## 2. The Mixer Circuit

The Mixer Transistor 2SA161 is emitter-grounded. Impedance matching is made by a capacitance divider in the same way as in the RF Amplifier. The local Oscillator signal is injected into the base of the transistor. The power dissipated in the mixer transistor is very much less (about 1/30~1/50) than the plate loss of the tube mixer. The voltage of the Local Oscillator signal injected is about 0.2 Vrms, which is also much smaller (1/10~1/20) than that in tube mixer. Furthermore, the  $G_m$  of the transistor mixer is high and hence the troubles with mixer noise encountered in tube circuits are of no consequence here in our circuit. This circuit is also neutralized to prevent undesired oscillation.

## 3. The Local Oscillator

The Local Oscillator uses a Colpitts circuit. This circuit is well suited for this use as it does not require a tap on the oscillator coil. The transistor (2SA161) is base-grounded. The thermistor in the base circuit serves to prevent oscillator drift due to temperature changes. The drift is kept within 200 Kc. As mentioned before, each oscillator coil is independent of the others so that the oscillation frequency can be adjusted from outside the tuner by adjusting the screw type cores. The cylindrical Fine Tuning Capacitors are separately shielded to prevent radiation from the set. The adjustable range of the Local Oscillation is approx. 1.5 Mc for Channel 2 (channel A for 5-303T) and approx. 3 Mc for channel 11 (channel H for 5-303T).

## Signal Circuit Board Section

The Signal Circuit Board includes the Video IF, AGC, Sound Amplifier, Video Drive and Synchronizing Pulse Separation circuits. (Fig. 18)

### 1. Video IF Section

- ☆ The Video IF Section consists of four stages with five stagger tuned elements.
- ☆ The Video IF is 26.75 Mc while the Sound IF is 21.25 Mc.
- ☆ The bandwidth of this section is 3.75 Mc. (Fig. 19-1)

### 2. Automatic Gain Control (Fig. 19-2)

The Pulse AGC developed by SONY and the Diode AGC are used together in this set.

The operation of the Pulse AGC Circuit is as follows :

The AGC signal is supplied to the Base of X5 from the Video Detector. The pulse which is generated at the Fly Back Transformer is rectified by D6 and applied to the Collector of X5 so that X5 operates only during the synchronizing period. The AGC signal is amplified by X5 and rectified by D3 and is then applied to the Base of X6 through a Filter Circuit. The Time Constant of this circuit is made very small so that the AGC response is extremely fast, thus permitting operation in moving cars where the signal level may vary with extreme rapidity. Then the AGC current from X6 controls the base bias voltage for X1 and X2, and thus the gain of the Video IF stages. The main features of the Pulse AGC are :

#### 1) Quick response

The AGC action is much faster than in conventional circuits because the Time Constant of the filter circuit is very small (approx. 1/1000 second) compared to that in the conventional one (1/10~1/20 sec). Accordingly, stable reception is achieved even when the input signal level varies at a rate of 1/100 second.

#### 2) Noise free AGC action

The AGC action is hardly influenced by noise since the synchronizing pulses only of the Signal are utilized. On the contrary, in the ordinary peak value AGC system, the AGC voltage varies considerably with the noise content of the video signal.

#### 3) Effective AGC action

The AGC action is quite effective due to higher gain in the AGC loop. Stability against the variation of the temperature and of the power supply voltage is secured also. The AGC Diode D1 (1T22G) connected in parallel with VIFT2 conducts to lower the Q of the IFT2 when the input level exceeds 10 mV.

### Block Diagram of Signal Circuit Board

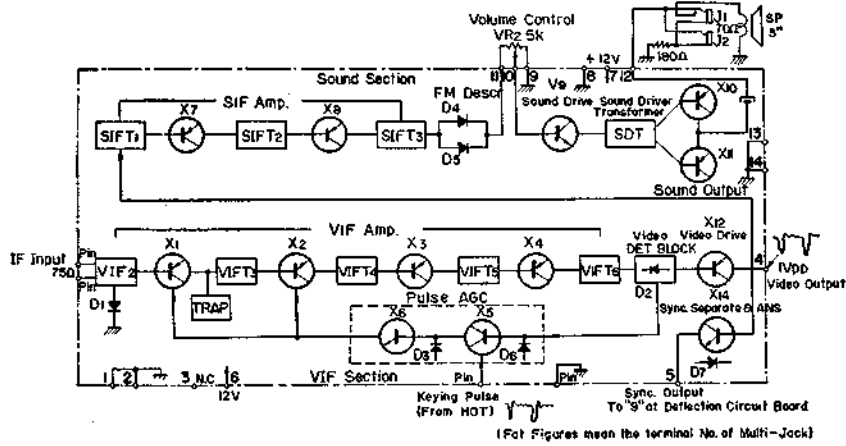

(Fig. 18)

#### VIF Freq. Response

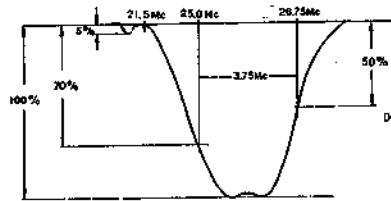

(Fig. 19-1)

#### AGC Characteristics

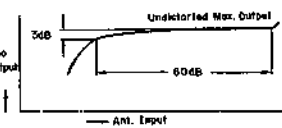

(Fig. 19-2)

### 3. Sound Amplifier Section

The Sound Amplifier Section has two IF stages, a Foster-Seeley Discriminator and two Audio Amplifier Stages. The Output Stage uses the SEPP-OTL (Single Ended Push-pull, No Output Transformer) system. The speaker diameter is 7.5 cm (3") and its impedance is 70Ω. There is a shield plate on SIFT3 to prevent the pulse from the Picture Tube Deflection Yoke to interfere with the sound. The maximum output is 150 mW.

### 4. Video Driver

The Video Driver Circuit is of the Emitter Follower Type (Collector-grounded). The Output Impedance is very

### Signal Circuit Board (Mounted Side)

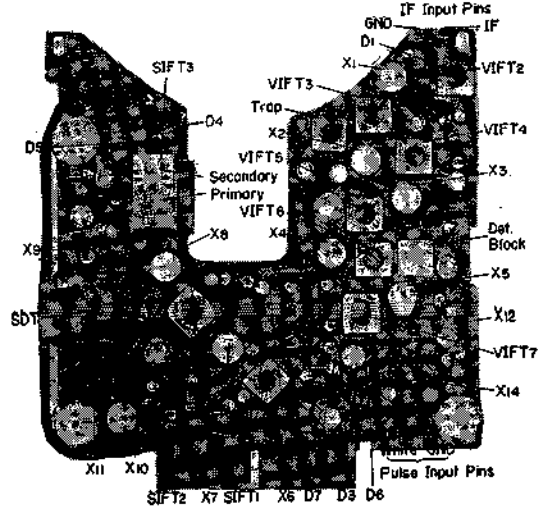

(Fig. 20)

low and this circuit has good frequency characteristics. The Video Signal, Synchronizing Pulse and the Sound are separated at the Emitter of X12 (2SA60).

### 5. Synchronizing Pulse Separation

The synchronizing pulse is separated at X14 which has the Base-grounded and a Bias Current of approximately Zero. The Vertical Synchronizing Pulse is taken from the collector. This stage includes the ANS (Automatic Noise Suppressor) for the synchronizing pulse in which the Diode D7 serves to shortcircuit the pulsing noises of excessive amplitude. This permits stable operation of the set in a car without fear of interference from the ignition sparks and other pulsive noises.

## Deflection Circuit Board and High-Voltage Block Sections

The Deflection Circuit Board contains the Video Output and the Vertical and Horizontal Deflection Circuits.

### 1. Video Output Circuit (See Fig. 21)

A Mesa Type Silicon Transistor (2SC15; X13) is used in the Video Output Circuit. Over 40 Vpp of output is obtained from this circuit. The Picture Tube requires 30 Vpp for sufficient contrast. The Contrast Control is obtained by varying the feedback current by means of the Variable Resistor VR3 which is located in the Emitter Circuit of X13. The gain of the stage can be varied by 16 dB with this control. The Frequency Response is almost flat to 3 Mc by the use of Shunt-peaking (L501-R508) and Series-peaking (L502-R509). Since the Video IF Bandwidth is 3.75 Mc and the beam spot of the Picture Tube is very small, a very sharp picture is obtained. The Horizontal resolution is more than 300 lines and the Vertical, 400 lines. X13 is cut-off during the Blanking Period by the application of pulses from the Horizontal and Vertical Deflection Circuits. The Blanking Pulses are applied to the Emitter of X13.

### Deflection Block

(Fat figures mean the terminal No. of Multi-Jack)

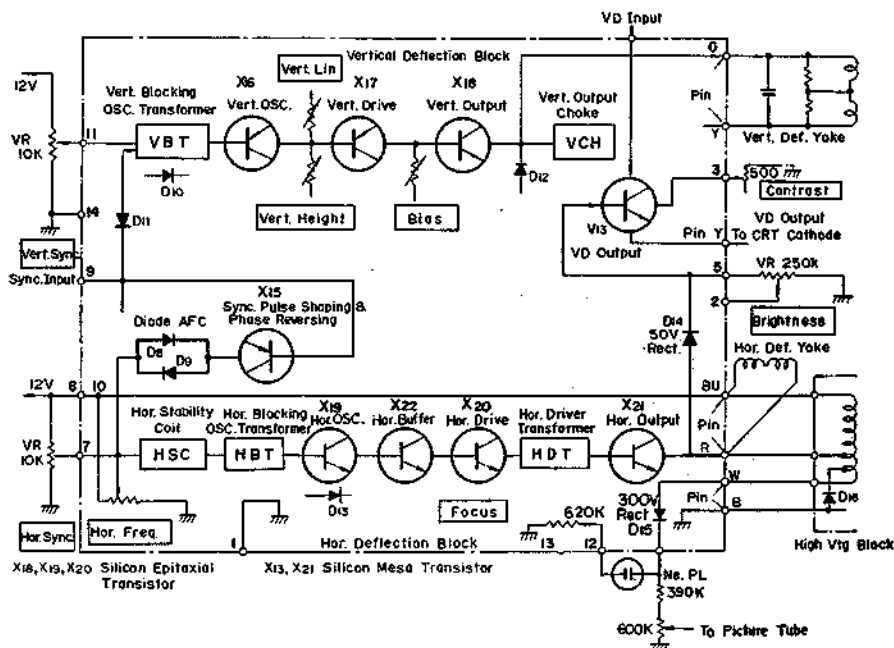

(Fig. 21)

### Deflection Circuit Board (Mounted Side)

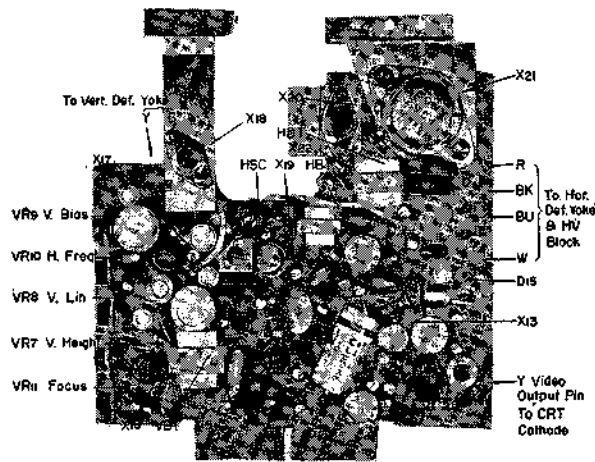

(Fig. 22)

### High Voltage Block

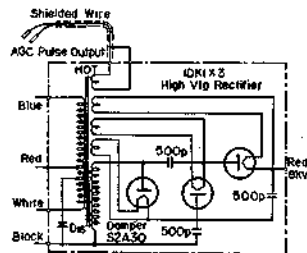

(Fig. 23)

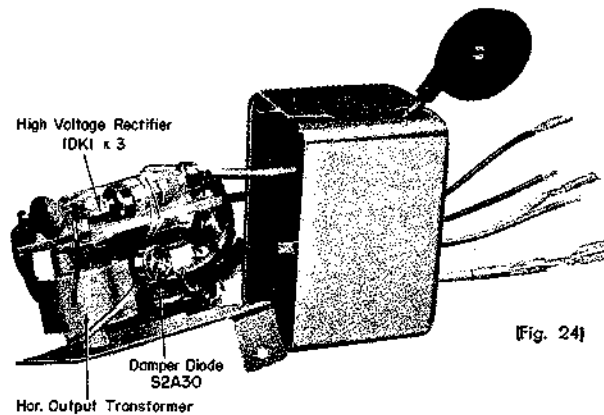

(Fig. 24)

## 2. Vertical Deflection Section (See Fig. 21)

The Vertical Deflection Sawtooth Wave is generated by blocking oscillations in the circuit of X16. It is then amplified by X17 and X18 and applied to the Vertical Deflection Yoke of the Picture Tube. Vertical Amplitude and Linearity are adjusted by Variable Resistors VR7 and VR8 in the Base Circuit of X17. An Epitaxial Transistor X18 (2SC140) is used in the Vertical Deflection Output Circuit. The Epitaxial Transistor is used in this circuit because of the characteristics of being able to withstand the high pulse voltages present in this circuit and because of freedom from temperature effects. The amplitude of the vertical pulses will not decrease with

a rise in temperature. The Vertical Deflection Coil on the Picture Tube is of the Toroidal Type which is more efficient than the conventional type.

**3. Horizontal Deflection Section (See Fig. 21)**

The Horizontal Deflection Pulse is generated by blocking oscillations in the circuit of X19 and is amplified by X22 and X20 which drives X21. X21 in turn generates the Sawtooth Wave which drives the Horizontal Deflection Coil. The Horizontal Output Transistor (X21) is also connected to the Hor. Output Transformer and supplies the input for the High Voltage Circuit with the Flyback Pulse during Cut-Off. All of the Transistors in the Horizontal Deflection Circuit are of the Silicon Type. This assures stable operation almost free from temperature effects.

**4. High Voltage Block**

The High Voltage Block consists of the Horizontal Output Transformer, Damper and the High Voltage Rectifier. All are housed together in one metal case. The Flyback Pulse is stepped up, rectified and the resulting voltages of 8 KV, 300 V and 50 V are applied to the Anode of the Picture Tube, the Second Grid of the Picture Tube and the Video Transistor (X13) respectively. The 8 KV is obtained by means of the three rectifier tubes in voltage tripler circuit.

**5. Focus Adjustment**

The voltage for the Second Grid of the Picture Tube goes also to the Potentiometer VR11 through the Neon pilot Lamp (Ne-PL). The Focusing Voltage is obtained from this Potentiometer and is variable between 0 and 180 V DC.

## Power Supply Section

117 V AC input is converted to 12 V DC by four (4) Selenium Rectifiers in a Bridge Connection as shown in Fig. 26. The Power Transformer is located very near the Picture Tube. Power Transformer with oriented-core is used in this set to prevent any trouble from Flux Leakage.

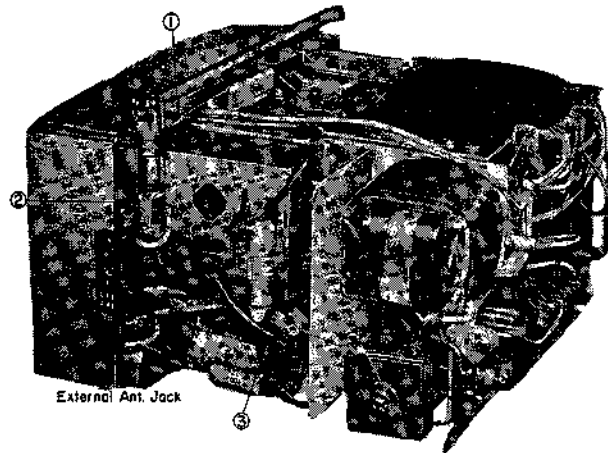

(Fig. 25)

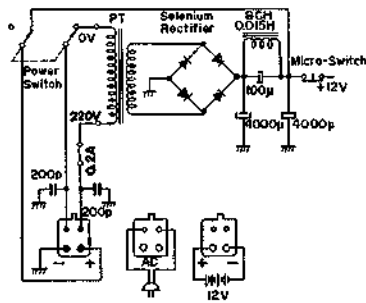

(Fig. 26)

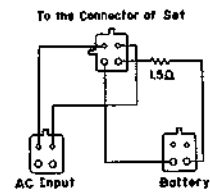

(Fig. 27)

## Method of Disassembling the Set

### To Remove the Front Control Panel:

1. Pull all Control Knobs straight out. The Fine Tuning Knob may be somewhat difficult to remove—use force.
2. Remove the two small screws on the Front Control Panel. The Front Control Panel can now be removed.

(Fig. 28)

### To Remove the Back Cabinet Cover:

Remove screw ① (located on the top) and ② (located on the left side). Remove screws ③, ④, ⑤ and ⑥ on the back. The Back Cover can now be removed by pulling straight back. (Fig. 29)

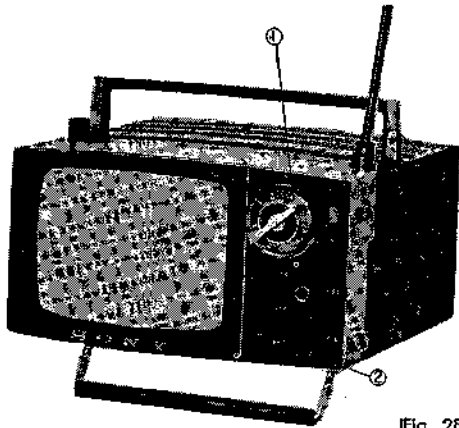

(Fig. 28)

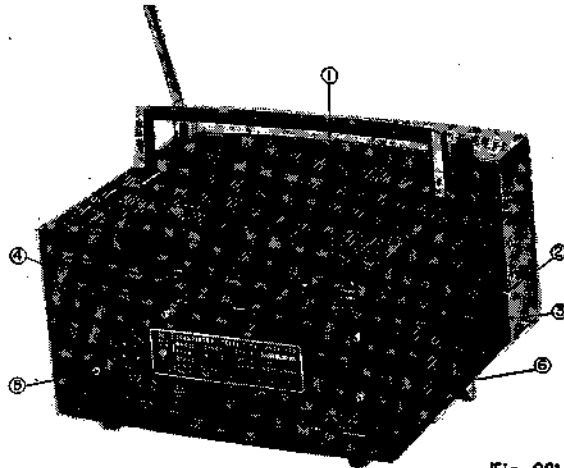

(Fig. 29)

### To Remove the Telescopic Antenna and the Tuner:

1. Pull off the Pin Connectors of the Tuner IF Lead Wire and the shielded Ground Wire from the Terminals on the Signal Circuit Board as shown in Fig. 30.
2. Remove screws ①, ② and ③. ③ holds the back of the Tuner. (Fig. 30)
3. Push the Telescopic Antenna and the External Antenna Connectors in the direction shown by the Arrows in Fig. 30. The Telescopic Antenna and the Connectors can now be detached.

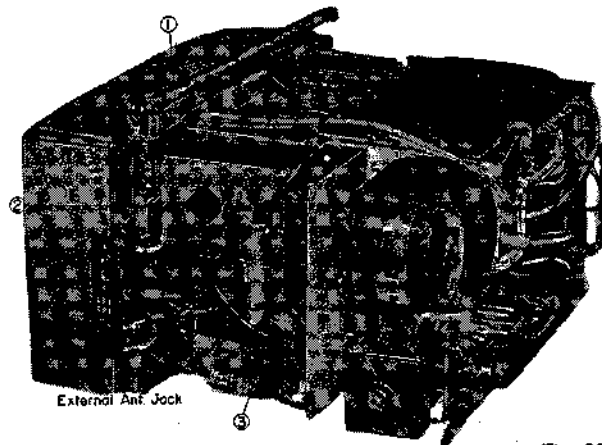

(Fig. 30)

- The Tuner can be detached by removing two screws on the Front located near the Tuning Control Shaft. One screw is on the Front Panel and the other is inside on the Tuner as shown in Fig. 31.

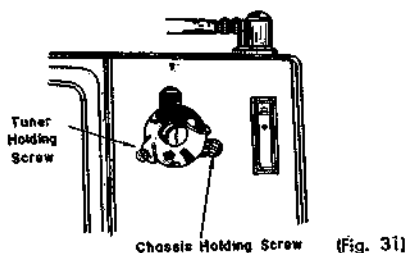

- The Tuner, Telescopic Antenna and Antenna Connectors can be removed from the set by unsoldering the Red Wire to the Front of the Tuner, the Black Wire to the Chassis and the Yellow Wire with the Resistor to the Antenna Jack. The IF Lead Wire to the Tuner with the Pin Connectors can be pulled through from the back of the Picture Tube. (Fig. 32~33)

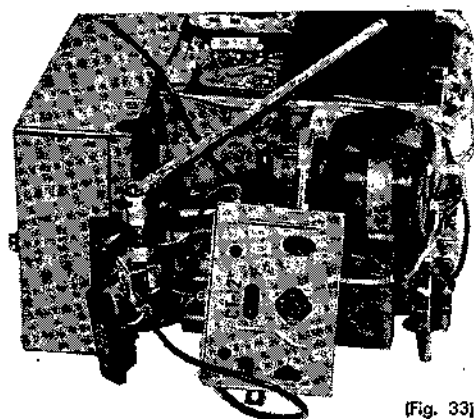
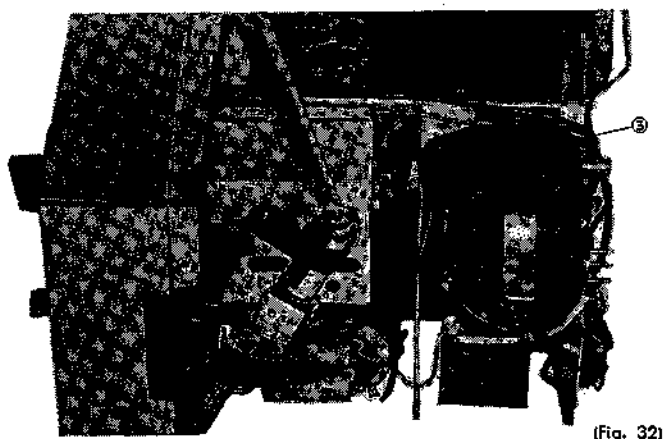

**To Remove the Signal Circuit Board :**

Remove Screws ① and ②. Slightly loosen the Screw ③ holding the Connector Socket on the back of the Chassis (Fig. 34). Pull out the two Connectors from the Pins on the back side of the Signal Circuit Board. The Block can be removed as a unit by pulling directly away from the Connector Socket.

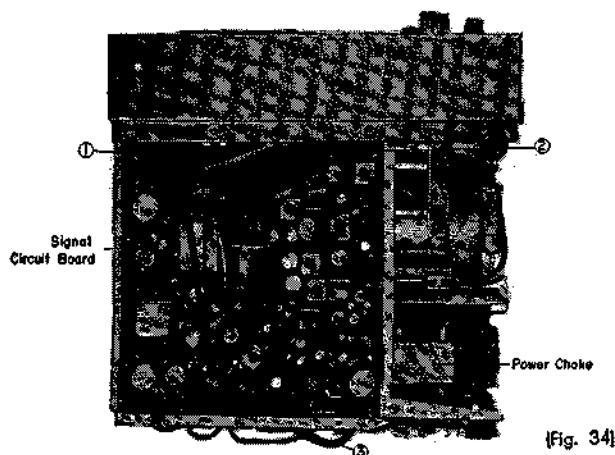



**To Remove the Deflection Circuit Board :**

1. Remove Screws ①, ② and ③. (Fig. 35)

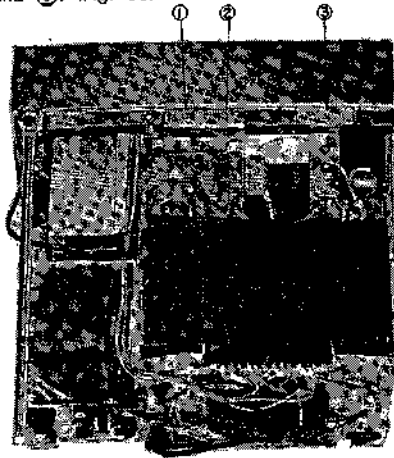

(Fig. 35)

2. Pull out the connectors shown in Fig. 36 & Fig. 37.

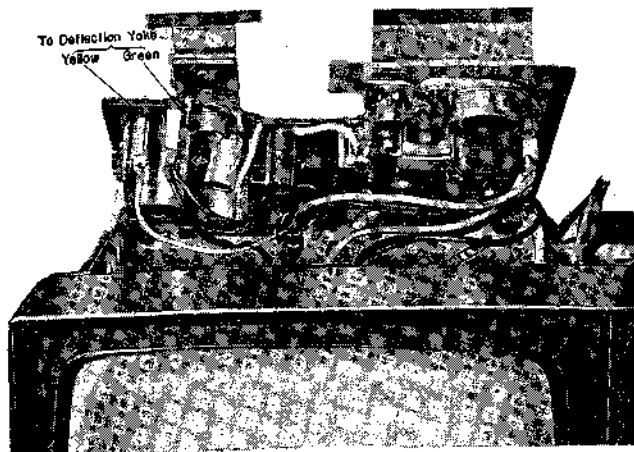

(Fig. 36)

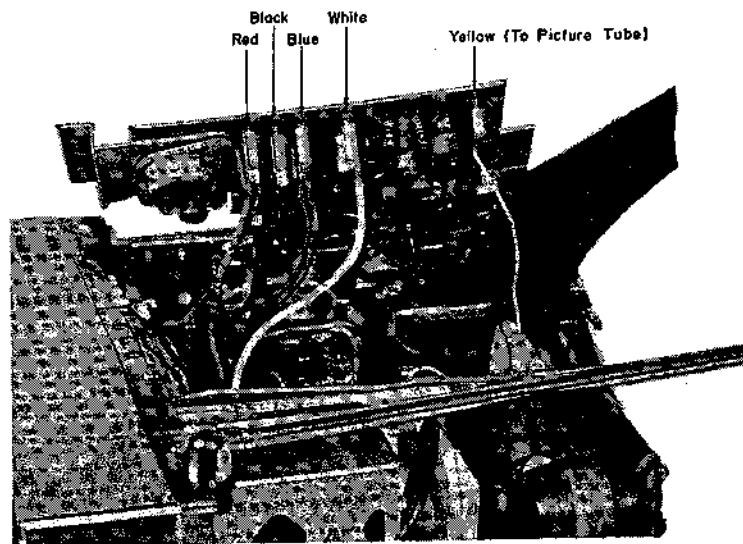

(Fig. 37)

Note: SONY Extension Cable and Circuit Connector are available to make service on the Circuit Boards more convenient. (Fig. 38 & Fig. 39)

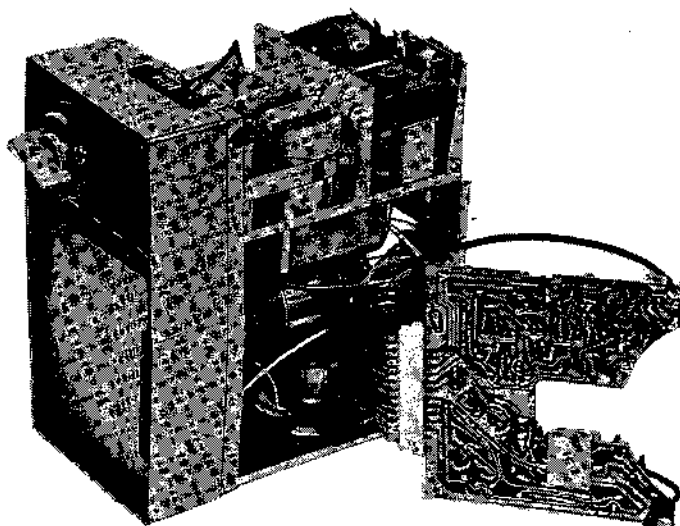

(Fig. 38)

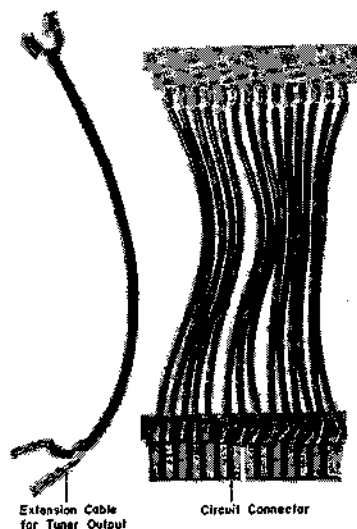

(Fig. 39)

**To Remove the Chassis from the Front Panel: (Fig. 40)**

Remove Screws (2), (3) and (4). Remove the Screw (1) from the front side after pulling off the Channel Selector Knob and the Fine Tuning Knob (Refer to Fig. 4 on page 3)

Unsolder the Red, Blue and Black Wires from the Pin Connectors. These wires go to the Picture Tube Yoke. Also unsolder the Green Wire from the Choke Coil located just below the Speaker. Pull off the High Voltage Anode Connector from the side of the Picture Tube. This is a Snap Fastener but use caution in removing it. Pull off the Socket of the Picture Tube straight back.

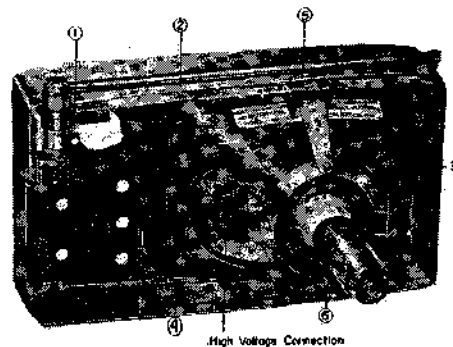

(Fig. 40)

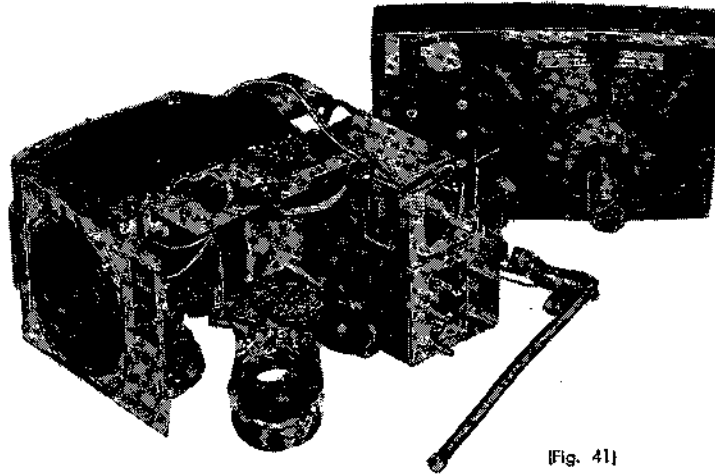

[Fig. 41]

**To Remove the Picture Tube :**

Remove the Screws and Nuts ⑤ and ⑥ shown in Fig. 40 and lift up the Picture Tube.

**To Remove the High Voltage Block :**

1. Unsolder three lead wires (Red, Blue & Black).
2. Pull off the Anode Cap
3. Pull off the Pulse Supplying Pin Connectors coming from the Signal Circuit Board.
4. Remove the Phillips Screw

NOTE : It is not recommended that the High Voltage Block be disassembled because a special Insulating Material is used inside to coat all High Voltage Points.

## Trouble Shooting

### by Replacement of the Defective Block

Provisions have been made in this Micro TV for easy servicing. The main part of the set is made of the four blocks of the Tuner, the Signal Circuit Board, the Deflection Circuit Board, and the High Voltage Block. Each of these blocks has complete interchangeability and hence the servicing can be performed by simply replacing the defective Block with a new one.

The ways of judging which Block is defective and the method of replacing the Blocks will be given below. In servicing according to this method, the following tools and parts are needed.

**Replacement Blocks :** (See Fig. 42)

Tuner, Signal Circuit Board, Deflection Circuit Board, and High Voltage Block

#### Tools and Meters :

Circuit-tester, of internal resistance around  $20\text{ K}\Omega/\text{V}$  Cord with Clips.....2 pieces

Electrolytic Condenser,  $3\mu\text{F}$ , 50 V or more.....1 piece

Resistor, around  $15\text{ K}\Omega$ .....1 piece

#### Screw Drivers

For 3 mm Screws, Phillips and ordinary

For 2.6 mm Screws, Phillips and ordinary

No. 3 for watches (for adjustment of focal oscillator)

Tweezers

Soldering Iron

#### Raster

##### 1. No Raster and No Sound

Suspectable Item : ☆ Power Supply

Check the power supply. If there is no trouble in the power supply, there must be two or more Blocks defective. Then, proceed with the checking according to the following.

##### 2. No Raster

See first whether the Neon Lamp is lit.

##### 1) The Neon Lamp is OFF.

Suspectable Items : ☆ Deflection Circuit Board

☆ High Voltage Block

a) Replace the Deflection Circuit Board.

b) If the Neon Lamp is not lit after (a), replace the High Voltage Block.

##### 2) The Neon Lamp is lit.

Suspectable Items : ☆ High Voltage Block

☆ The Picture Tube

☆ The Brightness Control Circuit

a) See whether the filament of the Picture Tube is ON. If the filament is OFF, check the socket of the Picture Tube. The pins for the filament are Nos. 3 and 4.

b) If the filament is ON, the trouble is probably with the High Voltage Block. Before proceeding on to replace the High Voltage Block, see whether the cathode circuit of the Picture Tube (the Brightness Control Circuit) is all right.

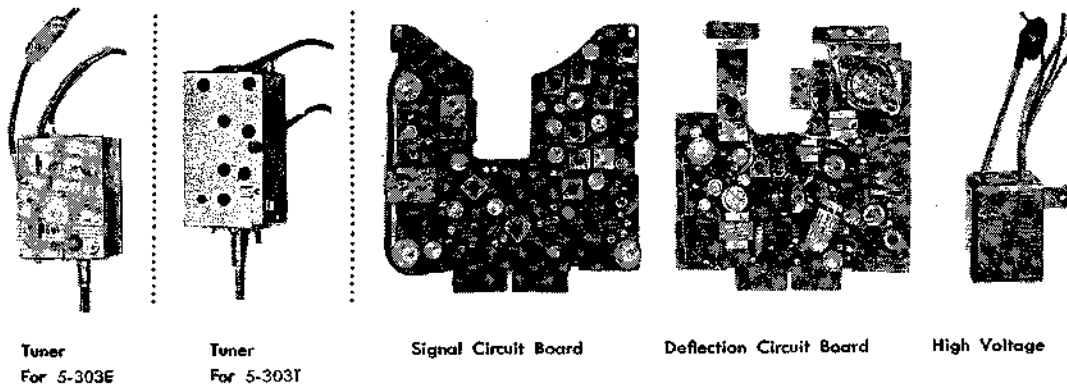

(Fig. 42)

Circuit Diagram for Video Amp. (Fat Figures mean the terminal No. of Multi-Jack)

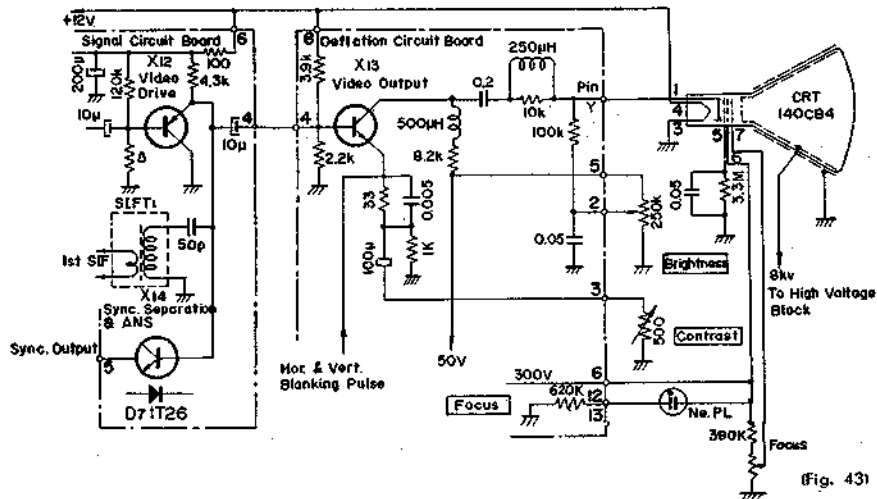

To do this, measure the cathode voltage from the copper-clad side of the Deflection Circuit Board. (Refer to Fig. 43) If this voltage is varied between 0 and 40 to 50 volts by an adjustment of the Brightness Control, the cathode circuit is all right, and the High Voltage Block is to be replaced.

If this voltage is abnormal, the Brightness Control Circuit on the Deflection Circuit Board must be checked.

- c) If the raster still does not appear after replacing the High Voltage Block, the Picture Tube may be defective.

**CAUTION**

**NEVER ATTEMPT TO CHECK THE HIGH VOLTAGE (8 KV) CIRCUIT BY SPARK TEST**

The high voltage is often tested by a Spark Test. But, in Transistor TV this is likely to cause damage not only to the Horizontal Deflection Circuits but also to other seemingly not related parts of the set. Especially, the High Voltage spark will adversely affect the transistors on the Signal Circuit Board because of the Pulse AGC circuit employed.

- 3. Raster appears but is abnormal.

First of all, check the 12 V DC Power Supply.

- 1) Too small Raster

Suspectable Item : ☆ Deflection Circuit Board

### Replace the Deflection Circuit Board

#### 2) Raster is dark.

Suspectable Items :       ☆ Picture Tube  
                                  ☆ High Voltage Block

- a) When the Raster Size is normal but is not bright enough, the trouble is almost certainly with the Picture Tube.
- b) When the Raster spreads out and gets dark while the brightness is meant to be increased, the trouble is with the reduced emission of the High Voltage Rectifier Tube and the High Voltage Block must be replaced.

#### 3) The left side of the Raster is elongated and gets dark.

Suspectable Item :       ☆ High Voltage Block

This is an indication of broken Damper Diode, and hence the High Voltage Block must be replaced.

### Video Output and Synchronization

#### 1. No Picture (Sound is normal)

Suspectable Items :       ☆ Deflection Circuit Board  
                                  ☆ Signal Circuit Board

Since the Video Output Circuit of this set is on the Deflection Circuit Board, check the Video Output Circuit as follows :

Apply AC test voltage taken from the secondary winding of the transformer through a 15 K $\Omega$  Resistor and a 3 $\mu$ F, 50 WV or more, Electrolytic Capacitor, to the Terminal No. 4 (The input terminal to the Video Output Circuit) of the Deflection Circuit Board as shown in Fig. 44. If the AC hum appears on the Picture Tube, replace the Signal Circuit Board. If not, replace the Deflection Circuit Board.

#### 2. Failure of Synchronization

##### 1) Failure of both Horizontal and Vertical Synchronization

Suspectable Items :       ☆ Deflection Circuit Board  
                                  ☆ Signal Circuit Board

Measure the voltage at Terminal No. 5 of the Signal Circuit Board and decide whether the trouble is with the Signal Circuit Board or with the Deflection Circuit Board. The normal value of the voltage is around 10.5 V. (Fig. 44)

If the voltage is more than 10.5 V, replace the Signal Circuit Board.

If it is abnormally low, replace the Deflection Circuit Board.

##### 2) Failure of either Horizontal or Vertical Synchronization alone

Suspectable Item :       ☆ Deflection Circuit Board

In this case replace the Deflection Circuit Board.

#### 3. No Picture and No Sound

Suspectable Items :       ☆ Tuner  
                                  ☆ Signal Circuit Board

a) Replace the Signal Circuit Board and see the result.

b) Apply the output from another tuner to the Input Terminal of the Signal Circuit Board as shown in Fig. 45, and see the result. The power to this Tuner is to be taken from the set with a length of cord with clips.

4. Only one or a few Channels are defective

Suspectable Item : ☆ Tuner

If the Antenna System and the Fine Tunings are all right, the trouble is with the Tuner. This can be checked by use of another Tuner as mentioned in 3 (b).

5. Other Troubles

- Suspectable Items :
- ☆ Tuner
  - ☆ Signal Circuit Board.
  - ☆ Deflection Circuit Board

For troubles like low contrast, poor signal-to-noise ratio and poor resolution, replace the Signal Circuit Board first. Then, if the signal-to-noise ratio is still poor, replace the Tuner. If the contrast is low, replace the Deflection Circuit Board.

To Check Video Amp. & Synchronization Circuit

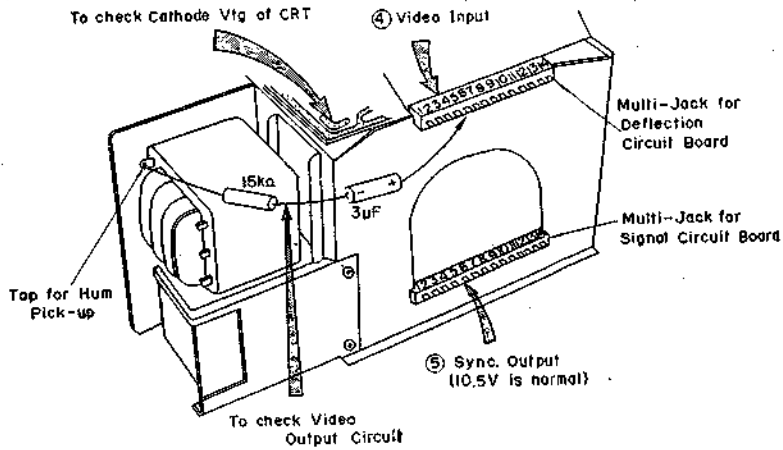

(Fig. 44)

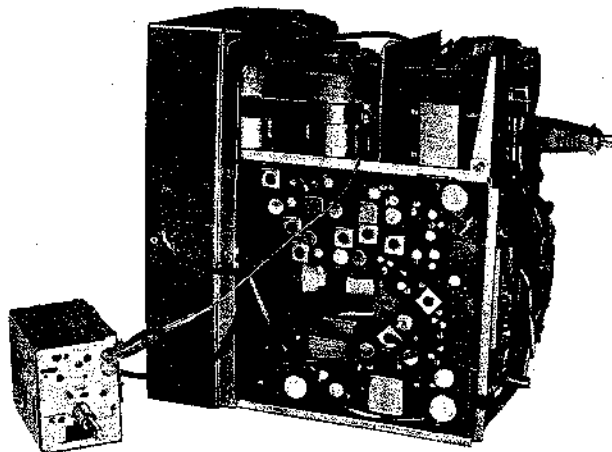

(Fig. 45)

**Sound (Picture is normal)**

1. No Sound

Suspectable Items :           ☆ Speaker  
  ☆ Signal Circuit Board

Listen with the earphone.

- a) Check the Speaker and the Earphone Jack if sound is heard through the earphone
- b) If still no sound can be heard replace the Signal Circuit Board.

2. Sound is distorted.

Suspectable Items :           ☆ Speaker  
  ☆ Signal Circuit Board

Judge by hearing the sound whether the trouble is with the defective Speaker. If the trouble is not caused by the Speaker, replace the Signal Circuit Board.

3. Buzzing

Suspectable Items :           ☆ Antenna  
  ☆ Fine Tuning  
  ☆ SIFT3  
  ☆ Signal Circuit Board

- a) If the Buzz appears only on some specific channel, the trouble is not with the set itself. Adjust the Antenna and the Fine Tuning.
- b) If the Buzz appears on all channels, adjust the blue core of SIFT3.
- c) Then, if the Buzz still exists, replace the Signal Circuit Board.

4. Other troubles with Sound

Suspectable Item :           ☆ Signal Circuit Board

For other troubles with the sound, replace the Signal Circuit Board.

**Sony Corporation**

© 1965

— 24 —

9-962-063-01

78B0403-6  
Printed in Japan



# SONY®

## SUPPLEMENT TO SERVICING GUIDE

# MICRO TV 5-303E

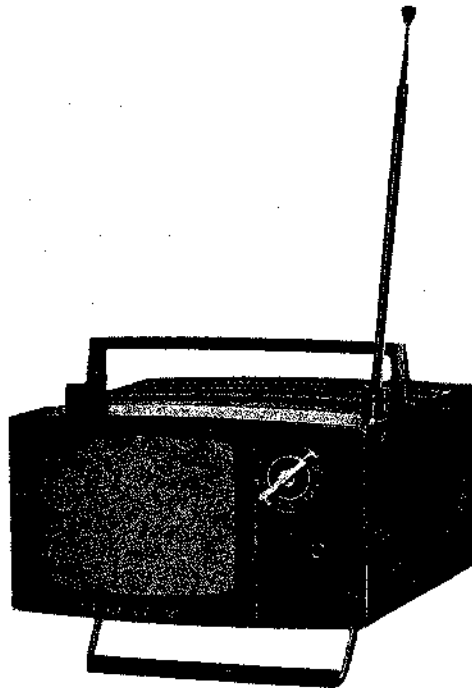

---

### CONTENTS

	Page
Mounting Diagram	
Signal Block .....	2
Deflection Block .....	3
Schematic Diagram .....	5, 6
Voltage Distribution Chart	
Tuner .....	4
VIF AMP Circuit .....	4
Sound Circuit .....	7
SYNC SPLIT Circuit .....	7
SYNC SEP, AMP & NOISE LIMIT Circuit .....	7
VERT Deflection Circuit .....	8
Video Output Circuit .....	8
HOR DEF Circuit .....	9
Electrical Parts List (A) .....	10, 11, 12
Electrical Parts List (B) .....	12, 13
Mechanical Parts List .....	13, 14

# Mounting Diagram

— Signal Block —

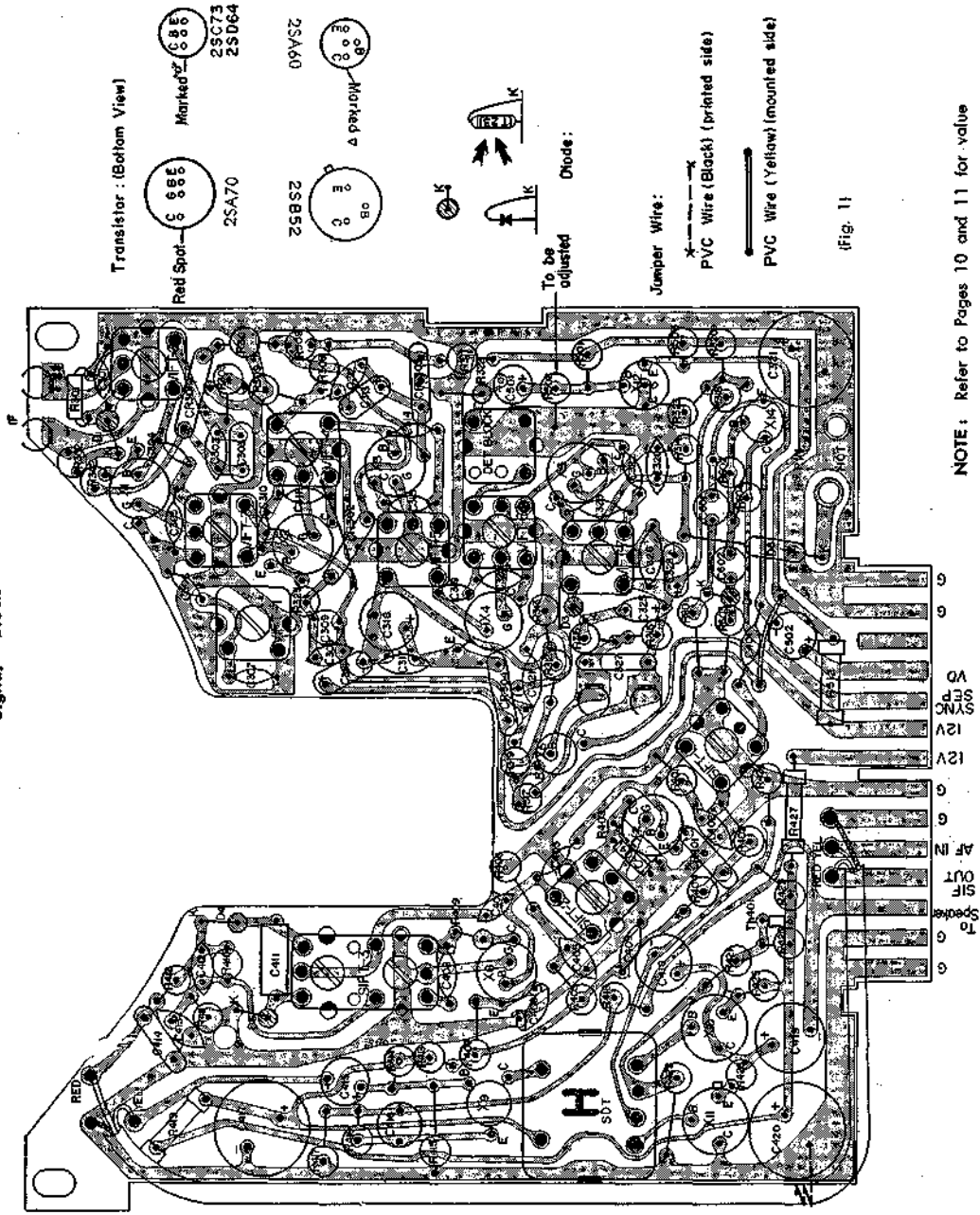

NOTE: Refer to Pages 10 and 11 for value of the circuit constants.

Mounting Diagram  
— Deflection Block —

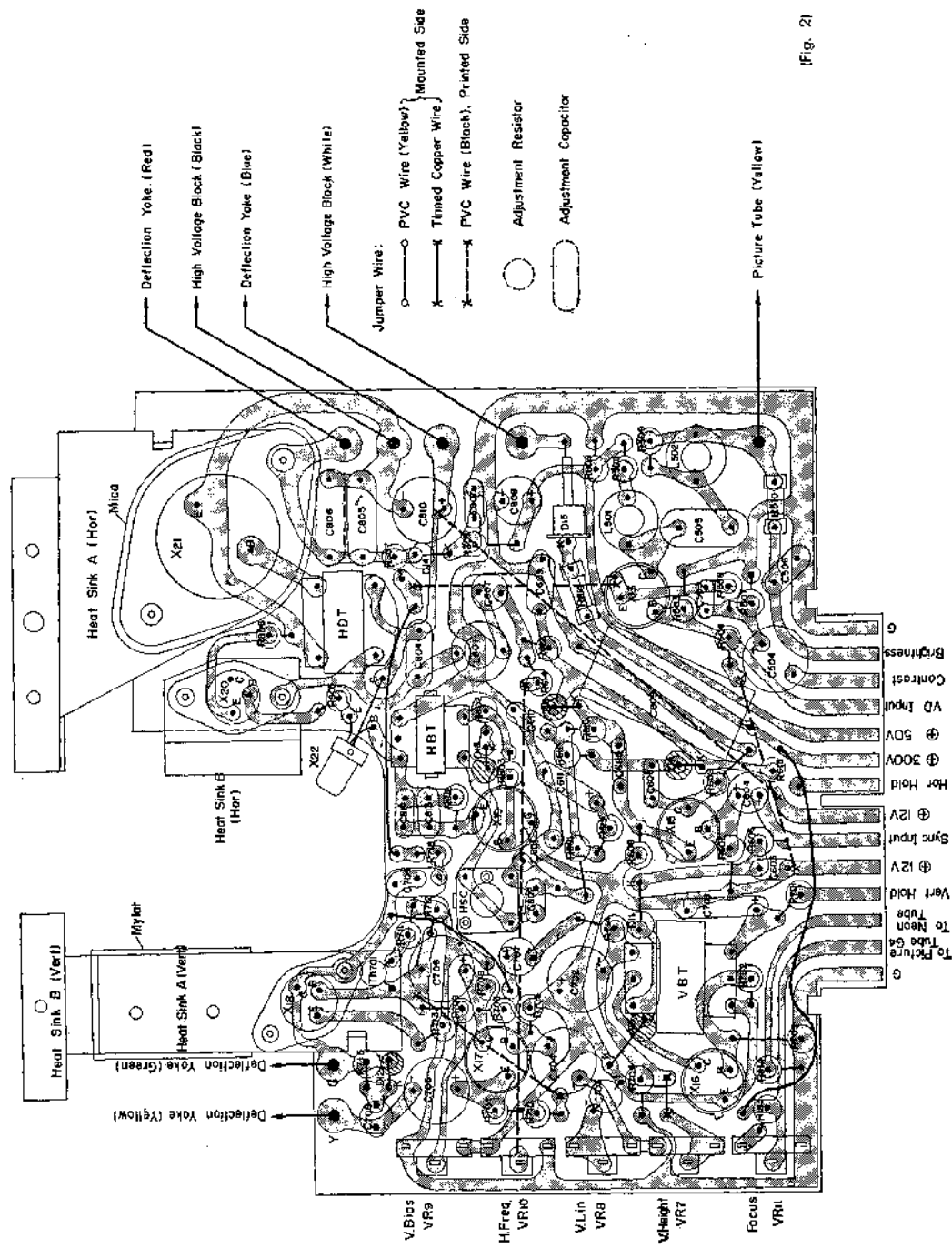

(Fig. 2)

Voltage Distribution Chart  
— Tuner —

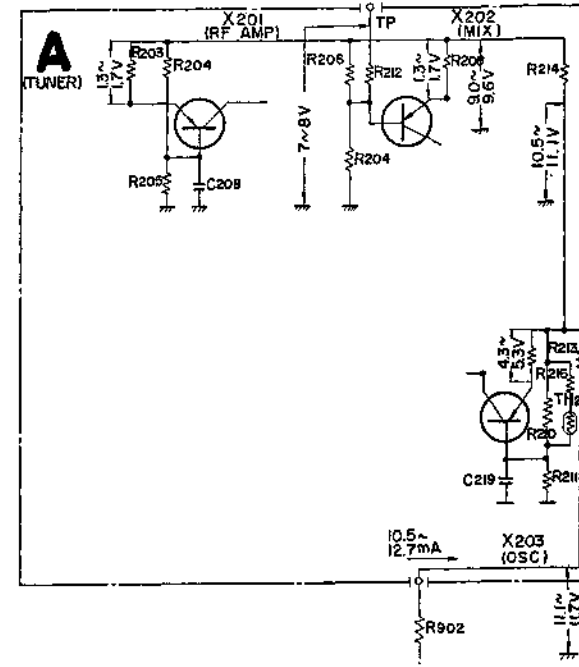

(Fig. 3)

Voltage Distribution Chart  
— VIF AMP Circuit —

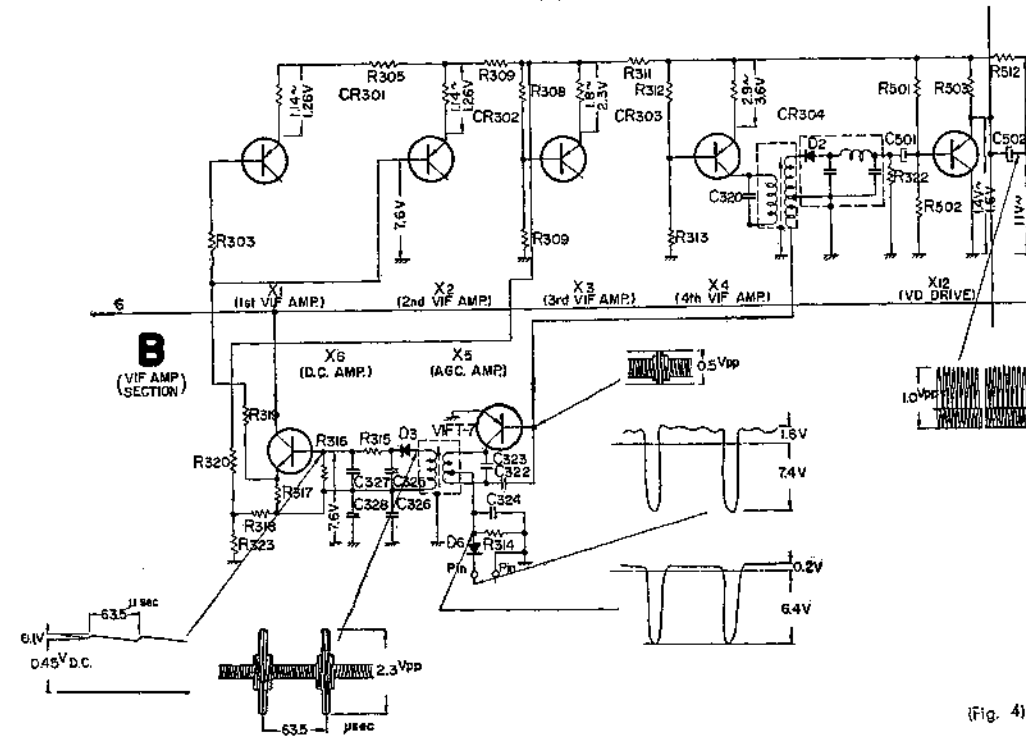

(Fig. 4)

# Schematic Diagram for TV 5-303E

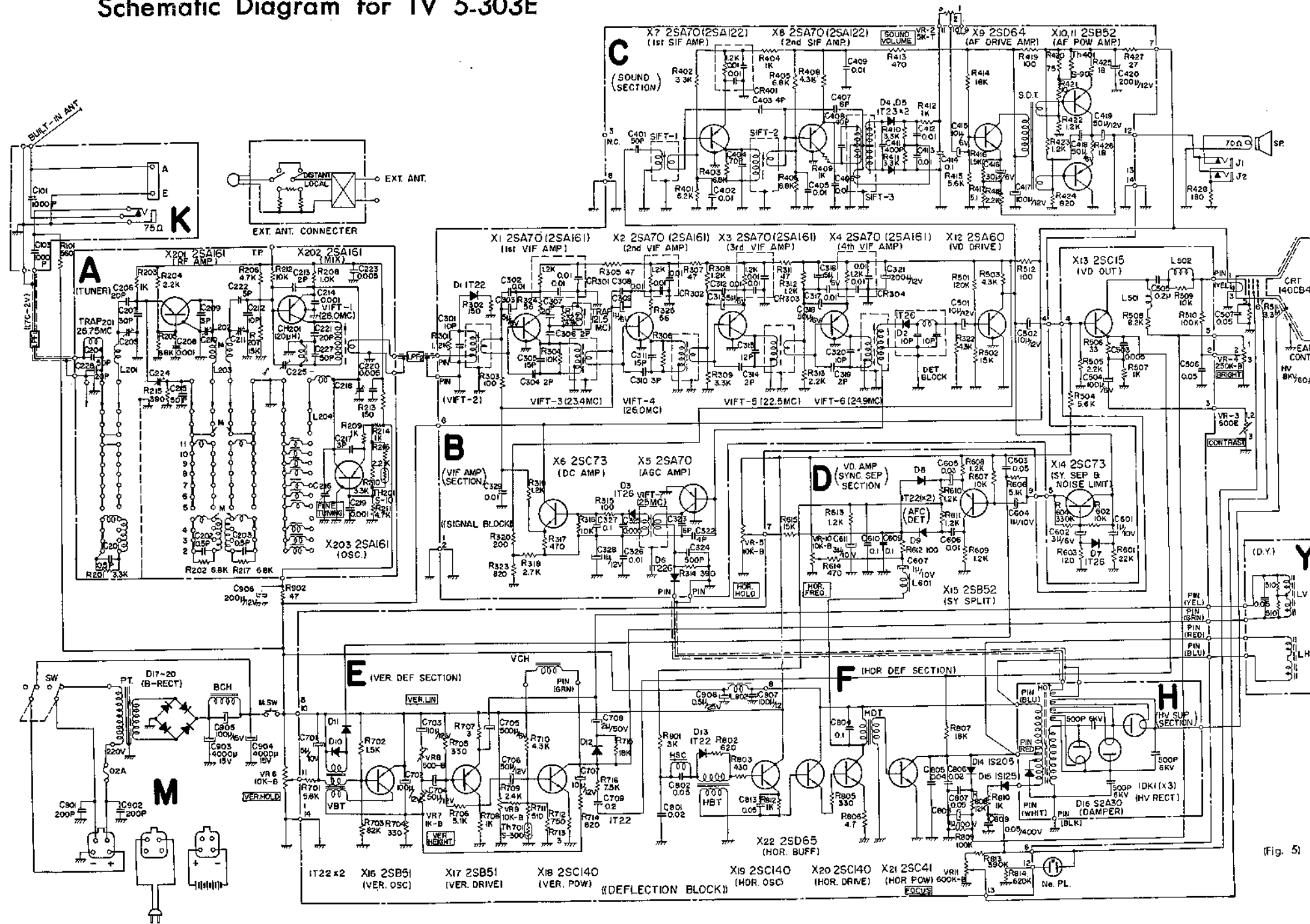

(Fig. 5)

- △ To be adjusted and value may differ from that indicated.
- ※ Used in some set for adjustment purpose.

NOTE: Refer to pages 10 and 11 for value of the circuit constants.

**Voltage Distribution Chart**

— Sound Circuit —

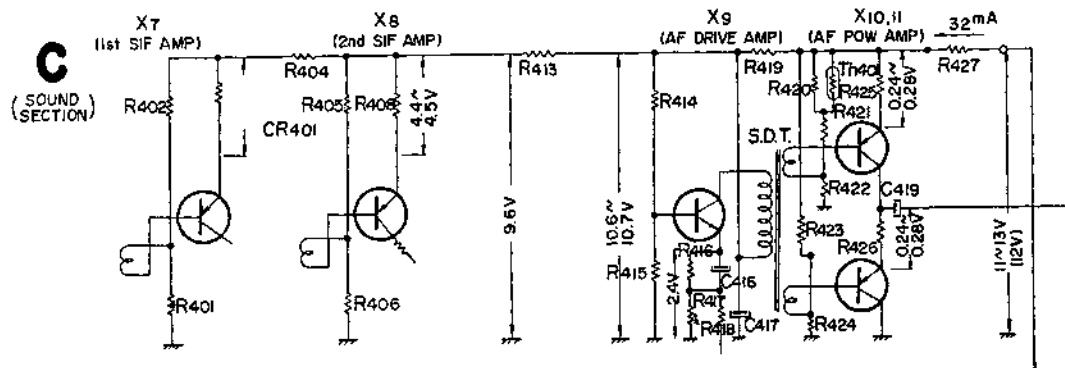

(Fig. 6)

**Voltage Distribution Chart**

— SYNC SPLIT Circuit —

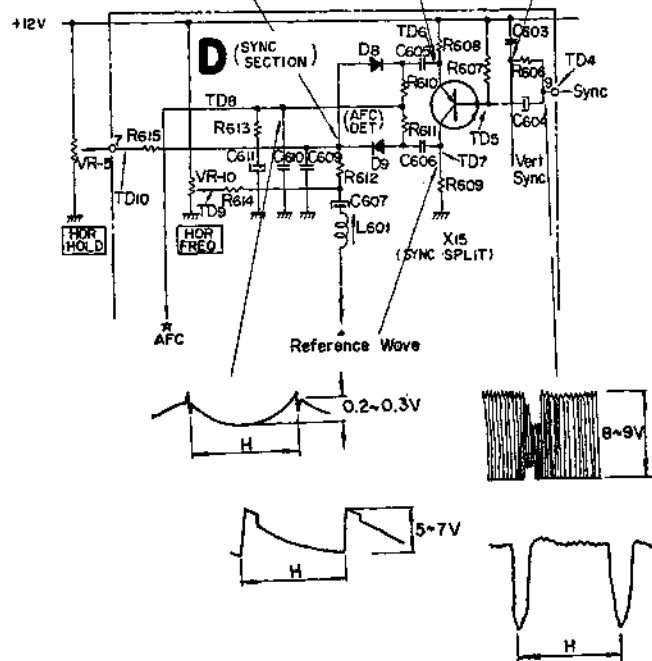
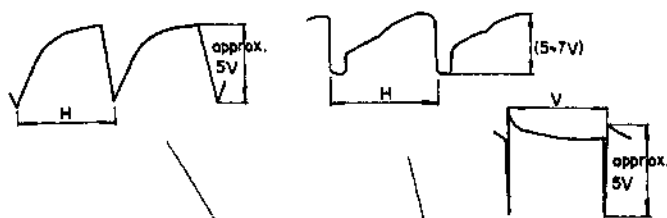

DC Voltage: TD<sub>4</sub>...10V, TD<sub>5</sub>...11.5V, TD<sub>6</sub>...10.5V, TD<sub>7</sub>...1.5V  
 TD<sub>8</sub>...5V, TD<sub>9</sub>...6.5V, TD<sub>10</sub>...5.5V

(Fig. 7)

**Voltage Distribution Chart**

— SYNC SEP, AMP & NOISE LIMIT Circuit —

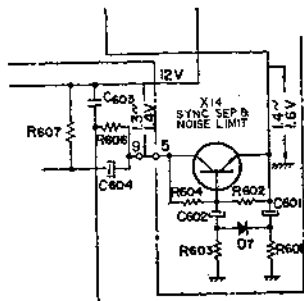

(Fig. 8)

**Voltage Distribution Chart**

— VERT Deflection Circuit —

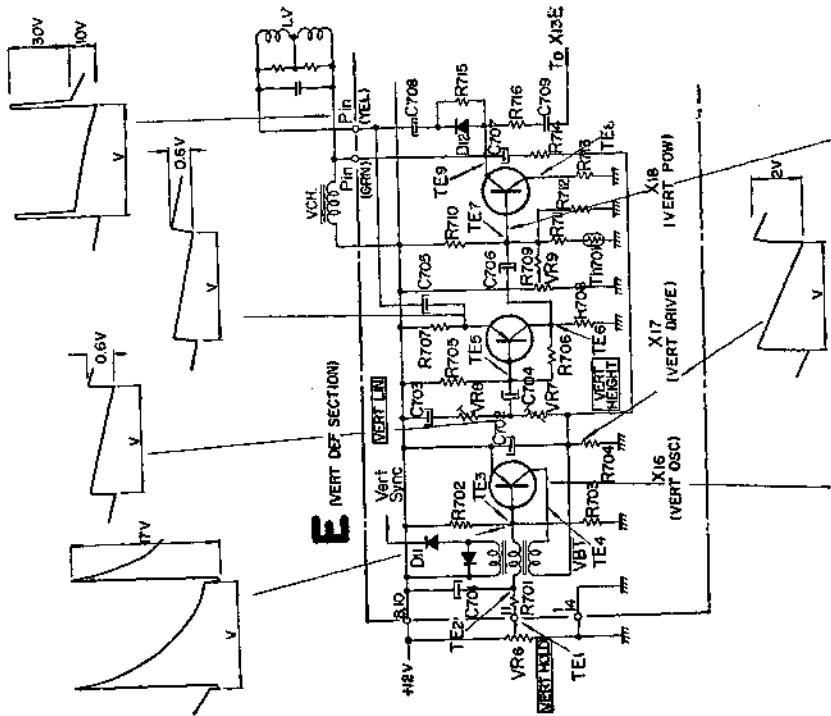

(Fig. 9)

DC Voltage: TE<sub>1</sub>...6-9V, TE<sub>2</sub>...16V, TE<sub>3</sub>...16V, TE<sub>4</sub>...5.5V, TE<sub>5</sub>...11.7V,  
 TE<sub>6</sub>...8.0V, TE<sub>7</sub>...1.0V, TE<sub>8</sub>...0.33V, TE<sub>9</sub>...9.5V

**Voltage Distribution Chart**

— Video Output Circuit —

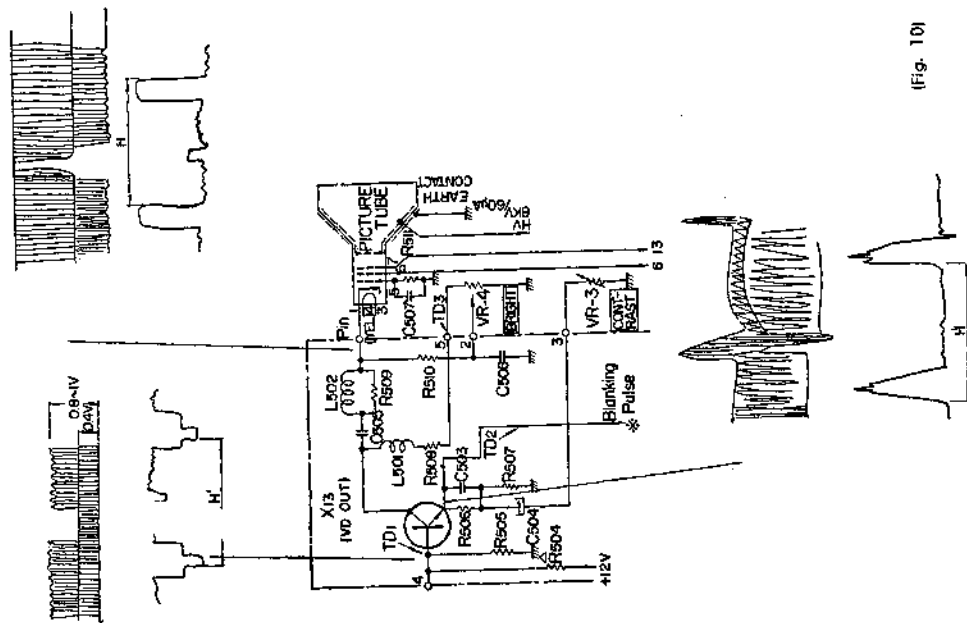

(Fig. 10)

DC Voltage: TD<sub>1</sub>...3.2V, TD<sub>2</sub>...2.6V, TD<sub>3</sub>...50V

### Voltage Distribution Chart

— HOR DEF Circuit —

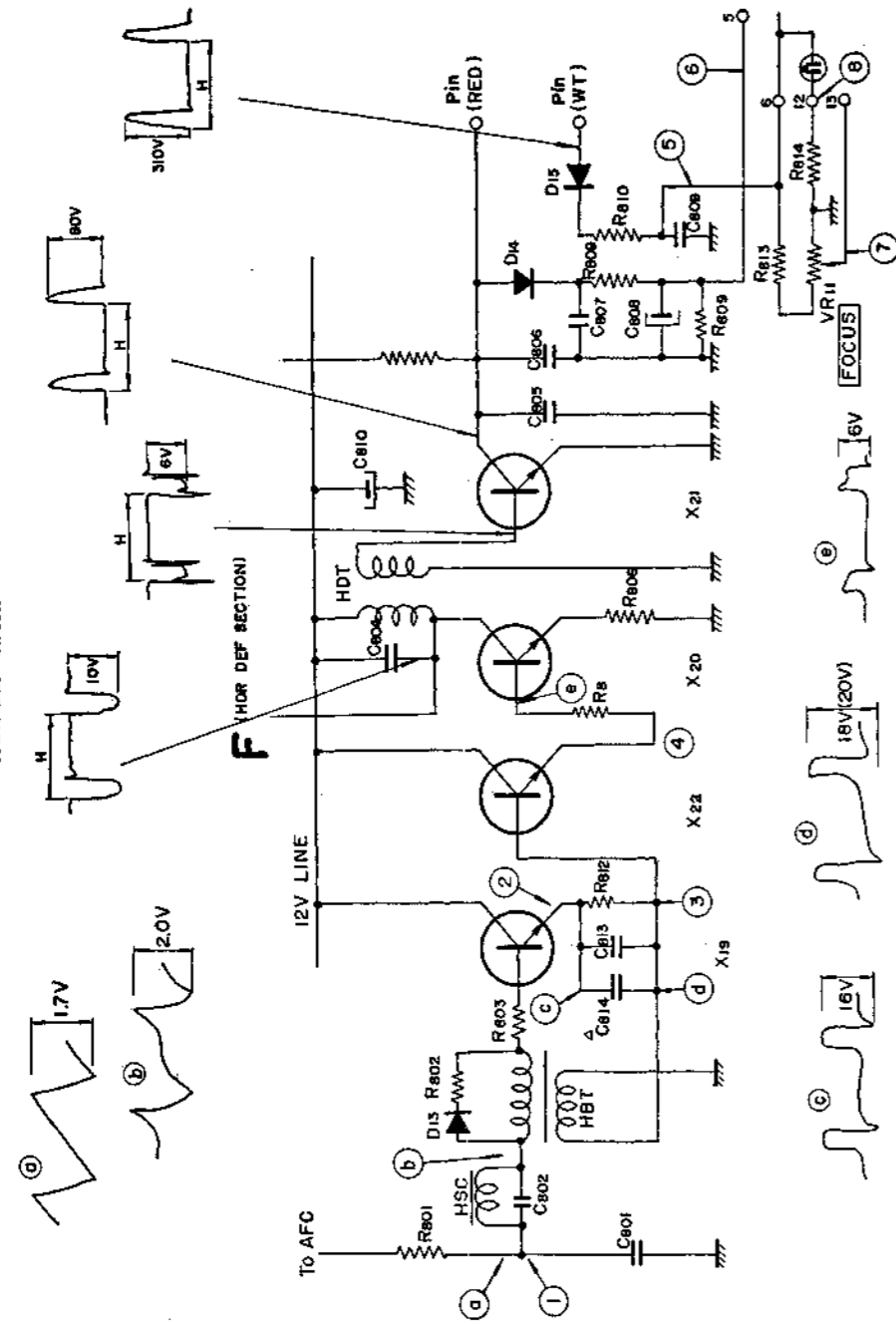

(Fig. 11)

REMARKS FOR THE ELECTRICAL PARTS LIST ON PAGE 10 & 11.

Parts No. of Resistor

- 1-201- Composition Resistor
- 1-203- Carbon Resistor
- 1-207- Wire Wound Resistor

DC Voltage : ①...2.1V, ②...2.7V, ③...0.02V, ④...1.7V, ⑤...290V, ⑥...50V, ⑦...50~100V, ⑧...230V

### Electrical Parts List (A) for TV 5-303E

(Refer to the REMARKS on page 9)

Part No.	Symbol	Description	Part No.	Symbol	Description
1-221-276-11	VR <sub>2</sub>	Potentiometer	1-201-133-00	R <sub>400</sub>	1 KΩ RC1/8L
-275-11	VR <sub>3</sub>	Volume Control 5 KΩ-T	1-203-373-00	R <sub>410</sub>	3.3 KΩ RD1/8L
-265-11	VR <sub>4</sub>	Contrast Control 500Ω-E	-373-00	R <sub>411</sub>	3.3 KΩ "
-297-11	VR <sub>5</sub>	Brightness Control 250 KΩ-B	-367-00	R <sub>412</sub>	1 KΩ "
-297-11	VR <sub>6</sub>	Horizontal Hold Control 10 KΩ-B	-361-00	R <sub>413</sub>	470Ω "
-335-00	VR <sub>7</sub>	Vertical Hold Control 10 KΩ-B	-385-00	R <sub>414</sub>	18 KΩ "
-326-00	VR <sub>8</sub>	Vertical Height Control 1 KΩ-B	-378-00	R <sub>415</sub>	5.6 KΩ "
-327-00	VR <sub>9</sub>	Vertical Linearity Control 500Ω-B	-405-00	R <sub>416</sub>	1.5 KΩ "
-327-00	VR <sub>10</sub>	Vertical Bias Control 10 KΩ-B	-351-00	R <sub>417</sub>	5.1 KΩ "
-327-00	VR <sub>10</sub>	Horizontal Frequency Control 10 KΩ-B	-370-00	R <sub>418</sub>	2.2 KΩ "
1-221-351-00	VR <sub>11</sub>	Focus Control 600 KΩ-B	-011-00	R <sub>419</sub>	100Ω RD1/4L
1-101-406-01	CR <sub>301</sub>	Encapsulated Component	-356-00	R <sub>420</sub>	75Ω RD1/8RL
-406-01	CR <sub>302</sub>	1.2 KΩ, 0.01 μf, 0.01 μf	-315-00	R <sub>421</sub>	10Ω "
-406-01	CR <sub>303</sub>	"	-368-00	R <sub>422</sub>	1.2 KΩ RD1/8RL
-406-01	CR <sub>304</sub>	"	-368-00	R <sub>423</sub>	1.2 KΩ "
-406-01	CR <sub>401</sub>	"	-366-00	R <sub>424</sub>	820Ω "
1-201-454-11	R <sub>101</sub>	Resistor	-308-00	R <sub>425</sub>	18Ω "
1-203-095-00	R <sub>102</sub>	560Ω RC1/4L	-308-00	R <sub>426</sub>	18Ω "
1-203-187-00	R <sub>201</sub>	27 KΩ RD1/4L	-006-00	R <sub>427</sub>	27Ω RD1/4L
-187-00	R <sub>202</sub>	6.8 KΩ RD1/16L	-334-00	R <sub>428</sub>	180Ω "
-182-00	R <sub>203</sub>	6.8 KΩ "	-400-00	R <sub>501</sub>	120 KΩ RD1/8RL
-184-00	R <sub>204</sub>	1 KΩ "	-386-00	R <sub>502</sub>	15 KΩ "
-187-00	R <sub>205</sub>	2.2 KΩ "	-375-00	R <sub>503</sub>	4.3 KΩ "
-185-00	R <sub>206</sub>	6.8 KΩ RD1/16L	-377-00	R <sub>504</sub>	5.1 KΩ "
-192-00	R <sub>207</sub>	4.7 KΩ "	-370-00	R <sub>505</sub>	2.2 KΩ "
-182-00	R <sub>208</sub>	15 KΩ "	-354-00	R <sub>506</sub>	33Ω "
-421-00	R <sub>209</sub>	1 KΩ "	-367-00	R <sub>507</sub>	1 KΩ "
-425-00	R <sub>210</sub>	1 KΩ RD1/16RL	-408-00	R <sub>508</sub>	8.2 KΩ "
-185-00	R <sub>211</sub>	3.3 KΩ RD1/16L	-383-00	R <sub>509</sub>	10 KΩ "
-190-00	R <sub>212</sub>	4.7 KΩ "	-100-00	R <sub>510</sub>	100 KΩ RD1/4L
1-201-160-00	R <sub>213</sub>	10 KΩ "	1-201-596-00	R <sub>511</sub>	3.3 MΩ RC1/2L
1-203-181-00	R <sub>214</sub>	42Ω RC1/10L	1-203-011-00	R <sub>512</sub>	100Ω RD1/4RL
-181-00	R <sub>215</sub>	390Ω RD1/16L	-387-00	R <sub>601</sub>	22 KΩ RD1/8L
-339-00	R <sub>216</sub>	390Ω "	-383-00	R <sub>602</sub>	10 KΩ "
-187-00	R <sub>217</sub>	1.8 KΩ RD1/16RL	-759-00	R <sub>603</sub>	120 KΩ "
-185-00	R <sub>218</sub>	6.8 KΩ RD1/16L	-411-00	R <sub>604</sub>	330 KΩ "
1-201-457-00	R <sub>301</sub>	4.7 KΩ "	1-203-377-00	R <sub>605</sub>	5.1 KΩ RD1/8RL
1-203-145-00	R <sub>302</sub>	1.2 KΩ RC1/8L	-383-00	R <sub>606</sub>	10 KΩ "
-357-00	R <sub>303</sub>	150Ω RD1/8RL	-368-00	R <sub>607</sub>	1.2 KΩ "
1-201-123-00	R <sub>304</sub>	100Ω "	-368-00	R <sub>608</sub>	1.2 KΩ "
1-203-414-00	R <sub>305</sub>	6.8 KΩ RC1/8L	-368-00	R <sub>609</sub>	1.2 KΩ "
1-201-108-00	R <sub>306</sub>	47Ω RD1/8RL	-357-00	R <sub>610</sub>	1.2 KΩ "
1-203-414-00	R <sub>307</sub>	10 KΩ RC1/8L	-368-00	R <sub>611</sub>	100Ω "
-368-00	R <sub>308</sub>	47Ω RD1/8RL	-561-00	R <sub>612</sub>	1.2 KΩ RD1/8RL
-373-00	R <sub>309</sub>	1.2 KΩ "	-387-00	R <sub>613</sub>	470Ω "
1-203-414-00	R <sub>310</sub>	3.3 KΩ "	-385-00	R <sub>614</sub>	22 KΩ "
-368-00	R <sub>311</sub>	47Ω RD1/8RL	-378-00	R <sub>615</sub>	15 KΩ "
-370-00	R <sub>312</sub>	1.2 KΩ "	-405-00	R <sub>701</sub>	5.6 KΩ "
-412-00	R <sub>313</sub>	2.2 KΩ "	-378-00	R <sub>702</sub>	1.5 KΩ "
-357-00	R <sub>314</sub>	390Ω "	-397-00	R <sub>703</sub>	82 KΩ "
-383-00	R <sub>315</sub>	100Ω "	-360-00	R <sub>704</sub>	330Ω "
-361-00	R <sub>316</sub>	10 KΩ "	-360-00	R <sub>705</sub>	330Ω "
-372-00	R <sub>317</sub>	470Ω RD1/8RL	-377-00	R <sub>706</sub>	5.1 KΩ "
-368-00	R <sub>318</sub>	2.7 KΩ "	1-207-018-00	R <sub>707</sub>	3Ω RW1/4RL
-404-00	R <sub>319</sub>	1.2 KΩ "	1-203-367-00	R <sub>708</sub>	1 KΩ RD1/8RL
1-201-122-00	R <sub>320</sub>	200Ω "	-778-00	R <sub>709</sub>	2.4 KΩ "
1-203-366-00	R <sub>321</sub>	4.3 KΩ RC1/8L	-375-00	R <sub>710</sub>	4.3 KΩ "
1-201-128-00	R <sub>322</sub>	820Ω RD1/8RL	-316-00	R <sub>711</sub>	510Ω "
-128-00	R <sub>323</sub>	33Ω RC1/8L	-335-00	R <sub>712</sub>	750Ω "
-128-00	R <sub>324</sub>	33Ω "	1-207-018-00	R <sub>713</sub>	3Ω RW1/4RL
1-203-884-00	R <sub>325</sub>	33 KΩ RD1/16L	1-203-857-00	R <sub>714</sub>	620Ω RD1/8RL
-380-00	R <sub>326</sub>	6.2 KΩ RD1/8RL	1-201-147-00	R <sub>715</sub>	18 KΩ RC1/8L
-373-00	R <sub>401</sub>	3.3 KΩ "	1-203-382-00	R <sub>716</sub>	7.5 KΩ RD1/8RL
1-201-123-00	R <sub>402</sub>	3.3 KΩ "	-443-00	R <sub>801</sub>	3 KΩ RD1/8RL
1-203-367-00	R <sub>403</sub>	6.8 KΩ RC1/8L	-857-00	R <sub>802</sub>	620Ω "
-381-00	R <sub>404</sub>	1 KΩ RD1/8RL	-760-00	R <sub>803</sub>	430Ω "
-381-00	R <sub>405</sub>	6.8 KΩ "	1-203-360-00	R <sub>804</sub>	330Ω RD1/8RL
-381-00	R <sub>406</sub>	6.8 KΩ "	1-207-022-00	R <sub>805</sub>	5.6Ω RW1/4RL
1-203-375-00	R <sub>407</sub>	4.3 KΩ RD1/8RL	1-203-386-00	R <sub>806</sub>	18 KΩ RD1/8RL
	R <sub>408</sub>		-384-00	R <sub>807</sub>	12 KΩ "
	R <sub>409</sub>		-399-00	R <sub>808</sub>	100 KΩ "
	R <sub>410</sub>			R <sub>809</sub>	
	R <sub>411</sub>			R <sub>810</sub>	
	R <sub>412</sub>			R <sub>811</sub>	
	R <sub>413</sub>			R <sub>812</sub>	
	R <sub>414</sub>			R <sub>813</sub>	
	R <sub>415</sub>			R <sub>814</sub>	
	R <sub>416</sub>			R <sub>815</sub>	
	R <sub>417</sub>			R <sub>816</sub>	
	R <sub>418</sub>			R <sub>817</sub>	
	R <sub>419</sub>			R <sub>818</sub>	
	R <sub>420</sub>			R <sub>819</sub>	
	R <sub>421</sub>			R <sub>820</sub>	
	R <sub>422</sub>			R <sub>821</sub>	
	R <sub>423</sub>			R <sub>822</sub>	
	R <sub>424</sub>			R <sub>823</sub>	
	R <sub>425</sub>			R <sub>824</sub>	
	R <sub>426</sub>			R <sub>825</sub>	
	R <sub>427</sub>			R <sub>826</sub>	
	R <sub>428</sub>			R <sub>827</sub>	
	R <sub>501</sub>			R <sub>828</sub>	
	R <sub>502</sub>			R <sub>829</sub>	
	R <sub>503</sub>			R <sub>830</sub>	
	R <sub>504</sub>			R <sub>831</sub>	
	R <sub>505</sub>			R <sub>832</sub>	
	R <sub>506</sub>			R <sub>833</sub>	
	R <sub>507</sub>			R <sub>834</sub>	
	R <sub>508</sub>			R <sub>835</sub>	
	R <sub>509</sub>			R <sub>836</sub>	
	R <sub>510</sub>			R <sub>837</sub>	
	R <sub>511</sub>			R <sub>838</sub>	
	R <sub>512</sub>			R <sub>839</sub>	
	R <sub>601</sub>			R <sub>840</sub>	
	R <sub>602</sub>			R <sub>841</sub>	
	R <sub>603</sub>			R <sub>842</sub>	
	R <sub>604</sub>			R <sub>843</sub>	
	R <sub>605</sub>			R <sub>844</sub>	
	R <sub>606</sub>			R <sub>845</sub>	
	R <sub>607</sub>			R <sub>846</sub>	
	R <sub>608</sub>			R <sub>847</sub>	
	R <sub>609</sub>			R <sub>848</sub>	
	R <sub>610</sub>			R <sub>849</sub>	
	R <sub>611</sub>			R <sub>850</sub>	
	R <sub>612</sub>			R <sub>851</sub>	
	R <sub>613</sub>			R <sub>852</sub>	
	R <sub>614</sub>			R <sub>853</sub>	
	R <sub>615</sub>			R <sub>854</sub>	
	R <sub>701</sub>			R <sub>855</sub>	
	R <sub>702</sub>			R <sub>856</sub>	
	R <sub>703</sub>			R <sub>857</sub>	
	R <sub>704</sub>			R <sub>858</sub>	
	R <sub>705</sub>			R <sub>859</sub>	
	R <sub>706</sub>			R <sub>860</sub>	
	R <sub>707</sub>			R <sub>861</sub>	
	R <sub>708</sub>			R <sub>862</sub>	
	R <sub>709</sub>			R <sub>863</sub>	
	R <sub>710</sub>			R <sub>864</sub>	
	R <sub>711</sub>			R <sub>865</sub>	
	R <sub>712</sub>			R <sub>866</sub>	
	R <sub>713</sub>			R <sub>867</sub>	
	R <sub>714</sub>			R <sub>868</sub>	
	R <sub>715</sub>			R <sub>869</sub>	
	R <sub>716</sub>			R <sub>870</sub>	
	R <sub>801</sub>			R <sub>871</sub>	
	R <sub>802</sub>			R <sub>872</sub>	
	R <sub>803</sub>			R <sub>873</sub>	
	R <sub>804</sub>			R <sub>874</sub>	
	R <sub>805</sub>			R <sub>875</sub>	
	R <sub>806</sub>			R <sub>876</sub>	
	R <sub>807</sub>			R <sub>877</sub>	
	R <sub>808</sub>			R <sub>878</sub>	
	R <sub>809</sub>			R <sub>879</sub>	
	R <sub>810</sub>			R <sub>880</sub>	

Part No.	Symbol	Description	Part No.	Symbol	Description
1-203-031-00	R <sub>810</sub>	1 KΩ RD1/4L	1-101-004-01	C <sub>405</sub>	0.01 μF Ceramic
1-203-367-00	R <sub>811</sub>	1 KΩ RD1/8RL	-004-01	C <sub>406</sub>	0.01 μF "
-867-00	R <sub>812</sub>	390 KΩ "	-085-01	C <sub>407</sub>	6 PF "
-868-00	R <sub>814</sub>	620 KΩ "	-129-01	C <sub>408</sub>	40 PF "
1-201-455-11	R <sub>901</sub>	1.5 MΩ RC1/2L	-004-01	C <sub>409</sub>	0.01 μF "
1-203-148-00	R <sub>902</sub>	47 Ω RD1/4L	-deleted-	C <sub>410</sub>	400 PF Styrol
1-201-455-11	R <sub>903</sub>	1.5 MΩ RC1/2L	1-103-023-11	C <sub>411</sub>	400 PF Styrol
1-101-001-01	C <sub>101</sub>	0.001 μF Ceramic	1-101-118-01	C <sub>412</sub>	0.01 μF Ceramic
1-101-001-01	C <sub>102</sub>	-deleted-	-118-01	C <sub>413</sub>	0.01 μF "
1-101-001-01	C <sub>108</sub>	0.001 μF Ceramic	-086-01	C <sub>414</sub>	0.1 μF "
1-101-076-00	C <sub>201</sub>	-deleted-	1-121-104-01	C <sub>415</sub>	10 μF 6 WV Electrolytic
-076-00	C <sub>202</sub>	0.5 PF Ceramic	-102-01	C <sub>416</sub>	30 μF " "
-041-00	C <sub>203</sub>	50 PF "	-120-01	C <sub>417</sub>	100 μF 12 WV "
1-141-055-00	C <sub>204</sub>	50 PF "	-128-01	C <sub>418</sub>	50 μF 6 WV "
-055-00	C <sub>205</sub>	Cylindrical Trimmer Capacitor	-122-01	C <sub>419</sub>	50 μF 12 WV "
-055-00	C <sub>210</sub>	" " "	-121-01	C <sub>420</sub>	200 μF 12 WV "
-055-00	C <sub>211</sub>	" " "	1-121-118-01	C <sub>501</sub>	10 μF 12 WV Electrolytic
-055-00	C <sub>218</sub>	" " "	-118-01	C <sub>502</sub>	10 μF " "
-055-00	C <sub>224</sub>	" " "	1-105-033-00	C <sub>503</sub>	0.005 μF Mylar (MFL)
-055-00	C <sub>225</sub>	" " "	1-121-155-01	C <sub>504</sub>	100 μF 6 WV Electrolytic
1-101-039-00	C <sub>206</sub>	10 PF Ceramic	1-105-077-00	C <sub>505</sub>	0.2 μF Mylar (MFL)
-040-00	C <sub>207</sub>	20 PF "	-035-00	C <sub>506</sub>	0.05 μF " "
-043-00	C <sub>208</sub>	0.001 μF " "	-036-00	C <sub>507</sub>	0.05 μF " "
-036-00	C <sub>209</sub>	3 PF "	1-127-906-00	C <sub>601</sub>	1 μF 10 WV Electrolytic (Alox)
-039-00	C <sub>212</sub>	10 PF "	-907-00	C <sub>602</sub>	3 μF 6 WV " "
-035-00	C <sub>218</sub>	2 PF "	1-105-035-00	C <sub>603</sub>	0.05 μF Mylar (MFL)
-043-00	C <sub>214</sub>	0.001 μF " "	1-127-906-00	C <sub>604</sub>	1 μF 10 WV Electrolytic (Alox)
-041-00	C <sub>215</sub>	50 PF "	1-105-018-00	C <sub>605</sub>	0.03 μF Mylar (MFL)
1-141-054-00	C <sub>215</sub>	Cylindrical Trimmer Capacitor (Fine Tuning)	-063-00	C <sub>606</sub>	0.01 μF " "
1-101-067-00	C <sub>217</sub>	3 PF Ceramic	1-127-906-00	C <sub>607</sub>	1 μF 10 WV Electrolytic (Alox)
-043-00	C <sub>219</sub>	0.001 μF " "	-deleted-	C <sub>608</sub>	-deleted-
-044-00	C <sub>220</sub>	0.005 μF " "	1-105-076-00	C <sub>609</sub>	0.1 μF Mylar (MFL)
-040-00	C <sub>221</sub>	20 PF " "	-076-00	C <sub>610</sub>	0.1 μF " "
-038-00	C <sub>222</sub>	5 PF " "	1-127-908-00	C <sub>611</sub>	3 μF 10 WV Electrolytic (Alox)
-020-00	C <sub>223</sub>	0.005 μF " "	1-127-905-01	C <sub>701</sub>	5 μF 10 WV Electrolytic (Alox)
1-101-041-00	C <sub>227</sub>	50 PF Ceramic	1-121-141-05	C <sub>702</sub>	100 μF 12 WV Electrolytic
-645-00	C <sub>301</sub>	10 PF Ceramic	-118-01	C <sub>703</sub>	10 μF " "
-004-01	C <sub>302</sub>	0.01 μF " "	-122-00	C <sub>704</sub>	50 μF " "
1-121-106-01	C <sub>303</sub>	5 μF 6 WV Electrolytic	-161-05	C <sub>705</sub>	500 μF 6 WV " "
1-101-046-01	C <sub>304</sub>	2 PF Ceramic	-122-00	C <sub>706</sub>	50 μF 12 WV " "
-114-01	C <sub>305</sub>	15 PF " "	-164-00	C <sub>707</sub>	10 μF " "
-046-01	C <sub>306</sub>	2 PF " "	-136-00	C <sub>708</sub>	2 μF 50 WV " "
-111-00	C <sub>307</sub>	20 PF " "	1-105-037-00	C <sub>709</sub>	0.2 μF Mylar (MFL)
-004-01	C <sub>308</sub>	0.01 μF " "	1-105-034-00	C <sub>801</sub>	0.02 μF Mylar (MFL)
1-121-145-01	C <sub>309</sub>	1 μF 6 WV Electrolytic	-035-00	C <sub>802</sub>	0.05 μF " "
1-101-036-01	C <sub>310</sub>	3 PF Ceramic	1-105-076-00	C <sub>904</sub>	0.1 μF Mylar (MFL)
-114-00	C <sub>311</sub>	15 PF " "	1-113-112-00	C <sub>905</sub>	0.04 μF PS
-004-01	C <sub>312</sub>	0.01 μF " "	-107-00	C <sub>906</sub>	0.02 μF "
1-121-106-01	C <sub>313</sub>	5 μF 6 WV Electrolytic	1-105-035-00	C <sub>907</sub>	0.05 μF Mylar (MFL)
1-101-046-01	C <sub>314</sub>	2 PF Ceramic	1-121-148-01	C <sub>908</sub>	1 μF 100 WV Electrolytic
-649-01	C <sub>315</sub>	12 PF " "	1-115-046-00	C <sub>909</sub>	0.05 μF 400 WV Oil
1-121-106-01	C <sub>316</sub>	5 μF 6 WV Electrolytic	-deleted-	C <sub>910</sub>	-deleted-
1-101-004-01	C <sub>317</sub>	0.01 μF Ceramic	-161-05	C <sub>911</sub>	-deleted-
1-121-128-01	C <sub>318</sub>	50 μF 6 WV Electrolytic	-122-00	C <sub>912</sub>	-deleted-
1-101-046-01	C <sub>319</sub>	2 PF Ceramic	1-105-035-00	C <sub>918</sub>	0.05 μF Mylar (MFL)
-645-00	C <sub>320</sub>	10 PF " "	-063-00	C <sub>914</sub>	0.01 μF " "
1-121-121-01	C <sub>321</sub>	200 μF 12 WV Electrolytic	1-109-010-00	C <sub>901</sub>	200 PF Mica
1-101-069-01	C <sub>322</sub>	4 PF Ceramic	-010-00	C <sub>902</sub>	200 PF "
1-103-096-00	C <sub>323</sub>	6 PF Styrol	1-119-071-05	C <sub>903</sub>	4000 μF 15 WV Electrolytic
1-101-424-00	C <sub>324</sub>	500 PF Ceramic	-071-05	C <sub>904</sub>	4000 μF " "
-058-01	C <sub>325</sub>	0.005 μF " "	1-101-05	C <sub>905</sub>	100 μF 12 WV " "
-004-01	C <sub>326</sub>	0.01 μF " "	1-119-043-05	C <sub>906</sub>	200 μF " "
-086-01	C <sub>327</sub>	0.1 μF " "	1-131-002-11	C <sub>907</sub>	50 μF " " (Tantalum)
1-121-116-01	C <sub>328</sub>	1 μF 12 WV Electrolytic	1-127-909-11	C <sub>908</sub>	0.5 μF 25 WV " (Alox)
1-101-004-01	C <sub>329</sub>	0.01 μF Ceramic	Transistor	X <sub>201</sub>	2SA161 (RF AMP)
-112-01	C <sub>401</sub>	50 PF Ceramic	X <sub>202</sub>	2SA161 (MIX)	
-004-01	C <sub>402</sub>	0.01 μF " "	X <sub>203</sub>	2SA161 (OSC)	
-069-01	C <sub>403</sub>	4 PF " "	X <sub>1</sub>	2SA70 (1st VIF AMP)	
-319-01	C <sub>404</sub>	0 PF " "	X <sub>2</sub>	2SA70 (2nd VIF AMP)	
			X <sub>3</sub>	2SA70 (3rd VIF AMP)	
			X <sub>4</sub>	2SA70 (4th VIF AMP)	

Part No.	Symbol	Description	Part No.	Symbol	Description
	X <sub>5</sub>	2SA70 (AGC AMP)	1-800-001-00	Th <sub>201</sub>	Thermistor S-10
	X <sub>6</sub>	25C73 (DC AMP)	8-860-003-00	Th <sub>401</sub>	S-90
	X <sub>7</sub>	2SA70 (1st SIF AMP)	-005-00	Th <sub>701</sub>	S-300
	X <sub>8</sub>	2SA70 (2nd SIF AMP)	1-525-039-00		HV Rectifier
	X <sub>9</sub>	2SD64 (AF DRIVE AMP)			IDK1
	X <sub>10</sub>	2SB52 (AF POWER AMP)	1-403-401-00	VIFT <sub>1</sub>	Coil and Transformers
	X <sub>11</sub>	2SB52 ( " " )	-426-11	VIFT <sub>2</sub>	Video IF Transformer
	X <sub>12</sub>	2SA60 (VD DRIVE)	-424-02	VIFT <sub>3</sub>	" "
	X <sub>13</sub>	25C15 (VD OUT)	-425-02	VIFT <sub>4</sub>	" "
	X <sub>14</sub>	25C73 (SYNC SEP. AMP, NOISE LIMIT)	-417-02	VIFT <sub>5</sub>	" "
	X <sub>15</sub>	2SB52 (SYNC SPLIT)	-418-02	VIFT <sub>6</sub>	" "
	X <sub>16</sub>	2SB51 (VERT OSC)	-419-02	VIFT <sub>7</sub>	" "
	X <sub>17</sub>	2SB51 (VERT DRIVE)	-306-02	SIFT <sub>1</sub>	Sound IF Transformer
	X <sub>18</sub>	25C140 (VERT POWER)	-310-02	SIFT <sub>2</sub>	" "
	X <sub>19</sub>	25C140 (HOR OSC)	-048-02	SIFT <sub>3</sub>	IF Transformer for FM Detector
	X <sub>20</sub>	25C140 (HOR DRIVE)	X-44012-54-0	L <sub>201-204</sub>	Tuner Rotary Coil
	X <sub>21</sub>	2SC41 (HOR POWER)	1-409-001-00	Trap <sub>201</sub>	Video IF Trap Coil
	X <sub>22</sub>	2SD65 (HOR BUFFER)	1-407-001-00	CH <sub>201</sub>	IF Choke Coil
		Diode	-013-02	Trap <sub>1</sub>	Sound Signal Trap
	D <sub>1</sub>	1T22	1-403-420-00	DET	Video Detector Block
	D <sub>2</sub>	1T26			BLOCK
	D <sub>3</sub>	1T26	1-423-048-00	SDT	Sound Driver Transformer
	D <sub>4</sub>	1T23A	1-411-003-11	L <sub>501</sub>	Peaking Coil
	D <sub>5</sub>	1T23A	-002-11	L <sub>502</sub>	Peaking Coil
	D <sub>6</sub>	1T22	-003-11	L <sub>601</sub>	Peaking Coil
	D <sub>7</sub>	1T26	1-421-013-11	L <sub>602</sub>	Horizontal Choke Coil
	D <sub>8</sub>	1T22	1-435-005-00	VBT	Vertical Blocking Transformer
	D <sub>9</sub>	1T22	1-421-106-01	VCH	Vertical Output Choke Coil
	D <sub>10</sub>	1T22	1-413-004-00	HSC	Stabilizing Coil for Horizontal Sweep
	D <sub>11</sub>	1T22	1-435-007-12	HBT	Horizontal Blocking Transformer
	D <sub>12</sub>	1T22	1-437-002-00	HDT	Horizontal Driver Transformer
	D <sub>13</sub>	1S205	1-439-003-01	HOT	Horizontal Output Transformer
	D <sub>14</sub>	1S125	1-421-008-13	BCH	Filter Choke Coil for Power Supply
	D <sub>15</sub>	S2A30	1-441-063-11	PT	Power Transformer
	D <sub>16</sub>	S2A30			
1-531-103-02	D <sub>17-20</sub>	Selenium Rectifier			

### Electrical Parts List (B) for TV 5-303E

Part No.	Description	Qty	Part No.	Description	Qty
	<b>A. General</b>		4-002-710-00	Terminal Strip for Yoke	(3)
	<b>Cabinet &amp; Appearance Items</b>		1-535-009-00	Connector Tip D	(2)
1-507-047-00	Twin Earphone Jack	1	7-621-255-22	Screw ⊕ RK 2×4	(1)
-065-00	Antenna Jack Assembly	1	1-105-035-00	Mylar Capacitor 0.05 μF 100 WV	(1)
	<b>Main Block</b>		1-203-316-00	Carbon Resistor RD1/8RL 510 Ω	(2)
1-502-068-00	Speaker	1		<b>High Voltage Block</b>	
1-526-052-03	Socket for Picture Tube	1	1-453-001-00	High Voltage Block Assembly, including	1
-02			4-002-698-00	High Voltage Block Case	(1)
1-507-203-00	Multi-Jack for Printed Circuit Board	2	-699-00	High Voltage Block Shield Plate	(1)
1-532-031-11	Fuse (0.2A)	1	-700-00	High Voltage Rectifier Mounting Plate	(1)
1-519-007-01	Neon Lamp	1	-701-00	High Voltage Block Holding Bracket	(1)
-02			-702-00	High Voltage Block Shield Case	(1)
1-513-176-00	Power Switch	1	1-526-102-01	Anode Connector	(1)
1-506-020-00	4 Pole Plug, including	1	4-002-711-02	Anode Connector Cover	(1)
1-533-009-00	Fuse Holder	(2)	-712-03	Anode Connector	(1)
1-514-081-11	Micro-Switch	1	1-439-003-00	Horizontal Output Transformer	(1)
4-002-713-01	Flat Leaf Actuator for Micro-Switch	1	1-525-039-00	High Voltage Rectifier Tube, 1DK1	(3)
1-536-039-00	Two Lug Tie Point for Pilot Lamp Lead	1	1-535-009-00	Connector Tip D	(4)
1-531-103-01	Selenium Rectifier	1	Diode S2A30		(1)
-02			1-101-034-00	Ceramic Capacitor 500 PF 6 KV	(3)
-03			7-622-105-01	Nut 2φ	(2)
1-536-045-11	2P Lug	1		High Voltage Block Case Fix Screw	(2)
	<b>Accessory</b>			<b>Deflection Block</b>	
1-504-010-02	Earphone	1	X-40029-62-1	Mounted Deflection Circuit Board	1
1-534-041-00	AC Power Cord	1	1-506-108-00	Circuit Connecting Pin	7
X-40029-06-1	Spare fuse Assembly	1	1-538-111-01	Deflection Circuit Board	1
1-534-042-03	Extension Cord	1		<b>Video &amp; Sound Signal Block</b>	
	<b>Deflection Yoke</b>		X-40029-61-1	Mounted Video & Sound Signal Circuit Board	1
1-451-003-00	Deflection Yoke Assembly, including	1	1-538-110-02	Video & Sound Signal Circuit Board	1
4-002-703-00	Yoke Cover	(1)	1-506-108-00	Circuit Connecting Pin	2
-704-00	Yoke Core Clamp	(1)	1-507-103-00	Connector Tip K	4
-705-00	Centering Magnet Assembly (A)	(1)		<b>B. Tube</b>	
-706-00	" " " (B)	(1)	73110510	Picture Tube 140CB4	1
-707-00	Centering Magnet Holding Bracket	(1)	1-525-039-00	High Voltage Rectifier Tube, 1DK1	3
-708-00	Yoke Clamp	(1)			
-709-00	Spacer for Centering Magnet	(1)			

—continued—

Part No.	Description	Q'ty	Part No.	Description	Q'ty
<b>C. Wires and Miscellaneous</b> (Minimum Q'ty for Ordering: Meter)					
<b>Main Block</b>					
<b>P. V. C. Wires</b>					
	12/0.18	1.5φ	Red		
	"	"	Orange		
	"	"	Yellow		
	"	"	Green		
	"	"	Blue		
	"	"	Gray		
	"	"	White		
	"	"	Purple		
	"	"	Black		
	"	"	Brown		
	20/0.18	2.0φ	Black		
	"	"	Brown		
	"	"	Red		
	"	"	Gray		
	"	"	White		
				Two Conductor Cable (Shielded) 7/0.12×2	
				Tinned Copper Wire 0.6φ	
				1.0φ	
				<b>Braided Wire</b> 16/14/0.08	
				<b>High Voltage Block &amp; Deflection Block</b>	
				<b>P. V. C. Wires</b>	
				0.6φ Yellow	
				16/0.12 Black	
				20/0.18 Black	
				12/0.18 (Polyethylene)	
				<b>Thermo Contracting Plastic Tube</b> Gray	
				<b>Video &amp; Sound Signal Block</b>	
				<b>P. V. C. Wire</b> 16/0.12 1.6φ Black	
				Two Conductor Cable 7/0.12×2	

Part No.	Description	Q'ty	Part No.	Description	Q'ty
Y-44012-55-1	Tuner Block	1	X-40029-62-1	Deflection Block (Mounted Circuit Board)	1
X-40029-61-1	Video & Sound Signal Block (Mounted Circuit Board)	1	1-453-001-01	High Voltage Block	1
			1-451-003-00	Deflection Yoke	1

**Mechanical Parts List for TV 5-303E**

Part No.	Description	Q'ty	Part No.	Description	Q'ty
<b>A. General</b>					
<b>Cabinet &amp; Appearance Items</b>					
X-40026-02-0	Cabinet (Front) Assembly, including	1	X-40026-04-8	Cabinet (Back) Assembly	1
4-002-603-02	Cabinet (Front)	(1)	4-002-795-03	Case Label	1
-604-01	Picture Tube Mask	(1)	-714-00	Telescopic Antenna Catch	1
-765-01	Picture Tube Protector	1	X-40026-05-0	Carrying Handle Assembly, including	1
-611-00	Antenna Bushing	1	4-002-620-01	Carrying Handle	(1)
-781-00	Dust-Proof Rubber	1	-622-00	Ornamental Leather for Handle	(2)
-782-00	Spacer (Upper) for Picture Tube	1	-733-00	Carrying Handle Holding Screw	(2)
-783-00	Spacer (Lower) for Picture Tube	1	X-40026-06-2	Table Stand Assembly	1
-784-00	Deflection Yoke Spacer	1	-730-00	Rubber Foot	2
X-40026-50-0	Picture Tube Clamp Assembly, including	1	X-40026-43-0	Channel Selector Knob Assembly	1
4-002-778-00	Picture Tube Clamp	(1)	X-40026-10-2	Fine Tuning Knob Assembly	1
-779-00	Picture Tube Fixing Bracket	(2)	X-40026-11-0	Volume Control Knob Assembly	1
-780-00	Grounding Metal for Picture Tube	(1)	4-002-635-00	Control Knob (Hor. Hold. Brightness, Contrast)	3
X-40026-41-1	Telescopic Antenna Assembly, including	1	-762-00	Vertical Hold Control Knob	1
4-002-716-00	Telescopic Antenna Holding Bracket	(1)	-742-00	"SONY" Badge	1
-718-00	Telescopic Antenna Connecting Lug	(1)	-761-00	Control Panel	1
-715-00	Compressed Fiber Washer for Telescopic Antenna	(1)		<b>Main Block</b>	
-717-00	Telescopic Antenna Bottom Insulator	(1)	X-40026-14-4	Chassis Assembly	1
-727-00	Telescopic Antenna Holding Nut	(1)	X-40026-15-4	Speaker Holding Plate Assembly, including	1
-728-00	Lock Nut for Telescopic Antenna	(1)	4-002-644-04	Speaker Holding Plate	(1)
7-623-412-01	Lock Washer (5φ) for Telescopic Antenna	(1)	-646-01	Earphone Jack Plate	(1)
4-002-764-00	Telescopic Antenna Tip	(1)	-647-00	Multi-Jack Holding Bracket	(2)
			-648-01	Adjustable Clamp for Electrolytic Capacitor	(1)
			X-40026-16-2	4 Pole Plug Mounting Bracket Assembly	1
			4-002-653-01	Micro-Switch Contacting Pin	1

—continued—

Part No.	Description	Q'ty	Part No.	Description	Q'ty
4-002-674-00	Micro-Switch Mounting Plate	1		<b>Spring Washer</b>	
-649-00	Neon Lamp Holder	1	7-623-210-22	4φ (for Carrying Handle)	2
	<b>Video &amp; Sound Signal Block</b>			<b>Nut</b>	
X-40026-66-0	Shield Plate Assembly	1	7-622-307-02	2.6φ (for Table Stand)	2
	<b>Deflection Block</b>			<b>Main Block</b>	
X-40026-01-0	Deflection Circuit Board Assembly, including	1		<b>Screw</b>	
4-002-680-01	Heat Sink for Hor. Power Transistor (A)	(1)	7-621-561-42	(+ K 3φ×6 (for Power Transformer)	1
-681-01	Heat Sink for Hor. Power Transistor (B)	(1)	-32	(+ K 3φ×5 (for 4 Pole Plug)	3
-682-02	Heat Sink for Vert. Power Transistor (A)	(1)	-259-62	(+ P 2.6φ×10 (for Earphone)	2
-683-00	Heat Sink for Vert. Power Transistor (B)	(1)	-261-32	(+ P 3φ×5 (for Multi-Jack, 4 Pole Plug, Speaker, High Voltage Block, Power Switch)	14
-684-00	Insulator for Heat Sink (Vert.)	(1)	-42	(+ P 3φ×6 (for Power Transformer)	1
-685-00	Spacer for Heat Sink	(2)	-12	(+ P 3φ×3 (for Neon Lamp Holder)	1
-686-01	Black Sheet on Deflection Circuit Board	(1)	-22	(+ P 3φ×4 (Adjustable Clamp for Electrolytic Capacitor)	2
	<b>Accessory</b>		-62	(+ P 3φ×10 (for Adjustable Clamp for Electrolytic Capacitor)	1
X-44900-01-0	Polyethylene Bag for Silicone Cloth	1	-111-42	— R 3φ×6 (for Tuner)	2
4-002-766-00	Carrying Bag	1	-361-32	— F 3φ×5 (for Chassis Mask)	1
-775-00	Carton for Carrying Bag	1	4-002-737-00	(+ P 3φ×23 (for Selenium Rectifier)	1
-771-00	Foam Cushion for Carrying Bag	1		<b>Lock Washer</b>	
-772-00	Styro-Foam Cushion (Back)	1	7-623-408-01	3φ (for Selenium Rectifier & Tuner)	7
-773-00	" " (Bottom)	1		<b>Spring Washer</b>	
-774-00	" " (Front)	1	7-623-207-12	2.6φ (for Earphone)	2
-769-00	Polyethylene Bag	1		<b>Washer</b>	
-770-00	Polyethylene Bag for Carrying Bag	1	4-002-785-00	3φ (for Video & Sound Signal Circuit Board)	1
-667-00	Accessory Case	1		<b>Nut</b>	
4-495-008-53	Instruction Manual	1	7-622-107-02	2.6φ (for Earphone)	2
4-002-796-50	Caution Card	1		<b>Deflection Block</b>	
				<b>Screws</b>	
				(+ P 3φ×8 (for Transistor)	2
				(+ P 2φ×8 (for Transistor)	4
				(+ P 2φ×6 (for Heat Sink)	2
				(+ K 2φ×5 (for Deflection Circuit Board)	3
				<b>Lock Washer</b>	
				3φ (for Transistor)	2
				<b>Nuts</b>	
				3φ (for Transistor)	2
				2φ (for Transistor)	4
				<b>Video &amp; Sound Signal Block</b>	
				<b>Screws</b>	
				(+ P 3φ×8 (for Video & Sound Signal Circuit Board)	1
				(+ P 3φ×5 (for Video & Sound Signal Circuit Board)	1
				(+ P 4φ×7 (for Carrying Handle)	2

**Sony Corporation**

© 1968

78B0403-3

Printed in Japan



Schematic Diagram for Power Supply Block

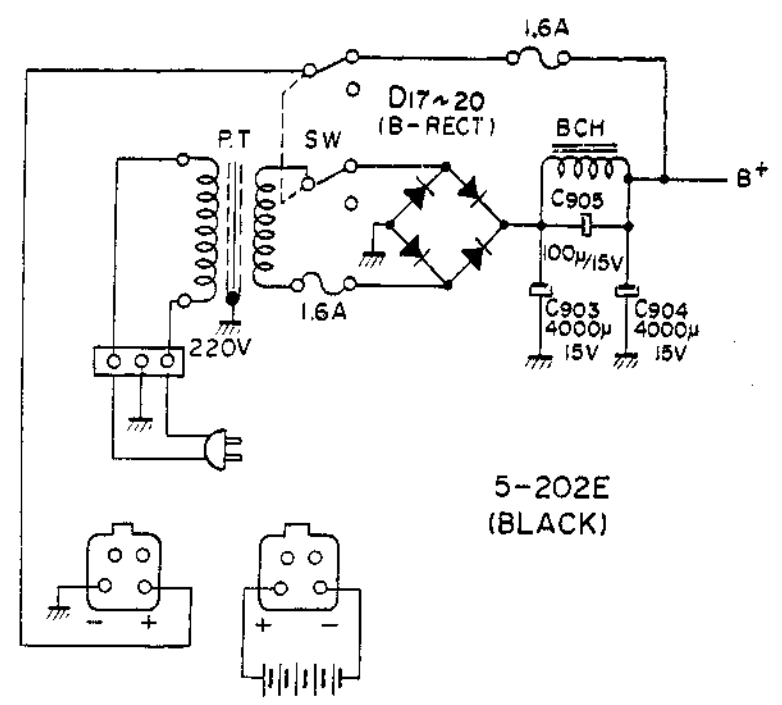

5-202E (BLACK)

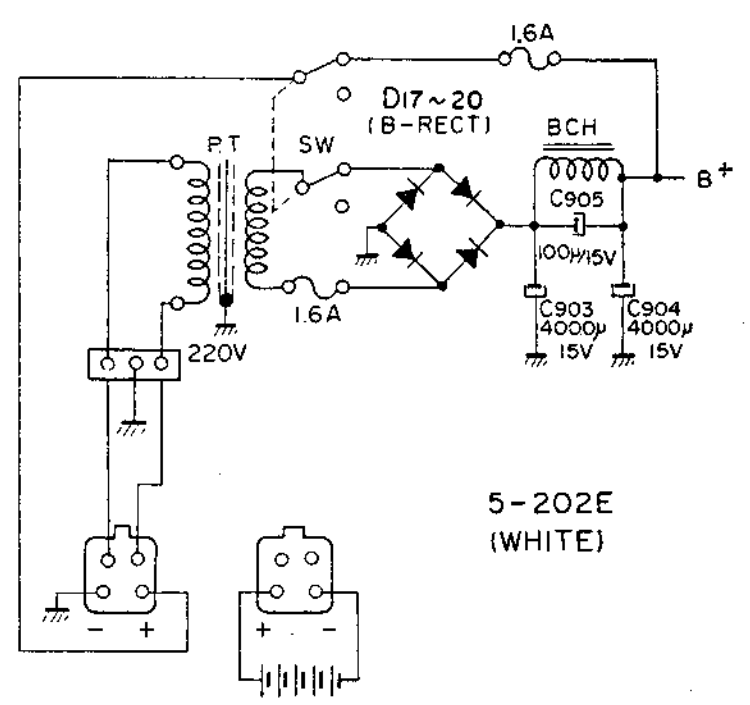

5-202E (WHITE)

# SONY 5-202E CIRCUIT SCHEMATIC

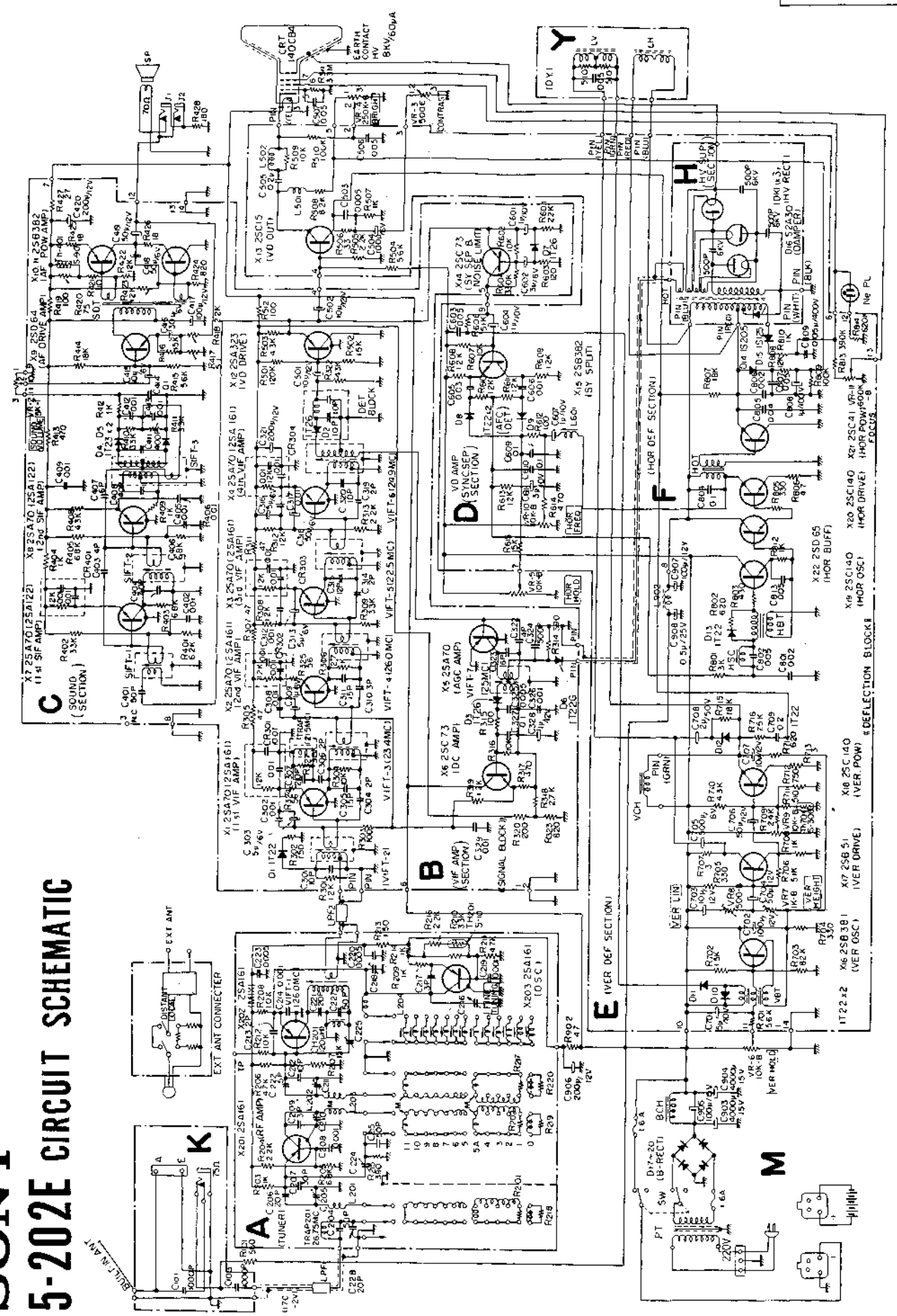

### NOTE for TV 5-202E

SONY Micro TV Model 5-202E is specially made for the North European countries (Denmark, Norway and Sweden) and satisfies DEMKO, SEMKO and NEMKO Specifications. All the features of the 5-202E are entirely same as 5-303E, which is also made for Continental Europe except for the points explained below. Therefore please refer to the Servicing Guide for 5-303E when the set is repaired.

1. Difference between 5-202E and 5-303E.

	5-202E	5-202E	5-303E
	<u>Black</u>	<u>White</u>	
Battery Charger	NO	NO	Built-in
AC Power Cord	fixed	removable	removable

2. Parts List for 5-202E (Special Parts only)

<u>Part No.</u>	<u>Description</u>	<u>Q'ty per one set</u>
1-421-024-11	Filter Choke Coil	1
1-441-099-11	Power Transformer	1
1-506-056-11	4 Pole Plug for 5-202E (White)	1
X-40030-59-1	4 Pole Plug for 5-202E (Black)	1
1-532-037-11	Fuse 1.6A	1
1-534-055-11	AC Power Cord	1