

# TFM-3750W

USA Model

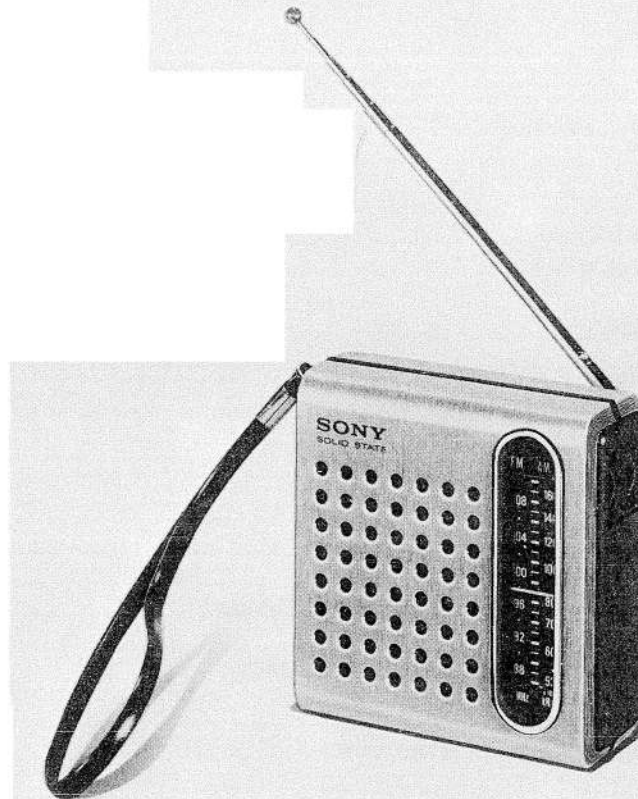

## FM/AM PORTABLE RADIO

### SPECIFICATIONS

<b>Circuit:</b>	9-transistor, 5-diode 2-band superheterodyne	<b>Maximum Power Output:</b>	320 mW
<b>Frequency Ranges:</b>	FM 87.5 ~ 108 MHz (3.43 ~ 2.78 m) AM 530 ~ 1,605 kHz (566 ~ 187 m)	<b>Current Drain at No Signal:</b>	FM 17 mA AM 14 mA
<b>Intermediate Frequencies:</b>	FM 10.7 MHz AM 455 kHz	<b>Speaker:</b>	2 1/4" (57.2 mm) dia PM dynamic, 8 Ω
<b>Antennas:</b>	FM built-in telescopic antenna AM built-in ferrite bar antenna	<b>Power Requirements:</b>	9 V DC battery JIS 006P or EVEREADY 216 or RAY-O-VAC 1604 or equivalent
<b>Sensitivity:</b>	FM 5 μV (14 dB) at S/N = 30 dB AM 100 μV/m (40 dB/m)	<b>Dimensions:</b>	3 7/8" (W) x 3 7/8" (H) x 1 7/8" (D) 100 mm (W) x 100 mm (H) x 48.3 mm (D)
<b>Selectivity:</b>	20 dB at ± 10 kHz off-resonance at 1,000 kHz	<b>Weight:</b>	11.6 oz (330 g) with battery

**SONY**<sup>®</sup>  
**SERVICE MANUAL**

## TABLE OF CONTENTS

<u>Section</u>	<u>Title</u>	<u>Page</u>
	Specifications . . . . .	1
	Hardware Nomenclature . . . . .	2
<b>SECTION 1.</b>	<b>OUTLINE</b>	
	1-1. Block Diagram . . . . .	3
	1-2. Internal View . . . . .	3
<b>SECTION 2.</b>	<b>DISASSEMBLY</b>	
	2-1. Rear Cover Ass'y Removal . . . . .	4
	2-2. Printed Circuit board Removal . . . . .	4
	2-3. Dial Cord Stringing . . . . .	4
<b>SECTION 3.</b>	<b>ADJUSTMENTS</b>	
	3-1. AM I-F Alignment . . . . .	5
	3-2. FM I-F Alignment . . . . .	5
	3-3. Frequency Coverage and Tracking Adjustment . . . . .	7
<b>SECTION 4.</b>	<b>SCHEMATIC AND MOUNTING DIAGRAMS</b>	
	4-1. Schematic Diagram . . . . .	9
	4-2. Mounting Diagram - Conductor Side - . . . . .	11
<b>SECTION 5.</b>	<b>EXPLODED VIEW AND PACKING</b>	
	5-1. Exploded View . . . . .	13
	5-2. Packing . . . . .	15
<b>SECTION 6.</b>	<b>ELECTRICAL PARTS LIST</b>	

### — Hardware Nomenclature —

<p><b>P</b> — Pan Head Screw </p>	<p><b>SC</b> — Set Screw </p>
<p><b>PS</b> — Pan Head Screw with Spring Washer </p>	<p><b>E</b> — Retaining Ring (E Washer) </p>
<p><b>K</b> — Flat Countersunk Head Screw </p>	<p>W — Washer</p>
<p><b>B</b> — Binding Head Screw </p>	<p>SW — Spring Washer</p>
<p><b>RK</b> — Oval Countersunk Head Screw </p>	<p>LW — Lock Washer</p>
<p><b>T</b> — Truss Head Screw </p>	<p>N — Nut</p>
<p><b>R</b> — Round Head Screw </p>	<p>— Example —</p>
<p><b>F</b> — Flat Fillister Head Screw </p>	<p>Type of Slot   P 3x10                      Length in mm (L)                      Diameter in mm (D)                      Type of Head  </p>

*When ordering replacement parts, use PART NUMBERS listed in the Parts List or shown in EXPLODED VIEW. The Parts List reference numbers should not be used.*

**Note:** All screws in this service manual are Phillips type (cross recess type) unless otherwise indicated.  
 (—) : slotted head.

SECTION 1  
OUTLINE

1-1. BLOCK DIAGRAM

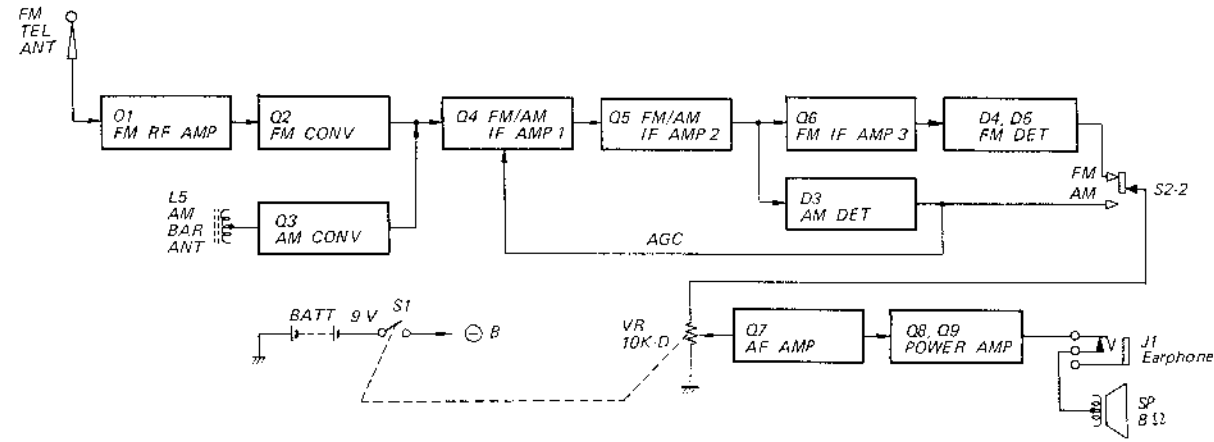

Fig. 1-1.

1-2. INTERNAL VIEW

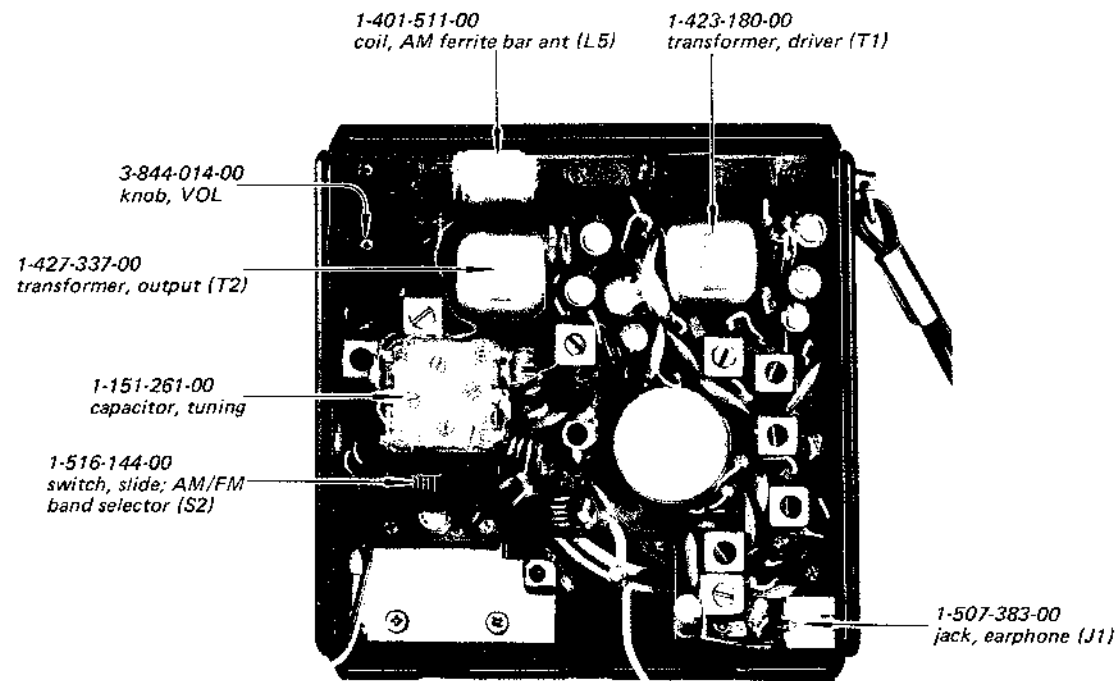
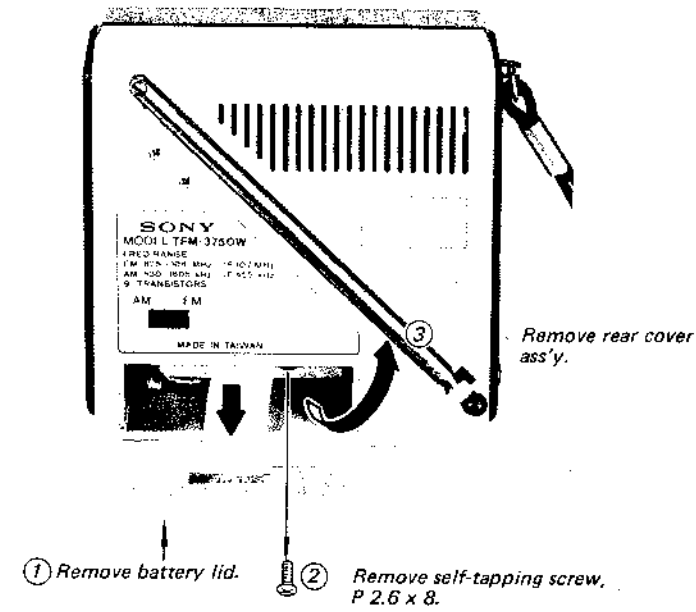

Fig. 1-2.

SECTION 2  
DISASSEMBLY

2-1. REAR COVER ASS'Y REMOVAL

1. Remove the rear cover ass'y, in numerical order as shown in Fig. 2-1.



2-2. PRINTED CIRCUIT BOARD REMOVAL

1. Remove the rear cover ass'y as outlined in 2-1 above and follow the removing steps numerically as follows.

1. Remove four self-tapping screws, P 2.5 x 8.

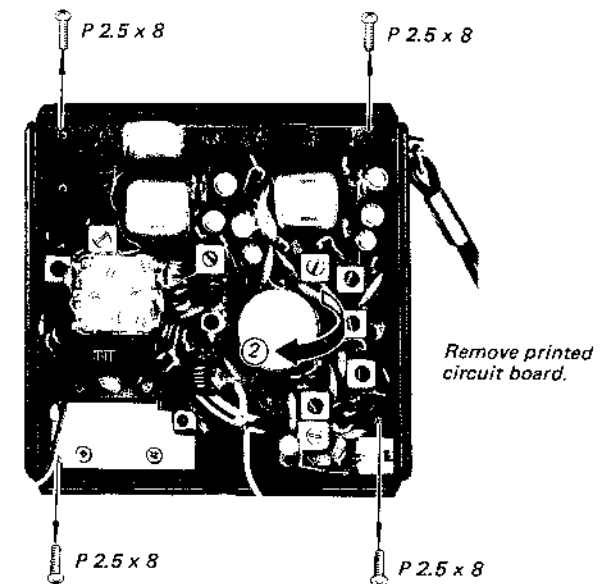

2-3. DIAL CORD STRINGING

1. Remove the dial scale and dial pointer by removing two machine screws, T2 x 5, and two nuts, 2 mm dia, as shown in Fig. 2-4 below.
2. Make dial cord ass'y as shown in Fig. 2-3 below.

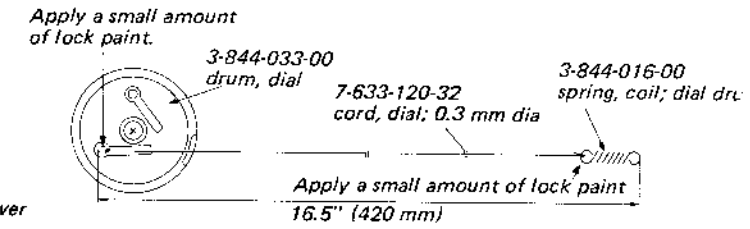

3. String the dial cord numerically as shown in Fig. 2-4 below.

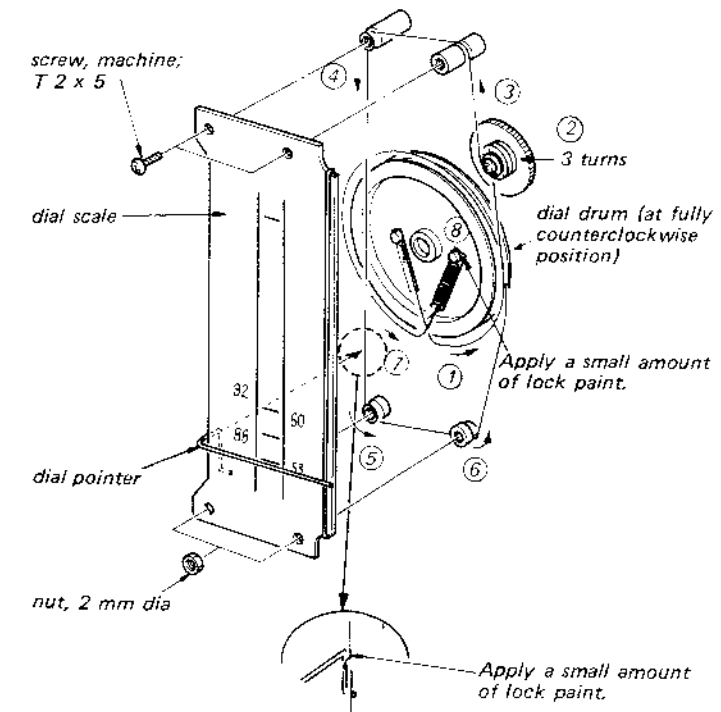

4. Set the dial scale back to the pulley shafts and the dial pointer to the dial cord as illustrated above.

SECTION 3  
ADJUSTMENTS

3-1. AM I-F ALIGNMENT

Test Equipment/Tools Required

- \* Rf signal generator (AM)
- \* Loop antenna
- \* VOM
- \* 8 Ω
- \* Alignment screwdriver

Preparation:

Rf signal generator modulation: 400 Hz, 30 % AM  
 Rf signal generator output level: Usable lowest possible  
 Band selector: AM  
 VOL control setting: Maximum

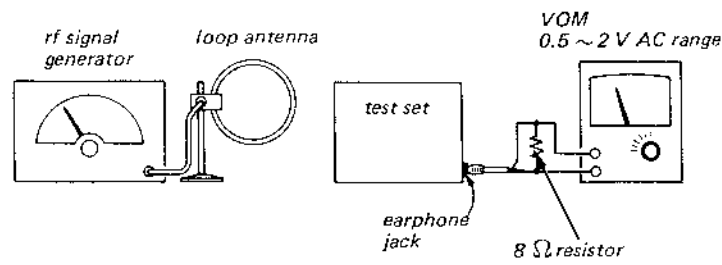

Fig. 3-1. AM i-f alignment, frequency coverage and tracking adjustment setup.

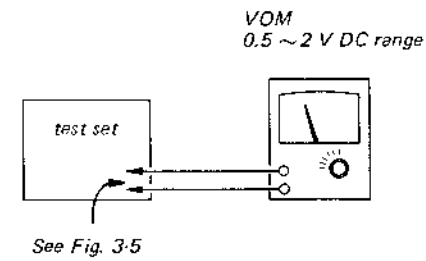

Fig. 3-4. FM i-f alignment setup for step 4.

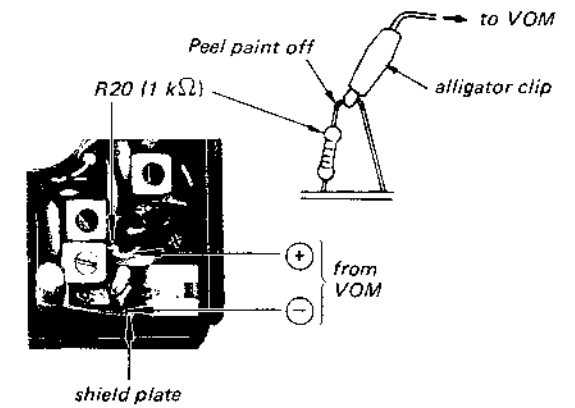

Fig. 3-5. VOM connection for FM i-f alignment, step 4.

Rf Signal Generator Coupling	Rf Signal Generator Frequency	Receiver Dial Knob Setting	Adjust	Remarks
Loop antenna See Fig. 3-1.	455 kHz	No station, no beating position	See Fig. 3-6. 1. IFT A-1 2. IFT A-2 3. IFT A-3	Adjust for maximum meter reading. Repeat adjustment two or three times.

Step	Rf Signal Generator Frequency	Receiver Dial Setting	Adjust	Procedure
1	10.7 MHz with FM modulation	No station, no beating position	Cores of IFT F-1 IFT F-2 IFT F-3 IFT F-4 IFT F-5 See Fig. 3-6	Test setup: See Fig. 3-2 and Fig. 3-3. Adjust for maximum meter reading.
2	10.7 MHz without modulation	- ditto -	Rf signal generator frequency	Carefully adjust rf signal generator frequency around 10.7 MHz for maximum meter reading.
3				Repeat steps 1 and 2 two or three times.
4	No input signal (noise only)	- ditto -	core of IFT F-5	Test setup: See Fig. 3-4 and Fig. 3-5. Adjust for "0V DC" meter reading.

3-2. FM I-F ALIGNMENT

Test Equipment/Tools Required

- \* Rf signal generator (FM)
- \* VOM
- \* 8 Ω
- \* Alignment screwdriver
- \* Alligator clip

Preparation:

Rf signal generator modulation: 400 Hz, ± 22.5 kHz FM  
 Rf signal generator output level: Usable lowest possible  
 Band selector: FM  
 VOL control setting: Maximum

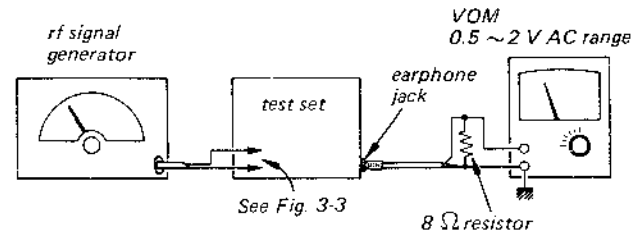

Fig. 3-2. FM i-f alignment frequency coverage and tracking adjustment setup

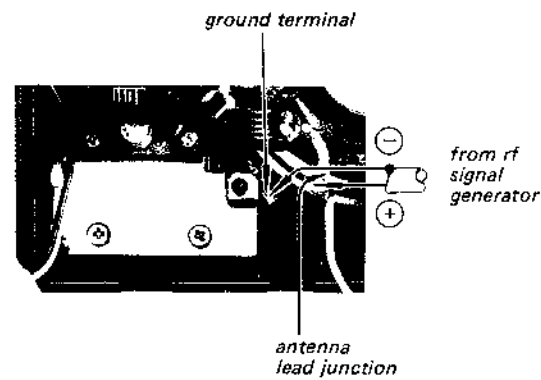

Fig. 3-3. Rf signal generator coupling for FM i-f alignment, frequency coverage and tracking adjustment.

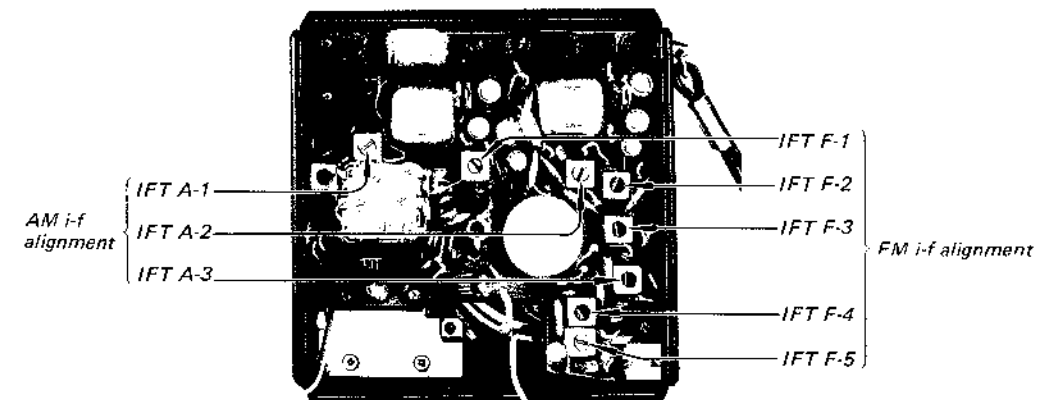

Fig. 3-6. Adjustment locations.

3.3. FREQUENCY COVERAGE AND TRACKING ADJUSTMENT

Adjustment	Rf Signal Generator Coupling	Rf Signal Generator Frequency	Receiver Dial Setting	Adjust	Remarks
AM Frequency Coverage	Loop antenna (See Fig. 3-1.)	520 kHz	Minimum frequency	Core of AM osc coil L6	Rf signal generator modulation: 400 Hz, 30 % AM Rf signal generator output level: Usable lowest possible. VOM connection: See Fig. 3-1. Band selector: AM VOL control setting: Maximum Adjust for maximum meter reading. Repeat adjustment two or three times ending with TC4 and TC3. Fix L5 with wax.
		1,700 kHz	Maximum frequency	AM osc trimmer TC4	
AM Tracking		620 kHz	Tune in 620 kHz signal	Position of AM ant coil L5	
		1,400 kHz	Tune in 1,400 kHz signal	AM ant trimmer TC3	
FM Frequency Coverage	Direct connection (See Fig. 3-2 and Fig. 3-3.)	86.5 MHz	Minimum frequency	Pitch of FM osc coil L4	Rf signal generator modulation: 400 Hz, $\pm 22.5$ kHz FM Rf signal generator output level: Usable lowest possible. VOM connection: See Fig. 3-2. Band selector: FM VOL control setting: Maximum Adjust for maximum meter reading. Repeat adjustment two or three times ending with TC2 and TC1. Fix L2 with wax.
		109.5 MHz	Maximum frequency	FM osc trimmer TC2	
FM Tracking		86.5 MHz	Minimum frequency	Pitch of FM rf coil L2	
		109.5 MHz	Maximum frequency	FM rf trimmer TC1	

Note: When 0.5 ~ 2 V AC range is not available on the VOM, use a VTVM instead of the VOM or use a rectifying circuit with the VOM 0.5 ~ 2 V DC range as shown below.

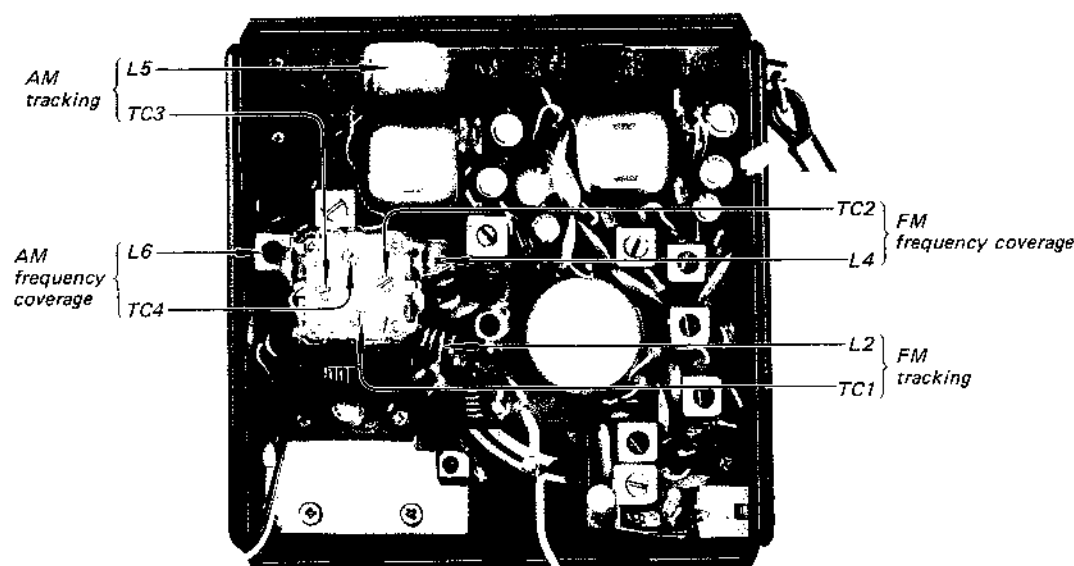
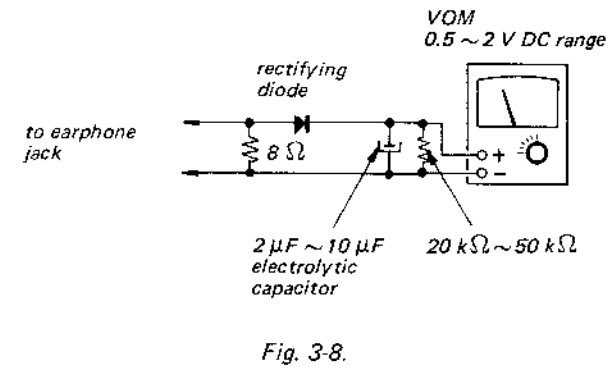
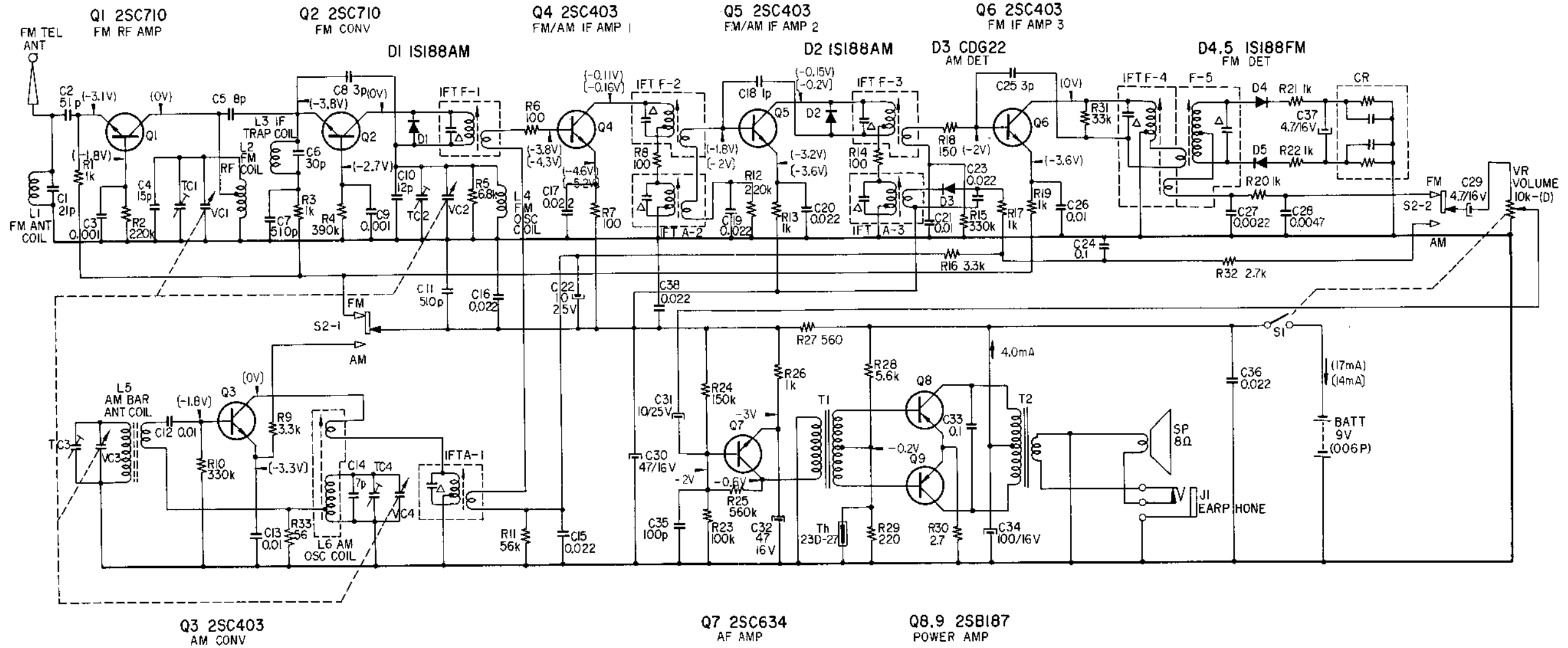

Fig. 3-7. Adjustment locations

SECTION 4

SCHEMATIC AND MOUNTING DIAGRAMS

4-1. SCHEMATIC DIAGRAM



Note: 1. All capacitance values in  $\mu F$  and all resistance values in  $\Omega$  unless otherwise noted.  
 2. All voltages measured with reference to battery positive terminal with a dc voltmeter ( $20\text{ k}\Omega/V$ ) with no signal received. The values in ( ) are measured with band selector set to FM and in [ ] with AM, others are

common. Variations may be noted due to normal production tolerances.  
 3. All currents measured with a dc ammeter with no signal received.  
 4. Capacitor marked with  $\Delta$  is built in i-f transformer.

Fig. 4-1.

**TFM-3750 W TFM-3750 W**

**4-2. MOUNTING DIAGRAM**  
— Conductor Side —

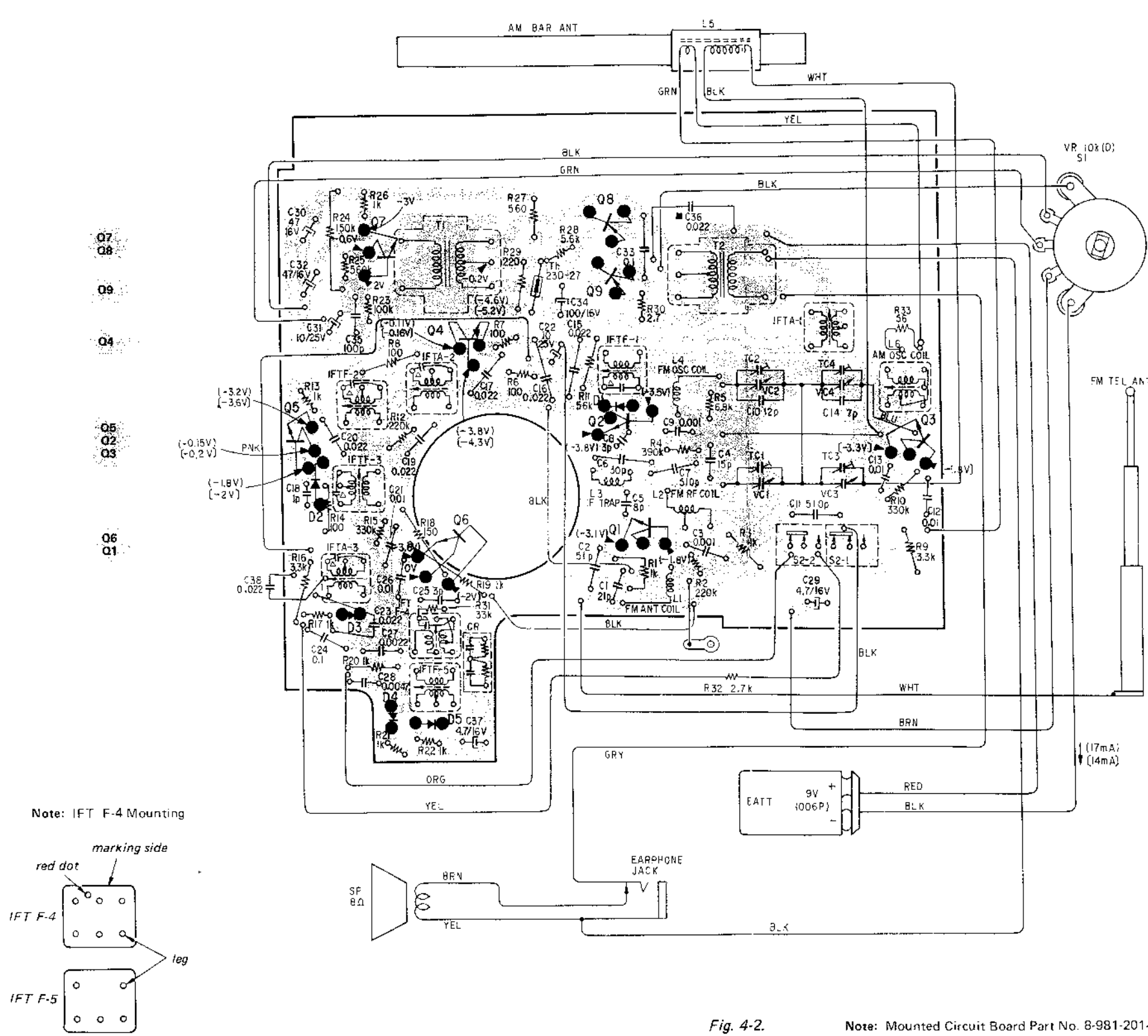
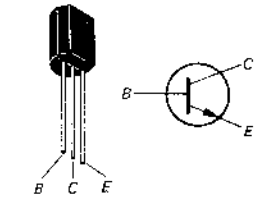
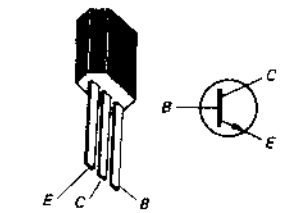

Fig. 4-2. Note: Mounted Circuit Board Part No. 8-981-201-90

Q1, Q2 : 2SC710



Q3 thru Q6 : 2SC403  
Q7 : 2SC634



Q8, Q9 : 2SB187

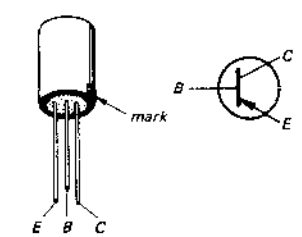

D1, D2 : 1S188 AM  
D3 : CDG-22  
D4, D5 : 1S188 FM

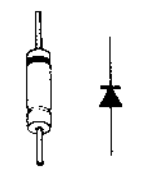

SECTION 5  
EXPLODED VIEW AND PACKING

5-1. EXPLODED VIEW

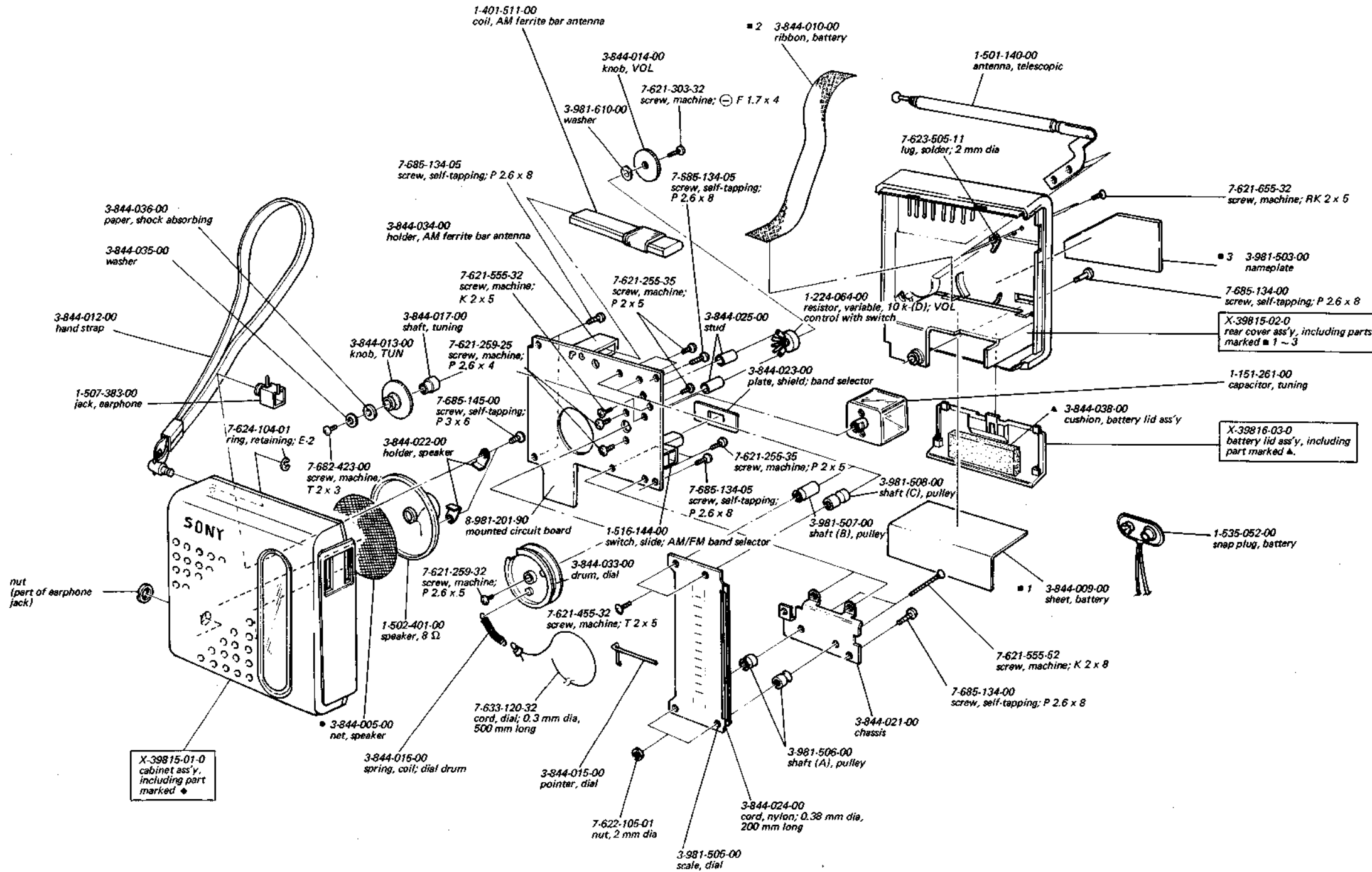
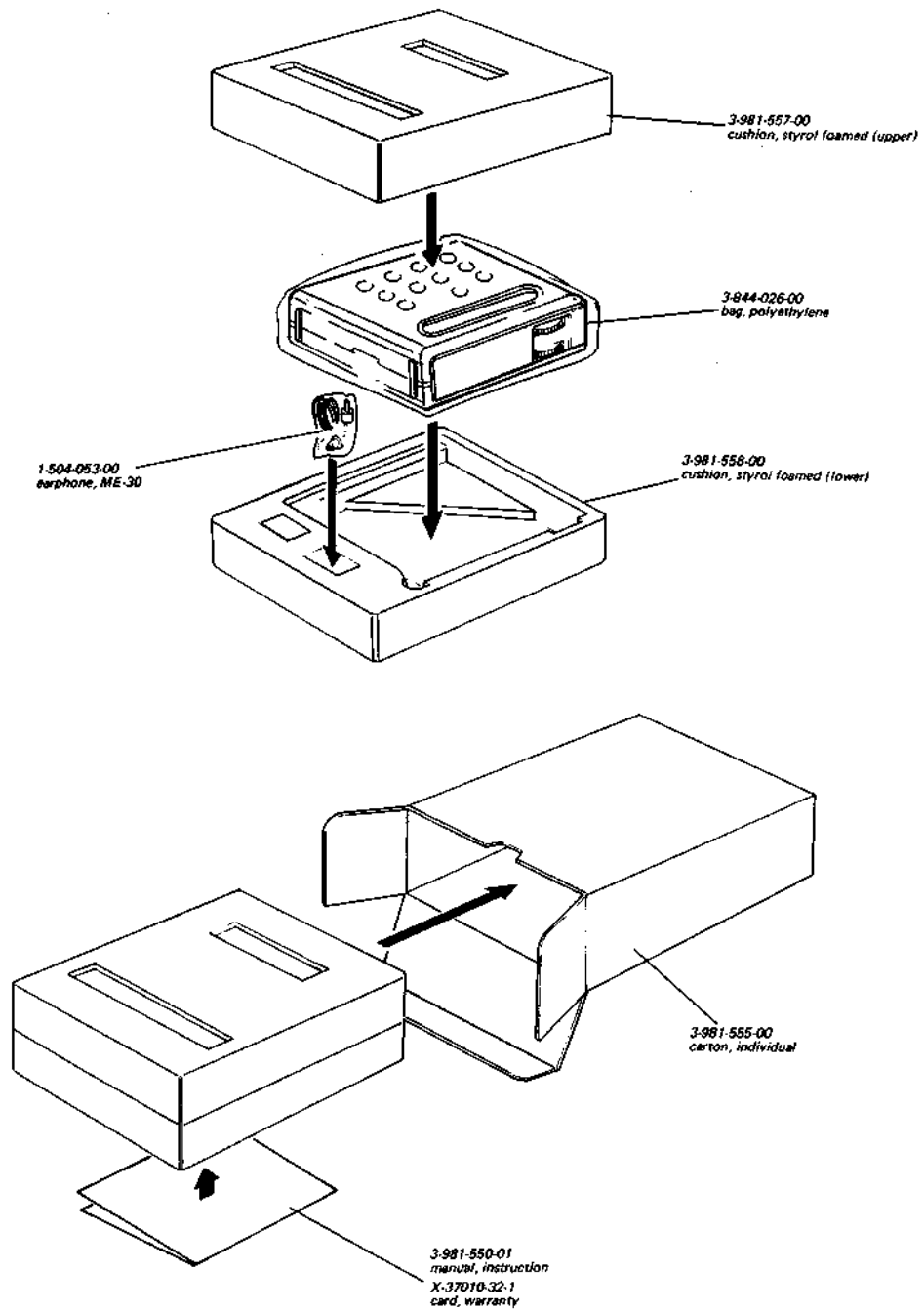

Fig. 5-1.



**5-2. PACKING**



**Fig. 5-2.**

**SECTION 6  
ELECTRICAL PARTS LIST**

<u>Ref. No.</u>	<u>Part No.</u>	<u>Description</u>	
<b>MOUNTED CIRCUIT BOARD</b>			
	8-981-201-90	mounted circuit board	
<b>SEMICONDUCTORS</b>			
Q1		transistor	2SC710
Q2		transistor	2SC710
Q3		transistor	2SC403
Q4		transistor	2SC403
Q5		transistor	2SC403
Q6		transistor	2SC403
Q7		transistor	2SC634
Q8		transistor	2SB187
Q9		transistor	2SB187
D1		diode	1S188AM
D2		diode	1S188AM
D3		diode	CDG-22
D4		diode	1S188FM
D5		diode	1S188FM
Th	1-800-213-00	thermistor	23D-27
<b>COILS AND TRANSFORMERS</b>			
L1	1-405-530-00	coil, FM antenna	
L2	1-405-548-00	coil, FM rf	
L3	1-405-544-00	coil, if trap	
L4	1-405-536-00	coil, FM oscillator	
L5	1-401-511-00	coil, AM ferrite bar antenna	
L6	1-405-526-00	coil, AM oscillator	
IFT A-1	1-403-879-00	transformer, AM i-f	
IFT A-2	1-403-878-00	transformer, AM i-f	
IFT A-3	1-403-877-00	transformer, AM i-f	
IFT F-1	1-403-880-00	transformer, FM i-f	
IFT F-2	1-403-881-00	transformer, FM i-f	
IFT F-3	1-403-881-00	transformer, FM i-f	
IFT F-4	1-403-882-00	transformer, FM i-f	
IFT F-5	1-403-883-00	transformer, FM i-f	
T1	1-423-180-00	transformer, driver	
T2	1-427-337-00	transformer, output	
<b>CAPACITORS</b>			
All fixed capacitors are ceramic type expressed in $\mu\text{F}$ except as indicated with p, which means $\mu\text{mF}$ .			
C1	1-102-958-11	21 p	
C2	1-101-882-11	51 p	
C3	1-101-455-11	0.001	
C4	1-102-956-11	15 p	
C5	1-102-810-11	8 p	

<u>Ref. No.</u>	<u>Part No.</u>	<u>Description</u>	
C6	1-102-962-11	30 p	
C7	1-101-059-11	510 p	
C8	1-101-953-11	3 p	
C9	1-101-455-11	0.001	
C10	1-101-962-11	12 p	
C11	1-101-059-11	510 p	
C12	1-101-923-11	0.01	
C13	1-101-923-11	0.01	
C14	1-101-957-11	7 p	
C15	1-101-924-11	0.022	
C16	1-101-924-11	0.022	
C17	1-101-924-11	0.022	
C18	1-101-951-11	1 p	
C19	1-101-924-11	0.022	
C20	1-101-924-11	0.022	
C21	1-101-924-11	0.01	
C22	1-121-398-11	10	25 V electrolytic
C23	1-105-837-12	0.022	mylar
C24	1-105-685-12	0.1	mylar
C25	1-101-953-11	3 p	
C26	1-101-923-11	0.01	
C27	1-102-100-11	0.0022	
C28	1-102-102-11	0.0047	
C29	1-121-394-11	4.7	16 V electrolytic
C30	1-121-409-11	47	16 V electrolytic
C31	1-121-398-11	10	25 V electrolytic
C32	1-121-409-11	47	16 V electrolytic
C33	1-105-685-12	0.1	mylar
C34	1-121-415-11	100	16 V electrolytic
C35	1-101-963-11	100 p	
C36	1-101-924-11	0.022	
C37	1-121-394-11	4.7	16 V electrolytic
C38	1-101-924-11	0.022	
CR	1-102-254-00	encapsulated component	
(TC1-TC4 VC1-VC4)	1-151-251-00	capacitor, tuning	
<b>RESISTORS</b>			
All fixed resistors are in $\Omega$ , $\pm 5\%$ , $\frac{1}{4}$ W carbon film type unless otherwise specified.			
R1	1-242-673-11	1 k	
R2	1-242-729-11	220 k	
R3	1-242-673-11	1 k	
R4	1-242-735-11	390 k	
R5	1-242-693-11	6.8 k	
R6	1-242-649-11	100	
R7	1-242-649-11	100	
R8	1-242-649-11	100	
R9	1-242-685-11	3.3 k	
R10	1-242-733-11	330 k	

<u>Ref. No.</u>	<u>Part No.</u>	<u>Description</u>
R11	1-242-715-11	56 k
R12	1-242-729-11	220 k
R13	1-242-673-11	1 k
R14	1-242-649-11	100
R15	1-242-733-11	330 k
R16	1-242-685-11	3.3 k
R17	1-242-673-11	1 k
R18	1-242-653-11	150
R19	1-242-673-11	1 k
R20	1-242-673-11	1 k
R21	1-242-673-11	1 k
R22	1-242-673-11	1 k
R23	1-242-721-11	100 k
R24	1-242-725-11	150 k
R25	1-242-739-11	560 k
R26	1-242-673-11	1 k
R27	1-242-667-11	560

<u>Ref. No.</u>	<u>Part No.</u>	<u>Description</u>
R28	1-242-691-11	5.6 k
R29	1-242-657-11	220
R30	1-242-611-11	2.7
R31	1-242-709-11	33 k
R32	1-242-683-11	2.7 k
R33	1-202-343-11	56
VR	1-224-064-00	10 k-(D), variable; VOL control with switch

**MISCELLANEOUS**

TEL ANT	1-501-140-00	antenna, telescopic
SP	1-502-401-00	speaker, 8 $\Omega$
S2	1-516-144-00	switch, slide; AM/FM band selector
J1	1-507-383-00	jack, earphone
	1-535-052-00	snap plug, battery