

TFM-1000W



Specifications

Circuit:	14 Transistor Superheterodyne
Frequency Coverage:	FM 86.5~108 Mc (3.53~2.73 m) MW 530~1,605 Kc (566~187 m) SW ₁ 1.6~4.5 Mc (187.5~66.5 m) SW ₂ 4.7~12 Mc (63.8~25 m)
Antenna System:	FM SW Built-in Telescopic Antenna MW Built-in Ferrite Bar Antenna Jack for Wire Antenna
Intermediate Frequency:	FM 10.7 Mc, AM 455 Kc
Maximum Sensitivity: (at 10 mW output)	FM 0.95 μ V, MW 27 μ V/m SW ₁ 1.8 μ V, SW ₂ 1.6 μ V
Selectivity:	31 dB at 10 Kc off resonance, at 1,400 Kc
Output Power:	820 mW (undistorted) 1.3 W (maximum)
Current Drain:	26 mA (FM/AM) at zero signal, 250 mA at 820 mW output
Speaker:	10 \times 15 cm (4 \times 6") PM dynamic, 8 Ω
Power Source:	Four "D" Size Flashlight Batteries, 6V in total or House Current by using SONY AC Power Adaptor
Dimensions:	218(H) \times 264(W) \times 103(D) mm (8-9/16 \times 10-3/8 \times 4-1/16")
Weight:	2.54 Kgs. (5.6 lbs) with Batteries

SONY[®]
SERVICING GUIDE

Removal of Chassis

- (1) Remove the two Back Cover Holding Screws and open the Back Cover. Take out all the Batteries.
- (2) Remove the Tuning, Fine Tuning, Band Setting, Volume Control, and Tone Control Knobs by pulling them out.
- (3) Push the Local, AFC, and Power Switch Buttons.
- (4) Remove the five Nuts marked with \triangle shown in Fig. 1 and 2.
- (5) Unsolder the five leads marked with \blacktriangle shown in Fig. 2.
- (6) Unsolder the Blue leads at the Volume Control coming from the AUX in Jack.
- (7) Remove the Chassis from the Cabinet gently taking care not to cut the leads.

Removal of CP Circuit Board

- (1) Remove the four Screws marked with \odot shown in Fig. 2.
- (2) Unsolder all the leads on the CP Circuit Board coming from the IF Circuit Board, MW Ferrite Bar Antenna Coil, and FM Tuner.
- (3) Remove the CP Circuit Board from the Chassis gently taking care not to cut the leads.

Removal of FM Tuner Circuit Board (FMC-6AW)

- (1) Remove the CP Circuit Board.
- (2) Unsolder all the leads at the FM Tuner and AM Tuning Capacitor.
- (3) Remove the four Sub-Chassis Holding Screws. (Two of them are marked with \bullet in Fig. 2).
- (4) Remove the Sub-Chassis from the Chassis gently taking care not to cut the Dial Cord.
- (5) Remove the Tuner Gear Holding Screw at the FM Tuning Capacitor.
- (6) Remove the Tuner Gear at the FM Tuning Capacitor.
- (7) Remove the four FM Tuner (FMC-6AW) Holding Screws. The FM Tuner (FMC 6AW) can now be removed.

Removal of IF Circuit Board

- (1) Unsolder the IF Shield Case Cover, FM-AM Select Switch Plate and Coaxial Cable marked with \blacksquare shown in Fig. 2.
- (2) Take out the FM-AM Select Switch Plate marked with \star shown in Fig. 2.
- (3) Remove the two FM-AM Select Switch Bracket Holding Screws.
- (4) Remove the three Screws marked with \sqcap shown in Fig. 2.
- (5) Remove the IF Circuit Board from Chassis gently taking care not to cut the leads.

Removal of AF Circuit Board

- (1) Remove the two Screws marked with \square shown in Fig. 2.
- (2) Unsolder the four leads on the AF Circuit Board marked with \cdot shown in Fig. 2.

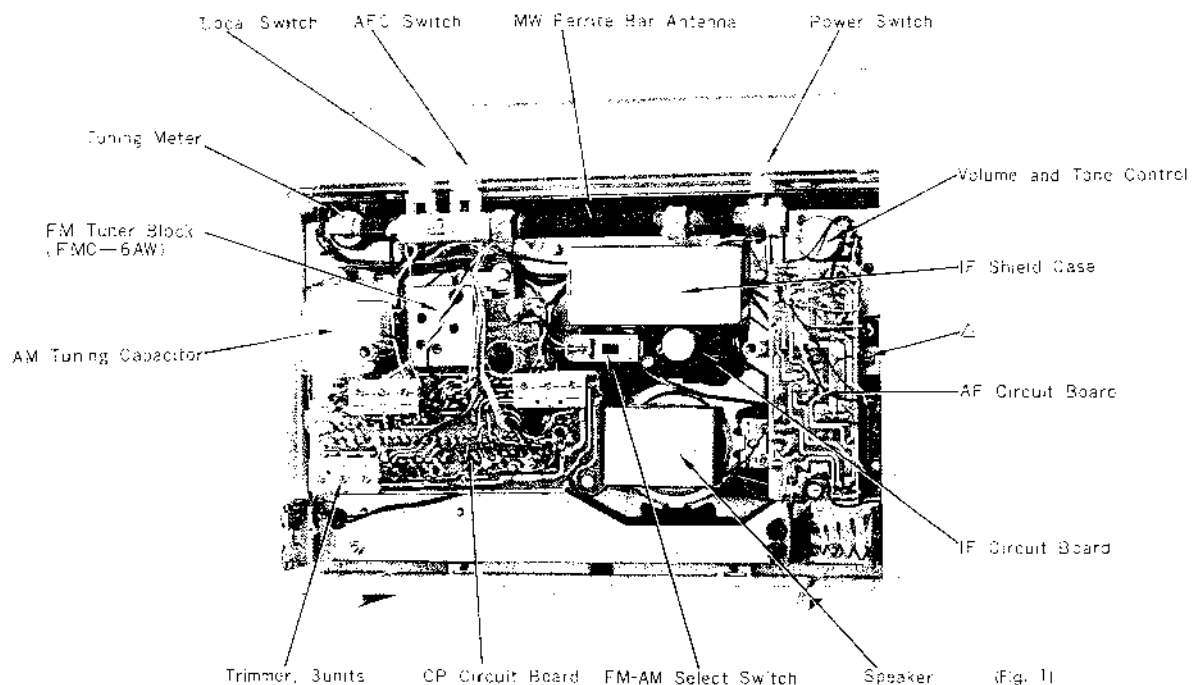

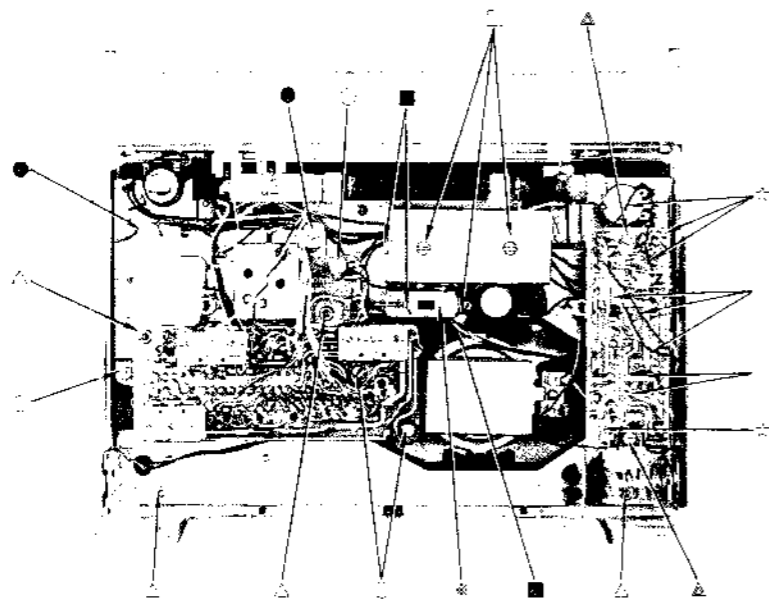

(Fig. 2)

Block Diagram

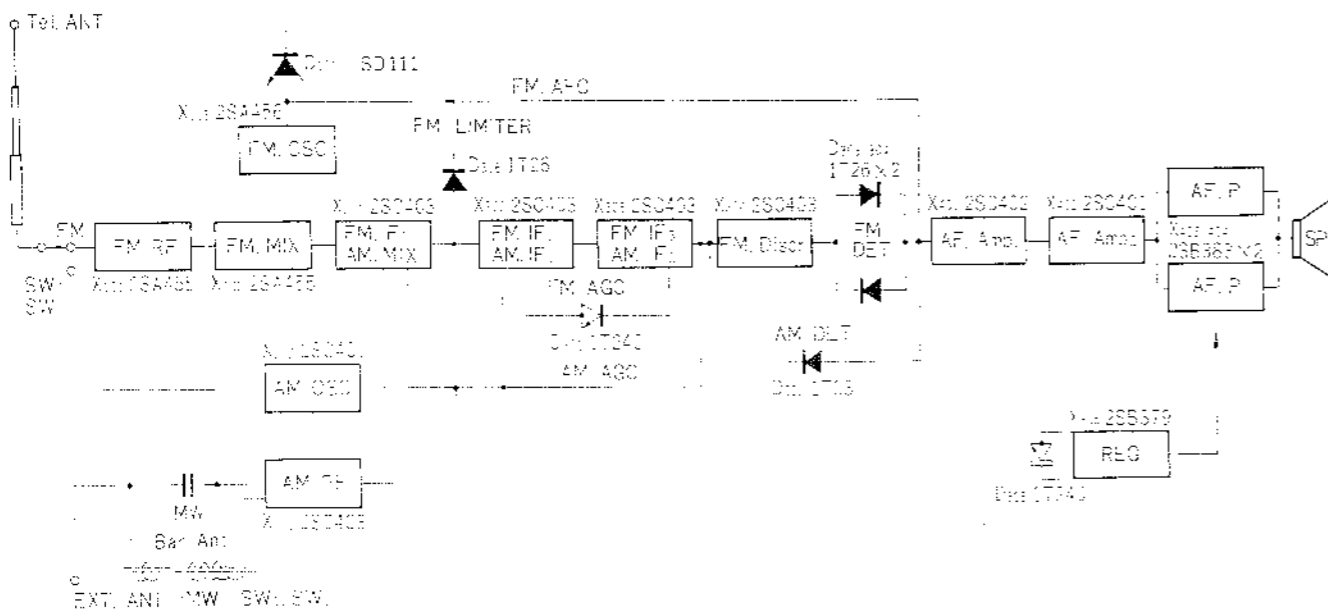

To String the Dial Cord

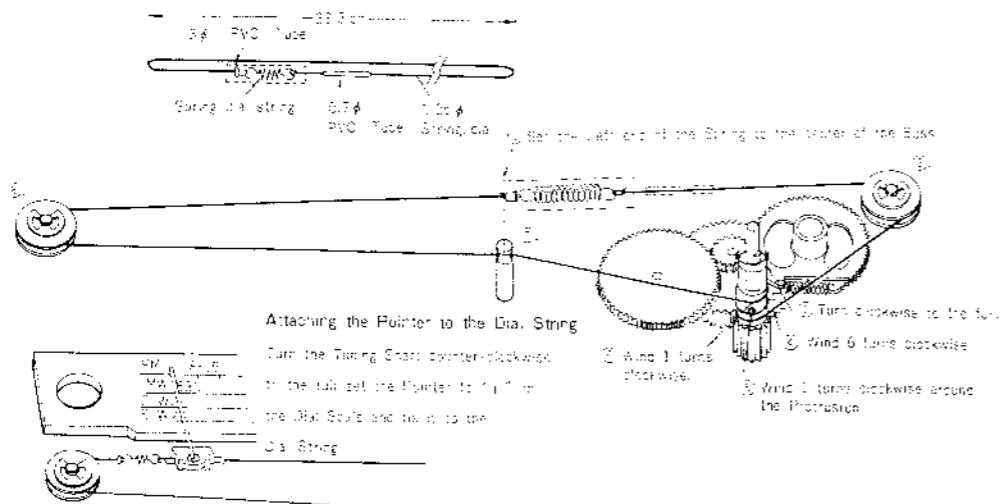

Frequency Coverage and Tracking Adjustment

Adj. Item	SSG (Standard Signal Generator) Coupling	SSG Freq.	Receiving Dial Setting	Connect VTVM	Adjust	Remarks
FM Frequency Coverage	 *Unnecessary the Dummy Antenna. Connect the SSG to the Antenna terminal (marked with RED on the CP Circuit Board) and ground.	85.5Mc (400 c/s ± 22.5 Kc FM MOD.)	Fully Left	Across 8Ω Load Resistor	FM OSC Coil (L ₁₀₂)	Adjust for maximum deflection. Fine Tuning: Set the slit mark on the Fine Tuning Knob in the vertical direction Volume: Max. Tone: High Local: OFF AFC: OFF Power supply: DC 6V
		109.5 Mc (")	Fully Right		FM OSC Trimmer (C _{T102})	
FM Tracking	—ditto—	85.5 Mc (")	Tune to 85.5 Mc Signal	—ditto—	FM RF Coil (L ₁₀₂)	—ditto—
		109.5 Mc (")	Tune to 109.5Mc Signal	—ditto—	FM RF Trimmer (C _{T101})	—ditto—
SW ₁ Frequency Coverage	 Connect the SSG to the Antenna terminal (marked with RED on the CP Circuit Board) and ground of the set through the Dummy Antenna.	1.55 Mc (1000 c/s 30% AM MOD)	Fully Left	—ditto—	SW ₁ OSC Coil (L ₂₀₃)	—ditto—
		4.7 Mc (")	Fully Right		SW ₁ OSC Trimmer (C _{T203})	
SW ₁ Tracking	—ditto—	1.55 Mc (")	Tune to 1.55Mc Signal	—ditto—	SW ₁ ANT Coil (L ₂₀₁) SW ₁ RF Coil (L ₂₀₂)	—ditto—
		4.7 Mc (")	Tune to 4.7 Mc Signal	—ditto—	SW ₁ ANT Trimmer (C _{T201}) SW ₁ RF Trimmer (C _{T202})	
SW ₂ Frequency Coverage	ditto—	4.6 Mc (1000 c/s 30% AM MOD)	Fully Left	—ditto—	SW ₂ OSC Coil (L ₂₀₄)	—ditto—
		12.6 Mc (")	Fully Right		SW ₂ OSC Trimmer (C _{T204})	
SW ₂ Tracking	—ditto—	4.6 Mc (")	Tune to 4.6 Mc Signal	—ditto—	SW ₂ ANT Coil (L ₂₀₁) SW ₂ RF Coil (L ₂₀₂)	—ditto—
		12.6 Mc (")	Tune to 12.6 Mc Signal	—ditto—	SW ₂ ANT Trimmer (C _{T201}) SW ₂ RF Trimmer (C _{T202})	
MW Frequency Coverage	Loop Antenna	520 Kc (")	Fully Left	—ditto—	MW OSC Coil (L ₂₀₇)	—ditto—
		1680 Kc (")	Fully Right		MW OSC Trimmer (C _{T207})	
MW Tracking	—ditto—	620 Kc (")	Tune to 620Kc Signal	—ditto—	MW ANT Coil (L ₂₀₁) MW RF Coil (L ₂₀₂)	—ditto—
		1,400 Kc (")	Tune to 1,400Kc Signal	—ditto—	MW ANT Trimmer (C _{T201}) MW RF Trimmer (C _{T202})	

Circuit Schematic

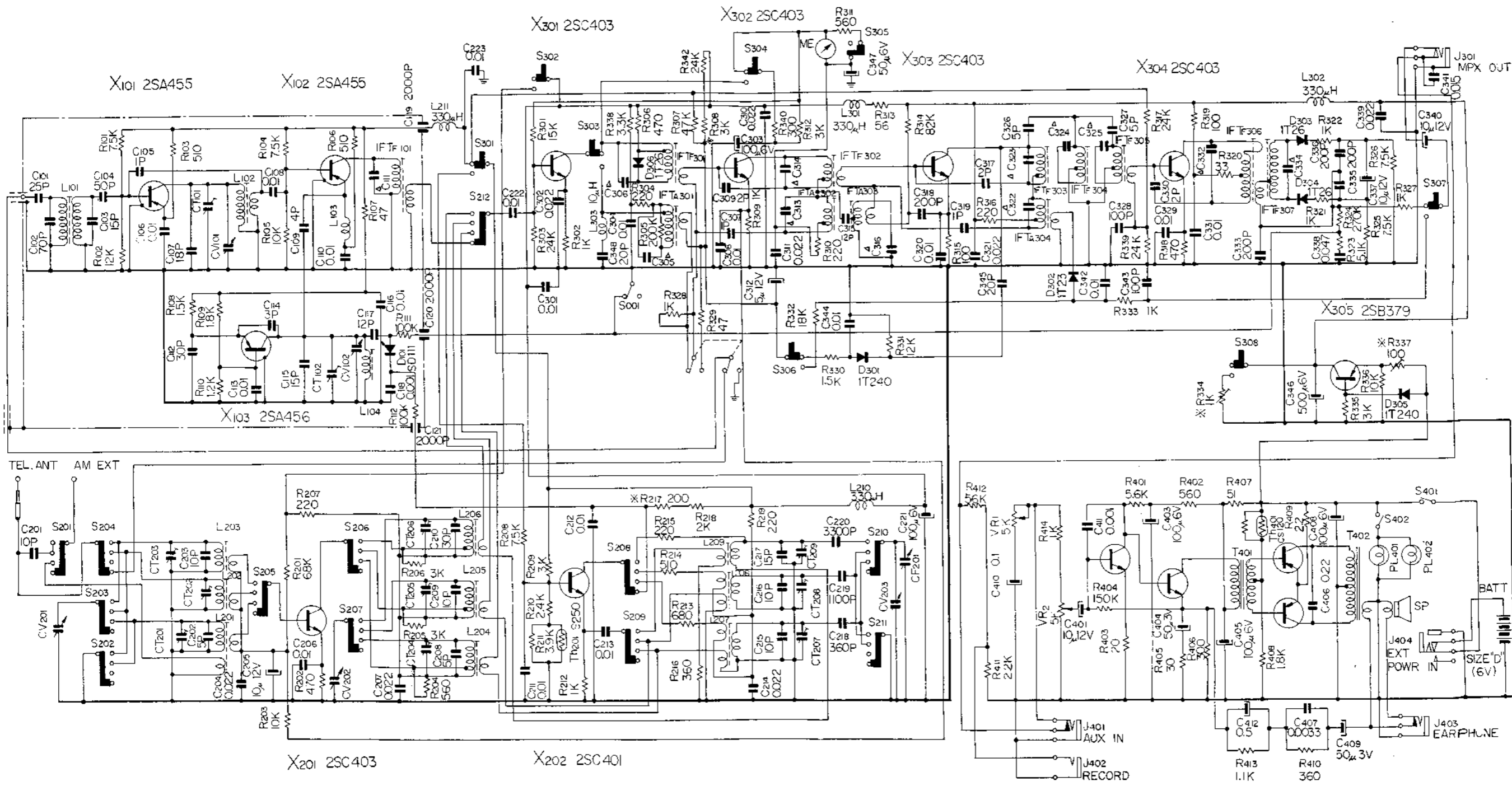

* To be Adjusted
 Capacitors marked with "Δ" are built in relative IF Transformers

X401 2SC402 X402 2SC401 X403.404 2SB383x2

Mounting Details

FM Tuner Section (FMC-6AW)

— Printed Side —

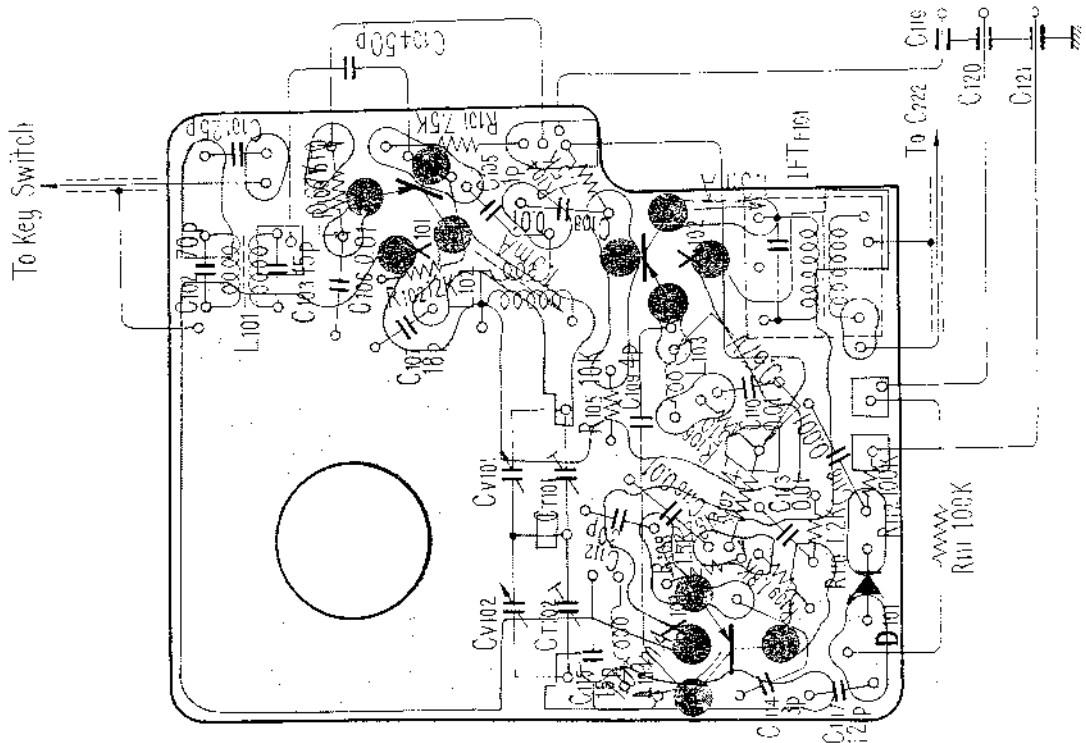

— Parts Side —

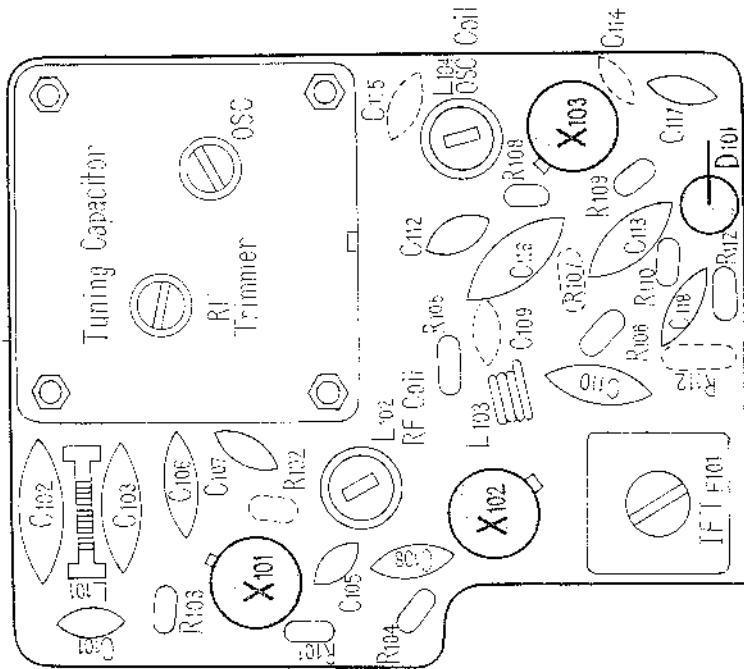

Mounting Diagram

AM Coil Pack Section

—Printed Side—

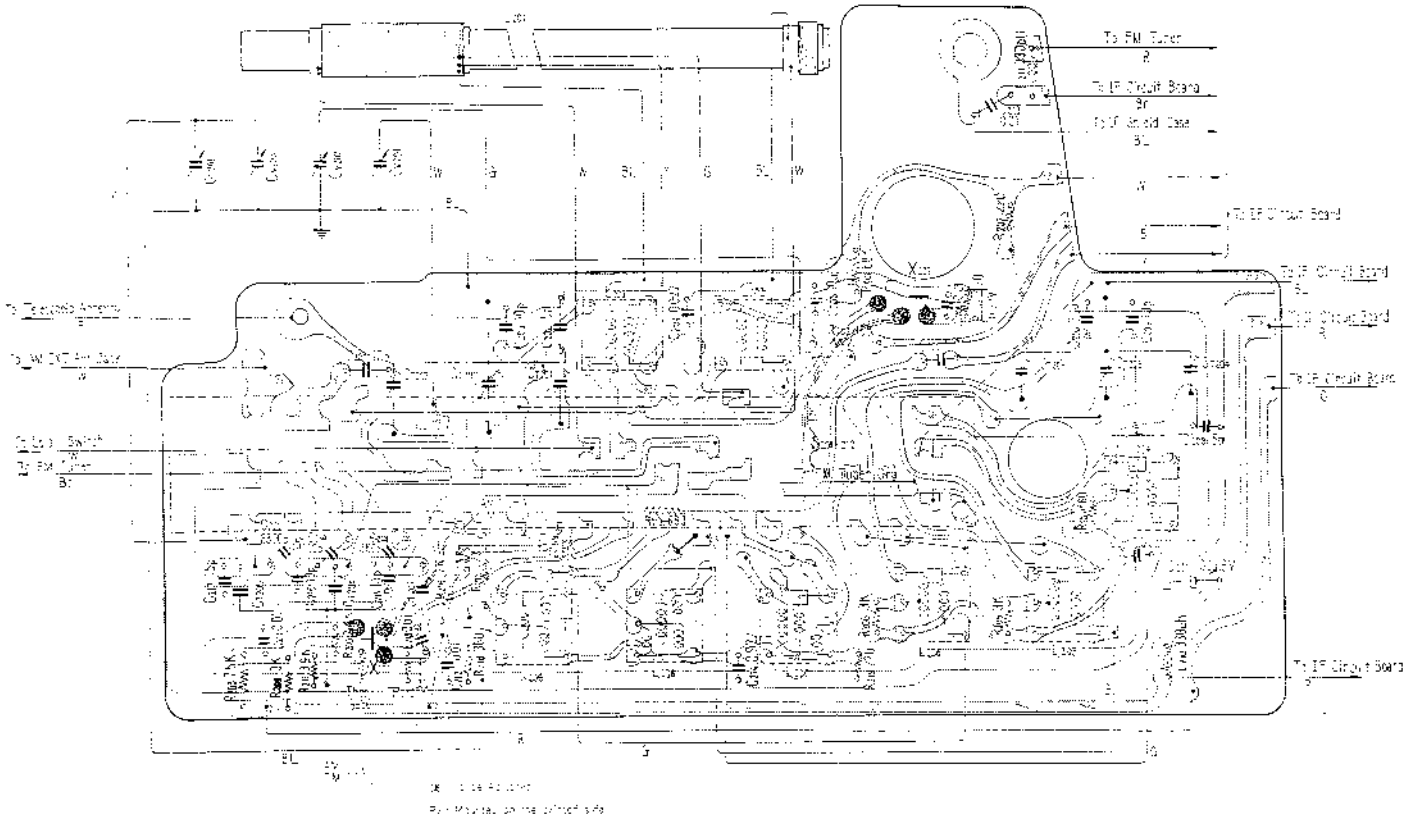

—Parts Side—

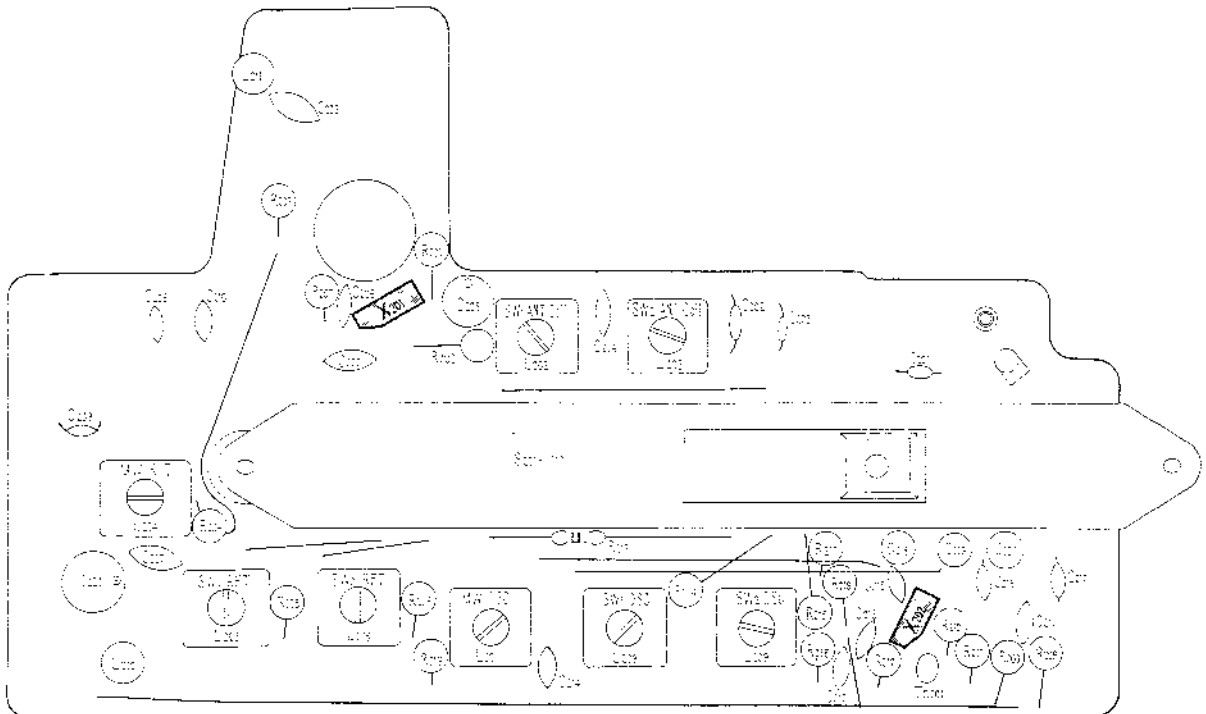

Mounting Diagram

IF Section

—Printed Side—

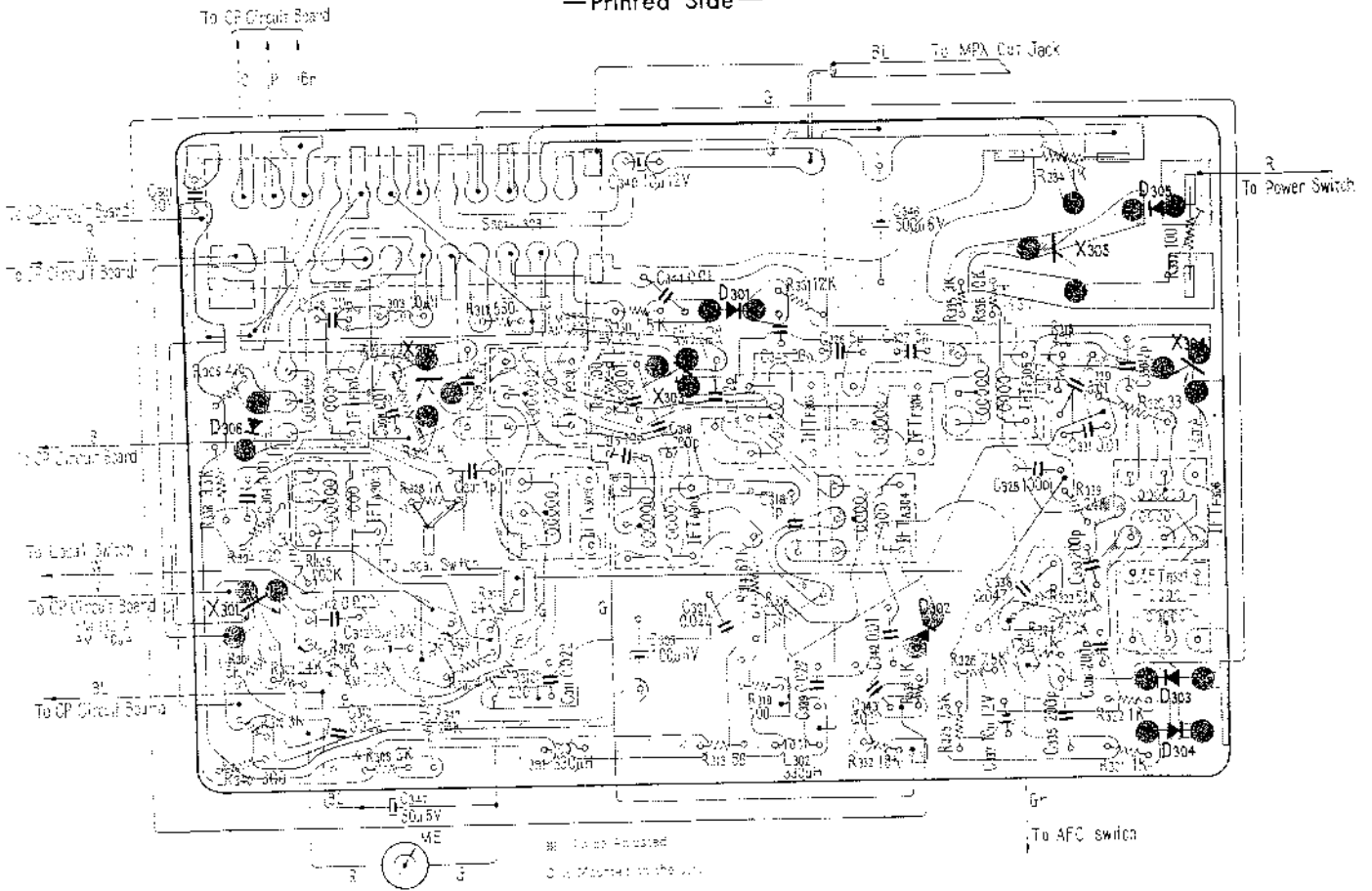

—Parts Side—

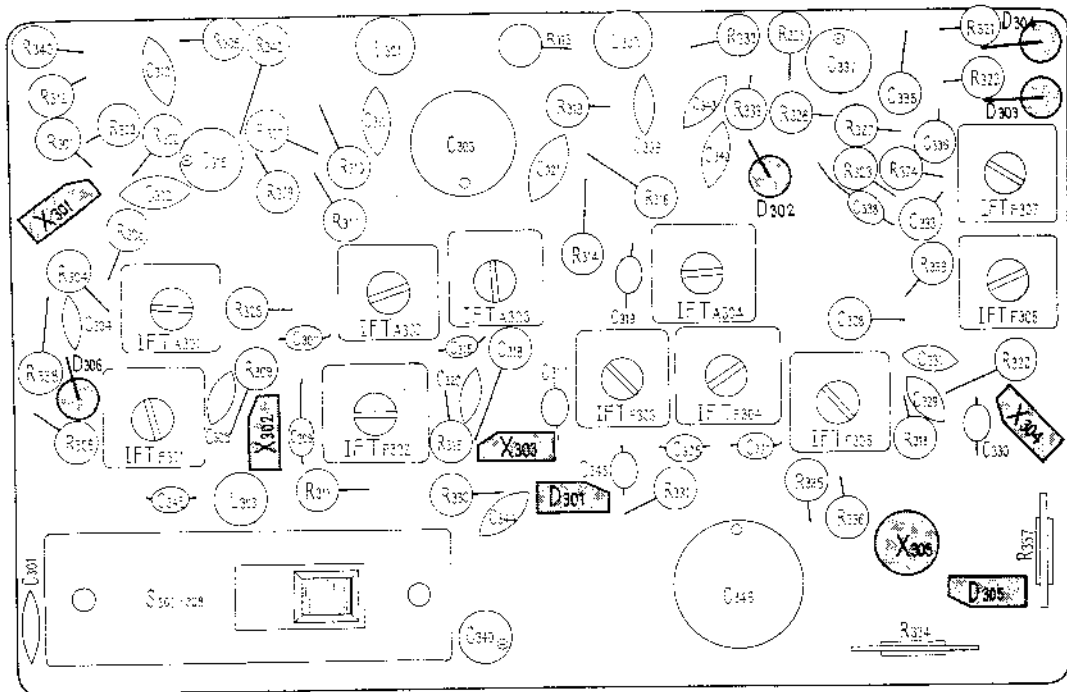

Mounting Diagram

AF Section (AF.1A)

— Printed Side —

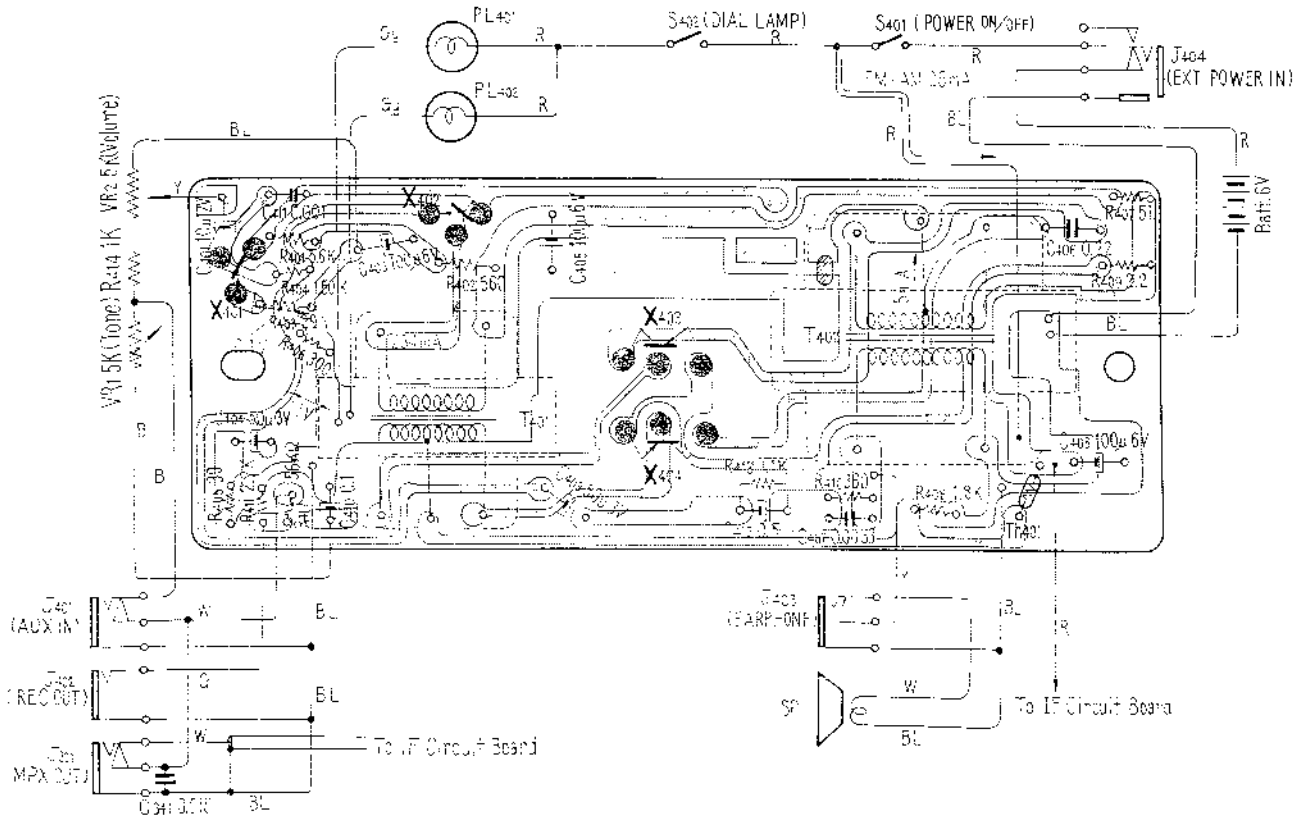

— Parts Side —

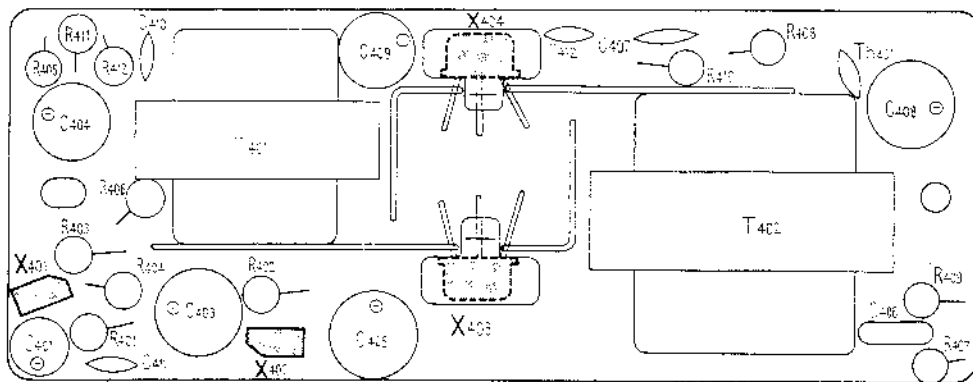

Parts Mounted on the printed side.

Exploded Diagram

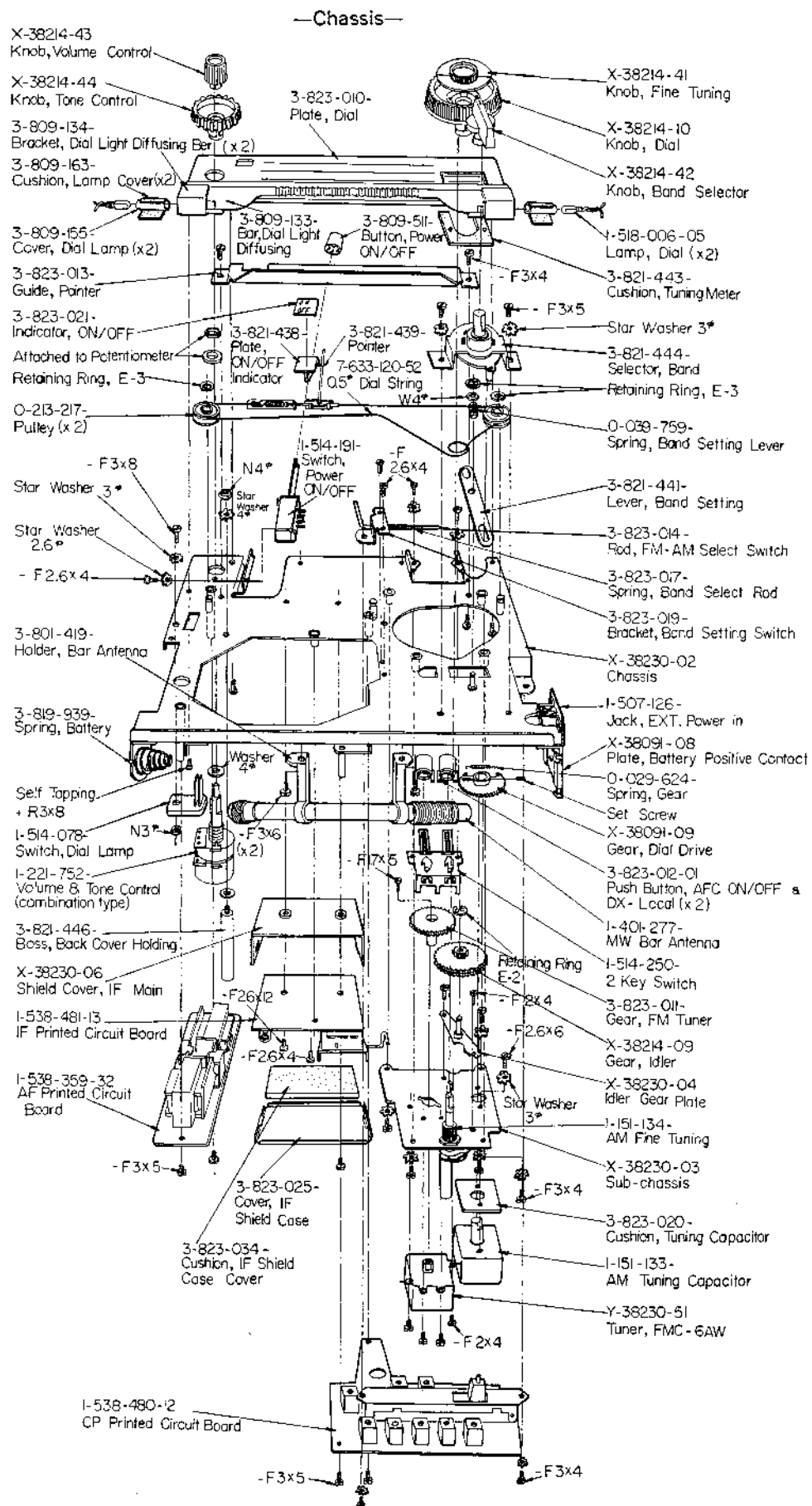

Exploded Diagram

--Cabinet--

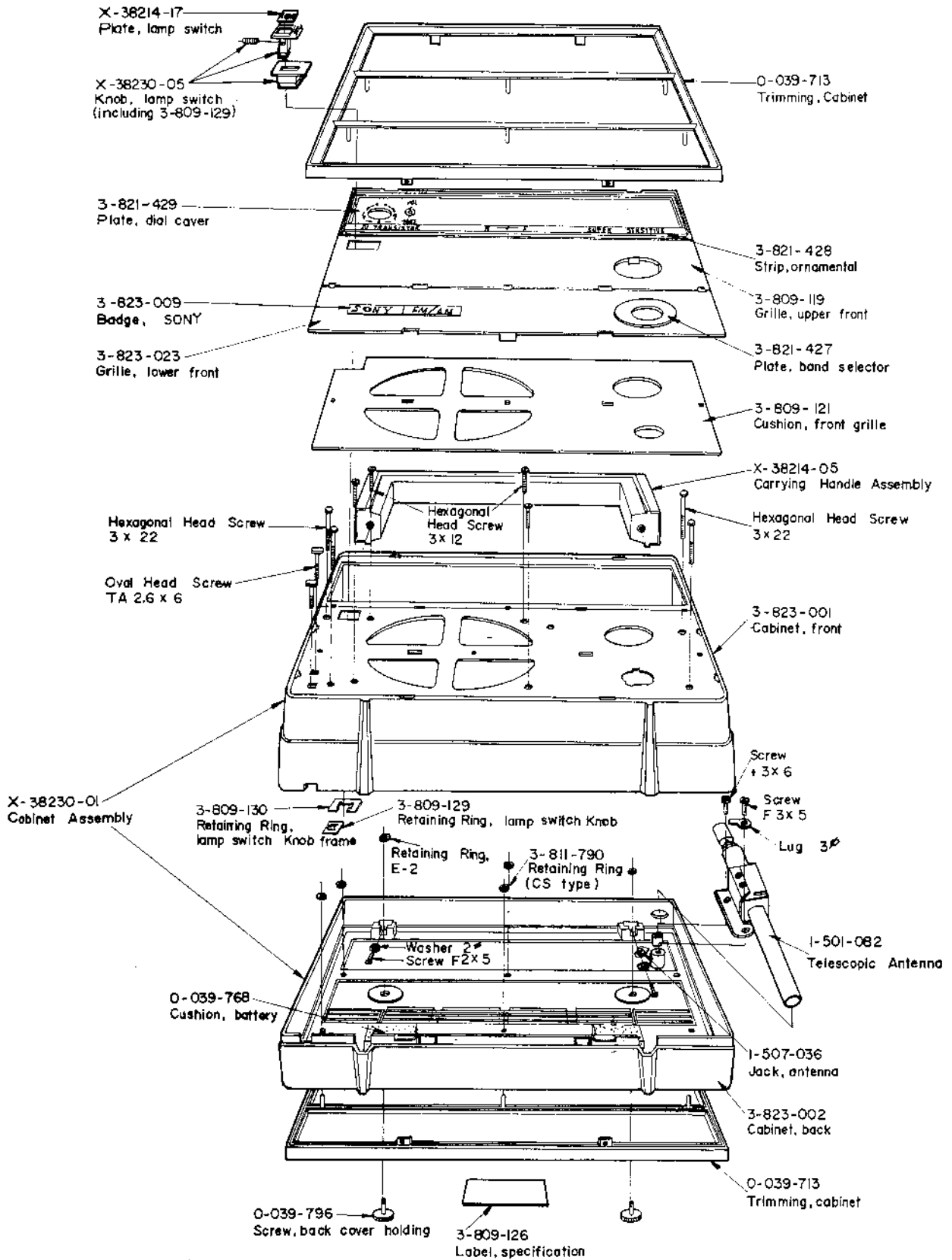

Electrical Parts List

Part No.	Symbol	Description	Part No.	Symbol	Description
1-501-082-11	Tel. ANT	Antenna, telescopic		D ₃₀₁	Diode 1T240
1-401-216-11	L ₁₀₁	Coil, FM antenna		D ₃₀₂	" 1T23
1-425-162-11	L ₁₀₂	" FM RF		D ₃₀₃	" 1T26
1-405-282-11	L ₁₀₃	" Injection		D ₃₀₄	" 1T26
-135-11	L ₁₀₄	" FM oscillator		D ₃₀₅	" 1T240
1-401-277-13	L ₂₀₁	" MW ferrite bar antenna		D ₃₀₆	" 1T26
-286-11	L ₂₀₂	" SW ₁ antenna	8-690-004-00	Th ₂₀₁	Thermistor S250
-287-11	L ₂₀₃	" SW ₂ "	8-691-001-01	Th ₄₀₁	" CS120
1-425-232-11	L ₃₀₄	" MW RF			Resistor
-272-11	L ₂₀₅	" SW ₁ "	1-221-752-11	VR ₁	5KΩ Tone Control
-273-11	L ₂₀₆	" SW ₂ "		VR ₂	5KΩ Volume Control
1-405-275-11	L ₂₀₇	" MW oscillator	1-208-054-11	R ₁₀₁	7.5KΩ 1/10W Ceramic
-289-12	L ₂₀₈	" SW ₁ "	-059-11	R ₁₀₂	12KΩ " "
-290-11	L ₂₀₉	" SW ₂ "	-026-11	R ₁₀₃	510Ω " "
1-407-050-11	L ₂₁₀	Inductor, micro 330μF	-054-11	R ₁₀₄	7.5KΩ " "
-050-11	L ₂₁₁	" 330μF	-057-11	R ₁₀₅	10KΩ " "
-050-11	L ₃₀₁	" 330μF	-026-11	R ₁₀₆	510Ω " "
-050-11	L ₃₀₂	" 330μF	-105-11	R ₁₀₇	47Ω " "
-082-11	L ₃₀₃	" 10μF	-037-11	R ₁₀₈	1.5KΩ " "
			-039-11	R ₁₀₉	1.8KΩ " "
1-403-231-11	IFT _{F101}	Transformer, FM IF signal tuned	-035-11	R ₁₁₀	1.2KΩ " "
-243-15	IFT _{F301}	" "	1-201-868-11	R ₁₁₁	100KΩ 1/8W Composition
-244-15	IFT _{F302}	" "	1-208-145-11	R ₁₁₂	100KΩ 1/10W Ceramic
-244-15	IFT _{F303}	" "	1-240-517-11	R ₂₀₁	68KΩ 1/8W Carbon
-244-15	IFT _{F304}	" "	-465-11	R ₂₀₂	470Ω " "
-244-15	IFT _{F305}	" "	-497-11	R ₂₀₃	10KΩ " "
-272-15	IFT _{F306}	Discriminator (primary)	-467-31	R ₂₀₄	560Ω " "
-273-15	IFT _{F307}	" (secondary)	-484-31	R ₂₀₅	3KΩ " "
-026-15	IFT _{A301}	Transformer, AM IF single tuned	-484-31	R ₂₀₆	3KΩ " "
-110-15	IFT _{A302}	" "	-457-31	R ₃₀₇	220Ω " "
-026-15	IFT _{A303}	" "	-494-11	R ₃₀₈	7.5KΩ " "
-110-15	IFT _{A304}	" "	-464-11	R ₃₀₉	3KΩ " "
1-423-100-11	T ₄₀₁	" driver	-482-11	R ₂₁₀	2.4KΩ " "
1-427-088-11	T ₄₀₂	" output	-487-11	R ₂₁₁	3.9KΩ " "
			-473-11	R ₂₁₂	1KΩ " "
1-507-011-11	J ₃₀₁	Jack, MPX out	1-244-469-11	R ₂₁₃	680Ω " "
-011-11	J ₄₀₁	" AUX in	-466-11	R ₂₁₄	510Ω " "
-011-11	J ₄₀₂	" REC. out	-457-11	R ₂₁₅	220Ω " "
-011-11	J ₄₀₃	" Earphone	1-240-462-11	R ₂₁₆	360Ω " "
-126-11	J ₄₀₄	" EXT power in	-456-11	*R ₂₁₇	200Ω " "
-036-11	EXT ANT	" AM EXT ANT	-480-11	R ₂₁₈	2KΩ " "
			-457-31	R ₂₁₉	220Ω " "
1-514-250-12	S ₀₀₁	Switch, AFC ON-OFF	-501-11	R ₃₀₁	15KΩ " "
	S ₀₀₂	" AM DX/Local	-473-11	R ₃₀₂	1KΩ " "
	S ₀₀₃	" FM "	-506-11	R ₃₀₃	24KΩ " "
1-513-314-11	S ₂₀₁₋₂₁₂	" AM band setting	-457-11	R ₃₀₄	220Ω " "
-275-11	S ₃₀₁₋₃₀₄	" FM "	-528-31	R ₃₀₅	200KΩ " "
1-514-191-02	S ₁₀₁	" power ON-OFF	-465-31	R ₃₀₆	470Ω " "
-078-00	S ₄₀₂	" dial lamp	-513-11	R ₃₀₇	47KΩ " "
1-520-058-11	ME	Meter, tuning	-484-11	*R ₃₀₈	3KΩ " "
1-502-069-21	SP	Speaker, 8Ω	-473-11	R ₃₀₉	1KΩ " "
	PL ₄₀₁	Lamp, dial	-457-11	R ₃₁₀	220Ω " "
1-518-006-02	PL ₄₀₂	" "	-467-11	R ₃₁₁	560Ω " "
1-528-001-01	Batt	Battery, 6V in total	-484-11	R ₃₁₂	3KΩ " "
			-443-31	R ₃₁₃	56Ω " "
	X ₁₀₁	Transistor 2SA455	-519-11	R ₃₁₄	82KΩ " "
	X ₁₀₂	" 2SA455	-449-11	R ₃₁₅	100Ω " "
	X ₁₀₃	" 2SA456	-457-31	R ₃₁₆	220Ω " "
	X ₂₀₁	" 2SC403	-506-11	R ₃₁₇	24KΩ " "
	X ₂₀₂	" 2SC401	-465-11	R ₃₁₈	470Ω " "
	X ₃₀₁	" 2SC403	-449-31	R ₃₁₉	100Ω " "
	X ₃₀₂	" 2SC403	-437-31	R ₃₂₀	33Ω " "
	X ₃₀₃	" 2SC403	-473-11	R ₃₂₁	1KΩ " "
	X ₃₀₄	" 2SC403	-473-11	R ₃₂₂	1KΩ " "
	X ₃₀₅	" 2SB379	-490-11	R ₃₂₃	5.1KΩ " "
	X ₄₀₁	" 2SC402	-531-11	R ₃₂₄	270KΩ " "
	X ₄₀₂	" 2SC401	-494-11	R ₃₂₅	7.5KΩ " "
	X ₄₀₃	" 2SB383	-494-11	R ₃₂₆	7.5KΩ " "
	X ₄₀₄	" 2SB383	-473-31	R ₃₂₇	1KΩ " "
	D ₁₀₁	Diode SD-111	-473-31	R ₃₂₈	1KΩ " "

* To be adjusted

Part No.	Symbol	Description	Part No.	Symbol	Description
1-240-441-31	R ₃₂₉	47Ω 1/8W Carbon	1-101-959-11	C ₂₁₅	10pF Ceramic
-477-11	R ₃₃₀	1.5KΩ " "	-959-11	C ₂₁₆	10pF "
-499-11	R ₃₃₁	12KΩ " "	-861-11	C ₂₁₇	15pF "
-503-11	R ₃₃₂	18KΩ " "	1-103-614-11	C ₂₁₈	360pF Styrol
-473-31	R ₃₃₃	1KΩ " "	-626-11	C ₂₁₉	1100pF "
1-221-634-12	*R ₃₃₄	1KΩ Adjustable	-637-11	C ₂₂₀	3300pF "
1-240-484-11	R ₃₃₅	3KΩ 1/8W Carbon	1-121-291-11	C ₂₂₁	100μF 6V Electrolytic
-497-11	R ₃₃₆	10KΩ " "	1-105-411-12	C ₂₂₂	0.01μF Mylar
1-221-631-12	*R ₃₃₇	100Ω Adjustable	1-101-141-11	C ₂₂₃	0.01μF Ceramic
1-240-485-11	R ₃₃₈	3.3KΩ 1/8W Carbon	-141-11	C ₃₀₁	0.01μF "
-506-11	R ₃₃₉	24KΩ " "	1-105-413-12	C ₃₀₂	0.022μF Mylar
-460-11	R ₃₄₀	300Ω " "	1-121-291-11	C ₃₀₃	100μF 6V Electrolytic
	R ₃₄₁	-deleted-	1-105-411-12	C ₃₀₄	0.01μF Mylar
1-240-506-11	R ₃₄₂	24KΩ 1/8W Carbon		C ₃₀₅	Built-in IFT _{A301}
1-201-864-11	R ₄₀₁	5.6KΩ " Composition		C ₃₀₆	Built-in IFT _{F301}
-872-11	R ₄₀₂	560Ω " "	1-101-951-11	C ₃₀₇	1pF Ceramic
-951-11	R ₄₀₃	20Ω " "	1-105-411-12	C ₃₀₈	0.01μF Mylar
1-202-113-11	R ₄₀₄	150KΩ " "	1-101-952-11	C ₃₀₉	2pF Ceramic
1-201-278-11	R ₄₀₅	30Ω " "	1-105-413-12	C ₃₁₀	0.022μF Mylar
-277-11	R ₄₀₆	300Ω " "	-413-12	C ₃₁₁	0.022μF "
-968-11	R ₄₀₇	51Ω " "	1-121-280-11	C ₃₁₂	5μF 12V Electrolytic
-650-11	R ₄₀₈	1.8KΩ " "		C ₃₁₃	Built-in IFT _{A302}
-401-11	R ₄₀₉	2.2Ω 1/4W		C ₃₁₄	Built-in IFT _{F302}
-859-11	R ₄₁₀	360Ω 1/8W	1-101-961-11	C ₃₁₅	12pF Ceramic
-863-11	R ₄₁₁	2.2KΩ " "		C ₃₁₆	Built-in IFT _{A303}
1-202-085-11	R ₄₁₂	56KΩ " "	1-101-952-11	C ₃₁₇	2pF Ceramic
1-201-637-11	R ₄₁₃	1.1KΩ " "	1-103-608-11	C ₃₁₈	200pF Styrol
-862-11	R ₄₁₄	1KΩ " "	1-101-951-11	C ₃₁₉	1pF Ceramic
			1-105-411-12	C ₃₂₀	0.01μF Mylar
			-413-12	C ₃₂₁	0.022μF "
				C ₃₂₂	Built-in IFT _{A304}
				C ₃₂₃	Built-in IFT _{F303}
				C ₃₂₄	Built-in IFT _{F304}
				C ₃₂₅	Built-in IFT _{F305}
1-151-088-12	C _{V101-102}	Capacitor, FM tuning	1-101-955-11	C ₃₂₆	5pF Ceramic
-133-11	C _{T101-102}	Trimmer, 2 units (FM)	-955-11	C ₃₂₇	5pF "
1-141-015-00	C _{V201-203}	Capacitor, AM tuning	1-103-601-11	C ₃₂₈	100pF Styrol
1-151-134-11	C _{T201-209}	Trimmer, 3 units x3 (AM)	1-105-411-12	C ₃₂₉	0.01μF Mylar
1-101-090-11	C _{F201}	Capacitor, fine tuning (AM)	1-101-952-11	C ₃₃₀	2pF Ceramic
-791-11	C ₁₀₁	25pF Ceramic	1-105-411-12	C ₃₃₁	0.01μF Mylar
-861-11	C ₁₀₂	70pF "		C ₃₃₂	Built-in IFT _{F306}
-028-11	C ₁₀₃	15pF "	1-103-608-11	C ₃₃₃	200pF Styrol
-951-11	C ₁₀₄	50pF "		C ₃₃₄	Built-in IFT _{F307}
-141-11	C ₁₀₅	1pF "	1-103-608-11	C ₃₃₅	200pF Styrol
-862-11	C ₁₀₆	0.01μF "	-608-11	C ₃₃₆	200pF "
-141-11	C ₁₀₇	18pF "	1-121-282-11	C ₃₃₇	10μF 12V Electrolytic
-954-11	C ₁₀₈	0.01μF "	1-127-044-11	C ₃₃₈	0.047μF AloX
-141-11	C ₁₀₉	4pF "	1-105-413-12	C ₃₃₉	0.022μF Mylar
	C ₁₁₀	0.01μF "	1-121-282-11	C ₃₄₀	10μF 12V Electrolytic
	C ₁₁₁	-deleted-	1-105-412-11	C ₃₄₁	0.015μF Mylar
1-101-871-11	C ₁₁₂	30pF Ceramic	-411-12	C ₃₄₂	0.01μF "
-141-11	C ₁₁₃	0.01μF "	-413-12	C ₃₄₃	0.022μF "
-953-11	C ₁₁₄	3pF "	-411-12	C ₃₄₄	0.01μF "
-861-11	C ₁₁₅	15pF "	1-101-864-11	C ₃₄₅	20pF Ceramic
-141-11	C ₁₁₆	0.01μF "	1-121-359-11	C ₃₄₆	500μF 6V Electrolytic
-961-11	C ₁₁₇	12pF "	-322-11	C ₃₄₇	50μF 6V "
1-105-821-12	C ₁₁₈	0.001μF Mylar	1-101-864-11	C ₃₄₈	20pF Ceramic
1-101-799-11	C ₁₁₉	2000pF Feed Through	1-121-282-11	C ₄₀₁	10μF 12V Electrolytic
-799-11	C ₁₂₀	2000pF "		C ₄₀₂	-deleted-
-799-11	C ₁₂₁	2000pF "	1-121-315-11	C ₄₀₃	100μF 6V Electrolytic
-959-11	C ₂₀₁	10pF Ceramic	-287-11	C ₄₀₄	50μF 3V "
-955-11	C ₂₀₂	5pF "	-315-11	C ₄₀₅	100μF 6V "
-959-11	C ₂₀₃	10pF "	1-105-419-12	C ₄₀₆	0.22μF Mylar
1-105-413-12	C ₂₀₄	0.022μF Mylar	-827-12	C ₄₀₇	0.0033μF "
1-121-282-11	C ₂₀₅	10μF 12V Electrolytic	1-121-315-11	C ₄₀₈	100μF 6V Electrolytic
1-105-411-12	C ₂₀₆	0.01μF Mylar	-287-11	C ₄₀₉	50μF 3V "
-413-12	C ₂₀₇	0.022μF "	1-127-019-11	C ₄₁₀	0.1μF AloX
1-101-955-11	C ₂₀₈	5pF Ceramic	1-105-821-12	C ₄₁₁	0.001μF Mylar
-959-11	C ₂₀₉	10pF "	1-127-022-11	C ₄₁₂	0.5μF AloX
-871-11	C ₂₁₀	30pF "			
1-105-411-12	C ₂₁₁	0.01μF Mylar			
-411-12	C ₂₁₂	0.01μF "			
-411-12	C ₂₁₃	0.01μF "			
-413-12	C ₂₁₄	0.022μF "			

* To be adjusted

SONY CORPORATION

Serial No. 45,001 and after

TFM-1000W

No. 2

PRODUCTION CHANGE

(Change of Former Service Manual at Page 10 and 11)

Former Type

Serial No. Up to 45,000

Part No.	Description	Q'ty
X-38230-02-2	Chassis Ass'y	1
-01-1	Cabinet Ass'y	1
3-823-001-01	Cabinet, front	1
-002-02	" , back	1
3-998-001-03	Battery Cylinder	1
0-039-796-00	Screw, back cover holding	2

New Type

Serial No. 45,001 and After

Part No.	Description	Q'ty
X-38230-12-2	Chassis Ass'y	1
-15-1	Cabinet Ass'y	1
3-823-071-01	Cabinet, front	1
-042-02	" , back	1
3-998-010-04	Battery Cylinder	1
7-621-661-66	Screw, back cover holding	2

Additional

Part No.	Description	Q'ty
3-823-043-01	Lid, battery	1
-048-02	Special Nut	3
-049-01	Coil, spring	2
-050-01	Pin, ext. antenna	2
-058-02	Knob, lock	1
-059-01	Plate, lock	1
-060-02	Spring, lock	1
-061-01	Washer, lock	1
3-821-473-03	Crystal Lid	1
7-621-461-46	Screw, machine +T 3×6	3
-721-61	" , tapping +R 2.6×5	3
-722-41	" , tapping +R 3×6	5
7-624-106-01	Retaining Ring, E-3	2

Deleted

Part No.	Description	Q'ty
0-039-768-00	Cushion	2
3-822-948-01	Screw, TA2.6×6	2
7-621-999-03	" , hexagonal 3×12	4
-999-33	" , hexagonal 3×22	5
7-622-107-02	Nut, 2.6φ	2
-108-02	" , 3φ	5
1-507-036-02	Jack, antenna	1

SONY[®]
SERVICE MANUAL

Exploded Diagram

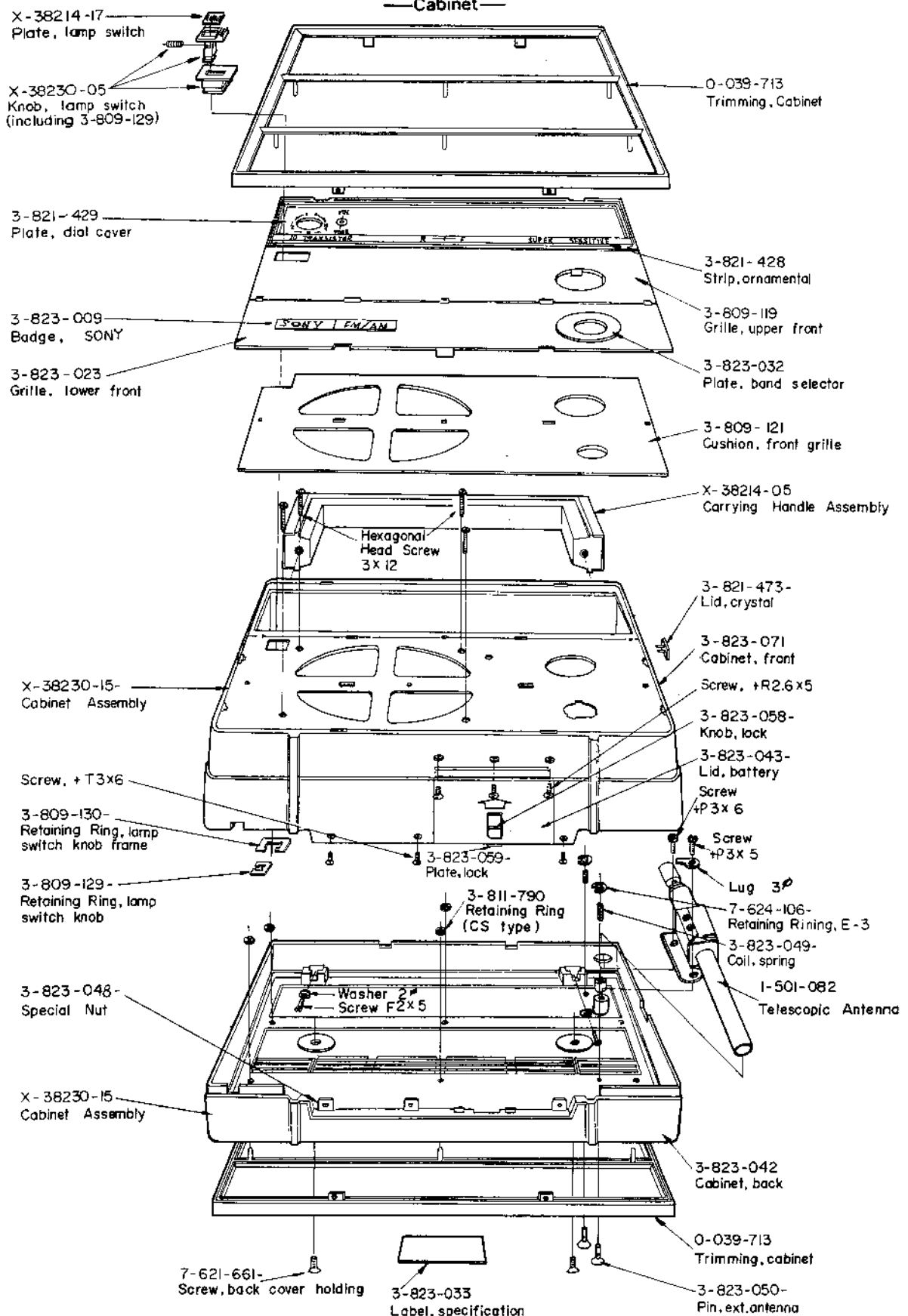

Exploded Diagram

—Chassis—

