

TCS-2000

SERVICE MANUAL

US Model
Canadian Model
AEP Model
UK Model
E Model

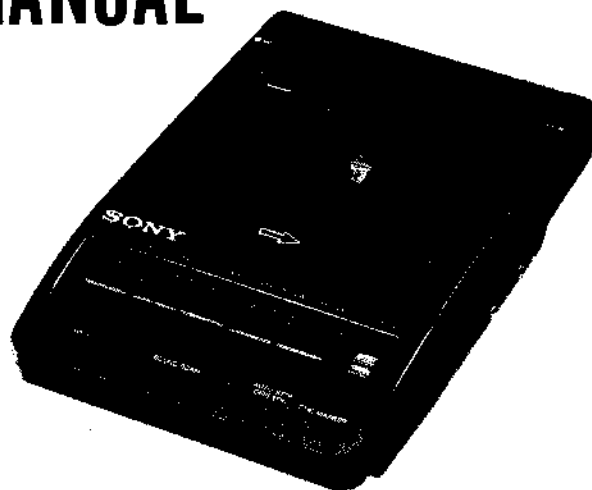

SPECIFICATIONS

Recording system	4-track 2-channel stereo
Speaker	Approx. 6.6 cm (2 5/8 inches) x 3.8 cm (1 1/2 inches)
Frequency response	100-10,000 Hz
Input	Microphone input jack (PLUG IN POWER) (stereo minijack) sensitivity 0.3 mV (-68 dB) for 3 kilohms or lower impedance microphone
Output	Headphones output jack (stereo minijack) load impedance 8 to 300 ohms
Power output	Headphones: 6 mW + 6 mW (16 ohms, at 10% harmonic distortion)
Power requirements	Speaker: 230 mW (at 10% harmonic distortion) 6V DC, four size AA (R6) batteries DC IN 6V jack accepts: optional Sony AC-D4M AC power adaptor for use on 120V AC, 60Hz optional Sony DCC-127A car battery cord for use on 12V car battery

Battery life (hours)

Batteries	Recording	Playback (speaker)	Playback (headphones)
Sony alkaline battery AM3(N)	Approx. 5	Approx. 5	Approx. 5.5

For maximum performance, we recommend the use of alkaline batteries.

Dimensions	Approx. 131 x 42.2 x 202.8 mm (w/h/d) (5 1/4 x 1 11/16 x 8 inches) incl. projecting parts and controls
Weight	Approx. 700 g (1 lb 9 oz) incl. batteries, not incl. other accessories
Supplied accessory	Carrying case (1)
Optional accessories	AC power adaptor AC-D4M Car battery cord DCC-127A Electret condenser stereo microphone ECM-202 Stereo headphones MDR-A10L Head demagnetizer HE-5C Head cleaner KK-31 Foot switch FS-10A

Your dealer may not handle some of the above listed optional accessories. Please ask the dealer for detailed information about the optional accessories available in your country.

Design and specifications subject to change without notice.



Model Name	Using Similar Mechanism	New
Tape Transport Mechanism Type		MT-2000-61

Note: Use only the recommended AC power adaptor or car battery cord manufactured by Sony. Polarity of the plugs of other manufacturers may be different.



polarity of the Sony plug

FEATURES

- **Sound scan function** plays back recorded material at approximately 1/4th the time spent for recording, by skipping parts of the contents at certain intervals. This function allows you to quickly check what is recorded on the tape.
- **Cue marker** marks an inaudible cue marker signal at a desired position of the tape during recording. **Auto stop function** quickly locates the cue marker position while playing back.
- **Stereo recording.** Stereo playback is possible with optional stereo headphones.
- **NOISE REDUCTION switch** decreases tape hiss.

STEREO CASSETTE RECORDER
SONY®

TABLE OF CONTENTS

<u>Section</u>	<u>Title</u>	<u>Page</u>	<u>Section</u>	<u>Title</u>	<u>Page</u>
1. GENERAL			4. ELECTRICAL ADJUSTMENTS		
1-1.	Parts Identification	2	4-1.	Tape Recoder Section	6
1-2.	Recording a Cue Marker	3	5. DIAGRAMS		
1-3.	Locating Cue Markers	3	5-1.	Printed Wiring Boards	10
1-4.	Scanning Sound	3	5-2.	Schematic Diagrams	15
2. DISASSEMBLY			6. EXPLODED VIEWS		
2-1.	Cabinet Rear Assy	4	6-1.	Cabinet Section	19
2-2.	Main Board	4	6-2.	Mechanism Section (1) (MT-2000-61)	20
2-3.	Mechanism Deck and Main Board Block	5	6-3.	Mechanism Section (2) (MT-2000-61)	21
2-4.	FR Belt (Bottom) Replacement	5	7. ELECTRICAL PARTS LIST		
3. MECHANICAL ADJUSTMENTS					
		6			22

**SECTION 1
GENERAL**

1-1. PARTS IDENTIFICATION

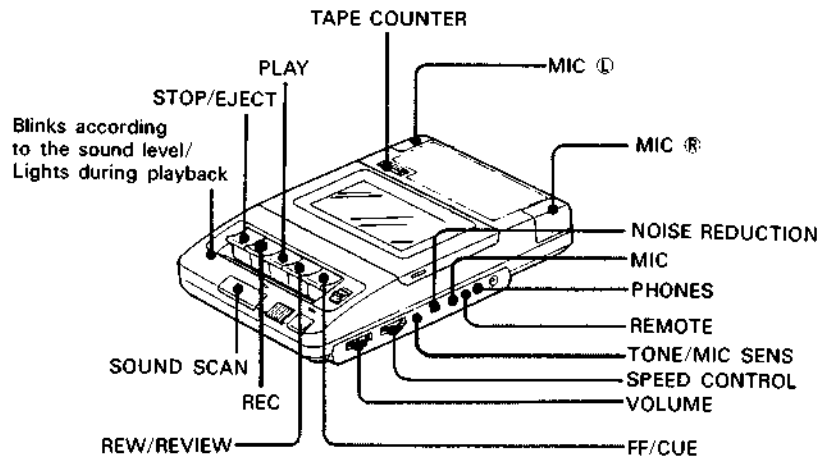

1-2. RECORDING A CUE MARKER

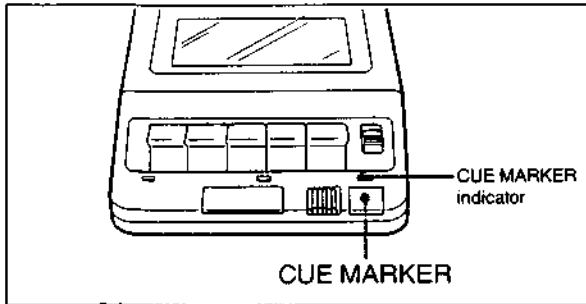

During recording, press CUE MARKER at the position you want to listen to later. The CUE MARKER indicator lights up, and a cue marker is recorded.

Notes on the cue marker

- You can record as many cue markers as you want.
- If you press STOP immediately after pressing CUE MARKER, the cue marker is not recorded.
- After pressing CUE MARKER, wait until the indicator goes out before continuing to record.

1-3. LOCATING CUE MARKERS

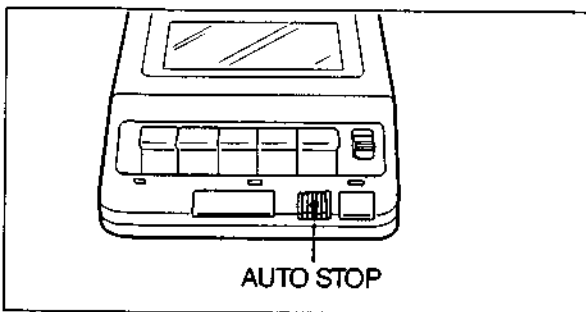

- 1 Play back the tape with the cue markers.
- 2 Set AUTO STOP to ON.
- 3 Keep pressing FF/CUE or REW/REVIEW. At the cue marker position, a beep tone is heard and the tape stops automatically. (The beep tone may not be heard if the volume is very low.)
- 4 Release FF/CUE or REW/REVIEW to start playback.

Notes

- The beep tone (cue marker signal) is not heard during normal playback.
- With a tape on which very low frequency sounds are recorded, the tape may stop at an unexpected position.

1-4. SCANNING SOUND

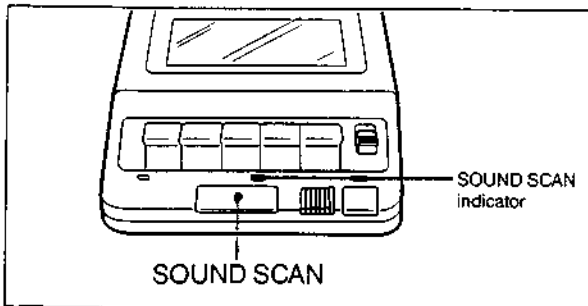

Press SOUND SCAN during playback. The SOUND SCAN indicator lights, and the tape is transported 4 times faster than the normal speed.

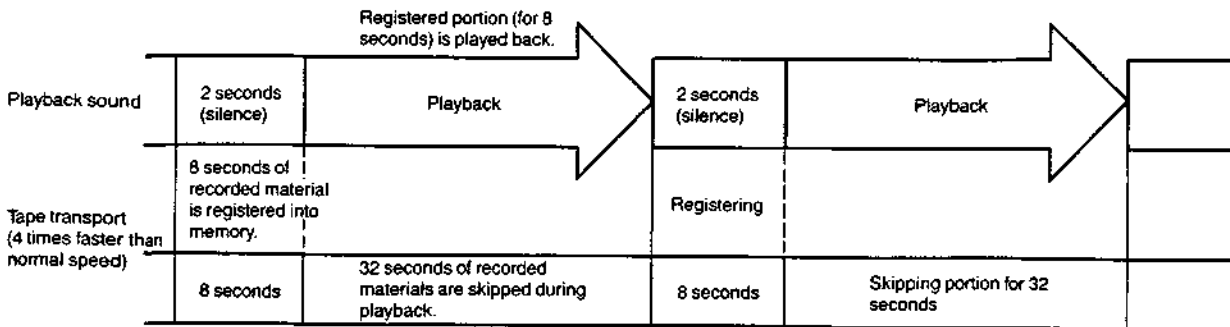

When SOUND SCAN is pressed

In about 2 seconds, 8 seconds of recorded material will be registered in the built-in memory. (Nothing is heard during this period.) Then the registered sound will be played back for 8 seconds. During these 8 seconds, 32 seconds of recording will be skipped. These steps will be repeated, allowing you to check roughly the contents of the tape in about 1/4th of the time spent for recording.

To stop scanning, press SOUND SCAN, FF/CUE, or REW/REVIEW. The unit returns to a normal playback.

Note: The sound is monaural during sound scanning, and the sound quality may differ from the normal playback sound.

SECTION 2 DISASSEMBLY

Note: Follow the disassembly procedure in the numerical order given.

2-1. CABINET REAR ASSY

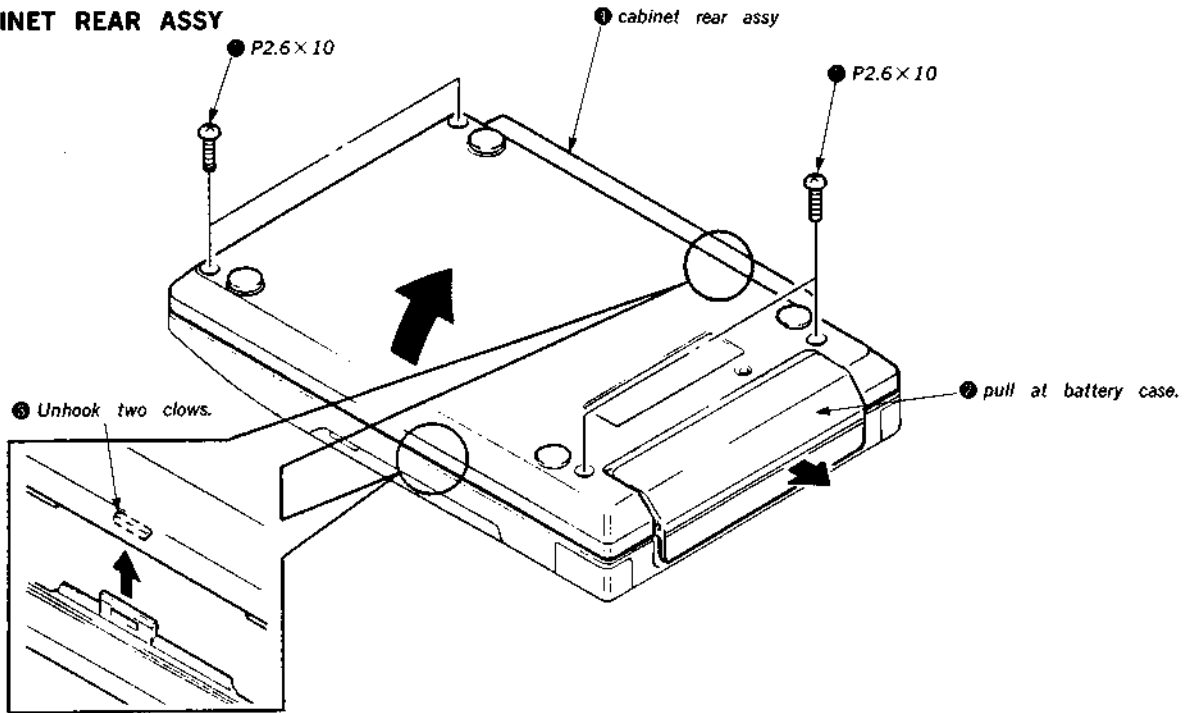

2-2. MAIN BOARD

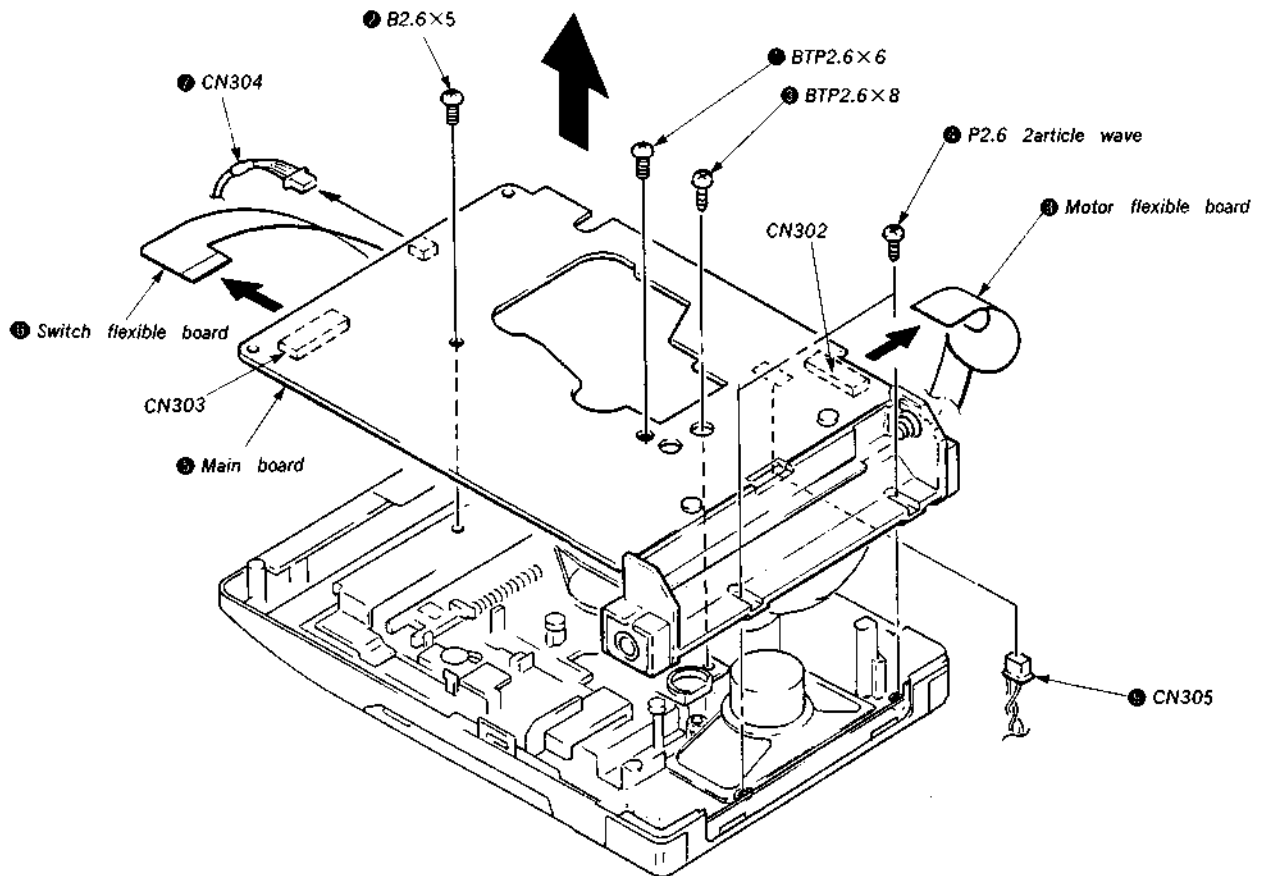

SECTION 3 MECHANICAL ADJUSTMENTS

2-3. MECHANISM DECK AND MAIN BOARD BLOCK

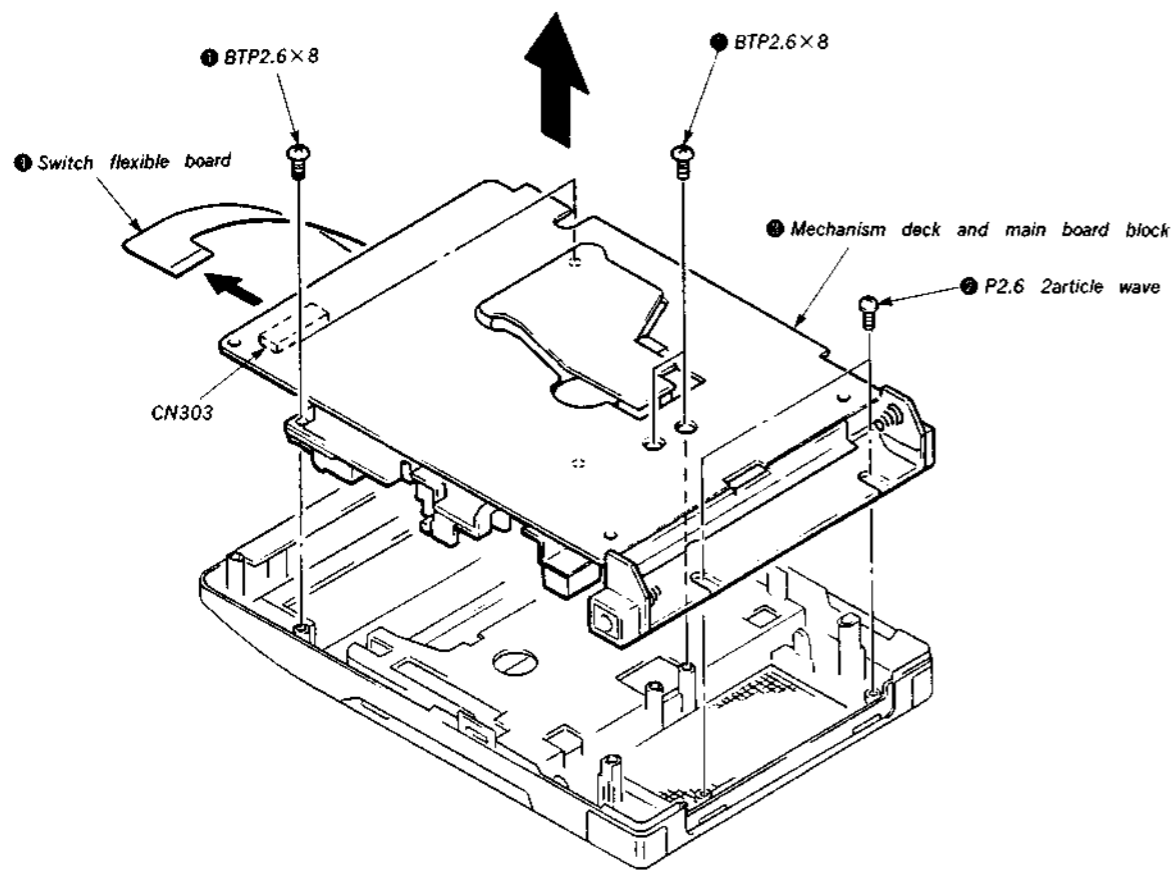

2-4. FR BELT (BOTTOM) REPLACEMENT

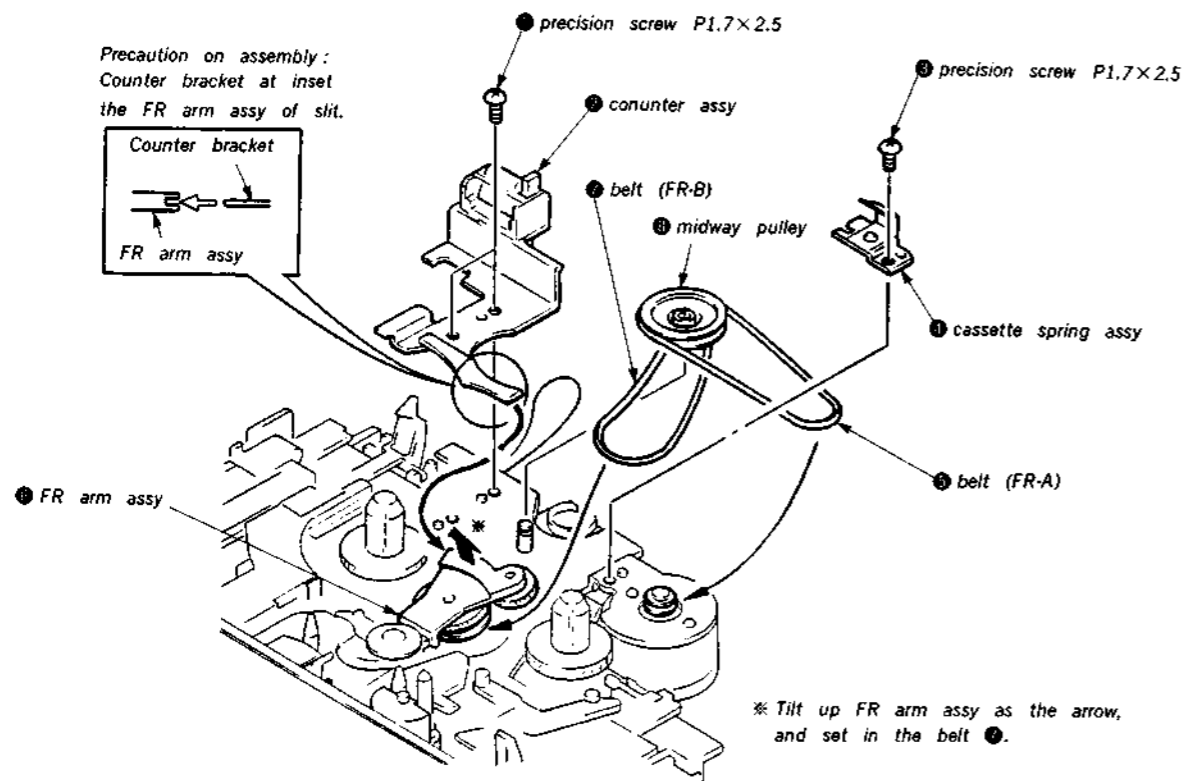

PRECAUTION

- Clean the following parts with a denatured-alcohol-moistened swab:
 - record/playback head
 - erase head
 - capstan
 - pinch rollers
 - rubber belts
 - idlers
- Demagnetize the record/playback head with a head demagnetizer. (Do not bring the head demagnetizer close to the erase head.)
- Do not use a magnetized screwdriver for the adjustments.
- After the adjustments, apply suitable locking compound to the parts adjusted.
- The adjustments should be performed with the rated power supply voltage unless otherwise noted.
 - Power supply voltage : 5Vdc
 - VOLUME : MAX
 - SPEED CONTROL : Center
 - NOISE REDUCTON : OFF
 - TONE/MIC SENS : HIGH
 - AUTO STOP : ON
 - PAUSE : OFF

Torque Measurement

mode	Meter reading	Torque meter
Forward	25 to 45g·cm (0.35 to 0.63oz·inch)	CQ-102C
Fast Forward and Rewind	more than 60g·cm (more than 0.83oz·inch)	CQ-201B
Back Tension	1 to 3g·cm (0.014 to 0.042oz·inch)	CQ-102C

SECTION 4 ELECTRICAL ADJUSTMENTS

4-1. TAPE RECORDER SECTION

• Test Tape

Type	Signal	Used for
WS-48A	3kHz, 0dB	tape speed adjustment
P-4-A063	6.3kHz, -10dB	head azimuth adjustment

Playback Head Azimuth Adjustment

Procedure:

- Mode: playback

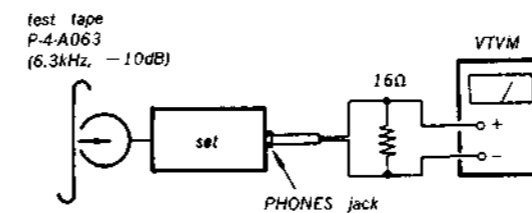

- Turn the adjustment screw for the maximum output levels. If these levels do not match, turn the adjustment screw until both of output levels match together within 0.5dB

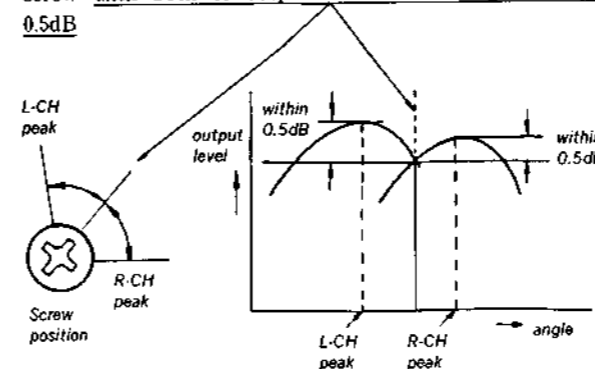

- Phase Check
Mode: playback

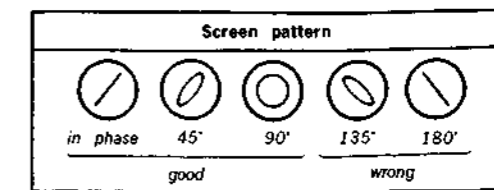
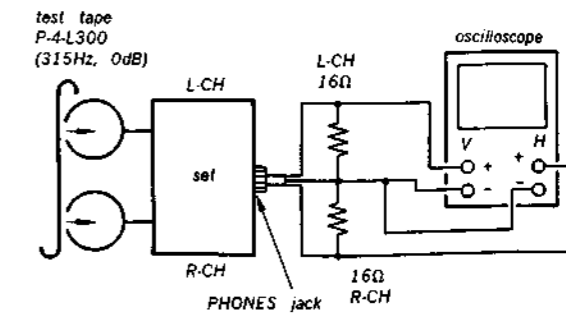

Adjustment Location:

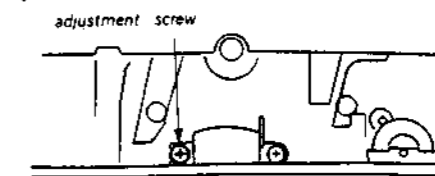

Tape Speed A

Procedure:
Mode: playback

test tape
WS-48A
(3kHz, 0dB)

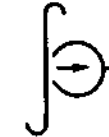

Adjustment Valu

Speed checker
±1%

Adjust RV602 t
difference betwe

PB NR Level

Procedure:

test ta
P-4-L300
(315Hz, 0dB)



Adjust RV101 (I
adjustment level

Adjustment Valu
PB NR level: 0

Level difference

Confirm that the
mode while char
times.

SECTION 3 MECHANICAL ADJUSTMENTS

PRECAUTION

Clean the following parts with a denatured-alcohol-soaked swab:

- Record/playback head
- Erase head
- Stations
- Pinch rollers
- Rubber belts
- Idlers

Magnetize the record/playback head with a head magnetizer. (Do not bring the head demagnetizer close to the erase head.)

Do not use a magnetized screwdriver for the adjustments. For the adjustments, apply suitable locking compound to the parts adjusted.

All adjustments should be performed with the rated power supply voltage unless otherwise noted.

- Power supply voltage : 5Vdc
- VOLUME : MAX
- SPEED CONTROL : Center
- NOISE REDUCTION : OFF
- LINE/MIC SENS : HIGH
- TAPE STOP : ON
- ERASE : OFF

Torque Measurement

mode	Meter reading	Torque meter
Forward	25 to 45g-cm (0.35 to 0.63oz-inch)	CQ-102C
Fast Forward and Rewind	more than 60g-cm (more than 0.83oz-inch)	CQ-201B
Back Tension	1 to 3g-cm (0.014 to 0.042oz-inch)	CQ-102C

SECTION 4 ELECTRICAL ADJUSTMENTS

TAPE RECORDER SECTION

Tape

Signal	Used for
3kHz, 0dB	tape speed adjustment
6.3kHz, -10dB	head azimuth adjustment

Head Azimuth Adjustment

Procedure:

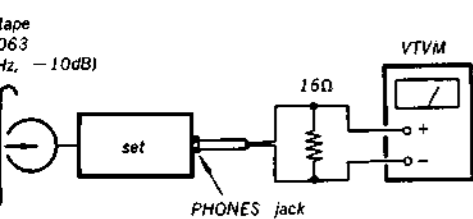

Adjust the adjustment screw for the maximum output level. If these levels do not match, turn the adjustment screw until both of output levels match together within 0.5dB.

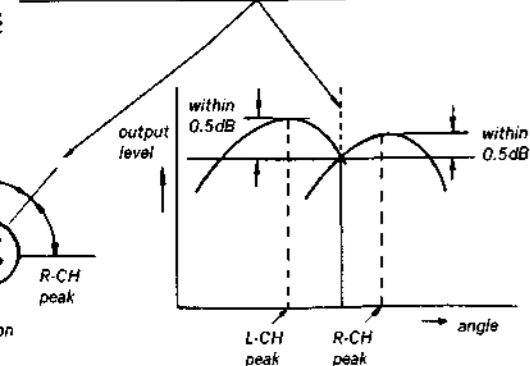

3. Phase Check Mode: playback

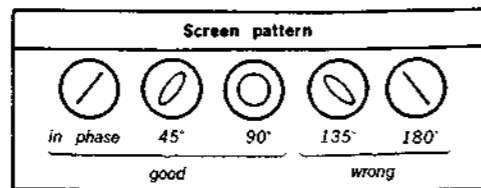
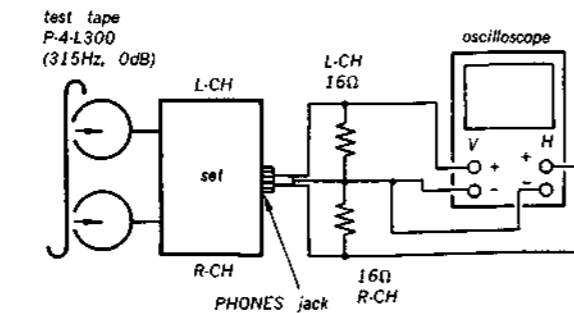

Adjustment Location:

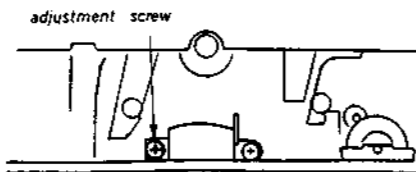

Tape Speed Adjustment

Procedure:
Mode: playback

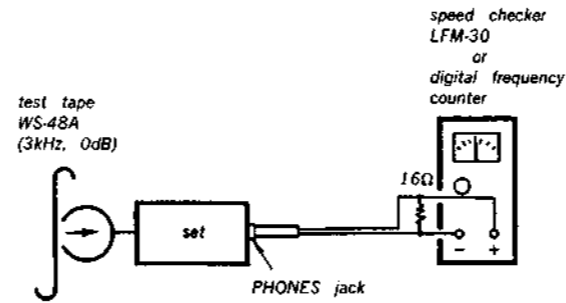

Adjustment Value:

Speed checker	Digital frequency counter
±1%	2,985 to 3,015Hz

Adjust RV602 to be within ±1% so that the frequency difference between the beginning and the end of the tape.

REC NR Level adjustment

Procedure:
1. Mode: record

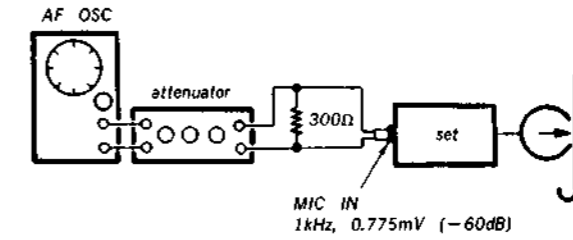

2. Mode: playback

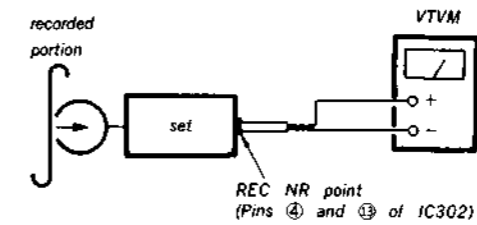

Play back the recorded in step 1. If the adjustment value is not satisfied adjust RV102 (L-CH) and RV202 (R-CH) to repeat step 1 and 2.

Adjustment Value:

REC NR level: 0.0691 to 0.0775V
(-21 to -20dBs)

PB NR Level Adjustment

Procedure:

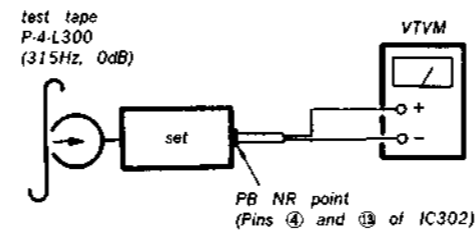

Adjust RV101 (L-CH) and RV201 (R-CH) so that the within adjustment level as follows.

Adjustment Value:

PB NR level: 0.0691 to 0.0775V
(-21 to -20dBs)

Level difference between channels: Within 0.5dB

Confirm that the PB NR level does not change in playback mode while changing the mode from playback to stop several times.

Adjustment Location: main

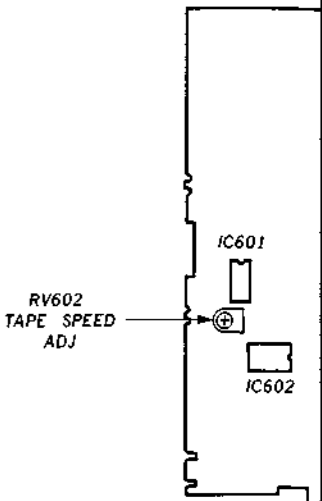

SECTION 5
DIAGRAMS

REC NR Level adjustment

Procedure:

1. Mode: record

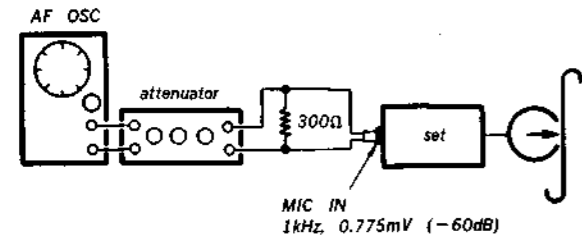

2. Mode: playback

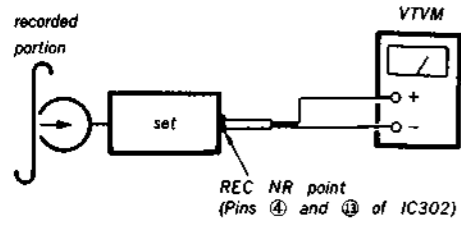

Play back the recorded in step 1. If the adjustment value is not satisfied adjust RV102 (L-CH) and RV202 (R-CH) to repeat step 1 and 2.

Adjustment Value:

REC NR level: 0.0691 to 0.0775V
(-21 to -20dBs)

Adjustment Location: main board (A side)

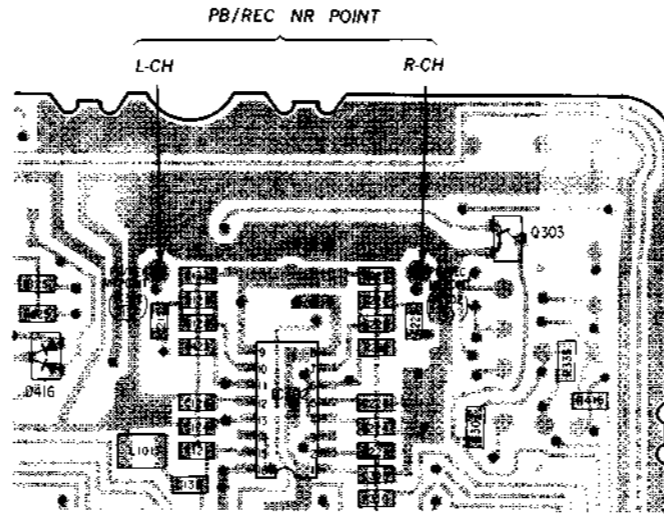
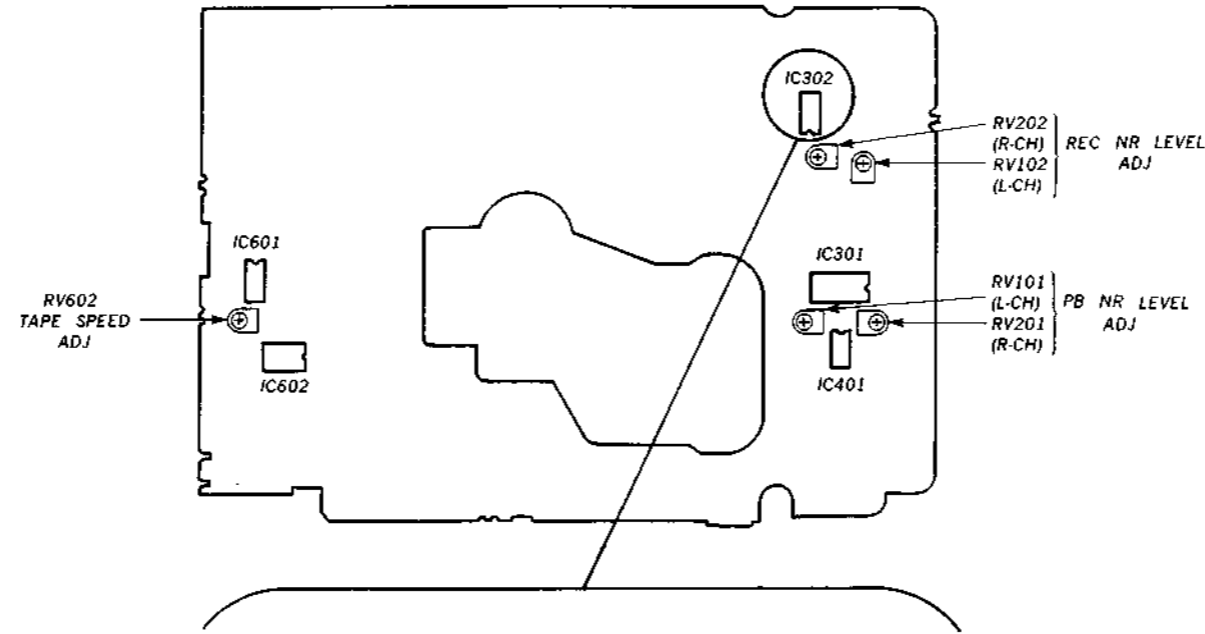

● IC Block Diagrams

IC403 BA3708F

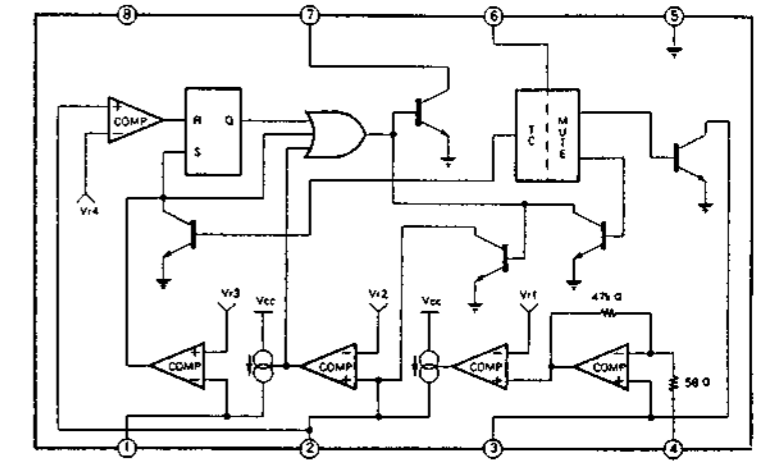

IC301 AN7015S

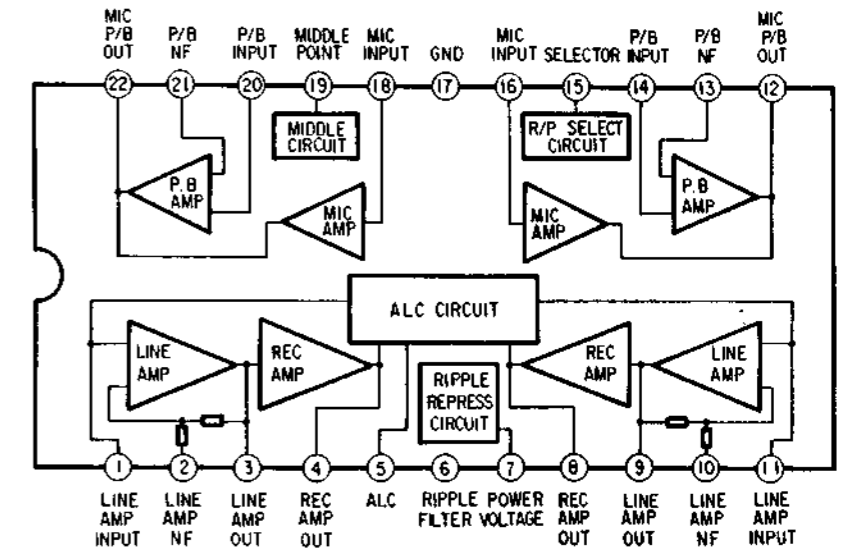

IC603 LA5537

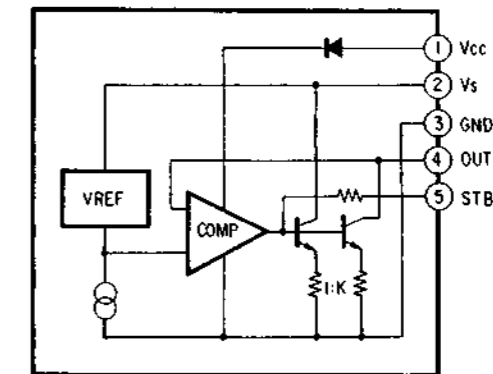

5-1. PRINTED WIRING BOARDS • Refer to page 18 for Semiconductor Lead Layouts.

• Semiconductor Location

Ref. No.	Location	Ref. No.	Location
D301	E-16	Q313	B-9
D302	E-15	Q314	B-6
D303	E-16	Q315	H-14
D304	H-8	Q316	H-7
D401	B-8	Q401	B-8
D402	A-4	Q402	B-9
D403	G-7	Q403	C-12
D404	C-11	Q404	D-11
D405	C-11	Q405	H-6
D406	C-12	Q406	I-6
D407	C-11	Q407	D-4
D408	E-4	Q408	C-11
D409	C-6	Q409	F-4
D410	D-7	Q410	E-11
D412	B-8	Q411	C-4
D413	I-5	Q412	A-5
D414	I-5	Q413	B-4
D415	A-3	Q414	H-6
D416	C-13	Q415	B-10
D601	G-5	Q416	D-8
D602	F-5	Q417	D-8
D603	H-5	Q418	D-7
D604	G-5	Q419	C-29
D901	E-2	Q420	C-29
D902	G-2	Q421	C-28
D903	H-2	Q422	D-28
		Q423	E-29
IC301	F-15	Q424	D-30
IC302	C-14	Q425	F-29
IC303	H-6	Q426	E-29
IC401	G-15	Q427	E-29
IC402	D-11	Q428	E-28
IC403	E-4	Q429	D-29
IC404	B-12	Q430	C-11
IC405	B-11	Q431	D-6
IC406	E-5	Q432	D-4
IC407	C-5	Q601	G-4
IC408	B-29	Q602	F-5
IC601	F-4	Q603	H-4
IC602	G-5	Q604	F-5
IC603	H-4	Q605	G-5
IC604	I-4	Q606	F-5
		Q607	F-5
Q301	J-10		
Q302	H-14		
Q303	B-16		
Q304	I-15		
Q305	H-15		
Q306	E-15		
Q307	D-15		
Q308	D-14		
Q309	I-8		
Q310	G-7		
Q311	H-16		
Q312	H-16		

- : parts extracted from the component side.
- : parts extracted from the conductor side.
- : Through hole.
- ▨ : Pattern on the side which is seen.
- : Pattern of the rear side.

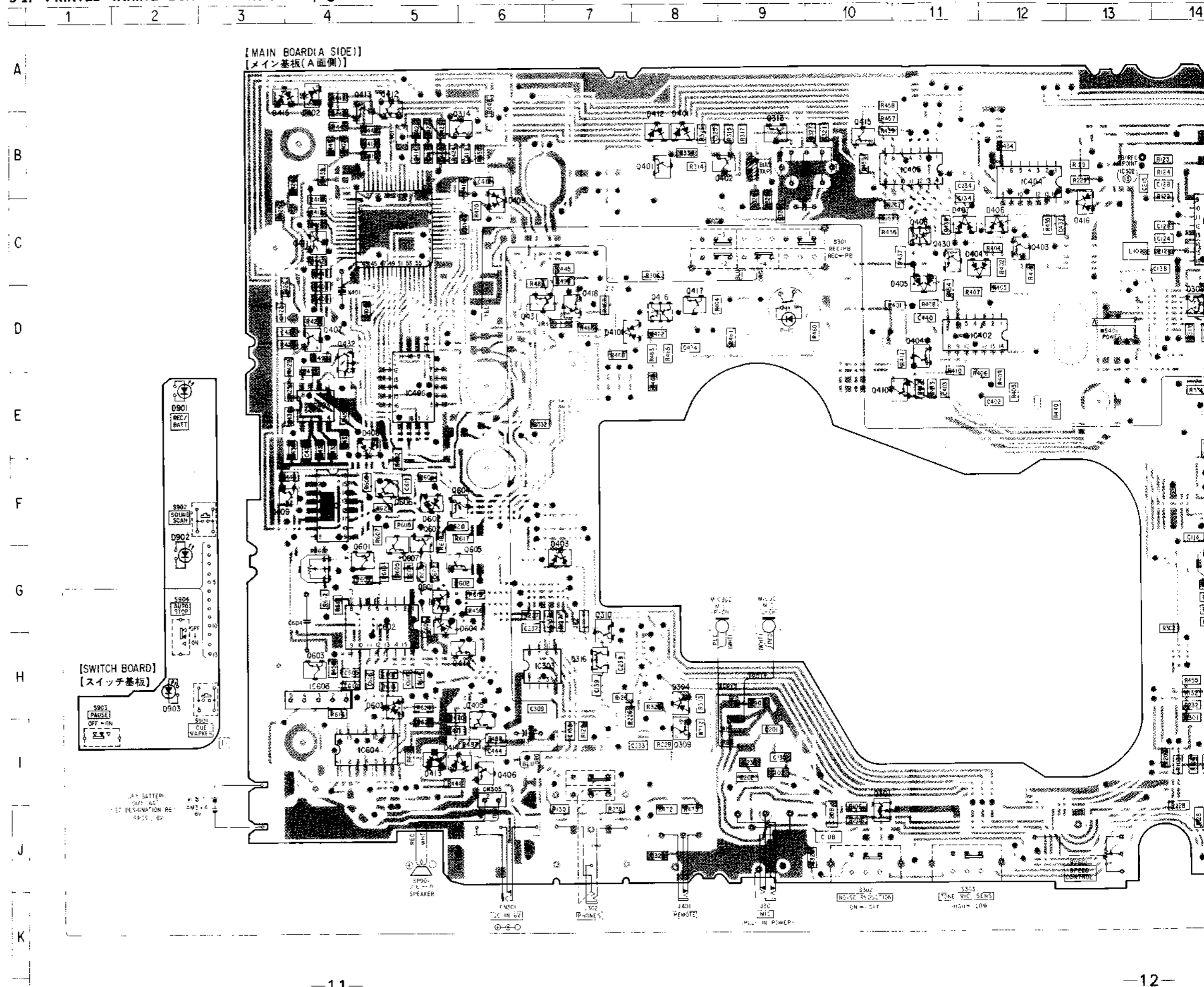

or Semiconductor Lead Layouts.

5 6 7 8 9 10 11 12 13 14 15 16 17 18 19 20 21 22 23

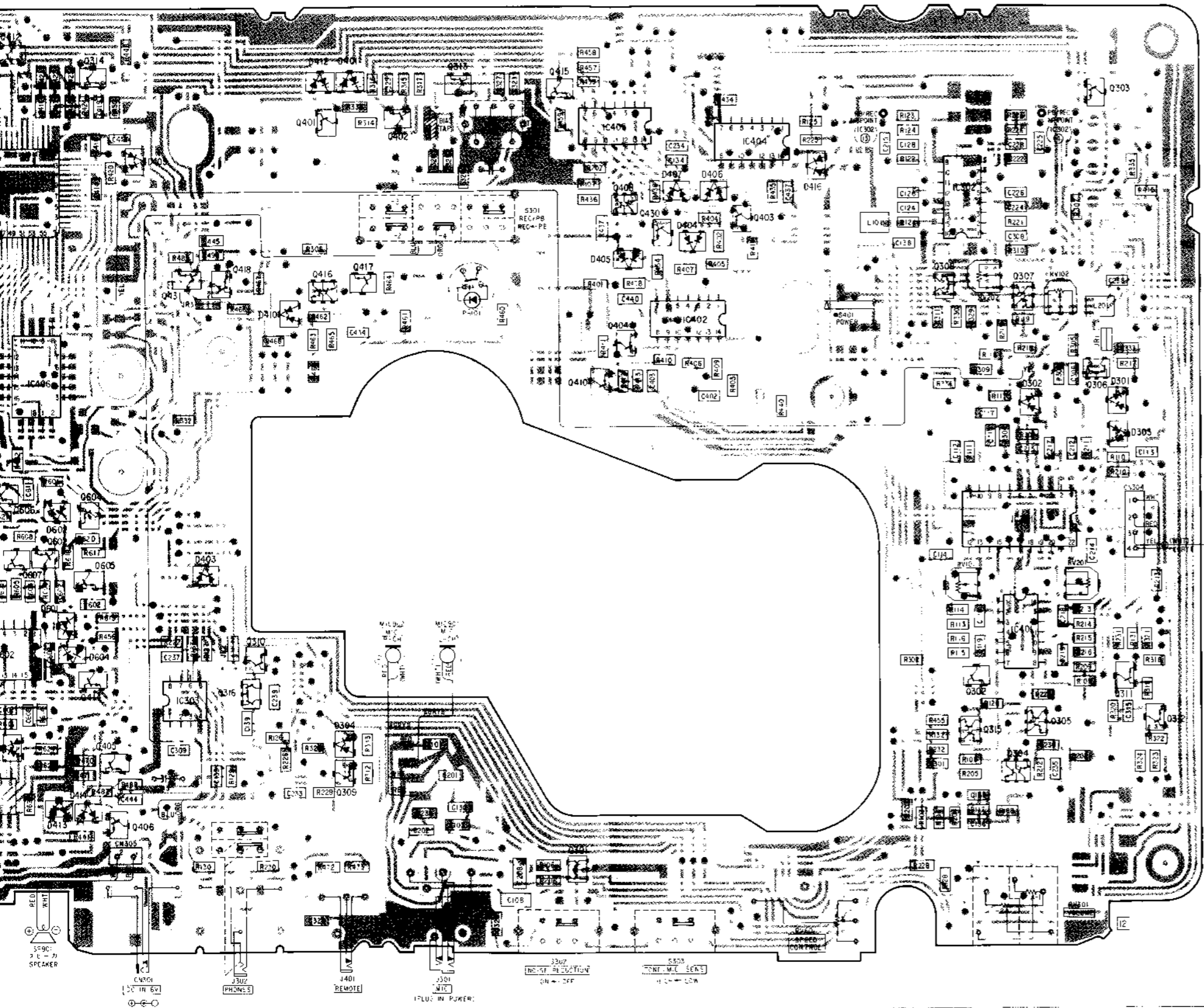

[SWITCH FLEXIBLE BOARD]
[スイッチフレキ基板]

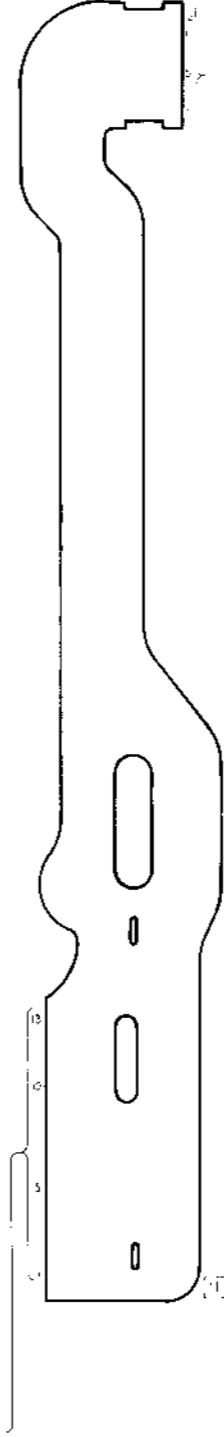

[MAIN BOARD (B SIDE)]
[メイン基板(日面側)]

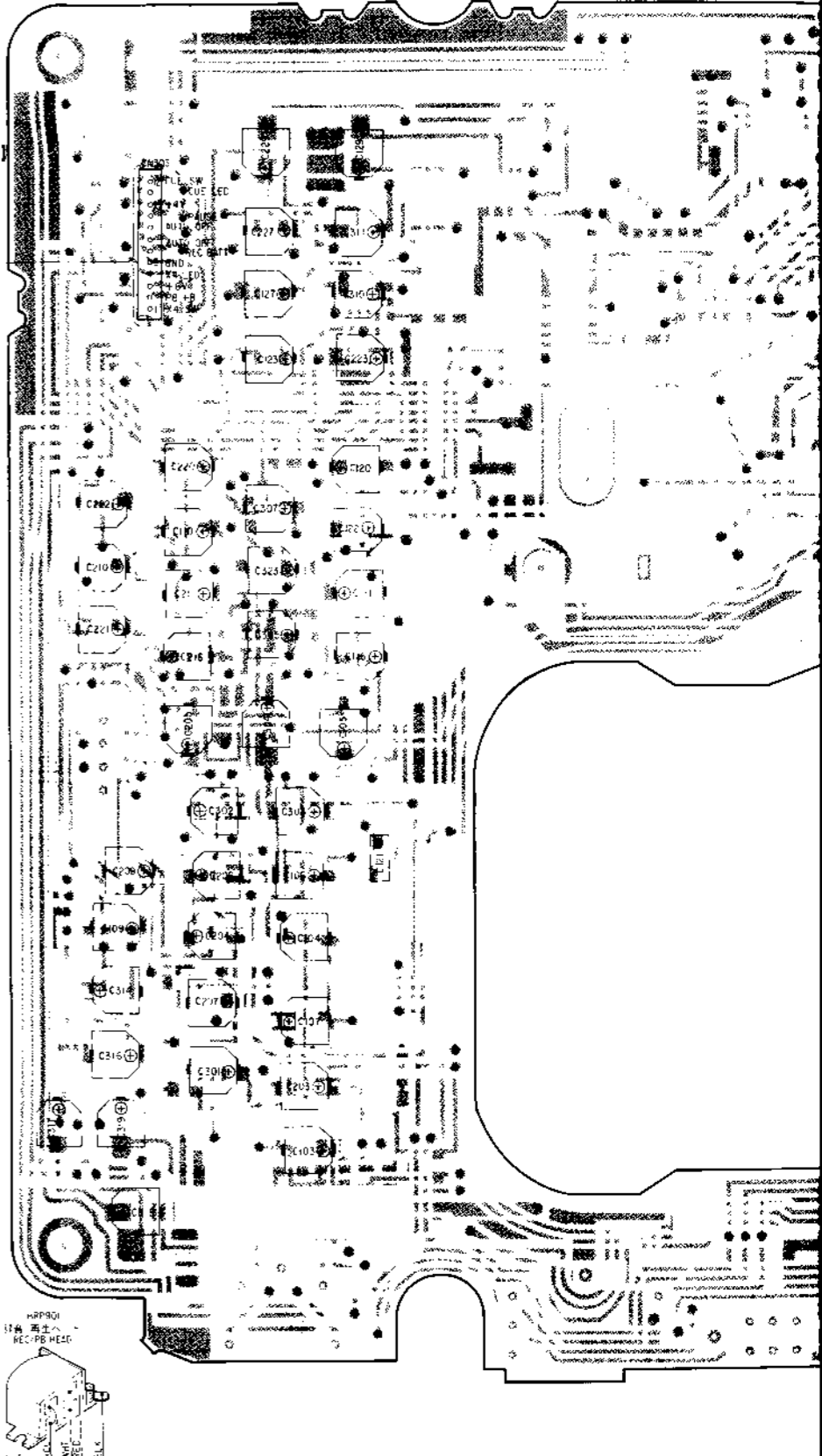

17 18 19 20 21 22 23 24 25 26 27 28 29 30 31 32 33 34 35

[MAIN BOARD (B SIDE)]
[メイン基板(B面側)]

[SWITCH FLEXIBLE BOARD]
[スイッチフレキシブル基板]

[MOTOR FLEXIBLE BOARD]
[モータフレキシブル基板]

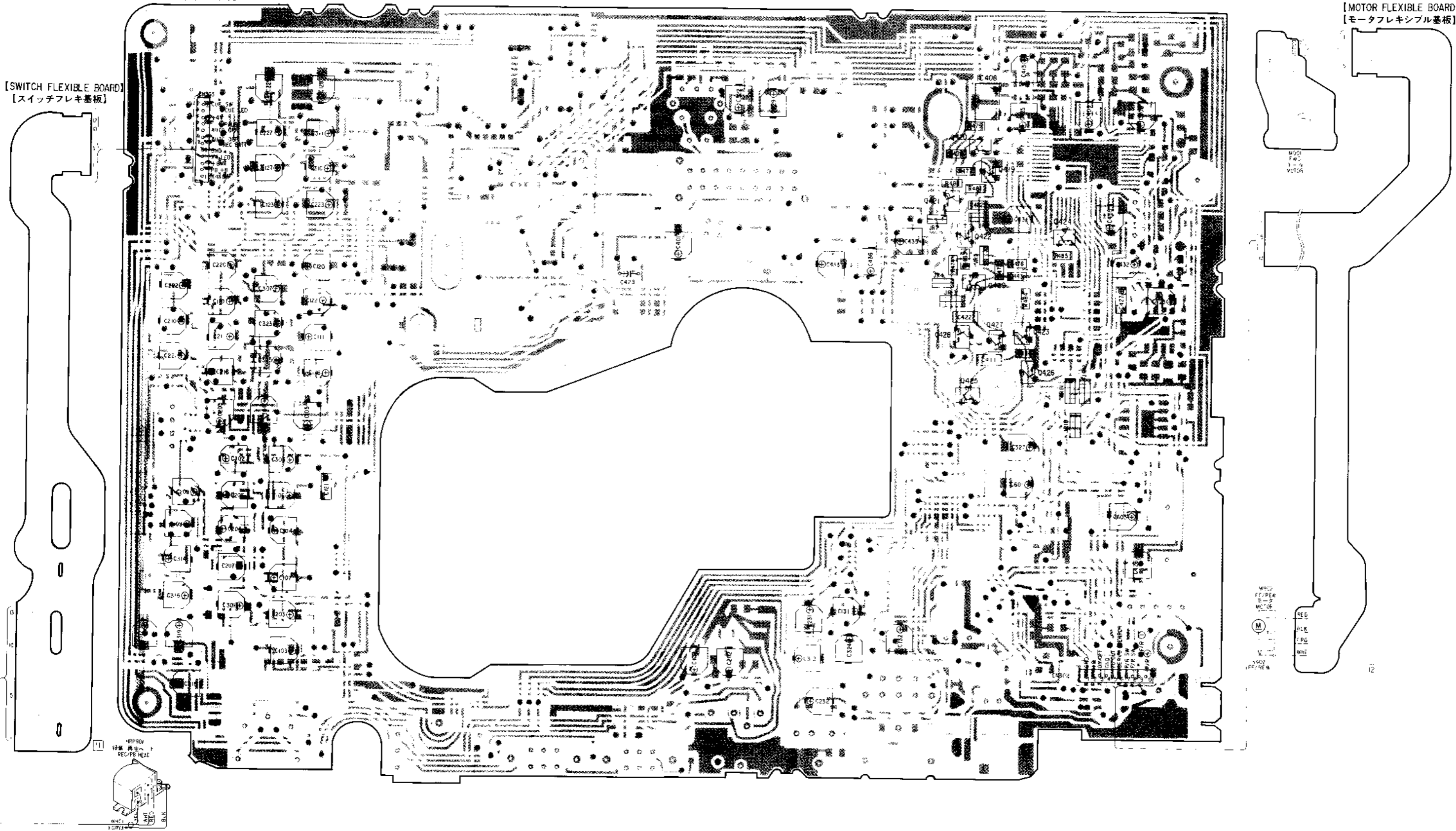

5-2. SCHEMATIC DIAGRAMS

1 2 3 4 5 6 7 8 9 10 11 12 13 14 15 16 17

A
B
C
D
E
F
G
H
I
J

【メイン基板】
【MAIN BOARD】

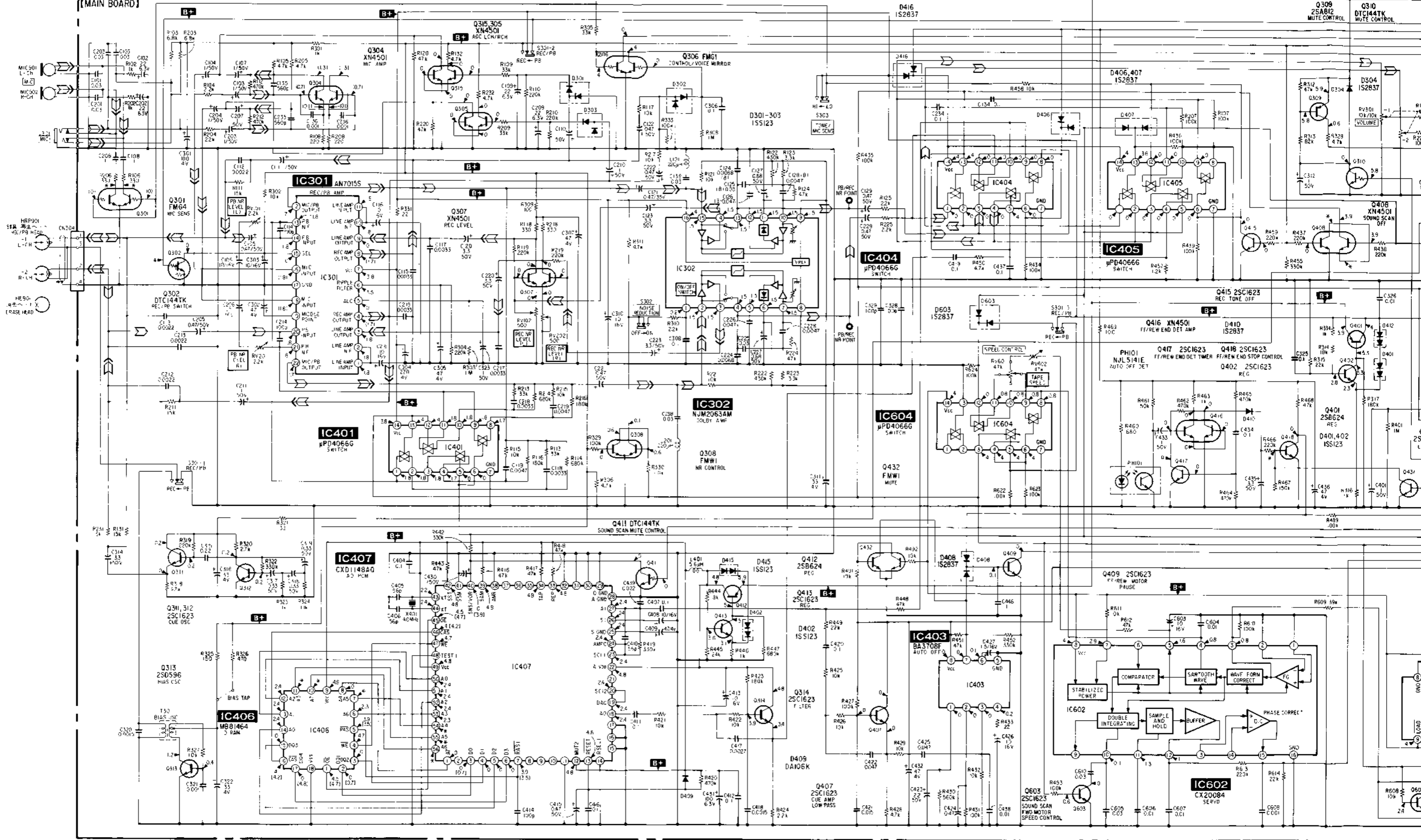

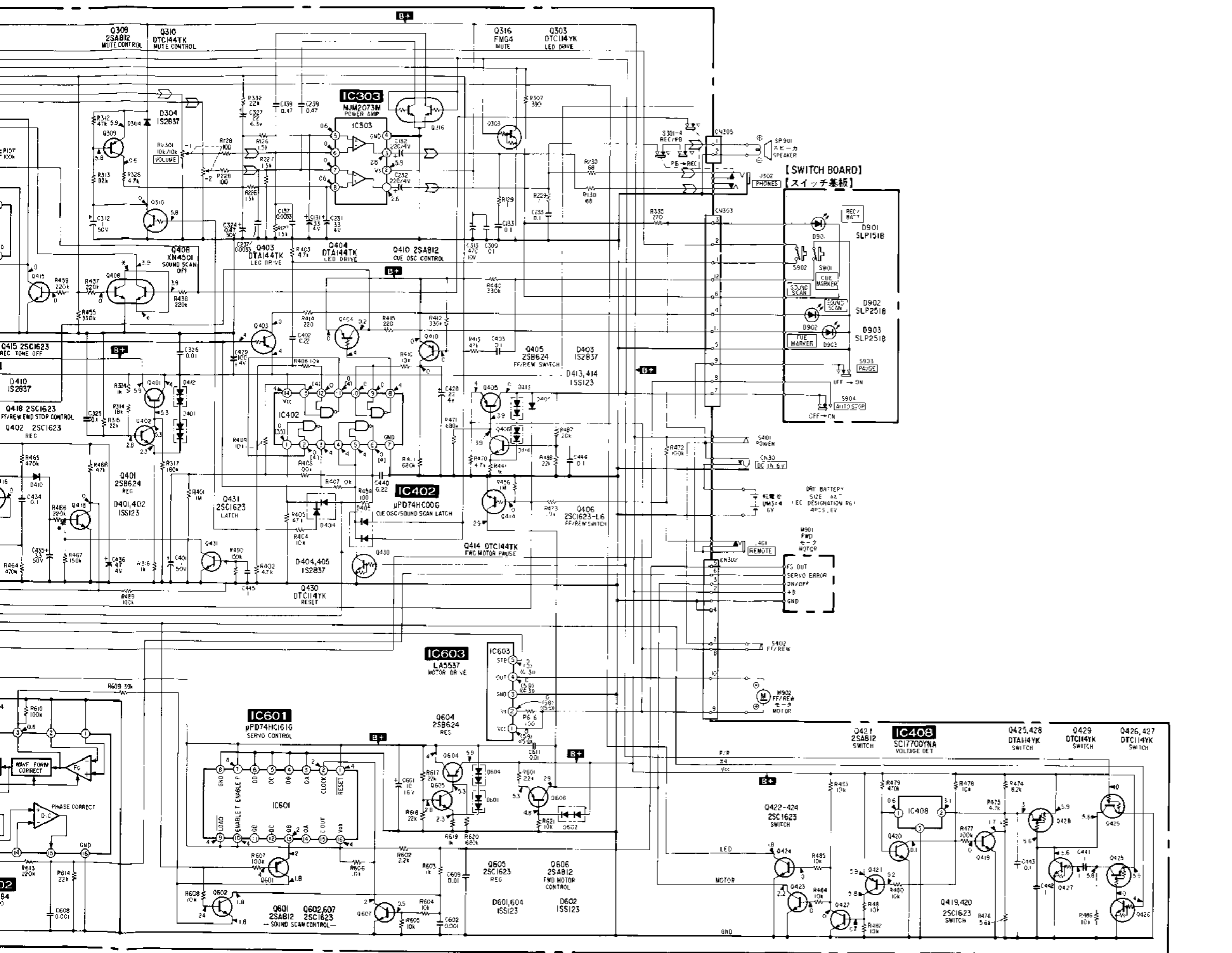

A
B
C
D
E
F
G
H
I
J

CXD1148AQ

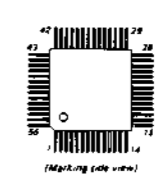

MB81464-12PD



FMG4 FMW1

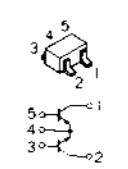

NJL5141E-AA

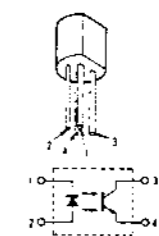

SLP151B-60 SLP251B

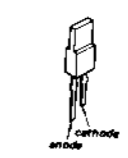

- Note:**
- All capacitors are in μF unless otherwise noted. pF : μF 50WV or less are not indicated except for electrolytics and tantalums.
 - All resistors are in Ω and $1/4\text{W}$ or less unless otherwise specified.
- no mark : PB () : RWD
() : REC < > : impossible measurement
< > : FF
() : SOUND SCAN
- Voltages are taken with a VOM (input impedance $10\text{M}\Omega$) Voltage variations may be noted due to normal production tolerances.
 - Signal path.
 : PB
 : REC

**SECTION 6
EXPLODED VIEWS**

NOTE:

- The mechanical parts with no reference number in the exploded views are not supplied.
- The construction parts of an assembled part are indicated with a collation number in the remark column.
- Items marked "*" are not stocked since they are seldom required for routine service. Some delay should be anticipated when ordering these items.
- Due to standardization, parts with part number suffix -XX and -X may be different from the parts specified in the components used on the set.
- Color Indication of Appearance Parts
Example:
(RED) ... KNOB, BALANCE (WHITE)
↑ Cabinet's Color ↑ Parts' Color

6-1. CABINET SECTION

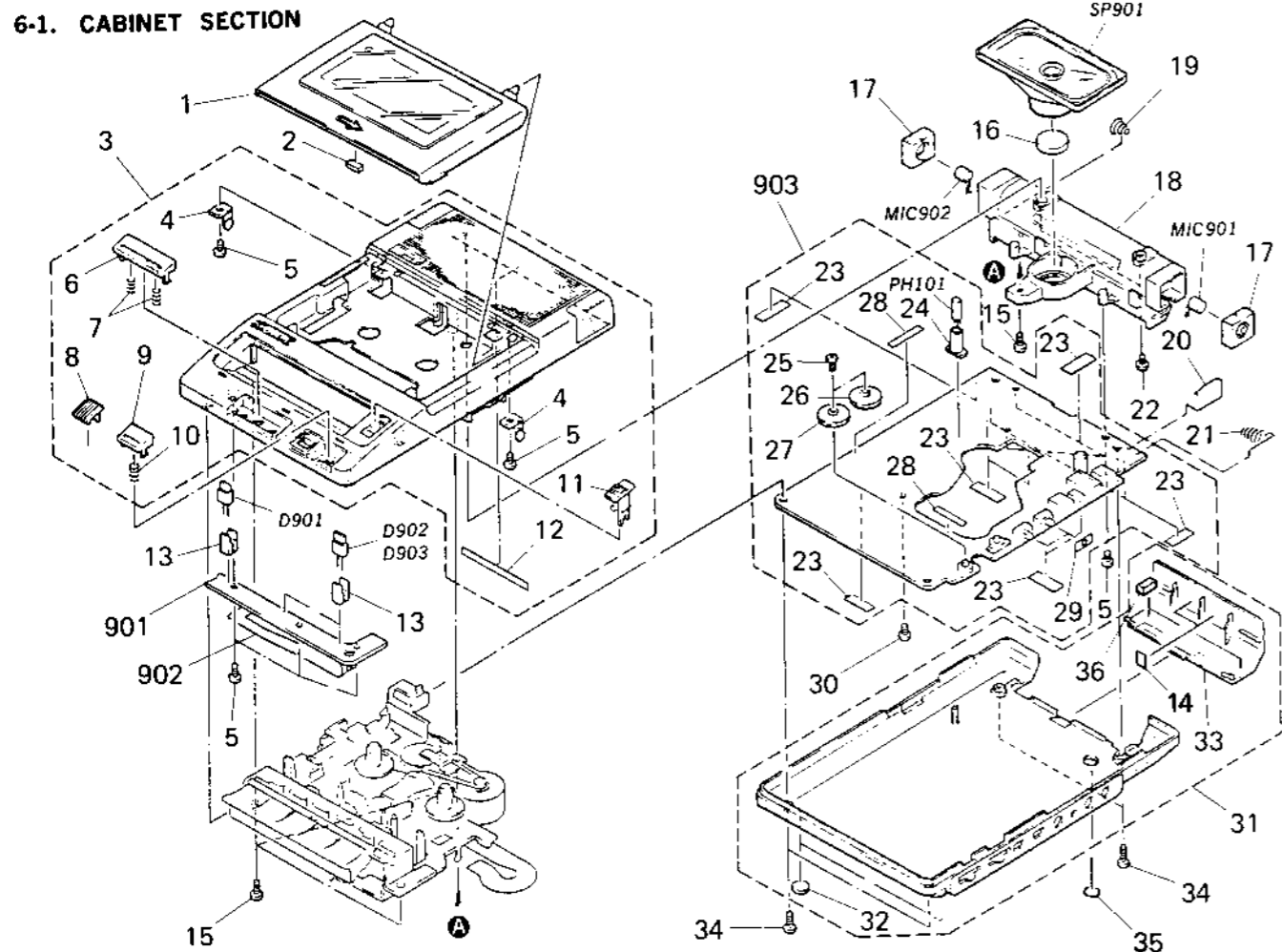

Ref.No	Part No.	Description	Remarks	Ref.No	Part No.	Description	Remarks
1	X-3351-203-1	LID ASSY, CASSETTE		24	3-351-224-01	HOLDER (SENSOR)	
2	3-485-330-21	FELT		25	3-714-118-01	SCREW (1.7X4)	
3	X-3351-204-1	CABINET (FRONT) ASSY		26	3-351-214-01	KNOB (SPEED)	
4	X-3351-201-1	BRACKET (SPRING) ASSY		27	3-351-215-01	KNOB (VOL)	
5	7-685-133-19	SCREW +BTP 2.6X6 TYPE2 N-S		28	3-831-441-11	CUSHION (B)	
6	3-351-219-01	BUTTON (SOUND SCAN)		29	3-305-653-00	PLATE (A), BLIND	
7	3-351-210-01	SPRING, COMPRESSION		30	7-621-770-87	SCREW +B 2.6X5	
8	3-351-205-01	KNOB (AUTO STOP)		31	X-3351-213-1	CABINET (REAR) ASSY	
9	3-351-220-01	BUTTON (CUE MARKER)		32	3-319-288-01	FOOT	
10	3-351-209-01	SPRING, COMPRESSION		33	3-351-226-01	LID, BATTERY CASE	
11	3-351-221-01	KNOB (PAUSE)		34	7-685-135-19	SCREW +P 2.6X10 TYPE2 SLIT	
12	3-831-441-XX	SPACER		35	3-342-380-01	SHEET, SPEED HOLE	
13	3-351-217-01	HOLDER, LED		36	3-831-441-XX	CUSHION (B), CABINET	
14	9-911-845-XX	CUSHION		901	*1-629-354-11	PC BOARD, SWITCH	
15	7-685-134-19	SCREW +BTP 2.6X8 TYPE2 N-S		902	1-629-355-11	PC BOARD, SWITCH FLEXIBLE	
16	3-831-441-XX	CUSHION, SPEAKER		903	*A-3015-719-A	PC BOARD ASSY, MAIN	
17	3-351-201-01	CUSHION (MICROPHONE)		D901	8-719-938-11	DIODE SLP151B-60	
18	*3-351-227-01	CHASSIS, SUB		D902	8-719-902-51	DIODE SLP251B	
19	3-896-450-01	SPRING		D903	8-719-902-51	DIODE SLP251B	
20	3-351-206-01	TERMINAL, PLUS		MIC901	1-542-092-11	MICROPHONE, ELECTRET CONDENSER	
21	3-351-207-01	SPRING		MIC902	1-542-092-11	MICROPHONE, ELECTRET CONDENSER	
22	3-351-290-01	SCREW, (+P 2.6) (2 ARTICLE WAVE)		PH101	8-719-751-42	DIODE NJL5141E-AA	
23	3-831-441-11	CUSHION (B)		SP901	1-544-118-11	SPEAKER	

**6-2. MECHANISM SECTION (1)
(MT-2000-61)**

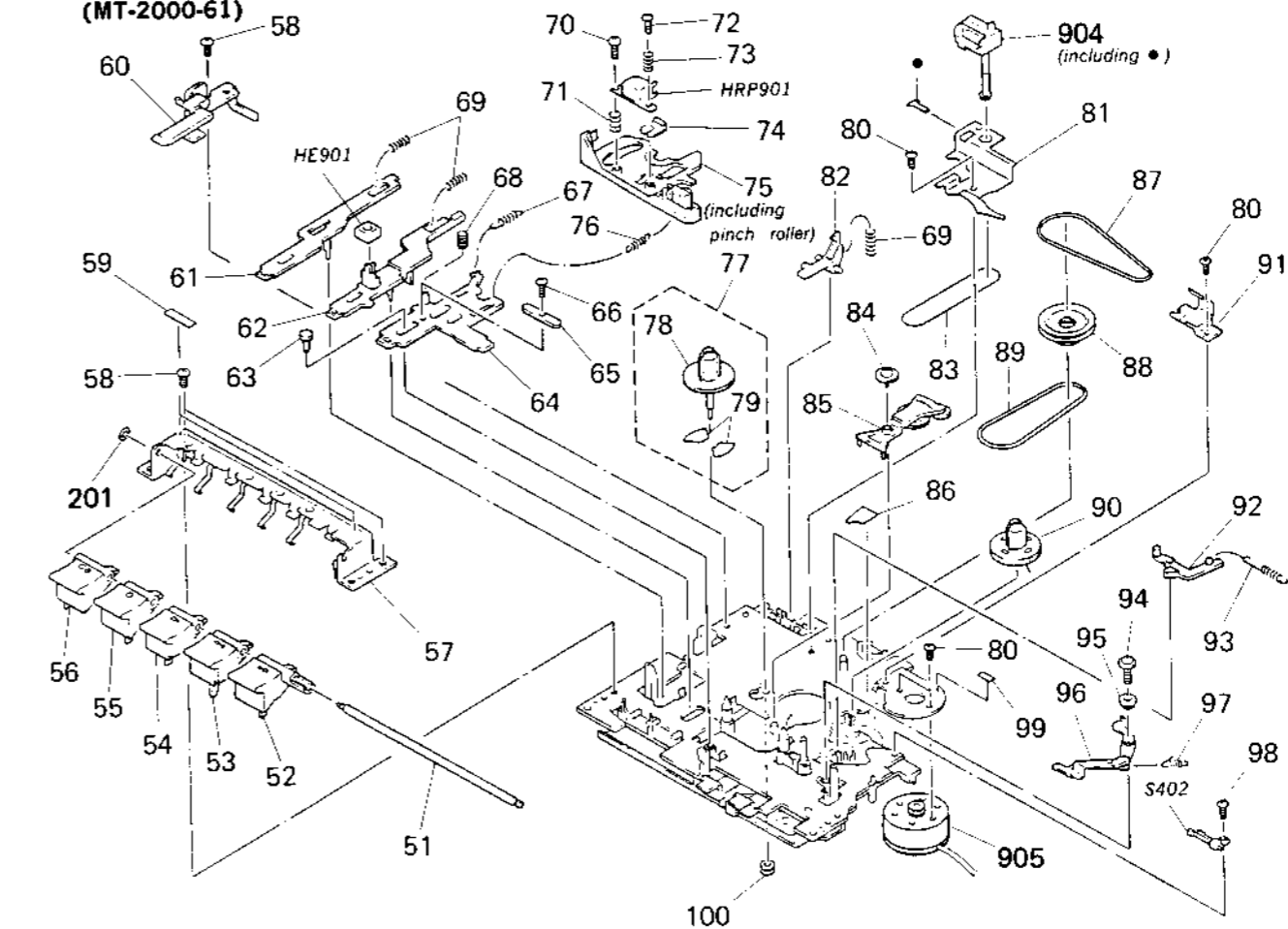

Ref.No	Part No.	Description	Remarks	Ref.No	Part No.	Description	Remarks
51	3-351-235-01	SHAFT (BUTTON)		79	3-351-271-01	REFLECTOR	
52	3-351-265-01	BUTTON (FF)		80	7-627-852-07	SCREW, PRECISION +P 1.7X2.5	
53	3-351-264-01	BUTTON (REW)		81	*3-351-257-01	BRACKET (COUNTER)	
54	3-351-261-01	BUTTON (PLAY)		82	3-343-345-01	LEVER, SAFETY	
55	3-351-263-01	BUTTON (REC)		83	3-351-249-01	BELT	
56	3-351-262-01	BUTTON (STOP)		84	3-343-359-01	BUSHING	
57	*X-3351-207-1	GUIDE ASSY, BUTTON		85	X-3351-210-1	ARM ASSY, FR	
58	7-627-553-37	PRECISION SCREW +P 2X3 TYPE 3		86	*3-349-756-01	SPACER (FF GEAR)	
59	3-831-441-11	CUSHION (B)		87	3-351-240-01	BELT	
60	X-3351-208-1	HOLDER ASSY, EJECT		88	3-351-231-01	PULLEY (MIDWAY)	
61	3-343-335-01	LEVER, STOP		89	3-351-239-01	BELT	
62	3-351-258-01	LEVER, REC		90	X-3343-322-1	GEAR ASSY, T REEL	
63	3-351-278-01	SHAFT (LEVER STOPPER)		91	X-3351-206-1	SPRING ASSY	
64	3-343-342-17	LEVER, PLAY		92	*X-3351-212-1	LEVER (P) ASSY, JOINT	
65	*3-343-380-01	STOPPER, HEAD BASE		93	3-351-269-01	SPRING, TENSION	
66	3-336-735-11	SCREW (1.4X3), TAPPING		94	3-319-501-41	SCREW (+ PTPWH) (2.6X5)	
67	3-351-277-01	SPRING, TENSION		95	3-343-256-01	SPACER (D)	
68	*3-343-264-61	COLLAR, SPRING		96	*3-345-840-11	LEVER (FR)	
69	3-343-346-01	SPRING, COMPRESSION		97	3-343-374-01	SPRING, TENSION	
70	3-342-067-01	SCREW (2X3 5), AZIMUTH		98	3-343-253-21	SCREW (M1.6X3.8)	
71	3-342-028-01	SPRING, COMPRESSION		99	*3-329-460-01	SPACER	
72	7-627-553-87	SCREW, PRECISION +P 2X7		100	3-351-242-01	PULLEY (COUNTER)	
73	3-318-237-01	SPRING, COMPRESSION		201	3-321-813-21	WASHER, COTTER POLYETHYLENE	
74	3-336-274-01	SHIM (T=0.1)		904	1-550-463-11	COUNTER, TAPE (ULTRA SMALL)	
74	3-336-274-11	SHIM (T=0.2)		905	A-3133-368-A	MOTOR BLOCK ASSY (INCLUDING M902)	
75	X-3351-205-1	BASE ASSY, HEAD (including pinch roller)		HE901	1-543-474-11	HEAD, MAGNETIC (ERASE)	
76	3-351-276-01	SPRING, TENSION		HRP901	1-543-526-11	HEAD, MAGNETIC (REC/PB)	
77	X-3343-336-1	GEAR ASSY, S REEL		S402	1-571-348-11	SWITCH, LEAF (FF/REW)	
78	3-342-013-01	GEAR, S REEL					

**6-3. MECHANISM
(MT-2000-61)**

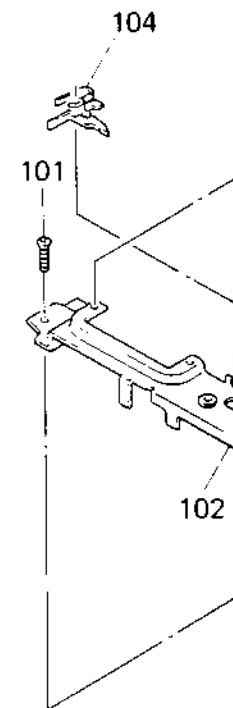

Ref.No	Part No.	Description	Remarks
101	7-627-452-58	SCREW, PRECISION +P 1.7X2.5	
102	*3-351-254-01	BRACKET (COUNTER)	
104	3-351-253-01	LEVER, SAFETY	
105	3-345-814-01	BELT	
106	3-303-809-51	BUSHING	
107	3-351-230-01	PULLEY (MIDWAY)	
108	3-831-441-11	BELT	
109	7-627-552-77	SCREW, PRECISION +P 2X3 TYPE 3	
110	3-349-752-01	ARM ASSY, FR	
111	3-343-340-01	LEVER (P) ASSY, JOINT	
112	3-343-339-01	LEVER, SAFETY	
113	3-351-250-04	SPRING, TENSION	
114	3-343-346-01	LEVER (FR)	
115	3-351-259-01	SPRING, TENSION	
116	3-351-283-01	SCREW (M1.6X3.8)	
117	3-342-034-01	SPACER	

SECTION 7
ELECTRICAL PARTS LIST

6-3. MECHANISM SECTION (2)
(MT-2000-61)

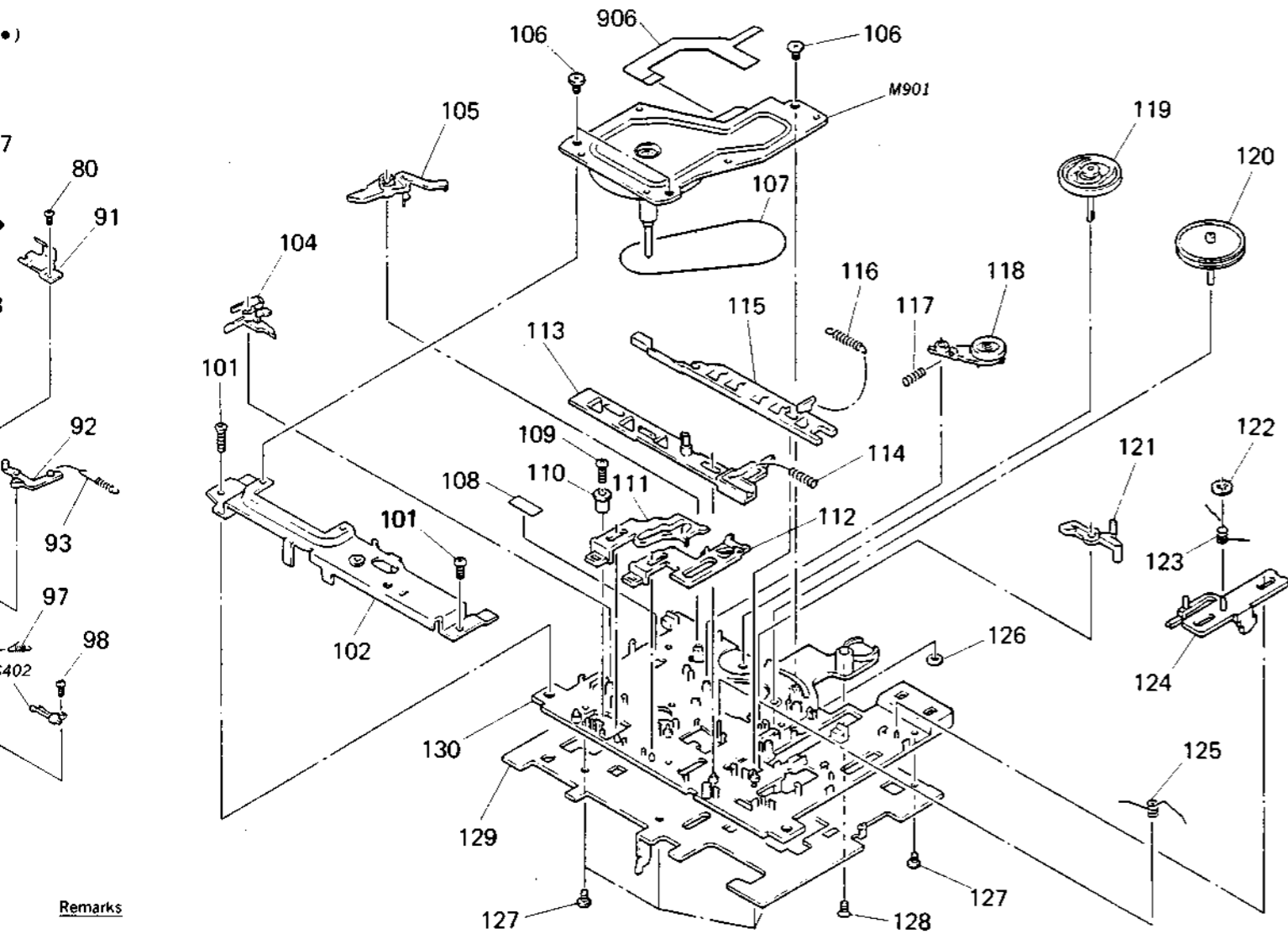

Ref.No	Part No.	Description	Remarks	Ref.No	Part No.	Description	Remarks
101	7-627-452-58	SCREW +K 2X6 TYPE1		118	X-3343-337-1	ARM ASSY. IDLER	
102	*3-351-254-01	BRACKET (MOTOR)		119	X-3343-307-1	PLATE ASSY. T REEL	
104	3-351-253-01	LEVER (B). SHUT-OFF		120	X-3351-209-1	PULLEY ASSY. MIDWAY	
105	3-345-814-01	LEVER (S). SHAFT OFF		121	3-342-010-01	ARM. CR	
106	3-303-809-51	SCREW (M1.7X5.0), SPECIAL HEAD		122	3-342-841-01	NUT, F PUSH	
107	3-351-230-01	BELT		123	3-351-274-01	SPRING, TORSION	
108	3-831-441-11	CUSHION (B)		124	3-351-238-01	SLIDER, EJECT	
109	7-627-552-77	SCREW, PRECISION +P 1.7X6		125	3-342-035-01	SPRING (FR)	
110	3-349-752-01	SPACER (FF)		126	3-570-615-00	POLY-WASHER (DIA. 1.2)	
111	3-343-340-01	LEVER, FF		127	3-343-254-51	SCREW (B1.7X2.8), TAPPING	
112	3-343-339-01	LEVER, REW		128	3-351-279-01	SCREW (M1.7), TAPPING	
113	3-351-250-04	SLIDER, POWER		129	*X-3351-211-1	PLATE ASSY. B	
114	3-343-346-01	SPRING, COMPRESSION		130	3-351-268-01	BRACKET, LEVER	
115	3-351-259-01	SLIDER, LOCK		906	1-630-106-11	PC BOARD, MOTOR FLEXIBLE	
116	3-351-283-01	SPRING, TENSION		M901	1-541-656-11	MOTOR (FWD)	
117	3-342-034-01	SPRING, TENSION					

NOTE:

- Due to standardization, replacements in the parts list may be different from the parts specified in the diagrams or the components used on the set.
- Items marked "*" are not stocked since they are seldom required for routine service. Some delay should be anticipated when ordering these items.
- If there are two or more same circuits in a set such as a stereophonic machine, only typical circuit parts may be indicated and capacitors and resistors in other same circuits may be omitted.

CAPACITORS:
MF: μ F, PF: μ F.

RESISTORS
• All resistors are in ohms.
• F: nonflammable

COILS
• MMH: mH, UH: μ H

SEMICONDUCTORS
In each case, U: μ , for example:
UA...: μ A..., UPA...: μ PA...,
UPC...: μ PC, UPD...: μ PD...

Ref.No	Part No.	Description	Ref.No	Part No.	Description
901	*1-629-354-11	PC BOARD, SWITCH	C208	1-162-638-11	CERAMIC CHIP
902	1-629-355-11	PC BOARD, SWITCH FLEXIBLE	C209	1-124-778-00	ELECT CHIP
903	*A-3015-719-A	PC BOARD ASSY. MAIN	C210	1-126-193-11	ELECT CHIP
904	1-550-463-11	COUNTER, TAPE (ULTRA SMALL)	C211	1-126-193-11	ELECT CHIP
905	A-3133-368-A	MOTOR BLOCK ASSY (INCLUDING M902)	C212	1-164-161-11	CERAMIC CHIP
906	1-630-106-11	PC BOARD, MOTOR FLEXIBLE	C213	1-164-161-11	CERAMIC CHIP
CAPACITOR					
C101	1-163-810-00	CERAMIC CHIP	C214	1-163-117-00	CERAMIC CHIP
C102	1-124-778-00	ELECT CHIP	C215	1-163-015-00	CERAMIC CHIP
C103	1-126-193-11	ELECT CHIP	C216	1-124-779-00	ELECT CHIP
C104	1-126-193-11	ELECT CHIP	C217	1-163-015-00	CERAMIC CHIP
C105	1-126-191-11	ELECT CHIP	C218	1-163-015-00	CERAMIC CHIP
C106	1-124-779-00	ELECT CHIP	C219	1-163-017-00	CERAMIC CHIP
C107	1-126-193-11	ELECT CHIP	C220	1-126-196-11	ELECT CHIP
C108	1-162-638-11	CERAMIC CHIP	C221	1-126-191-11	ELECT CHIP
C109	1-124-778-00	ELECT CHIP	C222	1-126-191-11	ELECT CHIP
C110	1-126-193-11	ELECT CHIP	C223	1-126-196-11	ELECT CHIP
C111	1-126-193-11	ELECT CHIP	C224	1-163-019-00	CERAMIC CHIP
C112	1-164-161-11	CERAMIC CHIP	C225	1-163-810-00	CERAMIC CHIP
C113	1-164-161-11	CERAMIC CHIP	C226	1-163-809-11	CERAMIC CHIP
C114	1-163-117-00	CERAMIC CHIP	C227	1-126-192-11	ELECT CHIP
C115	1-163-015-00	CERAMIC CHIP	C228	1-163-017-00	CERAMIC CHIP
C116	1-124-779-00	ELECT CHIP	C229	1-126-191-11	ELECT CHIP
C117	1-163-015-00	CERAMIC CHIP	C230	1-163-810-00	CERAMIC CHIP
C118	1-163-015-00	CERAMIC CHIP	C231	1-126-207-11	ELECT CHIP
C119	1-163-017-00	CERAMIC CHIP	C232	1-126-246-11	ELECT CHIP
C120	1-126-196-11	ELECT CHIP	C233	1-163-038-00	CERAMIC CHIP
C121	1-135-145-11	TANTAL. CHIP	C234	1-163-038-00	CERAMIC CHIP
C122	1-126-191-11	ELECT CHIP	C235	1-163-135-00	CERAMIC CHIP
C123	1-126-196-11	ELECT CHIP	C236	1-163-009-11	CERAMIC CHIP
C124	1-163-019-00	CERAMIC CHIP	C237	1-163-015-00	CERAMIC CHIP
C125	1-163-810-00	CERAMIC CHIP	C238	1-163-810-00	CERAMIC CHIP
C126	1-163-809-11	CERAMIC CHIP	C239	1-164-005-11	CERAMIC CHIP
C127	1-126-192-11	ELECT CHIP	C301	1-126-209-11	ELECT CHIP
C128	1-163-017-00	CERAMIC CHIP	C302	1-126-208-11	ELECT CHIP
C129	1-126-191-11	ELECT CHIP	C303	1-124-779-00	ELECT CHIP
C130	1-163-810-00	CERAMIC CHIP	C304	1-126-246-11	ELECT CHIP
C131	1-126-207-11	ELECT CHIP	C305	1-126-208-11	ELECT CHIP
C132	1-126-246-11	ELECT CHIP	C306	1-163-038-00	CERAMIC CHIP
C133	1-163-038-00	CERAMIC CHIP	C307	1-126-208-11	ELECT CHIP
C134	1-163-038-00	CERAMIC CHIP	C308	1-163-038-00	CERAMIC CHIP
C135	1-163-135-00	CERAMIC CHIP	C309	1-163-038-00	CERAMIC CHIP
C136	1-163-009-11	CERAMIC CHIP	C310	1-124-779-00	ELECT CHIP
C137	1-163-015-00	CERAMIC CHIP	C311	1-126-207-11	ELECT CHIP
C138	1-163-810-00	CERAMIC CHIP	C312	1-126-193-11	ELECT CHIP
C139	1-164-005-11	CERAMIC CHIP	C313	1-124-472-11	ELECT
C201	1-163-810-00	CERAMIC CHIP	C314	1-126-196-11	ELECT CHIP
C202	1-124-778-00	ELECT CHIP	C315	1-164-222-11	CERAMIC CHIP
C203	1-126-193-11	ELECT CHIP	C316	1-126-207-11	ELECT CHIP
C204	1-126-193-11	ELECT CHIP	C317	1-126-190-	ELECT CHIP
C205	1-126-191-11	ELECT CHIP	C318	1-126-190-	ELECT CHIP
C206	1-124-779-00	ELECT CHIP	C319	1-126-190-	ELECT CHIP
C207	1-126-193-11	ELECT CHIP	C320	1-161-041-00	CERAMIC
			C321	1-163-009-11	CERAMIC CHIP
			C322	1-126-207-11	ELECT CHIP
			C323	1-126-193-11	ELECT CHIP

Ref.No	Part No.	Description			
C324	1-126-191-11	ELECT CHIP	0.47MF	20%	50V
C325	1-163-038-00	CERAMIC CHIP	0.1MF		25V
C326	1-163-021-00	CERAMIC CHIP	0.01MF	10%	50V
C327	1-124-778-00	ELECT CHIP	22MF	20%	6.3V
C328	1-163-117-00	CERAMIC CHIP	100PF	5%	50V
C329	1-163-117-00	CERAMIC CHIP	100PF	5%	50V
C401	1-126-193-11	ELECT CHIP	1MF	20%	50V
C402	1-164-222-11	CERAMIC CHIP	0.22MF		25V
C403	1-163-038-00	CERAMIC CHIP	0.1MF		25V
C404	1-163-038-00	CERAMIC CHIP	0.1MF		25V
C405	1-163-111-00	CERAMIC CHIP	56PF	5%	50V
C406	1-163-111-00	CERAMIC CHIP	56PF	5%	50V
C407	1-163-038-00	CERAMIC CHIP	0.1MF		25V
C408	1-124-779-00	ELECT CHIP	10MF	20%	16V
C409	1-126-208-11	ELECT CHIP	47MF	20%	4V
C410	1-163-111-00	CERAMIC CHIP	56PF	5%	50V
C411	1-163-038-00	CERAMIC CHIP	0.1MF		25V
C412	1-163-038-00	CERAMIC CHIP	0.1MF		25V
C413	1-124-779-00	ELECT CHIP	10MF	20%	16V
C414	1-163-117-00	CERAMIC CHIP	100PF	5%	50V
C415	1-126-191-11	ELECT CHIP	0.47MF	20%	50V
C416	1-163-038-00	CERAMIC CHIP	0.1MF		25V
C417	1-163-014-00	CERAMIC CHIP	0.0027MF	10%	50V
C418	1-163-145-00	CERAMIC CHIP	0.0015MF	10%	50V
C419	1-163-038-00	CERAMIC CHIP	0.1MF		25V
C420	1-163-038-00	CERAMIC CHIP	0.1MF		25V
C421	1-163-023-00	CERAMIC CHIP	0.015MF	10%	50V
C422	1-163-809-11	CERAMIC CHIP	0.047MF	10%	25V
C423	1-126-195-11	ELECT CHIP	2.2MF	20%	50V
C424	1-135-145-11	TANTAL CHIP	0.47MF	10%	35V
C425	1-163-809-11	CERAMIC CHIP	0.047MF	10%	25V
C426	1-124-779-00	ELECT CHIP	10MF	20%	16V
C427	1-135-148-21	TANTAL CHIP	1.5MF	10%	16V
C428	1-135-202-21	TANTAL CHIP	22MF	20%	6.3V
C429	1-126-209-11	ELECT CHIP	100MF	20%	4V
C430	1-126-193-11	ELECT CHIP	1MF	20%	50V
C431	1-126-206-11	ELECT CHIP	100MF	20%	6.3V
C432	1-126-208-11	ELECT CHIP	47MF	20%	4V
C433	1-126-193-11	ELECT CHIP	1MF	20%	50V
C434	1-163-038-00	CERAMIC CHIP	0.1MF		25V
C435	1-126-196-11	ELECT CHIP	3.3MF	20%	50V
C436	1-126-208-11	ELECT CHIP	47MF	20%	4V
C437	1-163-038-00	CERAMIC CHIP	0.1MF		25V
C438	1-163-021-00	CERAMIC CHIP	0.01MF	10%	50V
C439	1-163-037-11	CERAMIC CHIP	0.022MF	10%	25V
C440	1-164-222-11	CERAMIC CHIP	0.22MF		25V
C441	1-162-638-11	CERAMIC CHIP	1MF		16V
C442	1-162-638-11	CERAMIC CHIP	1MF		16V
C443	1-163-038-00	CERAMIC CHIP	0.1MF		25V
C444	1-163-038-00	CERAMIC CHIP	0.1MF		25V
C445	1-164-234-11	CERAMIC CHIP	1MF		10V
C446	1-164-234-11	CERAMIC CHIP	1MF		10V
C601	1-124-779-00	ELECT CHIP	10MF	20%	16V
C602	1-163-009-11	CERAMIC CHIP	0.001MF	10%	50V
C603	1-124-779-00	ELECT CHIP	10MF	20%	16V
C604	1-130-736-11	FILM	0.01MF	5%	50V
C605	1-163-810-00	CERAMIC CHIP	0.03MF	10%	25V
C606	1-163-021-00	CERAMIC CHIP	0.01MF	10%	50V
C607	1-163-021-00	CERAMIC CHIP	0.01MF	10%	50V
C608	1-163-009-11	CERAMIC CHIP	0.001MF	10%	50V
C609	1-163-021-00	CERAMIC CHIP	0.01MF	10%	50V
C610	1-163-810-00	CERAMIC CHIP	0.03MF	10%	25V
C611	1-163-021-00	CERAMIC CHIP	0.01MF	10%	50V
CN301	1-562-961-11	JACK (DC IN 6V)			
CN302	1-566-683-11	HOUSING, CONNECTOR (FPC) 10P			

Ref.No	Part No.	Description			
CN303	1-565-180-21	HOUSING, CONNECTOR 12P			
CN304	*1-566-001-11	PIN, CONNECTOR (PC BOARD) 4P			
CN305	*1-506-984-11	PIN, CONNECTOR (PC BOARD) 2P			
D301	8-719-800-76	DIODE 1SS226			
D302	8-719-800-76	DIODE 1SS226			
D303	8-719-800-76	DIODE 1SS226			
D304	8-719-100-05	DIODE 1S2837			
D401	8-719-800-76	DIODE 1SS226			
D402	8-719-800-76	DIODE 1SS226			
D403	8-719-100-05	DIODE 1S2837			
D404	8-719-100-05	DIODE 1S2837			
D405	8-719-100-05	DIODE 1S2837			
D406	8-719-100-05	DIODE 1S2837			
D407	8-719-100-05	DIODE 1S2837			
D408	8-719-100-05	DIODE 1S2837			
D409	8-719-908-30	DIODE DA106K			
D410	8-719-100-05	DIODE 1S2837			
D412	8-719-800-76	DIODE 1SS226			
D413	8-719-800-76	DIODE 1SS226			
D414	8-719-800-76	DIODE 1SS226			
D415	8-719-800-76	DIODE 1SS226			
D416	8-719-100-05	DIODE 1S2837			
D601	8-719-800-76	DIODE 1SS226			
D602	8-719-800-76	DIODE 1SS226			
D603	8-719-100-05	DIODE 1S2837			
D604	8-719-800-76	DIODE 1SS226			
D901	8-719-938-11	DIODE SLP151B-60			
D902	8-719-902-51	DIODE SLP251B			
D903	8-719-902-51	DIODE SLP251B			
HE901	1-543-474-11	HEAD, MAGNETIC (ERASE)			
HRP901	1-543-526-11	HEAD, MAGNETIC (REC/PB)			
IC301	8-759-403-67	IC AN7015S			
IC302	8-759-701-07	IC NJM2063AM			
IC303	8-759-701-02	IC NJM2073M			
IC401	8-759-106-23	IC UPD4066BG			
IC402	8-759-204-94	IC TC74HC00F			
IC403	8-759-972-70	IC BA3708F			
IC404	8-759-106-23	IC UPD4066BG			
IC405	8-759-106-23	IC UPD4066BG			
IC406	8-759-942-06	IC MB81464-12PD			
IC407	8-759-972-80	IC CXD1148AQ			
IC408	8-759-984-04	IC SC17700YNA			
IC601	8-759-106-92	IC UPD74HC161G			
IC602	8-759-909-45	IC CX20084			
IC603	8-759-802-28	IC LA5537			
IC604	8-759-106-23	IC UPD4066BG			
J301	1-507-999-11	JACK (MIC)			
J302	1-507-958-31	JACK (PHONES)			
J401	1-507-933-11	JACK (REMOTE)			
JR1	1-216-295-00	METAL GLAZE	0	5%	1/10W
JR2	1-216-295-00	METAL GLAZE	0	5%	1/10W
JR3	1-216-295-00	METAL GLAZE	0	5%	1/10W
JR4	1-216-295-00	METAL GLAZE	0	5%	1/10W
JR5	1-216-295-00	METAL GLAZE	0	5%	1/10W
JR6	1-216-295-00	METAL GLAZE	0	5%	1/10W
JR7	1-216-295-00	METAL GLAZE	0	5%	1/10W
JR10	1-216-296-00	METAL GLAZE	0	5%	1/8W
JR11	1-216-296-00	METAL GLAZE	0	5%	1/8W
JR12	1-216-296-00	METAL GLAZE	0	5%	1/8W
JR13	1-216-296-00	METAL GLAZE	0	5%	1/8W
L101	1-410-220-31	INDUCTOR CHIP 220UH			
L201	1-410-220-31	INDUCTOR CHIP 220UH			

Ref.No	Part No.	Description
L401	1-410-201-51	INDUCTOR CHIP 5.6UH
M901	1-541-656-11	MOTOR (FWD)
MIC901	1-542-092-11	MICROPHONE, ELECTRET CONDENSER
MIC902	1-542-092-11	MICROPHONE, ELECTRET CONDENSER
PH101	8-719-751-42	DIODE NJL5141E-AA
Q301	8-729-902-93	TRANSISTOR FMG4
Q302	8-729-903-30	TRANSISTOR DTC144TK
Q303	8-729-903-30	TRANSISTOR DTC144TK
Q304	8-729-402-81	TRANSISTOR XN4501
Q305	8-729-402-81	TRANSISTOR XN4501
Q306	8-729-902-93	TRANSISTOR FMG4
Q307	8-729-402-81	TRANSISTOR XN4501
Q308	8-729-903-10	TRANSISTOR FMW1
Q309	8-729-216-22	TRANSISTOR 2SA1162
Q310	8-729-903-30	TRANSISTOR DTC144TK
Q311	8-729-100-66	TRANSISTOR 2SC1623
Q312	8-729-100-66	TRANSISTOR 2SC1623
Q313	8-729-159-64	TRANSISTOR 2SD596
Q314	8-729-100-66	TRANSISTOR 2SC1623
Q315	8-729-402-81	TRANSISTOR XN4501
Q316	8-729-902-93	TRANSISTOR FMG4
Q401	8-729-162-44	TRANSISTOR 2SB624-BV4
Q402	8-729-100-66	TRANSISTOR 2SC1623
Q403	8-729-903-29	TRANSISTOR DTA144TK
Q404	8-729-903-29	TRANSISTOR DTA144TK
Q405	8-729-162-44	TRANSISTOR 2SB624-BV4
Q406	8-729-100-66	TRANSISTOR 2SC1623
Q407	8-729-100-66	TRANSISTOR 2SC1623
Q408	8-729-402-81	TRANSISTOR XN4501
Q409	8-729-100-66	TRANSISTOR 2SC1623
Q410	8-729-216-22	TRANSISTOR 2SA1162
Q411	8-729-903-30	TRANSISTOR DTC144TK
Q412	8-729-162-44	TRANSISTOR 2SB624-BV4
Q413	8-729-100-66	TRANSISTOR 2SC1623
Q414	8-729-903-30	TRANSISTOR DTC144TK
Q415	8-729-100-66	TRANSISTOR 2SC1623
Q416	8-729-402-81	TRANSISTOR XN4501
Q417	8-729-100-66	TRANSISTOR 2SC1623
Q418	8-729-100-66	TRANSISTOR 2SC1623
Q419	8-729-100-66	TRANSISTOR 2SC1623
Q420	8-729-100-66	TRANSISTOR 2SC1623
Q421	8-729-216-22	TRANSISTOR 2SA1162
Q422	8-729-100-66	TRANSISTOR 2SC1623
Q423	8-729-100-66	TRANSISTOR 2SC1623
Q424	8-729-100-66	TRANSISTOR 2SC1623
Q425	8-729-901-46	TRANSISTOR DTA114YK
Q426	8-729-900-52	TRANSISTOR DTC114YK
Q427	8-729-900-52	TRANSISTOR DTC114YK
Q428	8-729-901-46	TRANSISTOR DTA114YK
Q429	8-729-900-52	TRANSISTOR DTC114YK
Q430	8-729-900-52	TRANSISTOR DTC114YK
Q431	8-729-100-66	TRANSISTOR 2SC1623
Q432	8-729-903-10	TRANSISTOR FMW1
Q601	8-729-216-22	TRANSISTOR 2SA1162
Q602	8-729-100-66	TRANSISTOR 2SC1623
Q603	8-729-100-66	TRANSISTOR 2SC1623
Q604	8-729-162-44	TRANSISTOR 2SB624-BV4
Q605	8-729-100-66	TRANSISTOR 2SC1623
Q606	8-729-216-22	TRANSISTOR 2SA1162
Q607	8-729-100-66	TRANSISTOR 2SC1623

RESISTOR

R102	1-216-049-00	METAL GLAZE	1K	5%	1/10W
------	--------------	-------------	----	----	-------

Ref.No	Part No.	Description			
R103	1-216-069-00	METAL GLAZE	6.8K	5%	1/10W
R104	1-216-057-00	METAL GLAZE	2.2K	5%	1/10W
R105	1-216-065-00	METAL GLAZE	4.7K	5%	1/10W
R106	1-216-037-00	METAL GLAZE	330	5%	1/10W
R107	1-216-097-00	METAL GLAZE	100K	5%	1/10W
R108	1-216-033-00	METAL GLAZE	220	5%	1/10W
R109	1-216-085-00	METAL GLAZE	33K	5%	1/10W
R110	1-216-105-00	METAL GLAZE	220K	5%	1/10W
R111	1-216-077-00	METAL GLAZE	15K	5%	1/10W
R112	1-216-113-00	METAL GLAZE	470K	5%	1/10W
R113	1-216-085-00	METAL GLAZE	33K	5%	1/10W
R114	1-216-117-00	METAL GLAZE	680K	5%	1/10W
R115	1-216-073-00	METAL GLAZE	10K	5%	1/10W
R116	1-216-103-00	METAL GLAZE	180K	5%	1/10W
R117	1-216-073-00	METAL GLAZE	10K	5%	1/10W
R118	1-216-037-00	METAL GLAZE	330	5%	1/10W
R119	1-216-105-00	METAL GLAZE	220K	5%	1/10W
R120	1-216-089-00	METAL GLAZE	47K	5%	1/10W
R121	1-216-073-00	METAL GLAZE	10K	5%	1/10W
R122	1-216-112-00	METAL GLAZE	430K	5%	1/10W
R123	1-216-061-00	METAL GLAZE	3.3K	5%	1/10W
R124	1-216-089-00	METAL GLAZE	47K	5%	1/10W
R125	1-216-057-00	METAL GLAZE	2.2K	5%	1/10W
R126	1-216-053-00	METAL GLAZE	1.5K	5%	1/10W
R127	1-216-053-00	METAL GLAZE	1.5K	5%	1/10W
R128	1-216-025-00	METAL GLAZE	100	5%	1/10W
R129	1-217-671-11	METAL GLAZE	1	5%	1/10W
R130	1-216-021-00	METAL GLAZE	68	5%	1/10W
R131	1-216-077-00	METAL GLAZE	15K	5%	1/10W
R132	1-216-065-00	METAL GLAZE	4.7K	5%	1/10W
R202	1-216-049-00	METAL GLAZE	1K	5%	1/10W
R203	1-216-069-00	METAL GLAZE	6.8K	5%	1/10W
R204	1-216-057-00	METAL GLAZE	2.2K	5%	1/10W
R205	1-216-065-00	METAL GLAZE	4.7K	5%	1/10W
R206	1-216-037-00	METAL GLAZE	330	5%	1/10W
R207	1-216-097-00	METAL GLAZE	100K	5%	1/10W
R208	1-216-033-00	METAL GLAZE	220	5%	1/10W
R209	1-216-085-00	METAL GLAZE	33K	5%	1/10W
R210	1-216-105-00	METAL GLAZE	220K	5%	1/10W
R211	1-216-077-00	METAL GLAZE	15K	5%	1/10W
R212	1-216-113-00	METAL GLAZE	470K	5%	1/10W
R213	1-216-085-00	METAL GLAZE	33K	5%	1/10W
R214	1-216-117-00	METAL GLAZE	680K	5%	1/10W
R215	1-216-073-00	METAL GLAZE	10K	5%	1/10W
R216	1-216-103-00	METAL GLAZE	180K	5%	1/10W
R217	1-216-073-00	METAL GLAZE	10K	5%	1/10W
R218	1-216-037-00	METAL GLAZE	330	5%	1/10W
R219	1-216-105-00	METAL GLAZE	220K	5%	1/10W
R220	1-216-089-00	METAL GLAZE	47K	5%	1/10W
R221	1-216-073-00	METAL GLAZE	10K	5%	1/10W
R222	1-216-112-00	METAL GLAZE	430K	5%	1/10W
R223	1-216-061-00	METAL GLAZE	3.3K	5%	1/10W
R224	1-216-089-00	METAL GLAZE	47K	5%	1/10W
R225	1-216-057-00	METAL GLAZE	2.2K	5%	1/10W
R226	1-216-053-00	METAL GLAZE	1.5K	5%	1/10W
R227	1-216-053-00	METAL GLAZE	1.5K	5%	1/10W
R228	1-216-025-00	METAL GLAZE	100	5%	1/10W
R229	1-217-671-11	METAL GLAZE	1	5%	1/10W
R230	1-216-021-00	METAL GLAZE	68	5%	1/10W
R231	1-216-077-00	METAL GLAZE	15K	5%	1/10W
R232	1-216-065-00	METAL GLAZE	4.7K	5%	1/10W
R301	1-216-049-00	METAL GLAZE	1K	5%	1/10W
R302	1-216-073-00	METAL GLAZE	10K	5%	1/10W
R303	1-216-121-00	METAL GLAZE	1M	5%	1/10W
R304	1-216-105-00	METAL GLAZE	220K	5%	1/10W

Ref.No	Part No.	Description				Ref.No	Part No.	Description			
R305	1-216-085-00	METAL GLAZE	33K	5%	1/10W	R435	1-216-097-00	METAL GLAZE	100K	5%	1/10W
R306	1-216-065-00	METAL GLAZE	4.7K	5%	1/10W	R436	1-216-097-00	METAL GLAZE	100K	5%	1/10W
R307	1-216-039-00	METAL GLAZE	390	5%	1/10W	R437	1-216-105-00	METAL GLAZE	220K	5%	1/10W
R308	1-216-121-00	METAL GLAZE	1M	5%	1/10W	R438	1-216-105-00	METAL GLAZE	220K	5%	1/10W
R309	1-216-025-00	METAL GLAZE	100	5%	1/10W	R439	1-216-097-00	METAL GLAZE	100K	5%	1/10W
R310	1-216-057-00	METAL GLAZE	2.2K	5%	1/10W	R440	1-216-109-00	METAL GLAZE	330K	5%	1/10W
R311	1-216-065-00	METAL GLAZE	4.7K	5%	1/10W	R441	1-216-049-00	METAL GLAZE	1K	5%	1/10W
R312	1-216-089-00	METAL GLAZE	47K	5%	1/10W	R442	1-216-109-00	METAL GLAZE	330K	5%	1/10W
R313	1-216-095-00	METAL GLAZE	82K	5%	1/10W	R443	1-216-089-00	METAL GLAZE	47K	5%	1/10W
R314	1-216-079-00	METAL GLAZE	18K	5%	1/10W	R444	1-216-079-00	METAL GLAZE	18K	5%	1/10W
R315	1-216-081-00	METAL GLAZE	22K	5%	1/10W	R445	1-216-082-00	METAL GLAZE	24K	5%	1/10W
R316	1-216-049-00	METAL GLAZE	1K	5%	1/10W	R446	1-216-049-00	METAL GLAZE	1K	5%	1/10W
R317	1-216-103-00	METAL GLAZE	180K	5%	1/10W	R447	1-216-117-00	METAL GLAZE	680K	5%	1/10W
R318	1-216-065-00	METAL GLAZE	4.7K	5%	1/10W	R448	1-216-089-00	METAL GLAZE	47K	5%	1/10W
R319	1-216-105-00	METAL GLAZE	220K	5%	1/10W	R449	1-216-081-00	METAL GLAZE	22K	5%	1/10W
R320	1-216-059-00	METAL GLAZE	2.7K	5%	1/10W	R450	1-216-065-00	METAL GLAZE	4.7K	5%	1/10W
R321	1-216-013-00	METAL GLAZE	33	5%	1/10W	R451	1-216-089-00	METAL GLAZE	47K	5%	1/10W
R322	1-216-109-00	METAL GLAZE	330K	5%	1/10W	R452	1-216-109-00	METAL GLAZE	330K	5%	1/10W
R323	1-216-074-00	METAL GLAZE	11K	5%	1/10W	R453	1-216-097-00	METAL GLAZE	100K	5%	1/10W
R324	1-216-074-00	METAL GLAZE	11K	5%	1/10W	R454	1-216-025-00	METAL GLAZE	100	5%	1/10W
R325	1-216-029-00	METAL GLAZE	150	5%	1/10W	R455	1-216-109-00	METAL GLAZE	330K	5%	1/10W
R326	1-216-041-00	METAL GLAZE	470	5%	1/10W	R456	1-216-121-00	METAL GLAZE	1M	5%	1/10W
R327	1-216-073-00	METAL GLAZE	10K	5%	1/10W	R457	1-216-051-00	METAL GLAZE	1.2K	5%	1/10W
R328	1-216-065-00	METAL GLAZE	4.7K	5%	1/10W	R458	1-216-073-00	METAL GLAZE	10K	5%	1/10W
R329	1-216-097-00	METAL GLAZE	100K	5%	1/10W	R459	1-216-105-00	METAL GLAZE	220K	5%	1/10W
R330	1-216-097-00	METAL GLAZE	100K	5%	1/10W	R460	1-216-045-00	METAL GLAZE	680	5%	1/10W
R331	1-216-009-00	METAL GLAZE	22	5%	1/10W	R461	1-216-101-00	METAL GLAZE	150K	5%	1/10W
R332	1-216-081-00	METAL GLAZE	22K	5%	1/10W	R462	1-216-113-00	METAL GLAZE	470K	5%	1/10W
R333	1-216-097-00	METAL GLAZE	100K	5%	1/10W	R463	1-216-049-00	METAL GLAZE	1K	5%	1/10W
R334	1-216-049-00	METAL GLAZE	1K	5%	1/10W	R464	1-216-113-00	METAL GLAZE	470K	5%	1/10W
R335	1-216-035-00	METAL GLAZE	270	5%	1/10W	R465	1-216-113-00	METAL GLAZE	470K	5%	1/10W
R401	1-216-121-00	METAL GLAZE	1M	5%	1/10W	R466	1-216-105-00	METAL GLAZE	220K	5%	1/10W
R402	1-216-065-00	METAL GLAZE	4.7K	5%	1/10W	R467	1-216-101-00	METAL GLAZE	150K	5%	1/10W
R403	1-216-065-00	METAL GLAZE	4.7K	5%	1/10W	R468	1-216-089-00	METAL GLAZE	47K	5%	1/10W
R404	1-216-073-00	METAL GLAZE	10K	5%	1/10W	R469	1-216-025-00	METAL GLAZE	100	5%	1/10W
R405	1-216-089-00	METAL GLAZE	47K	5%	1/10W	R470	1-216-065-00	METAL GLAZE	4.7K	5%	1/10W
R406	1-216-073-00	METAL GLAZE	10K	5%	1/10W	R471	1-216-117-00	METAL GLAZE	680K	5%	1/10W
R407	1-216-073-00	METAL GLAZE	10K	5%	1/10W	R472	1-216-097-00	METAL GLAZE	100K	5%	1/10W
R408	1-216-097-00	METAL GLAZE	100K	5%	1/10W	R473	1-216-073-00	METAL GLAZE	10K	5%	1/10W
R409	1-216-073-00	METAL GLAZE	10K	5%	1/10W	R474	1-216-071-00	METAL GLAZE	8.2K	5%	1/10W
R410	1-216-073-00	METAL GLAZE	10K	5%	1/10W	R475	1-216-065-00	METAL GLAZE	4.7K	5%	1/10W
R411	1-216-117-00	METAL GLAZE	680K	5%	1/10W	R476	1-216-067-00	METAL GLAZE	5.6K	5%	1/10W
R412	1-216-109-00	METAL GLAZE	330K	5%	1/10W	R477	1-216-097-00	METAL GLAZE	100K	5%	1/10W
R413	1-216-089-00	METAL GLAZE	47K	5%	1/10W	R478	1-216-073-00	METAL GLAZE	10K	5%	1/10W
R414	1-216-033-00	METAL GLAZE	220	5%	1/10W	R479	1-216-113-00	METAL GLAZE	470K	5%	1/10W
R415	1-216-033-00	METAL GLAZE	220	5%	1/10W	R480	1-216-073-00	METAL GLAZE	10K	5%	1/10W
R416	1-216-089-00	METAL GLAZE	47K	5%	1/10W	R481	1-216-073-00	METAL GLAZE	10K	5%	1/10W
R417	1-216-089-00	METAL GLAZE	47K	5%	1/10W	R482	1-216-073-00	METAL GLAZE	10K	5%	1/10W
R418	1-216-089-00	METAL GLAZE	47K	5%	1/10W	R483	1-216-073-00	METAL GLAZE	10K	5%	1/10W
R419	1-216-109-00	METAL GLAZE	330K	5%	1/10W	R484	1-216-073-00	METAL GLAZE	10K	5%	1/10W
R420	1-216-113-00	METAL GLAZE	470K	5%	1/10W	R485	1-216-073-00	METAL GLAZE	10K	5%	1/10W
R421	1-216-073-00	METAL GLAZE	10K	5%	1/10W	R486	1-216-073-00	METAL GLAZE	10K	5%	1/10W
R422	1-216-073-00	METAL GLAZE	10K	5%	1/10W	R487	1-216-080-00	METAL GLAZE	20K	5%	1/10W
R423	1-216-103-00	METAL GLAZE	180K	5%	1/10W	R488	1-216-081-00	METAL GLAZE	22K	5%	1/10W
R424	1-216-057-00	METAL GLAZE	2.2K	5%	1/10W	R489	1-216-097-00	METAL GLAZE	100K	5%	1/10W
R425	1-216-073-00	METAL GLAZE	10K	5%	1/10W	R490	1-216-101-00	METAL GLAZE	150K	5%	1/10W
R426	1-216-073-00	METAL GLAZE	10K	5%	1/10W	R491	1-216-073-00	METAL GLAZE	10K	5%	1/10W
R427	1-216-097-00	METAL GLAZE	100K	5%	1/10W	R492	1-216-073-00	METAL GLAZE	10K	5%	1/10W
R428	1-216-065-00	METAL GLAZE	4.7K	5%	1/10W	R601	1-216-081-00	METAL GLAZE	22K	5%	1/10W
R429	1-216-073-00	METAL GLAZE	10K	5%	1/10W	R602	1-216-057-00	METAL GLAZE	2.2K	5%	1/10W
R430	1-216-115-00	METAL GLAZE	560K	5%	1/10W	R603	1-216-049-00	METAL GLAZE	1K	5%	1/10W
R431	1-216-097-00	METAL GLAZE	100K	5%	1/10W	R604	1-216-073-00	METAL GLAZE	10K	5%	1/10W
R432	1-216-073-00	METAL GLAZE	10K	5%	1/10W	R605	1-216-073-00	METAL GLAZE	10K	5%	1/10W
R433	1-216-009-00	METAL GLAZE	22	5%	1/10W	R606	1-216-073-00	METAL GLAZE	10K	5%	1/10W
R434	1-216-097-00	METAL GLAZE	100K	5%	1/10W	R607	1-216-097-00	METAL GLAZE	100K	5%	1/10W

Ref.No	Part No.	Description			
R608	1-216-073-00	METAL GLAZE	10K	5%	1/10W
R609	1-216-748-11	METAL GLAZE	39K	5%	1/10W
R610	1-216-097-00	METAL GLAZE	100K	5%	1/10W
R611	1-216-073-00	METAL GLAZE	10K	5%	1/10W
R612	1-216-089-00	METAL GLAZE	47K	5%	1/10W
R613	1-216-105-00	METAL GLAZE	220K	5%	1/10W
R614	1-216-081-00	METAL GLAZE	22K	5%	1/10W
R616	1-216-025-00	METAL GLAZE	100	5%	1/10W
R617	1-216-081-00	METAL GLAZE	22K	5%	1/10W
R618	1-216-081-00	METAL GLAZE	22K	5%	1/10W
R619	1-216-049-00	METAL GLAZE	1K	5%	1/10W
R620	1-216-117-00	METAL GLAZE	680K	5%	1/10W
R621	1-216-073-00	METAL GLAZE	10K	5%	1/10W
R622	1-216-097-00	METAL GLAZE	100K	5%	1/10W
R623	1-216-097-00	METAL GLAZE	100K	5%	1/10W
R624	1-216-097-00	METAL GLAZE	100K	5%	1/10W
RV101	1-228-358-00	RES. ADJ, METAL GLAZE	2.2K		
RV102	1-238-559-11	RES. ADJ, METAL GLAZE	500		
RV201	1-228-358-00	RES. ADJ, METAL GLAZE	2.2K		
RV202	1-238-559-11	RES. ADJ, METAL GLAZE	500		
RV301	1-230-687-11	RES. VAR, CARBON	10K/10K (VOLUME)		
RV601	1-238-522-11	RES. VAR, CARBON	47K (SPEED CONTROL)		
RV602	1-230-873-11	RES. ADJ, METAL GLAZE	47K		
S301	1-571-341-11	SWITCH, SLIDE (REC/PB)			
S302	1-554-222-00	SWITCH, SLIDE (NOISE REDUCTION)			
S303	1-554-222-00	SWITCH, SLIDE (TONE/MIC SENS)			
S401	1-570-395-11	SWITCH, LEAF (POWER)			
S402	1-571-348-11	SWITCH, LEAF (FF/REW)			
S901	1-554-303-21	SWITCH, KEY BOARD (CUE MARKER)			
S902	1-554-303-21	SWITCH, KEY BOARD (SOUND SCAN)			
S903	1-554-222-00	SWITCH, SLIDE (PAUSE)			
S904	1-554-222-00	SWITCH, SLIDE (AUTO STOP)			
SP901	1-544-118-11	SPEAKER			
T301	1-433-251-00	TRANSFORMER, BIAS OSCILLATOR			
X401	1-567-918-11	VIBRATOR, CERAMIC (4MHz)			

ACCESSORY & PACKING MATERIAL

3-342-380-01	SHEET, SPEED HOLE
* 3-351-284-01	CUSHION (UPPER)
* 3-351-285-01	CUSHION (LOWER)
* 3-351-288-01	(US)... INDIVIDUAL CARTON
* 3-351-289-01	(Canadian, AEP, UK, E)... INDIVIDUAL CARTON
3-351-296-01	CASE, CARRYING
3-703-468-11	BAG, POLYETHYLENE
3-786-870-11	(Canadian, AEP, UK, E)... MANUAL, INSTRUCTION (ENGLISH, FRENCH, SPANISH, PORTUGUESE)
3-786-870-21	(US)... MANUAL, INSTRUCTION (ENGLISH)
3-786-870-41	(AEP)... MANUAL, INSTRUCTION (GERMAN, DUTCH, SWEDISH, ITALIAN)