

TCS-300



*US Model
Serial No. 20,001 and later*

*AEP Model
UK Model
E Model*

STEREO CASSETTE-CORDER

SPECIFICATIONS

Recording System:	4-track 2-channel stereo	Power Consumption:	6 W ac with Sony AC Power Adaptor AC-9W 9 VA ac with Sony AC Power Adaptor AC-456C 10 W ac with Sony AC Power Adaptor AC-66 9 W ac with Sony AC Power Adaptor AC-15A 9.2 W ac (50 Hz) or 8.9 W (60 Hz) with Sony AC Power Adaptor AC-4A
Fast Winding Time:	Approx. 2 min. with Sony Cassette C-60	Battery Life:	Approx. 2.5 hours using Sony SUM-3S Super Batteries Approx. 6 hours using Eveready AM3 Alkaline Batteries
Frequency Response:	50 – 9,000 Hz	Dimensions:	Approx. 93(w) x 171(h) x 41(d) mm 3 ³ / ₄ (w) x 6 ³ / ₄ (h) x 1 ⁵ / ₈ (d) inches not including projecting parts and controls
Speaker:	Approx. 5 cm (2 inches) dia.	Weight:	Approx. 610 g (1 lb 5 ⁵ / ₈ oz) including batteries
Power Output:	360 mW (at 10 % harmonic distortion)		
Inputs:	Two microphone input jacks (minijack) sensitivity 0.2 mV (–72 dB) for low impedance microphone		
Outputs:	Two headphone jack (stereo minijack) rated output 0.245 V (–10 dB), at load impedance 32 Ω		
Power Requirements:	6 V dc, four batteries, size AA (IEC designation R6), or optional Sony BP-23 Rechargeable Battery Pack 120 V ac, 60 Hz with optional Sony AC Power Adaptor AC-9W (US model) 110 or 220 V ac, 50 Hz with optional AC Power Adaptor AC-456C available in European countries (AEP model) 220 V ac, 50 Hz with optional AC Power Adaptor AC-66 available in European countries (AEP model) 240 V ac, 50 Hz with optional AC Power Adaptor AC-15A available in the United Kingdom (UK model) 110, 120, 220 or 240 V ac, 50/60 Hz with optional Power Adaptor AC-4A available in other countries (E model) 12 V car battery with optional Sony Car Battery Cord DCC-127A		

0 dB = 0.775 V

SONY

SERVICE MANUAL

SECTION 2
DISASSEMBLY

• Follow the disassembly procedure in the numerical order given.

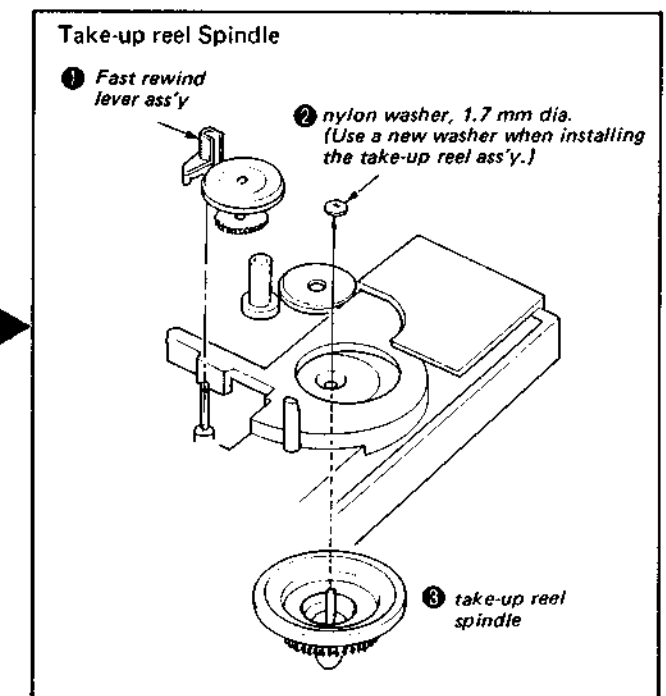
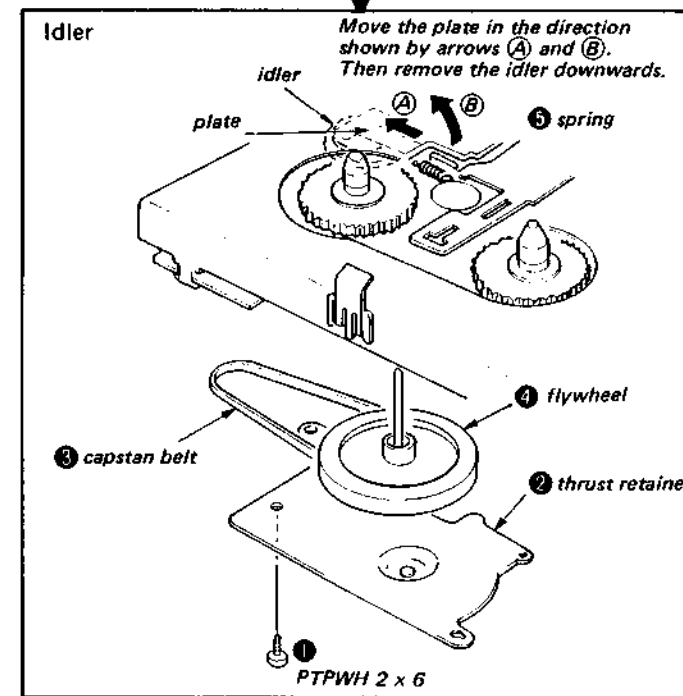
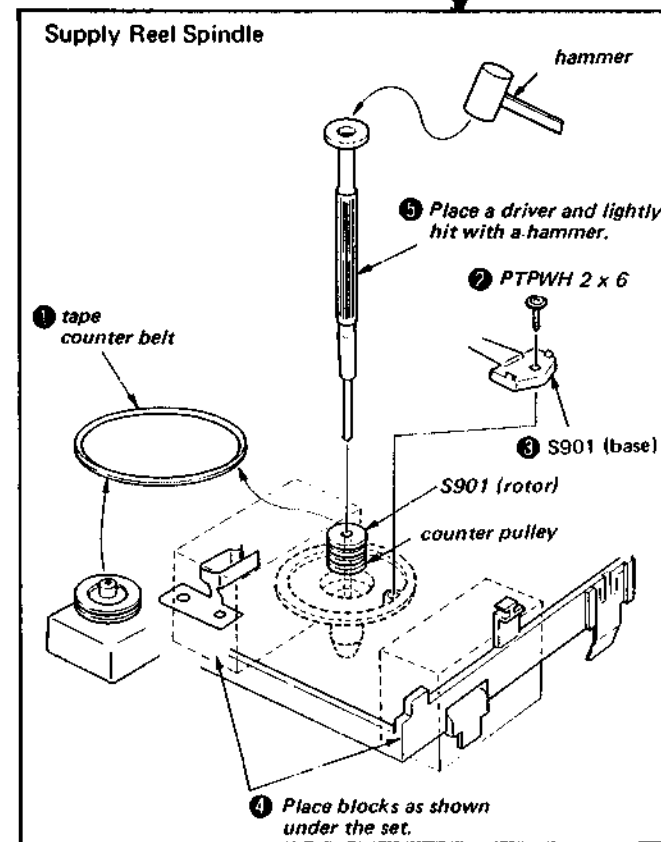
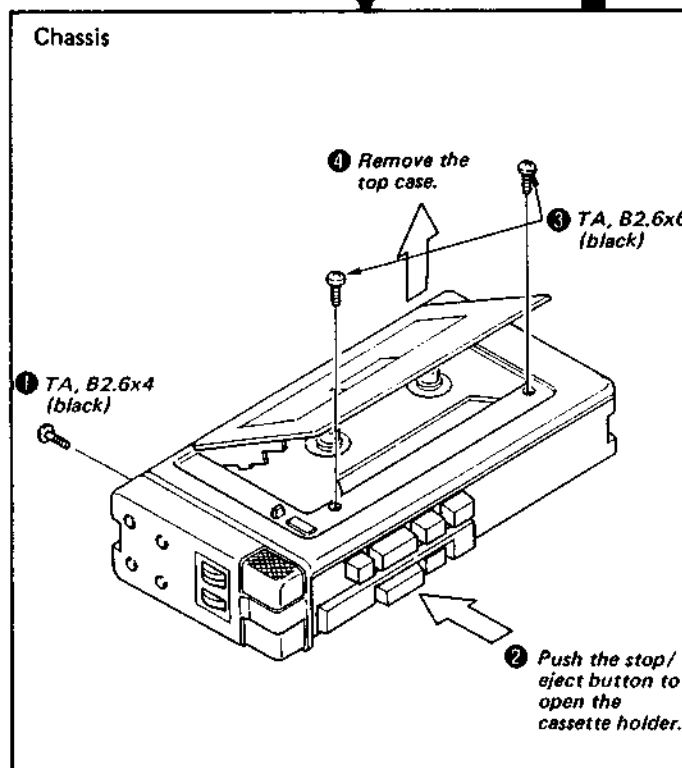
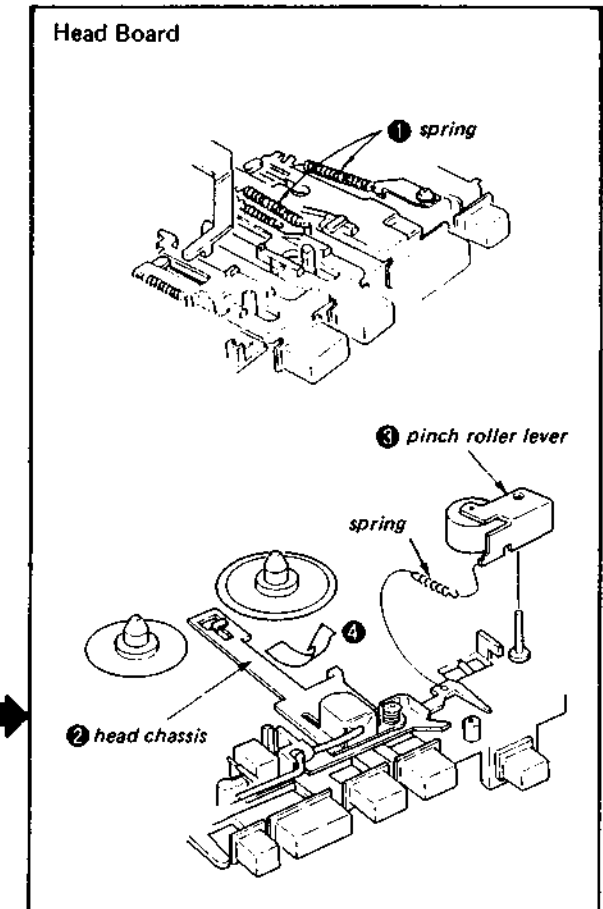
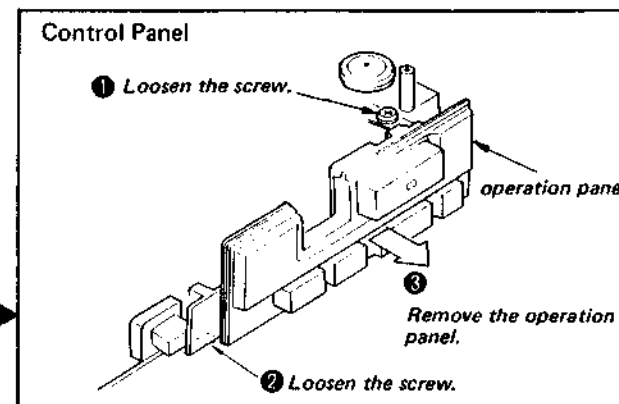
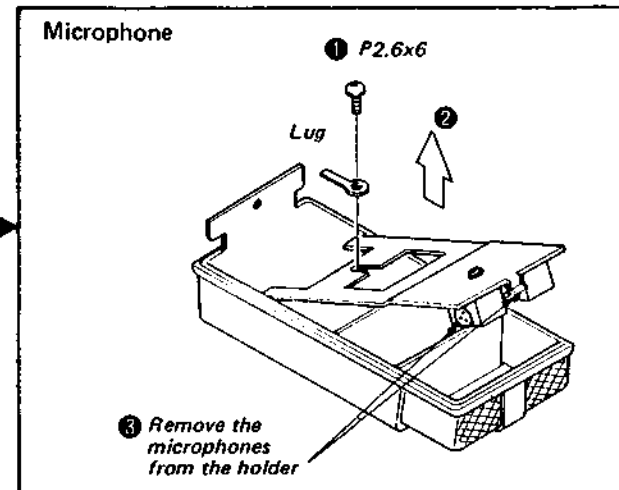
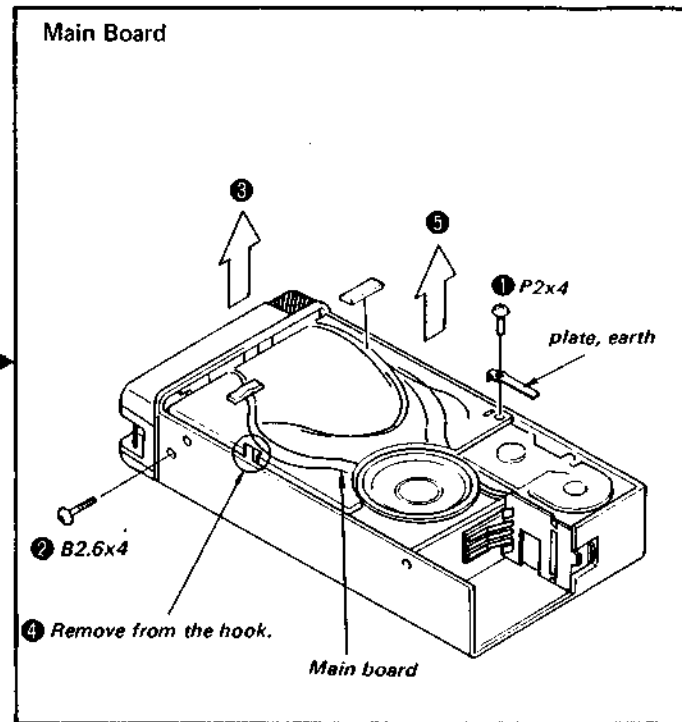
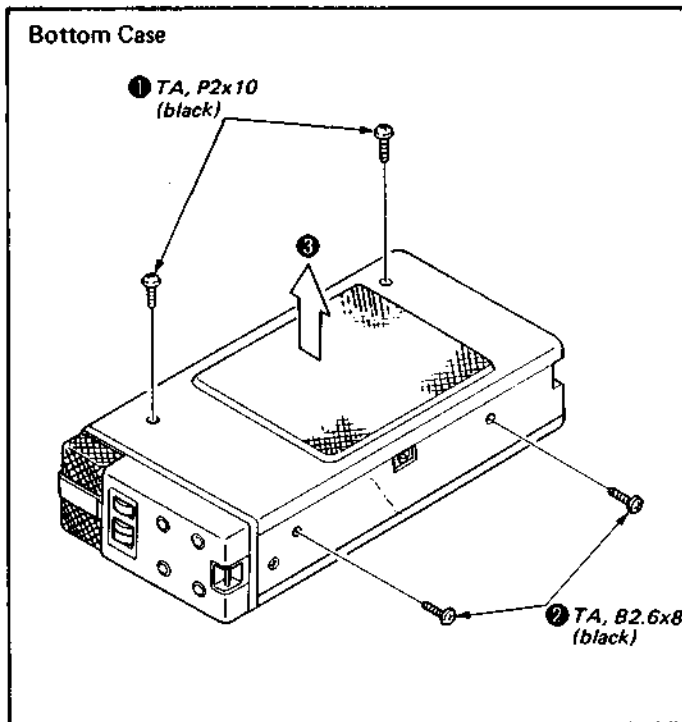

Remove the flywheel. Refer to the "Idler" removal.

SECTION 3
ADJUSTMENTS

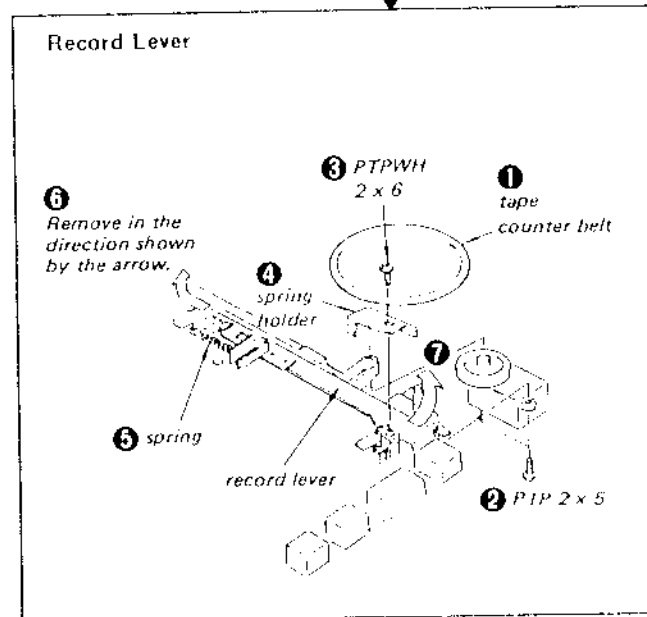
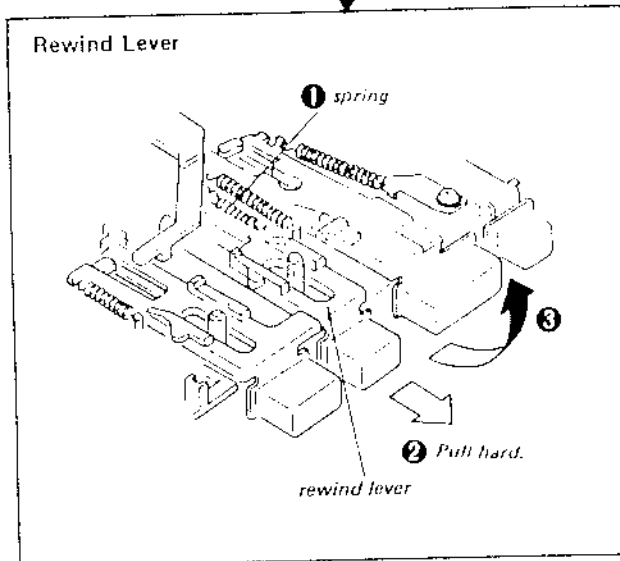
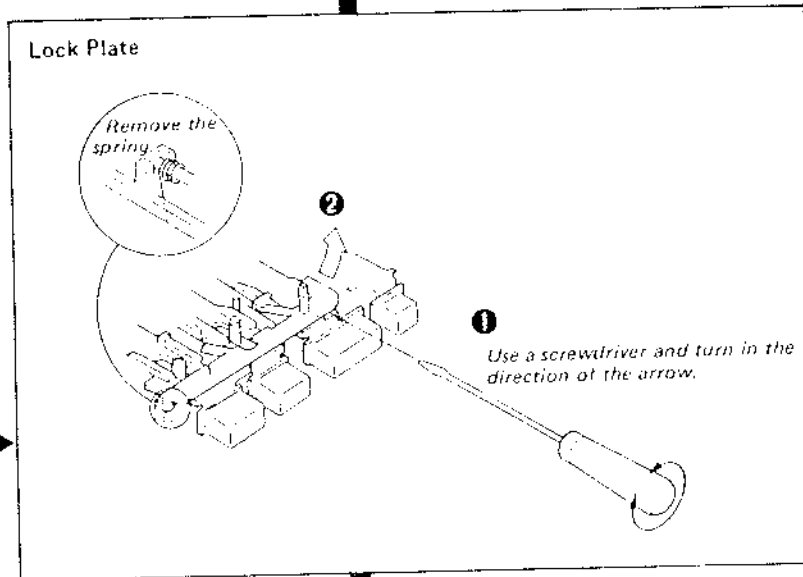
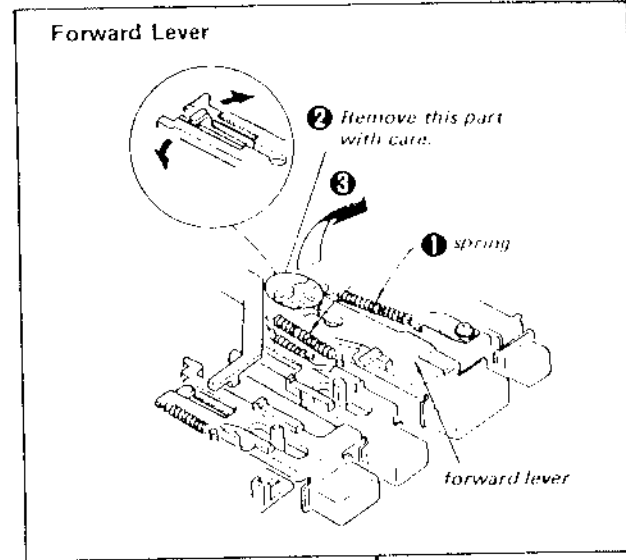
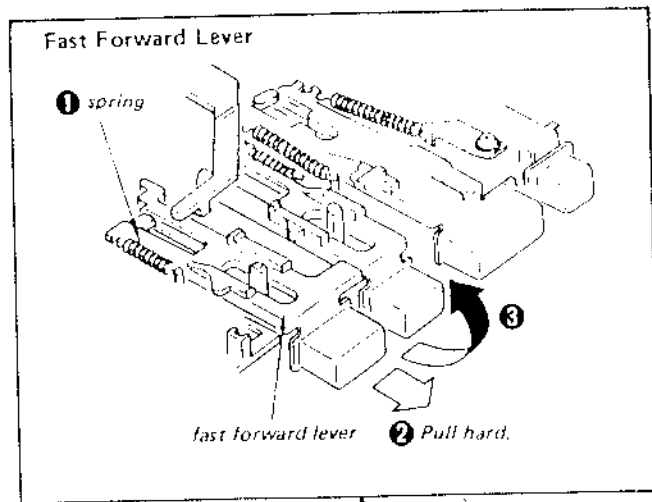

3-1. MECHANICAL ADJUSTMENTS

Torque Measurement

Torque	Torque Meter	Meter Reading
Forward	CQ-402C	24-50 g·cm (0.33-0.7 oz·inch)
Back Tension		less than 4.5 g·cm (0.63 oz·inch)
Fast Forward and Rewind	CQ-201B	more than 70 g·cm (0.97 oz·inch)

Tape Tension Measurement

Meter	Meter reading
CQ 403	more than 150 g (5.29 oz)

Flywheel Thrust Play Adjustment

— Playback Mode —

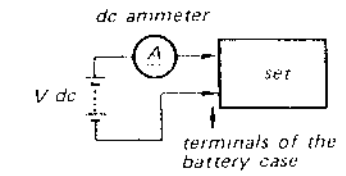

1. Turn the thrust screw counterclockwise until the screw tip leaves from the flywheel shaft.
2. Gradually turn the thrust screw clockwise to the position where the motor current suddenly increases.
3. Then, turn the thrust screw counterclockwise about 1/4 turn from the position obtained in step 2.

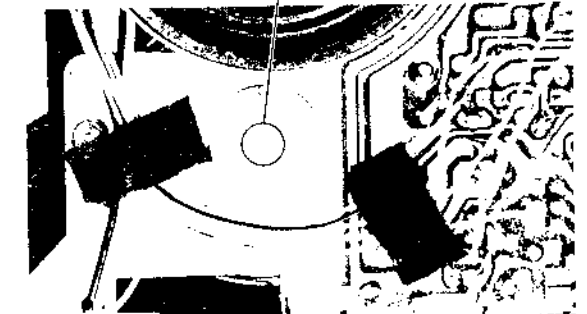
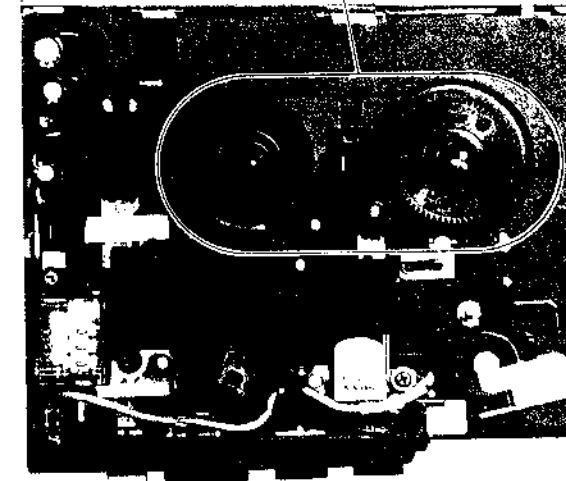

Head Height Adjustment

1. Prepare an adjustment cassette as shown below.

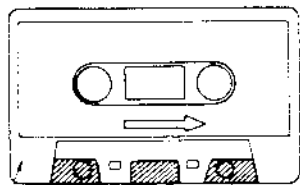

C-120
tape cassette

Cut out hatched
portions.

2. In playback mode and viewing from the front, adjust the head heights to eliminate tape curl and tape twist at arrowed portions.

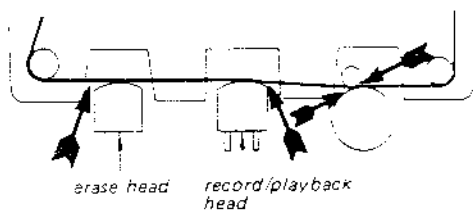

erase head

record/playback
head

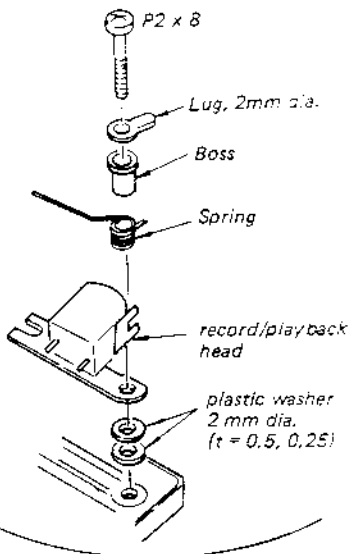

P2 x 8

Lug, 2mm dia.

Boss

Spring

record/playback
head

plastic washer
2 mm dia.
(t = 0.5, 0.25)

Adjustment Location:

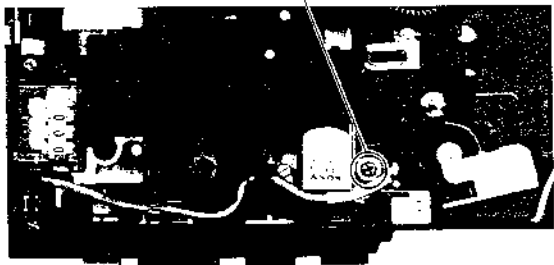

Pinch Roller Pressure Adjustment

— Playback Mode —

2. Slowly return the pinch roller and read the spring scale just when the pinch roller starts rotating. (The capstan should first contact here.)

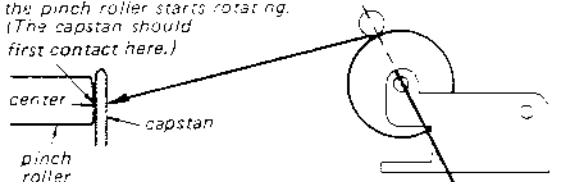

1 tension gauge

270—350 g
(9.52—12.34 oz)

If necessary, replace the spring.

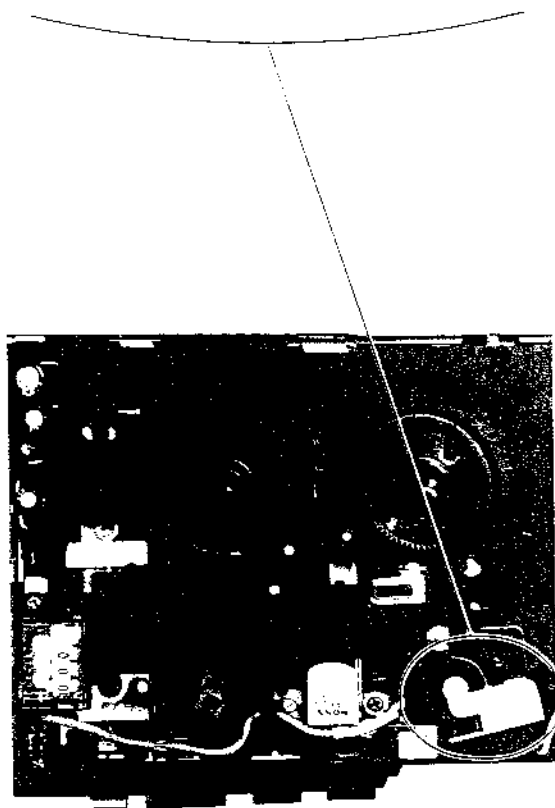

3-2. ELECTRICAL ADJUSTMENTS

Record/playback Head Azimuth Adjustment

Setting:

VOL Control: mechanical mid

Procedure:

1. Mode: playback

test tape
P-4-A81
(6.3 kHz, -10 dB)

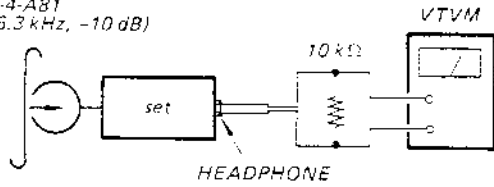

2. Turn the adjustment screw for maximum VTVM reading.

Note: Several peaks may appear, but take the maximum.

Adjustment Location:

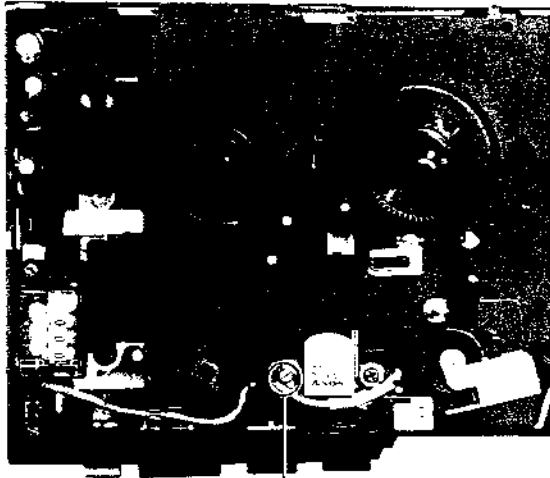

adjustment screw

Tape Speed Adjustment

Setting:

VOL Control: mechanical mid

Procedure:

- Mode: playback

test tape
WS-48
(3 kHz, 0 dB)

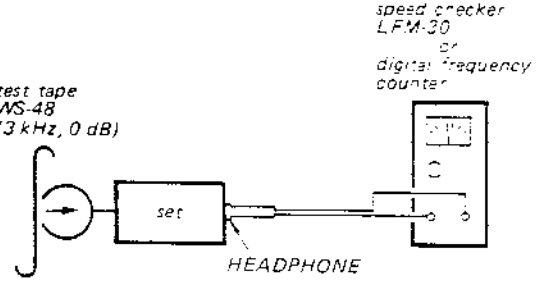

Adjust RVI so that the speed checker or the digital frequency counter reads 0 % or 2,985-3,000 Hz.

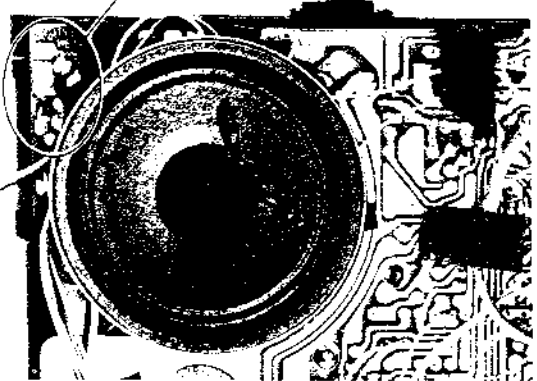

Pre-end Alarm Timing Adjustment

Apply 5.0 V dc power.

Procedure:

1. Playback the tape (C-60) from the beginning and stop it after 3 minutes.
2. Playback the other side of the cassette tape. Adjust RV301 so that D902 (PRE-END) starts lighting after 10 seconds.
3. If necessary, change the pattern connection and perform the adjustment again.

Pattern connection	Detection
no connection	faster
(A)	↑
(B)	↓
(A) and (B)	slower

Confirm that there is no tape curl or tape twist.

Note: D902 is designed to flicker in fast forward or rewind mode.

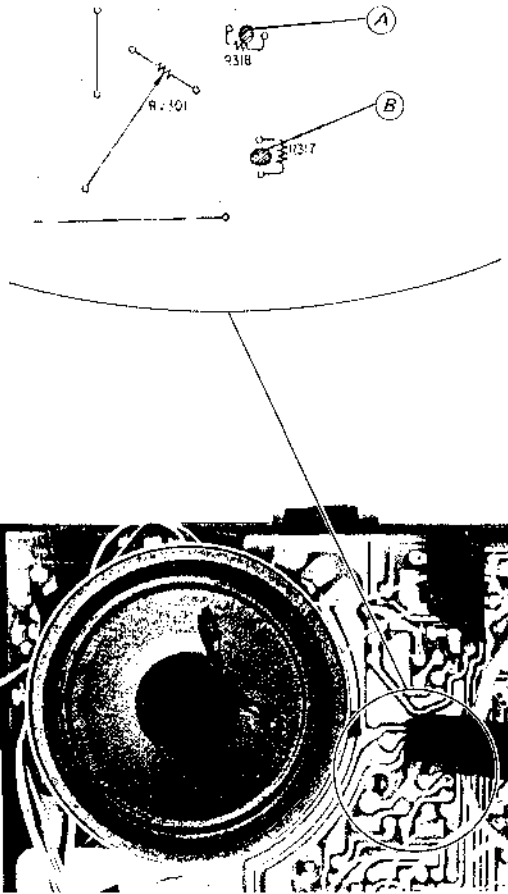

Record Bias Adjustment

Procedure:

1. Mode: record

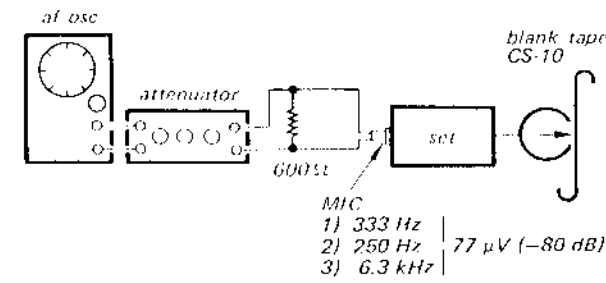

2. Mode: playback

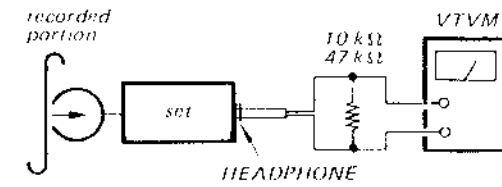

Record signal	VTVM reading
333 Hz	Adjust PB VOL control for 0.25 V (-10 dB)
250 Hz	Should be 0.17 V to 0.35 V (-10 dB to +3 dB)
6.3 kHz	

If necessary, adjust by changing the soldering portion as shown below and repeat steps 1 and 2.

Pattern Connection	High Frequency Level
(B)	up
(A)	↓
(A) and (B)	down

Adjustment Location:

- Main board -

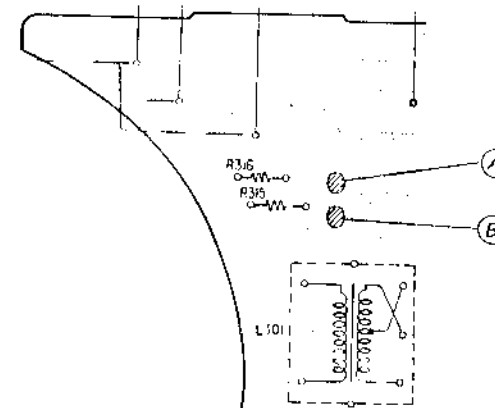

Microphone Sensitivity Adjustment

Connect pattern as follows.

Colour of the Mark (Built-in Microphone)	Pattern Connection
black	short
red	open

Adjustment Location:

- Input jack board -

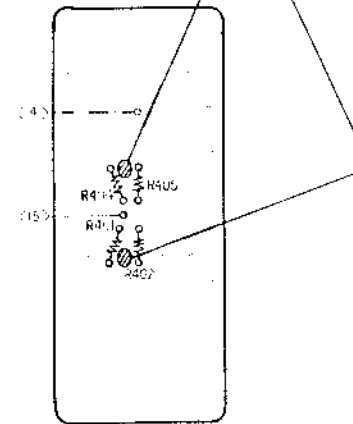

4-2. SCHEMATIC DIAGRAM

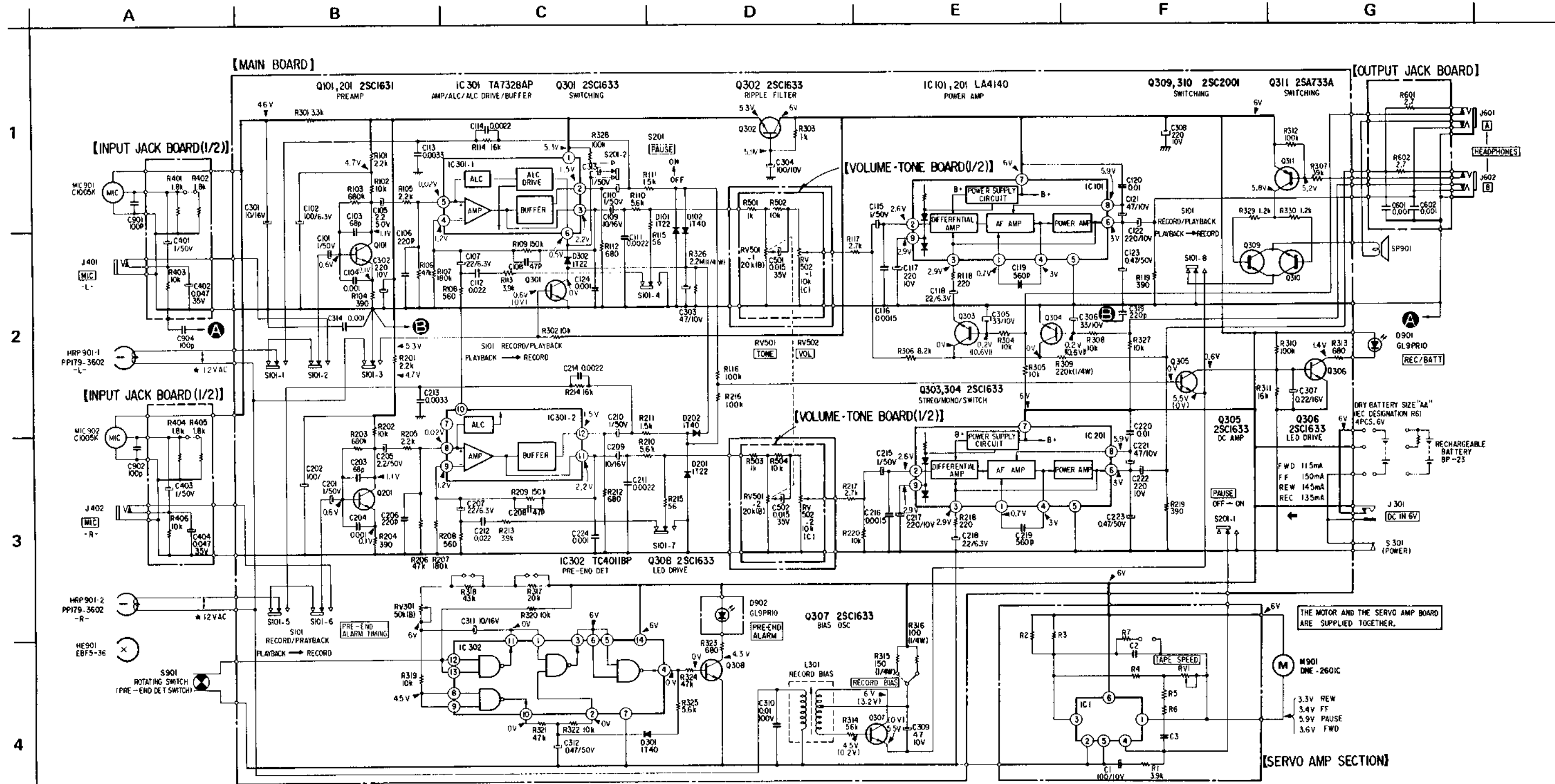

- Note:**
- All capacitors are in μF unless otherwise noted. $\text{pF} : \mu\text{F}$ 50WV or less are not indicated except for electrolytics and tantalums.
 - All resistors are in ohms, 1/8 W unless otherwise noted. $\text{k}\Omega : 1000 \Omega$, $\text{M}\Omega : 1000 \text{k}\Omega$
 - : panel designation.
 - : B+ bus.
 - : adjustment for repair.
 - Readings are taken under no-signal conditions with a VOM (20 $\text{k}\Omega/\text{V}$).
 - () : record mode
 - * : VTVM reading

Ref. No.	Switch	Position
S101	RECORD/PLAYBACK	PLAYBACK
S201	PAUSE	OFF
S301	POWER	OFF
S901	PRE-END DET	OFF

(3)

1
2
3
4
5

A B C

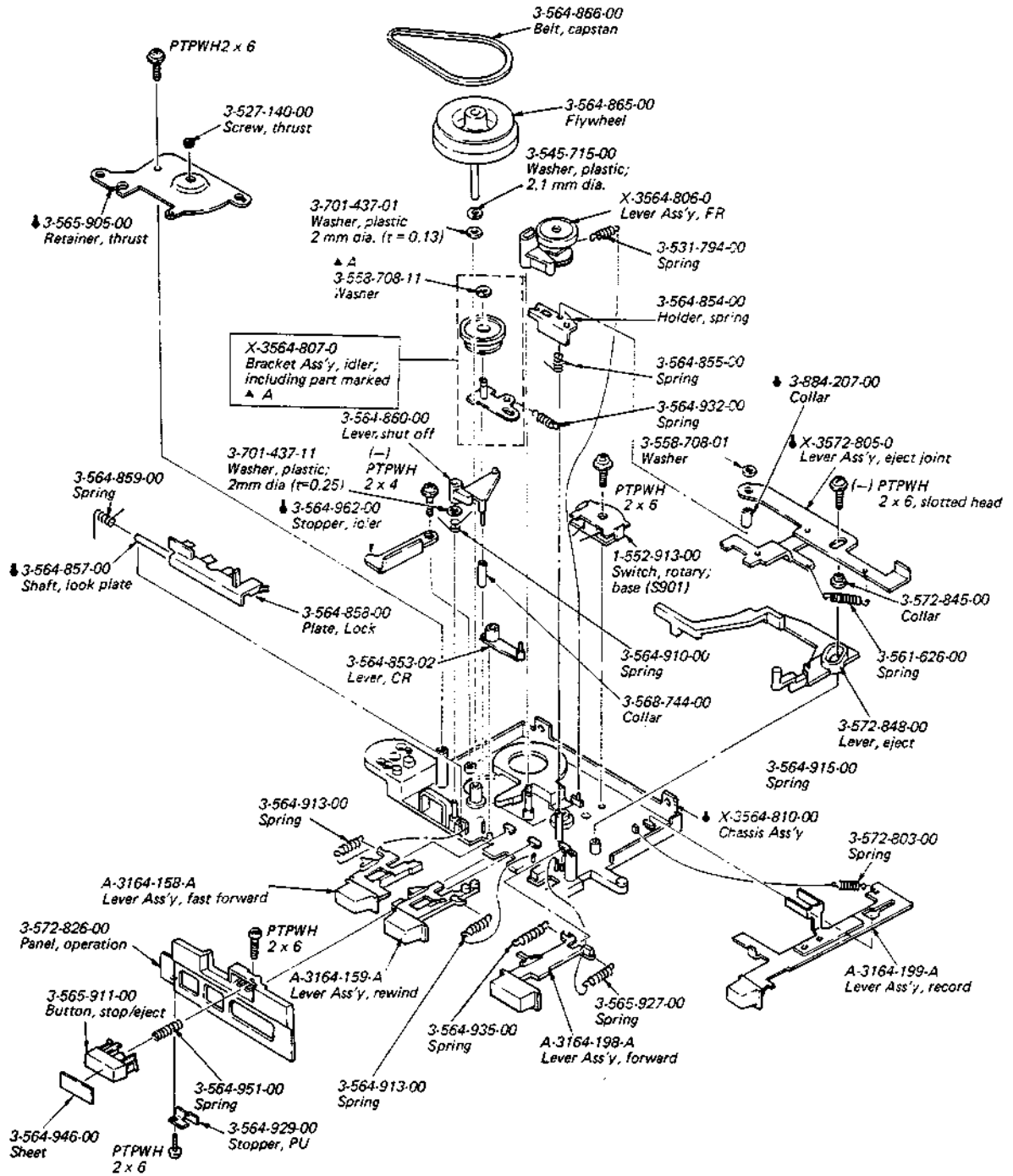

**SECTION 6
ELECTRICAL PARTS LIST**

Ref. No. Part No. Description

SEMICONDUCTORS

Transistors

Q101, 201	8-729-665-47	2SC1362
Q301, 302 Q304-308	8-729-663-47	2SC1364
Q309, 310	8-729-100-31	2SC2001
Q311	8-729-612-77	2SA1027R

ICs

IC101, 201	8-759-841-40	LA4140
IC301	8-759-273-28	TA7328AP
IC302	8-759-140-11	TC4011BP

Diodes

D101, 201	8-719-422-21	1T22AM
D102, 202 D301	8-719-815-55	1S1555
D302	8-719-422-21	1T22AM
D901, 902	8-719-909-10	GL9PR10

CAPACITORS

Common capacitors are omitted.
Refer to the lists on page 19 and 20 for their part numbers.

RESISTORS

All resistors are in ohms. Common 1/8 W carbon resistors are omitted. Refer to the list on page 21 for their part numbers.

R326	1-210-821-00	2.2 M ¼ W composition
RV301	1-226-238-00	50 k-B, adjustable; pre-end alarm
RV501	1-226-860-00	20 k/20 k-B, variable; TONE
RV502	1-226-859-00	10 k/10 k-C, variable; VOL

SWITCHES

S101	1-552-865-00	Slide, record/playback
S201	1-553-331-00	Pushbutton, PAUSE
S301	1-552-864-00	Leaf, power
S901	1-552-908-00	Rotary (rotor)
	1-552-913-00	Rotary (base)

• Items marked "♦" are not stocked since they are seldom required for routine service. Some delay should be anticipated when ordering these items.

Ref. No. Part No. Description

JACKS

J301	1-507-626-00	DC IN 6 V
J401 J402	1-507-562-00	MIC (L, R)
J601, 602	1-507-688-00	HEADPHONES

MISCELLANEOUS

HE901	8-658-096-02	Head, erase; EBF5-36
HRP901	8-829-373-01	Head, record/playback; PP179-3602
L301	1-433-206-00	Transformer, bias osc
M901	8-835-028-00	Motor (including servo amp section), DNE-2601C
MIC901 MIC902	8-814-197-80	Microphone, C1005K
SP901	1-502-810-00	Speaker 8 Ω

PRINTED CIRCUIT BOARDS

♦1-602-780-00	Input Jack
♦1-602-782-00	Volume/Tone
♦1-603-699-00	Main
♦1-603-700-00	Output Jack

ACCESSORIES & PACKING MATERIALS

<u>Part No.</u>	<u>Description</u>
1-506-400-00	Adaptor, plug (E model)
1-528-027-11	Battery, dry; SUM-3 (US, E model)
1-555-385-00	Cord, connection (RK-130) (AEP, UK, E model)
3-572-833-00	Cushion
3-572-849-00	Box, accessories
3-572-854-00	Belt, shoulder
3-572-855-00	Case, carrying (AEP, UK, E model)
3-572-860-00	Carton
3-572-861-00	Carton, headphone
3-701-624-00	Bag, plastic (for instruction manual)
3-783-195-11	Manual, instruction (AEP, UK model)
3-783-195-22	Manual, instruction (US model)
3-783-195-51	Manual, instruction (E model)
3-794-998-11	Manual, instruction; Cutch/Swedish (AEP model)
3-793-828-11	Card, caution (for cassette tape)
	Headphone, MDR-3L2 (AEP, UK model)
	Headphone, MDR-2L2 (US, E model)
8-893-521-10	Tape, demonstration; CD-810

ELECTROLYTIC CAPACITORS

CAP. (μF)	RATING → Use the high voltage rated one.											
	6.3 VOLT.		10 VOLT.		16 VOLT.		25 VOLT.		35 VOLT.		50 VOLT.	
	PART No.		PART No.		PART No.		PART No.		PART No.		PART No.	
0.47												1-121-726-00
1.0												1-121-391-00
2.2												1-121-450-00
3.3								1-121-392-00				1-121-393-00
4.7								1-121-395-00				1-121-396-00
10						1-121-651-00		1-121-398-00				1-121-738-00
22						1-121-479-00		1-121-480-00		1-121-662-00		1-121-152-00
33						1-121-403-00		1-121-404-00		1-121-652-00		1-121-405-00
47			1-121-352-00			1-121-409-00		1-121-410-00		1-121-653-00		1-121-411-00
100			1-121-414-00			1-121-415-00		1-121-416-00		1-121-357-00		1-121-417-00
220	1-121-419-00		1-121-420-00			1-121-421-00		1-121-422-00		1-121-261-00		1-121-423-00
330	1-121-751-00		1-121-805-00			1-121-521-00		1-121-654-00		1-121-655-00		1-121-656-00
470	1-121-424-00		1-121-425-00			1-121-426-00		1-121-733-00		1-121-261-00		1-121-810-00
1000			1-121-736-00			1-121-243-00		1-121-657-00		1-121-354-00		1-121-061-00
2200	1-121-658-00		1-121-659-00			1-121-660-00		1-123-067-00		1-121-954-00		
3300	1-121-661-00		1-123-073-00			1-123-071-00						

CAP. (μF)	100 VOLT.	160 VOLT.	250 VOLT.	350 VOLT.
	PART No.	PART No.	PART No.	PART No.
0.47				
1.0	1-123-249-00	1-123-252-00	1-123-003-00	1-121-168-00
2.2	1-123-250-00	1-123-026-00		1-123-028-00
3.3	1-121-995-00		1-123-004-00	1-123-006-00
4.7	1-123-255-00	1-121-246-00	1-121-759-00	1-123-007-00
10	1-121-126-00	1-121-994-00	1-123-254-00	1-123-008-00
22	1-121-996-00	1-123-255-00	1-123-005-00	1-123-022-00
33	1-121-997-00	1-121-757-00		
47	1-123-251-00	1-121-919-00		
100	1-123-084-00			

CERAMIC CAPACITORS

RATING							
CAP. (pF)	50 VOLT.	CAP. (pF)	50 VOLT.	CAP. (pF)	50 VOLT.	CAP. (pF)	50 VOLT.
	PART No.		PART No.		PART No.		PART No.
0.5	1-101-837-00	22	1-102-959-00	150	1-101-361-00	0.001	1-102-074-00
0.75	1-101-586-00	24	1-102-960-00	160	1-101-367-00	0.0012	1-102-118-00
1.0	1-102-934-00	27	1-102-961-00	180	1-102-976-00	0.0015	1-102-119-00
1.5	1-101-576-00	30	1-102-962-00	200	1-102-977-00	0.0018	1-102-120-00
2.0	1-102-935-00	33	1-102-963-00	220	1-102-978-00	0.0022	1-102-121-00
3	1-102-936-00	36	1-102-964-00	240	1-102-979-00	0.0027	1-102-122-00
4	1-102-937-00	39	1-102-965-00	270	1-102-980-00	0.0033	1-102-123-00
5	1-102-942-00	43	1-102-966-00	300	1-102-981-00	0.0039	1-102-124-00
6	1-102-943-00	47	1-101-880-00	330	1-102-820-00	0.0047	1-102-125-00
7	1-102-944-00	51	1-101-882-00	360	1-102-821-00	0.0056	1-102-126-00
8	1-102-945-00	56	1-101-884-00	390	1-102-822-00	0.0068	1-102-127-00
9	1-102-946-00	62	1-101-886-00	430	1-102-823-00	0.0082	1-102-128-00
10	1-102-947-00	68	1-101-888-00	470	1-102-824-00	0.01	1-102-129-00
11	1-102-948-00	75	1-101-890-00	510	1-101-054-00	0.012	1-101-005-00
12	1-102-949-00	82	1-102-971-00	560	1-102-115-00	0.0147	1-101-006-00
13	1-102-950-00	91	1-102-972-00	630	1-102-116-00		
15	1-102-951-00	100	1-102-973-00	820	1-102-117-00		
16	1-102-952-00	110	1-102-815-00				
18	1-102-953-00	120	1-102-816-00				
20	1-102-955-00	130	1-101-081-00				

0.001μF = 1,000pF

CERAMIC (SEMICONDUCTOR) CAPACITORS

RATING → Use the high voltage rated one.					
CAP. (μF)	25 VOLT.		CAP. (μF)	50 VOLT.	
	PART No.	PART No.		PART No.	PART No.
0.001		1-161-039-00	0.018	1-161-016-00	1-161-054-00
0.0012		1-161-040-00	0.022	1-161-017-00	1-161-055-00
0.0015		1-161-041-00	0.027	1-161-018-00	1-161-056-00
0.0018		1-161-042-00	0.033	1-161-019-00	1-161-057-00
0.0022		1-161-043-00	0.039	1-161-010-00	1-161-058-00
0.0027		1-161-044-00	0.047	1-161-021-00	1-161-059-00
0.0033		1-161-045-00	0.056		1-161-060-00
0.0039		1-161-046-00	0.068		1-161-061-00
0.0047		1-161-047-00	0.082	1-161-024-00	1-161-062-00
0.0056		1-161-048-00	0.1	1-161-025-00	1-161-063-00
0.0068		1-161-049-00			
0.0082	1-161-012-00	1-161-050-00			
0.01	1-161-013-00	1-161-051-00			
0.012		1-161-052-00			
0.015	1-161-015-00	1-161-053-00			

MYLAR CAPACITORS

CAP. (μF)	RATING																	
	50 VOLT.			100 VOLT.			200 VOLT.			50 VOLT.			100 VOLT.			200 VOLT.		
	PART No.	PART No.	PART No.	PART No.	PART No.	PART No.	PART No.	PART No.	PART No.	PART No.	PART No.	PART No.	PART No.	PART No.	PART No.	PART No.		
0.001	1-108-227-00	1-108-365-00	1-108-409-00	0.01	1-108-239-00	1-108-377-00	1-108-421-00	0.1	1-108-251-00	1-108-389-00	1-108-433-00							
0.0012	1-108-351-00	1-108-366-00	1-108-410-00	0.012	1-108-257-00	1-108-378-00	1-108-422-00	0.12	1-108-363-00	1-108-390-00	1-108-434-00							
0.0015	1-108-228-00	1-108-367-00	1-108-411-00	0.015	1-108-240-00	1-108-379-00	1-108-423-00	0.15	1-108-252-00	1-108-391-00	1-108-435-00							
0.0018	1-108-352-00	1-108-368-00	1-108-412-00	0.018	1-108-358-00	1-108-380-00	1-108-424-00	0.18	1-108-364-00	1-108-392-00	1-108-436-00							
0.0022	1-108-230-00	1-108-369-00	1-108-413-00	0.022	1-108-242-00	1-108-381-00	1-108-425-00	0.22	1-108-254-00	1-108-393-00	1-108-437-00							
0.0027	1-108-353-00	1-108-370-00	1-108-414-00	0.027	1-108-359-00	1-108-382-00	1-108-426-00	0.27	1-108-854-00	-	-							
0.0033	1-108-232-00	1-108-371-00	1-108-415-00	0.033	1-108-244-00	1-108-383-00	1-108-427-00	0.33	1-108-855-00	-	-							
0.0039	1-108-354-00	1-108-372-00	1-108-416-00	0.039	1-108-360-00	1-108-384-00	1-108-428-00	0.39	1-108-856-00	-	-							
0.0047	1-108-234-00	1-108-373-00	1-108-417-00	0.047	1-108-246-00	1-108-385-00	1-108-429-00	0.47	1-108-857-00	-	-							
0.0056	1-108-355-00	1-108-374-00	1-108-418-00	0.056	1-108-361-00	1-108-386-00	1-108-430-00	-	-	-	-							
0.0068	1-108-237-00	1-108-375-00	1-108-419-00	0.068	1-108-249-00	1-108-387-00	1-108-431-00	-	-	-	-							
0.0082	1-108-356-00	1-108-376-00	1-108-420-00	0.082	1-108-362-00	1-108-388-00	1-108-432-00	-	-	-	-							



TANTALUM CAPACITORS

CAP. (μF)	RATING						
	→ Use the high voltage rated one.						
	3.15 VOLT.	6.3 VOLT.	10 VOLT.	16 VOLT.	20 VOLT.	25 VOLT.	35 VOLT.
PART No.	PART No.	PART No.	PART No.	PART No.	PART No.	PART No.	PART No.
0.01							1-131-396-00
0.015							1-131-397-00
0.022							1-131-398-00
0.033							1-131-399-00
0.047							1-131-400-00
0.068							1-131-401-00
0.1							1-131-402-00
0.15							1-131-403-00
0.22							1-131-404-00
0.33							1-131-405-00
0.47					1-131-412-00		1-131-406-00
0.68				1-131-415-00		1-131-410-00	1-131-407-00
1.0			1-131-418-00		1-131-413-00		1-131-408-00
1.5		1-131-421-00		1-131-416-00		1-131-411-00	1-131-348-00
2.2	1-131-424-00		1-131-419-00		1-131-414-00	1-131-355-00	1-131-349-00
3.3		1-131-422-00		1-131-417-00	1-131-362-00	1-131-356-00	1-131-350-00
4.7	1-131-425-00		1-131-420-00	1-131-369-00	1-131-363-00	1-131-357-00	1-131-351-00
6.8		1-131-423-00	1-131-376-00	1-131-370-00	1-131-364-00	1-131-358-00	1-131-352-00
10	1-131-426-00	1-131-383-00	1-131-377-00	1-131-371-00	1-131-365-00	1-131-359-00	1-131-353-00
15	1-131-390-00	1-131-384-00	1-131-378-00	1-131-372-00	1-131-366-00	1-131-360-00	-
22	1-131-391-00	1-131-385-00	1-131-379-00	1-131-373-00	1-131-367-00		
33	1-131-392-00	1-131-386-00	1-131-380-00	1-131-374-00			
47	1-131-393-00	1-131-387-00	1-131-381-00				
68	1-131-394-00	1-131-388-00					
100	1-131-395-00						

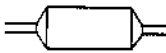

TANTALUM CAPACITORS

CAP. (μF)	RATING					
	3 VOLT.	6.3 VOLT.	10 VOLT.	16 VOLT.	20 VOLT.	35 VOLT.
	PART No.	PART No.	PART No.	PART No.	PART No.	PART No.
0.033						1-131-273-00
0.047						1-131-274-00
0.068						1-131-275-00
0.1						1-131-276-00
0.15						1-131-277-00
0.22					1-131-262-00	1-131-278-00
0.33					1-131-263-00	1-131-279-00
0.47			1-131-169-00		1-131-264-00	1-131-280-00
0.68					1-131-258-00	1-131-281-00
1.0			1-131-254-00		1-131-265-00	1-131-282-00
1.5		1-131-250-00			1-131-266-00	1-131-283-00
2.2				1-131-259-00	1-131-267-00	1-131-284-00
3.3			1-131-255-00		1-131-268-00	-
4.7		1-131-251-00	1-131-171-00		1-131-269-00	-
6.8				1-131-260-00	1-131-271-00	-
10			1-131-256-00		1-131-272-00	-
15				1-131-261-00		-
22			1-131-257-00			-
33	1-131-176-00	1-131-253-00	1-131-173-00			-
47	1-131-288-00	1-131-174-00				-
100	1-131-177-00					-

1/8 WATT CARBON RESISTOR

Ω	Part No.	Ω	Part No.	Ω	Part No.	Ω	Part No.	Ω	Part No.	Ω	Part No.	Ω	Part No.
2.0	—	13	1-246-821-00	91	1-246-831-00	620	1-246-841-00	4.3k	1-246-851-00	30k	1-246-861-00	200k	1-246-871-00
2.2	1-246-751-00	15	1-246-761-00	100	1-246-771-00	680	1-246-781-00	4.7k	1-246-791-00	33k	1-246-801-00	220k	1-246-811-00
2.4	—	16	1-246-822-00	110	1-246-832-00	750	1-246-842-00	5.1k	1-246-852-00	36k	1-246-862-00	240k	1-247-054-00
2.7	1-246-752-00	18	1-246-762-00	120	1-246-772-00	820	1-246-782-00	5.6k	1-246-792-00	39k	1-246-802-00	270k	1-247-046-00
3.0	—	20	1-246-823-00	130	1-246-833-33	910	1-246-843-00	6.2k	1-246-853-00	42k	1-246-863-00	300k	1-247-055-00
3.3	1-246-753-00	22	1-246-763-00	150	1-246-773-00	1.0k	1-246-783-00	6.8k	1-246-793-00	47k	1-246-803-00	330k	1-247-047-00
3.6	—	24	1-246-824-00	160	1-246-834-00	1.1k	1-246-844-00	7.5k	1-246-854-00	51k	1-246-864-00	360k	1-247-056-00
3.9	1-246-754-00	27	1-246-764-00	180	1-246-774-00	1.2k	1-246-784-00	8.2k	1-246-794-00	56k	1-246-804-00	390k	1-247-048-00
4.3	—	30	1-246-825-00	200	1-246-835-00	1.3k	1-246-845-00	9.1k	1-246-855-00	62k	1-246-865-00	430k	1-247-057-00
4.7	1-246-755-00	33	1-246-765-00	220	1-246-775-00	1.5k	1-246-785-00	10k	1-246-795-00	68k	1-246-805-00	470k	1-247-049-00
5.1	—	36	1-246-826-00	240	1-246-836-00	1.6k	1-246-846-00	11k	1-246-856-00	75k	1-246-866-00	510k	1-247-058-00
5.6	1-246-756-00	39	1-246-766-00	270	1-246-776-00	1.8k	1-246-786-00	12k	1-246-796-00	82k	1-246-806-00	560k	1-247-050-00
6.2	—	43	1-246-827-00	300	1-246-837-00	2.0k	1-246-847-00	13k	1-246-857-00	91k	1-246-867-00	620k	1-247-059-00
6.8	1-246-757-00	47	1-246-767-00	330	1-246-777-00	2.2k	1-246-787-00	15k	1-246-797-00	100k	1-246-807-00	680k	1-247-051-00
7.5	1-246-818-00	51	1-246-828-00	360	1-246-838-00	2.4k	1-246-848-00	16k	1-246-858-00	110k	1-246-868-00	750k	1-247-060-00
8.2	1-246-758-00	56	1-246-768-00	390	1-246-778-00	2.7k	1-246-788-00	18k	1-246-798-00	120k	1-246-808-00	820k	1-247-052-00
9.1	1-246-819-00	62	1-246-829-00	430	1-246-839-00	3.0k	1-246-849-00	20k	1-246-859-00	130k	1-246-869-00	910k	1-247-061-00
10	1-246-759-00	68	1-246-769-00	470	1-246-779-00	3.3k	1-246-789-00	22k	1-246-799-00	150k	1-246-809-00	1M	1-247-053-00
11	1-246-820-00	75	1-246-830-00	510	1-246-840-00	3.6k	1-246-850-00	24k	1-246-860-00	160k	1-246-870-00		
12	1-246-760-00	82	1-246-770-00	560	1-246-780-00	3.9k	1-246-790-00	27k	1-246-800-00	180k	1-246-810-00		

HARDWARE NOMENCLATURE

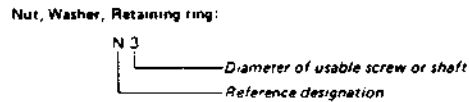
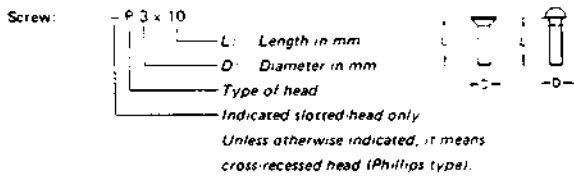

Reference Designation	Shape	Description	Remarks
SCREWS			
P		pan-head screw	binding-head (B) screw for replacement
PWH		pan-head screw with washer face	binding-head (B) screw and flat washer for replacement
PS PSP		pan-head screw with spring washer	binding-head (B) screw and spring washer for replacement
PSW PSPW		pan-head screw with spring and flat washers	binding-head (B) screw and spring and flat washers for replacement
R		round-head screw	binding-head (B) screw for replacement
K		flat-countersunk-head screw	
RK		oval-countersunk-head screw	
B		binding-head screw	
T		truss-head screw	binding-head (B) screw for replacement
F		flat-filister-head screw	
RF		filister-head screw	
BV		brazer-head screw	

Reference Designation	Shape	Description	Remarks
SELF-TAPPING SCREWS			
TA		self-tapping screw	ex. TA, P 3 x 10
PTP		pan-head self-tapping screw	binding-head self-tapping (TA, B) screw for replacement
PTPWH		pan-head self-tapping screw with washer face	binding-head self-tapping (TA, B) screw and flat washer for replacement
PTTWH		pan-head thread-rolling screw with washer face	binding-head (B) screw and flat washer for replacement
SET SCREWS			
SC		set screw	
SC		hexagon-socket set screw	ex. SC 2.6 x 4, hexagon socket
NUT			
N		nut	
WASHERS			
W		flat washer	
SW		spring washer	
LW		internal-tooth lock washer	ex. LW3, internal
LW		external-tooth lock washer	ex. LW3, external
RETAINING RINGS			
E		retaining ring	
G		grip-type retaining ring	

MDR-2L2

*US Model
Canadian Model
AEP Model
UK Model
E Model*



STEREO HEADPHONES

SPECIFICATIONS

Type:	Dynamic
Driver Units:	23 mm dia., dome
Impedance:	32 Ω at 1 kHz
Sensitivity:	95 dB/mW
Rated Power:	0.04 W
Power Handling Capacity:	0.1 W
Frequency Response:	45 – 20,000 Hz
Cord Length:	1.2 m long with mini plug
Weight:	Approx. 42 g (without cord) Approx. 58 g (with cord)

SONY
SERVICE MANUAL

DRIVER, CORD REMOVAL

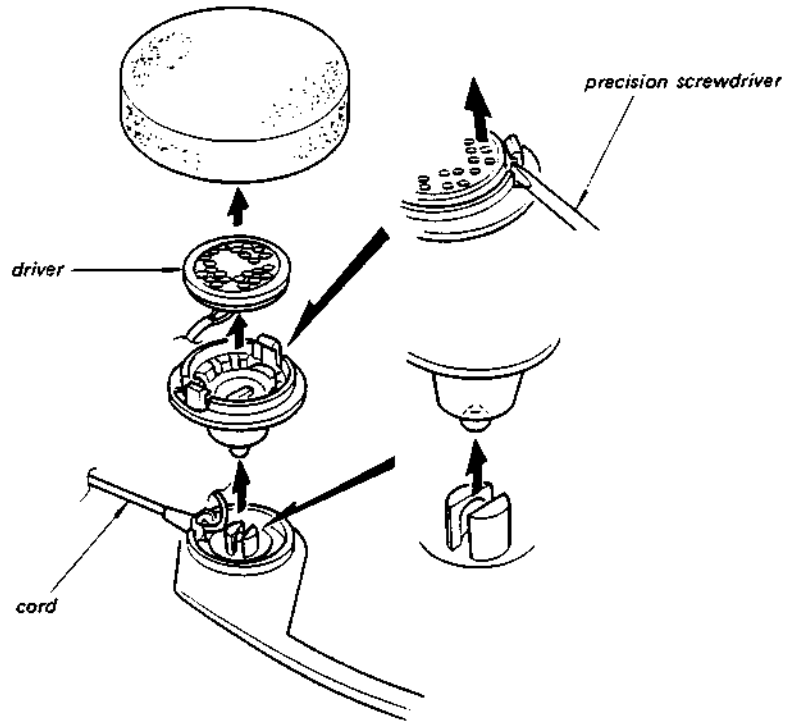

WIRING DIAGRAM

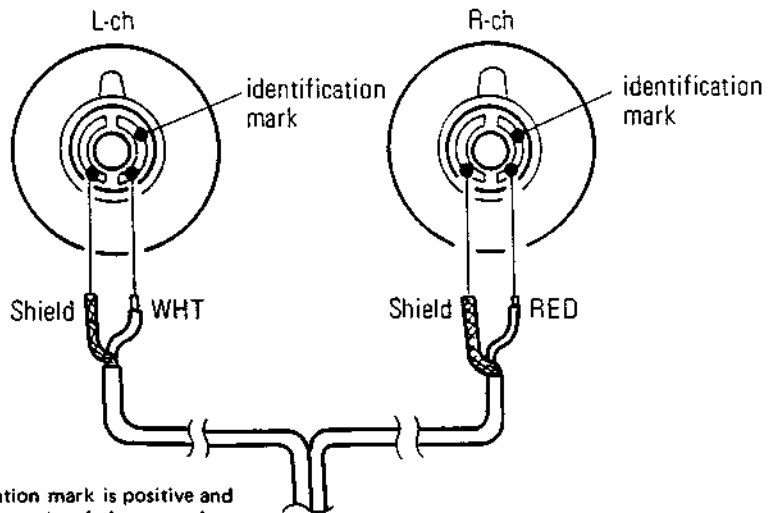

Note:
Pattern with identification mark is positive and above figure is one example of the case when the mark is on the right. Opposite case is possible.

EXPLODED VIEW

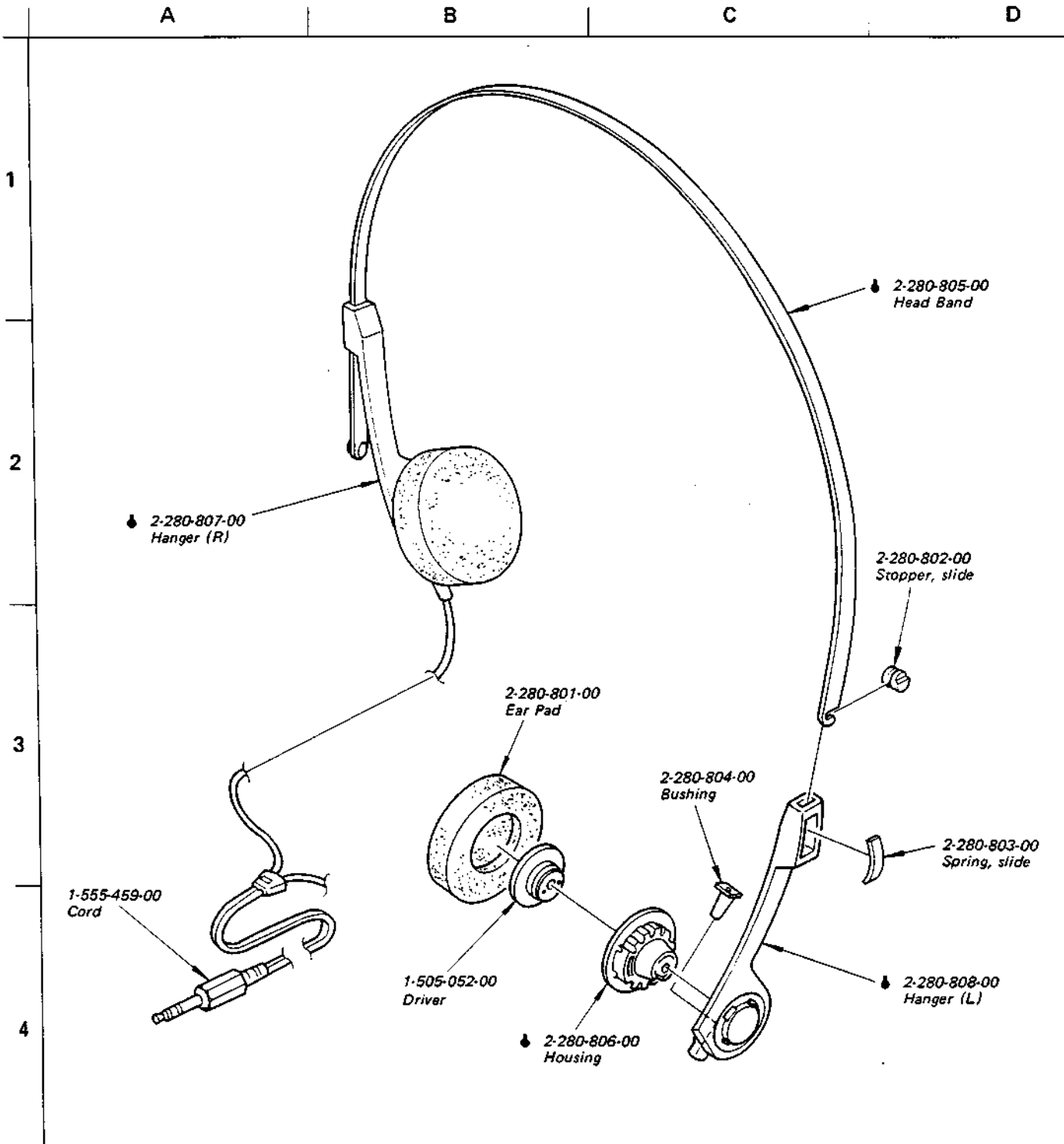

Note:

- Items marked "⚡" are not stocked since they are seldom required for routine service. Some delay should be anticipated when ordering these items.

PACKING MATERIAL

<u>Part No.</u>	<u>Description</u>
3-701-625-00	Bag, polyethylene

MDR-3L2

*US Model
Canadian Model
AEP Model
UK Model
E Model*



STEREO HEADPHONES

SPECIFICATIONS

Type:	Dynamic
Driver Units:	23 mm dia., dome
Impedance:	32 Ω at 1 KHz
Sensitivity:	96 dB/mW
Rated Power:	0.04 W
Power Handling Capacity:	0.1 W
Frequency Response:	20 – 20,000 Hz
Cord Length:	2 m long with mini plug
Weight:	Approx. 40 g (w/ thout cord)

SONY[®]
SERVICE MANUAL

MDR-3L2

1. DISASSEMBLY

Note: Follow the disassem

UNIT REMOVAL

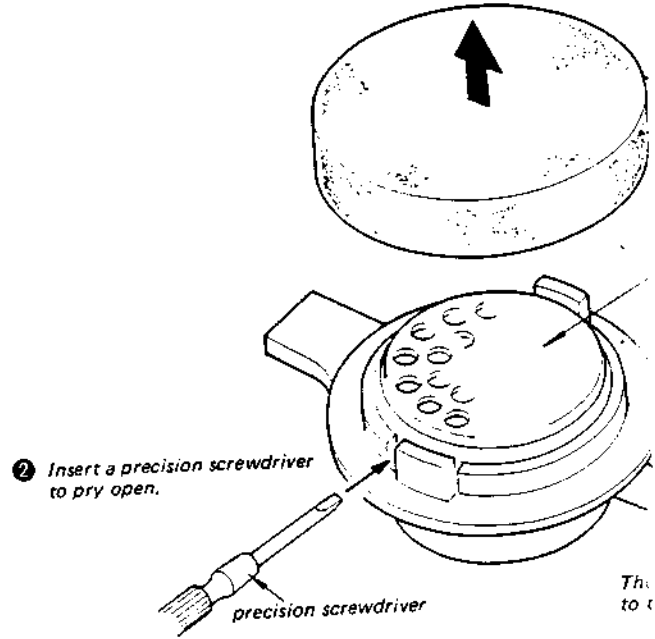

CORD REPLACEMENT

The replacement of the cord should be done after the ornamental cover removal. (The ornamental cover is glued to the hanger.)

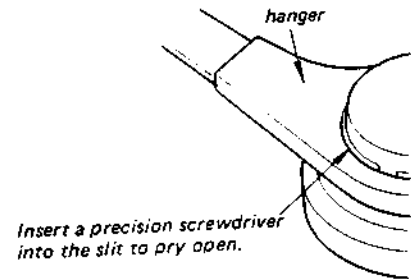

WIRING DIAGRAM

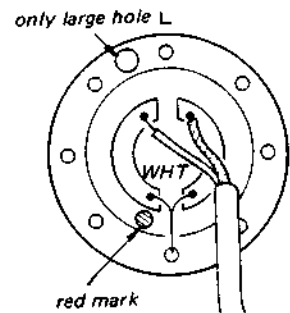

Red mark indicates ⊕ side. The illustration shown above is the set having red mark on the left. Some sets have red mark on the right.

2. EXPLODED VIEW

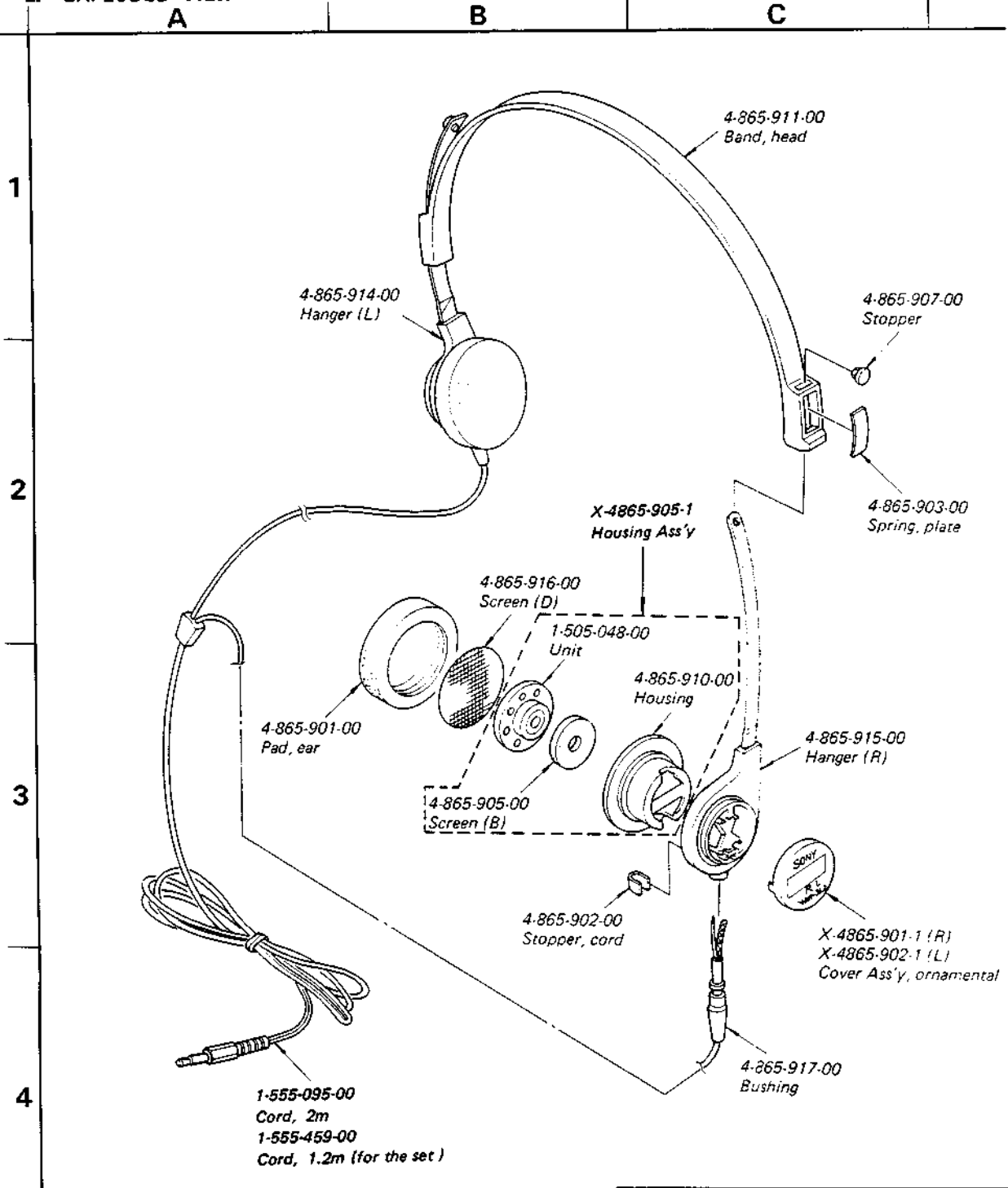

ACCESSORIES AND PACKING MATERIALS

<u>Part No.</u>	<u>Description</u>
1-506-400-00	Adaptor, plug
3-701-624-00	Bag
3-770-997-11	Manual, instruction
4-865-919-00	Carton
3-568-738-00	Bag, polyethylene (headphone)