

TCD-D7/D7K

SERVICE MANUAL

US Model
Canadian Model
AEP Model

TCD-D7

Tourist Model

TCD-D7K

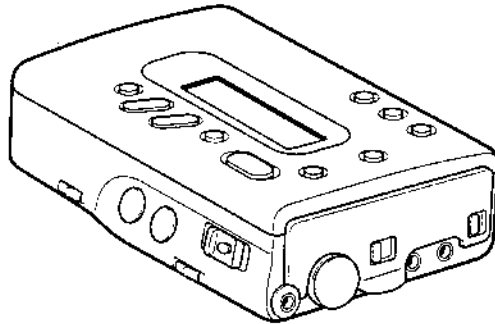

DAT
Digital Audio Tape

WALKMAN

SPECIFICATIONS

Tape	Digital audio tape
Recording time	Standard: 120 minutes Long-play mode: 240 minutes (with DT-120)
Sampling frequency	48 kHz, 44.1 kHz, 32 kHz
Frequency response	Standard: Fs 48 kHz 20 - 22,000 Hz (± 1.0 dB) Fs 44.1 kHz 20 - 20,000 Hz (± 1.0 dB) Fs 32 kHz 20 - 14,500 Hz (± 1.0 dB)
Signal to noise ratio	Long-play mode: Fs 32 kHz 20 - 14,500 Hz (± 1.0 dB) Standard: more than 90 dB Long-play mode: more than 90 dB (1 kHz IHF-A, 22 kHz LPF, LINE IN)
Dynamic range	Standard: more than 90 dB Long-play mode: more than 90 dB (1 kHz IHF-A, 22 kHz LPF, LINE IN)
Total harmonic distortion	Standard: less than 0.008% (1 kHz, 22 kHz LPF, LINE IN) Long-play mode: less than 0.09% (1 kHz, 22 kHz LPF, LINE IN)
Wow and flutter	Below measurable limit (less than $\pm 0.001\%$ W, PEAK)

Input	Jack type	Impedance	Rated input level	Minimum input level
MIC	stereo minijack	4.7 k Ω	-	0.4 mV
LINE IN	stereo minijack	47 k Ω	500 mV	80 mV

Output	Jack type	Impedance	Rated output	Maximum output level	Load impedance
PHONES/ LINE OUT	stereo minijack	27 Ω	LINE OUT 500 mV	PHONES 5 mW + 5 mW	LINE OUT more than 10 k Ω PHONES 32 Ω

Input/output

DIGITAL I/O • REMOTE jack (special jack)

Digital input/output, remote control operation and timer-activated operation is possible by connection with an adaptor kit to this jack.

Power requirements

- DC 6 V four LR6 (size AA) batteries
- DC IN 6V jack accepts:

the Sony AC power adaptor (supplied to the AEP, Tourist model only) for use on

	Operating voltage
US, Canadian model	120V AC, 60Hz
AEP model	220-230V AC, 50Hz
German model	120V AC, 60Hz or 220V AC, 50Hz
Tourist model	100-240V AC, 50/60Hz

Battery life

the car battery cord DCC-E160L (not supplied) for use with 12 V car battery.
(Approximately hours)

	Playback	Recording
Sony alkaline AM3 (N)	3.5	4 (3*)
Sony Ni-AA	2	2 (1.5*)

* while monitoring with the headphones

Power consumption

1.2 W

Dimension

Approx. 132.6 x 36.7 x 68.2 mm (5 1/4 x 1 1/2 x 3 1/2 in.) (w/h/d) not incl. projecting parts and controls

Mass

Approx. 500 g (1 lb., 10z.) incl. batteries

Model Name Using Similar Mechanism	TCD-D3
Tape Transport Mechanism Type	MT-D7-47

Accessories supplied

- Carrying case (1)
- AC power adaptor AC-E60L (1) (AEP model only)

For the Tourist model only

- Carrying case (1)
- LR6 (size AA) batteries (4)
- AC power adaptor AC-E60AM (1)
- Plug adaptor (1)
- Audio connecting cords (2)
(2 phono plugs \leftrightarrow stereo-mini plug, stereo for line inputs and outputs)
- Digital cable POC-DA12 (1)
(special plug \leftrightarrow 2 optical plugs)
- Remote commander RMT-D7 (1)
- Cleaning cassette CT-10CL (1)

For the operation of the AC power adaptor and the remote commander, refer to each operating instructions manual.

Design and specifications subject to change without notice.



DIGITAL AUDIO TAPE-CORDER
SONY

Features

Easy operation with excellent sound quality of DAT

Superb quality recording and playback with excellent frequency response, remarkably low noise and lack of distortion can be made. High speed fast-forwarding/rewinding and cuing/reviewing for easy tape access.

Long play (LP) mode recording

A maximum of four-hour continuous recording is possible using four LR6 (size AA) alkaline batteries which is ideal for recording a meeting or a conference etc.

Adjustable (automatic/manual) recording level

The recording level can be adjusted either manually or automatically to suit every recording situation.

Date function

The date and time are automatically registered at the time of the recording and can be displayed during playback, fast-forwarding/rewinding and cuing/reviewing.

LCD display

LCD display window for indicating the current operational mode and the battery power status etc.

Compact design

A compact mechanism and design for portability.

Recording compatibility

Recording can be made from various digital audio equipment such as a CD (compact disc)/MiniDisc player or a BS (broadcasting satellite)/CS (communication satellite) tuner etc.

TABLE OF CONTENTS

<u>Section</u>	<u>Title</u>	<u>Page</u>
1. GENERAL		
	Location and Function of Controls	3
	Power Sources	3
	Setting the Clock	4
	Inserting a Cassette	4
	Recording	4
	Playback	6
	Useful Function	7
	Serial Copy Management System	7
	Display Window	7
2. DISASSEMBLY		
2-1.	Lower Panel Assy	9
2-2.	Main Board	9
2-3.	Cassette Lid Assy	10
2-4.	System Control Board Unit	10
2-5.	Cabinet	11
2-6.	Bracket	11
2-7.	Drum Assy	12
3. DIAGRAMS		
3-1.	Pin Description	13
3-2.	Semiconductor Lead Layouts	18
3-3.	Printed Wiring Boards	19
3-4.	Schematic Diagram—Analog Section—	23
3-5.	Schematic Diagram—Main Section—	27
4. EXPLODED VIEWS		
4-1.	Cabinet Section	33
4-2.	Cassette Holder Section	34
4-3.	Mechanism Deck Section 1	35
4-4.	Mechanism Deck Section 2	36
4-5.	Mechanism Deck Section 3	37
5. ELECTRICAL PARTS LIST		38

SECTION 1 GENERAL

This section is extracted from instruction manual.

Location and Function of Controls

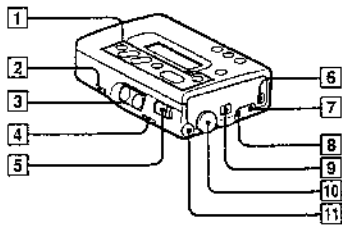

Refer to the pages in ● for details.

- 1 **Tape operation buttons:**
 - ◀◀/▶▶ (rewind/review • AMS) button ①
 - STOP button ②
 - ▶▶▶▶ (fast-forward/cue • AMS) button ③
 - REC (record)/ID WRITE (start ID write) button ④
 - ⏸ PAUSE button ⑤
- 2 SP/LP (standard play/long play mode select) button ④
- 3 VOLUME buttons ⑥
- 4 PHONES, AVLS/LINE OUT (headphones, automatic volume limiter system/line out select) switch ⑦
- 5 HOLD/PUSH OPEN switch ⑧

Slide this switch to the HOLD position to avoid any accidental operation while the unit is set in a particular operational mode. The use of this switch is recommended whenever you record or play back a tape. However, the display modes can still be changed by pressing the CLOCK/SET button, the COUNTER- button or the RESET/+ button even when the unit is in the hold mode.

- 6 MIC SENS (microphone sensitivity) switch ⑨
- 7 MIC (microphone) jack ⑩
- 8 LINE IN (line input) jack ⑪
- 9 REC MODE (recording mode) switch ⑫
- 10 REC LEVEL (recording level) knob ⑬
- 11 PHONES/LINE OUT (headphones/line output) jack ⑭

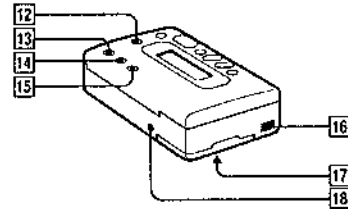

- 12 LIGHT button

Press to illuminate the display window when using the unit in the dark.
- 13 RESET/+ button ⑮
- 14 COUNTER- button ⑯
- 15 CLOCK/SET button ⑰
- 16 DIGITAL I/O • REMOTE (digital input/output • remote) jack ⑱
- 17 Battery compartment door
- 18 DC IN 6V (external power input) jack ⑲

* Supplied only to the Sony world model

5 6

Power Sources

Using with Batteries

Use four LR6 (size AA) alkaline batteries.

- 1 Open the battery compartment door.

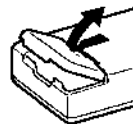

- 2 Pull out the battery case by holding the small knob.

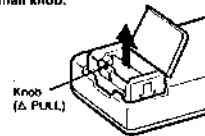

- 3 Insert the batteries into the battery case. Make sure that the - side of a battery is always inserted first.

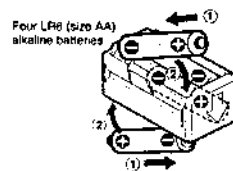

- 4 Insert the battery case into the unit.

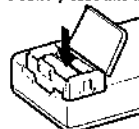

Remaining battery power status

The indicator constantly shows the remaining battery power status. This display comes on while the unit is being used with the batteries. They do not come on when the external power source is used.

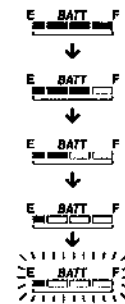

Replace the batteries at this point. If you continue to use the unit beyond this point, eventually the "BATTERY" message will come on the display window and the unit will cease to operate.

Notes

- * This unit is not equipped with a power switch. Consequently, as long as the batteries are inserted, the LCD display will always be turned on. However, the consumption of the electric current will be very small and negligible.
- * Do not leave the unit with its battery compartment door open for a long period of time, as doing so may cause the batteries to wear more quickly.

Display Window

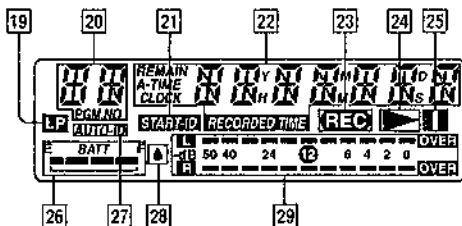

- 19 LP (long play) mode indicator ①
- 20 PGM.NO (program number) • day • AM/PM indicator ②
- 21 START-ID indicator ③
- 22 Tape counter/clock/message indicator
- 23 REC (recording) indicator
- 24 ▶ (playback) indicator
- 25 ⏸ (pause) indicator
- 26 BATT (remaining battery power status) indicator ④
- 27 AUTO-ID (automatic ID signal) indicator ⑤
- 28 Moisture condensation Indicator ⑥
- 29 Peak level indicators ⑦

Notes on batteries

- Insert four LR6 (size AA) alkaline batteries by matching the + and - on the batteries to the + and - in the battery case.
- Do not attempt to recharge the batteries.
- Do not use old batteries with new ones or different types of batteries together.
- When the unit is not to be used for an extended period of time, remove the batteries.
- If the electrolyte inside the battery should leak, wipe the contaminated area of the battery case with a cloth and replace the old batteries with new ones.
- Use only the alkaline batteries.
- Do not use any other type of dry batteries.

Note on separately sold rechargeable batteries

You can use the separately sold rechargeable batteries. However the expected recording/playback time will be shortened considerably.

Using with the AC power adaptor

Connect either the AC power adaptor AC-E60L** (not supplied) or AC-E60AM* (world wide) (not supplied) to the DC IN 6V jack of the unit.

Note

Use only the AC-E60L or AC-E60AM* AC power adaptor (not supplied). Do not use any other AC power adaptor.



*Except for the AEP model
**Except for the Tourist model

Using the power source of your car
Use the car battery cord DCC-E160L (not supplied).

Setting the Clock

The unit automatically registers the date of recording (year/month/date/day/hour/minute/second) at the time of recording. The date of recording can be then displayed on the display window while the unit is playing back, fast-forwarding/rewinding or cueing/reviewing a tape (Date function). It is essential to set the clock before any recordings are made. Otherwise, the date function will not work properly and the correct date and time of a recording will not be registered on the tape.

Proceed with the following steps while the unit is in the stop mode.

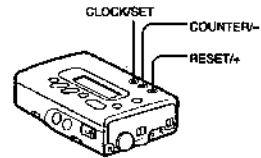

1 Press the CLOCK/SET button for more than four seconds.

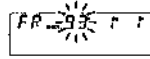

2 Press the COUNTER/RESET+ buttons to set the year digits, then press the CLOCK/SET button.

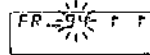

3 Press the COUNTER/RESET+ buttons to set the month digits, then press the CLOCK/SET button.

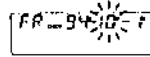

4 Press the COUNTER/RESET+ buttons to set the date digits, then press the CLOCK/SET button.

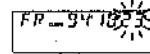

5 Press the COUNTER/RESET+ buttons to set the day, then press the CLOCK/SET button.

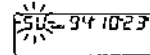

6 Repeat steps 2 to 4 to set the correct current time (hour/minute/second). The second digits change to "00" when the COUNTER/RESET+ or RESET+ button is pressed. Therefore, synchronize the clock by pressing either - or + button with the radio limo-signal etc.

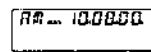

The flashing will stop and the clock will start activating.

To cancel the procedure Press one of the following buttons: ▶PLAY, ■STOP, ◀◀◀ or ▶▶▶ while proceeding with the steps. However, if you have proceeded to step 6, the year, month, day and date will be set.

To select either the 12-hour or the 24-hour clock display Press the RESET button for more than two seconds.

Notes
• If the HOLD/PUSH OPEN switch is set to the HOLD position, you cannot set the clock.
• If you leave the unit for more than an hour without any batteries installed, the clock display will return to any original factory-set setting (9 3 1 1 / FR 10 00 00). In this case, reset the clock after inserting the batteries.

Inserting a Cassette

1 Slide the HOLD/PUSH OPEN switch to the OPEN position.

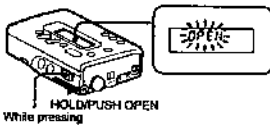

2 Open the cassette compartment door.



3 Insert a cassette with the window facing upward.

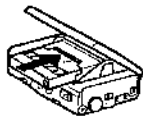

4 Close the cassette compartment door.

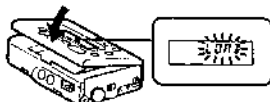

The cassette will be loaded automatically.

Notes

- When disconnecting the unit from the power source, make sure that the cassette compartment door is closed. Otherwise, you may not be able to close it afterward. If this happens, re-connect the power source.
- When inserting a cassette, make sure that the side with which the tape is visible inside is facing upward. If you insert the cassette upside down, you may not be able to take the cassette out.

To eject the cassette

While the unit is in the stop mode, slide the HOLD/PUSH OPEN switch to the OPEN position.

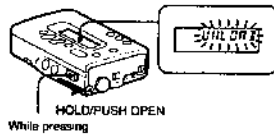

Record-protect shutter

Slide the record-protect shutter to the left to protect a recorded tape from being accidentally erased by recording on the tape for the second time.

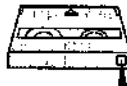

- If the shutter is open, you cannot record on the tape.
- If the shutter is closed, you can record on the tape.

9 10

Recording

Connection with Other Equipments

Recording with a microphone



The PLUG-IN POWER type microphones can be used as well.

Notes
• In this connection example, you need to adjust the recording level. See page 16 for details.
• You cannot use an auto-power supply type microphone such as the electret condenser stereo microphones ECM-S220 etc. with this unit.

Recording from a stereo set or a radio/cassette recorder etc. (analog connection)

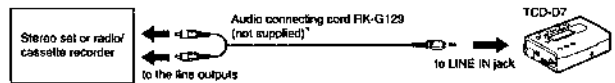

Notes
• In this connection example, you need to adjust the recording level. See page 16 for details.
• If a microphone is connected as well, the microphone connection will override the line connection.

Recording from equipment with digital outputs (digital connection)

There are two types of digital output connectors, the optical type and the coaxial type.

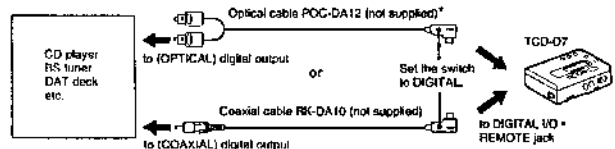

Notes
• In this connection example, you cannot adjust the recording level. The recording will be carried out at the same level as the source sound.
• Make sure that the switch on the connecting cable is set to the DIGITAL position before you start recording.

*Except for the Sony world model

The adaptor kit RM-D3K (not supplied)

This kit is equipped with the input/output connectors for both the optical cable and the coaxial cable. Therefore, you can use this kit as a relay between the TCD-D7 and another digital equipment. You can also remote control the TCD-D7 with the remote controller supplied to the RM-D3K. The timer operated recording or playback can be performed by adding an optional audio timer. See the operating instructions of the RM-D3K for details.

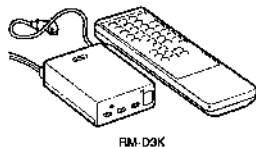

RM-D3K

Note
If you intend to use the RM-D3K, use the AC power adaptor (not supplied) for the power source of the TCD-D7.

*Except for the Touinst model

Before Recording

Use the following switches according to your needs.

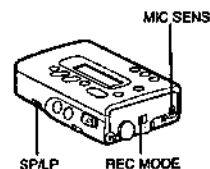

◆ SP/LP switch

SP: When the recording is to be made in the standard play mode. (The recording quality will be better with this mode.)

LP: When the recording is to be made in the long play mode.

LP mode

The recording time varies with the type of DAT cassette you use. See the chart below.

	SP mode	LP mode
DT-120	2 hours	4 hours
DT-90	1.5 hours	3 hours
DT-60	1 hour	2 hours

Notes

*If the sampling frequency (see page 20) of the digital input is either 44.1 kHz or 48 kHz while recording via the digital connection, the LP mode recording cannot be made even if you select the LP position with the SP/LP switch.

*You cannot play back a tape recorded in the LP mode on another DAT deck which is not equipped with the LP mode function.

*If you play back a tape, whose recording speed has been changed halfway from the SP mode to the LP mode, on a DAT deck which is not equipped with the LP mode function, you may experience some loud noise when the recording speed changes. In such a case, turn down the volume.

The tape counter display while the LP mode is used

The absolute time (see page 16) and the remaining tape time are based on the SP mode. Therefore, the actual time will be twice the amount of what is being shown on the display window.

◆ MIC SENS switch (for recording with a microphone)

H: Normally set the switch to this position.
L: When recording relatively loud sound (the built-in 20 dB attenuator will be activated).

◆ REC MODE switch

(When another equipment such as a microphone or a stereo set is connected to either the MIC or the LINE IN jack of the unit.)
MANUAL: When adjusting the recording level manually.

The recorded sound will become more faithful to the source sound. See page 16 for more details about adjusting the recording level.

MUSIC: When recording music. (The adjustment of the recording level will be made automatically.)

SPEECH: When recording a meeting or a conference etc. (The adjustment of the recording level will be made automatically.)

To confirm the source of Input
Press the REC button twice while the unit is in the stop mode, or if the unit is in the recording or pause mode, press the REC button once. One of the following indications will come on for approx. one second:

MIC or LINE or DIGITAL
These indications come on when the source of input has been changed as well.

To Record

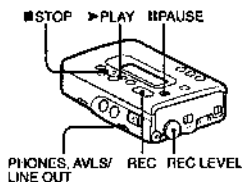

1 Insert a DAT cassette. (See page 11.)

2 Press the REC button and the II PAUSE button.

The unit enters the pause mode.
•When recording via a microphone or the analog connection, adjust the recording level with the REC LEVEL knob (Recording monitor mode) (see page 16).
•When recording from another equipment, engage the source equipment in the playback mode.

3 Press either the ►PLAY or the II PAUSE button.
The recording starts.

Notes

•The recording cannot be started by just pressing the REC button.
•You cannot adjust the output level of the LINE OUT jack of this unit.
•Care must be taken if disconnecting a plug from the PHONES/LINE OUT jack while recording, as doing so may cause some noise to be recorded.

To stop recording
Press the ■ STOP button.

To pause recording momentarily
Press the II PAUSE button.
To cancel the pause mode, press the II PAUSE button again or press the ►PLAY button.

Notes
•If the unit is left in the pause mode for more than five minutes, the unit will automatically enter the stop mode in order to protect its head and the tape.
•If the unit is left in the stop mode for more than 10 minutes, the unit will automatically disengage the tape from the built-in mechanism. The illumination of the display window will go out of the same time.

To monitor the sound while recording
Plug in the headphones (not supplied) or an active speaker system (not supplied) to the PHONES/LINE OUT jack of the unit.
If the headphones are to be used, set the PHONES, AVLS/LINE OUT switch to either the AVLS ON or AVLS OFF position.
If the active speakers are to be used, set the PHONES, AVLS/LINE OUT switch to the LINE OUT position. (You cannot control the volume with the unit.)

Notes
•If headphones are connected to the PHONES/LINE OUT jack of the unit, do not change the position of the PHONES, AVLS/LINE OUT switch to the LINE OUT position. (If you wish to do so, make sure that the headphones are unplugged first.) However, you can set the switch to either AVLS ON or AVLS OFF position.
•There may be cases where you experience some noise while monitoring the sound while recording via the digital connection.

Notes on Recording

Do not leave any unrecorded parts on a DAT tape

If there is a blank (unrecorded) part left on a DAT tape, the absolute time* will not be written thereafter. Also, when the tape is being fast-forwarded or rewound, it will stop at that point. In order not to leave any unrecorded parts on a tape while recording, observe the following:

- If you intend to continue to record on a tape which is partially recorded, make sure that you find the end of the previous recording first, then start the new recording from that point without leaving any unrecorded gap. (If you fast-forward the tape, it should automatically stop where the previous recording has ended.)
- If you wish to leave some blank parts, do not forward the tape with the ►PLAY button or the ►►► button. Keep the unit in the recording mode but without any input sound.

*The absolute time indicates the elapsed time from the beginning of the tape and the current position of the tape which is written digitally. The absolute time will be automatically written when you record a DAT tape for the very first time and cannot be erased once written.

Note
In some cases, the absolute time may not be written if you re-record on the tape on which the absolute time has not been written originally.

When you record to the end of a DAT tape
The tape automatically rewinds to the beginning and will stop there. (Auto-rewind function)

To Record Successfully

To adjust the recording level
Slide the REC MODE switch to the MANUAL position.
Rotate the REC LEVEL knob so that the peak level indicators on the display window flicker at around level ④. However, make sure that the level indicators do not go over the 0 dB mark when the pink sound level is recorded.

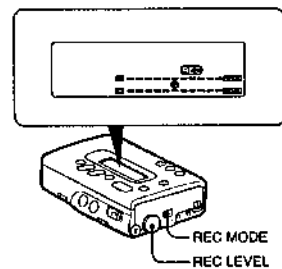

When the 0dB indicator(s) flicker(s)
The recording level is set too high. Lower the level in order to avoid the recorded sound from becoming distorted.

When recording relatively low sound
Lower the recording level and move the microphone as close as possible to the source. You should be able to make a clear recording with the least amount of noise.

Selecting a microphone best suited to the recording situation
The recording characteristics are affected by the type of microphone you use. For a high quality recording, use the ECM-959A (not supplied) or the ECM-737 (not supplied).

Playback

Connection with Other Equipments

Playback with stereo earphones



Playback with a connected stereo set or radio/cassette recorder etc. (analog connection)

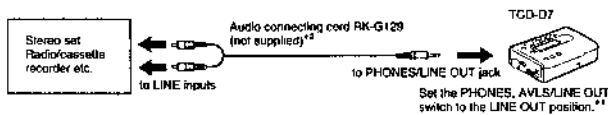

Playback with a connected equipment with digital input connectors (digital connection)

There are two types of digital input terminals: the optical type and the coaxial type.

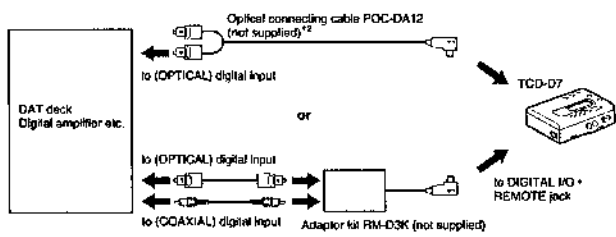

-1 When selecting other positions, make sure that the headphones, connecting cord etc. is unplugged from the PHONES/LINE OUT jack of the unit.
 -2 Except for the Sony world model

To Play back

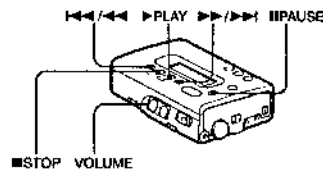

1 Insert a DAT cassette. (See page 11.)

2 Press the **▶ PLAY** button. Playback starts. The SP mode or the LP mode will be detected automatically, therefore, you do not have to adjust the SPLP switch.

3 Adjust the volume with the **VOLUME** buttons.

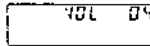

Note
 You cannot adjust the output level of the LINE OUT jack of this unit.

To stop playback
 Press the **■ STOP** button.

To pause playback momentarily
 Press the **⏸ PAUSE** button. To cancel the mode, press either the **⏸ PAUSE** button or the **▶ PLAY** button.

Notes
 -If the unit is left in the pause mode for more than five minutes, the unit will automatically enter the stop mode in order to protect its head and the tape.
 -If the unit is left in the stop mode for more than 10 minutes, the unit will automatically disengage the tape from the built-in mechanism. The illumination of the display window will go out at the same time.

To fast-forward the tape
 Press the **⏩▶▶▶▶▶** button when the unit is in the stop mode.

To rewind the tape
 Press the **⏪◀◀◀◀◀** button when the unit is in the stop mode.

When a tape is played back to the end
 The tape will be rewound to the beginning automatically and the unit enters the stop mode. (Auto-rewind function)

17 18

To fast-forward or rewind while monitoring the sound — cue/review

To cue	Keep ⏩▶▶▶▶▶ pressed during playback.	The tape is fast-forwarded/rewound while the button is held pressed. When you release the button, the unit goes back the normal playback mode.
To review	Keep ⏪◀◀◀◀◀ pressed during playback.	

If you press the **▶ PLAY** button and the **⏩▶▶▶▶▶** button or the **⏪◀◀◀◀◀** button during playback, the unit enters the high speed cue/review.

Locating the beginning of a program (track) — AMS* function

Press either the **⏩▶▶▶▶▶** or **⏪◀◀◀◀◀** button quickly once during playback. If the unit is in the fast-forward/rewind mode, press either the **⏩▶▶▶▶▶** or **⏪◀◀◀◀◀** button once. Or if the unit is in the stop mode, press either the **⏩▶▶▶▶▶** or **⏪◀◀◀◀◀** button twice.

To locate the beginning of the succeeding program (track)	Press ⏩▶▶▶▶▶ the same number of times as the programs (tracks) to be skipped.	E.g.: to locate the beginning of the fifth program (track)
To locate the beginning of the previous program (track)	Press ⏪◀◀◀◀◀ the same number of times as the programs (tracks) (including the currently played one) to be skipped.	E.g.: to locate the beginning of the fourth program (track) including the currently played one

* Automatic Music Sensor

Note
 The AMS function may not work properly if the start IDs are not registered on the tape or if the tape is recorded on another DAT deck. (See page 21.)

The AMS indication during fast-forward or rewind
 The peak level indicators (LR) show the tape transport direction and the remaining amount of tape to be wound.
 L indicator: tape transport direction
 R indicator: remaining amount of tape to be wound

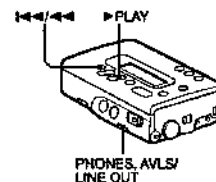

To listen to a tape with headphones with a more comfortable sound pressure level — AVLS* function
 When playing back a tape, set the switch to either the AVLS ON or the AVLS OFF position.
AVLS ON: Controls the sound pressure without degrading the sound quality when the volume is turned up. (Only when the headphones are used)
AVLS OFF: Normal sound reproduction

* The AVLS (Automatic Volume Limiter System) function automatically limits the sound pressure so that it will not exceed a certain level without degrading the sound quality, even if you attempt to turn the volume up higher. It also helps to reduce the sound leakage from your headphones.

Note
 The reproduced sound may be distorted or unstable due to the type of music (with enhanced bass) being played back. If this happens, turn the volume down.

To listen to a tape from the beginning after it has been rewound — Auto-play function
 While pressing down the **⏪◀◀◀◀◀** button, press the **▶ PLAY** button. When the tape is rewound to the beginning, the playback starts automatically.

To get the sampling frequency displayed during recording/playback
 Press and hold the **▶ PLAY** button during recording/playback. The sampling frequency will be displayed while the button is held pressed.

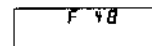

There are three types of sampling frequencies.

48 kHz	DAT SP (standard play) recording mode
44.1 kHz	CD and MD
32 kHz	DAT LP (long play) recording mode

19 20

Useful Function

Start ID

This signal indicates the beginning of a recorded program (track). By reading those start ID signals, the unit can cue the beginnings of the recorded programs (tracks) automatically.

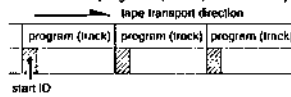

To write the start IDs

◆ To write the start IDs automatically while recording

The way in which these IDs are written depends on whether the **AUTO-ID** indicator is appearing on the display window or not.

The **AUTO-ID** indicator can be switched on and off by pressing the **REC** button while pressing down the **STOP** button.

When the **AUTO-ID** indicator is off

The way in which the start IDs are written depends on the way the recording has been done. See the chart below.

Recording via MIC Input Recording via LINE input	Only when the recording has started (including when the pause mode is released)
Recording from a CD player via digital input Recording from a DAT player via digital input	All the beginnings of programs (tracks)* All the start ID signals written on the original DAT tape will be registered.

* There may be cases where the start IDs may not be written by some CD players.

When the **AUTO-ID** indicator is on

The start IDs will be written if there is a section with a very low recording level or no sound at all lasting for more than three seconds is present on a program (track).

Note

There may be cases where the start IDs are not written properly if there is some noise present in the sound source.

◆ To write the start IDs manually while recording

While recording, press the **REC** button at the point where you wish to write the start ID.

Note

While writing the start IDs, the **WRITING** indication comes on and the **REHEARSAL** indicator flashes for about nine seconds (18 seconds if the unit is in the LP mode). While the unit is set in this mode, no operational buttons other than the **STOP** button will function.

PGM (program) numbers

These signals are used to identify the program (track) numbers. Examples in which the PGM numbers are registered are as follows:

To record a tape from the beginning

The PGM numbers will be registered simultaneously from PGM number 1 onward while the start IDs are being registered.

To record on a partially recorded tape

Locate the desired position on the tape by fast-forwarding or rewinding the tape using either the **FF** or **REW** button and have the PGM number displayed. Then start the new recording. While the new start IDs are being registered, the PGM numbers will be registered in sequence.

When the optional adaptor kit **RM-D3K** or the wired remote controller **RMT-D7*** is used with this unit, you will be able to do the following:

To write the start IDs during playback

You can write the start IDs in the desired positions without erasing the contents of the recording.

When the desired position on the tape is located,

the section of the tape lasting three seconds from that position will be played back repeatedly. (**Rehearsal** function)

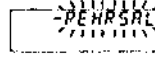

If the located position is not where you desired the start ID to be written, you can move that position in either direction by 0.3 second increments by the following method:

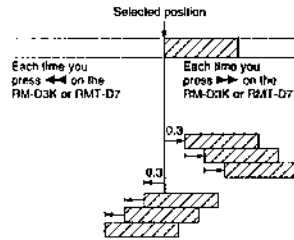

* The rehearsal function can only be repeated up to 16 times at the same position. After that, the unit shuts off automatically.
* You can move the position of a start ID forward or backward to the maximum of approx. 10 seconds

Notes

* You cannot move the start IDs which have already been written manually, or if they have been written automatically during recording. If you wish to move start IDs, erase the existing IDs first. Then select the desired sections before rewrite the IDs.
* You cannot write the start IDs while the rehearsal function is in operation or if the **REHEARSAL** indicator and **WRITING** indication are flashing rapidly.

To erase the start IDs

You can erase the start IDs without erasing the contents of the recording on the tape. (Only when the unit is in the stop or playback mode.)

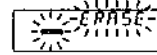

Note

If a start ID is erased, the PGM number which has been written at the same position will be erased as well.

To re-number the PGM numbers (Re-number function)

You may need to renumber the PGM numbers in the following cases:

- When the start IDs are written during playback.
- When the recording has been resumed from the middle of the tape so that the same PGM numbers co-exist on one tape.
- When the start IDs have been erased together with the PGM numbers so that some PGM numbers are missing.

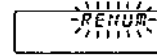

When the re-numbering is over, the tape will rewind to the beginning automatically and stop there.

Note

If a tape is used which has been recorded on another DAT deck and has a start ID written at the beginning of that tape, writing or re-numbering the PGM numbers on that tape may not be done properly.

* Except for the Sony world model

Serial Copy Management System

The Serial Copy Management System which is incorporated in the domestic DAT equipment prevents repeated digital dubbing from one equipment to another. However, this system lets you record at least one generation of digital prerecorded software via digital connections.

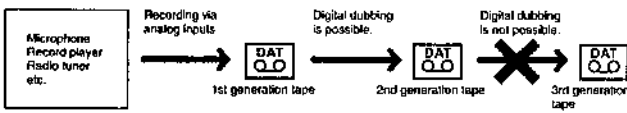
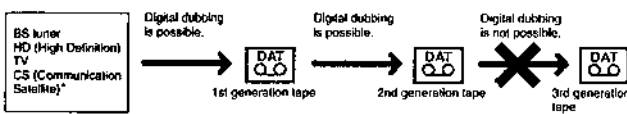

Notes

* There may be cases where the Serial Copy Management System rules are not applicable when an equipment which is not protected with the Serial Copy Management System is used in recording.
* Even if digital dubbing is impossible, you can still dub tape via analog connections.
* When digital dubbing is not possible, the message "COPY PROHIBIT" will come on the display window.

* These source examples may not apply to some countries.

Display Window

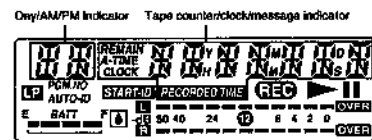

◆ The tape counter indications

Each time you press the **COUNTER** button, the display changes cyclically as follows:

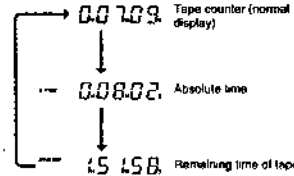

To reset the tape counter (normal display) to "00:00.9"
Press the **RESET** button.

Remaining time of the tape

The remaining time left on the tape will normally come on after about 16 seconds of commencing playback in the SP mode. However, there may be some aberration in the amount of time displayed which depends upon the tape you use.

Note

The tape counter should not be used as a clock. What is being displayed on the tape counter is not completely accurate in terms of displaying the actual time. Therefore, do not use the tape counter as a clock.

◆ Clock display

Each time you press the **CLOCK** button, the display changes cyclically as follows:

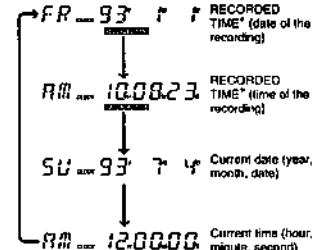

* The **RECORDED TIME** will not be displayed while the unit is in the recording, recording monitor, or pause mode.

◆ **Message Displays**

The following messages will be displayed while operating this unit.

ERROR	Comes on when the unit is malfunctioning due to a fault. → Disconnect the power source and re-connect it. If this does not improve the situation, disconnect the power source and take the unit to the nearest Sony dealer.
HOLD	Flashes when the HOLD/PUSH OPEN switch is set to the HOLD position.
NO TAPE	Flashes when there is no tape inside the unit.
TAPE- PROTECT	TAPE and PROTECT indicators come on alternately when a recording is attempted on a tape whose record-protect shutter is open.
NO INPUT	Flashes when the digital input signal is not received.
COPY- PROHIBIT	COPY and PROHIBIT indications come on alternately when the SCMS signal is received.
OPEN	Flashes when the cassette door is open.
LOAD	Flashes while loading a tape.
UNLOAD	Flashes while un-loading a tape.
TOP	Flashes when the beginning of a tape*1 is reached.
END	Comes on when the end of a tape is reached.
LINE OUT	Flashes when the PHONES, AV/LINE OUT switch is set to LINE OUT or when the VOLUME button is pressed in this mode.
BATTERY	Flashes when the batteries are weak.
EE END	Comes on when the end ID*2 is detected.
BLANK	Flashes when the unrecorded part of a tape is detected during playback or fast-forwarding.
WRITE	Comes on while the start IDs are being written.
MIC in	Comes on when the REC button is pressed twice while a microphone is connected. Or if the recording source is changed to that of microphone from another source.
LINE in	Comes on when the REC button is pressed twice while another equipment is connected via the analog connection. Or if the recording source is changed from another source to the equipment with analog connection.
DIGITAL	Comes on when the REC button is pressed twice while another equipment is connected via the digital connection. Or if the recording source is changed from another source to the equipment with digital connection.

*1 It flashes when a new (virgin) tape is used for the first time.

*2 The end ID is a signal to indicate the position of a tape where the recording has ended. You cannot register the end IDs with this unit, however the unit can play back the tapes which are registered with the end IDs and detect them. When the unit detects an end ID, it stops play back there and you can only forward the tape by recording from that point on the tape.

SECTION 2 DISASSEMBLY

Note : Follow the disassembly procedure in the numerical order given.

2-1. LOWER PANEL ASSY

Note) Set the knobs and slide switch to slide in the direction of arrow.

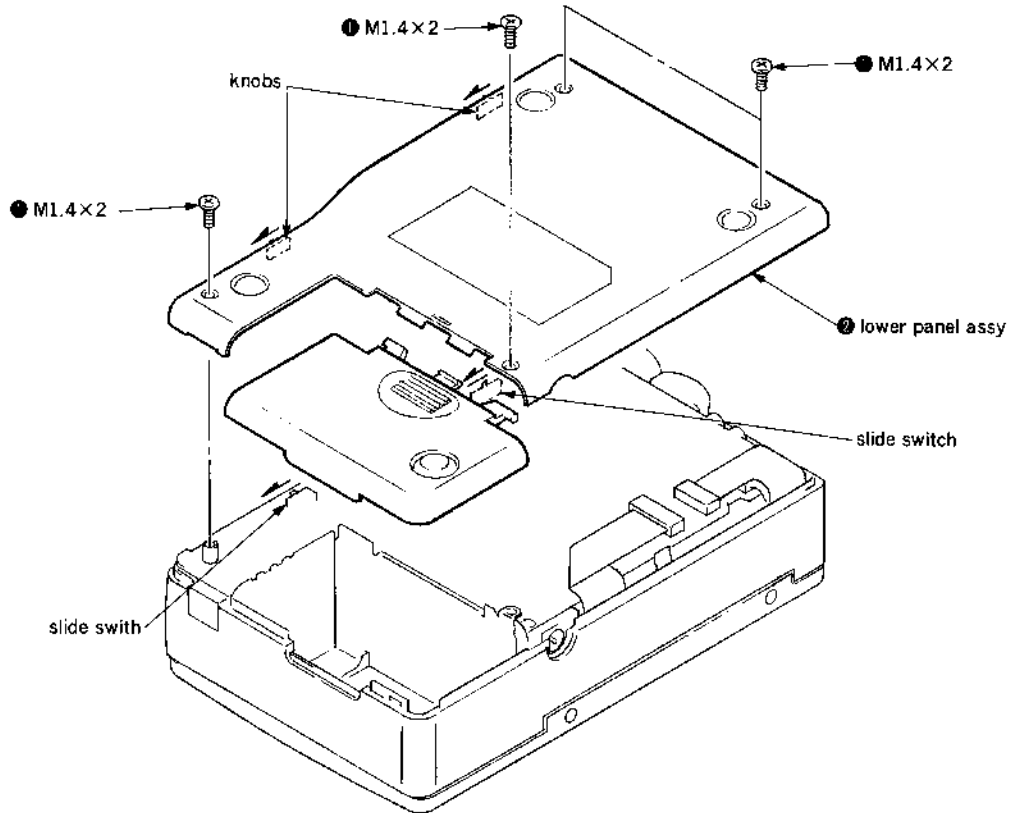

2-2. MAIN BOARD

Note) Set the knobs and slide switch.

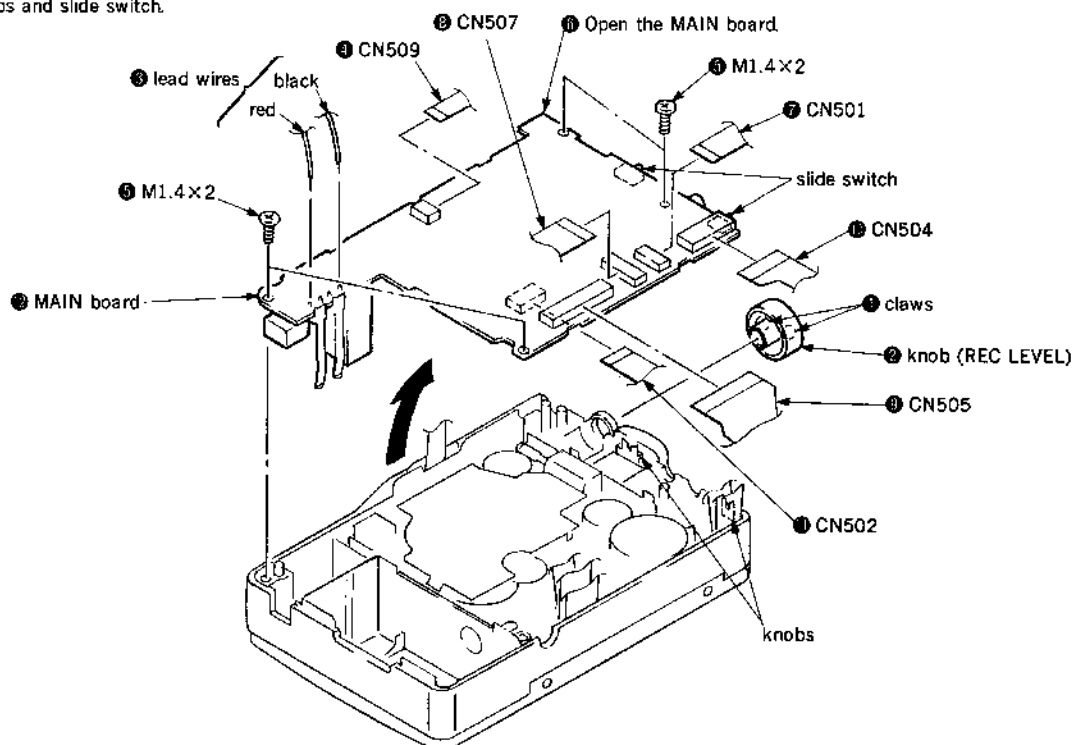

2-3. CASSETTE LID ASSY

➊ Push the lever in the direction of arrow and open the cassette lid.

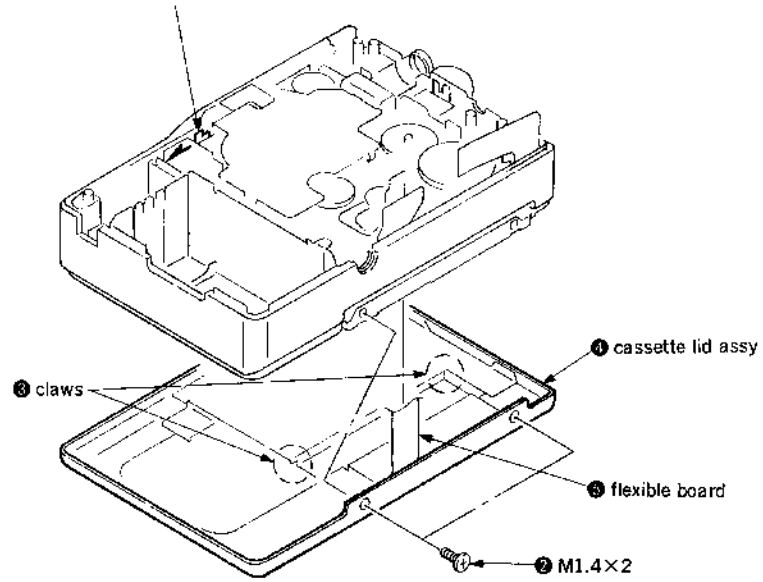

2-4. SYSTEM CONTROL BOARD UNIT

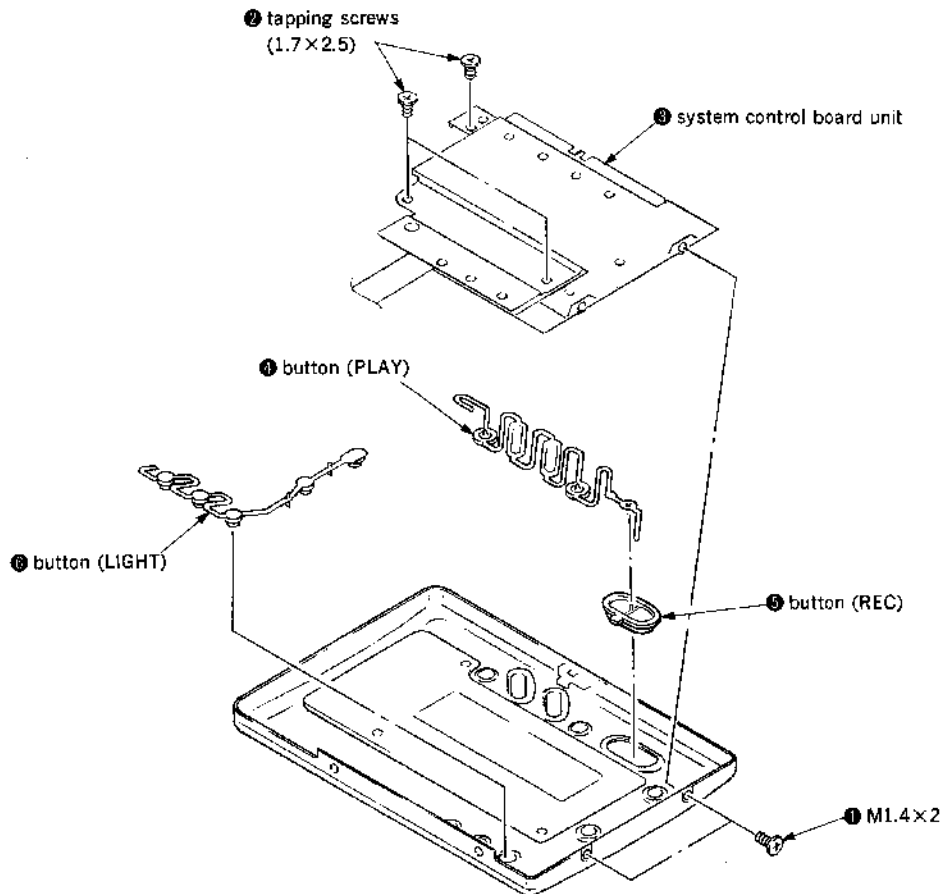

2-5. CABINET

Note) Set the knobs and slide switch.

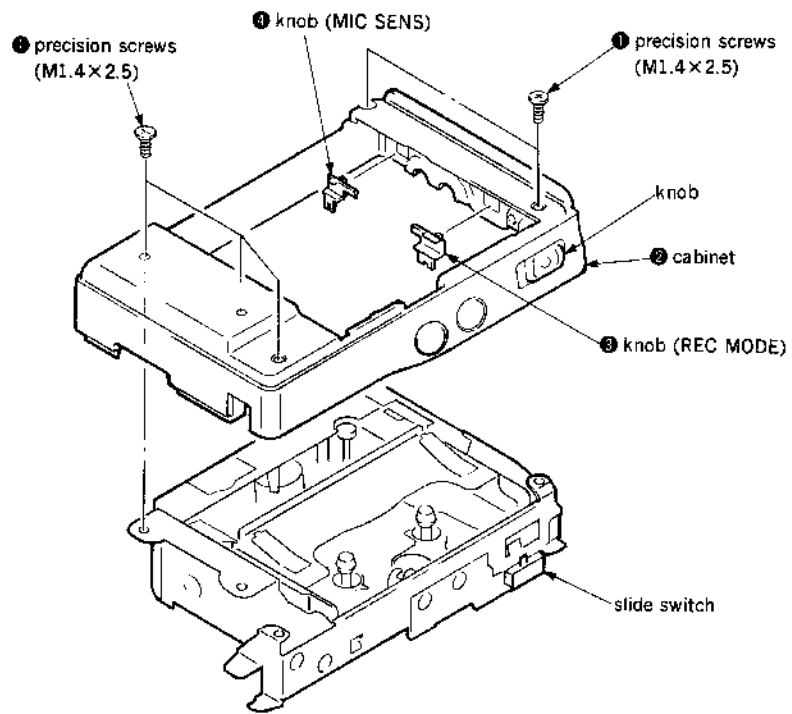

2-6. BRACKET

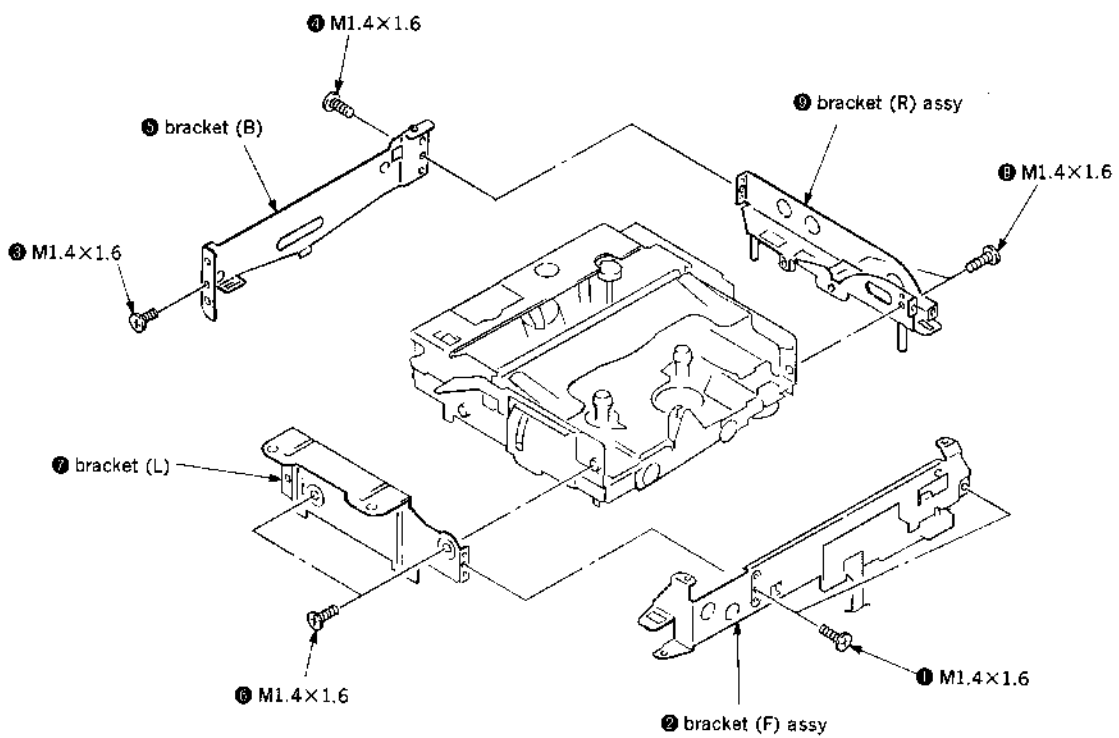

2-7. DRUM ASSY

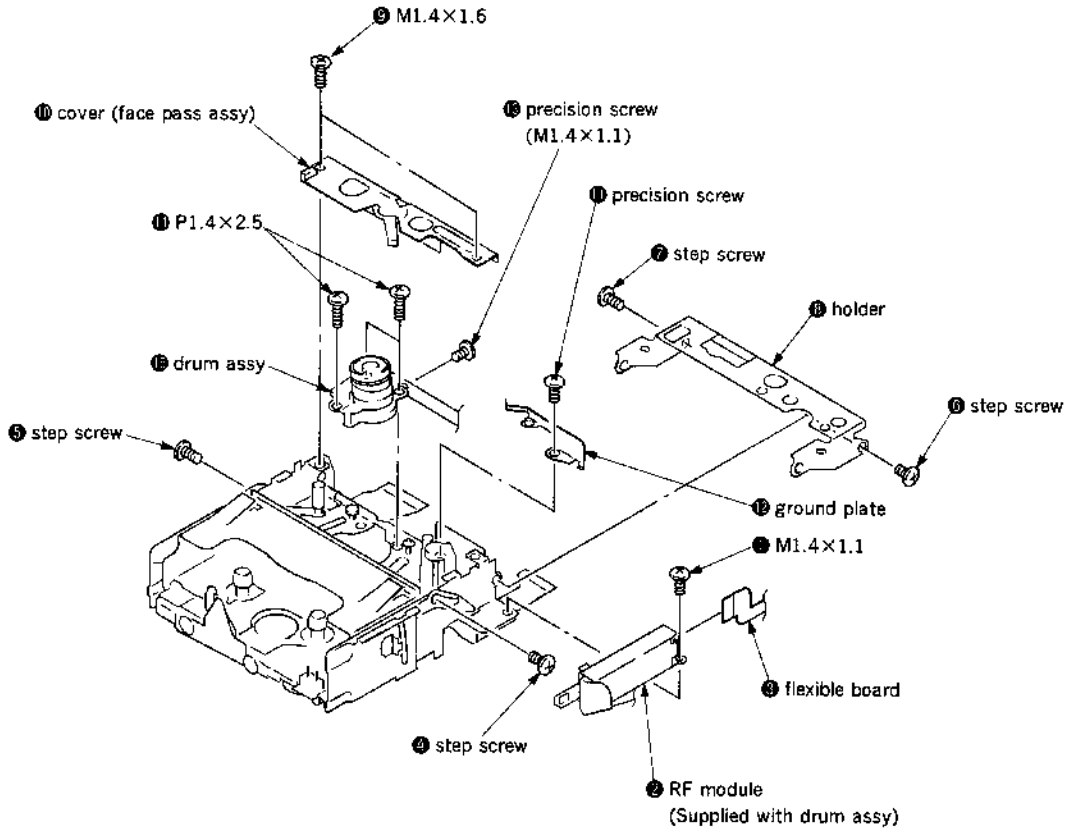

SECTION 3 DIAGRAMS

3-1. PIN DESCRIPTION ● IC506 CXP80524-078R

Pin No.	Pin Name	I/O	Pin Function
1	DMCRQ	O	Serial communication request signal to LCD micro-computer of system control board unit. ("L": Communication mode)
2	XSTBY	O	MB3796, CXA8022N and MCD002AM standby signal. ("L": Standby mode)
3	DRMBR	O	Drum motor brake signal ("H": Brake)
4	CAPDIR	O	Capstan motor rotation direction control signal ("H": FWD)
5	DACONT	O	Power ON/OFF signal of D/A converter section. ("L": Power ON)
6	XRSTDSP	O	CXD2605 reset signal ("L": Reset)
7	SYSPA W	O	System power ON/OFF signal ("H": Power ON)
8	LP/SPI	O	LP switch detection output
9		O	Not used
10		—	Not used
11	REI	I	Rotary encoder input 1
12	REM	I	Rotary encoder input 2
13		—	Not used
14	REO	I	Rotary encoder input 3
15	RELD	I	Load detection signal ("L": Load completion)
16	REULD	I	Unload detection signal ("L": Unload completion)
17	XRECINH	I	REC proof switch input ("L": REC prohibition)
18	XCASLK	I	Cassette compartment lock switch input ("L": Cassette compartment lock)
19	CASIN	I	Cassette insert detection ("H": Cassette insert)
20		—	Not used
21	XAVLS	I	AVLS switch input ("L": AVLS)
22	HP/LINE	I	HEADPHONE/LINE OUT switch input ("L": LINE OUT)
23	MIC/LINE	I	MIC/LINE IN switch input ("H": LINE IN)
24	MUTM	I	Mute output detection of CXD2605. ("H": Mute)
25	DIG/ANA	I	DIGITAL/ANALOG switch input ("L": DIGITAL)
26	VOL-	I	VOLUME DOWN switch input ("L": VOLUME DOWN)
27	VOL+	I	VOLUME UP switch input ("L": VOLUME UP)
28		—	Not used
29	AC/DC	I	AC/DC power detection ("L": AC power)
30	CTRMA	O	Control motor control signal
31	CTRMB	O	Control motor control signal
32	ENLDON	O	Tape top/end LED ON/OFF signal ("H": LED ON)
33		—	Not used
34	PLGON	O	Plunger ON/OFF signal ("H": Plunger ON)
35		—	Not used
36	MP	I	Fix to GND.
37	XRST	I	Reset input
38		—	Not used
39	VSS	—	GND
40	XTAL	O	Crystal oscillator (9.408MHz) output
41	EXTAL	I	Crystal oscillator (9.408MHz) input
42	LP/SP2	I	LP switch input ("L": LP)
43		—	Not used
44	SI	I	Serial data input from system control board unit.
45	SO	O	Serial data output to system control board unit and digital filter.
46		—	Not used
47	XSCK	O	Serial clock output to system control board unit and digital filter.
48	SBSY	I	Communication request signal from CXD2605. (Down edge to start communication)
49	SBSI	I	Serial data input from CXD2605.
50		—	Not used

Pin No.	Pin Name	I/O	Pin Function
51	SBSO	O	Serial data output to CXD2605.
52	EXCK	O	Serial clock output to CXD2605.
53	AVSS	—	Analog port GND
54	AVREF	—	Analog port reference GND
55	AVDD	—	+5V
56	SWPADJ	I	Switching pulse delay adjustment voltage input
57	RFENV	I	RF envelope detection input
58	REMOTE	I	Headphone remote control signal input
59	DEW	I	Dew sensor input ("L" : Dew)
60		—	Not used
61	TEND	I	Tape top sensor input ("L" : Tape top)
62	SEND	I	Tape end sensor input ("L" : Tape end)
63	BATTERY	I	Battery voltage level detection
64		—	Not used
65	ATFPLT	I	ATF pilot detection signal
66	TRLFG	I	Reel FG input of take up side (24 per 1 rotation)
67		—	Not used
68	SRLFG	I	Reel FG input of supply side (24 per 1 rotation)
69	CAPFG	I	Capstan FG input (360 per 1 rotation)
70	DRMFG	I	Drum FG input (24 per 1 rotation)
71	DRMPG	I	Drum PG input
72	DREF	I	Drum reference signal (LP mode : 16.7Hz, SP mode : 33.3Hz)
73	MCLK	I	Channel clock (9.408MHz)
74	RFDT	I	RF signal input
75	AVLS	O	AVLS ON signal
76		—	Not used
77	DRMPWM	O	Drum motor control PWM output (Carrier frequency : 36.75kHz)
78	CAPPWM	O	Capstan motor control PWM output (Carrier frequency : 36.75kHz)
79	ATFPWM	O	ATF gain control amplifier control PWM output (Carrier frequency : 36.75kHz)
80	DARST	O	Reset signal to D/A converter
81		—	Not used
82	MLE	O	Serial data take up signal to digital filter. (Up edge to take up)
83	SYMN	I	C1 syndrome pulse input
84	STBY	I	Sleep input ("H" : Sleep)
85		—	Not used
86, 87	VDD	—	+5V
88		—	Not used
89	VSS	—	GND
90		—	Not used
91	ASTY	O	ATF sync output
92		—	Not used
93	DMUTE	O	Digital mute signal ("H" : Mute)
94	HPVC	O	Headphone amplifier voltage control signal
95		—	Not used
96	MODE	O	Mode setting of RF amplifier ("H" : REC current ON)
97	LMUTE	O	LINE OUT mute signal ("H" : Mute)
98	ADCON	O	A/D converter ON/OFF signal
99		—	Not used
100	SWP	O	Switching pulse output ("L" : Ach head)

• IC Block Diagrams
IC302 TK15021MTL

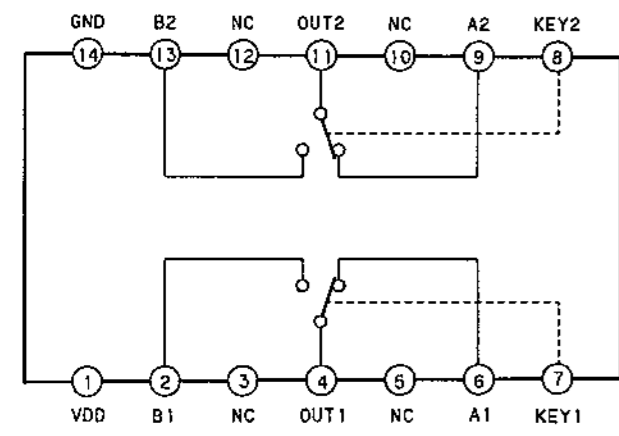

IC304 AK5344

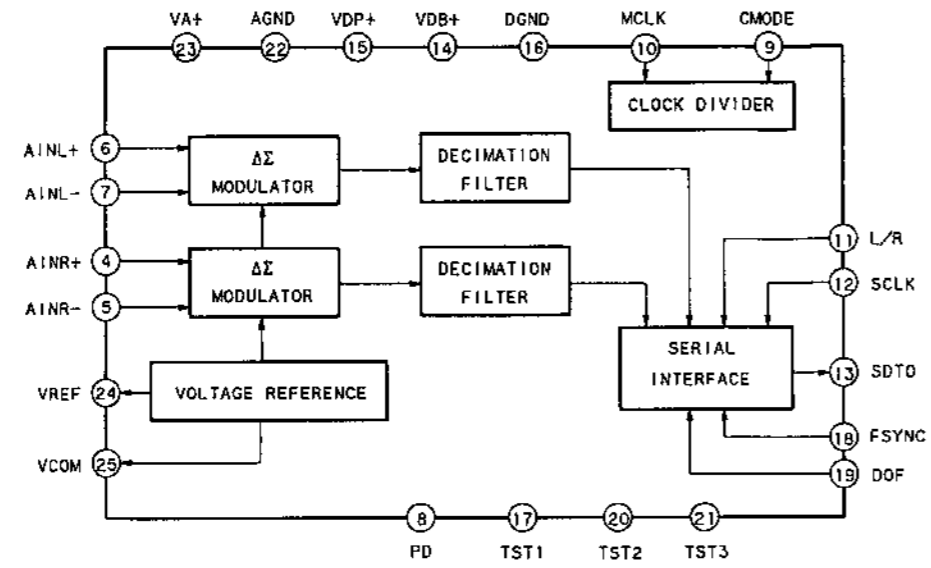

IC501 MB3796

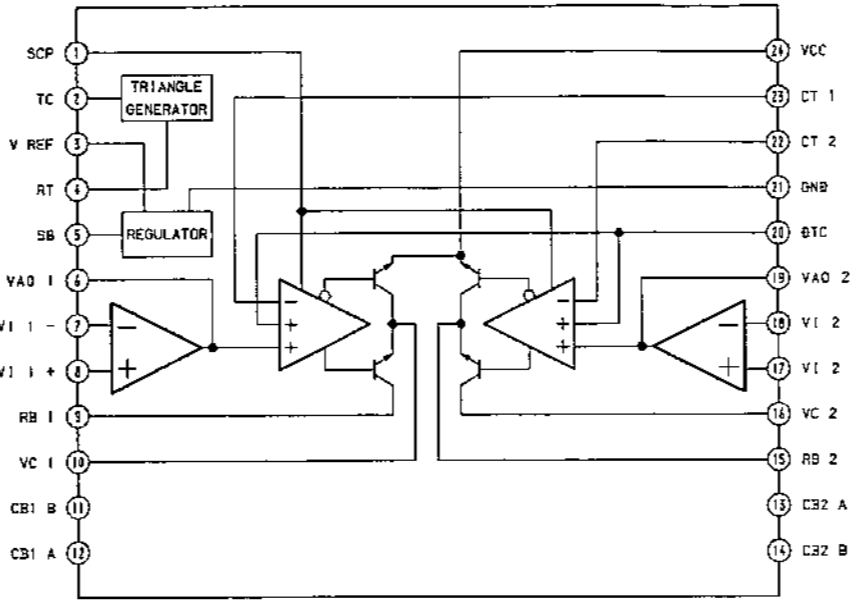

IC503 MCD002BM

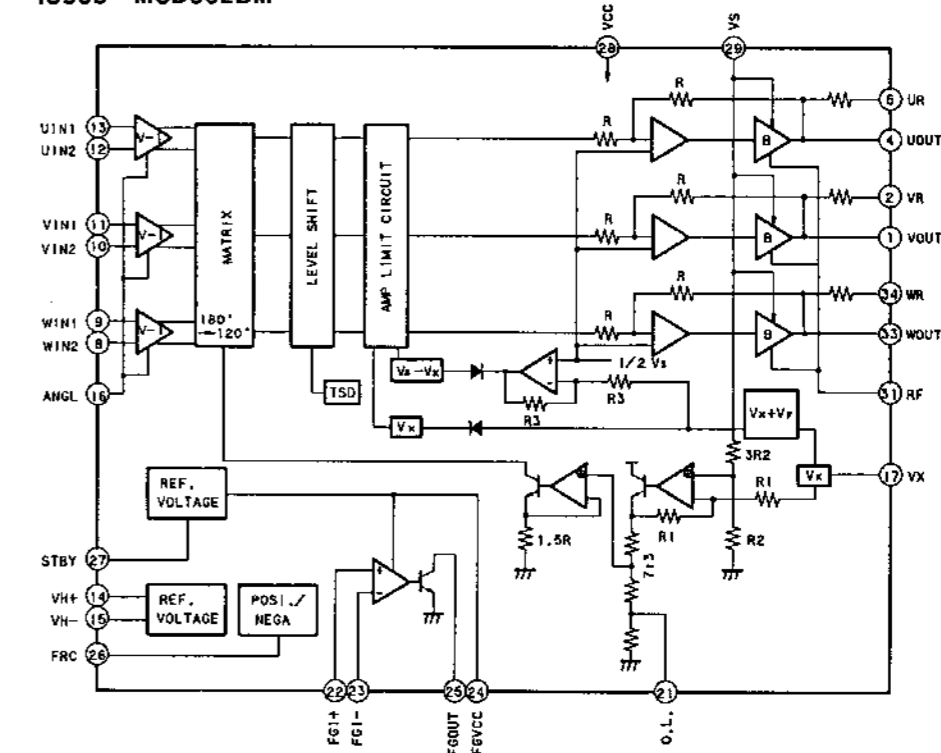

IC305 SM5840BS

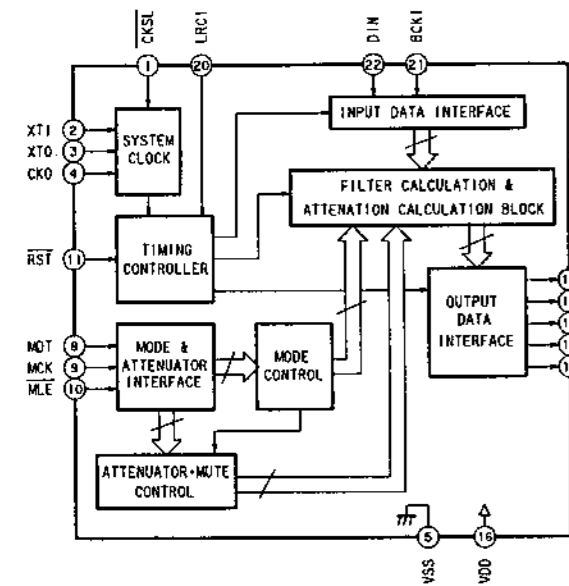

IC311 PCM68U

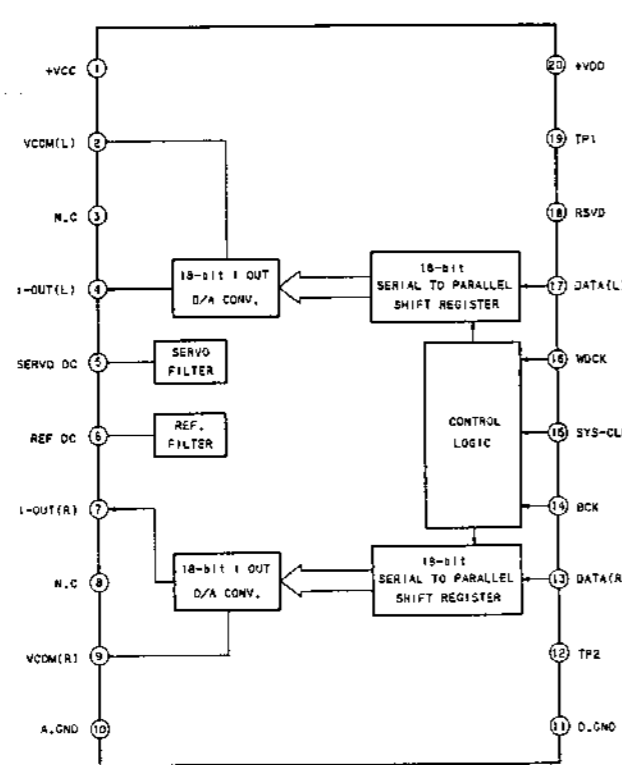

IC502 CXA8022N

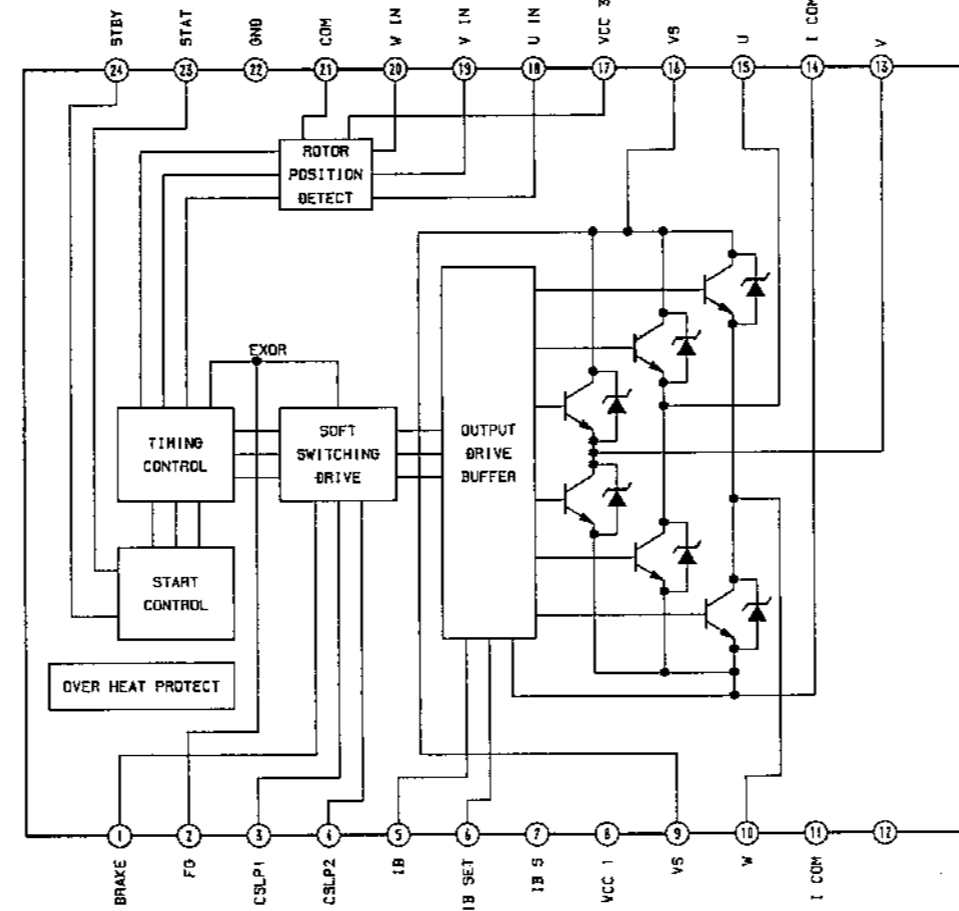

IC504 MM1138XQ

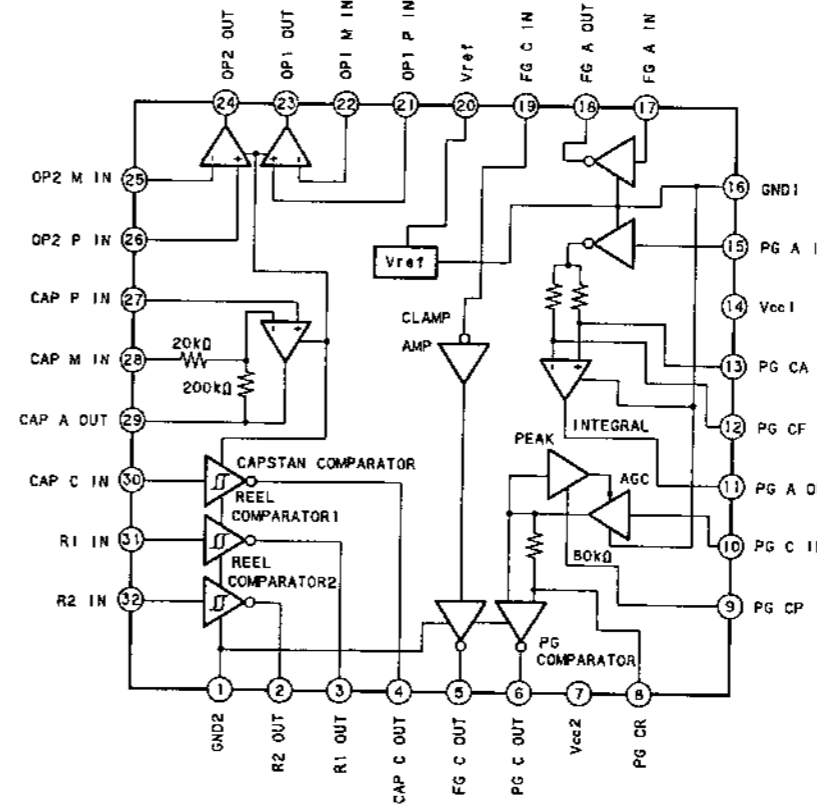

IC507 TK10502

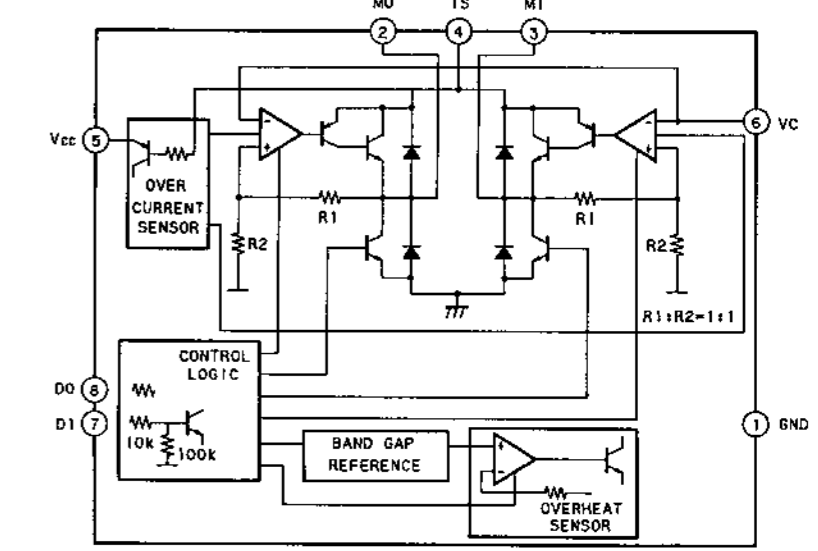

3-2. SEMICONDUCTOR LEAD LAYOUTS

AK5344-VS-E1

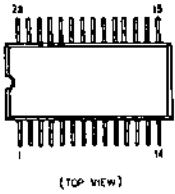

**NJM2100V
NJM3416V
NJM4560M
TK15021MTL**

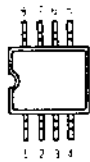

TK11245TL

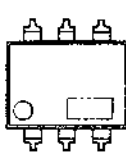

XN6501

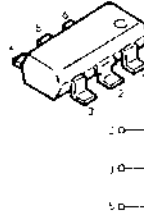

MA728

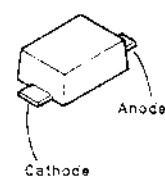

**CXA8022N
MB3796PFV-G-
BND-ER**

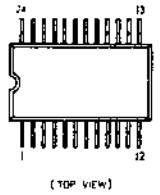

DTC113ZU

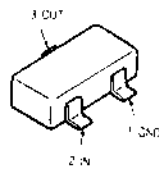

XP6501

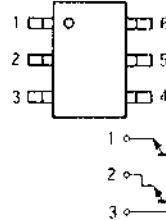

**RB420D
RD5.6M-B2
SB07-03C**

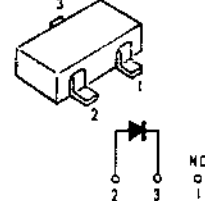

**CXD2605R
CXP80524-078R**

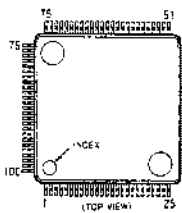

**NJM2112V (TE2)
TK10502MT1**

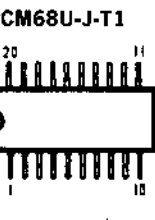

DTC114YK

- UN5111
- UN5114
- UN5211
- UN5212
- UN5214
- UN5215
- 2SA1162-G
- 2SA1586-YG
- 2SB624-BV345
- 2SC1623-L5L6
- 2SC2712-YG
- 2SD596-DV5
- 2SD1328-S
- 2SD1819A-R

**2SB1121-ST
2SB1121-T
2SD999-CLCK**

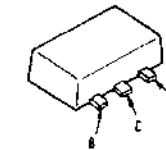

**SB007T03C
1SS226**

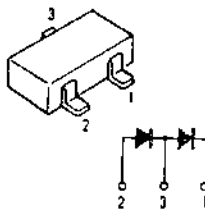

CXK58257ATM-12LB

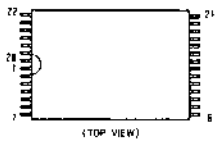

PCM68U-J-T1



RH5RE40AA-T1

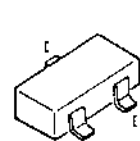

**GL453S
MA786WK**

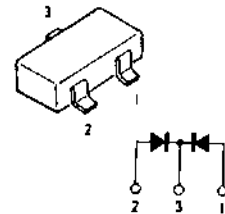

CL-170PG-CD-T

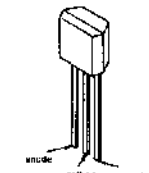

MCD002BM-TLM

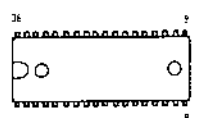

**RN5VL33AA-T1
SC7S04F**

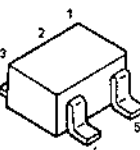

XN4315

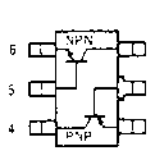

**MA141WK
1SS181**

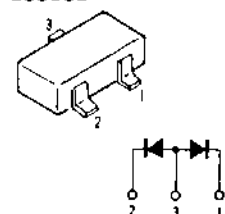

MM1138XQ

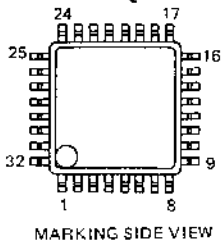

SM5840BS

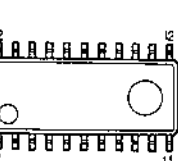

XN4504

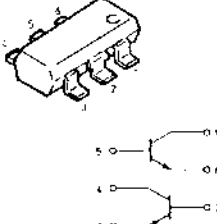

MA713

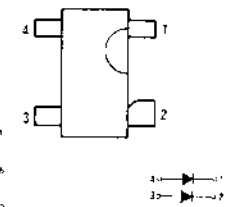

3-3. PRINTED WIRING BOARDS • Refer to page 18 for Semiconductor Lead Layouts.

• Semiconductor Location

Ref. No.	Location	Ref. No.	Location
D102	C-3	Q106	F-26
D103	E-2	Q202	F-26
D104	E-26	Q206	F-26
D202	C-3	Q301	G-4
D203	F-26	Q302	E-24
D204	E-26	Q303	F-24
D301	C-27	Q304	F-24
D303	F-5	Q305	G-5
D331	F-25	Q306	J-2
D332	C-24	Q307	G-5
D340	F-24	Q308	C-2
D341	C-25	Q309	G-4
D501	H-20	Q311	F-3
D502	H-19	Q312	F-24
D503	I-19	Q313	G-4
D505	D-5	Q314	C-4
D506	D-10	Q316	C-24
D507	D-9	Q317	F-3
D508	D-9	Q318	F-3
D509	C-9	Q331	F-25
D510	C-9	Q332	F-25
D511	E-10	Q333	C-25
D512	D-8	Q334	C-24
D515	D-7	Q353	C-24
D516	D-7	Q354	C-25
D517	D-6	Q355	D-25
D1001	H-29	Q356	D-25
(D1001)	H-13	Q357	F-25
D1003	I-29	Q361	F-25
D2001	K-22	Q362	E-24
		Q363	J-3
		Q364	I-3
		Q365	F-2
		Q367	C-5
IC301	H-26	Q501	H-20
IC302	E-27	Q502	H-19
IC303	H-25	Q503	F-7
IC304	H-24	Q504	D-8
IC305	C-22	Q505	D-7
IC308	D-26	Q508	J-6
IC311	C-23	Q509	I-6
IC313	H-4	Q512	C-16
IC314	D-24	Q513	A-19
IC315	E-25	Q514	F-9
IC501	G-19	Q515	D-17
IC502	G-7	Q516	D-18
IC503	H-23	Q518	I-23
IC504	G-8	Q519	C-8
IC505	F-8	Q1001	I-11
IC506	E-22	Q1002	I-14
IC507	H-21	Q2001	K-19
IC508	D-20	Q2002	L-22
IC509	E-19	Q2003	L-22
IC510	D-8	Q2004	K-22
IC511	E-9	Q3001	E-18
IC2001	K-22		
Q001	C-7		
Q102	E-27		

(): FLEXIBLE BOARD

Note:

- : parts extracted from the conductor side.
- : parts mounted on the conductor side.
- : Pattern on the side which is seen.
- : Pattern of the rear side.

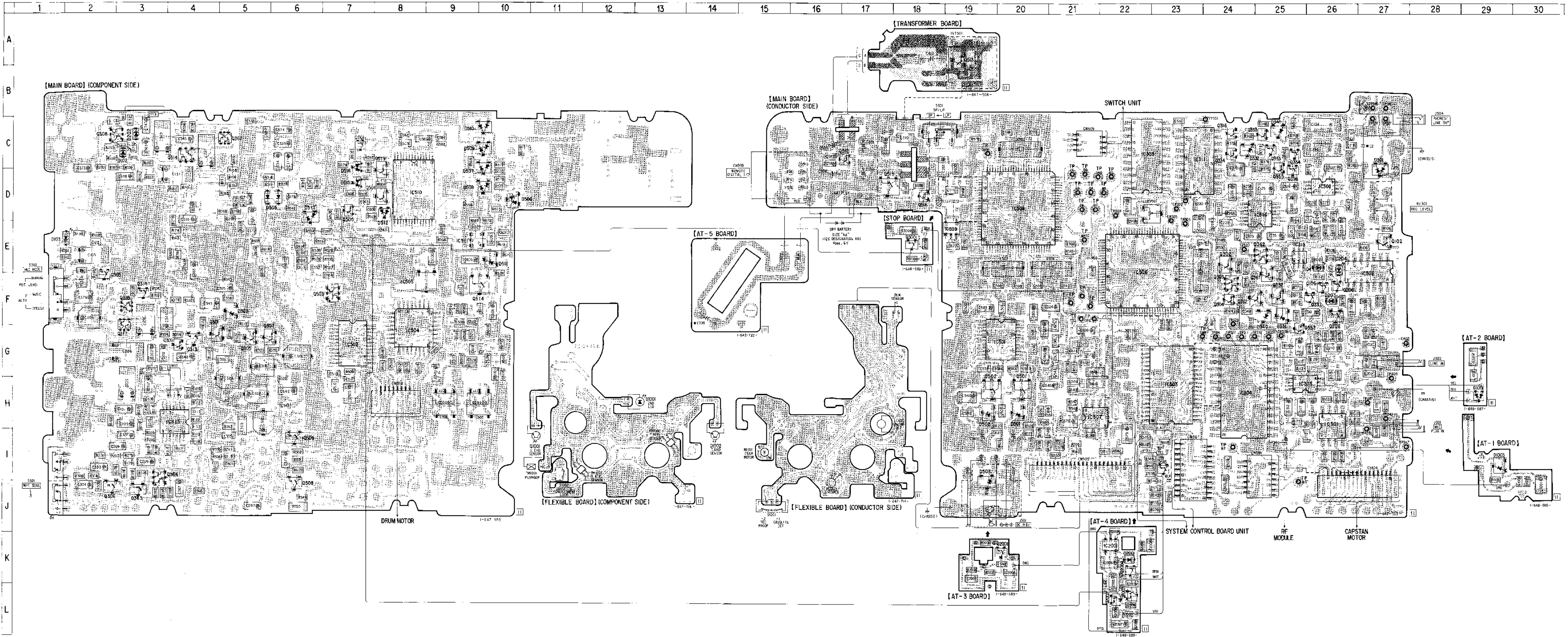

3-4. SCHEMATIC DIAGRAM—ANALOG SECTION— Refer to page 15 for IC Block Diagrams. Refer to page 31 for Waveforms.

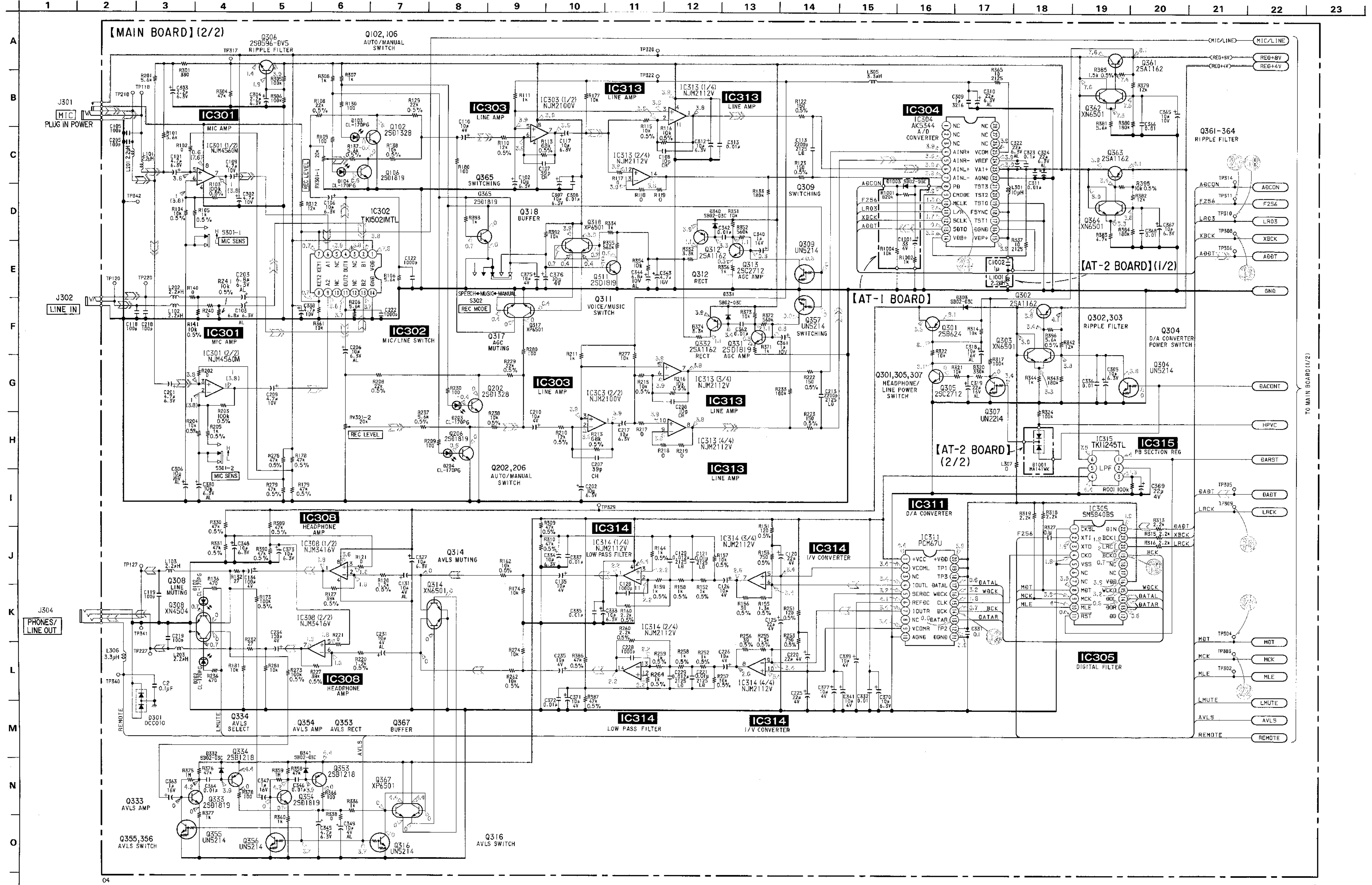

- Note:**
- All capacitors are in μF unless otherwise noted. μF : μF , 50WV or less are not indicated except for electrolytics and tantalums.
 - All resistors are in Ω and $\frac{1}{2}\text{W}$ or less unless otherwise specified.
 - % : indicates tolerance.
 - : B+ line
 - Power voltage is dc 6V a.c. for regulated dc power supply from battery terminal.
 - Volts and waveforms are dc with respect to ground under no-signal conditions. no mark : PLAY () : REC
 - Waveforms are taken with a VOM (Input Impedance 10M Ω). Voltage variations may be noted due to normal production tolerances.
 - Waveforms are taken with an oscilloscope. Voltage variations may be noted due to normal production tolerances.
 - Circled numbers refer to waveforms.
 - Signal path.
 - : PB
 - : REC

3-5. SCHEMATIC DIAGRAM—MAIN SECTION— Refer to page 15 for IC Block Diagrams. Refer to page 31 for Waveforms.

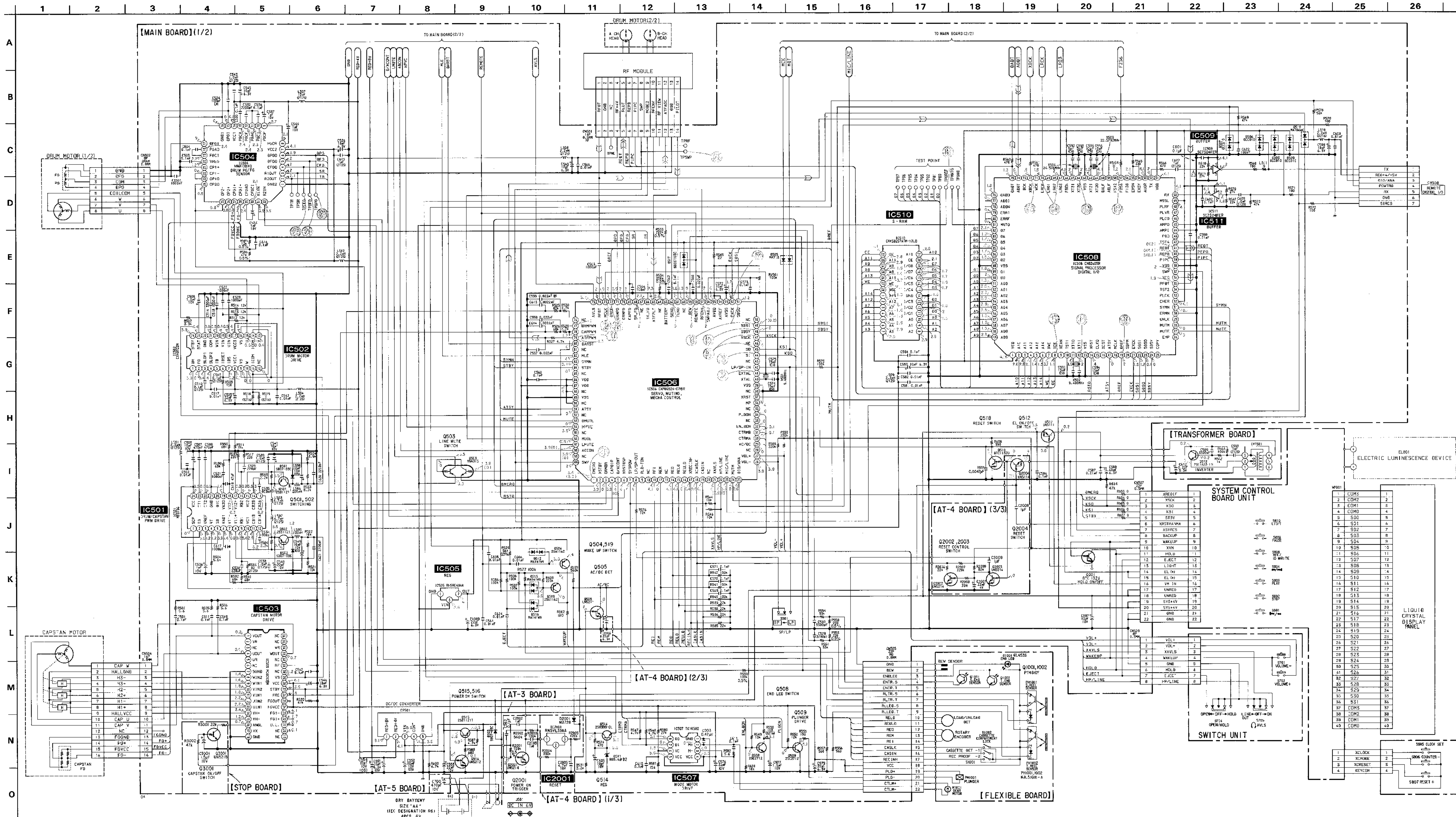

Note:

- All capacitors are in μF unless otherwise noted. pF : μF
- 50WV or less are not indicated except for electrolytics and tantalums.
- All resistors are in Ω and $\frac{1}{2}$ W or less unless otherwise specified.
- % : indicates tolerance.
- \circ : \circ : Lins
- Power voltage is dc 5V and fed with regulated dc power supply from battery terminal.
- Voltage and waveforms are dc with respect to ground under no signal conditions.
- no mark : PB () : REC
- Voltages are taken with a VOM (input impedance 10M Ω). Voltage variations may be noted due to normal production tolerances.
- Waveforms are taken with an oscilloscope. Voltage variations may be noted due to normal production tolerances.
- Circled numbers refer to waveforms.
- Signal path.
- \Rightarrow : PB
- \Rightarrow : REC

• Waveforms

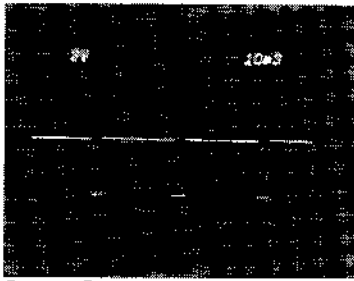

① IC506① 4Vp-p

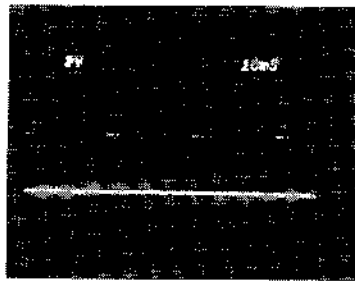

④ IC506④, ⑤ 4.0Vp-p

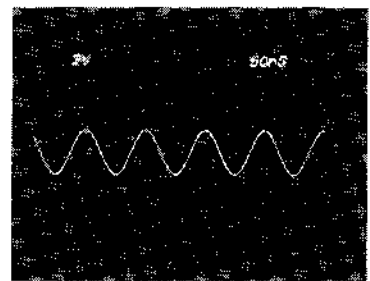

⑫ IC508⑫ 4.0Vp-p

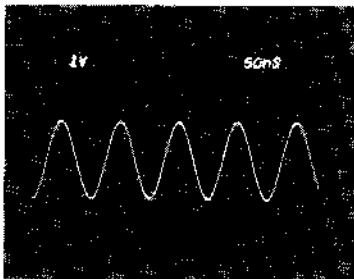

④① IC506④① 2.8Vp-p

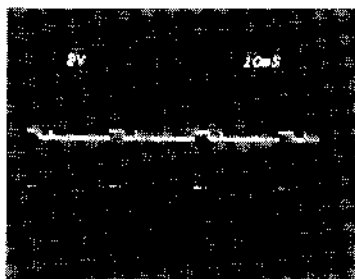

⑥② IC506⑥② 4.0Vp-p

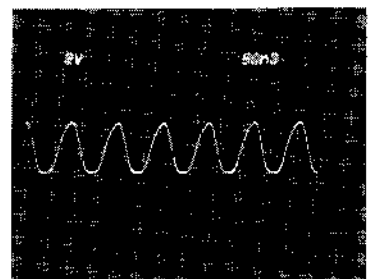

⑥③ IC508⑥③ 4.0Vp-p

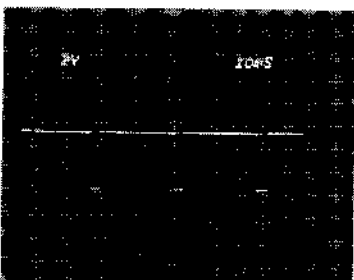

⑥④ IC506⑥④ 4.0Vp-p

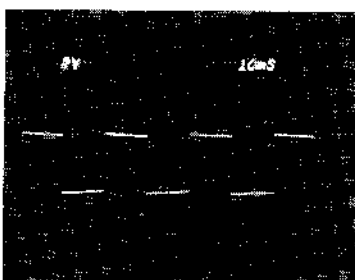

⑦② IC506⑦② } 4.0Vp-p
⑬② IC508⑬② }
TP (DREF)

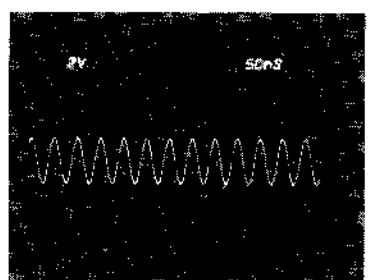

⑥⑤ IC508⑥⑤ 3.2Vp-p

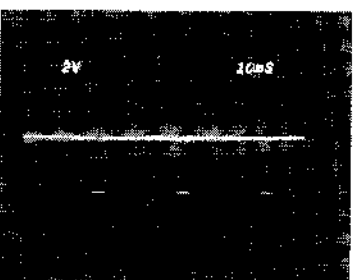

④⑦ IC506④⑦ 4.0Vp-p

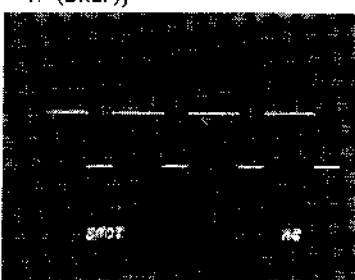

⑦③ IC506⑦③ 4.0Vp-p

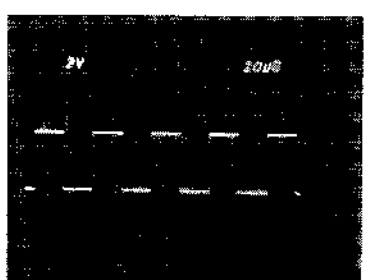

⑥⑦ IC508⑥⑦ 4.0Vp-p

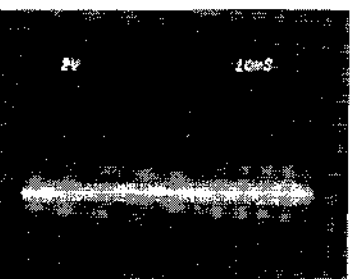

⑥⑧ IC506⑥⑧ 4.0Vp-p

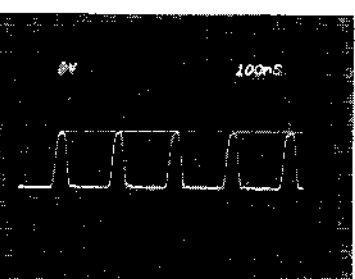

⑥⑧ IC508⑥⑧ 4.0Vp-p

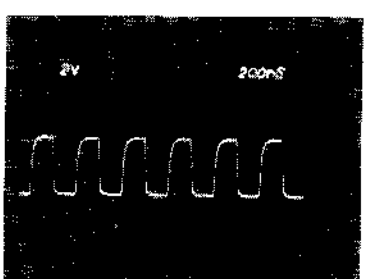

⑦② IC508⑦② 4.0Vp-p

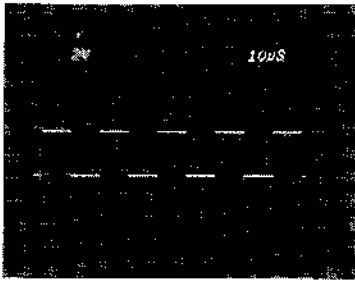

① TP309 (LRCK) 3.1Vp-p

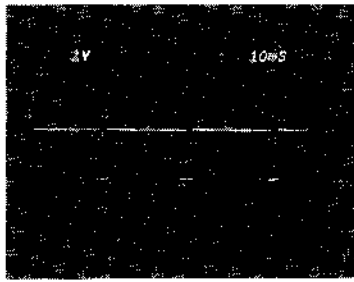

② IC305⑧ } 1.8Vp-p
TP304

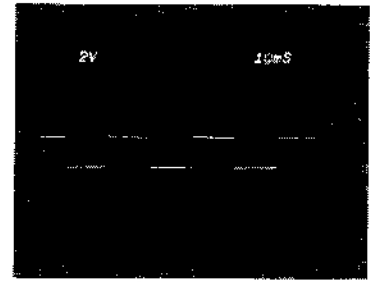

③ IC506⑩ } 2.2Vp-p
IC508⑳ }
TP (SWP)

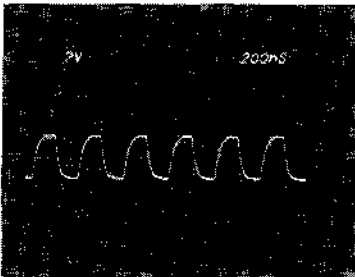

④ IC304⑫ } 3.0Vp-p
TP308 (XBCK)

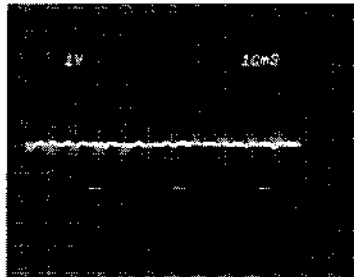

⑤ IC305⑨ } 1.8Vp-p
TP303

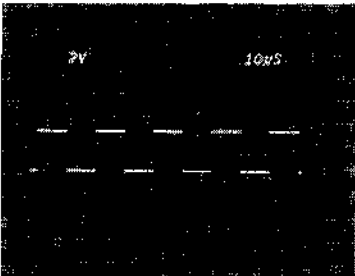

⑥ IC304⑪ } 2.7Vp-p
TP310

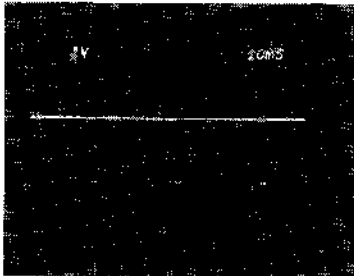

⑦ IC504⑤ } 2.2Vp-p
IC506⑦ }
TP (DPG)

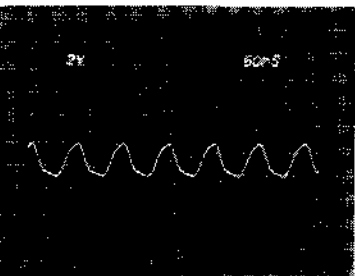

⑧ IC305⑬ } 2.4Vp-p
IC311⑱



⑨ IC504⑥ } 2.2Vp-p
IC506⑸ }
TP (DFG)

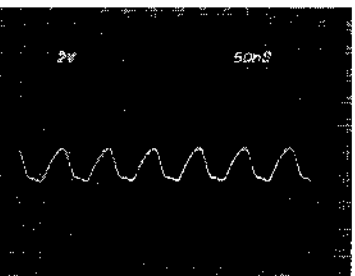

⑩ IC304⑬ } 2.4Vp-p
TP311

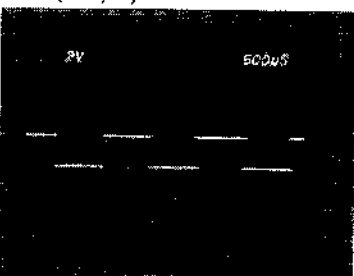

⑪ IC504④ } 2.1Vp-p
IC506⑹ }
TP (CFG)

SECTION 4 EXPLODED VIEWS

NOTE:

- The mechanical parts with no reference number in the exploded views are not supplied.
- Items marked "*" are not stocked since they are seldom required for routine service. Some delay should be anticipated when ordering these items.

- -XX and -X mean standardized parts, so they may have some difference from the original one.
- Color Indication of Appearance Parts

Example :
 KNOB, BALANCE (WHITE)... (RED)
 ↑ ↑
 Parts Color Cabinet's Color

- Hardware (# mark) list is given in the last of this parts list.

4-1. CABINET SECTION

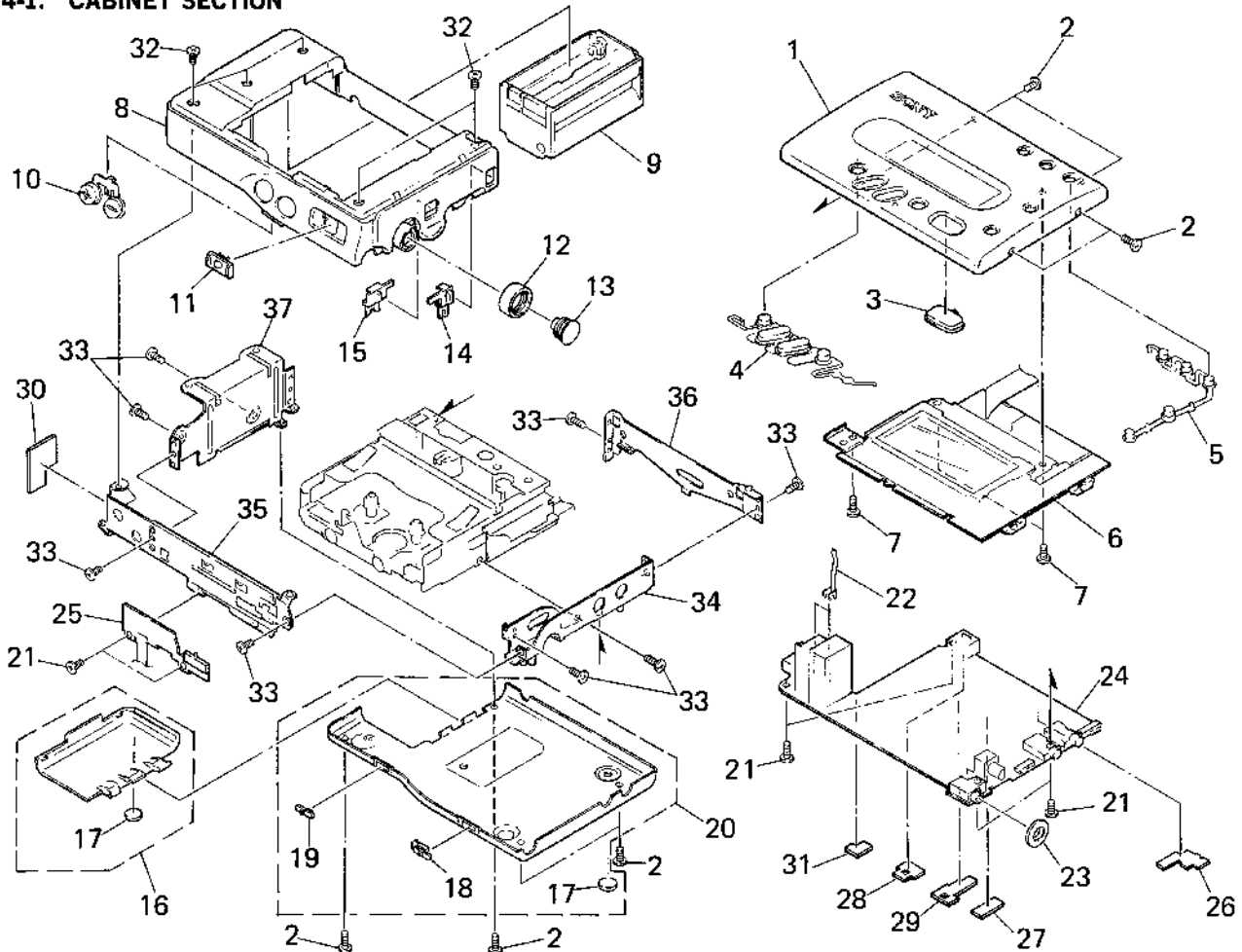

Ref. No.	Part No.	Description	Remark	Ref. No.	Part No.	Description	Remark
1	X-3366-464-1	LID ASSY. CASSETTE		19	3-387-465-01	KNOB (SP/LP)	
2	3-704-197-13	SCREW (M1.4X2.0), LOCKING		20	X-3366-463-1	PANEL ASSY. LOWER	
3	3-387-471-01	BUTTON (REC/ID WRITE)		21	3-335-797-01	SCREW (M1.4X2), TOOTHED LOCK	
4	3-387-470-01	BUTTON (⏮/⏪, STOP, PLAY, ⏩/⏭)		22	3-387-477-01	TERMINAL (MAIN), BATTERY	
5	X-3366-465-1	BUTTON (CLOCK, COUNTER, RESET, LIGHT, PAUSE) ASSY		23	3-387-466-01	RING, ORNAMENTAL (PHONES/LINE OUT)	
6	1-467-043-11	PC BOARD UNIT, SYSTEM CONTROL		24	A-3016-354-A	MAIN BOARD, COMPLETE	
7	3-318-382-61	SCREW (1.7X2.5), TAPPING		25	1-467-044-11	SWITCH UNIT (BLOCK TYPE)	
8	3-387-447-01	CABINET		* 26	1-648-686-11	AT-1 BOARD	
9	X-3366-462-1	CASE ASSY, BATTERY		* 27	1-648-687-11	AT-2 BOARD	
10	3-387-448-01	BUTTON (VOLUME +/-)		* 28	1-648-688-11	AT-3 BOARD	
11	X-3366-460-1	KNOB (HOLD) ASSY		* 29	1-648-689-11	AT-4 BOARD	
12	3-387-453-01	KNOB (REC. RING)		* 30	1-648-722-11	AT-5 BOARD	
13	3-387-452-01	KNOB (REC LEVEL)		* 31	1 648 989 11	STOP BOARD	
14	3 387 455 01	KNOB (MIC SENS)		32	3-349-825-81	SCREW, PRECISION	
15	3-387-454-01	KNOB (REC MODE)		33	3-704-197-01	SCREW (M1.4X1.6), LOCKING	
16	X 3366-466-1	LID ASSY. BATTERY CASE		* 34	X-3366-457-1	BRACKET (R) ASSY	
17	3-387-476-01	FOOT, RUBBER		* 35	X-3366-458-1	BRACKET (F) ASSY	
18	3-387-464-01	KNOB (AVLS)		* 36	3-387-446-01	BRACKET (B)	
				* 37	3-387-443-01	BRACKET (L)	

**4-2. CASSETTE HOLDER SECTION
(MT-D7-47)**

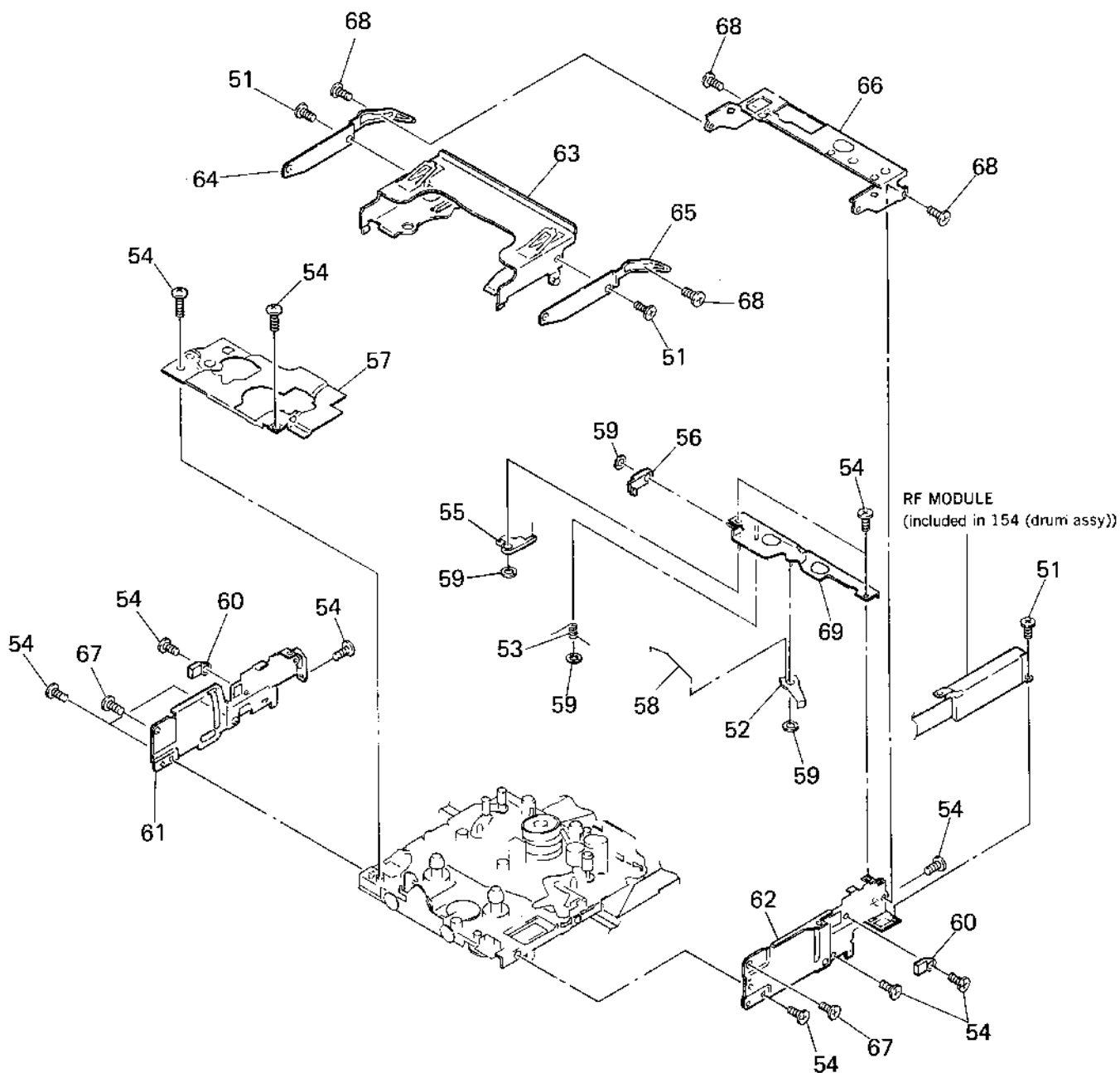

Ref. No.	Part No.	Description	Remark	Ref. No.	Part No.	Description	Remark
51	3-349-825-01	SCREW		* 61	X-3366-479-1	BRACKET (L) ASSY	
52	3-387-569-01	WIPER		62	3-387-573-01	BRACKET (R)	
53	3-363-266-01	SPRING, TORSION		63	X-3366-480-1	HOLDER (CASSETTE) ASSY	
54	3-389-523-08	SCREW (LOCK ACE) M1.4X1.6		64	3-387-571-01	LEVER (CASSETTE COMPARTMENT L)	
55	3-363-261-01	LEVER (B)		65	3-387-570-01	LEVER (CASSETTE COMPARTMENT R)	
56	3-363-260-01	LEVER (A)		66	3-387-572-01	HOLDER	
* 57	3-387-574-01	COVER (MD)		67	3-387-566-01	SCREW, STEP	
58	3-363-443-01	LINK		68	3-387-567-01	SCREW, STEP	
59	3-315-384-11	WASHER, STOPPER (T=0.25)		69	X-3366-478-1	COVER (TAPE PASS) ASSY	
60	3-387-565-01	HOLDER (END SENSOR)					

**4-3. MECHANISM DECK SECTION 1
(MT-D7-47)**

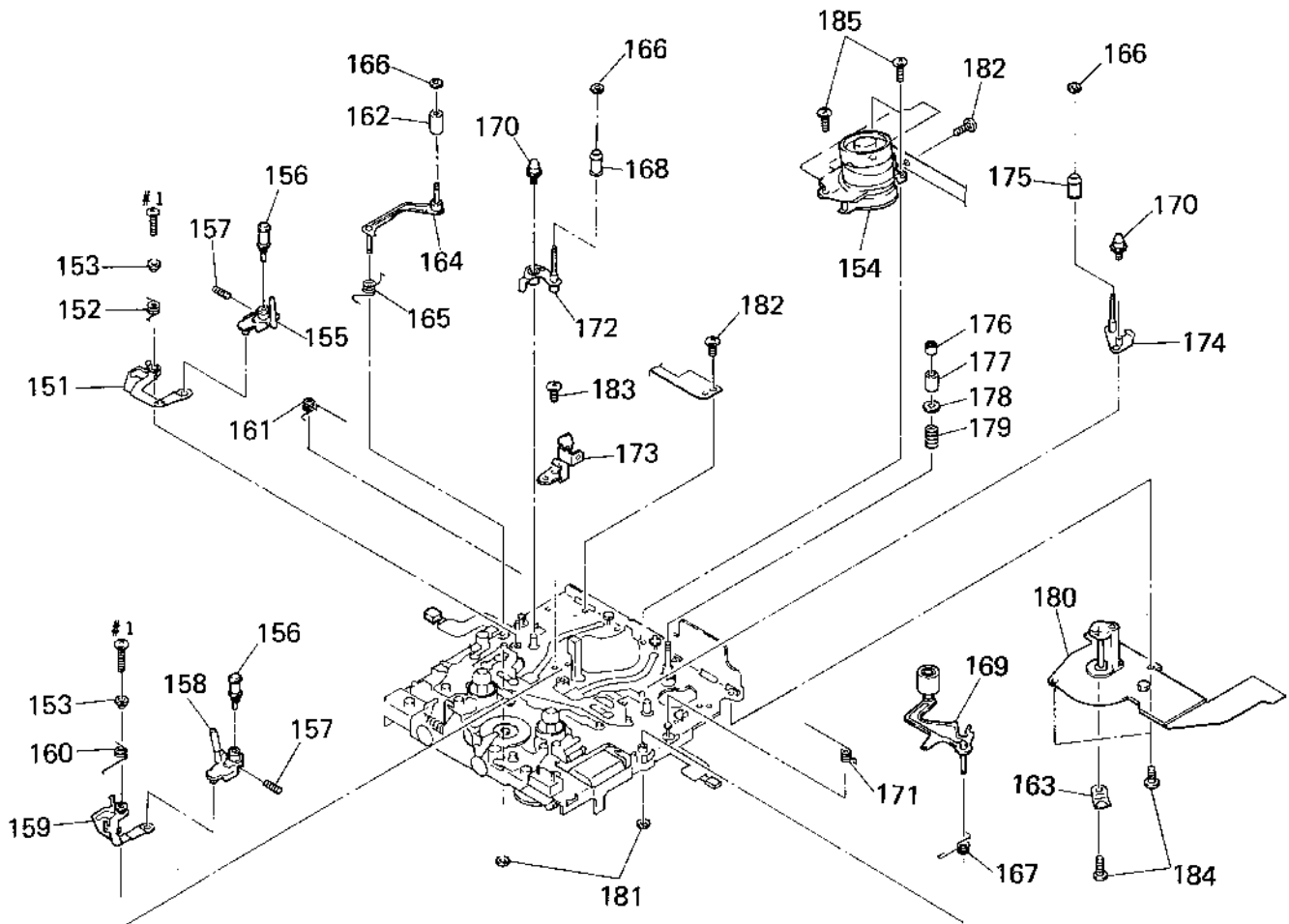

Ref. No.	Part No.	Description	Remark	Ref. No.	Part No.	Description	Remark
151	X-3344-945-1	LEVER (LOADING SA) ASSY		169	X-3362-201-1	ARM ASSY, PINCH ROLLER	
152	3-360-897-01	SPRING, TORSION		170	3-360-817-01	SHAFT (CASSETTE)	
153	3-354-247-03	SHAFT (LOADING B)		171	3-361-105-01	SPRING, TORSION	
154	X-4943-984-1	DRUM ASSY (INCLUDING RF MODULE)		172	X-3366-482-1	LEVER (SF) ASSY	
155	X-3364-968-1	GUIDE BLOCK (S) ASSY, SLANT		* 173	3-388-542-01	REINFORCEMENT (LED)	
156	X-3344-963-1	GUIDE (DIA. 4) ASSY, ROLLER		174	X-3366-483-1	LEVER (TF) ASSY	
157	3-366-945-01	SET-SCREW, SLOT M1.2X3		175	3-360-863-01	ROLLER (A), GUIDE	
158	X-3344-969-1	GUIDE BLOCK (T) ASSY, SLANT		176	3-337-605-01	NUT, ADJUSTMENT	
159	X-3344-943-1	LEVER (LOADING TA) ASSY		177	3-366-697-21	GUIDE (GA), FIXED	
160	3-360-895-01	SPRING, TORSION		178	3-337-677-01	FLANGE	
161	3-361-106-01	SPRING, TORSION		179	3-573-470-00	SPRING, COMPRESSION	
162	3-360-866-01	ROLLER (TENSION REGULATOR)		180	8-835-495-01	MOTOR, DC SCR Ø201A	
163	3-363-224-01	REINFORCEMENT (CAPSTAN MOTOR)		181	3-315-384-11	WASHER, STOPPER (T=0.25)	
164	X-3366-481-1	LEVER (TENSION REGULATOR A) ASSY		182	3-349-825-01	SCREW	
165	3-361-118-01	SPRING, TORSION		183	3-389-523-05	SCREW (LOCK ACE) M1.4X1.4	
166	3-315-414-00	WASHER		184	3-389-523-08	SCREW (LOCK ACE) M1.4X1.6	
167	3-361-115-01	SPRING, TORSION		185	3-389-523-22	SCREW (LOCK ACE) M1.4X2.5	
168	3-360-864-01	ROLLER (B), GUIDE					

**4-4. MECHANISM DECK SECTION 2
(MT-D7-47)**

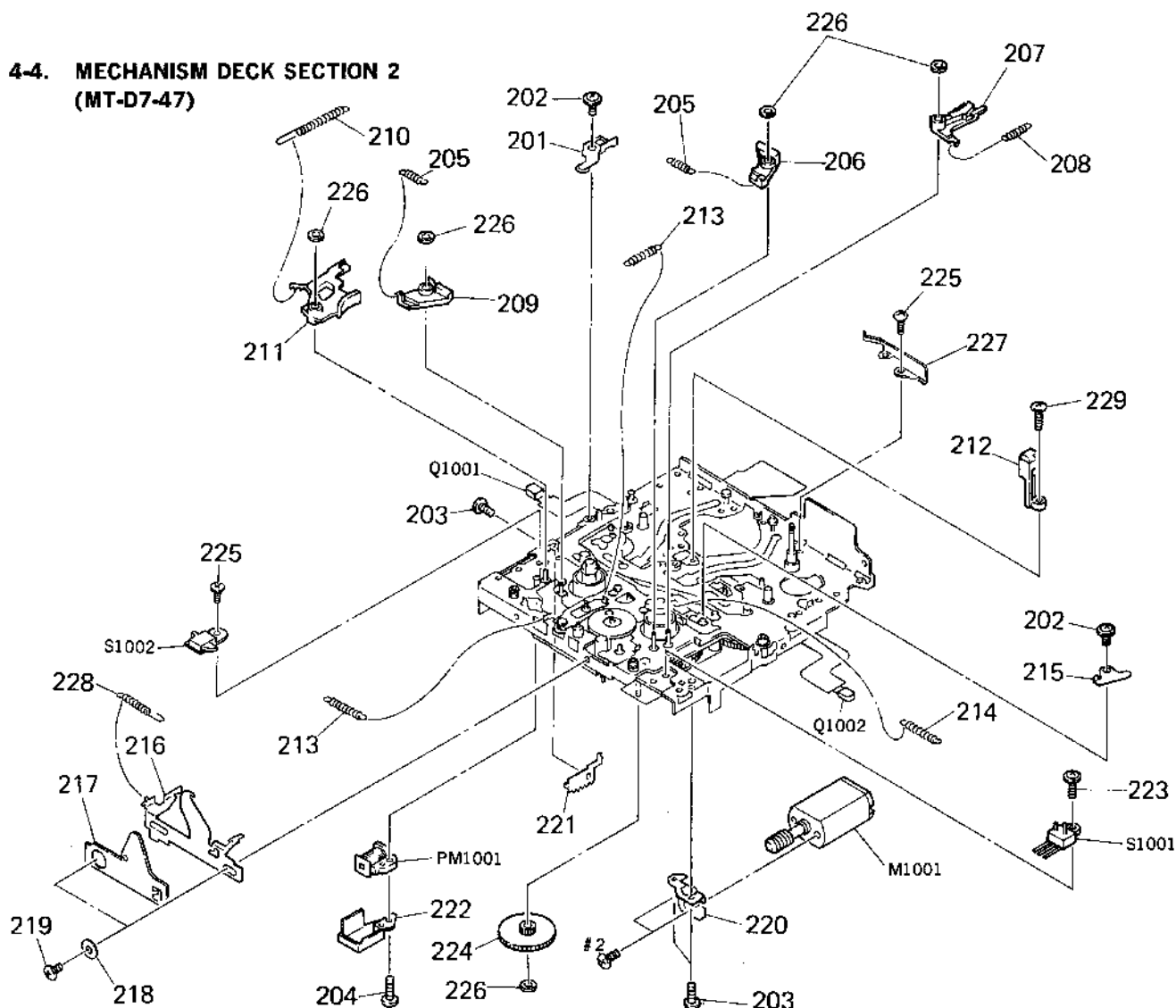

Ref. No.	Part No.	Description	Remark
201	X-3344-940-1	LEVER (TEN-REG B1) ASSY	
201	X-3362-179-1	LEVER ASSY	
* 201	X 3362 180 1	LEVER ASSY	
* 201	X-3362-181-1	LEVER ASSY	
202	3-703-502-91	SCREW	
203	3-389-523-05	SCREW (LOCK AGE) M1.4X1.4	
204	3-703-502-31	SCREW	
205	3-361-113-01	SPRING, TENSION	
206	X-3344-947-1	LEVER (BRAKE T) ASSY	
207	X-3344-946-1	LEVER (BRAKE RBT) ASSY	
208	3-361-111-01	SPRING, TENSION (40g/cm)	
208	3-367-610-01	SPRING, TENSION (35g/cm)	
208	3-367-611-01	SPRING, TENSION (30g/cm)	
208	3-369-815-01	SPRING, TENSION (45g/cm)	
208	3-369-816-01	SPRING, TENSION (49g/cm)	
208	3-369 817-01	SPRING, TENSION (55g/cm)	
209	X-3344-948-1	LEVER (BRAKE S) ASSY	
210	3-361-112-01	SPRING, TENSION	
211	X-3344-949-1	LEVER (TENSION REGULATOR) ASSY	
212	3-360-872-01	BRACKET (LED)	
213	3-361-107-01	SPRING, TENSION	
214	3-361-110-01	SPRING, TENSION	
215	X-3344 951 1	LEVER (R. BT RETURN A) ASSY	
* 215	X-3362-182-1	LEVER (R. BT RETURN B) ASSY	
215	X-4941-476-1	LEVER (R. BT RETURN C) ASSY	

Ref. No.	Part No.	Description	Remark
216	3-387-575-01	LEVER	
217	3-387-577-01	LEVER	
218	3-387-568-01	SHAFT	
219	3-704-246-01	SCREW (P1.4X1.6)	
220	3-387-562-01	BRACKET (MODE MOTOR)	
221	3-360-869-01	BRACKET (BT, SPRING)	
222	3-360-882-01	COVER (SOLENOID)	
223	3-703-502-21	SCREW	
224	3 360 829 01	GEAR (MODE B)	
225	3-349-825-01	SCREW	
226	3-315-384-11	WASHER, STOPPER (T=0.25)	
* 227	3-388-537-01	PLATE, GROUND	
228	3-387-564-01	SPRING, TENSION	
229	3-389-523-22	SCREW (LOCK AGE) M1.4X2.5	
M1001	1-698-104-11	MOTOR, DC (WITH GEAR)	
PM1001	1-454-602-11	SOLENOID, PLUNGER	
Q1001	8-729-925-30	END SENSOR PT4810F	
Q1002	8-729-925 30	END SENSOR PT4810F	
S1001	1-571-878-11	SWITCH, PUSH (2 KEY) (CASSETTE DET/REC PROOF)	
S1002	1-572-288-11	SWITCH, PUSH (AC POWER) (1 KEY) (CASSETTE CONTROL LOCK)	

**4-5. MECHANISM DECK SECTION 3
(MT-D7-47)**

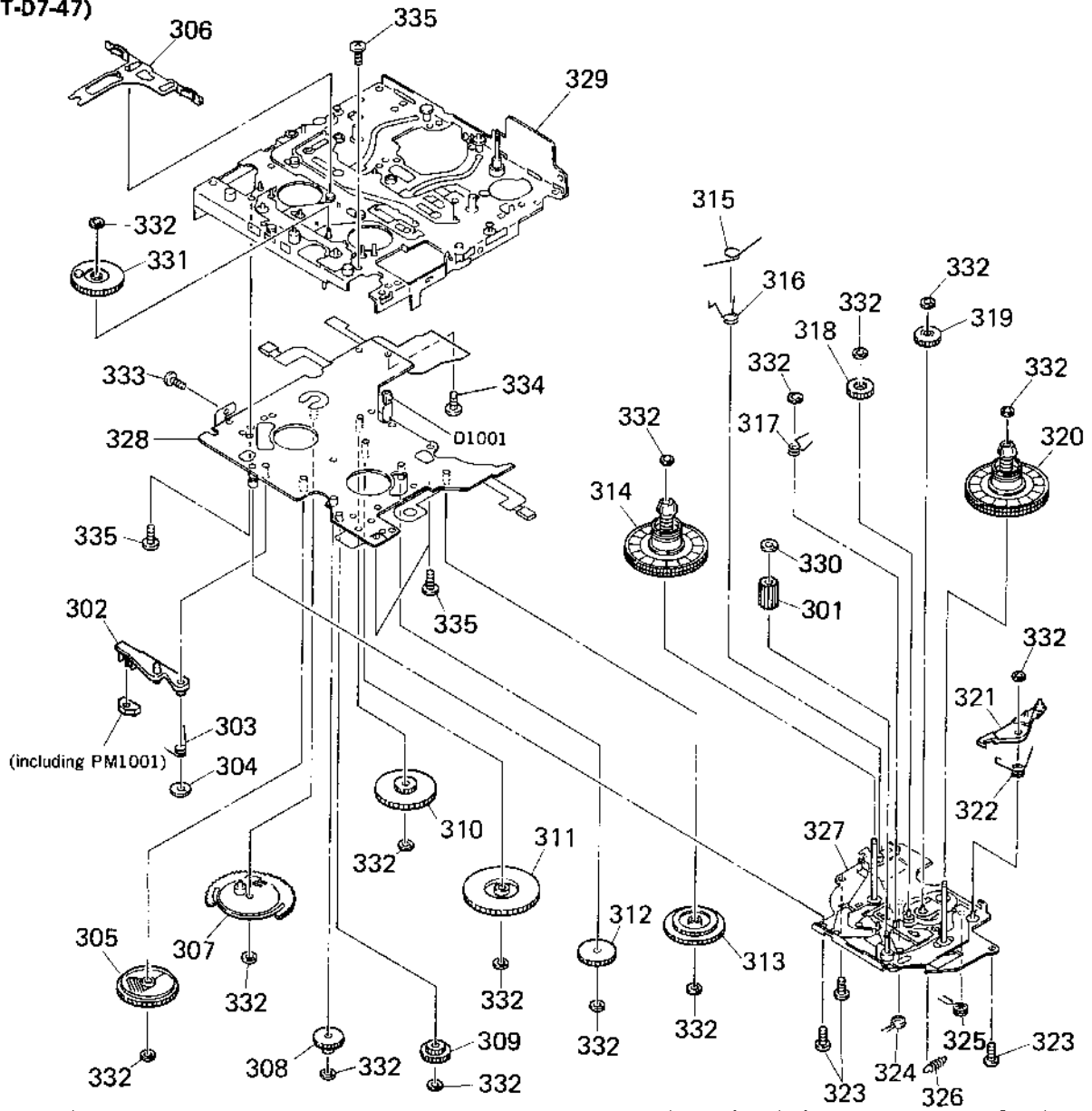

Ref. No.	Part No.	Description	Remark	Ref. No.	Part No.	Description	Remark
301	3-360-831-02	GEAR (MODE E)		319	3-360-825-01	GEAR (FR)	
302	X-3344-956-3	LEVER (SOLENOID) ASSY		320	X-3344-961-4	TABLE (T) ASSY, REEL	
303	3-361-117-01	SPRING, TORSION		321	3-360-849-02	LEVER (T LOCK)	
304	3-311-815-11	WASHER, POLYETHYLENE		322	3-361-114-01	SPRING, TORSION	
305	X-3344-966-3	GEAR (A) ASSY, CAM		323	3-703-502-01	SCREW	
306	X-3344-959-1	LEVER (SOFT BRAKE) ASSY		324	3-361-102-01	SPRING, TORSION	
307	X-3344-967-4	GEAR (LOADING) ASSY		325	3-360-896-03	SPRING, TORSION	
308	3-360-832-02	GEAR (MODE D)		326	3-370-921-02	SPRING, TENSION	
309	3-360-830-02	GEAR (MODE C)		327	X-3366-477-1	CHASSIS (REEL) ASSY	
310	3-360-828-01	GEAR (E)		328	X-4944-047-1	CHASSIS (SUB) ASSY	
311	3-360-883-02	GEAR (D)		329	X-3366-484-1	CHASSIS (MAIN) ASSY	*
312	3-360-827-01	GEAR (C)		330	3-321-813-01	WASHER, COTTER POLYETHYLENE	
313	3-360-824-01	GEAR (B)		331	3-360-886-03	GEAR (B), CAM	
314	X-3344-960-4	TABLE (S) ASSY, REEL		332	3-315-384-11	WASHER, STOPPER (T=0.25)	
315	3-361-104-01	SPRING, TORSION		333	3-349-825-01	SCREW	
316	3-361-116-03	SPRING, TORSION		334	3-349-825-11	SCREW	
317	3-361-103-11	SPRING, TORSION		335	3-389-523-05	SCREW (LOCK ACE) M1.4X1.4	
318	3-360-826-02	GEAR (FF/REW)		D1001	8-719-988-42	LED GL453S	

SECTION 5 ELECTRICAL PARTS LIST

AT-1 **AT-2** **AT-3** **AT-4**

NOTE:

- Due to standardization, replacements in the parts list may be different from the parts specified in the diagrams or the components used on the set.
- -XX and -X mean standardized parts, so they may have some difference from the original one.
- RESISTORS
All resistors are in ohms.
METAL: Metal film resistor.
METAL OXIDE: Metal oxide-film resistor.
F: nonflammable

- Items marked "*" are not stocked since they are seldom required for routine service. Some delay should be anticipated when ordering these items.
- SEMICONDUCTORS
In each case, μ : μ , for example:
 μA ..: μA .. μPA ..: μPA ..
 μPB ..: μPB .. μPC ..: μPC .. μPD ..: μPD ..
- CAPACITORS
 μF : μF
- COILS
 μH : μH

When indicating parts by reference number, please include the board.

The components identified by mark Δ or dotted line with mark Δ are critical for safety. Replace only with part number specified.

Les composants identifiés par une marque Δ sont critiques pour la sécurité. Ne les remplacer que par une pièce portant le numéro spécifié.

- Abbreviations
JE : Tourist model
G : German model

Ref. No.	Part No.	Description	Remark
*	1-648-686-11	AT-1 BOARD *****	
		< CAPACITOR >	
G1001	1-135-318-11	TANTALUM CHIP 33 μ F	20% 4V
		< DIODE >	
D1003	8-719-975-43	DIODE RB420D	
		< RESISTOR >	
R1001	1-216-856-11	METAL CHIP 820K 5%	1/16W
R1002	1-216-821-11	METAL CHIP 1K 5%	1/16W
R1004	1-216-833-11	METAL CHIP 10K 5%	1/16W

*	1-648-687-11	AT 2 BOARD *****	
		< CAPACITOR >	
C1002	1-162-638-11	CERAMIC CHIP 1 μ F	16V
		< DIODE >	
D1001	8-719-404-35	DIODE MA141WK	
		< COIL >	
L1001	1-410-997-31	INDUCTOR CHIP 2.2 μ H	

*	1-648-688-11	AT-3 BOARD *****	
		< CAPACITOR >	
C562	1-165-319-11	CERAMIC CHIP 0.1 μ F	50V
C2002	1-164-234-11	CERAMIC CHIP 1 μ F	10V
C2003	1-164-234-11	CERAMIC CHIP 1 μ F	10V
		< TRANSISTOR >	
Q2001	8-729-402-93	TRANSISTOR UN5214	

Ref. No.	Part No.	Description	Remark
		< RESISTOR >	
R2001	1-216-699-11	METAL CHIP 100K 0.5%	1/10W
R2002	1-216-854-11	METAL CHIP 560K 5%	1/16W
R2003	1-216-845-11	METAL CHIP 100K 5%	1/16W

*	1-648-689-11	AT-4 BOARD *****	
		< CAPACITOR >	
C2005	1-135-210-11	TANTALUM CHIP 4.7 μ F	20% 10V
C2006	1-104-849-11	TANTALUM CHIP 22 μ F	20% 6.3V
C2007	1-104-847-11	TANTALUM CHIP 22 μ F	20% 4V
C2008	1-164-234-11	CERAMIC CHIP 1 μ F	10V
C2009	1-164-234-11	CERAMIC CHIP 1 μ F	10V
		< DIODE >	
D2001	8-719-421-27	DIODE MA728	
		< IC >	
IC2001	8-759-178-44	IC RN5VL33AA-T1	
		< TRANSISTOR >	
Q2002	8-729-402-93	TRANSISTOR UN5214	
Q2003	8-729-402-93	TRANSISTOR UN5214	
Q2004	8-729-402-96	TRANSISTOR UN5114	
		< RESISTOR >	
R2004	1-216-851-11	METAL CHIP 330K 5%	1/16W
R2005	1-216-844-11	METAL CHIP 82K 5%	1/16W
R2006	1-216-837-11	METAL CHIP 22K 5%	1/16W
R2007	1-216-849-11	METAL CHIP 220K 5%	1/16W
R2008	1-216-840-11	METAL CHIP 39K 5%	1/16W
		< RESISTOR >	
R2009	1-216-844-11	METAL CHIP 82K 5%	1/16W

AT-5

MAIN

TRANSFORMER

Ref. No.	Part No.	Description	Remark		
*	1-648-722-11	AT-5 BOARD *****			
		< CAPACITOR >			
C700	1-104-964 11	ELECT 470uF		10V	

	A-3016-354-A	MAIN BOARD, COMPLETE (INCLUDING TRANSFORMER BOARD) *****			
	3-387-477-01	TERMINAL (MAIN), BATTERY			
	3-708-377-01	SLIDER, SURF LOCK (16P)			
		< CAPACITOR >			
C2	1-164-159-11	CERAMIC 0.1uF		50V	
C003	1-164-005 11	CERAMIC CHIP 0.47uF		25V	
C101	1-135-181-21	TANTALUM CHIP 4.7uF	20%	6.3V	
C102	1-135-259-11	TANTALUM CHIP 10uF	20%	6.3V	
C103	1-128-019-11	ELECT CHIP 6.8uF		6.3V	
C105	1-162-953-11	CERAMIC CHIP 100PF	5%	50V	
C106	1-128-020-11	ELECT CHIP 10uF		6.3V	
C107	1-162-922-11	CERAMIC CHIP 39PF	5%	50V	
C108	1-162-915-11	CERAMIC CHIP 10PF	0.5PF	50V	
C109	1-135-210-11	TANTALUM CHIP 4.7uF	20%	10V	
C110	1-135-201-11	TANTALUM CHIP 10uF	20%	4V	
C113	1-164-161-11	CERAMIC CHIP 0.0022uF	10%	100V	
C117	1-135-259-11	TANTALUM CHIP 10uF	20%	6.3V	
C118	1-162-953-11	CERAMIC CHIP 100PF	5%	50V	
C119	1-162-953-11	CERAMIC CHIP 100PF	5%	50V	
C120	1-135-202-21	TANTALUM CHIP 22uF	20%	4V	
C121	1-164-480-11	CERAMIC CHIP 0.01uF	10%	50V	
C122	1-162-964-11	CERAMIC CHIP 0.001uF	10%	50V	
C125	1-135-202-21	TANTALUM CHIP 22uF	20%	4V	
C126	1-135-201-11	TANTALUM CHIP 10uF	20%	4V	
C128	1-163-009-11	CERAMIC CHIP 0.001uF	10%	50V	
C129	1-163-022-00	CERAMIC CHIP 0.012uF	10%	50V	
C131	1-128-014-11	ELECT CHIP 10uF		4V	
C134	1-104-848-11	TANTALUM CHIP 100uF	20%	4V	
C135	1-135-201-11	TANTALUM CHIP 10uF	20%	4V	
C201	1-135-181-21	TANTALUM CHIP 4.7uF	20%	6.3V	
C202	1-135-259-11	TANTALUM CHIP 10uF	20%	6.3V	
C203	1-128-019-11	ELECT CHIP 6.8uF		6.3V	
C205	1-162-953-11	CERAMIC CHIP 100PF	5%	50V	
C206	1-128-020-11	ELECT CHIP 10uF		6.3V	
C207	1-162-922-11	CERAMIC CHIP 39PF	5%	50V	
C208	1-162-915-11	CERAMIC CHIP 10PF	0.5PF	50V	
C209	1-135-210 11	TANTALUM CHIP 4.7uF	20%	10V	
C210	1-135-201-11	TANTALUM CHIP 10uF	20%	4V	

Ref. No.	Part No.	Description	Remark		
C213	1-164-161-11	CERAMIC CHIP 0.0022uF	10%	100V	
C217	1-135-259-11	TANTALUM CHIP 10uF	20%	6.3V	
C218	1-162-953-11	CERAMIC CHIP 100PF	5%	50V	
C219	1-162-953-11	CERAMIC CHIP 100PF	5%	50V	
C220	1-135-202-21	TANTALUM CHIP 22uF	20%	4V	
C221	1-164-480-11	CERAMIC CHIP 0.01uF	10%	50V	
C222	1-162-964-11	CERAMIC CHIP 0.001uF	10%	50V	
C225	1-135-202-21	TANTALUM CHIP 22uF	20%	4V	
C226	1-135-201-11	TANTALUM CHIP 10uF	20%	4V	
C228	1-163-009-11	CERAMIC CHIP 0.001uF	10%	50V	
C229	1-163-022-00	CERAMIC CHIP 0.012uF	10%	50V	
C231	1-128-014-11	ELECT CHIP 10uF		4V	
C234	1-104-848-11	TANTALUM CHIP 100uF	20%	4V	
C235	1-135-201-11	TANTALUM CHIP 10uF	20%	4V	
C302	1-135-210-11	TANTALUM CHIP 4.7uF	20%	10V	
C303	1-135-149-21	TANTALUM CHIP 2.2uF	20%	10V	
C304	1-135-149-21	TANTALUM CHIP 2.2uF	20%	10V	
C305	1-135-259-11	TANTALUM CHIP 10uF	20%	6.3V	
C306	1-124-779-00	ELECT CHIP 10uF	20%	16V	
C307	1-135-259-11	TANTALUM CHIP 10uF	20%	6.3V	
C308	1-162-970-11	CERAMIC CHIP 0.01uF	10%	25V	
C309	1-162-638-11	CERAMIC CHIP 1uF		16V	
C310	1-124-778-00	ELECT CHIP 22uF	20%	6.3V	
C311	1-162-970-11	CERAMIC CHIP 0.01uF	10%	25V	
C312	1-135-259-11	TANTALUM CHIP 10uF	20%	6.3V	
C313	1-162-970-11	CERAMIC CHIP 0.01uF	10%	25V	
C318	1-124-779-00	ELECT CHIP 10uF	20%	16V	
C319	1-126-395-11	ELECT 22uF	20%	16V	
C322	1-124-778-00	ELECT CHIP 22uF	20%	6.3V	
C323	1-164-156-11	CERAMIC CHIP 0.1uF		25V	
C324	1-124-778-00	ELECT CHIP 22uF	20%	6.3V	
C327	1-135-259-11	TANTALUM CHIP 10uF	20%	6.3V	
C330	1-135-157-21	TANTALUM CHIP 10uF	20%	6.3V	
C331	1-164-156-11	CERAMIC CHIP 0.1uF		25V	
C332	1-162-970-11	CERAMIC CHIP 0.01uF	10%	25V	
C333	1-135-259-11	TANTALUM CHIP 10uF	20%	6.3V	
C334	1-135-259-11	TANTALUM CHIP 10uF	20%	6.3V	
C335-337					
		1-162-970-11	CERAMIC CHIP 0.01uF	10%	25V
C338	1-135-210-11	TANTALUM CHIP 4.7uF	20%	10V	
C339	1-135-201-11	TANTALUM CHIP 10uF	20%	4V	
C340	1-135-091-00	TANTALUM CHIP 1uF	20%	16V	
C341	1-135-201-11	TANTALUM CHIP 10uF	20%	4V	
C342	1-162-970-11	CERAMIC CHIP 0.01uF	10%	25V	
C343	1-135-155-21	TANTALUM CHIP 4.7uF	10%	16V	
C344	1-135-156-21	TANTALUM CHIP 6.8uF	10%	10V	
C345	1-135-181-21	TANTALUM CHIP 4.7uF	20%	6.3V	
C346	1-162-970-11	CERAMIC CHIP 0.01uF	10%	25V	
C347	1-135-091-00	TANTALUM CHIP 1uF	20%	16V	

MAIN

TRANSFORMER

Ref. No.	Part No.	Description	Remark	Ref. No.	Part No.	Description	Remark
C348	1-135-259-11	TANTALUM CHIP	10uF 20% 6.3V	C538	1-164-234-11	CERAMIC CHIP	1uF 10V
C349	1-128-014-11	ELECT CHIP	10uF 4V	C539	1-164-234-11	CERAMIC CHIP	1uF 10V
C361	1-135-208-11	TANTALUM CHIP	1uF 20% 10V	C540	1-104-852-11	TANTALUM CHIP	22uF 20% 10V
C362	1-162-970-11	CERAMIC CHIP	0.01uF 10% 25V	C541	1-108-851-11	TANTALUM CHIP	10uF 20% 10V
C363	1-135-091-00	TANTALUM CHIP	1uF 20% 16V	C542	1-162-970-11	CERAMIC CHIP	0.01uF 10% 25V
C364	1-162-970-11	CERAMIC CHIP	0.01uF 10% 25V	C543	1-164-234-11	CERAMIC CHIP	1uF 10V
C365	1-104-851-11	TANTALUM CHIP	10uF 20% 10V	C544	1-135-208-11	TANTALUM CHIP	1uF 20% 10V
C366	1-162-970-11	CERAMIC CHIP	0.01uF 10% 25V	C545	1-135-259-11	TANTALUM CHIP	10uF 20% 6.3V
C367	1-135-259-11	TANTALUM CHIP	10uF 20% 6.3V	C546	1-135-259-11	TANTALUM CHIP	10uF 20% 6.3V
C368	1-162-970-11	CERAMIC CHIP	0.01uF 10% 25V	C547	1-164-156-11	CERAMIC CHIP	0.1uF 25V
C369	1-104-847-91	TANTALUM CHIP	22uF 20% 4V	C548-552			
C370	1-135-157-21	TANTALUM CHIP	10uF 20% 6.3V		1-127-558-11	ELECT(SOLID)	10uF 20% 10V
C371	1-135-201-11	TANTALUM CHIP	10uF 20% 4V	C553	1-104-852-11	TANTALUM CHIP	22uF 20% 10V
C372	1-162-970-11	CERAMIC CHIP	0.01uF 10% 25V	C554	1-127-558-11	ELECT(SOLID)	10uF 20% 10V
C373	1-135-259-11	TANTALUM CHIP	10uF 20% 6.3V	C557-559			
C374	1-135-091-00	TANTALUM CHIP	1uF 20% 16V	C557	1-164-227-11	CERAMIC CHIP	0.022uF 10% 25V
C375	1-135-157-21	TANTALUM CHIP	10uF 20% 6.3V	C560	1-164-156-11	CERAMIC CHIP	0.1uF 25V
C376	1-135-157-21	TANTALUM CHIP	10uF 20% 6.3V	C561	1-162-970-11	CERAMIC CHIP	0.01uF 10% 25V
C377	1-135-201-11	TANTALUM CHIP	10uF 20% 4V	C563	1-162-964-11	CERAMIC CHIP	0.001uF 10% 50V
C501	1-164-156-11	CERAMIC CHIP	0.1uF 25V	C564	1-162-953-11	CERAMIC CHIP	100PF 5% 50V
C502	1-162-970-11	CERAMIC CHIP	0.01uF 10% 25V	C565	1-135-259-11	TANTALUM CHIP	10uF 20% 6.3V
C503	1-164-156-11	CERAMIC CHIP	0.1uF 25V	C566	1-162-970-11	CERAMIC CHIP	0.01uF 10% 25V
C504	1-164-156-11	CERAMIC CHIP	0.1uF 25V	C567	1-164-156-11	CERAMIC CHIP	0.1uF 25V
C505	1-104-851-11	TANTALUM CHIP	10uF 20% 10V	C568	1-164-227-11	CERAMIC CHIP	0.022uF 10% 25V
C506	1-135-208-11	TANTALUM CHIP	1uF 20% 10V	C569-571			
C507	1-162-962-11	CERAMIC CHIP	470PF 10% 50V		1-164-156-11	CERAMIC CHIP	0.1uF 25V
C508	1-135-208-11	TANTALUM CHIP	1uF 20% 10V	C572	1-135-259-11	TANTALUM CHIP	10uF 20% 6.3V
C509	1-162-962-11	CERAMIC CHIP	470PF 10% 50V	C573	1-164-156-11	CERAMIC CHIP	0.1uF 25V
C510	1-164-004-11	CERAMIC CHIP	0.1uF 10% 25V	C574	1-162-917-11	CERAMIC CHIP	15PF 5% 50V
C511	1-164-156-11	CERAMIC CHIP	0.1uF 25V	C575	1-162-917-11	CERAMIC CHIP	15PF 5% 50V
C513	1-164-004-11	CERAMIC CHIP	0.1uF 10% 25V	C576	1-104-852-11	TANTALUM CHIP	22uF 20% 10V
C514	1-162-967-11	CERAMIC CHIP	0.0033uF 10% 50V	C577	1-135-148-21	TANTALUM CHIP	1.5uF 20% 10V
C517	1-162-970-11	CERAMIC CHIP	0.01uF 10% 25V	C578	1-162-967-11	CERAMIC CHIP	0.0033uF 10% 50V
C518	1-162-964-11	CERAMIC CHIP	0.001uF 10% 50V	C579	1-104-849-11	TANTALUM CHIP	22uF 20% 6.3V
C519	1-164-156-11	CERAMIC CHIP	0.1uF 25V	C580	1-162-967-11	CERAMIC CHIP	0.0033uF 10% 50V
C521-523				C581	1-162-970-11	CERAMIC CHIP	0.01uF 10% 25V
	1-162-964-11	CERAMIC CHIP	0.001uF 10% 50V	C582	1-162-970-11	CERAMIC CHIP	0.01uF 10% 25V
C524	1-162-927-11	CERAMIC CHIP	100PF 5% 50V	C583	1-135-259-11	TANTALUM CHIP	10uF 20% 6.3V
C525	1-104-849-11	TANTALUM CHIP	22uF 20% 6.3V	C584	1-164-156-11	CERAMIC CHIP	0.1uF 25V
C526	1-135-259-11	TANTALUM CHIP	10uF 20% 6.3V	C586	1-164-156-11	CERAMIC CHIP	0.1uF 25V
C528	1-162-960-11	CERAMIC CHIP	220PF 10% 50V	C587	1-162-970-11	CERAMIC CHIP	0.01uF 10% 25V
C529	1-162-960-11	CERAMIC CHIP	220PF 10% 50V	C588	1-104-755-11	ELECT	68uF 20% 6.3V
C530	1-164-156-11	CERAMIC CHIP	0.1uF 25V	C589	1-162-967-11	CERAMIC CHIP	0.0033uF 10% 50V
C532	1-162-966-11	CERAMIC CHIP	0.0022uF 10% 50V	C590	1-164-234-11	CERAMIC CHIP	1uF 10V
C533	1-135-208-11	TANTALUM CHIP	1uF 20% 10V	C591	1-162-917-11	CERAMIC CHIP	15PF 5% 50V
C534	1-162-964-11	CERAMIC CHIP	0.001uF 10% 50V	C592	1-162-910-11	CERAMIC CHIP	5PF 0.25PF 50V
C535	1-162-964-11	CERAMIC CHIP	0.001uF 10% 50V	C593	1-162-910-11	CERAMIC CHIP	5PF 0.25PF 50V
C536	1-164-156-11	CERAMIC CHIP	0.1uF 25V	C594	1-162-917-11	CERAMIC CHIP	15PF 5% 50V
C537	1-135-208-11	TANTALUM CHIP	1uF 20% 10V	C595	1-162-915-11	CERAMIC CHIP	10PF 0.5PF 50V

MAIN	TRANSFORMER
-------------	--------------------

Ref. No.	Part No.	Description	Remark
C596	1-162-915-11	CERAMIC CHIP	10PF 0.5PF 50V
C597	1-104-851-11	TANTALUM CHIP	10uF 20% 10V
C598	1-162-970-11	CERAMIC CHIP	0.01uF 10% 25V
C599	1-135-259-11	TANTALUM CHIP	10uF 20% 6.3V
C600	1-162-970-11	CERAMIC CHIP	0.01uF 10% 25V
C601	1-164-156-11	CERAMIC CHIP	0.1uF 25V
C602	1-164-156-11	CERAMIC CHIP	0.1uF 25V
C605	1-104-851-11	TANTALUM CHIP	10uF 20% 10V
C606	1-162-970-11	CERAMIC CHIP	0.01uF 10% 25V
C608	1-162-970-11	CERAMIC CHIP	0.01uF 10% 25V
C609	1-164-234-11	CERAMIC CHIP	1uF 10V
C610	1-164-156-11	CERAMIC CHIP	0.1uF 25V
C611	1-164-156-11	CERAMIC CHIP	0.1uF 25V
C612	1-125-507-11	DOUBLE LAYERS	0.22F 5.5V
C613	1-162-966-11	CERAMIC CHIP	0.0022uF 10% 50V
C614	1-162-966-11	CERAMIC CHIP	0.0022uF 10% 50V
C615	1-164-234-11	CERAMIC CHIP	1uF 10V
C616	1-164-156-11	CERAMIC CHIP	0.1uF 25V
C617	1-162-964-11	CERAMIC CHIP	0.001uF 10% 50V
C618	1-162-923-11	CERAMIC CHIP	47PF 5% 50V
C620	1-162-966-11	CERAMIC CHIP	0.0022uF 10% 50V
C621	1-162-979-11	CERAMIC CHIP	0.0027uF 10% 50V
C622	1-162-953-11	CERAMIC CHIP	100PF 5% 50V
C624	1-162-970-11	CERAMIC CHIP	0.01uF 10% 25V
C627	1-164-234-11	CERAMIC CHIP	1uF 10V
C1000	1-104-849-11	TANTALUM CHIP	22uF 20% 6.3V
C2001	1-163-009-11	CERAMIC CHIP	0.001uF 10% 50V
< CONNECTOR >			
CN501	1-750-374-11	CONNECTOR, FPC 14P	
* CN502	1-691-419-11	HOUSING, CONNECTOR 8P	
CN504	1-569-530-11	HOUSING, CONNECTOR 16P	
* CN505	1-691-798-11	HOUSING, CONNECTOR 22P	
CN507	1-750-375-11	CONNECTOR, FPC 22P	
CN508	1-750-377-11	SOCKET, CONNECTOR 7P (REMOTE DIGITAL I/O)	
CN509	1-750-373-11	CONNECTOR, FPC 8P	
< DC/DC CONVERTER UNIT >			
CP501	1-467-045-11	CONVERTER UNIT, DC/DC	
< DIODE >			
D102-104	8-719-033-14	LED CL-170PG-CD-T	
D202-204	8-719-033-14	LED CL-170PG-CD-T	
D301	8-719-800-76	DIODE 1SS226	
D303	8-719-975-43	DIODE RB420D	
D331	8-719-975-43	DIODE RB420D	

Ref. No.	Part No.	Description	Remark
D332	8-719-975-43	DIODE RB420D	
D340	8-719-975-43	DIODE RB420D	
D341	8-719-975-43	DIODE RB420D	
D501-503	8-719-980-38	DIODE SB07-03C	
D505	8-719-404-16	DIODE MA713	
D506 509	8-719-800-76	DIODE 1SS226	
D510	8-719-026-26	DIODE MA786WK	
D511	8-719-105-91	DIODE RD5.6M-B2	
D512	8-719-404-35	DIODE MA141WK	
D515	8-719-820-05	DIODE 1SS181	
D516	8-719-820-05	DIODE 1SS181	
D517	8-719-989-73	DIODE SB007T03C	
< IC >			
IC301	8-759-745-64	IC NJM4560M	
IC302	8-759-161-76	IC TK15021MTL	
IC303	8-759-097-92	IC NJM2100V	
IC304	8-759-161-74	IC AK5344-VS-E1	
IC305	8-759-501-41	IC SM5840BS	
IC308	8-759-058-41	IC NJM3416V	
IC311	8-759-178-41	IC PCM68U-J-T1	
IC313	8-759-161-75	IC NJM2112V (TE2)	
IC314	8-759-161-75	IC NJM2112V (TE2)	
IC315	8-759-168-90	IC TK11245TL	
IC501	8-759-094-01	IC MB3796PFV-G-BND-ER	
IC502	8-759-094-02	IC CXA8022N	
IC503	8-759-164-58	IC MCD002BM-TLM	
IC504	8-759-159-76	IC MM1138XQ	
IC505	8-759-168-66	IC RHSRE40AA-T1	
IC506	8-752-843-07	IC CXP80524-078R	
IC507	8-759-159-77	IC TK10502MT1	
IC508	8-752-352-24	IC CXD2605R	
IC509	8-759-031-84	IC SC7SU4F	
IC510	8-752-343-47	IC CXK58257ATM-12LB	
IC511	8-759-031-84	IC SC7SD4F	
< TRANSFORMER >			
IVT501	1-423-601-11	TRANSFORMER, OSCILLATION	
< JACK >			
J301	1-750-369-11	JACK (MIC)	
J302	1-750-370-11	JACK (LINE IN)	
J304	1-750-372-11	JACK (PHONES/LINE OUT)	
J501	1-750-368-11	JACK, DC (POLARITY UNIFIED TYPE) (DC IN 6V)	

MAIN TRANSFORMER

Ref. No.	Part No.	Description	Remark
< COIL >			
L101-103	1-410-997-31	INDUCTOR CHIP 2.2uH	
L201-203	1-410-997-31	INDUCTOR CHIP 2.2uH	
L301	1-412-006-31	INDUCTOR CHIP 10uH	
L305	1-410-999-11	INDUCTOR CHIP 3.3uH	
L306	1-410-999-11	INDUCTOR CHIP 3.3uH	
L307	1-216-295-00	METAL CHIP 0 5%	1/10W
L501	1-410-997-31	INDUCTOR CHIP 2.2uH	
L502	1-412-002-31	INDUCTOR CHIP 4.7uH	
L503	1-412-002-31	INDUCTOR CHIP 4.7uH	
L504	1-410-997-31	INDUCTOR CHIP 2.2uH	
L505	1-414-213-21	INDUCTOR 100uH	
L506	1-414-214-21	INDUCTOR 200uH	
L507	1-412-006-31	INDUCTOR CHIP 10uH	
L508	1-410-997-31	INDUCTOR CHIP 2.2uH	
L509	1-410-997-31	INDUCTOR CHIP 2.2uH	
L510	1-410-196-11	INDUCTOR CHIP 2.2uH	
L511	1-216-295-00	METAL CHIP 0 5%	1/10W
L512	1-410-997-31	INDUCTOR CHIP 2.2uH	
< TRANSISTOR >			
Q001	8-729-924-62	TRANSISTOR DTC113ZU	
Q102	8-729-400-55	TRANSISTOR 2SD1328-S	
Q106	8-729-402-32	TRANSISTOR 2SD1819A-R	
Q202	8-729-400-55	TRANSISTOR 2SD1328-S	
Q206	8-729-402-32	TRANSISTOR 2SD1819A-R	
Q301	8-729-141-48	TRANSISTOR 2SB624-BV345	
Q302	8-729-216-22	TRANSISTOR 2SA1162-G	
Q303	8-729-402-19	TRANSISTOR XN6501	
Q304	8-729-402-93	TRANSISTOR UN5214	
Q305	8-729-230-49	TRANSISTOR 2SC2712-YG	
Q306	8-729-159-65	TRANSISTOR 2SD596-DV5	
Q307	8-729-900-52	TRANSISTOR DTC114YK	
Q308	8-729-425-18	TRANSISTOR XN4504	
Q309	8-729-402-93	TRANSISTOR UN5214	
Q311	8-729-402-32	TRANSISTOR 2SD1819A-R	
Q312	8-729-216-22	TRANSISTOR 2SA1162-G	
Q313	8-729-230-49	TRANSISTOR 2SC2712-YG	
Q314	8-729-402-19	TRANSISTOR XN6501	
Q316	8-729-402-93	TRANSISTOR UN5214	
Q317	8-729-427-83	TRANSISTOR XP6501	
Q318	8-729-427-83	TRANSISTOR XP6501	
Q331	8-729-402-32	TRANSISTOR 2SD1819A-R	
Q332	8-729-216-22	TRANSISTOR 2SA1162-G	
Q333	8-729-402-32	TRANSISTOR 2SD1819A-R	
Q334	8-729-230-60	TRANSISTOR 2SA1586-YG	

Ref. No.	Part No.	Description	Remark
Q353	8-729-230-60	TRANSISTOR 2SA1586-YG	
Q354	8-729-402-32	TRANSISTOR 2SD1819A-R	
Q355-357	8-729-402-93	TRANSISTOR UN5214	
Q361	8-729-216-22	TRANSISTOR 2SA1162-G	
Q362	8-729-402-19	TRANSISTOR XN6501	
Q363	8-729-216-22	TRANSISTOR 2SA1162-G	
Q364	8-729-402-19	TRANSISTOR XN6501	
Q365	8-729-402-32	TRANSISTOR 2SD1819A-R	
Q367	8-729-427-83	TRANSISTOR XP6501	
Q501	8-729-820-86	TRANSISTOR 2SB1121-ST	
Q502	8-729-820-86	TRANSISTOR 2SB1121-ST	
Q503	8-729-422-18	TRANSISTOR XN4315	
Q504	8-729-216-22	TRANSISTOR 2SA1162-G	
Q505	8-729-015-76	TRANSISTOR UN5211	
Q508	8-729-230-49	TRANSISTOR 2SC2712-YG	
Q509	8-729-230-49	TRANSISTOR 2SC2712-YG	
Q512	8-729-015-74	TRANSISTOR UN5111	
Q513	8-729-120-28	TRANSISTOR 2SC1623-L5L6	
Q514	8-729-140-75	TRANSISTOR 2SD999-CLCK	
Q515	8-729-805-26	TRANSISTOR 2SB1121-T	
Q516	8-729-402-45	TRANSISTOR UN5212	
Q518	8-729-924-62	TRANSISTOR DTC113ZU	
Q519	8-729-216-22	TRANSISTOR 2SA1162-G	
< RESISTOR >			
R001	1-216-845-11	METAL CHIP 100K 5%	1/16W
R101	1-216-830-11	METAL CHIP 5.6K 5%	1/16W
R102	1-216-864-11	METAL CHIP 0 5%	1/16W
R103	1-218-740-11	METAL CHIP 100K 0.50%	1/16W
R104	1-218-716-11	METAL CHIP 10K 0.50%	1/16W
R105	1-216-821-11	METAL CHIP 1K 5%	1/16W
R106	1-216-830-11	METAL CHIP 5.6K 5%	1/16W
R108	1-218-724-11	METAL CHIP 22K 0.50%	1/16W
R109	1-216-809-11	METAL CHIP 100 5%	1/16W
R110	1-216-834-11	METAL CHIP 12K 5%	1/16W
R111	1-216-821-11	METAL CHIP 1K 5%	1/16W
R113	1-218-736-11	METAL CHIP 68K 0.50%	1/16W
R115	1-218-716-11	METAL CHIP 10K 0.50%	1/16W
R116	1-218-716-11	METAL CHIP 10K 0.50%	1/16W
R117-119	1-216-864-11	METAL CHIP 0 5%	1/16W
R120	1-216-822-11	METAL CHIP 1.2K 5%	1/16W
R121	1-216-864-11	METAL CHIP 0 5%	1/16W
R122	1-218-672-11	METAL CHIP 150 0.50%	1/16W
R123	1-218-672-11	METAL CHIP 150 0.50%	1/16W
R127	1-216-804-11	METAL CHIP 39 5%	1/16W
R129	1-218-724-11	METAL CHIP 22K 0.50%	1/16W
R130	1-216-809-11	METAL CHIP 100 5%	1/16W

MAIN	TRANSFORMER
-------------	--------------------

Ref. No.	Part No.	Description	Remark		
R132	1-216-802-11	METAL GLAZE	27	5%	1/16W
R133	1-216-848-11	METAL CHIP	180K	5%	1/16W
R136	1-216-817-11	METAL CHIP	470	5%	1/16W
R137	1-218-295-11	METAL CHIP	5.6K	0.50%	1/16W
R138	1-218-716-11	METAL CHIP	10K	0.50%	1/16W
R140	1-216-864-11	METAL CHIP	0	5%	1/16W
R141	1-218-716-11	METAL CHIP	10K	0.50%	1/16W
R151	1-218-670-11	METAL CHIP	120	0.50%	1/16W
R152	1-216-821-11	METAL CHIP	1K	5%	1/16W
R153	1-218-484-11	METAL CHIP	750	0.50%	1/16W
R155	1-218-695-11	METAL CHIP	1.3K	0.50%	1/16W
R156	1-216-804-11	METAL CHIP	39	5%	1/16W
R157	1-218-716-11	METAL CHIP	10K	0.50%	1/16W
R158	1-216-821-11	METAL CHIP	1K	5%	1/16W
R159	1-216-821-11	METAL CHIP	1K	5%	1/16W
R160	1-218-700-11	METAL CHIP	2.2K	0.50%	1/16W
R162	1-218-716-11	METAL CHIP	10K	0.50%	1/16W
R164	1-216-821-11	METAL CHIP	1K	5%	1/16W
R173	1-216-699-11	METAL CHIP	100K	0.5%	1/10W
R174	1-216-833-11	METAL CHIP	10K	5%	1/16W
R177	1-216-833-11	METAL CHIP	10K	5%	1/16W
R178	1-218-732-11	METAL CHIP	47K	0.50%	1/16W
R179	1-218-732-11	METAL CHIP	47K	0.50%	1/16W
R180	1-216-809-11	METAL CHIP	100	5%	1/16W
R181	1-216-833-11	METAL CHIP	10K	5%	1/16W
R201	1-216-830-11	METAL CHIP	5.6K	5%	1/16W
R202	1-216-864-11	METAL CHIP	0	5%	1/16W
R203	1-218-740-11	METAL CHIP	100K	0.50%	1/16W
R204	1-218-716-11	METAL CHIP	10K	0.50%	1/16W
R205	1-216-821-11	METAL CHIP	1K	5%	1/16W
R206	1-216-830-11	METAL CHIP	5.6K	5%	1/16W
R208	1-218-724-11	METAL CHIP	22K	0.50%	1/16W
R209	1-216-809-11	METAL CHIP	100	5%	1/16W
R210	1-216-834-11	METAL CHIP	12K	5%	1/16W
R211	1-216-821-11	METAL CHIP	1K	5%	1/16W
R213	1-218-736-11	METAL CHIP	68K	0.50%	1/16W
R215	1-218-716-11	METAL CHIP	10K	0.50%	1/16W
R216	1-218-716-11	METAL CHIP	10K	0.50%	1/16W
R217-219	1-216-864-11	METAL CHIP	0	5%	1/16W
R220	1-216-822-11	METAL CHIP	1.2K	5%	1/16W
R221	1-216-864-11	METAL CHIP	0	5%	1/16W
R222	1-218-672-11	METAL CHIP	150	0.50%	1/16W
R223	1-218-672-11	METAL CHIP	150	0.50%	1/16W
R227	1-216-804-11	METAL CHIP	39	5%	1/16W
R229	1-218-724-11	METAL CHIP	22K	0.50%	1/16W
R230	1-216-809-11	METAL CHIP	100	5%	1/16W
R232	1-216-802-11	METAL GLAZE	27	5%	1/16W
R233	1-216-848-11	METAL CHIP	180K	5%	1/16W

Ref. No.	Part No.	Description	Remark		
R236	1-216-817-11	METAL CHIP	470	5%	1/16W
R237	1-218-295-11	METAL CHIP	5.6K	0.50%	1/16W
R238	1-218-716-11	METAL CHIP	10K	0.50%	1/16W
R240	1-216-864-11	METAL CHIP	0	5%	1/16W
R241	1-218-716-11	METAL CHIP	10K	0.50%	1/16W
R251	1-218-670-11	METAL CHIP	120	0.50%	1/16W
R252	1-216-821-11	METAL CHIP	1K	5%	1/16W
R253	1-218-484-11	METAL CHIP	750	0.50%	1/16W
R255	1-218-695-11	METAL CHIP	1.3K	0.50%	1/16W
R256	1-216-804-11	METAL CHIP	39	5%	1/16W
R257	1-218-716-11	METAL CHIP	10K	0.50%	1/16W
R258	1-216-821-11	METAL CHIP	1K	5%	1/16W
R259	1-216-821-11	METAL CHIP	1K	5%	1/16W
R260	1-218-700-11	METAL CHIP	2.2K	0.50%	1/16W
R262	1-218-716-11	METAL CHIP	10K	0.50%	1/16W
R264	1-216-821-11	METAL CHIP	1K	5%	1/16W
R273	1-216-699-11	METAL CHIP	100K	0.5%	1/10W
R274	1-216-833-11	METAL CHIP	10K	5%	1/16W
R277	1-216-833-11	METAL CHIP	10K	5%	1/16W
R278	1-218-732-11	METAL CHIP	47K	0.50%	1/16W
R279	1-218-732-11	METAL CHIP	47K	0.50%	1/16W
R280	1-216-809-11	METAL CHIP	100	5%	1/16W
R281	1-216-833-11	METAL CHIP	10K	5%	1/16W
R301	1-216-815-11	METAL CHIP	330	5%	1/16W
R304	1-216-841-11	METAL CHIP	47K	5%	1/16W
R305	1-216-845-11	METAL CHIP	100K	5%	1/16W
R306	1-216-845-11	METAL CHIP	100K	5%	1/16W
R307	1-216-821-11	METAL CHIP	1K	5%	1/16W
R308	1-216-821-11	METAL CHIP	1K	5%	1/16W
R309	1-218-732-11	METAL CHIP	47K	0.50%	1/16W
R310	1-218-732-11	METAL CHIP	47K	0.50%	1/16W
R312	1-216-834-11	METAL CHIP	12K	5%	1/16W
R313	1-216-825-11	METAL CHIP	2.2K	5%	1/16W
R314	1-216-833-11	METAL CHIP	10K	5%	1/16W
R315	1-216-825-11	METAL CHIP	2.2K	5%	1/16W
R316	1-216-825-11	METAL CHIP	2.2K	5%	1/16W
R317	1-216-845-11	METAL CHIP	100K	5%	1/16W
R318	1-216-825-11	METAL CHIP	2.2K	5%	1/16W
R319	1-216-825-11	METAL CHIP	2.2K	5%	1/16W
R320	1-216-851-11	METAL CHIP	330K	5%	1/16W
R321	1-216-833-11	METAL CHIP	10K	5%	1/16W
R322	1-216-833-11	METAL CHIP	10K	5%	1/16W
R324	1-216-845-11	METAL CHIP	100K	5%	1/16W
R327	1-164-156-11	CERAMIC CHIP	0.1uF		25V
R330	1-218-732-11	METAL CHIP	47K	0.50%	1/16W
R331	1-218-732-11	METAL CHIP	47K	0.50%	1/16W
R332	1-216-827-11	METAL CHIP	3.3K	5%	1/16W
R334	1-216-821-11	METAL CHIP	1K	5%	1/16W
R336	1-216-821-11	METAL CHIP	1K	5%	1/16W

MAIN

TRANSFORMER

Ref. No.	Part No.	Description	Remark
R337	1-216-001-00	METAL CHIP	10 5% 1/10W
R338	1-216-854-11	METAL CHIP	0 5% 1/16W
R342	1-216-834-11	METAL CHIP	12K 5% 1/16W
R343	1-216-848-11	METAL CHIP	180K 5% 1/16W
R344	1-216-821-11	METAL CHIP	1K 5% 1/16W
R351	1-216-833-11	METAL CHIP	10K 5% 1/16W
R352	1-216-854-11	METAL CHIP	560K 5% 1/16W
R354	1-216-833-11	METAL CHIP	10K 5% 1/16W
R355	1-216-854-11	METAL CHIP	560K 5% 1/16W
R356	1-216-821-11	METAL CHIP	1K 5% 1/16W
R358	1-216-841-11	METAL CHIP	47K 5% 1/16W
R359	1-216-857-11	METAL CHIP	1M 5% 1/16W
R360	1-216-821-11	METAL CHIP	1K 5% 1/16W
R361	1-216-833-11	METAL CHIP	10K 5% 1/16W
R365	1-216-001-00	METAL CHIP	10 5% 1/10W
R366	1-216-809-11	METAL CHIP	100 5% 1/16W
R371	1-216-821-11	METAL CHIP	1K 5% 1/16W
R372	1-216-854-11	METAL CHIP	560K 5% 1/16W
R373	1-216-833-11	METAL CHIP	10K 5% 1/16W
R374	1-216-827-11	METAL CHIP	3.3K 5% 1/16W
R375	1-216-857-11	METAL CHIP	1M 5% 1/16W
R376	1-216-841-11	METAL CHIP	47K 5% 1/16W
R377	1-216-821-11	METAL CHIP	1K 5% 1/16W
R378	1-216-809-11	METAL CHIP	100 5% 1/16W
R379	1-216-834-11	METAL CHIP	12K 5% 1/16W
R380	1-216-848-11	METAL CHIP	180K 5% 1/16W
R381	1-216-830-11	METAL CHIP	5.6K 5% 1/16W
R382	1-216-834-11	METAL CHIP	12K 5% 1/16W
R383	1-216-829-11	METAL CHIP	4.7K 5% 1/16W
R384	1-216-848-11	METAL CHIP	180K 5% 1/16W
R385	1-216-823-11	METAL CHIP	1.5K 5% 1/16W
R386	1-218-732-11	METAL CHIP	47K 0.50% 1/16W
R387	1-218-732-11	METAL CHIP	47K 0.50% 1/16W
R389	1-218-732-11	METAL CHIP	47K 0.50% 1/16W
R390	1-218-732-11	METAL CHIP	47K 0.50% 1/16W
R392	1-216-833-11	METAL CHIP	10K 5% 1/16W
R393	1-216-821-11	METAL CHIP	1K 5% 1/16W
R395	1-218-716-11	METAL CHIP	10K 0.50% 1/16W
R396	1-218-295-11	METAL CHIP	5.6K 0.50% 1/16W
R501	1-216-794-11	METAL CHIP	5.6 5% 1/16W
R502	1-216-828-11	METAL CHIP	3.9K 5% 1/16W
R503	1-216-813-11	METAL CHIP	220 5% 1/16W
R504	1-216-830-11	METAL CHIP	5.6K 5% 1/16W
R505	1-216-794-11	METAL CHIP	5.6 5% 1/16W
R506	1-216-794-11	METAL CHIP	5.6 5% 1/16W
R508	1-216-843-11	METAL CHIP	68K 5% 1/16W
R509	1-216-811-11	METAL CHIP	150 5% 1/16W
R510	1-216-843-11	METAL CHIP	68K 5% 1/16W
R511	1-216-840-11	METAL CHIP	39K 5% 1/16W

Ref. No.	Part No.	Description	Remark
R512-514			
	1-216-834-11	METAL CHIP	12K 5% 1/16W
R516	1-216-023-00	METAL CHIP	82 5% 1/10W
R517	1-216-813-11	METAL CHIP	220 5% 1/16W
R518	1-217-806-11	METAL GLAZE	1 5% 1/8W
R519	1-217-806-11	METAL GLAZE	1 5% 1/8W
R520	1-216-841-11	METAL CHIP	47K 5% 1/16W
R521	1-216-833-11	METAL CHIP	10K 5% 1/16W
R522	1-216-833-11	METAL CHIP	10K 5% 1/16W
R523	1-216-832-11	METAL CHIP	8.2K 5% 1/16W
R524	1-216-828-11	METAL CHIP	3.9K 5% 1/16W
R525	1-216-844-11	METAL CHIP	82K 5% 1/16W
R526	1-216-843-11	METAL CHIP	68K 5% 1/16W
R527	1-216-829-11	METAL CHIP	4.7K 5% 1/16W
R528	1-216-826-11	METAL CHIP	2.7K 5% 1/16W
R529	1-218-734-11	METAL CHIP	56K 0.50% 1/16W
R530	1-216-826-11	METAL CHIP	2.7K 5% 1/16W
R531	1-216-825-11	METAL CHIP	2.2K 5% 1/16W
R533	1-218-748-11	METAL CHIP	220K 0.50% 1/16W
R534	1-218-748-11	METAL CHIP	220K 0.50% 1/16W
R535	1-216-837-11	METAL CHIP	22K 5% 1/16W
R536	1-216-837-11	METAL CHIP	22K 5% 1/16W
R538	1-216-837-11	METAL CHIP	22K 5% 1/16W
R539	1-216-837-11	METAL CHIP	22K 5% 1/16W
R540-542			
	1-216-845-11	METAL CHIP	100K 5% 1/16W
R544	1-216-833-11	METAL CHIP	10K 5% 1/16W
R545	1-216-801-11	METAL CHIP	22 5% 1/16W
R546	1-216-833-11	METAL CHIP	10K 5% 1/16W
R547	1-216-829-11	METAL CHIP	4.7K 5% 1/16W
R548	1-216-829-11	METAL CHIP	4.7K 5% 1/16W
R549	1-216-833-11	METAL CHIP	10K 5% 1/16W
R550	1-216-174-00	METAL GLAZE	100 5% 1/8W
R551	1-216-839-11	METAL CHIP	33K 5% 1/16W
R552	1-216-834-11	METAL CHIP	12K 5% 1/16W
R553	1-218-676-11	METAL CHIP	220 0.50% 1/16W
R554	1-216-839-11	METAL CHIP	33K 5% 1/16W
R555	1-216-811-11	METAL CHIP	150 5% 1/16W
R556	1-216-818-11	METAL CHIP	560 5% 1/16W
R557	1-216-818-11	METAL CHIP	560 5% 1/16W
R558	1-218-676-11	METAL CHIP	220 0.50% 1/16W
R559	1-218-740-11	METAL CHIP	100K 0.50% 1/16W
R560	1-216-817-11	METAL CHIP	470 5% 1/16W
R561	1-216-817-11	METAL CHIP	470 5% 1/16W
R562	1-216-821-11	METAL CHIP	1K 5% 1/16W
R563	1-216-845-11	METAL CHIP	100K 5% 1/16W
R564	1-216-864-11	METAL CHIP	0 5% 1/16W
R565	1-216-843-11	METAL CHIP	68K 5% 1/16W
R566	1-216-817-11	METAL CHIP	470 5% 1/16W

Ref. No.	Part No.	Description	Remark		
R567	1-216-837-11	METAL CHIP	22K	5%	1/16W
R568	1-216-809-11	METAL CHIP	100	5%	1/16W
R569	1-216-841-11	METAL CHIP	47K	5%	1/16W
R570-572					
	1-216-809-11	METAL CHIP	100	5%	1/16W
R573	1-216-841-11	METAL CHIP	47K	5%	1/16W
R574	1-216-817-11	METAL CHIP	470	5%	1/16W
R575	1-216-845-11	METAL CHIP	100K	5%	1/16W
R576	1-216-833-11	METAL CHIP	10K	5%	1/16W
R577	1-216-845-11	METAL CHIP	100K	5%	1/16W
R578	1-216-842-11	METAL CHIP	56K	5%	1/16W
R579	1-216-838-11	METAL CHIP	27K	5%	1/16W
R580	1-216-838-11	METAL CHIP	27K	5%	1/16W
R581	1-216-835-11	METAL CHIP	15K	5%	1/16W
R582	1-216-794-11	METAL CHIP	5.6	5%	1/16W
R583	1-216-825-11	METAL CHIP	2.2K	5%	1/16W
R584	1-216-825-11	METAL CHIP	2.2K	5%	1/16W
R585	1-216-834-11	METAL CHIP	12K	5%	1/16W
R586	1-218-732-11	METAL CHIP	47K	0.50%	1/16W
R587	1-216-829-11	METAL CHIP	4.7K	5%	1/16W
R588	1-216-819-11	METAL CHIP	680	5%	1/16W
R589	1-216-849-11	METAL CHIP	220K	5%	1/16W
R590	1-216-849-11	METAL CHIP	220K	5%	1/16W
R591	1-162-968-11	CERAMIC CHIP	0.0047uF	10%	50V
R592	1-216-843-11	METAL CHIP	68K	5%	1/16W
R593	1-216-843-11	METAL CHIP	68K	5%	1/16W
R596-598					
	1-216-845-11	METAL CHIP	100K	5%	1/16W
R599	1-216-854-11	METAL CHIP	560K	5%	1/16W
R600	1-216-829-11	METAL CHIP	4.7K	5%	1/16W
R601	1-216-833-11	METAL CHIP	10K	5%	1/16W
R602	1-216-812-11	METAL CHIP	180	5%	1/16W
R603-607					
	1-216-864-11	METAL CHIP	0	5%	1/16W
R608	1-216-816-11	METAL CHIP	390	5%	1/16W
R609	1-216-849-11	METAL CHIP	220K	5%	1/16W
R610	1-216-837-11	METAL CHIP	22K	5%	1/16W
R611	1-216-838-11	METAL CHIP	27K	5%	1/16W
R614	1-216-841-11	METAL CHIP	47K	5%	1/16W
< VARIABLE RESISTOR >					
RV301	1-223-361-11	RES. VAR. CARBON 20K/20K (REC LEVEL)			
RV501	1-238-667-21	RES. ADJ. CERMET 100K			
< SWITCH >					
S301	1-571-277-11	SWITCH, SLIDE (MIC SENS)			
S302	1-571-506-11	SWITCH, SLIDE (REC MODF)			
S501	1-571-275-31	SWITCH, SLIDE (SP/LP)			

Ref. No.	Part No.	Description	Remark		
< VIBRATOR >					
X501	1-579-924-21	VIBRATOR, CRYSTAL (CHIP TYPE) (9.408MHz)			
X502	1-579-924-21	VIBRATOR, CRYSTAL (CHIP TYPE) (9.408MHz)			
X503	1-579-923-21	VIBRATOR, CRYSTAL (CHIP TYPE) (22.5792MHz)			
X504	1-579-922-21	VIBRATOR, CRYSTAL (CHIP TYPE) (24.576MHz)			

*	1-648-989-11	STOP BOARD			

< CAPACITOR >					
C3001	1-135-148-21	TANTALUM CHIP	1.5uF	20%	10V
< TRANSISTOR >					
Q3001	8-729-420-50	TRANSISTOR	UN5215		
< RESISTOR >					
R3001	1-216-837-11	METAL CHIP	22K	5%	1/16W
R3002	1-216-841-11	METAL CHIP	47K	5%	1/16W

MISCELLANEOUS					

6	1-467-043-11	PC BOARD UNIT, SYSTEM CONTROL			
25	1-467-044-11	SWITCH UNIT (BLOCK TYPE)			
154	X-4943-984-1	DRUM ASSY (INCLUDING RF UNIT)			
180	8-835-495-01	MOTOR, DC SCR-0201A			
D1001	8-719-888-42	LED	GL453S		
M1001	1-698-104-11	MOTOR, DC (WITH GEAR)			
PM1001	1-454-602-11	SOLENOID, PLUNGER			
Q1001	8-729-925-30	END SENSOR	PT4810F		
Q1002	8-729-925-30	END SENSOR	PT4810F		
S1001	1-571-878-11	SWITCH, PUSH (2 KEY) (CASSETTE DET/REC PROOF)			
S1002	1-572-288-11	SWITCH, PUSH (AC POWER) (1 KEY) (CASSETTE CONTROL LOCK)			

Ref. No.	Part No.	Description	Remark
----------	----------	-------------	--------

ACCESSORIES & PACKING MATERIALS

- | | | | |
|---|--------------|---|--|
| △ | 1 466-777-11 | ADAPTOR, AC (AC-F60L) (AEP) | |
| | 1-467-063-11 | REMOTE COMMANDER (RMT-D7) (JE) | |
| △ | 1-467-064-11 | ADAPTOR, AC (AC-E60AM) (JE) | |
| △ | 1-569-007-11 | ADAPTER, CONVERSION 2P (JE) | |
| | 1-590-161-11 | CORD, CONNECTION (JE) | |
| | 1-590-264-11 | CABLE, OPTICAL DIGITAL (AEP, JE) | |
| * | 3-387-733-01 | INDIVIDUAL CARTON (JE) | |
| | 3-388-826-01 | CASE, CARRYING | |
| | 3-756-633-01 | MANUAL, INSTRUCTION (JAPANESE) (JE) | |
| | 3-756-633-11 | MANUAL, INSTRUCTION (ENGLISH, FRENCH, SPANISH) (Canadian, AEP, G, JF) | |
| | 3-756-633-21 | MANUAL, INSTRUCTION (ENGLISH) (US) | |
| | 3-756-633-41 | MANUAL, INSTRUCTION (GERMAN, DUTCH, ITALIAN) (AEP, G) | |
| | 3-756-633-51 | MANUAL, INSTRUCTION (PORTUGUESE, SWEDISH, KOREAN) (AEP, G, JE) | |
| * | 4-960-131-01 | INDIVIDUAL CARTON (US, Canadian) | |
| * | 4-960-132-01 | INDIVIDUAL CARTON (G) | |
| * | 4-960-134-01 | INDIVIDUAL CARTON (AEP) | |

HARDWARE LIST

- | | | |
|----|--------------|-----------------------------|
| #1 | 7-627-451-57 | SCREW, PRECISION -K 1.4X4 |
| #2 | 7-627-551-47 | SCREW, PRECISION -P 1.4X1.4 |

The components identified by mark △ or dotted line with mark △ are critical for safety. Replace only with part number specified.	Les composants identifiés par une marque △ sont critiques pour la sécurité. Ne les remplacer que par une pièce portant le numéro spécifié.
--	--

TCD-D7/D7K

SONY[®] SERVICE MANUAL

US Model
Canadian Model
AEP Model
TCD-D7
Tourist Model
TCD-D7K

SUPPLEMENT-1

File This Supplement with Service Manual.

- | |
|---|
| <ul style="list-style-type: none">1-1. ADJUSTMENTS1-2. MECHANICAL ADJUSTMENTS1-3. ELECTRICAL ADJUSTMENTS2. BLOCK DIAGRAM |
|---|

SECTION 1-1 ADJUSTMENTS

NOTES FOR ADJUSTMENT

1. The adjustments should be performed in sequence that they are described.
2. Use the following test tapes :
 TY-7111 (8-909-812-00) for level
 TY-7915 (8-913-932-00) for tape path and SWP
 TY-30B (8-892-358-00) blank tape
 Use the following torque meter :
 TW-7131 (8-909-708-71) for FWD and back tension
3. Set the switch and control to the following positions :
 LP/SP (S501)SP
 HOLD (S704)Released side (in the opposite of -> position)
4. Apply 6.0Vdc from the DC IN jack as power supply.
5. For cleaning of the drum, use the chamois leather (2-034-697-00) or four folds of cloth (knitted fabric) wetted with a little amount of alcohol and lightly apply it onto the drum. Then rotate the drum counterclockwise (two to three turns) to clean it.

TEST MODE

1. Enter the Test Mode before performing adjustment.
2. With the power ON, simultaneously press the STOP key, COUNTER key and OPEN button on the set to enter Test Mode. Turn the power OFF to release the Test Mode.
3. When the Test Mode is set, the LCD back light will be lit and the following initial display will appear. Also, the mechanism will be put in the loading state and the segments of the Selected Test Mode Code on the LCD display will be flashing (continuously).

LCD Initial Display

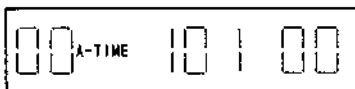

Note : During the Test Mode, each key on the set is available to operate it. In this case, malfunction may occur, but it will be released by pressing ■ key on the set. Also, this malfunction will not cause any damage to tape.

4. Types of Test Modes

Test Mode Code	Contents
01	Normal operation mode
02	Error rate measurement mode
30	End sensor check mode
40	Mechanism single operation mode
41	Constant voltage drive mode
42	Tape path adjustment mode

5. Setting of Test Mode Code (remote commander MDR-ED7 is required.)

• Test Mode Display

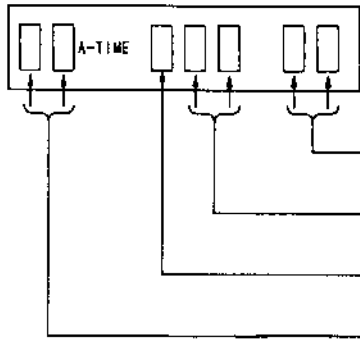

Note: During the Test Mode, the display is switched by pressing the COUNTER key on the set. Select the Absolute Time display (" A-TIME " illuminated) to check the current Test Mode.

- Set Test Mode CodeSegments illuminated.
- Selected Test Mode CodeSegments flashing.
- Capstan speed codeCapstan speed displayed in test codes 40 and 42.
- Error codeSegments displayed in case of emergency in test mode.

1) Each time ►► key on remote commander is pressed, the segment value of the Selected Test Mode Code changes as follows :

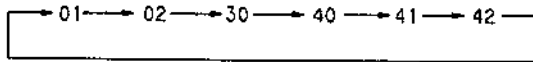

2) Each time ◀◀ key on remote commander is pressed, the segment value of the Selected Test Mode Code changes is reverse order from the above order.

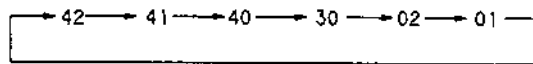

3) Set the Test Mode Code by pressing ► key on remote commander. (After this setting is completed, the Selected Test Mode Code is flashing.)

6. Description of Test Mode Codes

01.....Normal operation mode

This mode produces the same state as the state of the set where the Test Mode is not entered. However, malfunction may occur. So when checking the set in normal operation, do without entering the Test Mode.

02.....Error rate measurement mode

An error rate counter is needed to measure the error rate. Therefore, this mode is not used for servicing.

30.....End sensor check mode

This mode is not available in this adjustment.

40.....Mechanism single operation mode

This mode is available whether tape is present or not.

Without tape, tape end and reel error detections are not performed but holder lock detection is performed.

With FF/REW and $\times 25$ FWD/ $\times 25$ REV selected, constant voltage drive is activated without tape while servo is activated with tape.

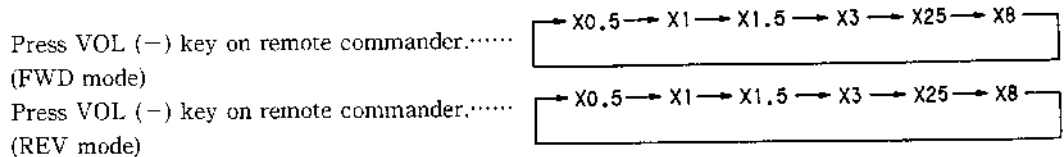

Capstan Speed Code Display	Capstan Speed	Drum Speed
1	$\times 0.5$ FWD	1000rpm
2	$\times 1$ FWD	2000rpm
3	$\times 1.5$ FWD	2000rpm
4	$\times 3$ FWD	2000rpm
5	$\times 25$ FWD	2000rpm
6	$\times 8$ FWD	2000rpm
-1	$\times 0.5$ REV	1000rpm
-2	$\times 1$ REV	2000rpm
-3	$\times 1.5$ REV	2000rpm
-4	$\times 3$ REV	2000rpm
5	$\times 25$ REV	2000rpm
-6	$\times 8$ REV	2000rpm

Note: In this mode, when tape is run with \blacktriangleright key on the set, even if the capstan speed code display is 1, the capstan speed will be set to $\times 1$ FWD. In this case, use VOL key on remote commander to change the speed, then press \blacktriangleright key on the remote commander.

41.....Constant voltage drive mode

In this mode, pressing \blacktriangleright key will cause the drum and the capstan to be driven at a constant voltage.

42.....Tape path adjustment mode

This mode displays the capstan speed and it is effective only when tape is mounted.

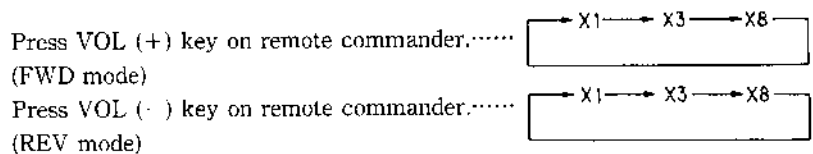

Capstan Speed Code Display	Capstan Speed	Drum Speed
1	$\times 1$ FWD	2000rpm
2	$\times 3$ FWD	2000rpm
3	$\times 8$ FWD	2000rpm
-1	$\times 1$ REV	2000rpm
-2	$\times 3$ REV	2000rpm
-3	$\times 8$ REV	2000rpm

7. Error Code List

Code No.	Block	Contents
00		No error (no emergency)
01-09	Control motor (encoder)	Unable to detect the position* ¹
10	Mechanism deck	Loading not completed
11		Unloading not completed
12		No eject
13		End sensor fault (T side)* ²
14		End sensor fault (S side)* ²
15		DEW detected* ²
20	Drum	Drum motor won't rotate
21		Drum servo not locked* ²
30	Capstan	Capstan motor won't rotate
31		Speed not locked
40	Reel	T reel FG not detected
41		S reel FG not detected
42		Measure abnormally ended

* 1 If the position of the rotary encoder is not detected, the position number for that position is preceded with 0 and this value is displayed as the error code. (See below)

EJECT : 01 Load : 04 FF : 07
 Unload : 02 REV : 05 STOP : 08
 CASIN : 03 FWD : 06 REW : 09

If an emergency occurs during each test mode, the error code will be displayed.

* 2 Displayed only during the Test Mode.

LOCATIONS OF PARTS ASSOCIATED WITH ADJUSTMENTS
—MECHANISM—

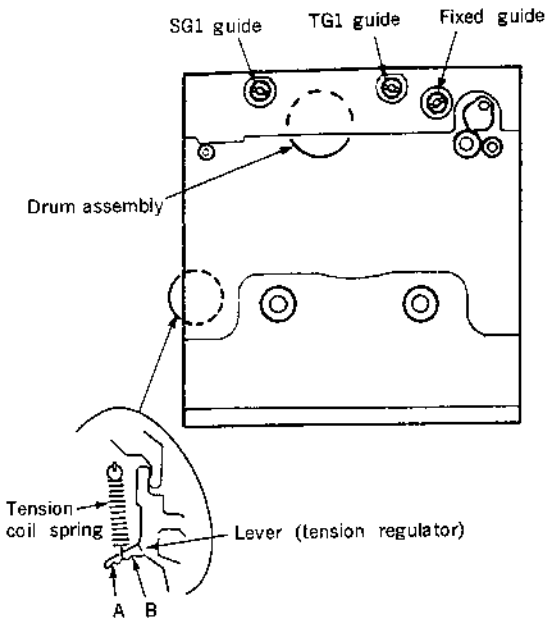

—MAIN BOARD—

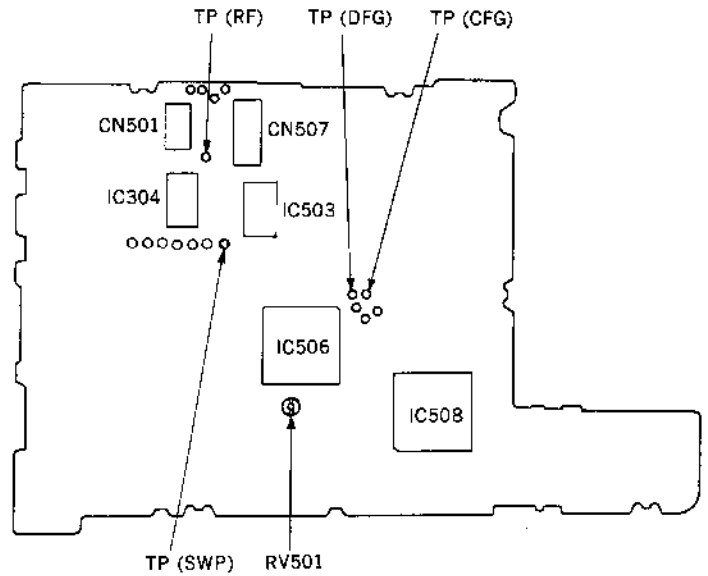

SECTION 1-2
MECHANICAL ADJUSTMENTS

These adjustment should be always performed when the drum was replaced.

TAPE PATH ADJUSTMENT

※ Only when checking the tape path, perform Items 6 to 9.

1. Enter the Test Mode, mount test TY-7915, and set tape near the center.
2. Set test mode code 42 and press VOL (+) key on remote commander. (×1FWD)
3. Lower SG1 guide (clockwise) and dislodge tape (Fig-1).
4. Lower TG1 guide (clockwise) and dislodge tape (Fig-2). Then, turn TG1 guide counterclockwise and adjust so that the right edge of the RF waveform (Fig-3) is at right angle.
5. Turn SG1 guide counterclockwise and adjust so that the left edge of the RF waveform (Fig-4) is at right angle.

—RF WAVEFORM—

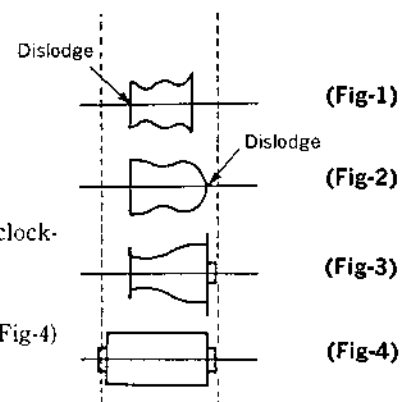

At this time, the lower flange of fixed guide should not be in contact with tape. Also, tape should run along the upper flanges of SG1 and TG1 guides.

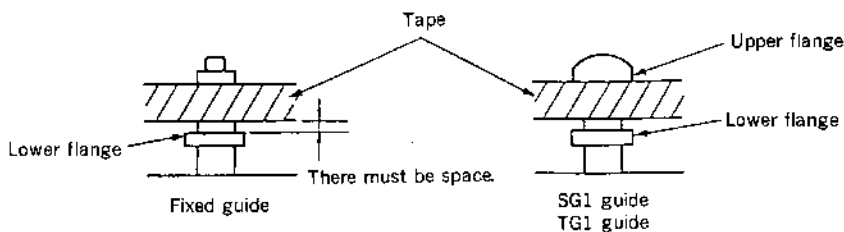

6. Check the RF waveform and fine adjust SG1 and TG1 guides.

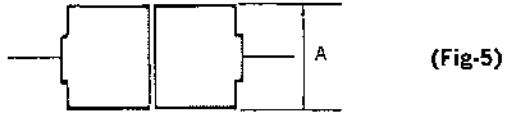

(Fig-5)

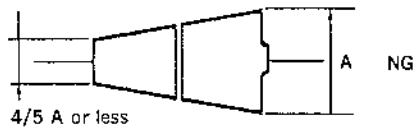

(Fig-6)

⇒ Fine adjust SG1 guide so as to obtain the waveform as shown in Fig-5.

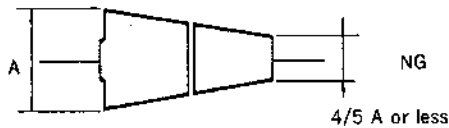

(Fig-7)

⇒ Fine adjust TG1 guide so as to obtain the waveform as shown in Fig-5.

Note: SG1 guide and TG1 guide should not be adjusted alternately. After one guide has been adjusted, the other guide should be adjusted.

- 1) Press STOP button, then press OPEN button to take out tape once.
- 2) Mount tape again and press VOL (+) key on remote commander to select ×1FWD.
- 3) Check the peak value and width of variation of the RF waveform.

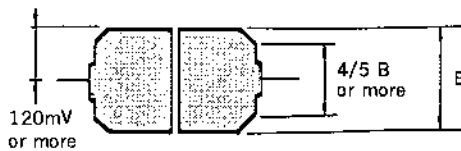

- 4) If the RF waveform does not satisfy the check values, repeat Items 6 to 7.
8. Press VOL (+) or VOL (-) key on remote commander to select ×1FWD or ×1REV.
Adjust the fixed guide so that the lower flange of the guide is positioned along tape. (No tape curl should be present.)

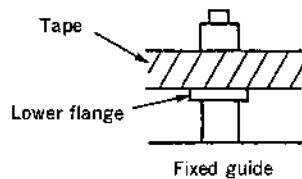

9. After performing ×8FWD, ×8REV, ×3FWD, and ×3REV operations, confirm that the RF waveform is state.

TORQUE CHECK

Preparation :

Remove the cassette lid from the cassette holder.

(×1FWD)

1. Set the Test Mode.
2. Set test mode code 40.
3. Mount torque meter TW-7131.
4. Press VOL (+) key on remote commander to select ×1FWD mode.
5. Check the torque meter.

FWD take-up torque 4.5—7.0g•cm
(0.063—0.097oz•inch)

FWD back tension 3.0—5.5g•cm
(0.042—0.076oz•inch)

6. If the back tension check value is not satisfied, place the tension coil spring set to the lever (tension regulator) to position either A or B. Check the back tension again.

(×1REV)

1. Perform the above items 1 to 3.
2. Press VOL (-) key on remote commander to select ×1REV mode.
3. Check the torque meter.

REV take-up torque 5.5—11.0g•cm
(0.077—0.152oz•inch)

REV back tension 6.0—12.0g•cm
(0.084—0.166oz•inch)

SPEED CHECK

(Capstan FG)

1. Connect frequency counter to TP CFG.
2. Set the Test Mode.
3. Set test mode code 40.
4. Mount test tape TY-30B.
5. Press VOL (+) key on remote commander and read the frequency in ×0.5FWD, ×1FWD, ×1.5FWD, ×3FWD, and ×8FWD modes.

Mode	Frequency
×0.5FWD	296Hz±5Hz
×1FWD	592Hz±5Hz
×1.5FWD	888Hz±3Hz
×3FWD	1776Hz±3Hz
×8FWD	4736Hz±5Hz

(Drum FG)

1. Connect frequency counter to TP DFG.
2. Perform the above Items 2 to 4.
3. Press VOL (-) key on remote commander and check the frequency in ×0.5FWD and ×1FWD.

Mode	Frequency
×0.5FWD	400Hz±1Hz
×1FWD	800Hz±1Hz

SECTION 1-3 ELECTRICAL ADJUSTMENTS

These adjustment should be always performed when the drum was replaced.

SWP (SWITCHING PULSE) ADJUSTMENT

Preparation : Oscilloscope CH-1 : AC 100mV/DIV
CH-2 : DC 2V/DIV
TRIG : CH-2

1. Connect CH-1 of oscilloscope to TP RF and CH-2 to TP SWP.
2. Set the Test Mode.
3. Set test mode code 42.
4. Mount test tape TY-7915.
5. Press VOL (+) key on remote commander to select $\times 1$ FWD.
6. Use RV501 to adjust the period (T) between SWP waveform and RF waveform.

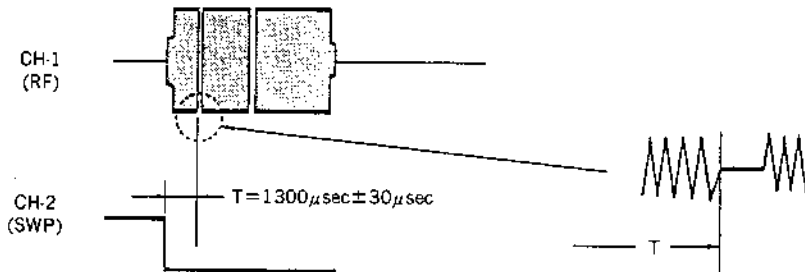

SECTION 2
BLOCK DIAGRAM

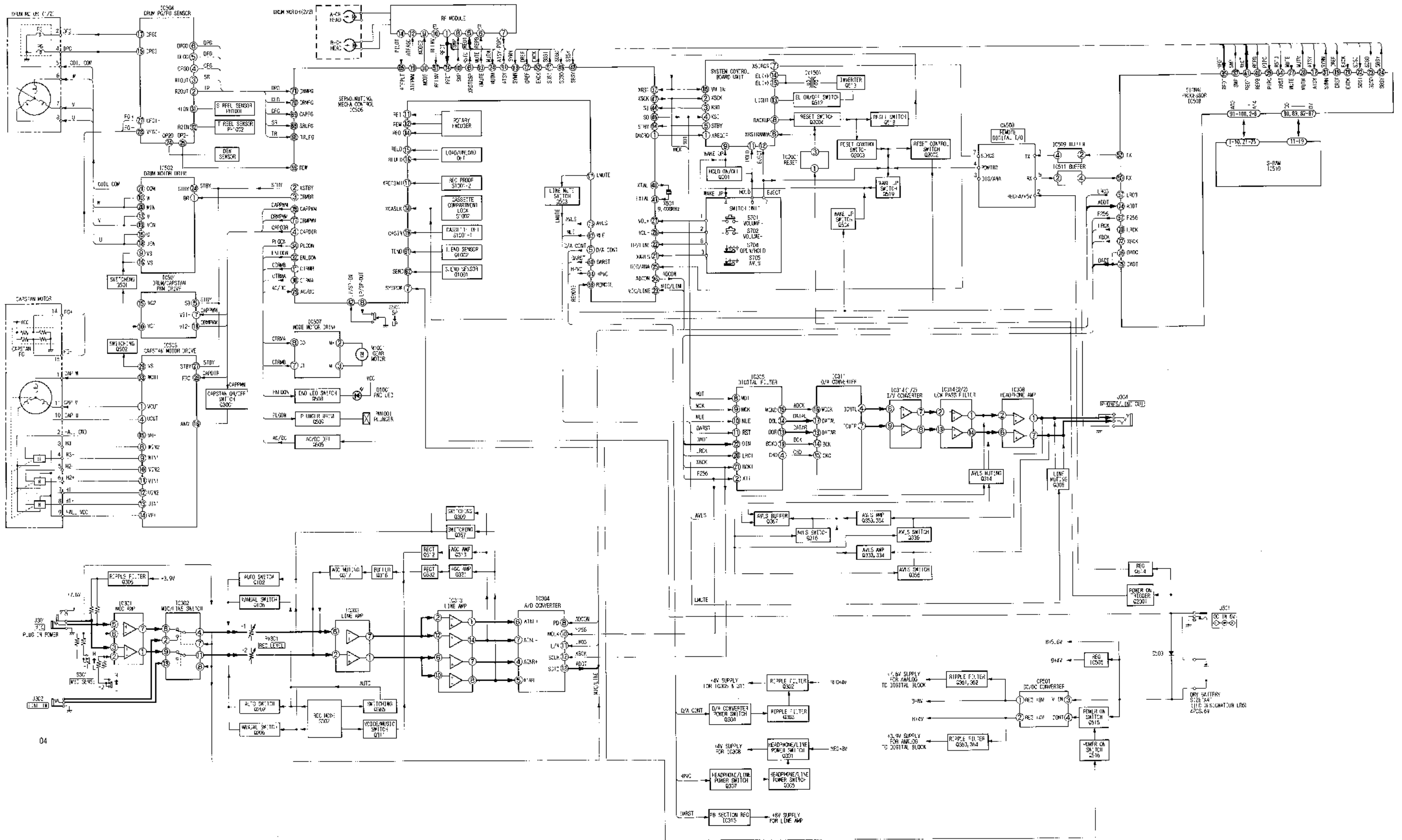

04

TCD-D7/D7K

SONY[®] SERVICE MANUAL

US Model
Canadian Model
AEP Model
TCD-D7
Tourist Model
TCD-D7K

SUPPLEMENT-2

File this supplement with the Service Manual.

We inform the user that according to change of the suffix of the printed wiring board, the printed wiring board and schematic diagram have been changed.

● Semiconductor Location

Ref. No.	Location	Ref. No.	Location
D102	C-3	Q202	F-26
D103	E-2	Q206	F-26
D104	E-26	Q301	G-4
D202	C-3	Q302	E-24
D203	F-26	Q303	F-24
D204	E-26	Q304	F-24
D301	C-27	Q305	G-5
D303	F-5	Q306	J-2
D331	F-25	Q307	G-5
D332	C-24	Q308	C-2
D340	F-24	Q309	G-4
D341	C-25	Q311	F-3
D501	H-20	Q312	F-24
D502	H-19	Q313	G-4
D503	I-19	Q314	C-4
D505	D-5	Q316	C-24
D506	D-10	Q317	F-3
D507	D-9	Q318	F-3
D508	D-9	Q331	F-25
D509	C-9	Q332	F-25
D510	C-9	Q333	C-25
D511	E-10	Q334	C-24
D512	D-8	Q353	C-24
D515	D-7	Q354	C-25
D516	D-7	Q355	D-25
D517	D-6	Q356	D-25
D518	C-7	Q357	F-25
D1001	H-13	Q361	F-25
		Q362	E-24
IC301	H-26	Q363	J-3
IC302	E-27	Q364	I-3
IC303	H-25	Q365	F-2
IC304	H-24	Q366	F-2
IC305	C-22	Q367	C-5
IC308	D-26	Q368	F-4
IC311	C-23	Q501	H-20
IC313	H-4	Q502	H-19
IC314	D-24	Q503	F-7
IC315	E-25	Q504	D-8
IC501	G-19	Q505	D-7
IC502	G-7	Q508	J-6
IC503	H-23	Q509	I-6
IC504	G-8	Q512	C-16
IC505	F-8	Q513	A-19
IC506	E-22	Q514	F-9
IC507	H-21	Q515	D-17
IC508	D-20	Q516	D-18
IC509	E-19	Q517	I-23
IC510	D-8	Q518	I-23
IC511	E-9	Q519	C-8
IC2001	H-22	Q1001	I-11
		Q1002	I-14
Q102	E-27	Q2001	G-22
Q106	F-26	Q3001	G-22

Note:
 ● : parts extracted from the conductor side.
 ○ : parts mounted on the conductor side.
 ■ : Pattern on the side which is seen.
 □ : Pattern on the rear side.

PRINTED WIRING BOARDS

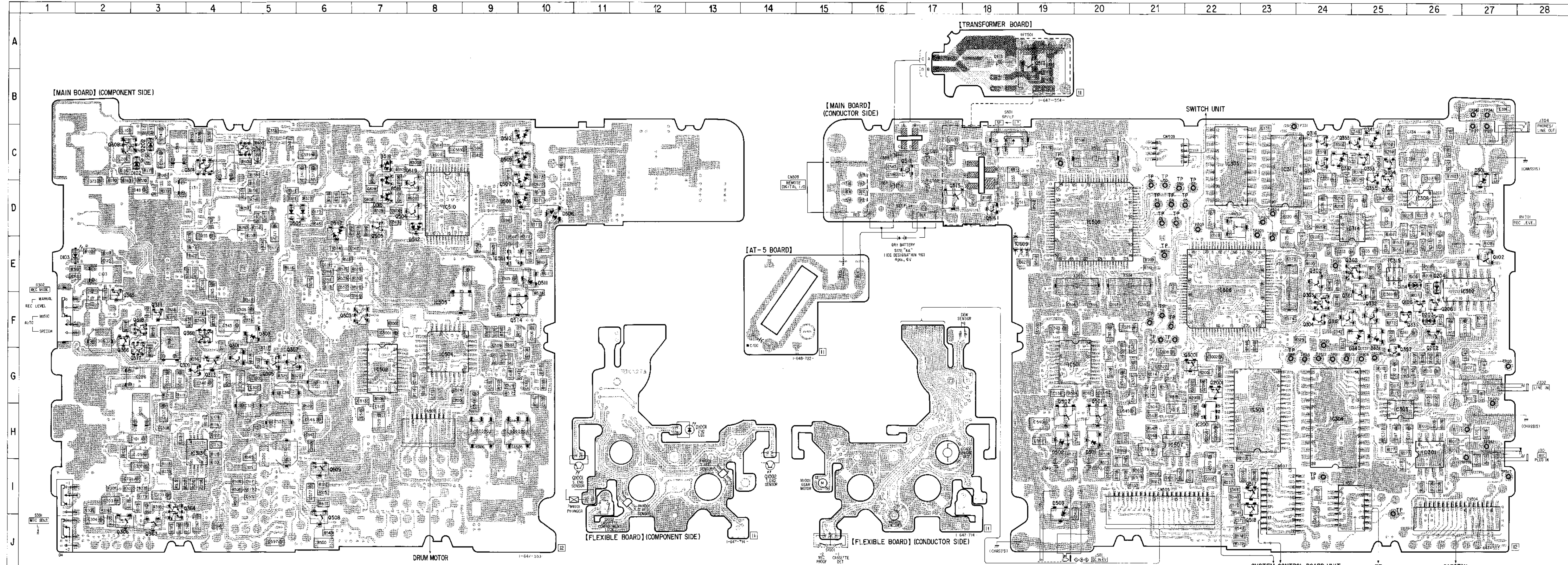

SCHEMATIC DIAGRAM—ANALOG SECTION—

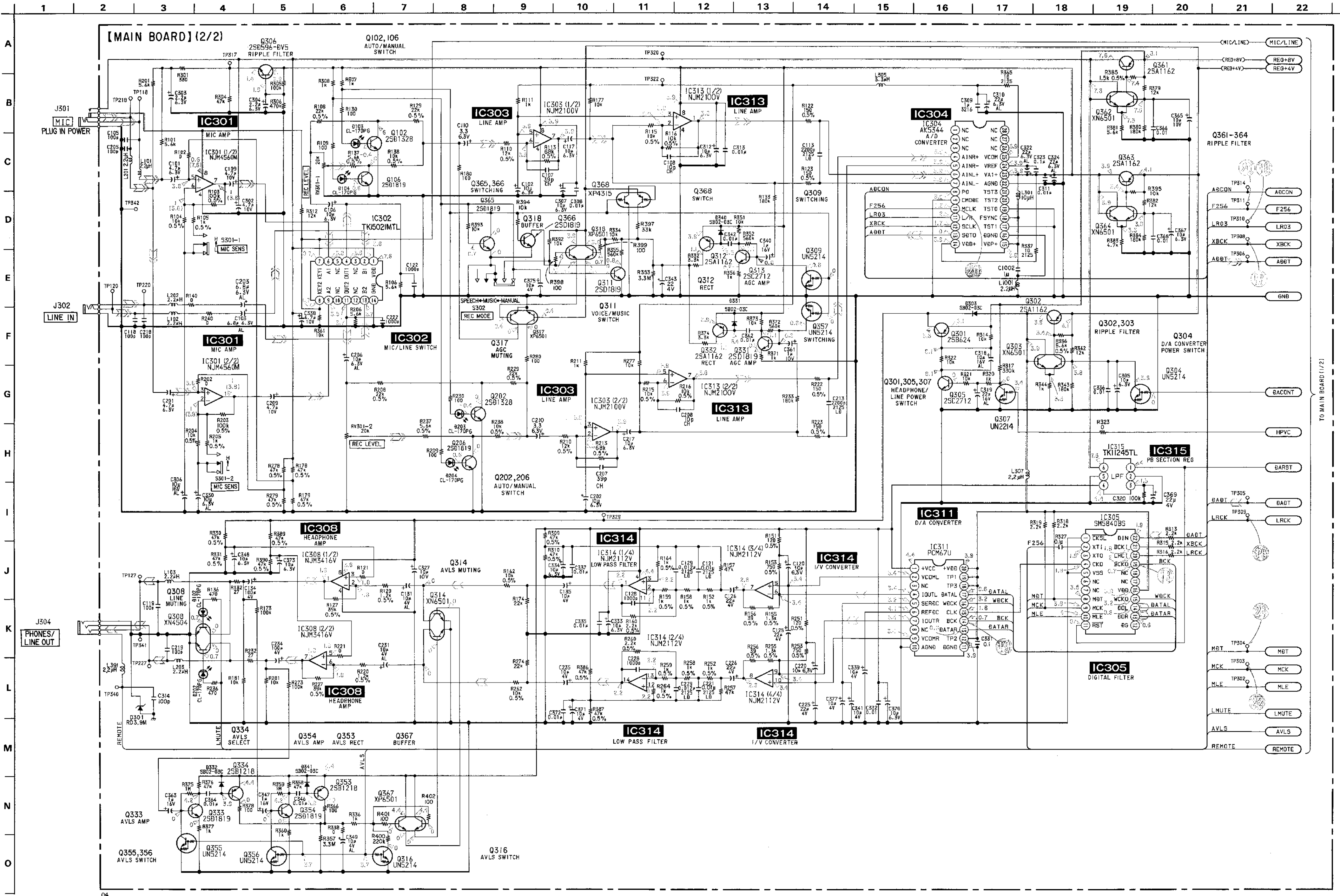

Note:

- All capacitors are in μF unless otherwise noted. $\text{pF} = \mu\text{F} \times 50\text{W}$ or less are not indicated except for electrolytics and tantalums.
- All resistors are in Ω and 1/4 W or less unless otherwise specified.
- % : indicates tolerance.

○ : LINE
 □ : POWER VOLTAGE IS DC 5V AND FED WITH REGULATED DC POWER SUPPLY FROM BATTERY TERMINAL.
 ○ : VOLTAGE AND WAVEFORMS ARE CO WITH RESPECT TO GROUND UNDER NO-SIGNAL CONDITIONS.
 ○ : no merit: PLAY
 ○ : REC
 ○ : Voltages are taken with a 10M Ω (input impedance 10k Ω). Voltage variations may be noted due to normal production tolerances.
 ○ : Waveforms are taken with an oscilloscope. Voltage variations may be noted due to normal production tolerances.
 ○ : Circled numbers refer to waveforms.
 ○ : Signal path.
 ○ : PB
 ○ : REC

SCHEMATIC DIAGRAM—MAIN SECTION—

- All capacitors are in μF unless otherwise noted. μF : μF 50WV or less are not indicated except for electrolytics and tantalums.
- All resistors are in Ω and 1/4 W or less unless otherwise specified.
- % : indicates tolerance.

- : 24-line
- Power voltage is dc 5V and led with regulated dc power supply from battery terminal.
- Voltage and waveforms are dc with respect to ground under no-signal conditions.
- no mark: PLAY
- >: REC

- Voltages are taken with a 10k Ω input impedance 10M Ω .
- Voltage variations may be noted due to normal production tolerances.
- Waveforms are taken with a scope.
- Voltage variations may be noted due to normal production tolerances.
- Circuit numbers refer to waveforms.

- Signal path.
- PD
- REC

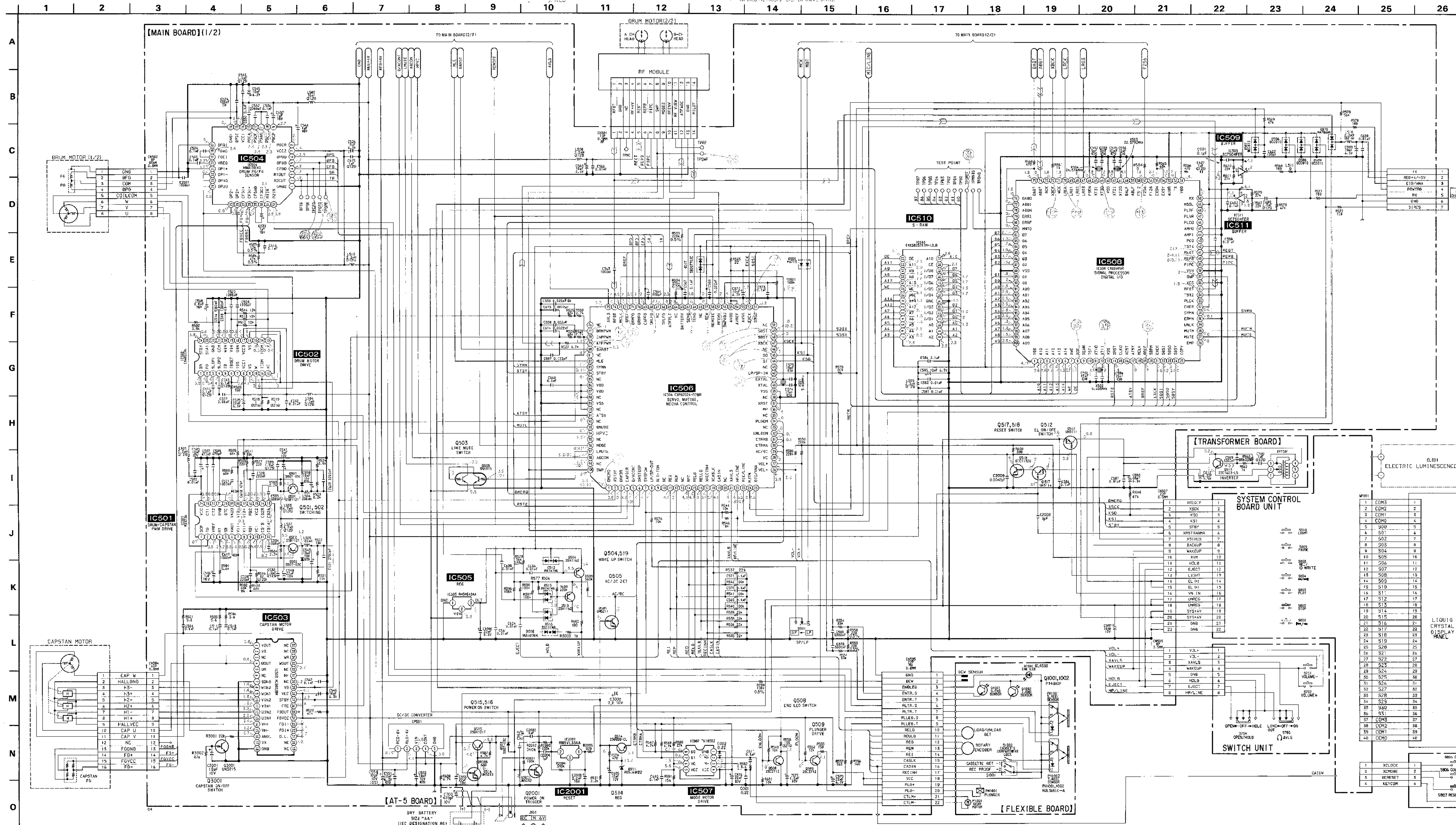

W01	1	2	3	4	5	6	7	8	9	10	11	12	13	14	15	16	17	18	19	20	21	22	23	24	25	26	
COMS	1	2	3	4	5	6	7	8	9	10	11	12	13	14	15	16	17	18	19	20	21	22	23	24	25	26	
COM1	2	3	4	5	6	7	8	9	10	11	12	13	14	15	16	17	18	19	20	21	22	23	24	25	26		
COM2	3	4	5	6	7	8	9	10	11	12	13	14	15	16	17	18	19	20	21	22	23	24	25	26			
COM3	4	5	6	7	8	9	10	11	12	13	14	15	16	17	18	19	20	21	22	23	24	25	26				
COM4	5	6	7	8	9	10	11	12	13	14	15	16	17	18	19	20	21	22	23	24	25	26					
COM5	6	7	8	9	10	11	12	13	14	15	16	17	18	19	20	21	22	23	24	25	26						
COM6	7	8	9	10	11	12	13	14	15	16	17	18	19	20	21	22	23	24	25	26							
COM7	8	9	10	11	12	13	14	15	16	17	18	19	20	21	22	23	24	25	26								
COM8	9	10	11	12	13	14	15	16	17	18	19	20	21	22	23	24	25	26									
COM9	10	11	12	13	14	15	16	17	18	19	20	21	22	23	24	25	26										
COM10	11	12	13	14	15	16	17	18	19	20	21	22	23	24	25	26											
COM11	12	13	14	15	16	17	18	19	20	21	22	23	24	25	26												
COM12	13	14	15	16	17	18	19	20	21	22	23	24	25	26													
COM13	14	15	16	17	18	19	20	21	22	23	24	25	26														
COM14	15	16	17	18	19	20	21	22	23	24	25	26															
COM15	16	17	18	19	20	21	22	23	24	25	26																
COM16	17	18	19	20	21	22	23	24	25	26																	
COM17	18	19	20	21	22	23	24	25	26																		
COM18	19	20	21	22	23	24	25	26																			
COM19	20	21	22	23	24	25	26																				
COM20	21	22	23	24	25	26																					
COM21	22	23	24	25	26																						
COM22	23	24	25	26																							
COM23	24	25	26																								
COM24	25	26																									
COM25	26																										
COM26																											

W01	1	2	3	4
XELCK	1	2	3	4
XELDR	1	2	3	4
XELSET	1	2	3	4
KEYCOM	1	2	3	4

ELECTRICAL PARTS LIST

NOTE:

- Due to standardization, replacements in the parts list may be different from the parts specified in the diagrams or the components used on the set.
- -XX and -X mean standardized parts, so they may have some difference from the original one.
- RESISTORS
All resistors are in ohms.
METAL: Metal-film resistor.
METAL OXIDE: Metal oxide-film resistor.
F: nonflammable

- Items marked "*" are not stocked since they are seldom required for routine service. Some delay should be anticipated when ordering these items.
- SEMICONDUCTORS
In each case, u: μ , for example:
uA.: μ A., uPA.: μ PA.,
uPB.: μ PB., uPC.: μ PC., uPD.: μ PD.
- CAPACITORS
uF: μ F
- COILS
uH: μ H

When indicating parts by reference number, please include the board.

Ref. No.	Part No.	Description	Remark	Ref. No.	Part No.	Description	Remark
*	1-648-722-11	AT-5 BOARD *****		C201	1-135-181-21	TANTALUM CHIP 4.7uF	20% 6.3V
		< CAPACITOR >		C202	1-135-259-11	TANTAL. CHIP 10uF	20% 6.3V
C700	1-104-964-21	ELECT 470uF	20% 10V	C203	1-128-019-11	ELECT CHIP 6.8uF	6.3V
*****				C205	1-162-953-11	CERAMIC CHIP 100PF	5% 50V
	A-3016-354-A	MAIN BOARD, COMPLETE (INCLUDING TRANSFORMER BOARD) *****		C206	1-128-020-11	ELECT CHIP 10uF	6.3V
	3-387-477-01	TERMINAL (MAIN), BATTERY		C207	1-162-922-11	CERAMIC CHIP 39PF	5% 50V
	3-708-377-01	SLIDER, SURF LOCK (16P)		C208	1-162-915-11	CERAMIC CHIP 10PF	0.5PF 50V
	3-831-441-XX	SPACER		C209	1-135-210-11	TANTALUM CHIP 4.7uF	20% 10V
		< CAPACITOR >		C210	1-135-180-21	TANTALUM CHIP 3.3uF	20% 6.3V
C001	1-164-222-11	CERAMIC CHIP 0.22uF	25V	C213	1-164-161-11	CERAMIC CHIP 0.0022uF	10% 100V
C002	1-164-222-11	CERAMIC CHIP 0.22uF	25V	C217	1-135-259-11	TANTAL. CHIP 10uF	20% 6.3V
C101	1-135-181-21	TANTALUM CHIP 4.7uF	20% 6.3V	C218	1-162-953-11	CERAMIC CHIP 100PF	5% 50V
C102	1-135-259-11	TANTAL. CHIP 10uF	20% 6.3V	C219	1-162-953-11	CERAMIC CHIP 100PF	5% 50V
C103	1-128-019-11	ELECT CHIP 6.8uF	6.3V	C220	1-135-157-21	TANTALUM CHIP 10uF	20% 6.3V
C105	1-162-953-11	CERAMIC CHIP 100PF	5% 50V	C221	1-164-480-11	CERAMIC CHIP 0.01uF	10% 50V
C106	1-128-020-11	ELECT CHIP 10uF	6.3V	C222	1-162-964-11	CERAMIC CHIP 0.001uF	10% 50V
C107	1-162-922-11	CERAMIC CHIP 39PF	5% 50V	C225	1-135-202-21	TANTAL. CHIP 22uF	20% 4V
C108	1-162-915-11	CERAMIC CHIP 10PF	0.5PF 50V	C226	1-104-847-11	TANTAL. CHIP 22uF	20% 4V
C109	1-135-210-11	TANTALUM CHIP 4.7uF	20% 10V	C228	1-163-009-11	CERAMIC CHIP 0.001uF	10% 50V
C110	1-135-180-21	TANTALUM CHIP 3.3uF	20% 6.3V	C229	1-163-022-00	CERAMIC CHIP 0.012uF	10% 50V
C113	1-164-161-11	CERAMIC CHIP 0.0022uF	10% 100V	C231	1-128-014-11	ELECT CHIP 10uF	4V
C117	1-135-259-11	TANTAL. CHIP 10uF	20% 6.3V	C234	1-104-848-11	TANTAL. CHIP 100uF	20% 4V
C118	1-162-953-11	CERAMIC CHIP 100PF	5% 50V	C235	1-135-201-11	TANTALUM CHIP 10uF	20% 4V
C119	1-162-953-11	CERAMIC CHIP 100PF	5% 50V	C302	1-135-210-11	TANTALUM CHIP 4.7uF	20% 10V
C120	1-135-157-21	TANTALUM CHIP 10uF	20% 6.3V	C303	1-135-149-21	TANTALUM CHIP 2.2uF	20% 10V
C121	1-164-480-11	CERAMIC CHIP 0.01uF	10% 50V	C304	1-135-149-21	TANTALUM CHIP 2.2uF	20% 10V
C122	1-162-964-11	CERAMIC CHIP 0.001uF	10% 50V	C305	1-135-259-11	TANTAL. CHIP 10uF	20% 6.3V
C125	1-135-202-21	TANTAL. CHIP 22uF	20% 4V	C306	1-124-779-00	ELECT CHIP 10uF	20% 16V
C126	1-104-847-11	TANTAL. CHIP 22uF	20% 4V	C307	1-135-259-11	TANTAL. CHIP 10uF	20% 6.3V
C128	1-163-009-11	CERAMIC CHIP 0.001uF	10% 50V	C308	1-162-970-11	CERAMIC CHIP 0.01uF	10% 25V
C129	1-163-022-00	CERAMIC CHIP 0.012uF	10% 50V	C309	1-162-638-11	CERAMIC CHIP 1uF	16V
C131	1-128-014-11	ELECT CHIP 10uF	4V	C310	1-124-778-00	ELECT CHIP 22uF	20% 6.3V
C134	1-104-848-11	TANTAL. CHIP 100uF	20% 4V	C311	1-162-970-11	CERAMIC CHIP 0.01uF	10% 25V
C135	1-135-201-11	TANTALUM CHIP 10uF	20% 4V	C312	1-135-259-11	TANTAL. CHIP 10uF	20% 6.3V
				C313	1-162-970-11	CERAMIC CHIP 0.01uF	10% 25V
				C314	1-162-953-11	CERAMIC CHIP 100PF	5% 50V
				C318	1-124-779-00	ELECT CHIP 10uF	20% 16V
				C319	1-126-395-11	ELECT 22uF	20% 16V
				C320	1-216-845-11	METAL CHIP 100K	5% 1/16W
				C322	1-124-778-00	ELECT CHIP 22uF	20% 6.3V

MAIN

Ref. No.	Part No.	Description	Remark
C323	1-164-156-11	CERAMIC CHIP	0.1uF 25V
C324	1-124-778-00	ELECT CHIP	22uF 20% 6.3V
C327	1-104-851-11	TANTAL. CHIP	10uF 20% 10V
C330	1-135-157-21	TANTALUM CHIP	10uF 20% 6.3V
C331	1-164-156-11	CERAMIC CHIP	0.1uF 25V
C332	1-162-970-11	CERAMIC CHIP	0.01uF 10% 25V
C333	1-135-259-11	TANTAL. CHIP	10uF 20% 6.3V
C334	1-135-259-11	TANTAL. CHIP	10uF 20% 6.3V
C335-337	1-162-970-11	CERAMIC CHIP	0.01uF 10% 25V
C338	1-135-210-11	TANTALUM CHIP	4.7uF 20% 10V
C339	1-135-201-11	TANTALUM CHIP	10uF 20% 4V
C340	1-135-091-00	TANTALUM CHIP	1uF 20% 16V
C341	1-135-201-11	TANTALUM CHIP	10uF 20% 4V
C342	1-162-970-11	CERAMIC CHIP	0.01uF 10% 25V
C343	1-104-847-11	TANTAL. CHIP	22uF 20% 4V
C346	1-162-970-11	CERAMIC CHIP	0.01uF 10% 25V
C347	1-135-091-00	TANTALUM CHIP	1uF 20% 16V
C348	1-135-259-11	TANTAL. CHIP	10uF 20% 6.3V
C349	1-128-014-11	ELECT CHIP	10uF 4V
C361	1-135-091-00	TANTALUM CHIP	1uF 20% 16V
C362	1-162-970-11	CERAMIC CHIP	0.01uF 10% 25V
C363	1-135-091-00	TANTALUM CHIP	1uF 20% 16V
C364	1-162-970-11	CERAMIC CHIP	0.01uF 10% 25V
C365	1-104-851-11	TANTAL. CHIP	10uF 20% 10V
C366	1-162-970-11	CERAMIC CHIP	0.01uF 10% 25V
C367	1-135-259-11	TANTAL. CHIP	10uF 20% 6.3V
C368	1-162-970-11	CERAMIC CHIP	0.01uF 10% 25V
C369	1-104-847-11	TANTAL. CHIP	22uF 20% 4V
C370	1-135-157-21	TANTALUM CHIP	10uF 20% 6.3V
C371	1-135-201-11	TANTALUM CHIP	10uF 20% 4V
C372	1-162-970-11	CERAMIC CHIP	0.01uF 10% 25V
C373	1-135-259-11	TANTAL. CHIP	10uF 20% 6.3V
C375	1-135-157-21	TANTALUM CHIP	10uF 20% 6.3V
C377	1-135-201-11	TANTALUM CHIP	10uF 20% 4V
C501	1-164-156-11	CERAMIC CHIP	0.1uF 25V
C502	1-162-970-11	CERAMIC CHIP	0.01uF 10% 25V
C503	1-164-156-11	CERAMIC CHIP	0.1uF 25V
C504	1-164-156-11	CERAMIC CHIP	0.1uF 25V
C505	1-104-851-11	TANTAL. CHIP	10uF 20% 10V
C506	1-135-091-00	TANTALUM CHIP	1uF 20% 16V
C507	1-162-962-11	CERAMIC CHIP	470PF 10% 50V
C508	1-135-091-00	TANTALUM CHIP	1uF 20% 16V
C509	1-162-962-11	CERAMIC CHIP	470PF 10% 50V
C510	1-164-004-11	CERAMIC CHIP	0.1uF 10% 25V
C511	1-164-156-11	CERAMIC CHIP	0.1uF 25V
C513	1-164-004-11	CERAMIC CHIP	0.1uF 10% 25V
C514	1-162-967-11	CERAMIC CHIP	0.0033uF 10% 50V
C517	1-162-970-11	CERAMIC CHIP	0.01uF 10% 25V

Ref. No.	Part No.	Description	Remark
C518	1-162-964-11	CERAMIC CHIP	0.001uF 10% 50V
C519	1-164-156-11	CERAMIC CHIP	0.1uF 25V
C521-523	1-162-964-11	CERAMIC CHIP	0.001uF 10% 50V
C524	1-162-927-11	CERAMIC CHIP	100PF 5% 50V
C525	1-104-852-11	TANTAL. CHIP	22uF 20% 6.3V
C526	1-135-259-11	TANTAL. CHIP	10uF 20% 6.3V
C528	1-162-960-11	CERAMIC CHIP	220PF 10% 50V
C529	1-162-960-11	CERAMIC CHIP	220PF 10% 50V
C530	1-164-156-11	CERAMIC CHIP	0.1uF 25V
C532	1-162-966-11	CERAMIC CHIP	0.0022uF 10% 50V
C533	1-135-091-00	TANTALUM CHIP	1uF 20% 16V
C534	1-162-964-11	CERAMIC CHIP	0.001uF 10% 50V
C535	1-162-964-11	CERAMIC CHIP	0.001uF 10% 50V
C536	1-164-156-11	CERAMIC CHIP	0.1uF 25V
C537	1-135-091-00	TANTALUM CHIP	1uF 20% 16V
C538	1-164-234-11	CERAMIC CHIP	1uF 10V
C539	1-164-234-11	CERAMIC CHIP	1uF 10V
C540	1-104-852-11	TANTAL. CHIP	22uF 20% 10V
C541	1-104-851-11	TANTAL. CHIP	10uF 20% 10V
C542	1-162-970-11	CERAMIC CHIP	0.01uF 10% 25V
C543	1-164-234-11	CERAMIC CHIP	1uF 10V
C544	1-135-091-00	TANTALUM CHIP	1uF 20% 16V
C545	1-135-259-11	TANTAL. CHIP	10uF 20% 6.3V
C546	1-135-259-11	TANTAL. CHIP	10uF 20% 6.3V
C547	1-164-156-11	CERAMIC CHIP	0.1uF 25V
C549-552	1-127-558-11	ELECT(SOLID)	10uF 20% 10V
C553	1-104-852-11	TANTAL. CHIP	22uF 20% 10V
C554	1-127-558-11	ELECT(SOLID)	10uF 20% 10V
C557-559	1-164-227-11	CERAMIC CHIP	0.022uF 10% 25V
C560	1-164-156-11	CERAMIC CHIP	0.1uF 25V
C561	1-162-970-11	CERAMIC CHIP	0.01uF 10% 25V
C562	1-163-038-00	CERAMIC CHIP	0.1uF 25V
C563	1-162-964-11	CERAMIC CHIP	0.001uF 10% 50V
C564	1-162-953-11	CERAMIC CHIP	100PF 5% 50V
C565	1-135-259-11	TANTAL. CHIP	10uF 20% 6.3V
C566	1-162-970-11	CERAMIC CHIP	0.01uF 10% 25V
C567	1-164-156-11	CERAMIC CHIP	0.1uF 25V
C568	1-164-227-11	CERAMIC CHIP	0.022uF 10% 25V
C569-571	1-164-156-11	CERAMIC CHIP	0.1uF 25V
C572	1-135-259-11	TANTAL. CHIP	10uF 20% 6.3V
C573	1-164-156-11	CERAMIC CHIP	0.1uF 25V
C574	1-162-917-11	CERAMIC CHIP	15PF 5% 50V
C575	1-162-917-11	CERAMIC CHIP	15PF 5% 50V
C576	1-104-852-11	TANTAL. CHIP	22uF 20% 10V
C577	1-135-148-21	TANTAL. CHIP	1.5uF 20% 10V

Ref. No.	Part No.	Description	Remark		
C578	1-162-967-11	CERAMIC CHIP	0.0033uF	10%	50V
C579	1-104-852-11	TANTAL. CHIP	22uF	20%	6.3V
C580	1-162-967-11	CERAMIC CHIP	0.0033uF	10%	50V
C581	1-162-970-11	CERAMIC CHIP	0.01uF	10%	25V
C582	1-162-970-11	CERAMIC CHIP	0.01uF	10%	25V
C583	1-135-259-11	TANTAL. CHIP	10uF	20%	6.3V
C584	1-164-156-11	CERAMIC CHIP	0.1uF		25V
C586	1-164-156-11	CERAMIC CHIP	0.1uF		25V
C587	1-162-970-11	CERAMIC CHIP	0.01uF	10%	25V
C588	1-104-755-21	ELECT	88uF	20%	6.3V
C591	1-162-917-11	CERAMIC CHIP	15PF	5%	50V
C592	1-162-910-11	CERAMIC CHIP	5PF	0.25PF	50V
C593	1-162-910-11	CERAMIC CHIP	5PF	0.25PF	50V
C594	1-162-917-11	CERAMIC CHIP	15PF	5%	50V
C595	1-162-915-11	CERAMIC CHIP	10PF	0.5PF	50V
C596	1-162-915-11	CERAMIC CHIP	10PF	0.5PF	50V
C597	1-104-851-11	TANTAL. CHIP	10uF	20%	10V
C598	1-162-970-11	CERAMIC CHIP	0.01uF	10%	25V
C599	1-135-259-11	TANTAL. CHIP	10uF	20%	6.3V
C600	1-162-970-11	CERAMIC CHIP	0.01uF	10%	25V
C601	1-164-156-11	CERAMIC CHIP	0.1uF		25V
C602	1-164-156-11	CERAMIC CHIP	0.1uF		25V
C605	1-104-851-11	TANTAL. CHIP	10uF	20%	10V
C606	1-162-970-11	CERAMIC CHIP	0.01uF	10%	25V
C608	1-162-970-11	CERAMIC CHIP	0.01uF	10%	25V
C609	1-164-234-11	CERAMIC CHIP	1uF		10V
C610	1-164-156-11	CERAMIC CHIP	0.1uF		25V
C611	1-164-156-11	CERAMIC CHIP	0.1uF		25V
C613	1-162-966-11	CERAMIC CHIP	0.0022uF	10%	50V
C614	1-162-966-11	CERAMIC CHIP	0.0022uF	10%	50V
C615	1-164-234-11	CERAMIC CHIP	1uF		10V
C616	1-164-156-11	CERAMIC CHIP	0.1uF		25V
C617	1-162-964-11	CERAMIC CHIP	0.001uF	10%	50V
C618	1-162-923-11	CERAMIC CHIP	47PF	5%	50V
C620	1-162-966-11	CERAMIC CHIP	0.0022uF	10%	50V
C621	1-162-979-11	CERAMIC CHIP	0.0027uF	10%	50V
C622	1-162-953-11	CERAMIC CHIP	100PF	5%	50V
C624	1-162-970-11	CERAMIC CHIP	0.01uF	10%	25V
C627	1-164-234-11	CERAMIC CHIP	1uF		10V
C1000	1-104-852-11	TANTAL. CHIP	22uF	20%	6.3V
C1002	1-162-638-11	CERAMIC CHIP	1uF		16V
C2001	1-162-964-11	CERAMIC CHIP	0.001uF	10%	50V
C2002	1-164-234-11	CERAMIC CHIP	1uF		10V
C2004	1-164-234-11	CERAMIC CHIP	1uF		10V
C2005	1-135-179-21	TANTAL. CHIP	2.2uF	20%	16V
C2008	1-164-234-11	CERAMIC CHIP	1uF		10V
C2009	1-162-968-11	CERAMIC CHIP	0.0047uF	10%	50V
C3001	1-135-148-21	TANTALUM CHIP	1.5uF	20%	10V
C3002	1-135-149-21	TANTALUM CHIP	2.2uF	20%	10V

Ref. No.	Part No.	Description	Remark		
< CONNECTOR >					
CN501	1-750-374-11	CONNECTOR, FPC 14P			
* CN502	1-691-419-11	HOUSING, CONNECTOR 8P			
CN504	1-569-530-11	HOUSING, CONNECTOR 16P			
* CN505	1-691-798-11	HOUSING, CONNECTOR 22P			
CN507	1-750-375-11	CONNECTOR, FPC 22P			
CN508	1-750-377-11	SOCKET, CONNECTOR 7P (REMOTE DIGITAL I/O)			
CN509	1-750-373-11	CONNECTOR, FPC 8P			
< DC-DC CONVERTER UNIT >					
CP501	1-467-045-11	CONVERTER UNIT, DC-DC			
< DIODE >					
D102-104	8-719-033-14	LED CL-170PG-CD-T			
D202-204	8-719-033-14	LED CL-170PG-CD-T			
D301	8-719-105-58	DIODE RD3.9M-B2			
D303	8-719-975-43	DIODE RB420D			
D331	8-719-975-43	DIODE RB420D			
D332	8-719-975-43	DIODE RB420D			
D340	8-719-975-43	DIODE RB420D			
D341	8-719-975-43	DIODE RB420D			
D501-503	8-719-980-38	DIODE SB07-03C			
D505	8-719-404-16	DIODE MA713			
D506-509	8-719-800-76	DIODE 1SS226			
D510	8-719-026-26	DIODE MA786WK			
D511	8-719-105-91	DIODE RD5.6M-B2			
D512	8-719-404-35	DIODE MA141WK			
D515	8-719-820-05	DIODE 1SS181			
D516	8-719-820-05	DIODE 1SS181			
D517	8-719-989-73	DIODE SB007T03C			
D518	8-719-404-35	DIODE MA141WK			
< IC >					
IC301	8-759-745-64	IC NJM4560M			
IC302	8-759-161-76	IC TK15021MTL			
IC303	8-759-097-92	IC NJM2100V			
IC304	8-759-161-74	IC AK5344-VS-E1			
IC305	8-759-501-41	IC SM5840BS			
IC308	8-759-058-41	IC NJM3416V			
IC311	8-759-178-39	IC PCM69AU-J-T1			
IC313	8-759-097-92	IC NJM2100V			
IC314	8-759-161-75	IC NJM2112V(TE2)			
IC315	8-759-168-90	IC TK11245TL			
IC501	8-759-094-01	IC MB3796PFV-G-BND-ER			

MAIN

Ref. No.	Part No.	Description	Remark
IC502	8-759-094-02	IC CXA8022N	
IC503	8-759-164-58	IC MCD002BM-TLM	
IC504	8-759-159-76	IC MM1138XQ	
IC505	8-759-168-66	IC RH5RE40AA-T1	
IC506	8-752-843-07	IC CXP80524-078R	
IC507	8-759-159-77	IC TK10502MT1	
IC508	8-752-352-24	IC CXD2605R	
IC509	8-759-031-84	IC SC7S04F	
IC510	8-752-343-47	IC CXK58257ATM-12LB	
IC511	8-759-031-84	IC SC7S04F	
IC2001	8-759-178-44	IC RN5VL33AA-T1	
		< JACK >	
J301	1-750-369-11	JACK (MIC)	
J302	1-750-370-11	JACK (LINE IN)	
J304	1-750-372-11	JACK (PHONES/LINE OUT)	
J501	1-750-368-11	JACK, DC (POLARITY UNIFIED TYPE) (DC IN 6V)	
		< COIL >	
L101-103			
	1-410-997-31	INDUCTOR CHIP 2.2uH	
L201-203			
	1-410-997-31	INDUCTOR CHIP 2.2uH	
L301	1-412-006-31	INDUCTOR CHIP 10uH	
L305	1-410-999-11	INDUCTOR CHIP 3.3uH	
L307	1-410-997-31	INDUCTOR CHIP 2.2uH	
L391	1-410-997-31	INDUCTOR CHIP 2.2uH	
L501	1-410-997-31	INDUCTOR CHIP 2.2uH	
L502	1-412-002-31	INDUCTOR CHIP 4.7uH	
L503	1-412-002-31	INDUCTOR CHIP 4.7uH	
L504	1-410-997-31	INDUCTOR CHIP 2.2uH	
L505	1-424-213-11	INDUCTOR 100uH	
L506	1-414-214-11	INDUCTOR 200uH	
L507	1-412-006-31	INDUCTOR CHIP 10uH	
L508	1-410-997-31	INDUCTOR CHIP 2.2uH	
L509	1-410-997-31	INDUCTOR CHIP 2.2uH	
L510	1-410-196-11	INDUCTOR CHIP 2.2uH	
L511	1-216-295-00	METAL CHIP 0 5% 1/10W	
L512	1-410-997-31	INDUCTOR CHIP 2.2uH	
L1001	1-410-997-31	INDUCTOR CHIP 2.2uH	
		< TRANSISTOR >	
Q102	8-729-400-55	TRANSISTOR 2SD1328-S	
Q106	8-729-402-32	TRANSISTOR 2SD1819A-R	
Q202	8-729-400-55	TRANSISTOR 2SD1328-S	
Q206	8-729-402-32	TRANSISTOR 2SD1819A-R	
Q301	8-729-141-48	TRANSISTOR 2SB624-BV345	
Q302	8-729-216-22	TRANSISTOR 2SA1162-G	

Ref. No.	Part No.	Description	Remark
Q303	8-729-402-19	TRANSISTOR XN6501	
Q304	8-729-402-93	TRANSISTOR UN5214	
Q305	8-729-230-49	TRANSISTOR 2SC2712-YG	
Q306	8-729-159-65	TRANSISTOR 2SD596-DV5	
Q307	8-729-900-52	TRANSISTOR DTC114YK	
Q308	8-729-425-18	TRANSISTOR XN4504	
Q309	8-729-402-93	TRANSISTOR UN5214	
Q311	8-729-402-32	TRANSISTOR 2SD1819A-R	
Q312	8-729-216-22	TRANSISTOR 2SA1162-G	
Q313	8-729-230-49	TRANSISTOR 2SC2712-YG	
Q314	8-729-402-19	TRANSISTOR XN6501	
Q316	8-729-402-93	TRANSISTOR UN5214	
Q317	8-729-427-83	TRANSISTOR XP6501	
Q318	8-729-427-83	TRANSISTOR XP6501	
Q331	8-729-402-32	TRANSISTOR 2SD1819A-R	
Q332	8-729-216-22	TRANSISTOR 2SA1162-G	
Q333	8-729-402-32	TRANSISTOR 2SD1819A-R	
Q334	8-729-230-60	TRANSISTOR 2SA1586-YG	
Q353	8-729-230-60	TRANSISTOR 2SA1586-YG	
Q354	8-729-402-32	TRANSISTOR 2SD1819A-R	
Q355-357			
	8-729-402-93	TRANSISTOR UN5214	
Q361	8-729-216-22	TRANSISTOR 2SA1162-G	
Q362	8-729-402-19	TRANSISTOR XN6501	
Q363	8-729-216-22	TRANSISTOR 2SA1162-G	
Q364	8-729-402-19	TRANSISTOR XN6501	
Q365	8-729-402-32	TRANSISTOR 2SD1819A-R	
Q366	8-729-402-32	TRANSISTOR 2SD1819A-R	
Q367	8-729-427-83	TRANSISTOR XP6501	
Q368	8-729-425-44	TRANSISTOR XP4315	
Q501	8-729-820-86	TRANSISTOR 2SB1121-ST	
Q502	8-729-820-86	TRANSISTOR 2SB1121-ST	
Q503	8-729-422-18	TRANSISTOR XN4315	
Q504	8-729-216-22	TRANSISTOR 2SA1162-G	
Q505	8-729-015-76	TRANSISTOR UN5211	
Q508	8-729-230-49	TRANSISTOR 2SC2712-YG	
Q509	8-729-230-49	TRANSISTOR 2SC2712-YG	
Q512	8-729-015-74	TRANSISTOR UN5111	
Q514	8-729-140-75	TRANSISTOR 2SD999-CLCK	
Q515	8-729-805-26	TRANSISTOR 2SB1121-T	
Q516	8-729-402-45	TRANSISTOR UN5212	
Q517	8-729-402-96	TRANSISTOR UN5114	
Q518	8-729-924-62	TRANSISTOR DTC113ZU	
Q519	8-729-216-22	TRANSISTOR 2SA1162-G	
Q2001	8-729-402-45	TRANSISTOR UN5212	
Q3001	8-729-420-50	TRANSISTOR UN5215	

Ref. No.	Part No.	Description	Remark
< RESISTOR >			
R101	1-216-830-11	METAL CHIP	5.6K 5% 1/16W
R102	1-216-864-11	METAL CHIP	0 5% 1/16W
R103	1-218-740-11	METAL CHIP	100K 0.50% 1/16W
R104	1-218-716-11	METAL CHIP	10K 0.50% 1/16W
R105	1-216-821-11	METAL CHIP	1K 5% 1/16W
R106	1-216-830-11	METAL CHIP	5.6K 5% 1/16W
R108	1-218-724-11	METAL CHIP	22K 0.50% 1/16W
R109	1-216-809-11	METAL CHIP	100 5% 1/16W
R110	1-218-873-11	METAL CHIP	12K 0.50% 1/16W
R111	1-216-821-11	METAL CHIP	1K 5% 1/16W
R113	1-218-736-11	METAL CHIP	68K 0.50% 1/16W
R115	1-218-716-11	METAL CHIP	10K 0.50% 1/16W
R116	1-218-716-11	METAL CHIP	10K 0.50% 1/16W
R120	1-218-694-91	METAL CHIP	1.2K 0.50% 1/16W
R121	1-216-864-11	METAL CHIP	0 5% 1/16W
R122	1-218-672-11	METAL CHIP	150 0.50% 1/16W
R123	1-218-672-11	METAL CHIP	150 0.50% 1/16W
R127	1-216-804-11	METAL CHIP	39 5% 1/16W
R129	1-218-724-11	METAL CHIP	22K 0.50% 1/16W
R130	1-216-809-11	METAL CHIP	100 5% 1/16W
R132	1-216-802-11	METAL GLAZE	27 5% 1/16W
R133	1-216-848-11	METAL CHIP	180K 5% 1/16W
R136	1-216-817-11	METAL CHIP	470 5% 1/16W
R137	1-218-295-11	METAL CHIP	5.6K 0.50% 1/16W
R138	1-218-716-11	METAL CHIP	10K 0.50% 1/16W
R140	1-216-864-11	METAL CHIP	0 5% 1/16W
R151	1-218-670-11	METAL CHIP	120 0.50% 1/16W
R152	1-216-821-11	METAL CHIP	1K 5% 1/16W
R153	1-218-484-11	METAL CHIP	750 0.50% 1/16W
R155	1-218-695-11	METAL CHIP	1.3K 0.50% 1/16W
R156	1-216-804-11	METAL CHIP	39 5% 1/16W
R157	1-216-841-11	METAL CHIP	47K 5% 1/16W
R158	1-216-821-11	METAL CHIP	1K 5% 1/16W
R159	1-216-821-11	METAL CHIP	1K 5% 1/16W
R160	1-218-700-11	METAL CHIP	2.2K 0.50% 1/16W
R162	1-218-716-11	METAL CHIP	10K 0.50% 1/16W
R164	1-216-821-11	METAL CHIP	1K 5% 1/16W
R173	1-216-845-11	METAL CHIP	100K 5% 1/16W
R174	1-216-837-11	METAL CHIP	22K 5% 1/16W
R177	1-216-833-11	METAL CHIP	10K 5% 1/16W
R178	1-218-732-11	METAL CHIP	47K 0.50% 1/16W
R179	1-218-732-11	METAL CHIP	47K 0.50% 1/16W
R180	1-216-809-11	METAL CHIP	100 5% 1/16W
R181	1-216-833-11	METAL CHIP	10K 5% 1/16W
R201	1-216-830-11	METAL CHIP	5.6K 5% 1/16W
R202	1-216-864-11	METAL CHIP	0 5% 1/16W
R203	1-218-740-11	METAL CHIP	100K 0.50% 1/16W

Ref. No.	Part No.	Description	Remark
R204	1-218-716-11	METAL CHIP	10K 0.50% 1/16W
R205	1-216-821-11	METAL CHIP	1K 5% 1/16W
R206	1-216-830-11	METAL CHIP	5.6K 5% 1/16W
R208	1-218-724-11	METAL CHIP	22K 0.50% 1/16W
R209	1-216-809-11	METAL CHIP	100 5% 1/16W
R210	1-218-873-11	METAL CHIP	12K 0.50% 1/16W
R211	1-216-821-11	METAL CHIP	1K 5% 1/16W
R213	1-218-736-11	METAL CHIP	68K 0.50% 1/16W
R215	1-218-716-11	METAL CHIP	10K 0.50% 1/16W
R216	1-218-716-11	METAL CHIP	10K 0.50% 1/16W
R220	1-218-694-11	METAL CHIP	1.2K 0.50% 1/16W
R221	1-216-864-11	METAL CHIP	0 5% 1/16W
R222	1-218-672-11	METAL CHIP	150 0.50% 1/16W
R223	1-218-672-11	METAL CHIP	150 0.50% 1/16W
R227	1-216-804-11	METAL CHIP	39 5% 1/16W
R229	1-218-724-11	METAL CHIP	22K 0.50% 1/16W
R230	1-216-809-11	METAL CHIP	100 5% 1/16W
R232	1-216-802-11	METAL GLAZE	27 5% 1/16W
R233	1-216-848-11	METAL CHIP	180K 5% 1/16W
R236	1-216-817-11	METAL CHIP	470 5% 1/16W
R237	1-218-295-11	METAL CHIP	5.6K 0.50% 1/16W
R238	1-218-716-11	METAL CHIP	10K 0.50% 1/16W
R240	1-216-864-11	METAL CHIP	0 5% 1/16W
R251	1-218-670-11	METAL CHIP	120 0.50% 1/16W
R252	1-216-821-11	METAL CHIP	1K 5% 1/16W
R253	1-218-484-11	METAL CHIP	750 0.50% 1/16W
R255	1-218-695-11	METAL CHIP	1.3K 0.50% 1/16W
R256	1-216-804-11	METAL CHIP	39 5% 1/16W
R257	1-216-841-11	METAL CHIP	47K 5% 1/16W
R258	1-216-821-11	METAL CHIP	1K 5% 1/16W
R259	1-216-821-11	METAL CHIP	1K 5% 1/16W
R260	1-218-700-11	METAL CHIP	2.2K 0.50% 1/16W
R262	1-218-716-11	METAL CHIP	10K 0.50% 1/16W
R264	1-216-821-11	METAL CHIP	1K 5% 1/16W
R273	1-216-845-11	METAL CHIP	100K 5% 1/16W
R274	1-216-837-11	METAL CHIP	22K 5% 1/16W
R277	1-216-833-11	METAL CHIP	10K 5% 1/16W
R278	1-218-732-11	METAL CHIP	47K 0.50% 1/16W
R279	1-218-732-11	METAL CHIP	47K 0.50% 1/16W
R280	1-216-809-11	METAL CHIP	100 5% 1/16W
R281	1-216-833-11	METAL CHIP	10K 5% 1/16W
R301	1-216-815-11	METAL CHIP	330 5% 1/16W
R304	1-216-841-11	METAL CHIP	47K 5% 1/16W
R305	1-216-845-11	METAL CHIP	100K 5% 1/16W
R306	1-216-853-11	METAL CHIP	470K 5% 1/16W
R307	1-216-821-11	METAL CHIP	1K 5% 1/16W
R308	1-216-821-11	METAL CHIP	1K 5% 1/16W
R309	1-218-732-11	METAL CHIP	47K 0.50% 1/16W
R310	1-218-732-11	METAL CHIP	47K 0.50% 1/16W

MAIN

Ref. No.	Part No.	Description	Remark		
R312	1-216-834-11	METAL CHIP	12K	5%	1/16W
R313	1-216-825-11	METAL CHIP	2.2K	5%	1/16W
R314	1-216-833-11	METAL CHIP	10K	5%	1/16W
R315	1-216-825-11	METAL CHIP	2.2K	5%	1/16W
R316	1-216-825-11	METAL CHIP	2.2K	5%	1/16W
R317	1-216-851-11	METAL CHIP	330K	5%	1/16W
R318	1-216-825-11	METAL CHIP	2.2K	5%	1/16W
R319	1-216-825-11	METAL CHIP	2.2K	5%	1/16W
R320	1-216-821-11	METAL CHIP	1K	5%	1/16W
R321	1-216-833-11	METAL CHIP	10K	5%	1/16W
R322	1-216-833-11	METAL CHIP	10K	5%	1/16W
R323	1-216-864-11	METAL CHIP	0	5%	1/16W
R327	1-164-156-11	CERAMIC CHIP	0.1uF		25V
R330	1-218-732-11	METAL CHIP	47K	0.50%	1/16W
R331	1-218-732-11	METAL CHIP	47K	0.50%	1/16W
R332	1-216-827-11	METAL CHIP	3.3K	5%	1/16W
R334	1-216-833-11	METAL CHIP	10K	5%	1/16W
R336	1-216-821-11	METAL CHIP	1K	5%	1/16W
R337	1-216-091-00	METAL CHIP	10	5%	1/16W
R338	1-216-864-11	METAL CHIP	0	5%	1/16W
R342	1-216-834-11	METAL CHIP	12K	5%	1/16W
R343	1-216-848-11	METAL CHIP	180K	5%	1/16W
R344	1-216-821-11	METAL CHIP	1K	5%	1/16W
R351	1-216-833-11	METAL CHIP	10K	5%	1/16W
R352	1-216-854-11	METAL CHIP	560K	5%	1/16W
R353	1-216-863-11	METAL GLAZE	3.3M	5%	1/16W
R355	1-216-854-11	METAL CHIP	560K	5%	1/16W
R356	1-216-821-11	METAL CHIP	1K	5%	1/16W
R357	1-216-863-11	METAL GLAZE	3.3M	5%	1/16W
R358	1-216-841-11	METAL CHIP	47K	5%	1/16W
R359	1-216-857-11	METAL CHIP	1M	5%	1/16W
R360	1-216-821-11	METAL CHIP	1K	5%	1/16W
R361	1-216-833-11	METAL CHIP	10K	5%	1/16W
R365	1-216-001-00	METAL CHIP	10	5%	1/16W
R366	1-216-809-11	METAL CHIP	100	5%	1/16W
R371	1-216-821-11	METAL CHIP	1K	5%	1/16W
R372	1-216-854-11	METAL CHIP	560K	5%	1/16W
R373	1-216-833-11	METAL CHIP	10K	5%	1/16W
R374	1-216-827-11	METAL CHIP	3.3K	5%	1/16W
R375	1-216-857-11	METAL CHIP	1M	5%	1/16W
R376	1-216-841-11	METAL CHIP	47K	5%	1/16W
R377	1-216-821-11	METAL CHIP	1K	5%	1/16W
R378	1-216-809-11	METAL CHIP	100	5%	1/16W
R379	1-216-834-11	METAL CHIP	12K	5%	1/16W
R380	1-216-848-11	METAL CHIP	180K	5%	1/16W
R381	1-216-830-11	METAL CHIP	5.6K	5%	1/16W
R382	1-216-834-11	METAL CHIP	12K	5%	1/16W
R383	1-216-829-11	METAL CHIP	4.7K	5%	1/16W
R384	1-216-848-11	METAL CHIP	180K	5%	1/16W

Ref. No.	Part No.	Description	Remark		
R385	1-216-823-11	METAL CHIP	1.5K	5%	1/16W
R386	1-218-732-11	METAL CHIP	47K	0.50%	1/16W
R387	1-218-732-11	METAL CHIP	47K	0.50%	1/16W
R389	1-218-732-11	METAL CHIP	47K	0.50%	1/16W
R390	1-218-732-11	METAL CHIP	47K	0.50%	1/16W
R392-395					
	1-216-833-11	METAL CHIP	10K	5%	1/16W
R396	1-218-295-11	METAL CHIP	5.6K	0.50%	1/16W
R397	1-216-839-11	METAL CHIP	33K	5%	1/16W
R398	1-216-809-11	METAL CHIP	100	5%	1/16W
R399	1-216-809-11	METAL CHIP	100	5%	1/16W
R400	1-216-849-11	METAL CHIP	220K	5%	1/16W
R401	1-216-809-11	METAL CHIP	100	5%	1/16W
R402	1-216-809-11	METAL CHIP	100	5%	1/16W
R501	1-216-794-11	METAL CHIP	5.6	5%	1/16W
R502	1-216-828-11	METAL CHIP	3.9K	5%	1/16W
R503	1-216-813-11	METAL CHIP	220	5%	1/16W
R504	1-216-830-11	METAL CHIP	5.6K	5%	1/16W
R505	1-216-794-11	METAL CHIP	5.6	5%	1/16W
R506	1-216-794-11	METAL CHIP	5.6	5%	1/16W
R508	1-216-843-11	METAL CHIP	68K	5%	1/16W
R509	1-216-811-11	METAL CHIP	150	5%	1/16W
R510	1-216-843-11	METAL CHIP	68K	5%	1/16W
R511	1-216-840-11	METAL CHIP	39K	5%	1/16W
R512-514					
	1-216-834-11	METAL CHIP	12K	5%	1/16W
R516	1-216-023-00	METAL CHIP	82	5%	1/16W
R517	1-216-813-11	METAL CHIP	220	5%	1/16W
R518	1-217-806-11	METAL GLAZE	1	5%	1/8W
R519	1-217-806-11	METAL GLAZE	1	5%	1/8W
R520	1-216-841-11	METAL CHIP	47K	5%	1/16W
R521	1-216-833-11	METAL CHIP	10K	5%	1/16W
R522	1-216-833-11	METAL CHIP	10K	5%	1/16W
R523	1-216-832-11	METAL CHIP	8.2K	5%	1/16W
R524	1-216-828-11	METAL CHIP	3.9K	5%	1/16W
R525	1-216-844-11	METAL CHIP	82K	5%	1/16W
R526	1-216-843-11	METAL CHIP	68K	5%	1/16W
R527	1-216-829-11	METAL CHIP	4.7K	5%	1/16W
R528	1-216-826-11	METAL CHIP	2.7K	5%	1/16W
R529	1-218-734-11	METAL CHIP	56K	0.50%	1/16W
R530	1-216-826-11	METAL CHIP	2.7K	5%	1/16W
R531	1-216-825-11	METAL CHIP	2.2K	5%	1/16W
R533	1-218-748-11	METAL CHIP	220K	0.50%	1/16W
R534	1-218-748-11	METAL CHIP	220K	0.50%	1/16W
R535-539					
	1-216-837-11	METAL CHIP	22K	5%	1/16W
R540-542					
	1-216-845-11	METAL CHIP	100K	5%	1/16W
R544	1-216-833-11	METAL CHIP	10K	5%	1/16W

Ref. No.	Part No.	Description	Remark		
R545	1-216-801-11	METAL CHIP	22	5%	1/16W
R546	1-216-833-11	METAL CHIP	10K	5%	1/16W
R547	1-216-829-11	METAL CHIP	4.7K	5%	1/16W
R548	1-216-829-11	METAL CHIP	4.7K	5%	1/16W
R549	1-216-833-11	METAL CHIP	10K	5%	1/16W
R550	1-216-174-00	METAL GLAZE	100	5%	1/8W
R551	1-216-839-11	METAL CHIP	33K	5%	1/16W
R552	1-216-834-11	METAL CHIP	12K	5%	1/16W
R553	1-218-676-11	METAL CHIP	220	0.50%	1/16W
R554	1-216-839-11	METAL CHIP	33K	5%	1/16W
R555	1-216-811-11	METAL CHIP	150	5%	1/16W
R556	1-216-818-11	METAL CHIP	560	5%	1/16W
R557	1-216-818-11	METAL CHIP	560	5%	1/16W
R558	1-218-676-11	METAL CHIP	220	0.50%	1/16W
R559	1-218-740-11	METAL CHIP	100K	0.50%	1/16W
R560	1-216-817-11	METAL CHIP	470	5%	1/16W
R561	1-216-821-11	METAL CHIP	1K	5%	1/16W
R564	1-216-864-11	METAL CHIP	0	5%	1/16W
R565	1-216-843-11	METAL CHIP	68K	5%	1/16W
R566	1-216-817-11	METAL CHIP	470	5%	1/16W
R567	1-216-837-11	METAL CHIP	22K	5%	1/16W
R568	1-216-809-11	METAL CHIP	100	5%	1/16W
R569	1-216-841-11	METAL CHIP	47K	5%	1/16W
R570-572					
	1 216 809 11	METAL CHIP	100	5%	1/16W
R573	1-216-841-11	METAL CHIP	47K	5%	1/16W
R574	1-216-817-11	METAL CHIP	470	5%	1/16W
R575	1-216-845-11	METAL CHIP	100K	5%	1/16W
R576	1-216-833-11	METAL CHIP	10K	5%	1/16W
R577	1-216-845-11	METAL CHIP	100K	5%	1/16W
R578	1-216-842-11	METAL CHIP	56K	5%	1/16W
R579	1-216-838-11	METAL CHIP	27K	5%	1/16W
R580	1-216-838-11	METAL CHIP	27K	5%	1/16W
R581	1-216-835-11	METAL CHIP	15K	5%	1/16W
R582	1-216-794-11	METAL CHIP	5.6	5%	1/16W
R583	1-216-825-11	METAL CHIP	2.2K	5%	1/16W
R584	1-216 825 11	METAL CHIP	2.2K	5%	1/16W
R585	1-218-873-11	METAL CHIP	12K	0.50%	1/16W
R586	1-218-732-11	METAL CHIP	47K	0.50%	1/16W
R587	1-216-829-11	METAL CHIP	4.7K	5%	1/16W
R588	1-216-819-11	METAL CHIP	680	5%	1/16W
R589	1-216-849-11	METAL CHIP	220K	5%	1/16W
R590	1-216-849-11	METAL CHIP	220K	5%	1/16W
R592	1-216-843-11	METAL CHIP	68K	5%	1/16W
R593	1-216-843-11	METAL CHIP	68K	5%	1/16W
R596-598					
	1-216-845-11	METAL CHIP	100K	5%	1/16W
R599	1-216-854-11	METAL CHIP	560K	5%	1/16W
R600	1-216-829-11	METAL CHIP	4.7K	5%	1/16W

Ref. No.	Part No.	Description	Remark		
R601	1-216-833-11	METAL CHIP	10K	5%	1/16W
R602	1-216-812-11	METAL CHIP	180	5%	1/16W
R608	1-216-816-11	METAL CHIP	390	5%	1/16W
R609	1-216-849-11	METAL CHIP	220K	5%	1/16W
R610	1-216-837-11	METAL CHIP	22K	5%	1/16W
R611	1-216-838-11	METAL CHIP	27K	5%	1/16W
R614	1 216-841-11	METAL CHIP	47K	5%	1/16W
R2001	1-216 845-11	METAL CHIP	100K	5%	1/16W
R2002	1-216-854-11	METAL CHIP	560K	5%	1/16W
R2003	1-216-845-11	METAL CHIP	100K	5%	1/16W
R2004	1-216-851-11	METAL CHIP	330K	5%	1/16W
R2005	1-216-844-11	METAL CHIP	82K	5%	1/16W
R3001	1-216-837-11	METAL CHIP	22K	5%	1/16W
R3002	1-216-841-11	METAL CHIP	47K	5%	1/16W
R3003	1-216-821-11	METAL CHIP	1K	5%	1/16W
< VARIABLE RESISTOR >					
RV301	1 223-361-11	RES, VAR, CARBON 20K/20K (REC LEVEL)			
RV501	1-238-667-21	RES, ADJ, GERMET 100K			
< SWITCH >					
S301	1-571-277-11	SWITCH, SLIDE (MIC SENS)			
S302	1-571-506-41	SWITCH, SLIDE (REC MODF)			
S501	1-571-275-31	SWITCH, SLIDE (SP/LP)			
< VIBRATOR >					
X501	1-579-924-11	VIBRATOR, CRYSTAL (CHIP TYPE) (9.408MHz)			
X502	1 579 924-11	VIBRATOR, CRYSTAL (CHIP TYPE) (9.408MHz)			
X503	1-579-923-11	VIBRATOR, CRYSTAL (CHIP TYPE) (22.5792MHz)			
X504	1-579-922-11	VIBRATOR, CRYSTAL (CHIP TYPE) (24.576MHz)			

TRANSFORMER

Ref. No.	Part No.	Description	Remark		
*		TRANSFORMER BOARD (SUPPLIED WITH MAIN BOARD, COMPLETE) *****			
		< CAPACITOR >			
C589	1-162-967-11	CERAMIC CHIP	0.0033uF	10%	50V
C590	1-164-234-11	CERAMIC CHIP	1uF		10V
C612	1-125-507-11	DOUBLE LAYERS	0.22F		5.5V
		< TRANSFORMER >			
1VT501	1-423-601-11	TRANSFORMER, OSCILLATION			
		< TRANSISTOR >			
Q513	8-729-120-28	TRANSISTOR	2SC1623-L5L6		
		< RESISTOR >			
R562	1-216-821-11	METAL CHIP	1K	5%	1/16W
R563	1-218-736-11	METAL CHIP	68K	0.50%	1/16W
