

TC-WR770/WR875

SERVICE MANUAL

US Model
TC-WR875

AEP Model
UK Model
TC-WR770



This photo is TC-WR875.

Model Name Using Similar Mechanism	TC-WR97ES/WR870
Tape Transport Mechanism Type	TCM-200R5

SPECIFICATIONS

Recording system 4-track 2-channel stereo
Fast winding time Approx. 90 sec. (with Sony C-60 cassette)
Bias AC bias
Signal-to-noise ratio (at peak level)

Dolby NR switch	OFF	B-Type ON	C-Type ON
Cassette			
Type IV (Sony METAL-S)	58 dB	66 dB	73 dB
Type II (Sony UX-S)	57 dB	65 dB	72 dB
Type I (Sony HF-S)	55 dB	63 dB	70 dB

Total harmonic distortion 1.0% (with Sony METAL-S cassettes)

Frequency response (DOLBY NR OFF)

Type IV cassette (Sony METAL-S)	30 - 18,000 Hz (± 3 dB, IEC) 30 - 14,000 Hz (± 3 dB 0VU(-4dB) recording)
Type II cassette (Sony UX-S)	30 - 17,000 Hz (± 3 dB, IEC)
Type I cassette (Sony HF-S)	30 - 15,000 Hz (± 3 dB, IEC)

Wow and flutter $\pm 0.09\%$ W.Peak (IEC)
 0.06% WRMS (NAB)
 $\pm 0.16\%$ W.Peak (DIN)

Inputs

Line inputs (phono jacks)	Sensitivity	77.5 mV
	Input impedance	47 k ohms

Outputs

Line outputs (phono jacks)	Rated output level	0.32 V at a load impedance of 47 k ohms
	Load impedance	Over 10 k ohms
Headphones (stereo phone jack)	Output level	0 - 1.25 mW at a load impedance of 32 ohms

General

Power requirements

US model:
120V AC, 60Hz
AEP, Germany model:
220-230V AC, 50/60Hz
UK model:
240V AC, 50/60Hz

Power consumption

29 W

Dimensions

Approx. 430 x 135 x 355 mm (w/h/d)
(17 x 5 $\frac{3}{8}$ x 14 inches)
including projecting parts and controls

Weight

Approx. 6.3 kg (13 lbs 15 oz)

Supplied accessory

Audio connecting cords (2)

Design and specifications subject to change without notice.



STEREO CASSETTE DECK
SONY[®]

FEATURES

For higher quality recording/playback

- **The Dolby HX PRO* system** which improves the linearity of the tape's high-range response during recording.
- **B and C type Dolby NR* systems** which reduce tape noise.
- **Bias calibration** to achieve the optimum bias current setting for any tape (Deck B only).

For your convenience

- **Quick reversing** at the end of a tape to minimize interruptions during playback and recording.
- **Automatic tape type detection** during playback and recording.
- **The AMS, Blank Skip and Memory Play functions** which provide easy access to a desired selection.
- **A relay function** for long recording and playback.
- **Auto Play function** which automatically starts playback after tape rewinding to start.
- **Timer-activated playback and recording** through the use of an optional timer.
- **Synchronized dubbing** at normal or high speed.
- **Simultaneous Recording function** for the simultaneous recording of the same source to cassettes in both decks.

For easier operation

- **Twin easy-to-read digital linear counters** which show the elapsed recording or playing time.

* Dolby noise reduction and HX Pro headroom extension manufactured under license from Dolby Laboratories Licensing Corporation. HX Pro originated by Bang & Olufsen.

DOLBY, the double-D symbol $\square\square$ and "HX PRO" are trademarks of Dolby Laboratories Licensing Corporation.

SAFETY CHECK-OUT (US Model)

After correcting the original service problem, perform the following safety check before releasing the set to the customer:

Check the antenna terminals, metal trim, "metallized" knobs, screws, and all other exposed metal parts for AC leakage. Check leakage as described below.

LEAKAGE TEST

The AC leakage from any exposed metal part to earth ground and from all exposed metal parts to any exposed metal part having a return to chassis, must not exceed 0.5 mA (500 microamperes). Leakage current can be measured by any one of three methods.

1. A commercial leakage tester, such as the Simpson 229 or RCA WT-540A. Follow the manufacturers' instructions to use these instruments.
2. A battery-operated AC milliammeter. The Data Precision 245 digital multimeter is suitable for this job.
3. Measuring the voltage drop across a resistor by means of a VOM or battery-operated AC voltmeter. The "limit" indication is 0.75 V, so analog meters must have an accurate low-voltage scale. The Simpson 250 and Sanwa SH-63Trd are examples of a passive VOM that is suitable. Nearly all battery operated digital multimeters that have a 2V AC range are suitable. (See Fig. A)

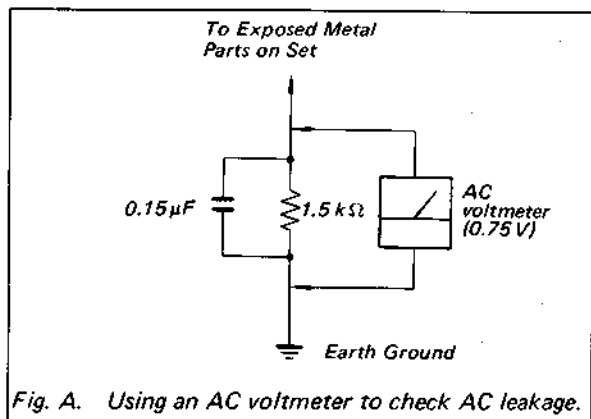

Dolby noise reduction manufactured under license from Dolby Laboratories Licensing Corporation. "DOLBY" and the double-D symbol $\square\square$ are trademarks of Dolby Laboratories Licensing Corporation.

SAFETY-RELATED COMPONENT WARNING!!

COMPONENTS IDENTIFIED BY MARK \triangle OR DOTTED LINE WITH MARK \triangle ON THE SCHEMATIC DIAGRAMS AND IN THE PARTS LIST ARE CRITICAL TO SAFE OPERATION. REPLACE THESE COMPONENTS WITH SONY PARTS WHOSE PART NUMBERS APPEAR AS SHOWN IN THIS MANUAL OR IN SUPPLEMENTS PUBLISHED BY SONY.

MODEL IDENTIFICATION

— Specification Label —

TC-WR770: AEP, UK, Germany model

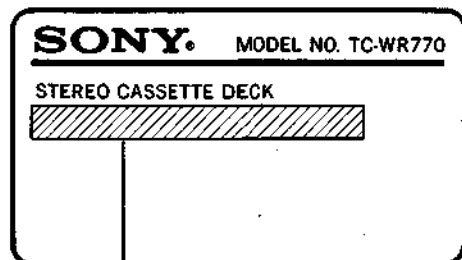

AEP, Germany model: AC 220V-230V ~ 50/60Hz
 UK model : AC 240V ~ 50/60Hz

TC-WR875: US model

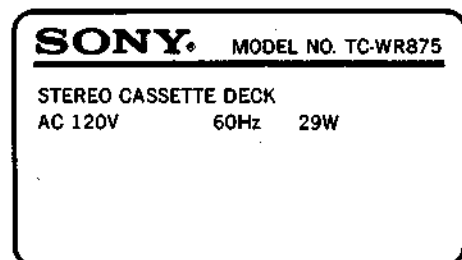

TABLE OF CONTENTS

<u>Section</u>	<u>Title</u>	<u>Page</u>
1. GENERAL		
•	Identification of Front Panel Parts	4
2. DISASSEMBLY		
2-1.	Cassette Lid Assy	5
2-2.	Front Panel Assy	5
2-3.	Mechanism Desk Block	5
2-4.	Cassette Holder	6
2-5.	Ornamental Plate	6
2-6.	Pinch Lever, Head	7
2-7.	Capstan Motor, Flywheel	7
2-8.	Bracket (Motor R1) Assy	8
2-9.	Reel Motor Board	8
3. MECHANICAL ADJUSTMENTS		9
4. ELECTRICAL ADJUSTMENTS		9
5. DIAGRAMS		
5-1.	Block Diagram	13
5-2.	Circuit Boards	16
5-3.	Semiconductor Lead Layouts	16
5-4.	Printed Wiring Boards —Display/Deck/SW Section—	17
5-5.	Schematic Diagram —System Control/Display/Deck/SW Section—	19
5-6.	Schematic Diagram —Audio/Power Section—	23
5-7.	Printed Wiring Boards —Audio/System Control/Power Section—	27
6. EXPLODED VIEWS		
6-1.	Chassis Section	30
6-2.	Front Panel Section	31
6-3.	Mechanism Deck Section 1	32
6-4.	Mechanism Deck Section 2	33
7. ELECTRICAL PARTS LIST		34

SECTION 1
GENERAL

This section is extracted from instruction manual.

● TC-WR875

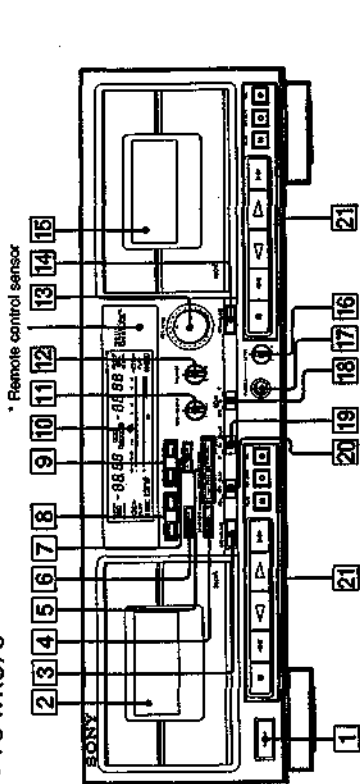

For details, refer to the page number indicated in ●.

- 1 POWER switch
- 2 Deck A
- 3 ▲ OPEN/CLOSE button (deck A)
- 4 A-B REC (simultaneous recording) button
- 5 SYNCHRO DUBBING buttons (HIGH SPEED button, NORM (normal) SPEED button)
- 6 BLANK SKIP button
- 7 AUTO PAUSE button
- 8 COUNTER buttons (deck A) (RESET button, MEMORY button)
- 9 COUNTER buttons (deck B)
- 10 RESET button
- 11 MEMORY button
- 12 Display panel
- 13 BIAS control (deck B)
- 14 BALANCE control
- 15 REC (recording) LEVEL control
- 16 REC (recording) button
- 17 ▲ OPEN/CLOSE button (deck B)
- 18 Deck B
- 19 PHONES (headphones) jack (stereo phone jack)
- 20 DO NR (Dolby noise reduction) switch
- 21 DIR (direction) MODE switch
- 22 TIMER switch
- 23 Tape operation buttons (stop) button, (leftward fast winding) (AMS**), (reverse play) button, (rightward fast winding) (AMS**), PAUSE button, REC MUTE (record muting) button, REC (recording) button

* Remote control sensor
You can remotely control this cassette deck with:
— A remote commander that came with a Sony amplifier or receiver if it has the ■ mark and cassette deck control capability.
— Any optional Sony remote commander with the ■ mark and cassette deck control capability.

**AMS is an abbreviation for Automatic Music Sensor.

Identification of Front Panel Parts

● TC-WR770

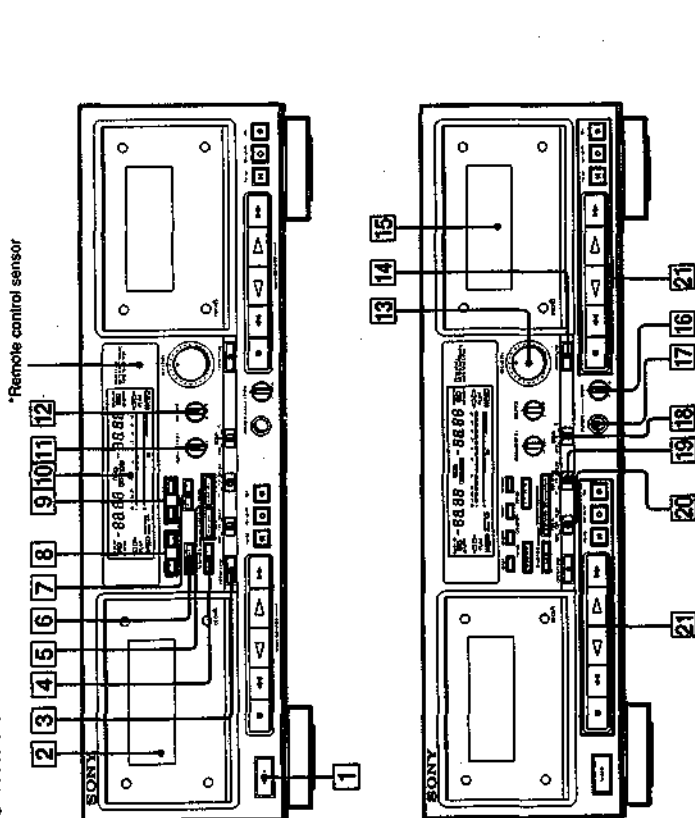

For details, refer to the page number indicated in ●.

- 1 POWER switch
- 2 Deck A
- 3 ▲ OPEN/CLOSE button (deck A)
- 4 A-B REC (simultaneous recording) button
- 5 SYNCHRO DUBBING buttons (HIGH SPEED button, NORM (normal) SPEED button)
- 6 BLANK SKIP button
- 7 AUTO PAUSE button
- 8 COUNTER buttons (deck A) (RESET button, MEMORY button)
- 9 COUNTER buttons (deck B)
- 10 RESET button
- 11 MEMORY button
- 12 Display panel
- 13 BIAS control (deck B)
- 14 BALANCE control
- 15 REC (recording) LEVEL control
- 16 REC (recording) button
- 17 ▲ OPEN/CLOSE button (deck B)
- 18 Deck B
- 19 PHONES (headphones) jack (stereo phone jack)
- 20 DO NR (Dolby noise reduction) switch
- 21 DIR (direction) MODE switch
- 22 TIMER switch
- 23 Tape operation buttons (stop) button, (leftward fast winding) (AMS**), (reverse play) button, (rightward fast winding) (AMS**), PAUSE button, REC MUTE (record muting) button, REC (recording) button

**AMS is an abbreviation for Automatic Music Sensor.

* Remote control sensor
You can remotely control this cassette deck with:
— A remote commander that came with a Sony amplifier or receiver if it has the ■ mark and cassette deck control capability.
— Any optional Sony remote commander with the ■ mark and cassette deck control capability.

SECTION 2 DISASSEMBLY

Note: Follow the disassembly procedure in the numerical order given.

2-1. CASSETTE LID ASSY

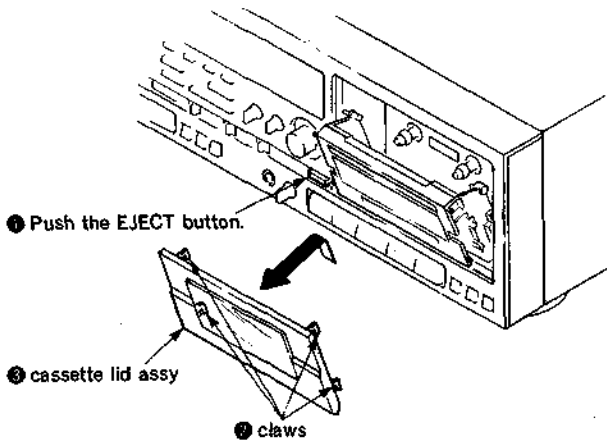

2-2. FRONT PANEL ASSY

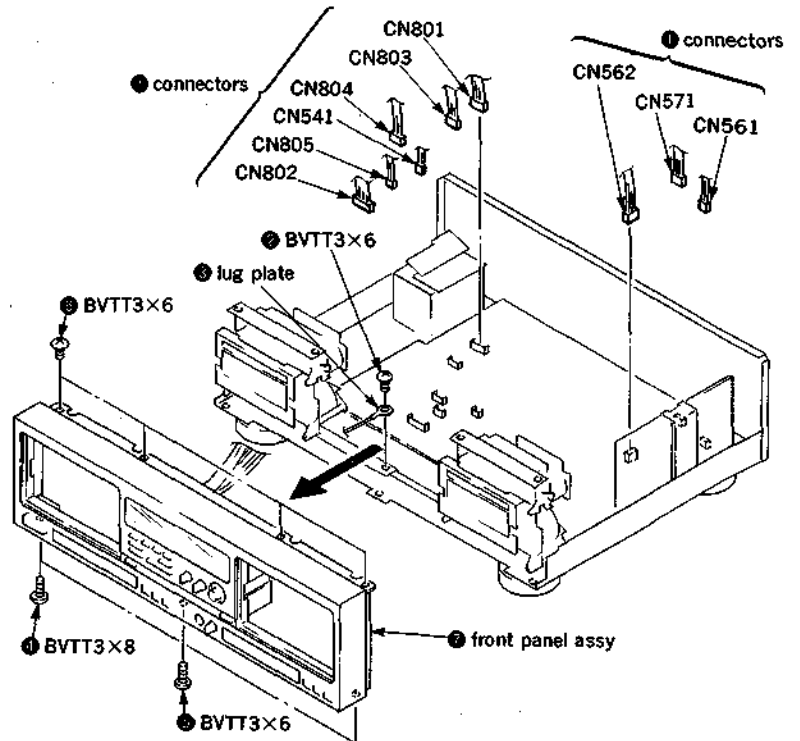

2-3. MECHANISM DECK BLOCK

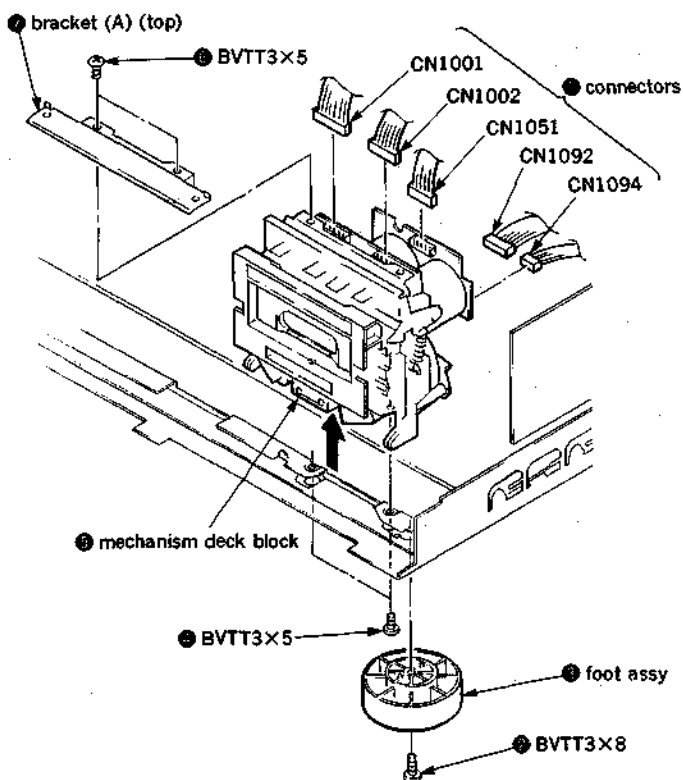

2-4. CASSETTE HOLDER

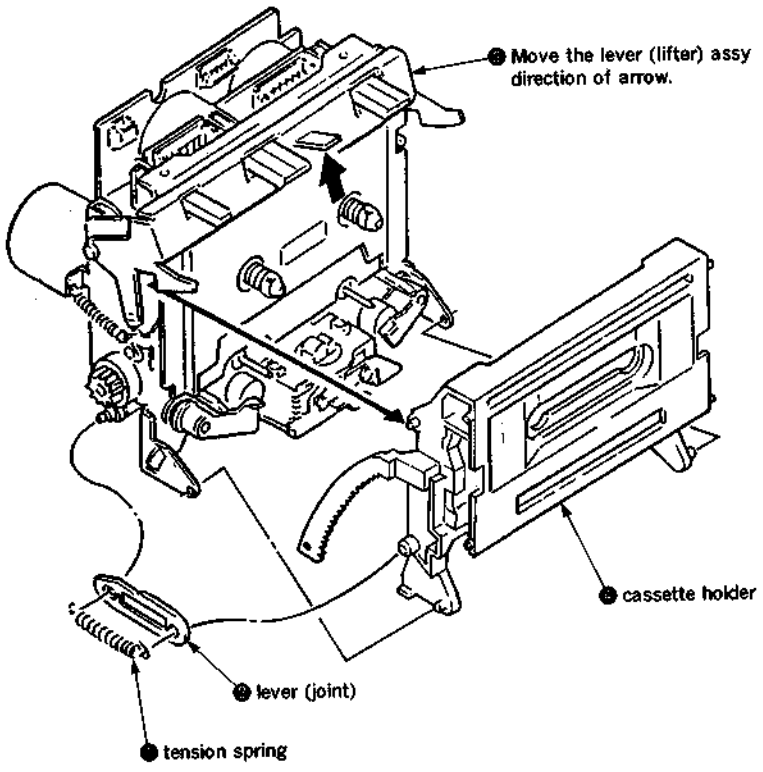

2-5. ORNAMENTAL PLATE

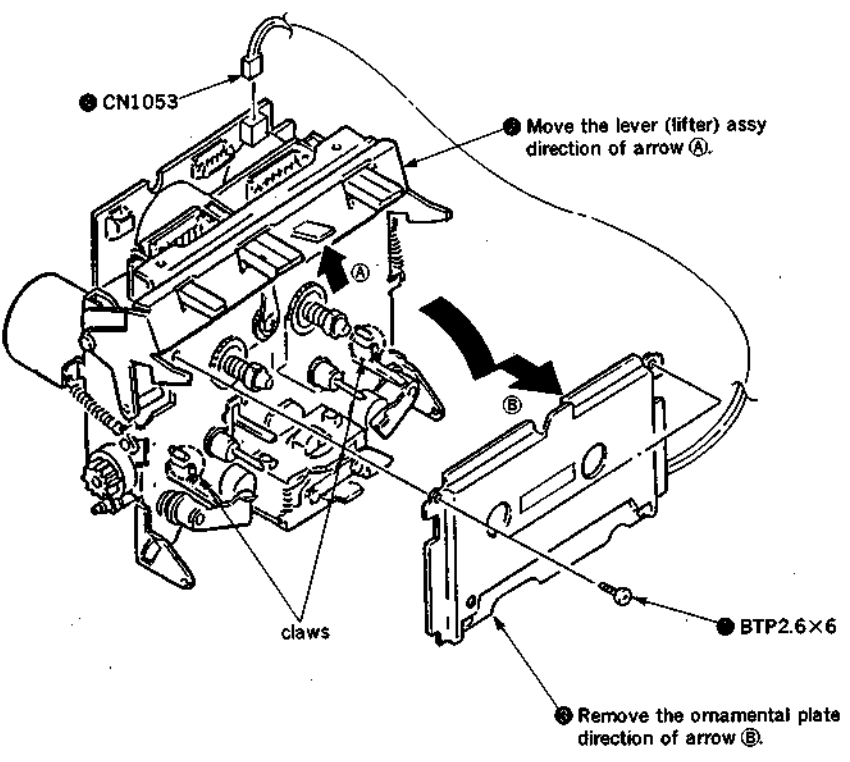

2-6. PINCH LEVER, HEAD

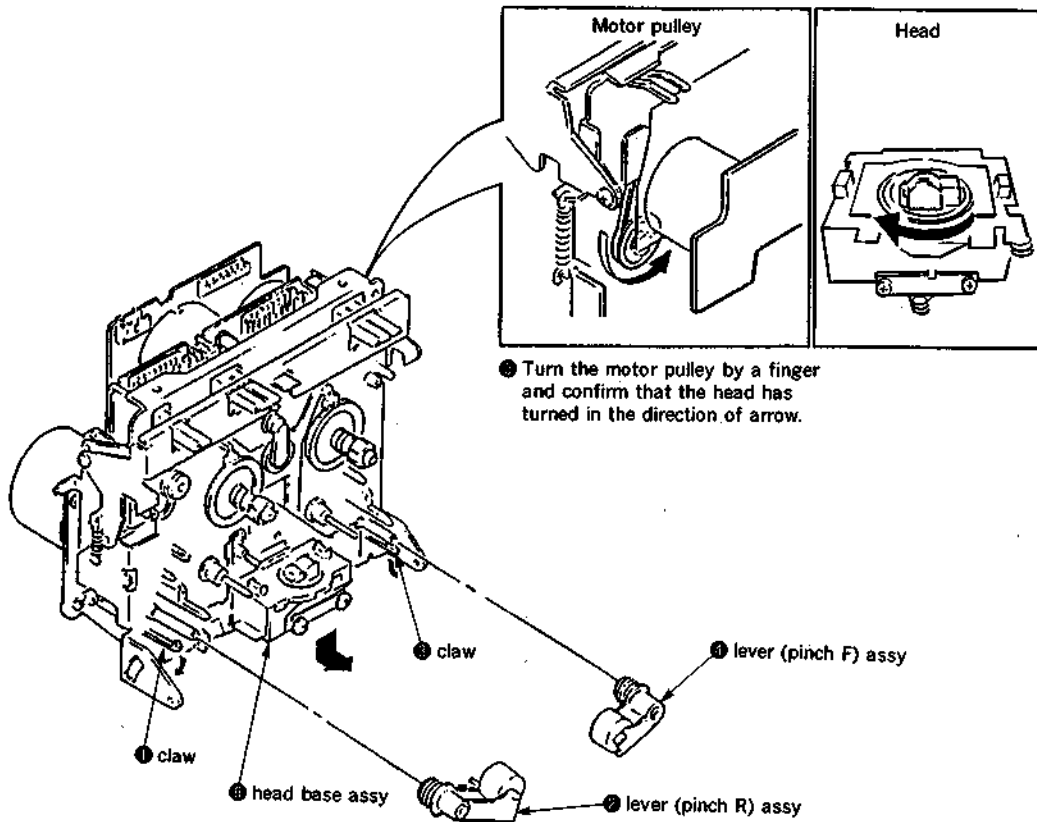

2-7. CAPSTAN MOTOR, FLYWHEEL

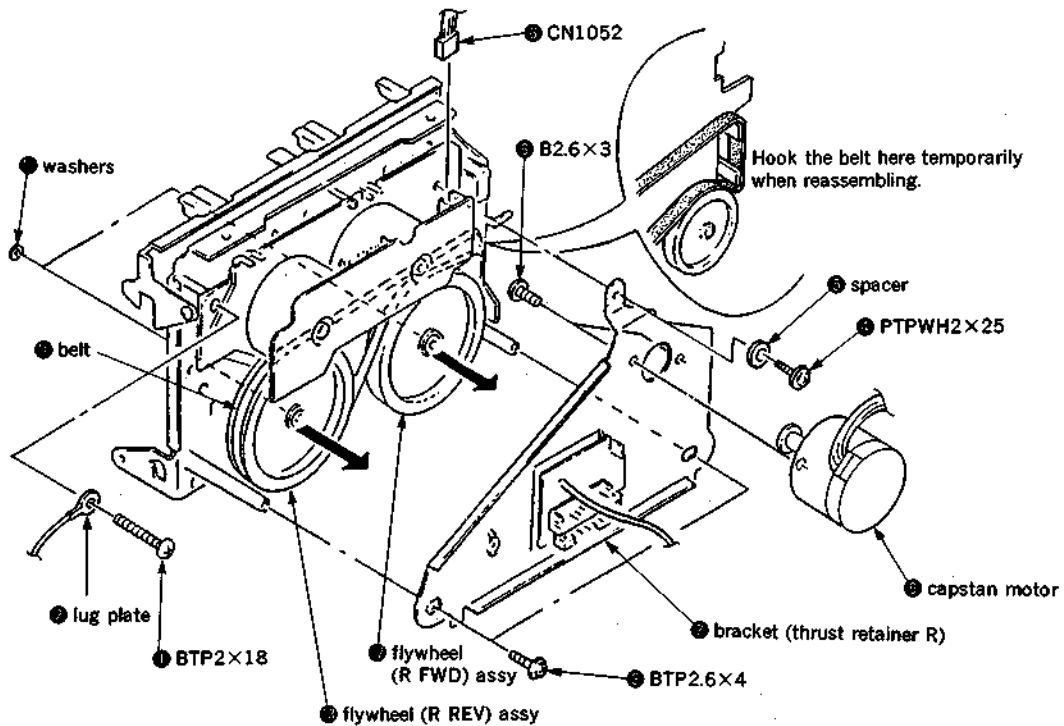

2-8. BRACKET (MOTOR R1) ASSY

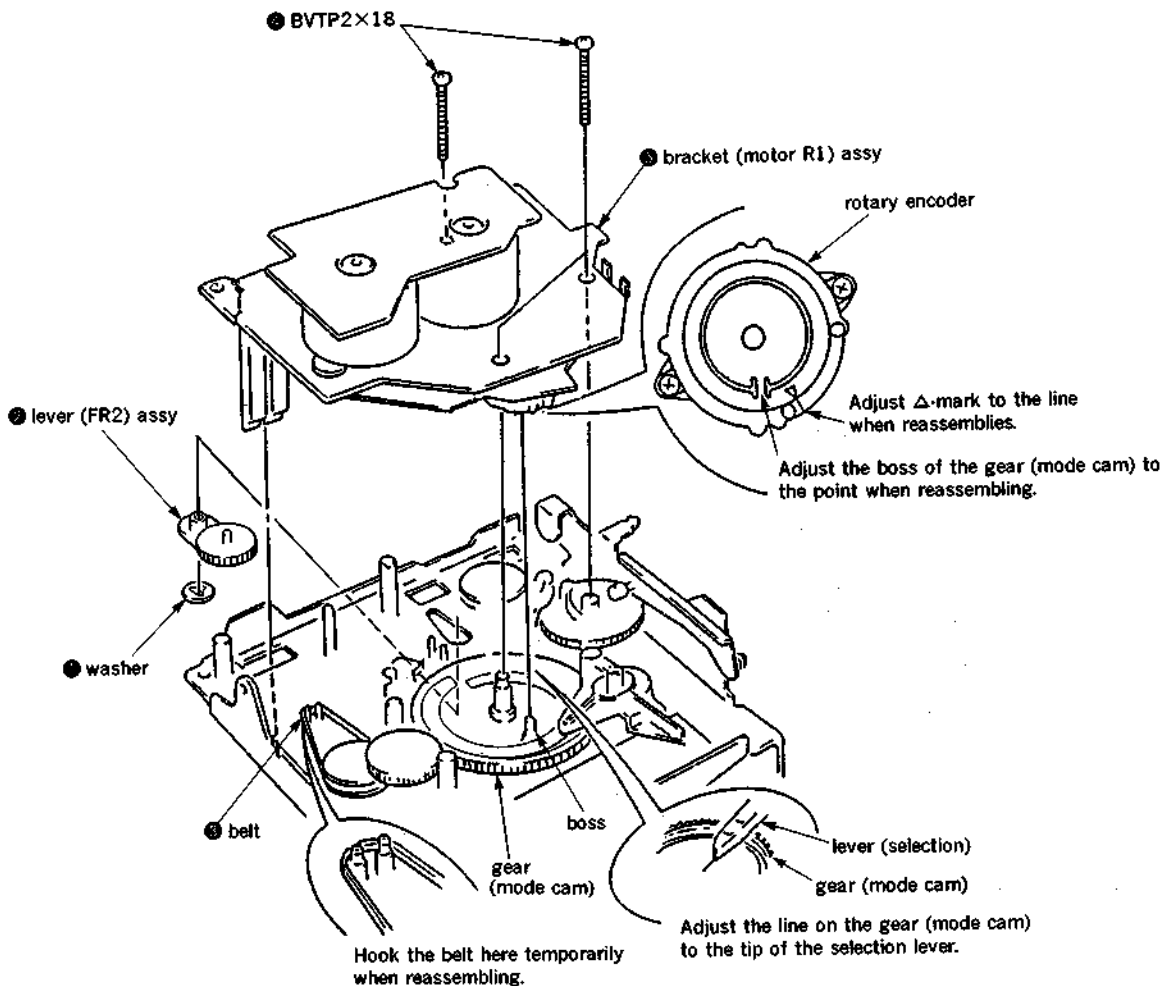

2-9. REEL MOTOR BOARD

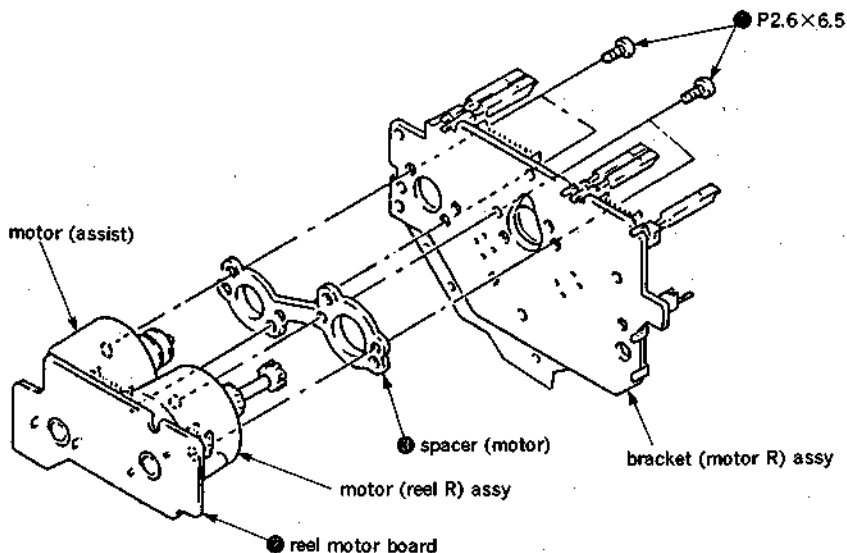

SECTION 3 MECHANICAL ADJUSTMENTS

PRECAUTION

- Clean the following parts with a denatured-alcohol-moistened swab :

record/playback/erase head	pinch roller
capstan	rubber belts
idler	
- Demagnetize the record/playback head with a head demagnetizer.
- Do not use a magnetized screwdriver for the adjustments.
- After the adjustments, apply suitable locking compound to the parts adjusted.
- The adjustments should be performed in the rated power supply voltage unless otherwise noted.

Torque Measurement

Torque	Torque meter	Meter reading
FWD	CQ-102C	30—60g·cm (0.42—0.83 oz·inch)
FWD back tension	CQ-102C	1—5g·cm (0.014—0.063 oz·inch)
REV	CQ-102RC	30—60g·cm (0.42—0.83 oz·inch)
REV back tension	CQ-102RC	1—5g·cm (0.014—0.063 oz·inch)
FF, REW	CQ-201B	65—90g·cm (0.90—1.25 oz·inch)

SECTION 4 ELECTRICAL ADJUSTMENTS

Note : The adjustment should be performed in the order given in the service manual. As a rule, adjustments about playback should be performed before those about recording. The adjustments should be performed for both L-CH and R-CH.

Switches and controls should be set as follows unless otherwise specified.

- (dolby) switch : OFF
- DIR MODE switch : \Rightarrow
- TIMER switch : OFF

Standard Record :

Deliver the standard input signal level to the input jack and set the REC LEVEL control to obtain the standard output signal level.

—Record Mode—

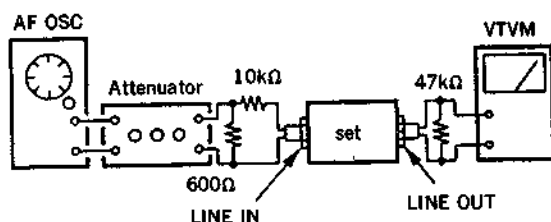

0 dB = 775mV

Standard Input Level

Input terminal	LINE IN
source impedance	10k Ω
input level	0.25V (-10dB)

Standard Output Level

Output terminal	LINE OUT
load impedance	47k Ω
output level	0.32V (-7.7dB)

Test tape

Type	Signal	Used for
P-4-A100	10kHz, -10dB	Azimuth Adjustment
WS-48B	3kHz, 0dB	Tape Speed Adjustment
P-4-L300	315Hz, 0dB	PB Level Adjustment

The set will get into TEST MODE by shorting the pins of TP801 (TEST) on main board before turning the power on and TEST MODE functions as follows :

- High speed playback
Pushing HIGH SPEED DUBBING button while playback changes to high speed playback and another push of the button returns the set to normal speed playback.
- Record memory stop
When starting recording, tape counter is reset to zero and counter memory turned on.

Record/Playback Head Azimuth Adjustment

DECK A **DECK B**

Procedure :

- Mode: FWD playback

Test tape
P-4-A100
(10kHz, -10dB)

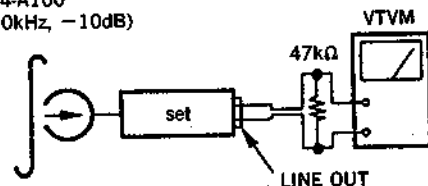

- Turn the adjustment screw for the maximum output levels. If these levels do not match, turn the adjustment screw until both of output levels match together within 1dB.

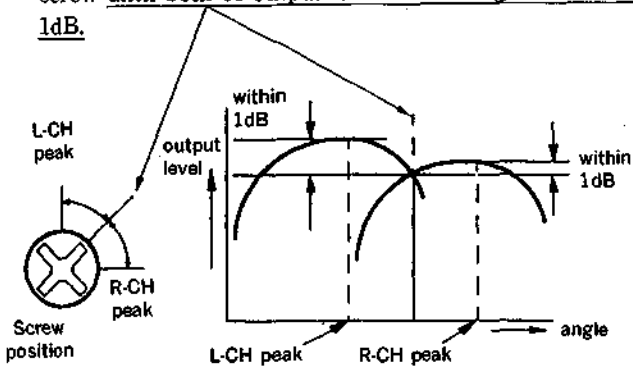

- Phase Check
Mode : playback

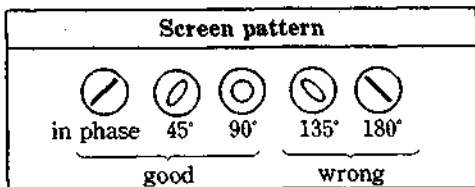
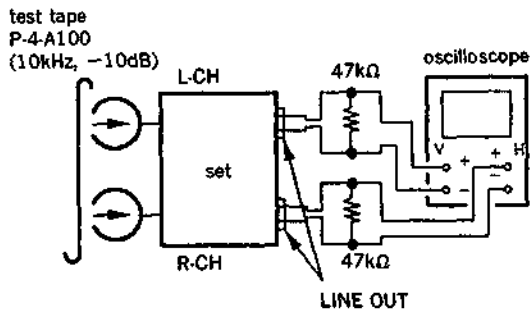

- Set in the REV mode and repeat the steps 1-3.
- After the adjustment, lock the screws with locking compound.

Adjustment Location : record/playback head

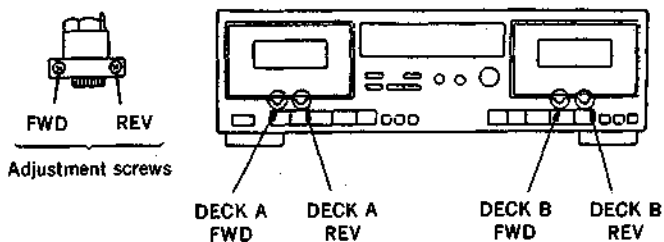

Tape Speed Adjustment [DECK A] [DECK B]

Procedure :

Mode : playback

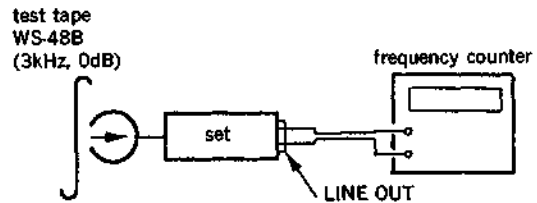

(high speed adjustment)

- Short test pin TP801 (TEST) on main board.
- Set to FWD playback mode.
- Push the HIGH SPEED DUBBING button.
- Adjust RV871 (DECK A) and RV881 (DECK B) on main board so that the frequency counter reading becomes $6,000 \pm 30\text{Hz}$.
- After adjustment, disconnect TP801 shorted in step 1.

(normal speed adjustment)

- Set to FWD playback mode.
- Adjust RV872 (DECK A) and RV882 (DECK B) on main board so that the frequency counter reading becomes $3,000 \pm 15\text{Hz}$.

Frequency difference between the beginning and the end of the tape should be within 5%.

Frequency difference between deck A and deck B should be within 60Hz (high speed) or 30Hz (normal speed).

Adjustment Location : main board (See page 12.)

Playback Level Adjustment [DECK A] [DECK B]

Procedure :

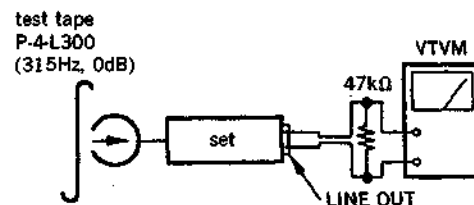

Adjust RV131 (L-CH) and RV231 (R-CH) for DECK A and RV151 (L-CH) and RV251 (R-CH) for DECK B so that the reading on VTVM meets the adjustment limits next page.

Adjustment Limits :

LINE OUT level : $-20 \pm 0.5\text{dB}$ (73.2-83.0mV)

Level difference between channels : less than 0.5dB

Check that the LINE OUT level does not change even if playback and stop operation is repeated several times.

Adjustment Location : main board (See page.12.)

Bias Current Adjustment

Procedure :

1. Set the RV121 (L-CH) and RV221 (R-CH) for DECK A and RV141 (L-CH) and RV214 (R-CH) for DECK B to mechanical center and turn the set recording mode.
2. Connect digital voltmeter as shown by the following table.
3. Adjust the following transformers for the minimum readings on the digital voltmeter.

DECK	Measurement point	Adjustment	Value
A	L ① and ②, TP521	T121	less than 140mV
	R ② and ③, TP521	T221	
B	L ① and ②, TP541	T141	
	R ② and ③, TP541	T241	

Adjustment Location : main board (See page 12.)

Record Bias Adjustment

DECK A DECK B

Setting :

REC LEVEL control : Standard Record (See page 9.)

Test pin TP801 : short

Procedure :

1. Mode : record

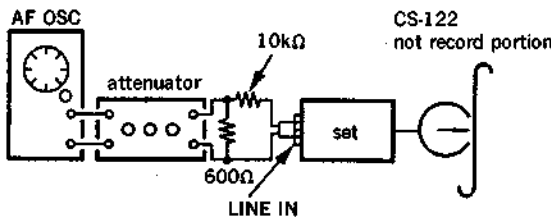

- 1) 315Hz } 24.5mV (-30dB)
- 2) 10kHz }

2. Mode : playback

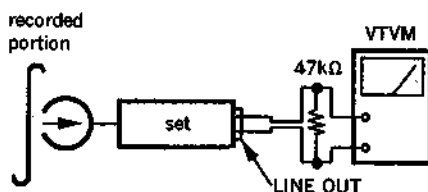

3. Playback the signal recorded in step 1.
4. Confirm that the 10kHz playback output is $0 \pm 0.5\text{dB}$ relative to the 315Hz output. If necessary, adjust the RV121 (L-CH) and RV221 (R-CH) for DECK A and RV141 (L-CH) and RV241 (R-CH) for DECK B, and repeat the steps 1-2.

Adjustment Location : main board (See page 12.)

Record Level Adjustment

DECK A DECK B

Setting :

REC LEVEL control : Standard Record (See page 9.)

Test pin TP801 : short

Procedure :

1. Mode : record

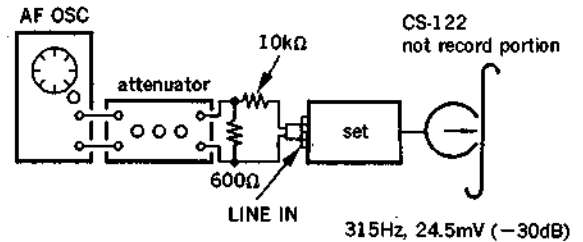

2. Mode : playback

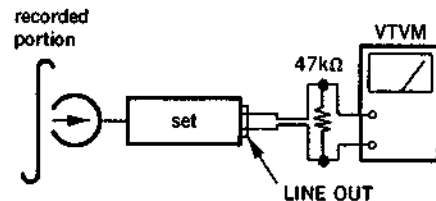

3. Playback the signal recorded in step 1.
4. Confirm that the signal level is within the adjustment limits below. If necessary, adjust the RV301 (L-CH) and RV401 (R-CH) for DECK A and RV351 (L-CH) and RV451 (R-CH) for DECK B, and repeat the steps 1-2.

Adjustment Limits : $-30 \text{ dB} \pm 0.5\text{dB}$ (23.1-26.0mV)

Adjustment Location : REC EQ board (See page 12.)

Quick Reverse Sensitivity Adjustment

DECK A DECK B

Setting :

DIR MODE switch : \rightleftarrows

Adjustment procedure :

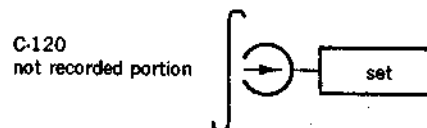

1. Connect the digital voltmeter to test point TP802 (DECK A) / TP803 (DECK B).
2. Load C-120 cassette tape and playback the leading portion in FWD mode.
3. Adjust the RV841 (DECK A) and RV831 (DECK B) for $4.5 \pm 0.5\text{V}$ reading on the digital voltmeter.
4. Playback C-120 cassette tape in FWD mode again.
5. Confirm that the reading on the digital voltmeter is "L" level at the magnetic portion of the tape.
6. Confirm that the tape stop around the tape end (border of the leading and the magnetic portions).

Adjustment Location : main board (See page 12.)

Adjustment Location : main board and REC EQ board
 — main board (component side) —

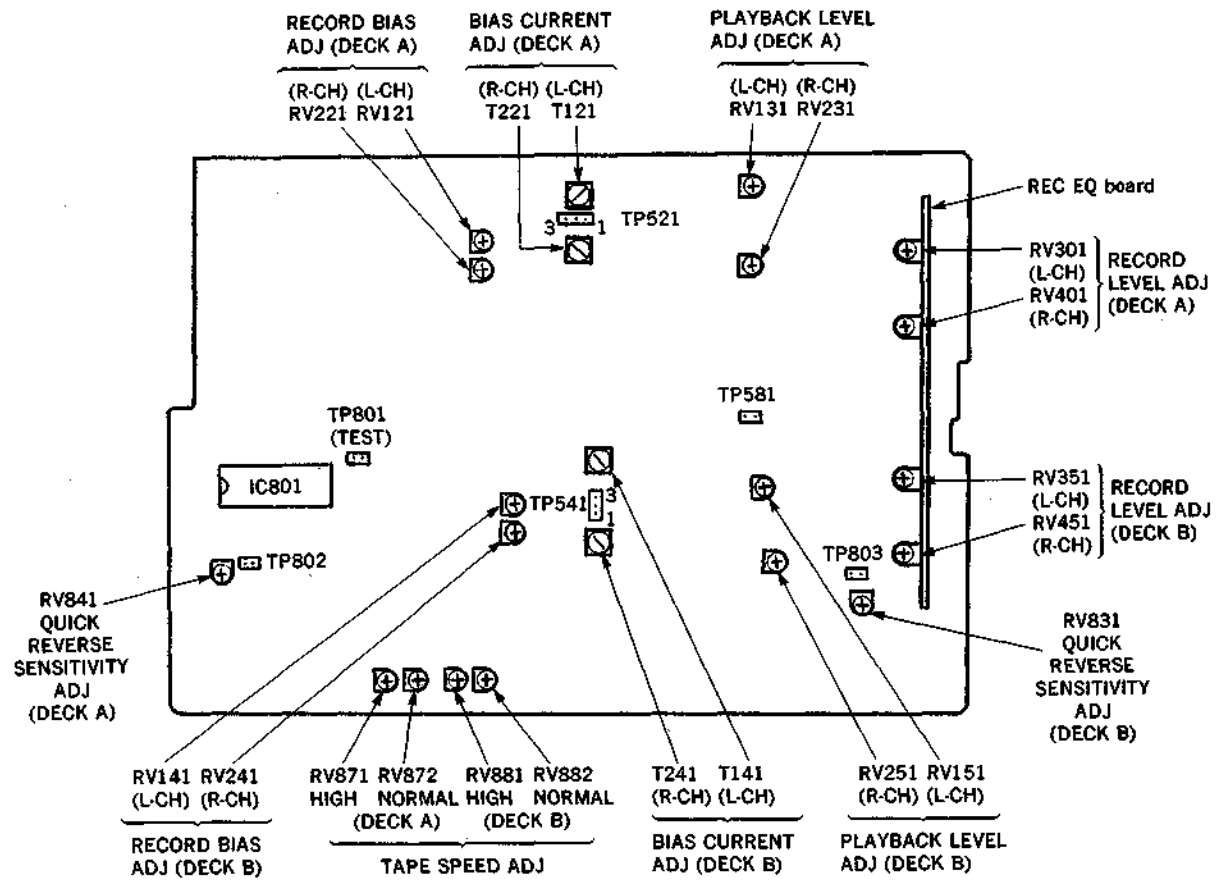

SECTION 5 DIAGRAMS

5-1. BLOCK DIAGRAM

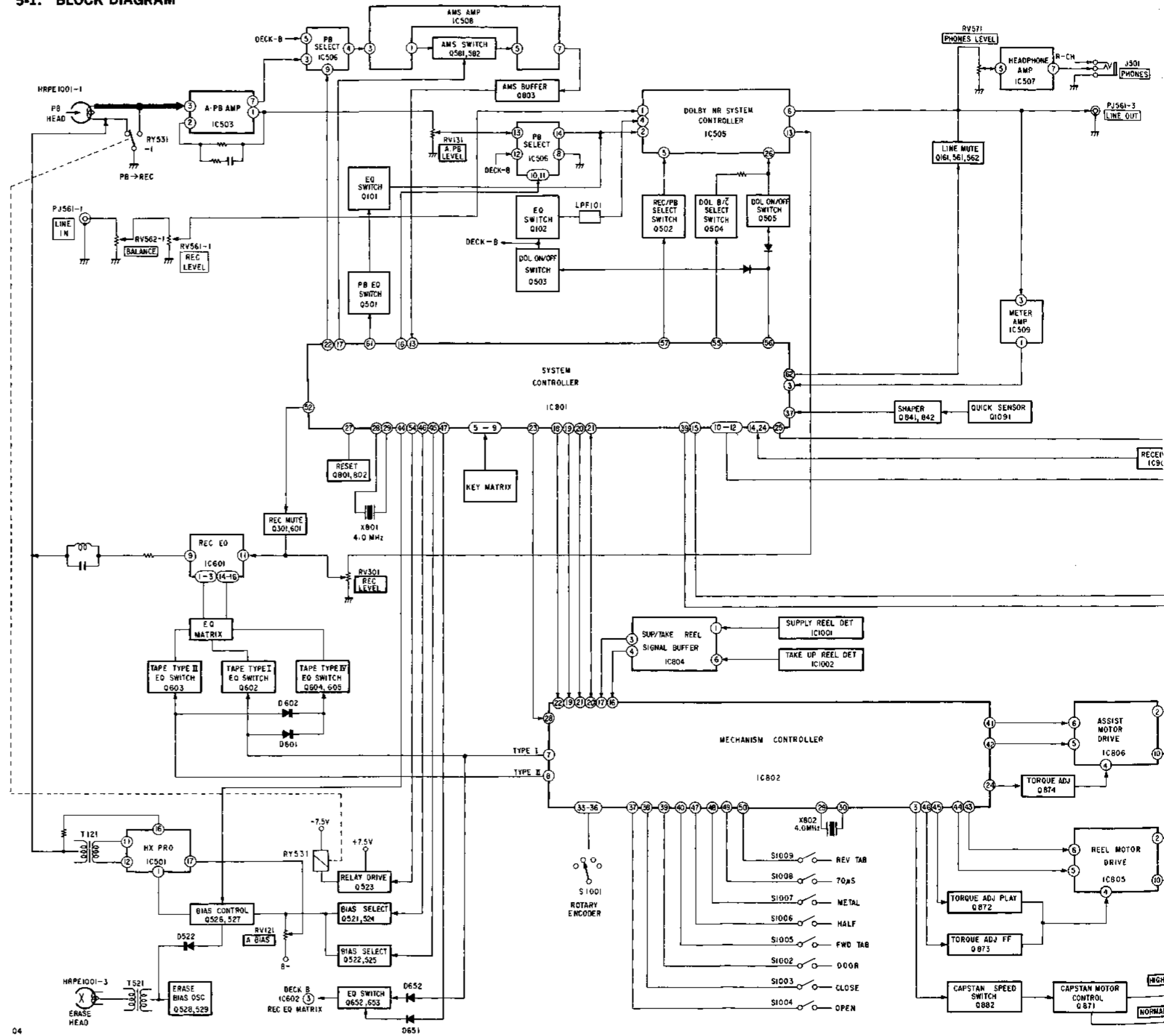

04

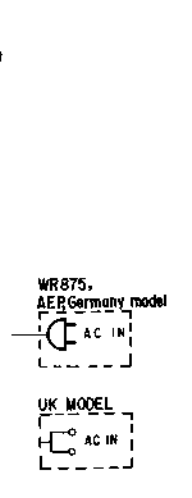
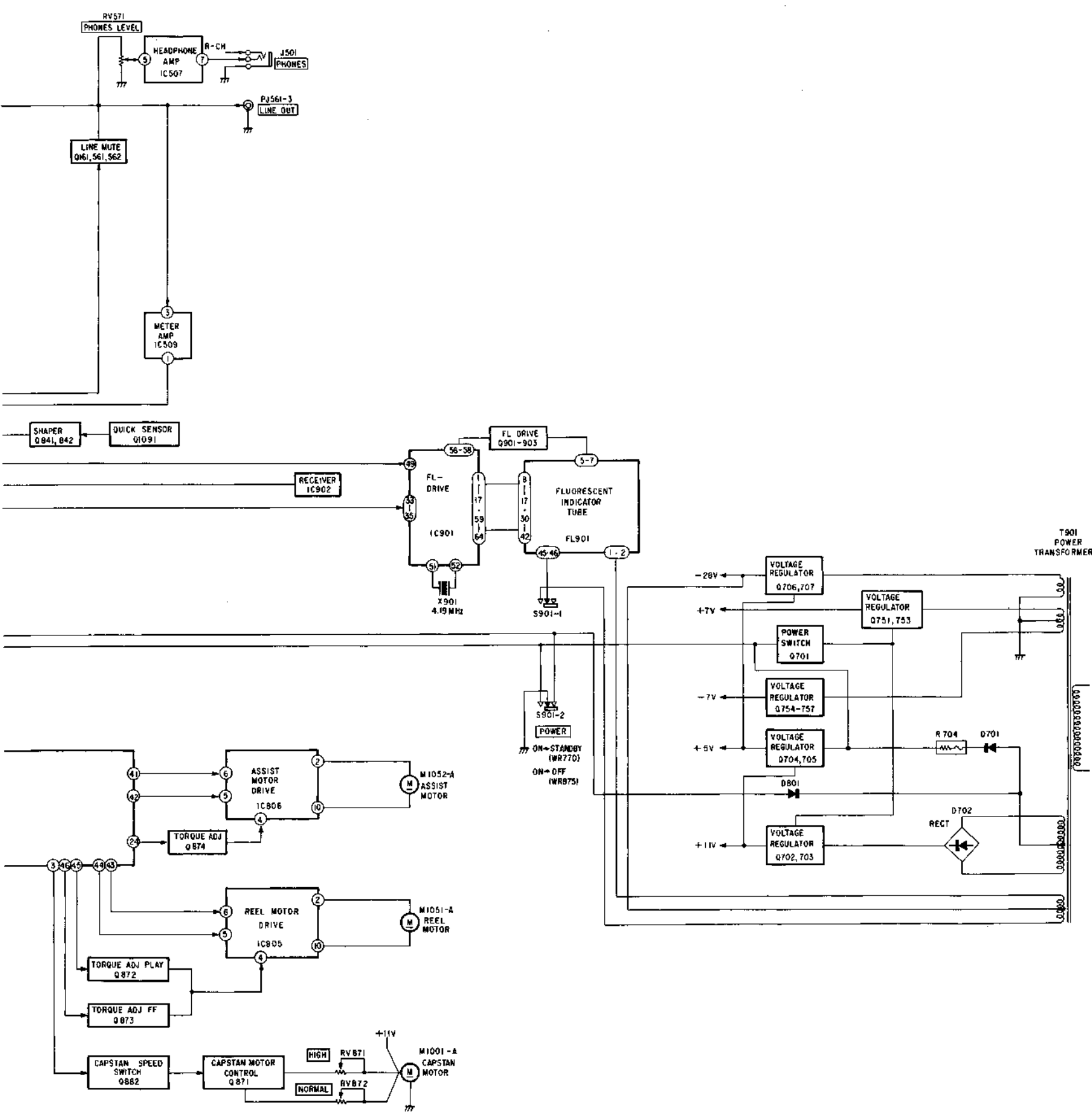

5-2. CIRCUIT BOARDS LOCATION

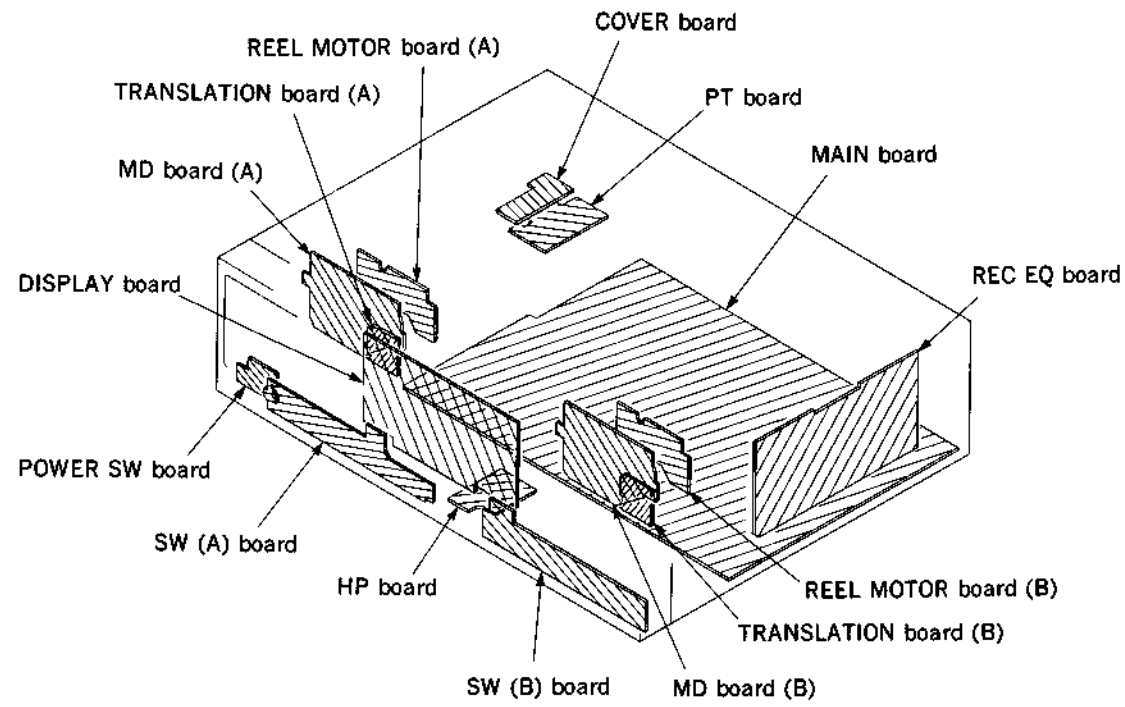

5-3. SEMICONDUCTOR LEAD LAYOUTS

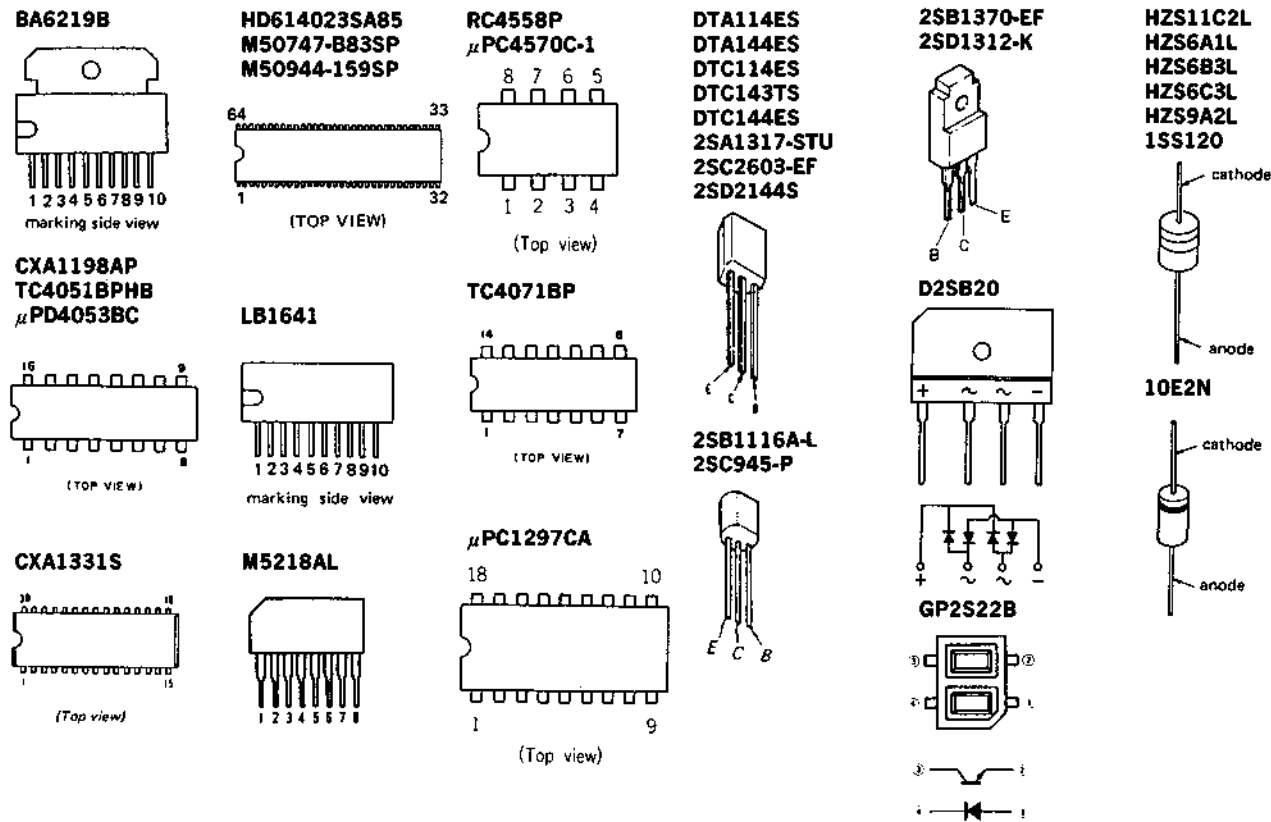

5-4. PRINTED WIRING BOARDS —DISPL

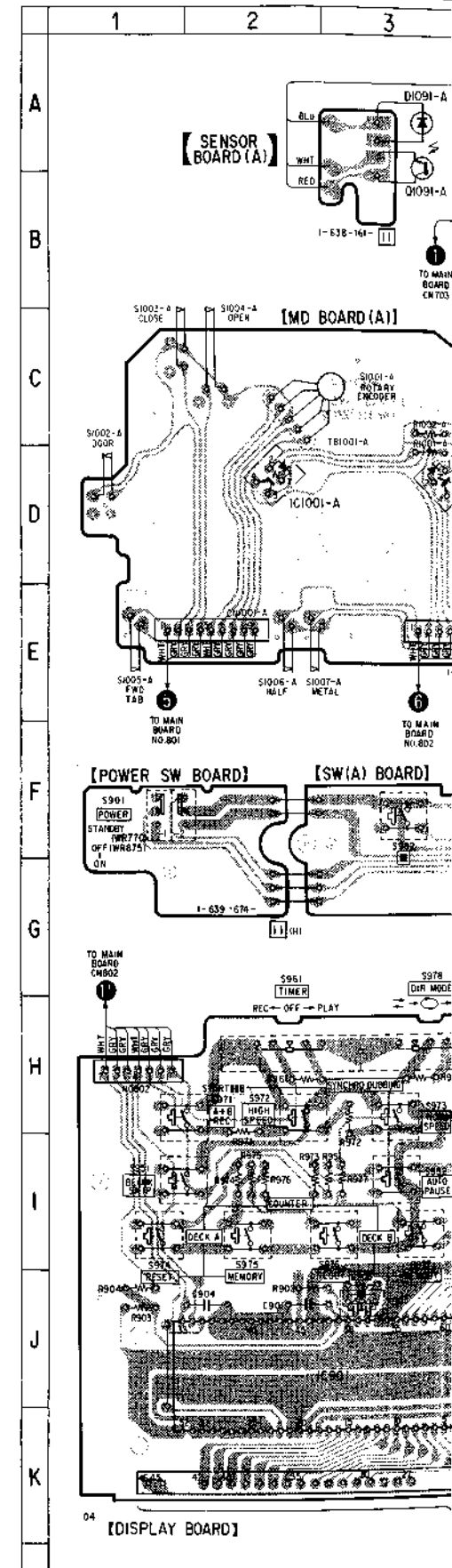

WIRING BOARDS — DISPLAY/DECK/SW SECTION—

2 3 4 5 6 7 8 9 10 11 12 13 14 15 16 17

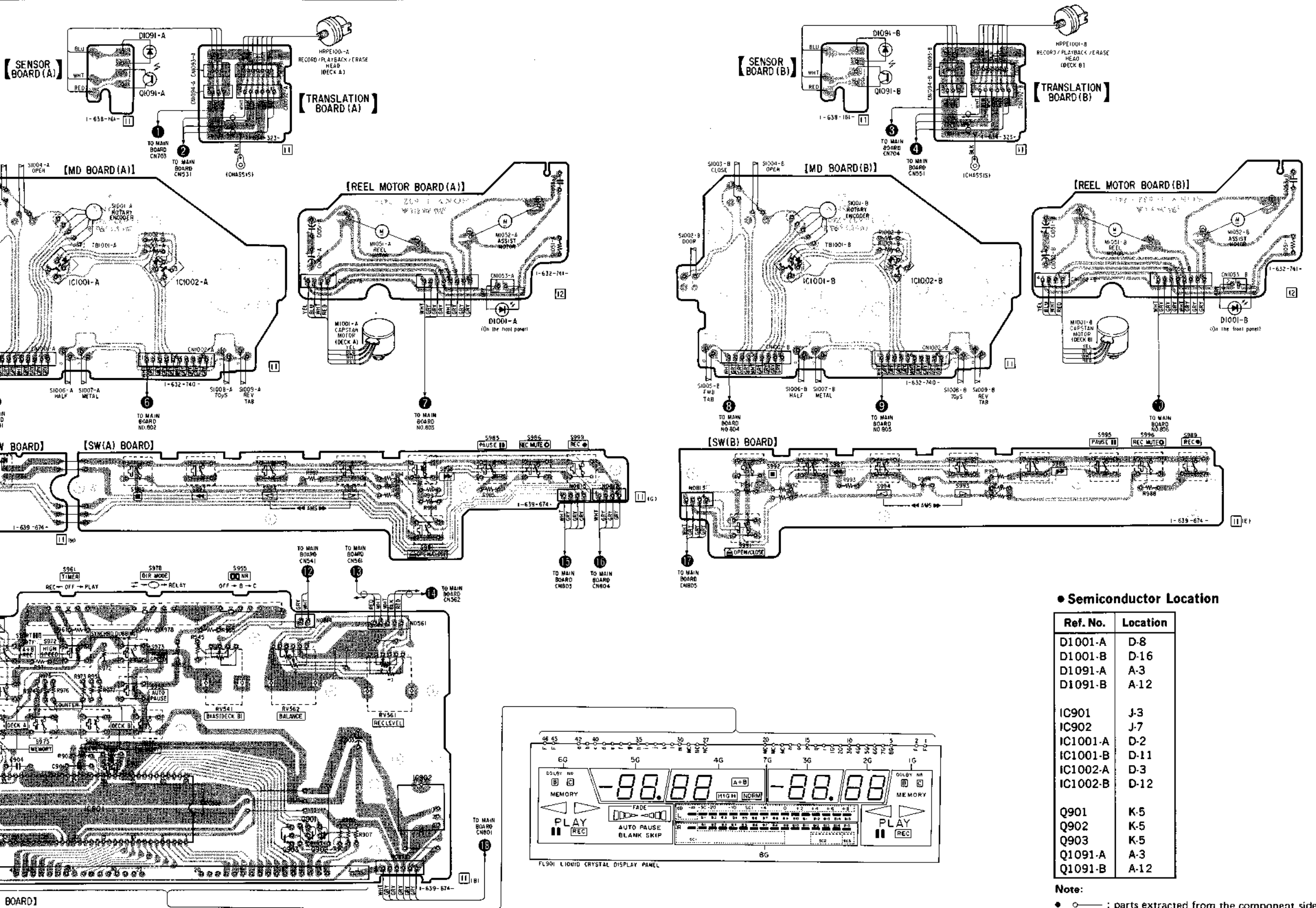

• Semiconductor Location

Ref. No.	Location
D1001-A	D-8
D1001-B	D-16
D1091-A	A-3
D1091-B	A-12
IC901	J-3
IC902	J-7
IC1001-A	D-2
IC1001-B	D-11
IC1002-A	D-3
IC1002-B	D-12
Q901	K-5
Q902	K-5
Q903	K-5
Q1091-A	A-3
Q1091-B	A-12

Note:

- ○ — : parts extracted from the component side.
- — : parts extracted from the conductor side.

5-5. SCHEMATIC DIAGRAM — SYSTEM CONTROL/DISPLAY/DECK/SW SECTION —

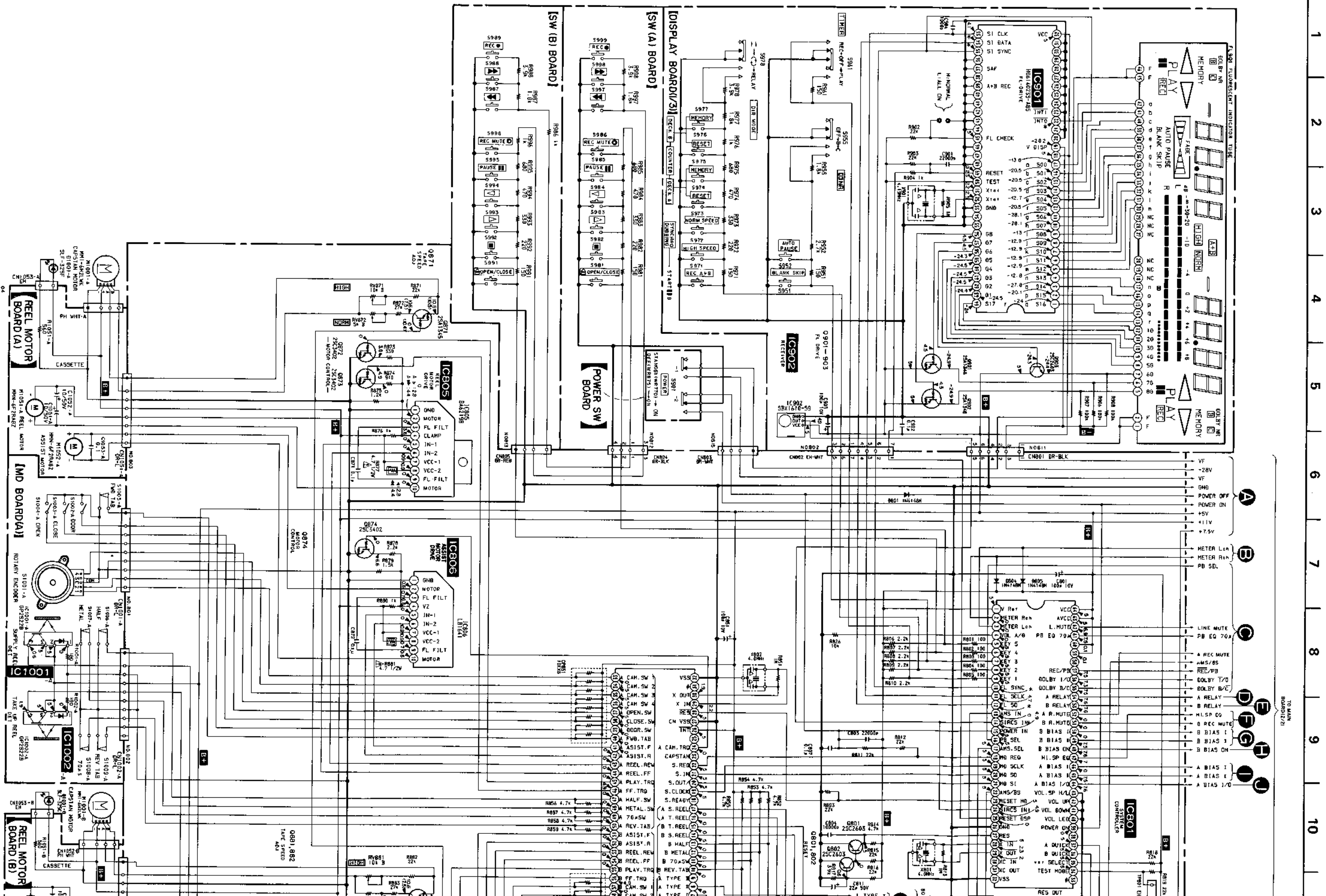

1 2 3 4 5 6 7 8 9 10

A B C D E F G H I J K L M N O

TO MAIN BOARD(12/2)

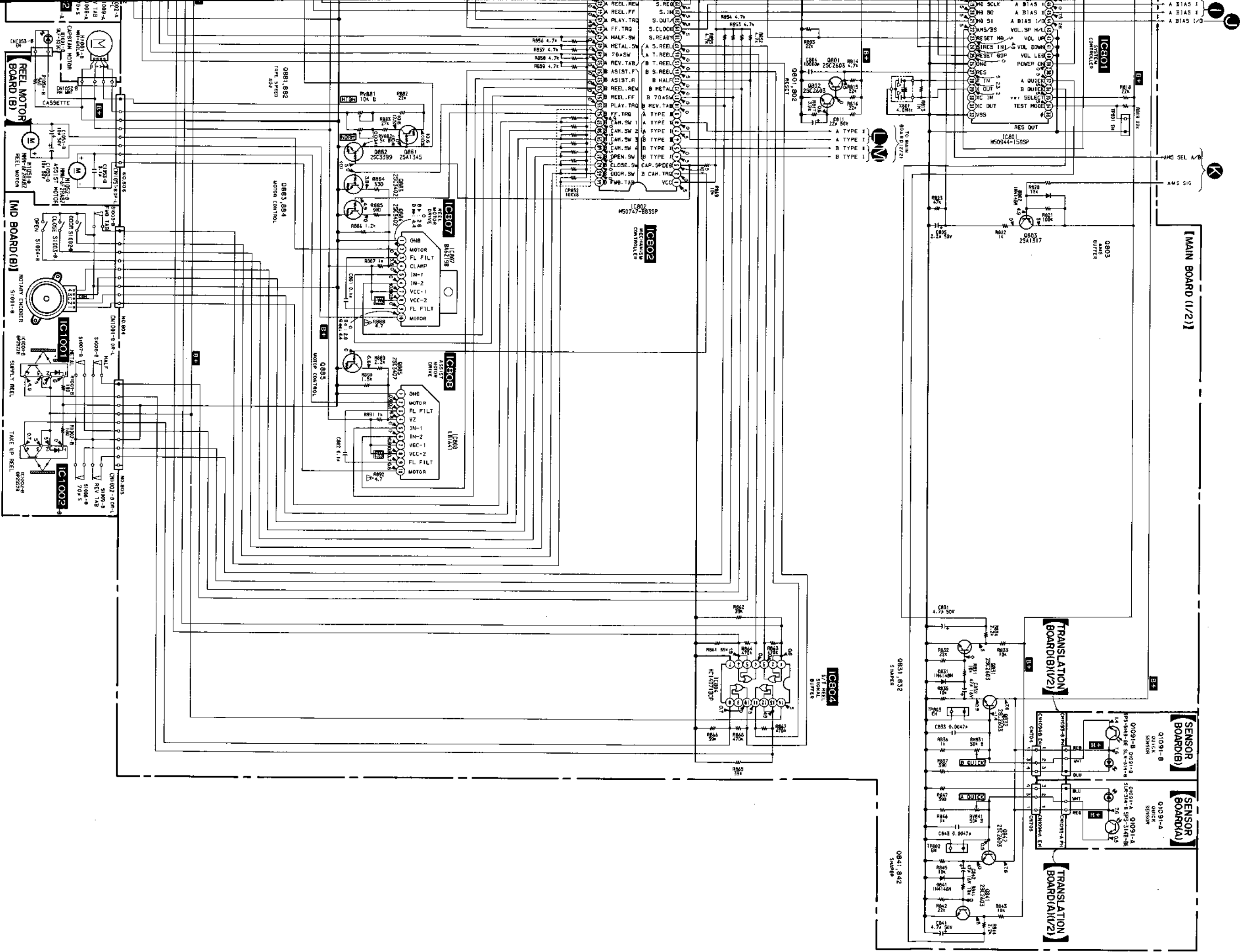

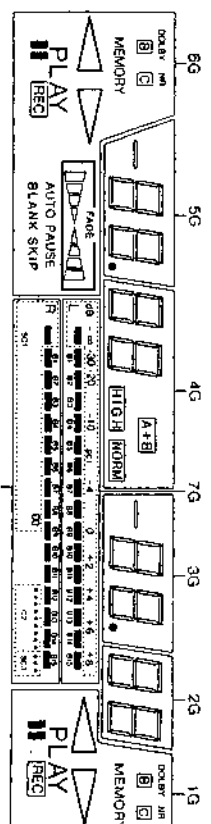
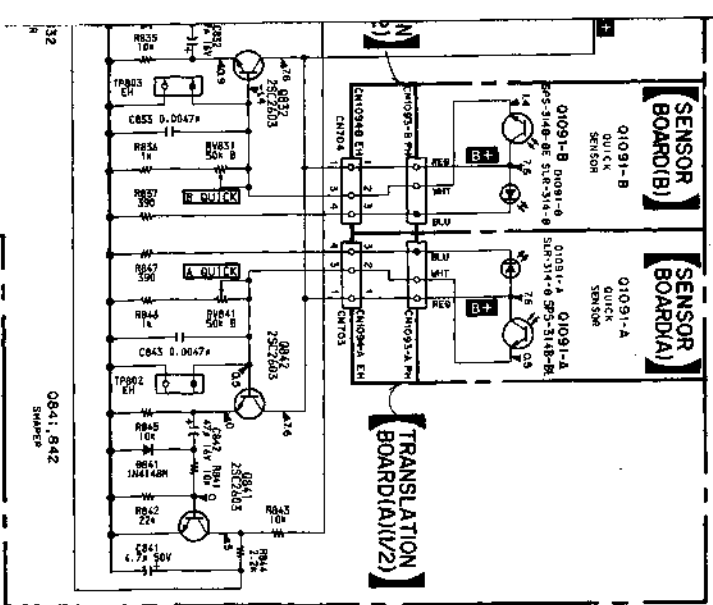

● FL901 Internal Connection

ANODE CONNECTION

a	8G	7G	8G	5G	4G	3G	2G	1G
SC1	SC1	DOLBY NR	a	a	a	a	a	DOLBY NR
(B1)	(B1)	(B)	b	b	b	b	b	(B)
(B4)	(B4)	△	c	c	c	c	c	△
(B6)	(B6)	PLAY	d	d	d	d	d	PLAY
(B5)	(B5)	△	e	e	e	e	e	△
(B2)	(B2)	(C)	f	f	f	f	f	(C)
(B3)	(B3)	MEMORY	g	g	g	g	g	MEMORY
(B7)	(B7)	(I)	h	h	h	h	h	(I)
(B8)	(B8)	(REC)	i	i	i	i	i	(REC)
(B9)	(B9)	(FAD)	j	j	j	j	j	(FAD)
(B12)	(B12)	(H)	k	k	k	k	k	(H)
(B14)	(B14)	(B14) BLANK SKIP	l	l	l	l	l	(B14)
(B13)	(B13)	(B13) AUTO PAUSE	m	m	m	m	m	(B13)
(B10)	(B10)	(B)	n	n	n	n	n	(B)
(B11)	(B11)	(B)	o	o	o	o	o	(B)
(B5)	(B5)	(B15)	p	o	o	o	o	(B15)
SC3	SC3	(DP)	q	o	o	o	o	(DP)
SC2	SC2	(HIG)	r	o	o	o	o	(HIG)
		(NORM)	s	o	o	o	o	(NORM)

● IC Block Diagram
IC805, 807 BA6219B
IC803, 806, 808 LB1641

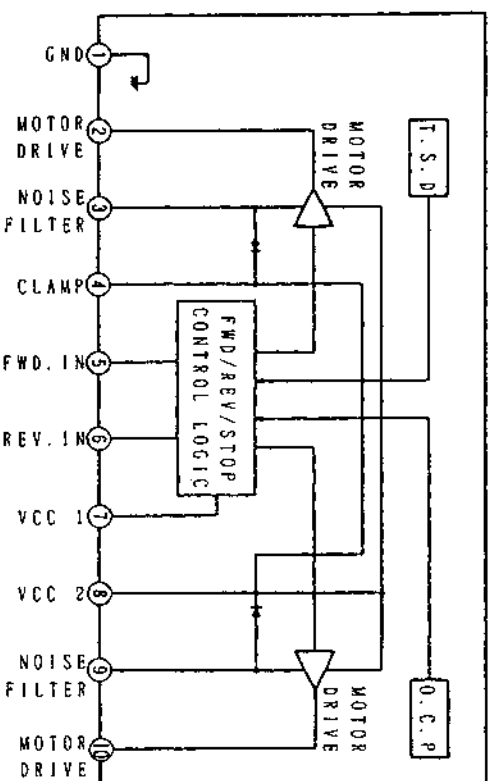

- Note:**
- All capacitors are in μF unless otherwise noted. pF: pF, μF : μF , 50WV or less are not indicated except for electrolytics and tantalums.
 - All resistors are in Ω and $\frac{1}{4}\text{W}$ or less unless otherwise specified.
 - \triangle : internal component.
 - \square : nonflammable resistor.
- Notes:** The components identified by mark \triangle or dotted line with mark \triangle are critical for safety. Replace only with part number specified.
- \square : adjustment for repair.
 - Voltage is dc with respect to ground under no-signal conditions. no mark: POWER ON
 - < : HIGH SPEED DUBBING
 - * : Impossible to measure the voltage at the marked points.
 - Voltages are taken with a VOM (Input Impedance 10M Ω). Voltage variations may be noted due to normal production tolerances.

5-6. SCHEMATIC DIAGRAM — AUDIO/POWER SECTION —

1 2 3 4 5 6

[MAIN BOARD (2/2)]

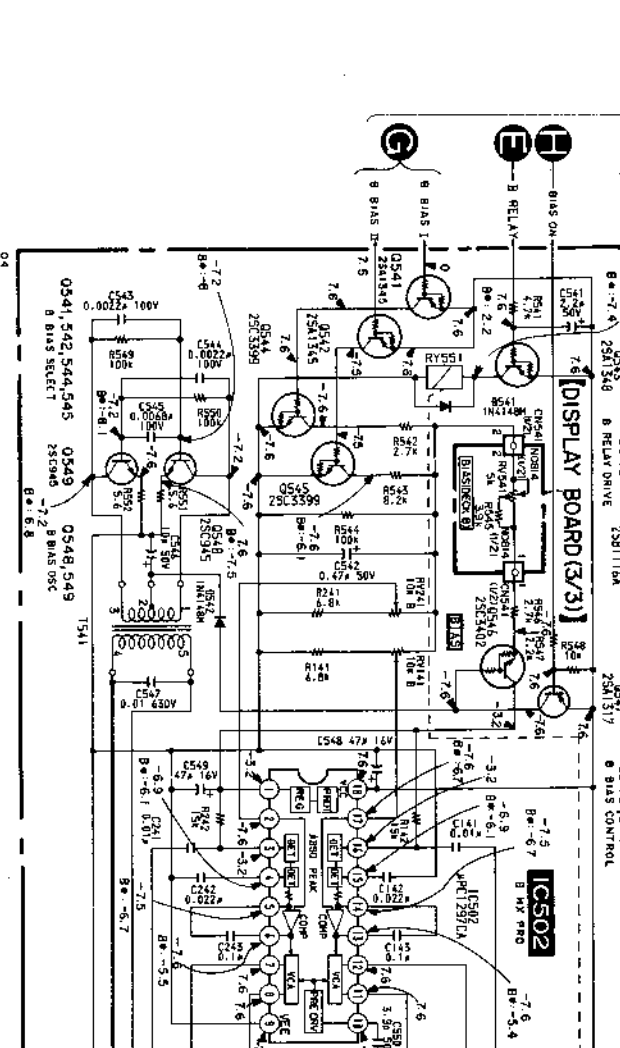
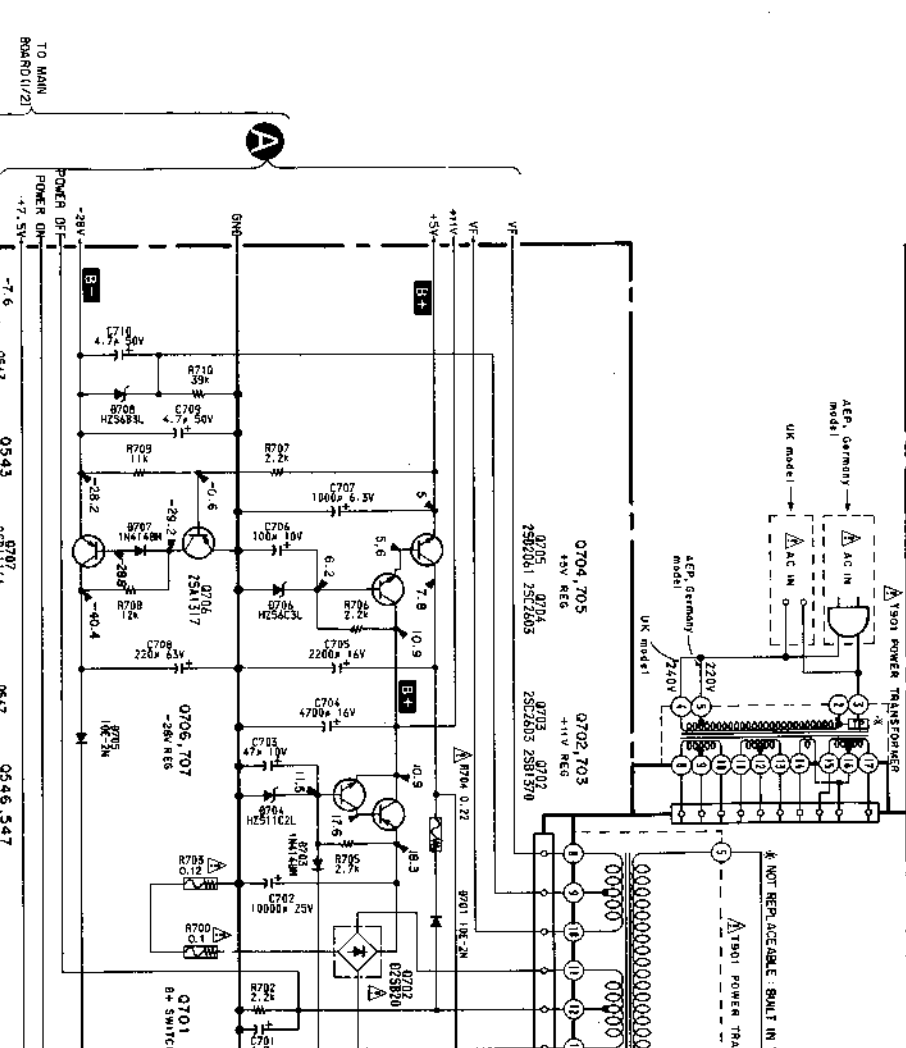
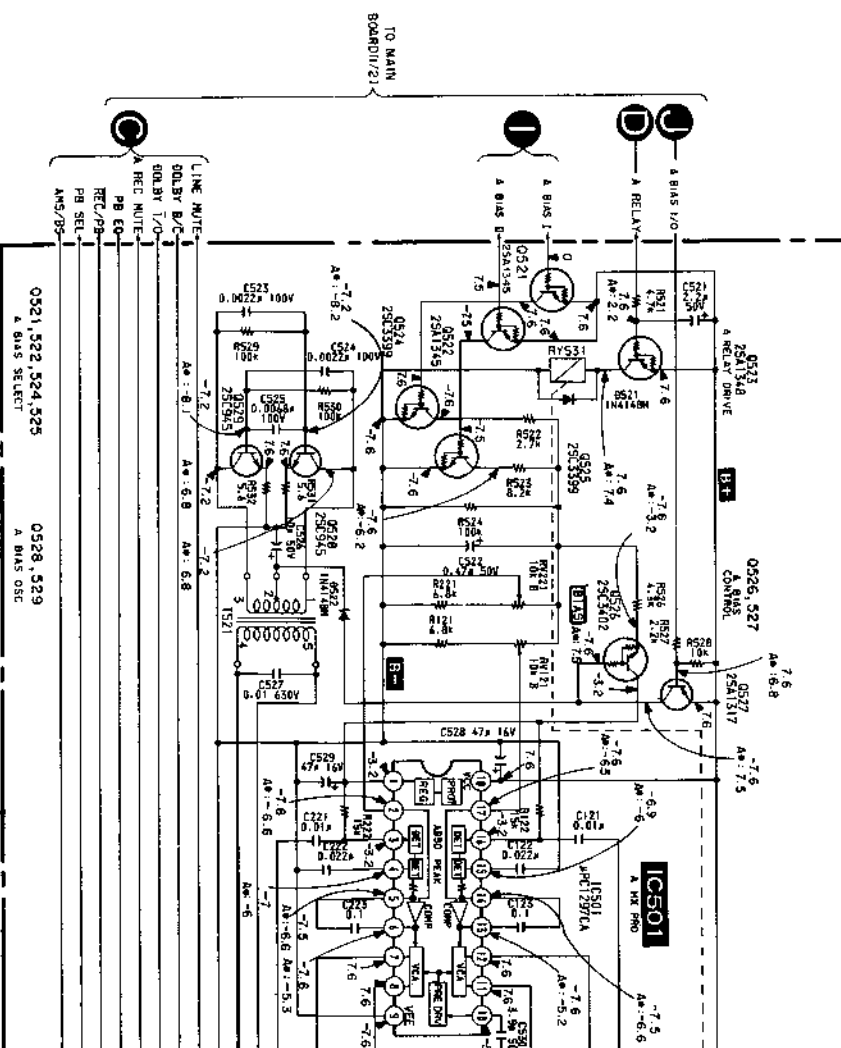

- All capacitors are in μF unless otherwise noted. pF: pμF 50WV or less are not indicated except for electrolytics and tantalums.
- All resistors are in Ω and 1/4 W or less unless otherwise specified.
- : fusible resistor.

Note: The components identified by mark or dotted line with mark are critical for safety. Replace only with part number specified.

- : adjustment for repair.
- Voltage is dc with respect to ground under no-signal conditions. no mark: POWER ON
- < > : HIGH SPEED DUBBING
- * : Impossible to measure the voltage at the marked points.

- ▷ : FWD ◁ : REV
- ⇨ : FF ⇩ : REW
- Voltages are taken with a VOM (Input Impedance 10M Ω). Voltage variations may be noted due to normal production tolerances.
- Signal path.
- ▷▷ : PB (DECK A)
- ⇨⇨ : REC (DECK A)
- ◁◁ : PB (DECK B)
- ⇩⇩ : REC (DECK B)

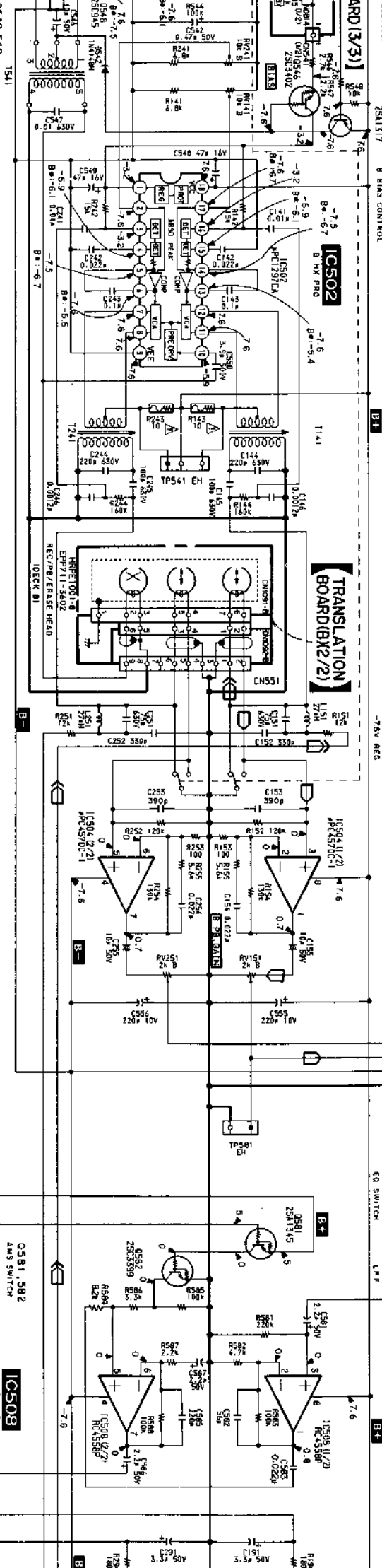
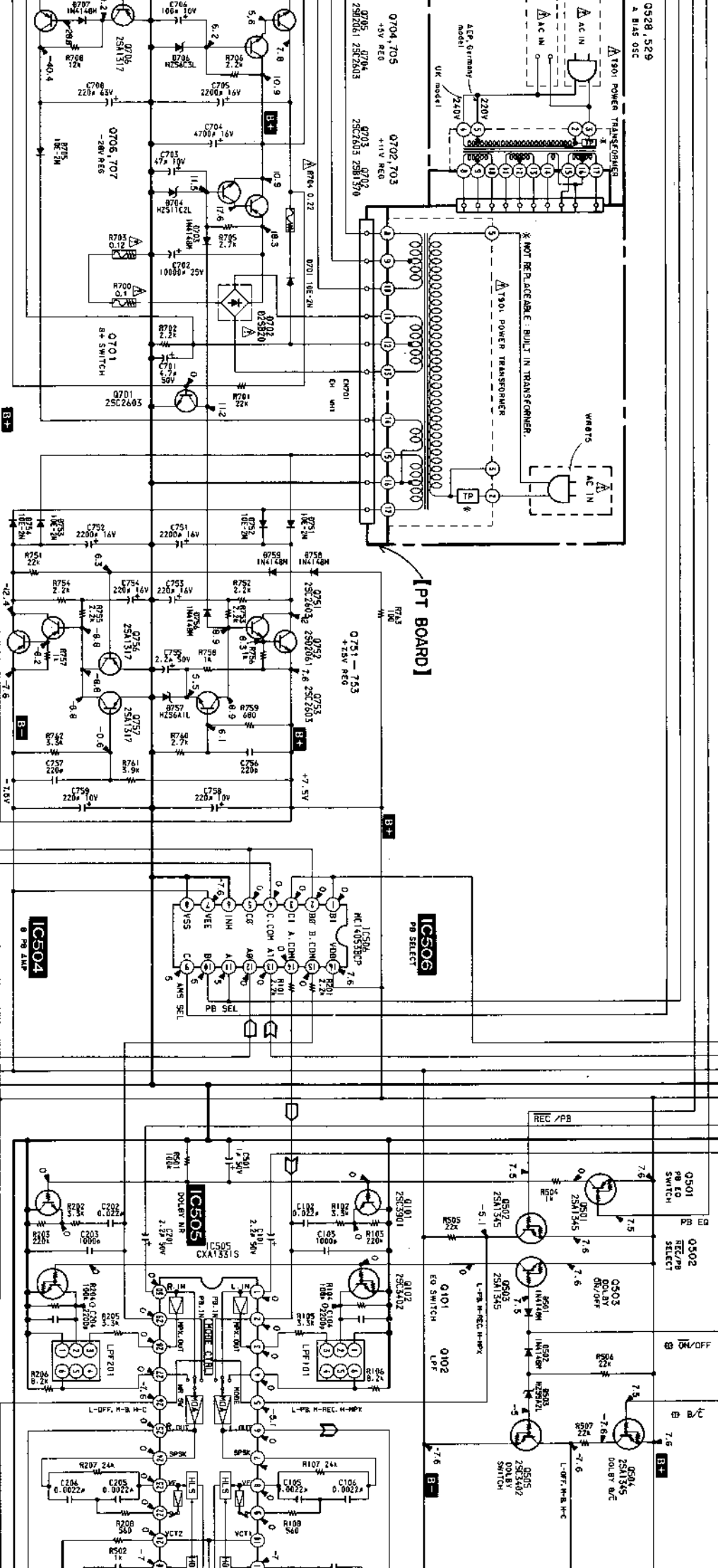
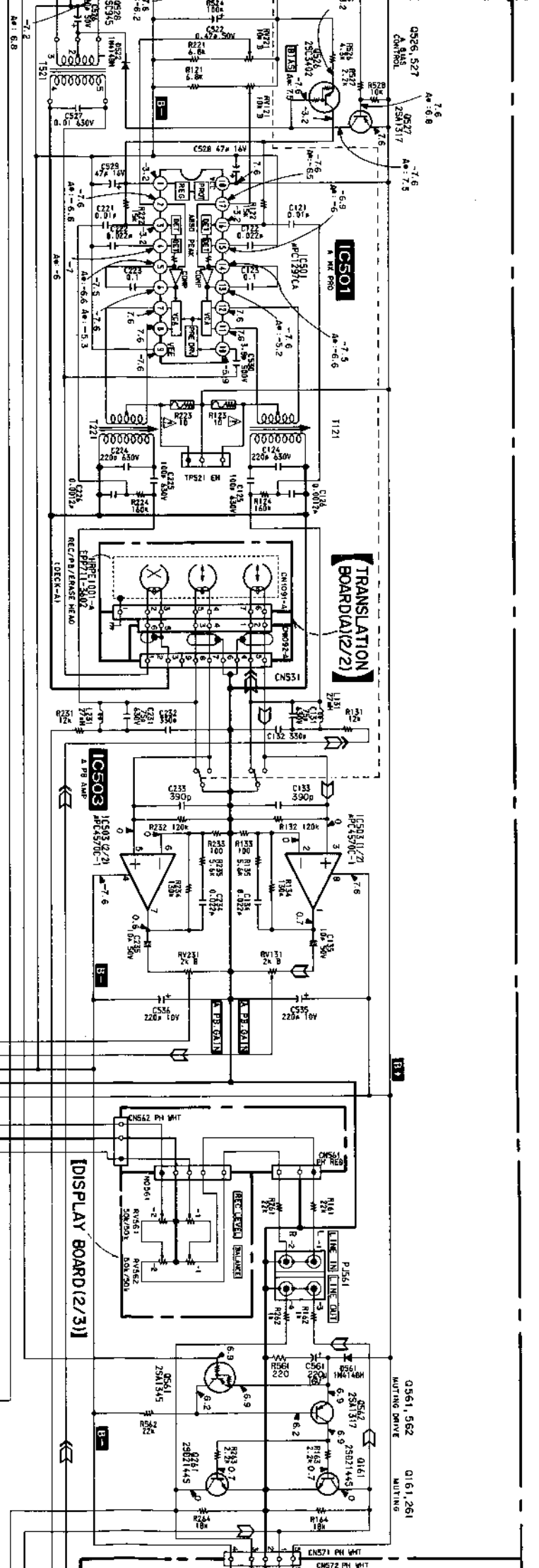

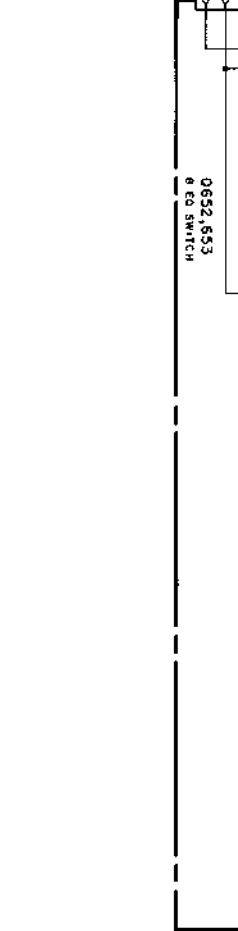
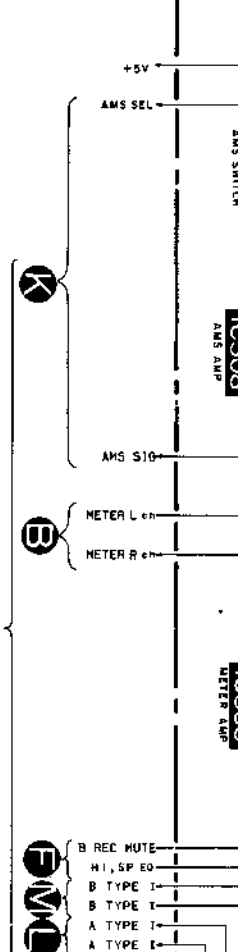
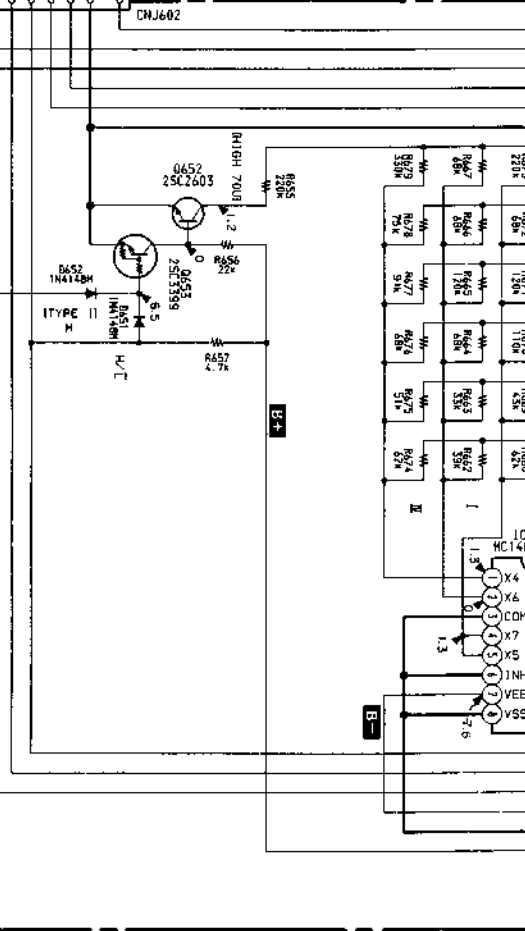
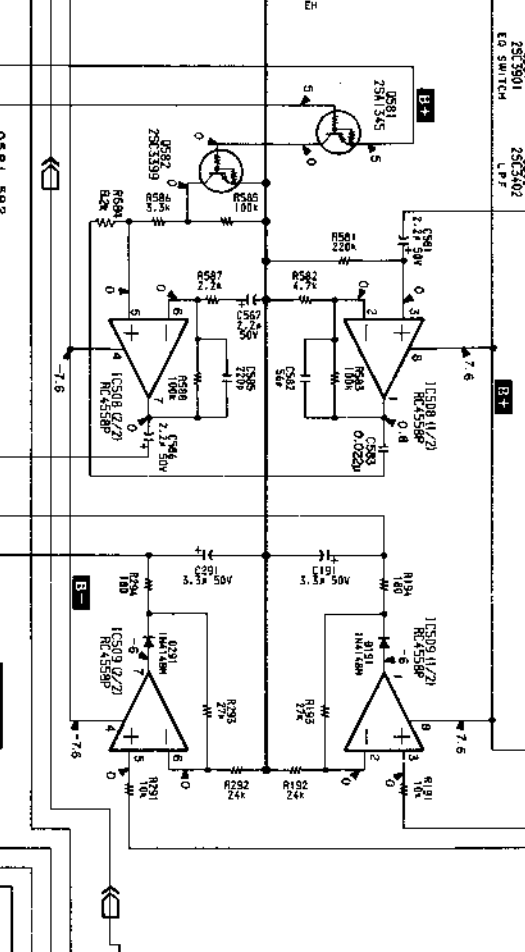
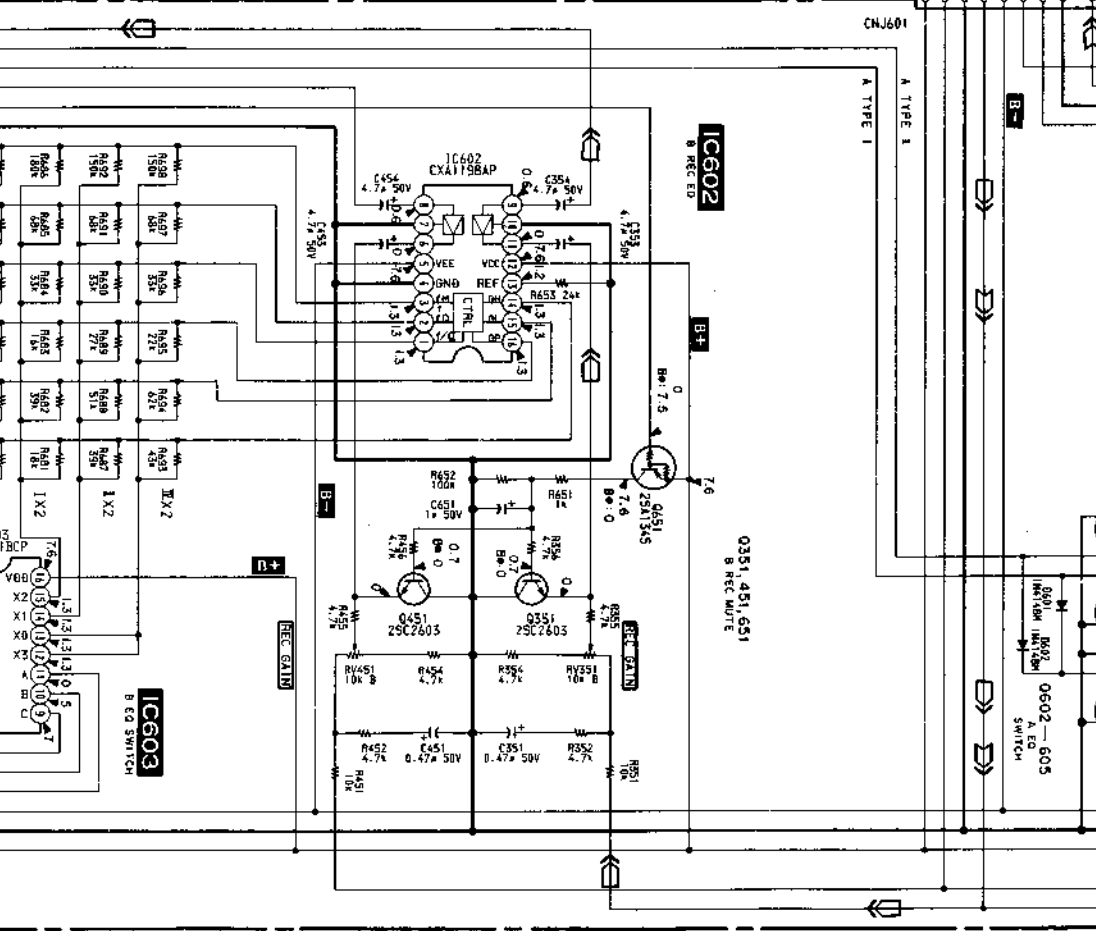
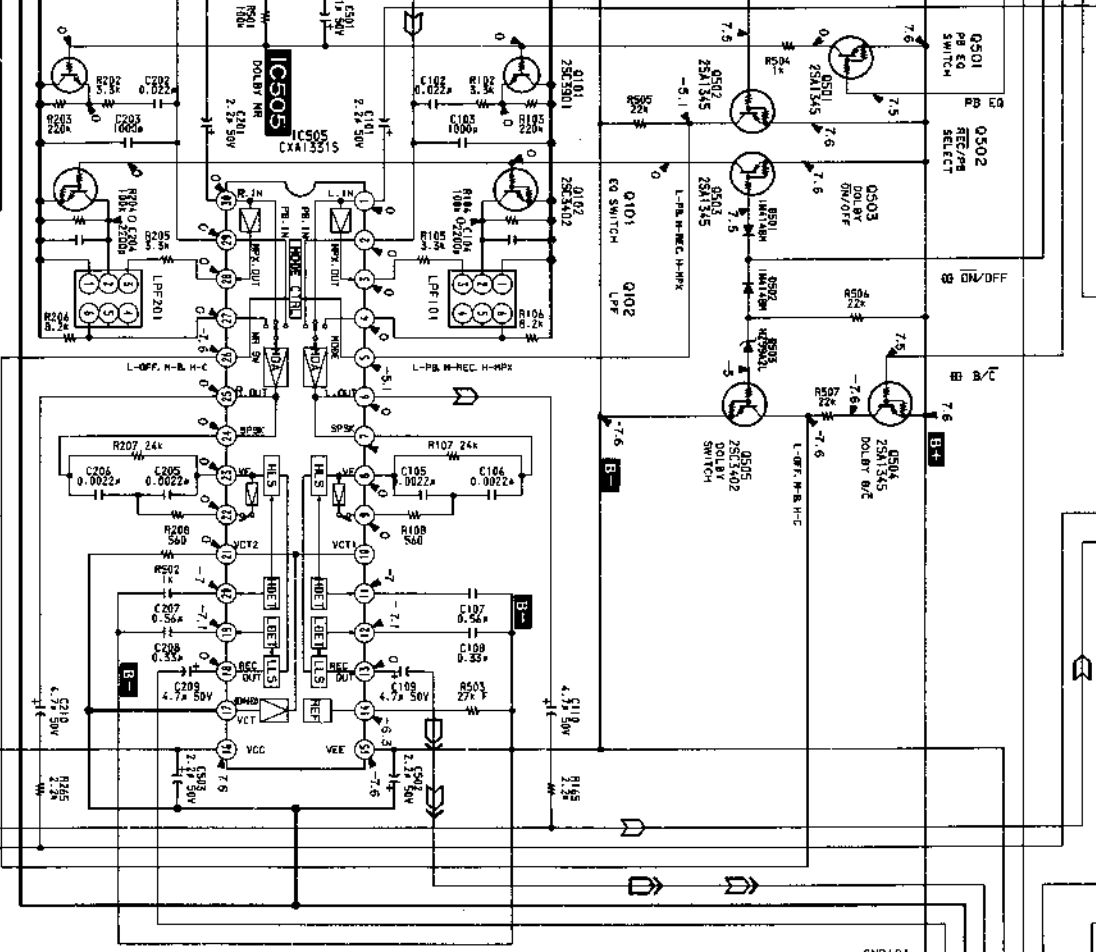
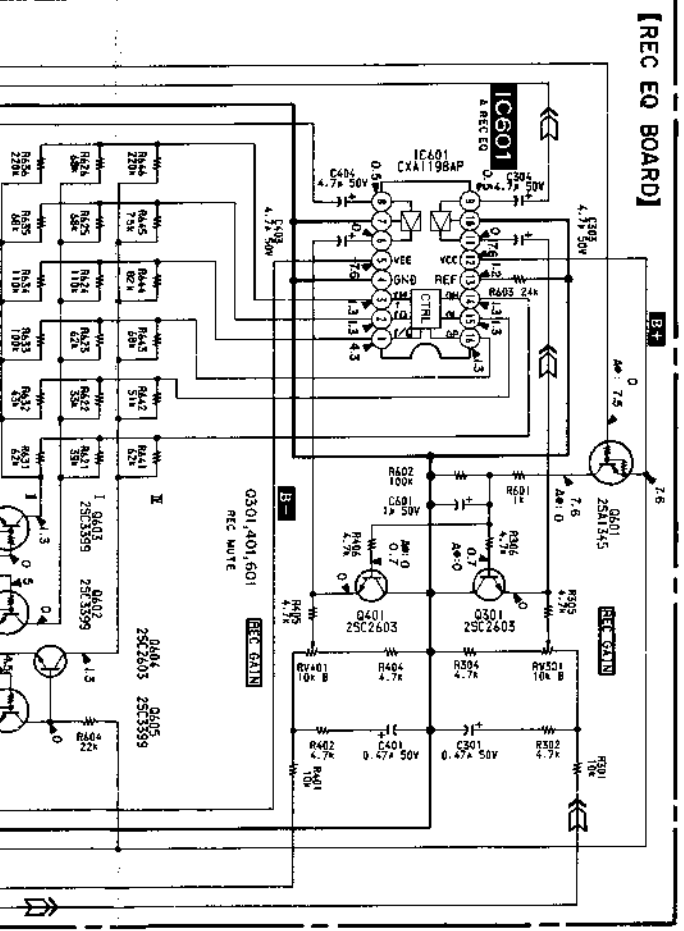
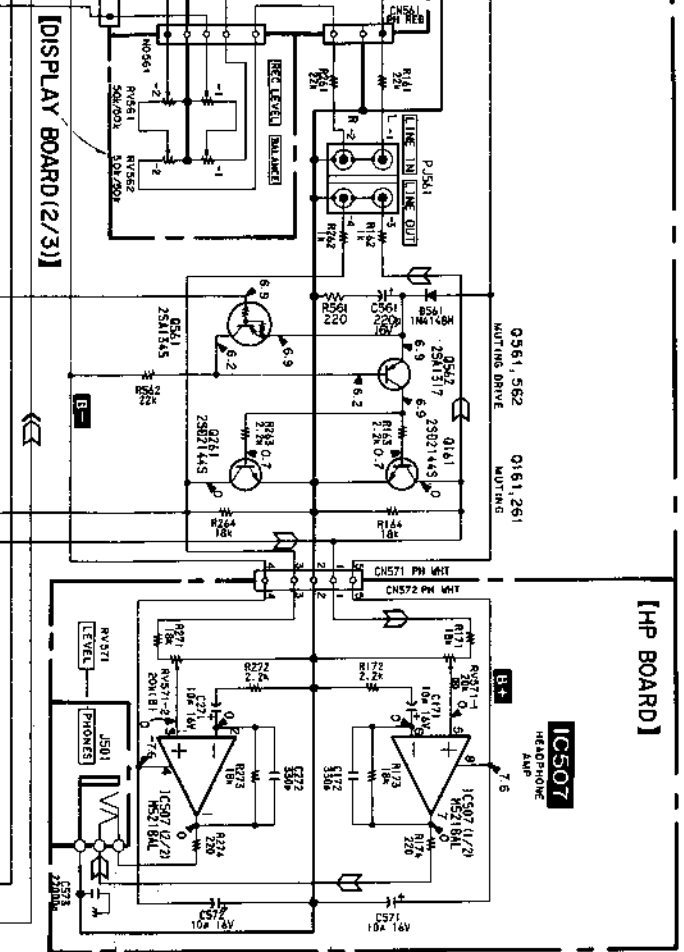

5-7. PRINTED WIRING BOARDS —AUDIO/SYSTEM CONTROL/POWER SECTION

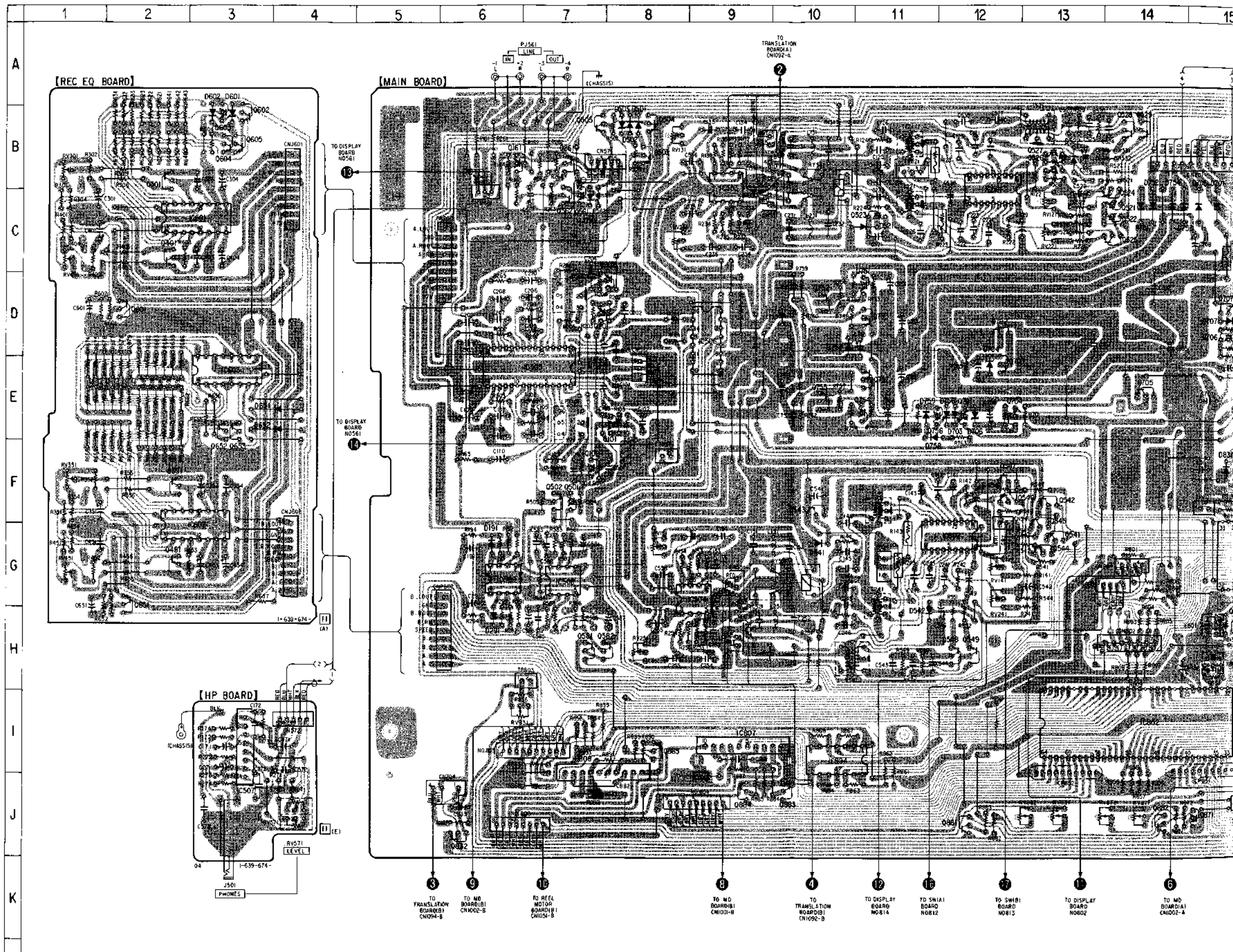

12 13 14 15 16 17 18 19 20 21 22

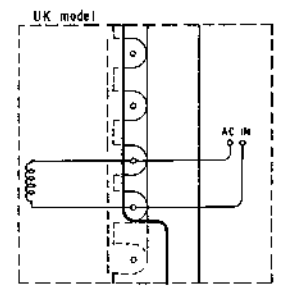
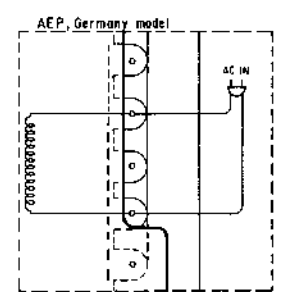
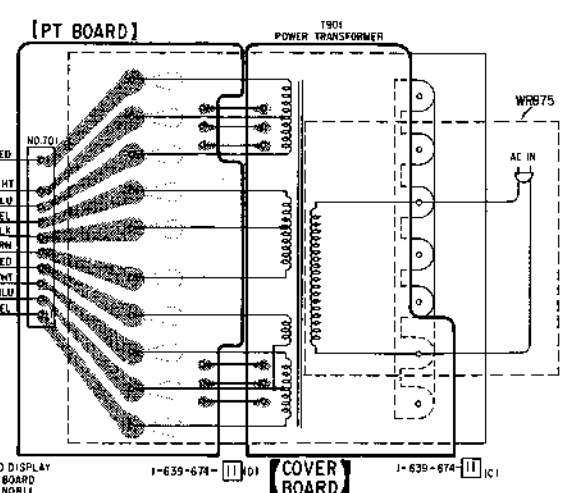
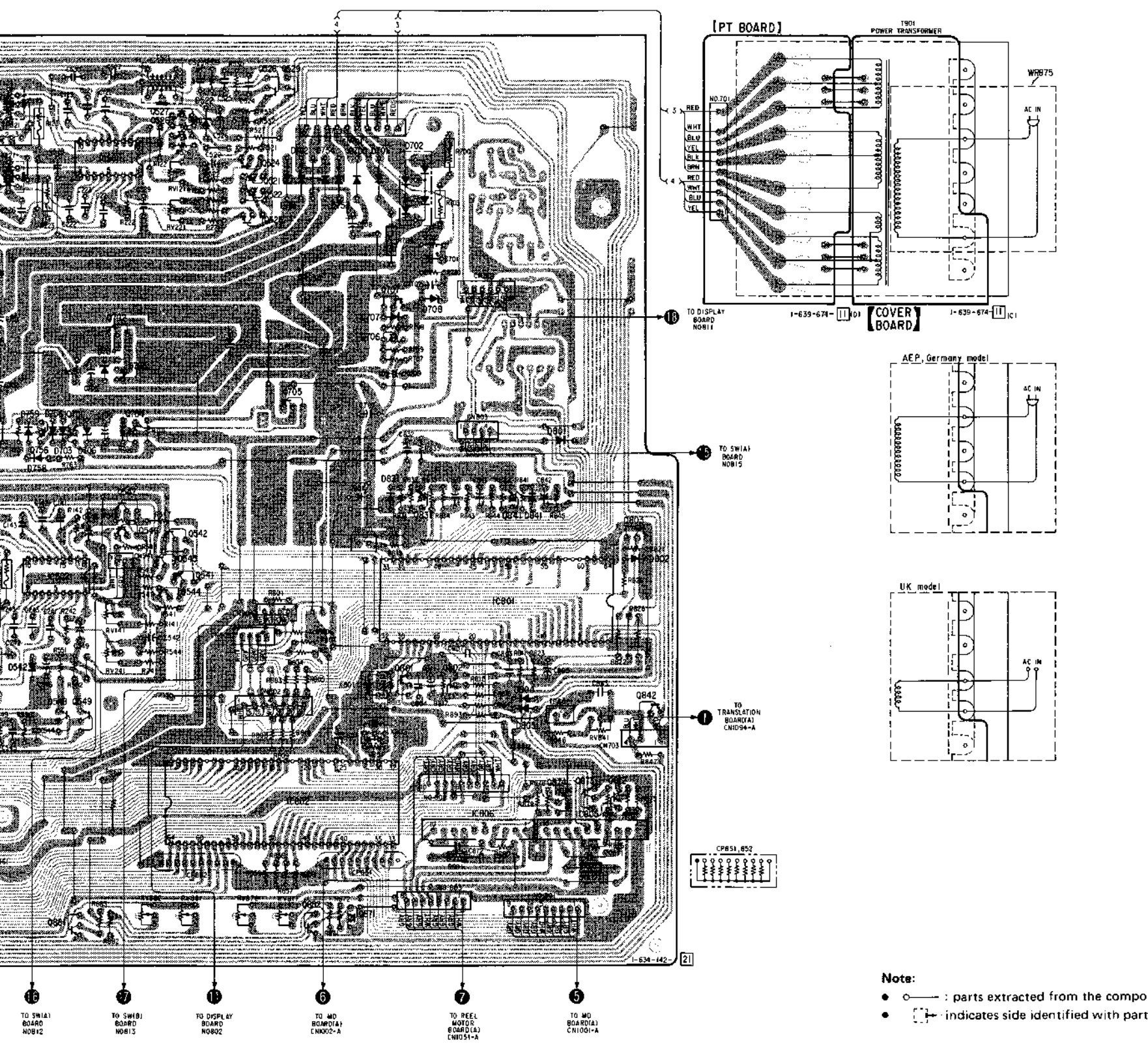

• Semiconductor Location

Ref. No.	Location	Ref. No.	Location
D191	G-6	Q451	G-2
D291	H-6	Q501	F-7
D501	B-8	Q502	F-7
D502	B-8	Q503	B-8
D503	B-8	Q504	B-8
D521	C-11	Q505	B-7
D522	B-13	Q521	C-14
D541	G-10	Q522	C-14
D542	H-11	Q523	C-11
D561	C-7	Q524	C-14
D601	B-3	Q525	C-14
D602	B-3	Q526	B-13
D651	E-3	Q527	B-13
D652	E-3	Q528	B-14
D701	C-15	Q529	B-14
D702	C-15	Q541	G-13
D703	E-12	Q542	F-13
D704	E-12	Q543	F-10
D705	C-15	Q544	G-13
D706	E-12	Q545	G-13
D707	D-15	Q546	F-12
D708	D-15	Q547	F-12
D751	C-14	Q548	H-12
D752	C-14	Q549	H-12
D753	C-14	Q561	C-7
D754	C-14	Q562	C-7
D756	E-12	Q581	H-7
D757	D-10	Q582	H-7
D758	E-11	Q601	D-2
D759	E-11	Q602	B-3
D801	E-17	Q603	B-3
D802	F-17	Q604	B-3
D804	H-16	Q605	B-3
D805	H-16	Q651	G-2
D831	F-15	Q652	E-3
D841	F-16	Q653	E-3
IC501	B-12	Q701	E-12
IC502	G-12	Q702	D-12
IC503	C-9	Q703	E-12
IC504	G-9	Q704	E-12
IC505	E-7	Q705	E-14
IC506	D-9	Q706	D-15
IC507	I-3	Q707	D-15
IC508	G-7	Q751	D-11
IC509	G-6	Q752	D-10
IC601	C-3	Q753	D-11
IC602	G-3	Q754	E-11
IC603	E-3	Q755	E-10
IC801	G-16	Q756	E-11
IC802	I-14	Q757	E-11
IC804	I-10	Q801	H-15
IC805	I-17	Q802	H-16
IC806	I-16	Q803	F-17
IC807	I-9	Q831	F-15
IC808	I-7	Q832	J-6
Q101	E-8	Q841	F-16
Q102	F-7	Q842	H-18
Q161	B-6	Q871	J-15
Q201	D-7	Q872	I-17
Q202	D-8	Q873	I-17
Q261	B-7	Q874	I-17
Q301	B-2	Q881	J-12
Q351	F-2	Q882	J-14
Q401	C-2	Q883	J-10
		Q884	J-9
		Q885	I-8

Notes:
 • ○ : parts extracted from the component side.
 • □ : indicates side identified with part number.

**SECTION 6
EXPLODED VIEWS**

NOTE:

- The mechanical parts with no reference number in the exploded views are not supplied.
- Items marked "*" are not stocked since they are seldom required for routine service. Some delay should be anticipated when ordering these items.

- -XX, -X mean standardized parts, so they may have some differences from the original one.
- Color Indication of Appearance Parts
Example:
KNOB, BALANCE (WHITE)...(RED)
Parts Color Cabinet's Color

- Hardware(# mark) list is given in the last of this parts list.

The components identified by mark ▲ or dotted line with mark ▲ are critical for safety. Replace only with part number specified.

6-1. CHASSIS SECTION

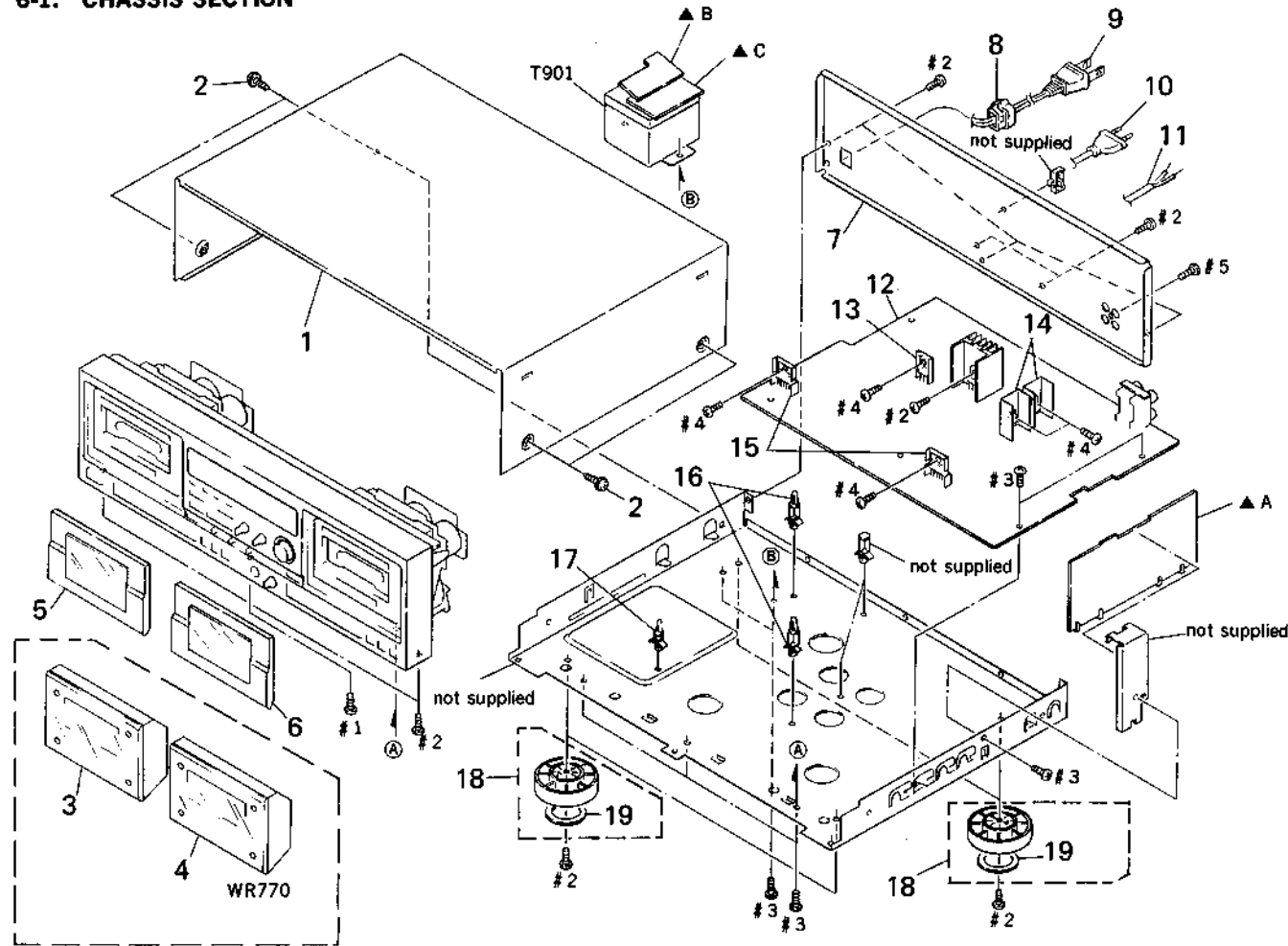

Ref.No.	Part No.	Description	Remark	Ref.No.	Part No.	Description	Remark
1	4-925-039-61	CASE		12	* A-2006-392-A	MAIN BOARD, COMPLETE	
2	3-704-366-01	SCREW (CASE) (M3X8)		13	* 3-309-144-21	HEAT SINK	
3	X-3363-200-1	LID (A) ASSY, CASSETTE (WR770)		14	* 4-880-403-11	HEAT SINK	
4	X-3363-201-1	LID (B) ASSY, CASSETTE (WR770)		15	* 3-356-925-01	HEAT SINK	
5	X-3362-492-1	LID (A) ASSY, CASSETTE (WR875)		16	* 3-346-265-11	HOLDER, PC BOARD	
6	X-3362-493-1	LID (B) ASSY, CASSETTE (WR875)		17	* 4-924-098-11	HOLDER, PC BOARD	
7	* 3-365-369-01	PANEL, BACK (US)		18	X-3304-938-2	FOOT ASSY (WR770)	
7	* 3-365-369-11	PANEL, BACK (AEP, Germany)		18	X-4885-950-1	FOOT ASSY (WR875)	
7	* 3-365-369-21	PANEL, BACK (UK)		19	4-923-836-11	CUSHION	
8	* 3-703-244-00	BUSHING (2104), CORD		T901	▲ 1-450-444-11	TRANSFORMER, POWER (WR875)	
9	▲ 1-555-465-00	CORD, POWER (US)		T901	▲ 1-450-446-11	TRANSFORMER, POWER (WR770)	
10	▲ 1-555-795-00	CORD, POWER, EULO PLUG (AEP, Germany)					
11	▲ 1-556-035-00	CORD, POWER (UK)					

6-2. FRONT PANEL SECTION

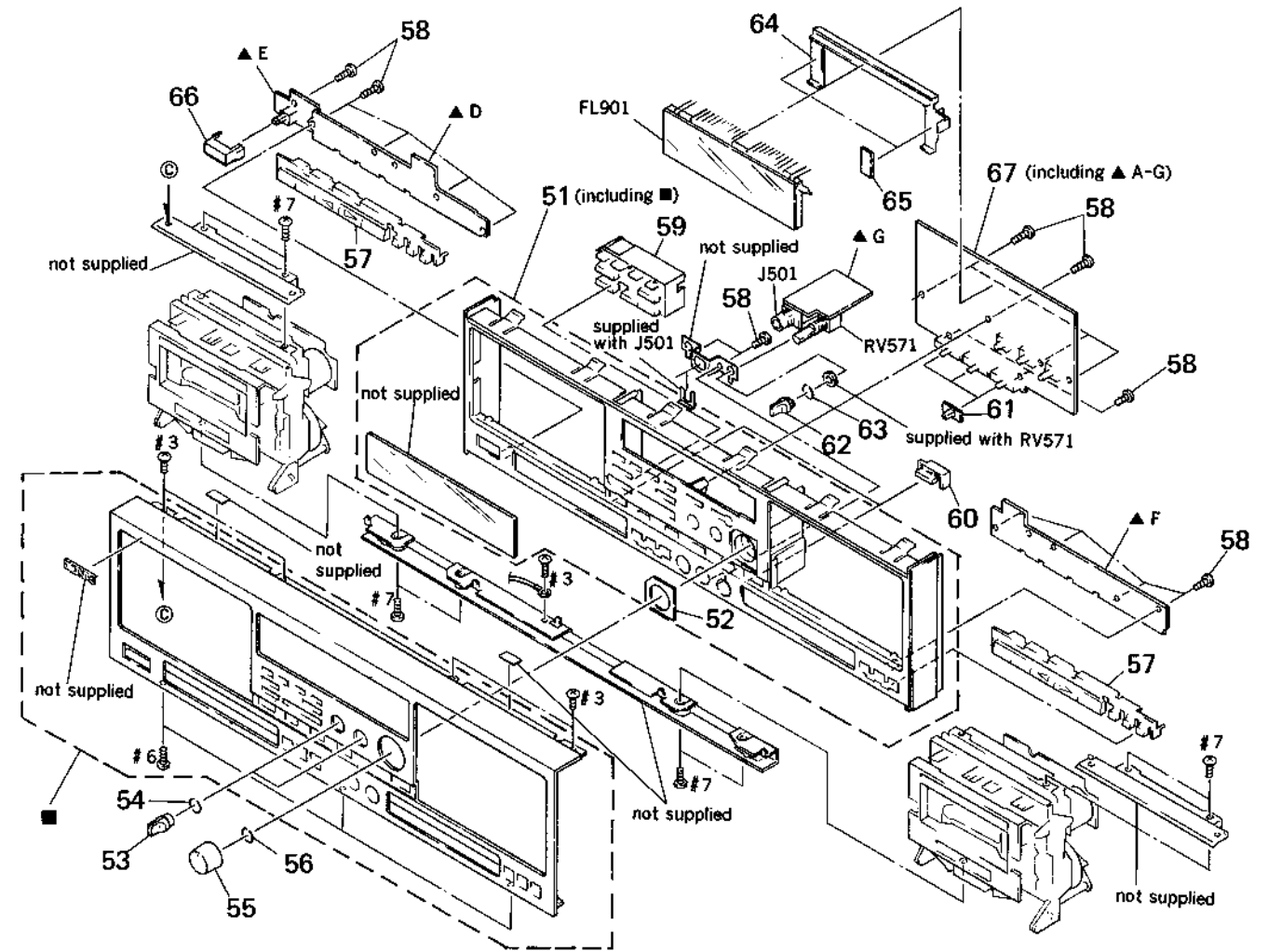

Ref.No.	Part No.	Description	Remark	Ref.No.	Part No.	Description	Remark
51	A-2003-720-A	PANEL ASSY, FRONT (WR875)		60	3-354-930-01	BUTTON (D)	
51	A-2003-721-A	PANEL ASSY, FRONT (WR770)		61	4-922-518-01	KNOB (TIMER)	
52	3-354-923-01	PLATE (VOL), ORNAMENTAL		62	3-354-931-01	KNOB (DIA. 10)	
53	3-354-931-11	KNOB (DIA. 10)		63	3-356-935-01	SPRING	
54	3-354-981-01	SPRING (SUS), RING		64	3-365-420-01	HOLDER, FL TUBE	
55	3-359-932-01	KNOB (REC)		65	9-911-844-11	CUSHION	
56	3-362-235-01	SPRING (REC LEVEL), RING		66	3-354-932-01	BUTTON (POWER)	
57	3-365-419-01	BUTTON (A)		67	* A-2006-393-A	PANEL BOARD, COMPLETE	
58	4-928-635-01	SCREW, +BV (2.6X8) TAPPING		FL901	1-519-594-11	INDICATOR TUBE, FLUORESCENT	
59	3-354-938-21	BUTTON (B)		J501	1-507-796-71	JACK (PHONES)	
				RV571	1-238-085-11	RES, VAR, CARBON 20K/20K (PHONES LEVEL)	

6-3. MECHANISM DECK SECTION 1
(TCM-200R5)

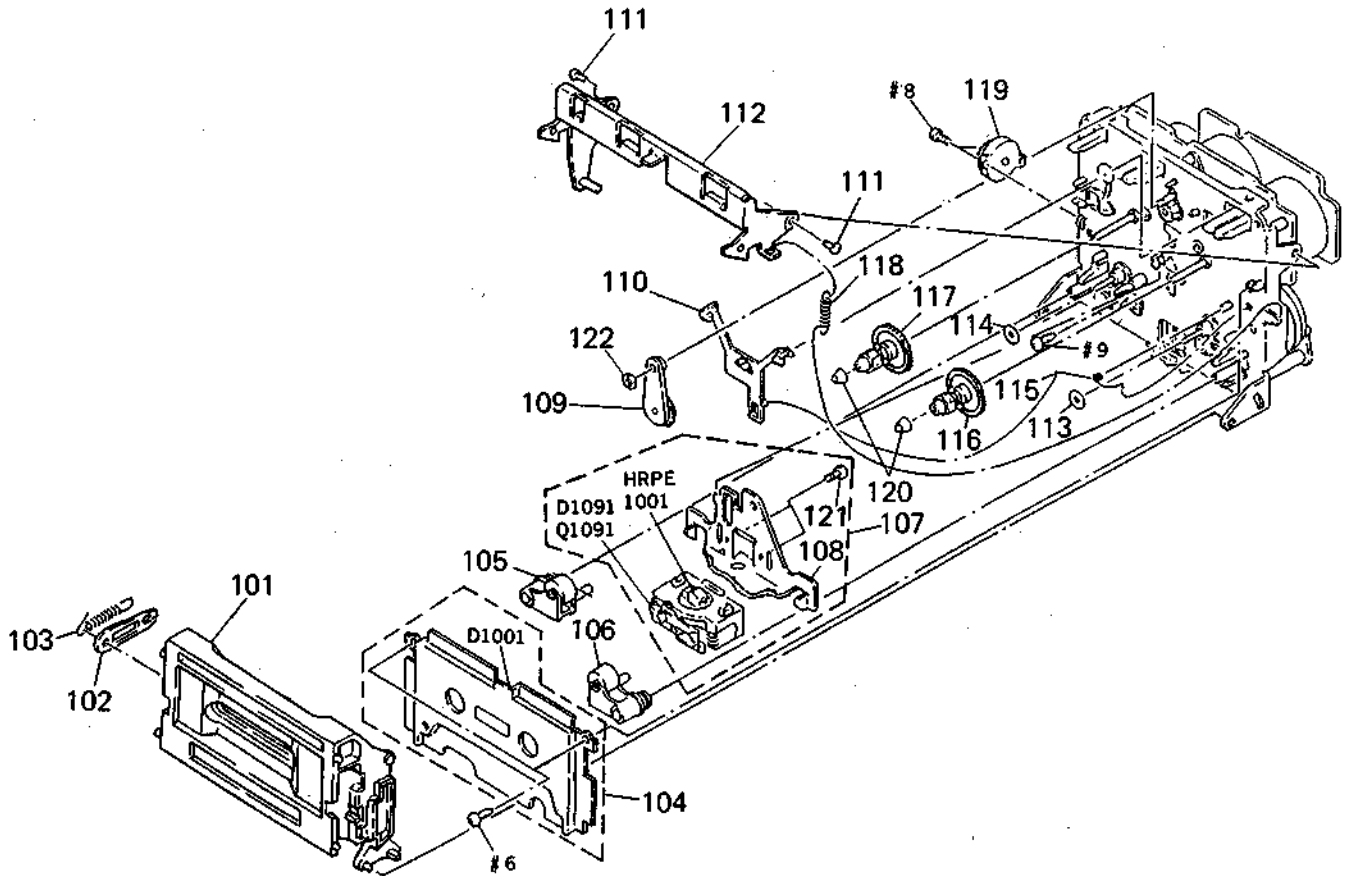

Ref. No.	Part No.	Description	Remark	Ref. No.	Part No.	Description	Remark
101	X-3362-814-1	HOLDER (CD) ASSY, CASSETTE		114	3-356-714-01	WASHER	
102	* 3-356-717-01	LEVER (JOINT)		115	3-356-619-01	SPRING (B), TORSION	
103	3-356-626-01	SPRING, TENSION		116	X-3356-627-1	GEAR (T) ASSY	
104	X-3356-613-1	PLATE ASSY, ORNAMENTAL		117	X-3356-628-1	GEAR (S) ASSY	
105	X-3343-456-1	LEVER (PINCH R) ASSY		118	3-356-625-01	SPRING, TENSION	
106	X-3343-455-1	LEVER (PINCH F) ASSY		119	3-319-224-31	DAMPER, SMALL	
107	A-2003-723-A	BASE ASSY, HEAD		120	3-362-308-01	CAP (REEL)	
108	X-3362-819-2	SLIDER (HEAD CHASSIS R) ASSY		121	3-356-716-01	SCREW (2X4) (B TIGHT), +P	
109	X-3356-641-1	LEVER (FR2) ASSY		122	3-669-465-11	WASHER (1.5), STOPPER	
110	3-356-614-01	SLIDER (BRAKE)		D1001	8-719-980-85	DIODE SLF-325C	
111	3-356-601-11	SCREW, STEP		D1091	8-719-950-74	DIODE SLR-314D-B	
112	* X-3356-608-1	LEVER (LIFTER) ASSY		Q1091	8-729-809-43	PHOTO SENSOR SPS-314B-BE	
113	3-356-713-01	WASHER					

6-4. MECHANISM DECK SECTION 2
(TCM-200R5)

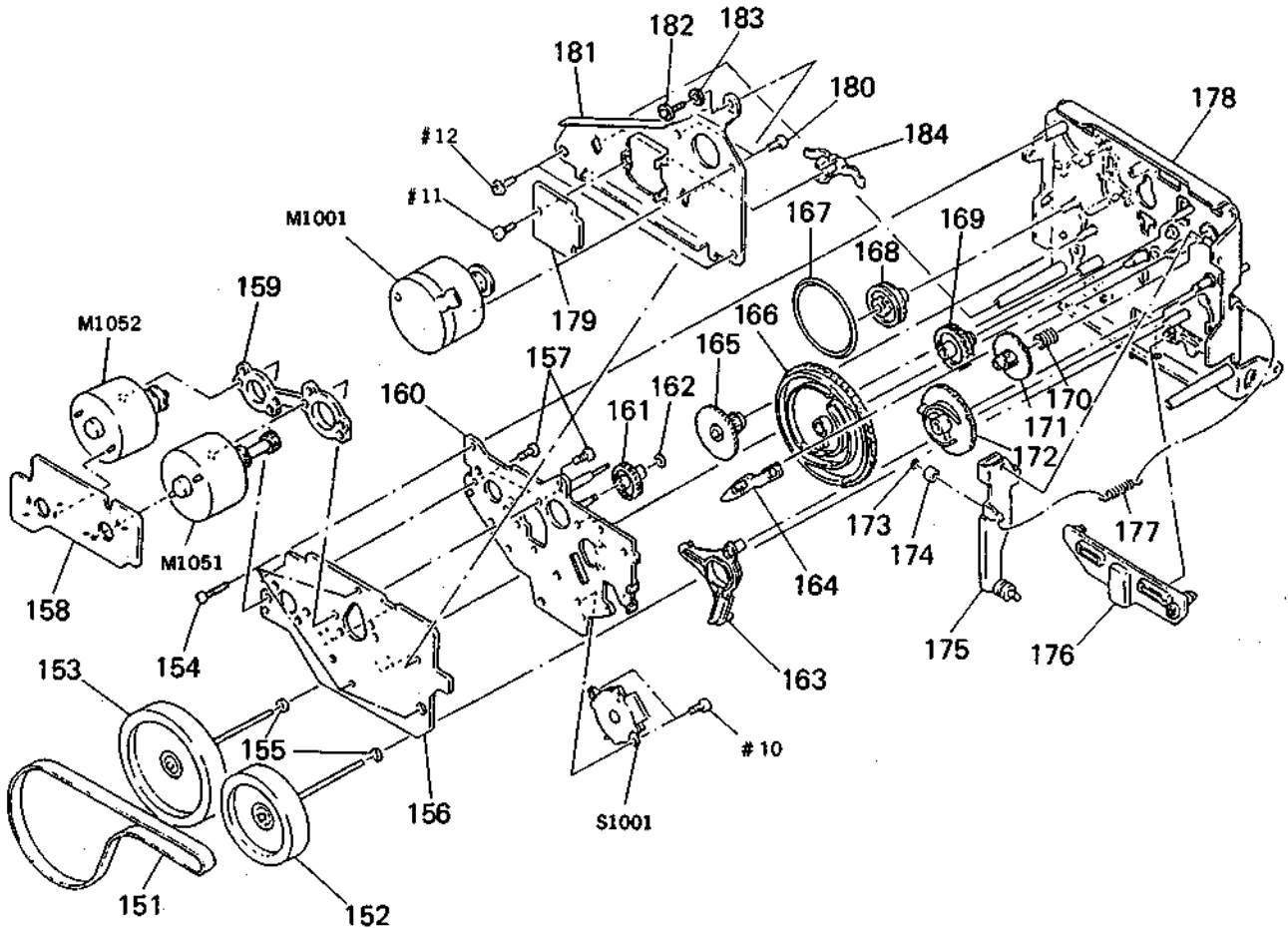

Ref. No.	Part No.	Description	Remark	Ref. No.	Part No.	Description	Remark
151	3-356-604-01	BELT (CAPSTAN)		170	3-356-605-01	SPRING, COMPRESSION	
152	X-3356-642-1	FLYWHEEL (R FWD) ASSY		171	3-356-609-01	GEAR (LOADING)	
153	X-3356-643-1	FLYWHEEL (R REV) ASSY		172	3-356-616-01	GEAR (LOADING CAM)	
154	3-355-801-01	SCREW (BTP 2X18)		173	3-558-708-11	WASHER, STOPPER	
155	3-356-705-01	WASHER (CAPSTAN)		174	3-356-630-01	ROLLER (LOADING)	
156	* 1-632-740-11	MD BOARD		175	* X-3356-606-1	LEVER (LOADING) ASSY	
157	3-363-804-01	SCREW (+P 2.6X6.5)		176	3-356-612-01	SLIDER (REVERSE)	
158	* 1-632-741-11	REEL MOTOR BOARD		177	3-356-624-01	SPRING, TENSION	
159	* 3-356-628-01	SPACER (MOTOR)		178	X-3356-634-1	CHASSIS (R2) COMPLETE ASSY. MECH	
160	* X-3356-602-4	BRACKET (MOTOR R) ASSY		179	* 1-634-323-11	TRANSLATION BOARD	
161	3-356-702-01	GEAR (COMMUNICATION B)		180	4-885-599-00	SCREW, FITTING, REINFORCEMENT	
162	3-669-465-00	WASHER (1.5), STOPPER		181	* 3-356-629-01	BRACKET (THRUST RETAINER R)	
163	3-356-613-01	LEVER (MODE)		182	3-356-707-01	SCREW (+PTPW 2X25)	
164	3-356-617-01	LEVER (SELECTION)		183	* 3-356-718-01	SPACER (THRUST RETAINER R)	
165	3-356-606-01	GEAR (MODE)		184	3-575-321-00	RETAINER, THRUST, CAPSTAN	
166	3-356-615-01	GEAR (MODE CAM RR)		M1001	X-3356-605-1	MOTOR (CAPSTAN R) ASSY	
167	3-356-603-01	BELT (MODE)		M1051	X-3356-638-1	MOTOR (REEL R) ASSY	
168	3-356-607-01	PULLEY (MODE)		M1052	X-3356-604-1	MOTOR (ASSIST) ASSY	
169	3-356-703-01	GEAR (COMMUNICATION C)		S1001	1-466-525-11	ENCODER, ROTARY	

SECTION 7 ELECTRICAL PARTS LIST

MAIN

NOTE:

- Due to standardization, replacements in the parts list may be different from the parts specified in the diagrams or the components used on the set.
- Items marked "*" are not stocked since they are seldom required for routine service. Some delay should be anticipated when ordering these items.
- -XX, -X mean standardized parts, so they may have some differences from the original one.
- CAPACITORS
uF: μ F

- RESISTORS
All resistors are in ohms
METAL: Metal-film resistor
METAL OXIDE: Metal Oxide-film resistor
F: nonflammable
- COILS
uH: μ H
- SEMICONDUCTORS
In each case, u: μ , for example:
uA...: μ A..., uPA...: μ PA...,
uPB...: μ PB..., uPC...: μ PC...,
uPD...: μ PD...

The components identified by mark Δ or dotted line with mark Δ are critical for safety. Replace only with part number specified.

When indicating parts by reference number, please include the board name.

Ref. No.	Part No.	Description	Remark	Ref. No.	Part No.	Description	Remark
* A-2006-392-A MAIN BOARD, COMPLETE *****				C145	1-136-433-11	FILM 100PF 5% 630V	
* 3-309-144-21 HEAT SINK				C146	1-130-472-00	MYLAR 0.0012uF 5% 50V	
* 3-356-925-01 HEAT SINK				C151	1-136-273-91	FILM 75PF 5% 630V	
* 4-880-403-11 HEAT SINK				C152	1-162-288-31	CERAMIC 330PF 10% 50V	
7-682-548-09 SCREW +B 3X8				C153	1-110-342-11	MYLAR 390PF 5% 50V	
7-682-548-04 SCREW +BVTT 3X8 (S)				C154	1-136-157-00	FILM 0.022uF 5% 50V	
< CAPACITOR >				C155	1-124-657-00	ELECT 10uF 20% 50V	
C101	1-124-925-11	ELECT 2.2uF 20% 100V		C191	1-123-382-00	ELECT 3.3uF 20% 100V	
C102	1-136-157-00	FILM 0.022uF 5% 50V		C201	1-124-925-11	ELECT 2.2uF 20% 100V	
C103	1-162-294-31	CERAMIC 0.001uF 10% 50V		C202	1-136-157-00	FILM 0.022uF 5% 50V	
C104	1-161-375-00	CERAMIC 0.0022uF 20% 50V		C203	1-162-294-31	CERAMIC 0.001uF 10% 50V	
C105	1-130-475-00	MYLAR 0.0022uF 5% 50V		C204	1-161-375-00	CERAMIC 0.0022uF 20% 50V	
C106	1-130-475-00	MYLAR 0.0022uF 5% 50V		C205	1-130-475-00	MYLAR 0.0022uF 5% 50V	
C107	1-136-174-00	FILM 0.56uF 5% 50V		C206	1-130-475-00	MYLAR 0.0022uF 5% 50V	
C108	1-136-171-00	FILM 0.33uF 5% 50V		C207	1-136-174-00	FILM 0.56uF 5% 50V	
C109	1-124-927-11	ELECT 4.7uF 20% 100V		C208	1-136-171-00	FILM 0.33uF 5% 50V	
C110	1-124-927-11	ELECT 4.7uF 20% 100V		C209	1-124-927-11	ELECT 4.7uF 20% 100V	
C121	1-136-153-00	FILM 0.01uF 5% 50V		C210	1-124-927-11	ELECT 4.7uF 20% 100V	
C122	1-136-157-00	FILM 0.022uF 5% 50V		C221	1-136-153-00	FILM 0.01uF 5% 50V	
C123	1-136-165-00	FILM 0.1uF 5% 50V		C222	1-136-157-00	FILM 0.022uF 5% 50V	
C124	1-136-437-11	FILM 220PF 5% 630V		C223	1-136-165-00	FILM 0.1uF 5% 50V	
C125	1-136-433-11	FILM 100PF 5% 630V		C224	1-136-437-11	FILM 220PF 5% 630V	
C126	1-130-472-00	MYLAR 0.0012uF 5% 50V		C225	1-136-433-11	FILM 100PF 5% 630V	
C131	1-136-273-91	FILM 75PF 5% 630V		C226	1-130-472-00	MYLAR 0.0012uF 5% 50V	
C132	1-162-288-31	CERAMIC 330PF 10% 50V		C231	1-136-273-91	FILM 75PF 5% 630V	
C133	1-110-342-11	MYLAR 390PF 5% 50V		C232	1-162-288-31	CERAMIC 330PF 10% 50V	
C134	1-136-157-00	FILM 0.022uF 5% 50V		C233	1-110-342-11	MYLAR 390PF 5% 50V	
C135	1-124-657-00	ELECT 10uF 20% 50V		C234	1-136-157-00	FILM 0.022uF 5% 50V	
C141	1-136-153-00	FILM 0.01uF 5% 50V		C235	1-124-657-00	ELECT 10uF 20% 50V	
C142	1-136-157-00	FILM 0.022uF 5% 50V		C241	1-136-153-00	FILM 0.01uF 5% 50V	
C143	1-136-165-00	FILM 0.1uF 5% 50V		C242	1-136-157-00	FILM 0.022uF 5% 50V	
C144	1-136-437-11	FILM 220PF 5% 630V		C243	1-136-165-00	FILM 0.1uF 5% 50V	
				C244	1-136-437-11	FILM 220PF 5% 630V	
				C245	1-136-433-11	FILM 100PF 5% 630V	
				C246	1-130-472-00	MYLAR 0.0012uF 5% 50V	

MAIN

Ref. No.	Part No.	Description	Remark		
C251	1-136-273-91	FILM	75PF	5%	630V
C252	1-162-288-31	CERAMIC	330PF	10%	50V
C253	1-110-342-11	MYLAR	390PF	5%	50V
C254	1-136-157-00	FILM	0.022uF	5%	50V
C255	1-124-657-00	ELECT	10uF	20%	50V
C281	1-123-382-00	ELECT	3.3uF	20%	100V
C501	1-124-903-11	ELECT	1uF	20%	50V
C502	1-124-925-11	ELECT	2.2uF	20%	100V
C503	1-124-925-11	ELECT	2.2uF	20%	100V
C521	1-124-925-11	ELECT	2.2uF	20%	100V
C522	1-124-902-00	ELECT	0.47uF	20%	50V
C523	1-136-230-00	FILM	0.0022uF	5%	100V
C524	1-136-230-00	FILM	0.0022uF	5%	100V
C525	1-130-856-00	FILM	0.0068uF	5%	100V
C526	1-124-907-11	ELECT	10uF	20%	50V
C527	1-136-601-11	FILM	0.01uF	5%	630V
C528	1-124-477-11	ELECT	47uF	20%	25V
C529	1-124-477-11	ELECT	47uF	20%	25V
C530	1-107-045-00	MICA	3.9PF		500V
C535	1-126-176-11	ELECT	220uF	20%	10V
C536	1-126-176-11	ELECT	220uF	20%	10V
C541	1-124-925-11	ELECT	2.2uF	20%	100V
C542	1-124-902-00	ELECT	0.47uF	20%	50V
C543	1-136-230-00	FILM	0.0022uF	5%	100V
C544	1-136-230-00	FILM	0.0022uF	5%	100V
C545	1-130-856-00	FILM	0.0068uF	5%	100V
C546	1-124-907-11	ELECT	10uF	20%	50V
C547	1-136-601-11	FILM	0.01uF	5%	630V
C548	1-124-477-11	ELECT	47uF	20%	25V
C549	1-124-477-11	ELECT	47uF	20%	25V
C550	1-107-045-00	MICA	3.9PF		500V
C555	1-126-176-11	ELECT	220uF	20%	10V
C556	1-126-176-11	ELECT	220uF	20%	10V
C561	1-124-120-11	ELECT	220uF	20%	25V
C581	1-124-925-11	ELECT	2.2uF	20%	100V
C582	1-162-217-31	CERAMIC	56PF	5%	50V
C583	1-136-157-00	FILM	0.022uF	5%	50V
C585	1-162-286-31	CERAMIC	220PF	10%	50V
C586	1-124-925-11	ELECT	2.2uF	20%	100V
C587	1-124-925-11	ELECT	2.2uF	20%	100V
C701	1-124-927-11	ELECT	4.7uF	20%	100V
C702	1-124-772-11	ELECT	10000uF	20%	25V
C703	1-124-126-00	ELECT	47uF	20%	10V
C704	1-124-898-11	ELECT	4700uF	20%	16V
C705	1-124-556-11	ELECT	2200uF	20%	16V
C706	1-124-443-00	ELECT	100uF	20%	10V
C707	1-124-471-00	ELECT	1000uF	20%	6.3V
C708	1-124-919-11	ELECT	220uF	20%	63V
C709	1-124-927-11	ELECT	4.7uF	20%	100V

Ref. No.	Part No.	Description	Remark		
C710	1-124-927-11	ELECT	4.7uF	20%	100V
C751	1-124-556-11	ELECT	2200uF	20%	16V
C752	1-124-556-11	ELECT	2200uF	20%	16V
C753	1-124-120-11	ELECT	220uF	20%	25V
C754	1-124-120-11	ELECT	220uF	20%	25V
C755	1-124-925-11	ELECT	2.2uF	20%	100V
C756	1-162-286-31	CERAMIC	220PF	10%	50V
C757	1-162-286-31	CERAMIC	220PF	10%	50V
C758	1-126-176-11	ELECT	220uF	20%	10V
C759	1-126-176-11	ELECT	220uF	20%	10V
C801	1-124-443-00	ELECT	100uF	20%	10V
C803	1-161-494-00	CERAMIC	0.022uF		25V
C804	1-162-306-11	CERAMIC	0.01uF	20%	16V
C805	1-124-925-11	ELECT	2.2uF	20%	100V
C807	1-164-159-11	CERAMIC	0.1uF		50V
C811	1-126-233-11	ELECT	22uF	20%	50V
C831	1-124-927-11	ELECT	4.7uF	20%	100V
C832	1-124-477-11	ELECT	47uF	20%	25V
C833	1-130-479-00	MYLAR	0.0047uF	5%	50V
C841	1-124-927-11	ELECT	4.7uF	20%	100V
C842	1-124-477-11	ELECT	47uF	20%	25V
C843	1-130-479-00	MYLAR	0.0047uF	5%	50V
C851	1-124-443-00	ELECT	100uF	20%	10V
C871	1-164-159-11	CERAMIC	0.1uF		50V
C872	1-164-159-11	CERAMIC	0.1uF		50V
C881	1-164-159-11	CERAMIC	0.1uF		50V
C882	1-164-159-11	CERAMIC	0.1uF		50V

< CONNECTOR >

CN541 * 1-564-336-00 PIN. CONNECTOR 2P
 CN561 * 1-564-705-11 PIN. CONNECTOR (SMALL TYPE) 3P
 CN562 * 1-564-705-11 PIN. CONNECTOR (SMALL TYPE) 3P
 CN571 * 1-564-707-11 PIN. CONNECTOR (SMALL TYPE) 5P
 CN701 * 1-564-513-11 PLUG. CONNECTOR 10P

CN801 * 1-564-340-61 PIN. CONNECTOR 6P
 CN802 * 1-564-510-11 PLUG. CONNECTOR 7P
 CN803 * 1-564-338-00 PIN. CONNECTOR 4P
 CN804 * 1-564-338-61 PIN. CONNECTOR 4P
 CN805 * 1-564-338-71 PIN. CONNECTOR 4P

CNP601 * 1-560-339-00 PIN. CONNECTOR 9P
 CNP602 * 1-560-339-00 PIN. CONNECTOR 9P

< COMPOSITION CIRCUIT BLOCK >

CP851 1-233-199-11 COMPOSITION CIRCUIT BLOCK 10KX8
 CP852 1-233-199-11 COMPOSITION CIRCUIT BLOCK 10KX8

MAIN

Ref. No.	Part No.	Description	Remark	Ref. No.	Part No.	Description	Remark
< DIODE >							
D191	8-719-912-20	DIODE 1SS120		IC806	8-759-822-09	IC LB1641	
D291	8-719-912-20	DIODE 1SS120		IC807	8-759-973-95	IC BA6219B	
D501	8-719-912-20	DIODE 1SS120		IC808	8-759-822-09	IC LB1641	
D502	8-719-912-20	DIODE 1SS120		< COIL >			
D503	8-719-933-54	DIODE HZS9A2L		L131	1-410-780-11	INDUCTOR 27mH	
D521	8-719-912-20	DIODE 1SS120		L151	1-410-780-11	INDUCTOR 27mH	
D522	8-719-912-20	DIODE 1SS120		L231	1-410-780-11	INDUCTOR 27mH	
D541	8-719-912-20	DIODE 1SS120		L251	1-410-780-11	INDUCTOR 27mH	
D542	8-719-912-20	DIODE 1SS120		< FILTER >			
D561	8-719-912-20	DIODE 1SS120		LPF101	1-235-980-11	FILTER, LOW PASS	
D701	8-719-200-77	DIODE 10E2N		LPF201	1-235-980-11	FILTER, LOW PASS	
D702	△ 8-719-500-36	DIODE D2SB20		< JACK >			
D703	8-719-912-20	DIODE 1SS120		PJ561	1-565-258-11	JACK, PIN 4P (LINE IN/OUT)	
D704	8-719-933-70	DIODE HZS11C2L		< TRANSISTOR >			
D705	8-719-200-77	DIODE 10E2N		Q101	8-729-900-74	TRANSISTOR DTC143TS	
D706	8-719-933-41	DIODE HZS6C3L		Q102	8-729-900-80	TRANSISTOR DTC114ES	
D707	8-719-912-20	DIODE 1SS120		Q161	8-729-922-37	TRANSISTOR 2SD2144S	
D708	8-719-933-38	DIODE HZS6B3L		Q201	8-729-900-74	TRANSISTOR DTC143TS	
D751	8-719-200-77	DIODE 10E2N		Q202	8-729-900-80	TRANSISTOR DTC114ES	
D752	8-719-200-77	DIODE 10E2N		Q261	8-729-922-37	TRANSISTOR 2SD2144S	
D753	8-719-200-77	DIODE 10E2N		Q501	8-729-900-65	TRANSISTOR DTA144ES	
D754	8-719-200-77	DIODE 10E2N		Q502	8-729-900-65	TRANSISTOR DTA144ES	
D756	8-719-912-20	DIODE 1SS120		Q503	8-729-900-65	TRANSISTOR DTA144ES	
D757	8-719-933-33	DIODE HZS6A1L		Q504	8-729-900-65	TRANSISTOR DTA144ES	
D758	8-719-912-20	DIODE 1SS120		Q505	8-729-900-80	TRANSISTOR DTC114ES	
D759	8-719-912-20	DIODE 1SS120		Q521	8-729-900-65	TRANSISTOR DTA144ES	
D801	8-719-912-20	DIODE 1SS120		Q522	8-729-900-65	TRANSISTOR DTA144ES	
D802	8-719-912-20	DIODE 1SS120		Q523	8-729-900-61	TRANSISTOR DTA114ES	
D804	8-719-912-20	DIODE 1SS120		Q524	8-729-900-89	TRANSISTOR DTC144ES	
D805	8-719-912-20	DIODE 1SS120		Q525	8-729-900-89	TRANSISTOR DTC144ES	
D831	8-719-912-20	DIODE 1SS120		Q526	8-729-900-80	TRANSISTOR DTC114ES	
D841	8-719-912-20	DIODE 1SS120		Q527	8-729-821-04	TRANSISTOR 2SA1317-STU	
< IC >				Q528	8-729-194-57	TRANSISTOR 2SC945-P	
IC501	8-759-106-56	IC uPC1297CA		Q529	8-729-194-57	TRANSISTOR 2SC945-P	
IC502	8-759-106-56	IC uPC1297CA		Q541	8-729-900-65	TRANSISTOR DTA144ES	
IC503	8-759-111-44	IC uPC4570C-1		Q542	8-729-900-65	TRANSISTOR DTA144ES	
IC504	8-759-111-44	IC uPC4570C-1		Q543	8-729-900-61	TRANSISTOR DTA114ES	
IC505	8-752-035-94	IC CXA1331S		Q544	8-729-900-89	TRANSISTOR DTC144ES	
IC506	8-759-140-53	IC uPD4053BC		Q545	8-729-900-89	TRANSISTOR DTC144ES	
IC508	8-759-945-58	IC RC4558P		Q546	8-729-900-80	TRANSISTOR DTC114ES	
IC509	8-759-945-58	IC RC4558P		Q547	8-729-821-04	TRANSISTOR 2SA1317-STU	
IC801	8-759-636-41	IC M50944-159SP		Q548	8-729-194-57	TRANSISTOR 2SC945-P	
IC802	8-759-633-86	IC M50747-B83SP		Q549	8-729-194-57	TRANSISTOR 2SC945-P	
IC804	8-759-240-71	IC TC4071BP		Q561	8-729-900-65	TRANSISTOR DTA144ES	
IC805	8-759-973-95	IC BA6219B					

Note: The components identified by mark △ or dotted line with mark △ are critical for safety. Replace only with part number specified.

MAIN

Ref. No.	Part No.	Description	Remark
Q562	8-729-821-04	TRANSISTOR 2SA1317-STU	
Q581	8-729-900-65	TRANSISTOR DTA144ES	
Q582	8-729-900-89	TRANSISTOR DTC144ES	
Q701	8-729-620-05	TRANSISTOR 2SC2603-EF	
Q702	8-729-924-90	TRANSISTOR 2SB1370-EF	
Q703	8-729-620-05	TRANSISTOR 2SC2603-EF	
Q704	8-729-620-05	TRANSISTOR 2SC2603-EF	
Q705	8-729-111-55	TRANSISTOR 2SD1312-K	
Q706	8-729-821-04	TRANSISTOR 2SA1317-STU	
Q707	8-729-140-04	TRANSISTOR 2SB1116A-L	
Q751	8-729-620-05	TRANSISTOR 2SC2603-EF	
Q752	8-729-111-55	TRANSISTOR 2SD1312-K	
Q753	8-729-620-05	TRANSISTOR 2SC2603-EF	
Q754	8-729-821-04	TRANSISTOR 2SA1317-STU	
Q755	8-729-924-90	TRANSISTOR 2SB1370-EF	
Q756	8-729-821-04	TRANSISTOR 2SA1317-STU	
Q757	8-729-821-04	TRANSISTOR 2SA1317-STU	
Q801	8-729-620-05	TRANSISTOR 2SC2603-EF	
Q802	8-729-620-05	TRANSISTOR 2SC2603-EF	
Q803	8-729-821-04	TRANSISTOR 2SA1317-STU	
Q831	8-729-620-05	TRANSISTOR 2SC2603-EF	
Q832	8-729-620-05	TRANSISTOR 2SC2603-EF	
Q841	8-729-620-05	TRANSISTOR 2SC2603-EF	
Q842	8-729-620-05	TRANSISTOR 2SC2603-EF	
Q871	8-729-900-65	TRANSISTOR DTA144ES	
Q872	8-729-900-80	TRANSISTOR DTC114ES	
Q873	8-729-900-80	TRANSISTOR DTC114ES	
Q874	8-729-900-80	TRANSISTOR DTC114ES	
Q881	8-729-900-65	TRANSISTOR DTA144ES	
Q882	8-729-900-89	TRANSISTOR DTC144ES	
Q883	8-729-900-80	TRANSISTOR DTC114ES	
Q884	8-729-900-80	TRANSISTOR DTC114ES	
Q885	8-729-900-80	TRANSISTOR DTC114ES	
< RESISTOR >			
R101	1-249-421-11	CARBON 2.2K	5% 1/4W
R102	1-249-423-11	CARBON 3.3K	5% 1/4W
R103	1-247-887-00	CARBON 220K	5% 1/4W
R104	1-249-441-11	CARBON 100K	5% 1/4W
R105	1-249-423-11	CARBON 3.3K	5% 1/4W
R106	1-249-428-11	CARBON 8.2K	5% 1/4W
R107	1-247-864-11	CARBON 24K	5% 1/4W
R108	1-249-414-11	CARBON 560	5% 1/4W
R121	1-249-427-11	CARBON 6.8K	5% 1/4W
R122	1-249-431-11	CARBON 15K	5% 1/4W
R123	△ 1-219-153-11	FUSIBLE 10	5% 1/4W F
R124	1-247-884-11	CARBON 160K	5% 1/4W
R131	1-249-430-11	CARBON 12K	5% 1/4W
R132	1-247-881-00	CARBON 120K	5% 1/4W

Ref. No.	Part No.	Description	Remark
R133	1-249-405-11	CARBON 100	5% 1/4W
R134	1-247-882-11	CARBON 130K	5% 1/4W
R135	1-249-426-11	CARBON 5.6K	5% 1/4W
R141	1-249-427-11	CARBON 6.8K	5% 1/4W
R142	1-249-431-11	CARBON 15K	5% 1/4W
R143	△ 1-219-153-11	FUSIBLE 10	5% 1/4W F
R144	1-247-884-11	CARBON 160K	5% 1/4W
R151	1-249-430-11	CARBON 12K	5% 1/4W
R152	1-247-881-00	CARBON 120K	5% 1/4W
R153	1-249-405-11	CARBON 100	5% 1/4W
R154	1-247-882-11	CARBON 130K	5% 1/4W
R155	1-249-426-11	CARBON 5.6K	5% 1/4W
R161	1-249-433-11	CARBON 22K	5% 1/4W
R162	1-249-417-11	CARBON 1K	5% 1/4W
R163	1-249-421-11	CARBON 2.2K	5% 1/4W
R164	1-249-432-11	CARBON 18K	5% 1/4W
R165	1-249-421-11	CARBON 2.2K	5% 1/4W
R191	1-249-429-11	CARBON 10K	5% 1/4W
R192	1-247-864-11	CARBON 24K	5% 1/4W
R193	1-249-434-11	CARBON 27K	5% 1/4W
R194	1-249-408-11	CARBON 180	5% 1/4W
R201	1-249-421-11	CARBON 2.2K	5% 1/4W
R202	1-249-423-11	CARBON 3.3K	5% 1/4W
R203	1-247-887-00	CARBON 220K	5% 1/4W
R204	1-249-441-11	CARBON 100K	5% 1/4W
R205	1-249-423-11	CARBON 3.3K	5% 1/4W
R206	1-249-428-11	CARBON 8.2K	5% 1/4W
R207	1-247-864-11	CARBON 24K	5% 1/4W
R208	1-249-414-11	CARBON 560	5% 1/4W
R221	1-249-427-11	CARBON 6.8K	5% 1/4W
R222	1-249-431-11	CARBON 15K	5% 1/4W
R223	△ 1-219-153-11	FUSIBLE 10	5% 1/4W F
R224	1-247-884-11	CARBON 160K	5% 1/4W
R231	1-249-430-11	CARBON 12K	5% 1/4W
R232	1-247-881-00	CARBON 120K	5% 1/4W
R233	1-249-405-11	CARBON 100	5% 1/4W
R234	1-247-882-11	CARBON 130K	5% 1/4W
R235	1-249-426-11	CARBON 5.6K	5% 1/4W
R241	1-249-427-11	CARBON 6.8K	5% 1/4W
R242	1-249-431-11	CARBON 15K	5% 1/4W
R243	△ 1-219-153-11	FUSIBLE 10	5% 1/4W F
R244	1-247-884-11	CARBON 160K	5% 1/4W
R251	1-249-430-11	CARBON 12K	5% 1/4W
R252	1-247-881-00	CARBON 120K	5% 1/4W
R253	1-249-405-11	CARBON 100	5% 1/4W
R254	1-247-882-11	CARBON 130K	5% 1/4W
R255	1-249-426-11	CARBON 5.6K	5% 1/4W
R261	1-249-433-11	CARBON 22K	5% 1/4W
R262	1-249-417-11	CARBON 1K	5% 1/4W

Note: The components identified by mark △ or dotted line with mark △ are critical for safety. Replace only with part number specified.

MAIN

Ref. No.	Part No.	Description	Remark		
R263	1-249-421-11	CARBON	2. 2K	5%	1/4W
R264	1-249-432-11	CARBON	18K	5%	1/4W
R265	1-249-421-11	CARBON	2. 2K	5%	1/4W
R291	1-249-429-11	CARBON	10K	5%	1/4W
R292	1-247-864-11	CARBON	24K	5%	1/4W
R293	1-249-434-11	CARBON	27K	5%	1/4W
R294	1-249-408-11	CARBON	180	5%	1/4W
R501	1-249-441-11	CARBON	100K	5%	1/4W
R502	1-249-417-11	CARBON	1K	5%	1/4W
R503	1-215-455-00	METAL	27K	1%	1/6W
R504	1-249-417-11	CARBON	1K	5%	1/4W
R505	1-249-433-11	CARBON	22K	5%	1/4W
R506	1-249-433-11	CARBON	22K	5%	1/4W
R507	1-249-433-11	CARBON	22K	5%	1/4W
R521	1-249-425-11	CARBON	4. 7K	5%	1/4W
R522	1-249-422-11	CARBON	2. 7K	5%	1/4W
R523	1-249-428-11	CARBON	8. 2K	5%	1/4W
R524	1-249-441-11	CARBON	100K	5%	1/4W
R526	1-247-846-11	CARBON	4. 3K	5%	1/4W
R527	1-249-421-11	CARBON	2. 2K	5%	1/4W
R528	1-249-429-11	CARBON	10K	5%	1/4W
R529	1-249-441-11	CARBON	100K	5%	1/4W
R530	1-249-441-11	CARBON	100K	5%	1/4W
R531	1-249-390-11	CARBON	5. 6	5%	1/6W
R532	1-249-390-11	CARBON	5. 6	5%	1/6W
R541	1-249-425-11	CARBON	4. 7K	5%	1/4W
R542	1-249-422-11	CARBON	2. 7K	5%	1/4W
R543	1-249-428-11	CARBON	8. 2K	5%	1/4W
R544	1-249-441-11	CARBON	100K	5%	1/4W
R546	1-249-422-11	CARBON	2. 7K	5%	1/4W
R547	1-249-421-11	CARBON	2. 2K	5%	1/4W
R548	1-249-429-11	CARBON	10K	5%	1/4W
R549	1-249-441-11	CARBON	100K	5%	1/4W
R550	1-249-441-11	CARBON	100K	5%	1/4W
R551	1-249-390-11	CARBON	5. 6	5%	1/6W
R552	1-249-390-11	CARBON	5. 6	5%	1/6W
R561	1-249-409-11	CARBON	220	5%	1/4W
R562	1-249-433-11	CARBON	22K	5%	1/4W
R581	1-247-887-00	CARBON	220K	5%	1/4W
R582	1-249-425-11	CARBON	4. 7K	5%	1/4W
R583	1-249-441-11	CARBON	100K	5%	1/4W
R584	1-249-428-11	CARBON	8. 2K	5%	1/4W
R585	1-249-441-11	CARBON	100K	5%	1/4W
R586	1-249-423-11	CARBON	3. 3K	5%	1/4W
R587	1-249-421-11	CARBON	2. 2K	5%	1/4W
R588	1-249-441-11	CARBON	100K	5%	1/4W
R700	△ 1-219-119-11	FUSIBLE	0. 1	5%	1/4W F
R701	1-249-433-11	CARBON	22K	5%	1/4W
R702	1-249-421-11	CARBON	2. 2K	5%	1/4W

Ref. No.	Part No.	Description	Remark		
R703	△ 1-219-154-11	FUSIBLE	0. 12	10%	1/4W F
R704	△ 1-219-136-11	FUSIBLE	0. 22	10%	1/4W F
R705	1-249-422-11	CARBON	2. 7K	5%	1/4W
R706	1-249-421-11	CARBON	2. 2K	5%	1/4W
R707	1-249-421-11	CARBON	2. 2K	5%	1/4W
R708	1-249-430-11	CARBON	12K	5%	1/4W
R709	1-247-856-00	CARBON	11K	5%	1/4W
R710	1-249-436-11	CARBON	39K	5%	1/4W
R751	1-249-433-11	CARBON	22K	5%	1/4W
R752	1-249-421-11	CARBON	2. 2K	5%	1/4W
R753	1-249-421-11	CARBON	2. 2K	5%	1/4W
R754	1-249-421-11	CARBON	2. 2K	5%	1/4W
R755	1-249-421-11	CARBON	2. 2K	5%	1/4W
R756	1-249-417-11	CARBON	1K	5%	1/4W
R757	1-249-417-11	CARBON	1K	5%	1/4W
R758	1-249-417-11	CARBON	1K	5%	1/4W
R759	1-249-415-11	CARBON	680	5%	1/4W
R760	1-249-422-11	CARBON	2. 7K	5%	1/4W
R761	1-249-424-11	CARBON	3. 9K	5%	1/4W
R762	1-249-423-11	CARBON	3. 3K	5%	1/4W
R763	1-249-405-11	CARBON	100	5%	1/4W
R801	1-249-405-11	CARBON	100	5%	1/4W
R802	1-249-405-11	CARBON	100	5%	1/4W
R803	1-249-405-11	CARBON	100	5%	1/4W
R804	1-249-405-11	CARBON	100	5%	1/4W
R805	1-249-405-11	CARBON	100	5%	1/4W
R806	1-249-421-11	CARBON	2. 2K	5%	1/4W
R807	1-249-421-11	CARBON	2. 2K	5%	1/4W
R808	1-249-421-11	CARBON	2. 2K	5%	1/4W
R809	1-249-421-11	CARBON	2. 2K	5%	1/4W
R810	1-249-421-11	CARBON	2. 2K	5%	1/4W
R811	1-249-433-11	CARBON	22K	5%	1/4W
R812	1-249-433-11	CARBON	22K	5%	1/4W
R813	1-247-903-00	CARBON	1M	5%	1/4W
R814	1-249-425-11	CARBON	4. 7K	5%	1/4W
R815	1-249-433-11	CARBON	22K	5%	1/4W
R816	1-249-433-11	CARBON	22K	5%	1/4W
R817	1-249-424-11	CARBON	3. 9K	5%	1/4W
R818	1-249-433-11	CARBON	22K	5%	1/4W
R819	1-249-433-11	CARBON	22K	5%	1/4W
R820	1-249-429-11	CARBON	10K	5%	1/4W
R821	1-249-441-11	CARBON	100K	5%	1/4W
R822	1-249-417-11	CARBON	1K	5%	1/4W
R823	1-249-437-11	CARBON	47K	5%	1/4W
R826	1-249-429-11	CARBON	10K	5%	1/4W
R831	1-249-429-11	CARBON	10K	5%	1/4W
R832	1-249-433-11	CARBON	22K	5%	1/4W
R833	1-249-429-11	CARBON	10K	5%	1/4W
R834	1-249-421-11	CARBON	2. 2K	5%	1/4W

Note: The components identified by mark △ or dotted line with mark △ are critical for safety. Replace only with part number specified.

MAIN MD

Ref. No.	Part No.	Description	Remark
R835	1-249-429-11	CARBON	10K 5% 1/4W
R836	1-249-417-11	CARBON	1K 5% 1/4W
R837	1-249-412-11	CARBON	390 5% 1/4W
R841	1-249-429-11	CARBON	10K 5% 1/4W
R842	1-249-433-11	CARBON	22K 5% 1/4W
R843	1-249-429-11	CARBON	10K 5% 1/4W
R844	1-249-421-11	CARBON	2.2K 5% 1/4W
R845	1-249-429-11	CARBON	10K 5% 1/4W
R846	1-249-417-11	CARBON	1K 5% 1/4W
R847	1-249-412-11	CARBON	390 5% 1/4W
R851	1-247-903-00	CARBON	1M 5% 1/4W
R852	1-249-425-11	CARBON	4.7K 5% 1/4W
R853	1-249-425-11	CARBON	4.7K 5% 1/4W
R854	1-249-425-11	CARBON	4.7K 5% 1/4W
R855	1-249-425-11	CARBON	4.7K 5% 1/4W
R856	1-249-425-11	CARBON	4.7K 5% 1/4W
R857	1-249-425-11	CARBON	4.7K 5% 1/4W
R858	1-249-425-11	CARBON	4.7K 5% 1/4W
R859	1-249-425-11	CARBON	4.7K 5% 1/4W
R861	1-249-436-11	CARBON	39K 5% 1/4W
R862	1-249-436-11	CARBON	39K 5% 1/4W
R863	1-247-895-00	CARBON	470K 5% 1/4W
R864	1-247-895-00	CARBON	470K 5% 1/4W
R865	1-249-436-11	CARBON	39K 5% 1/4W
R866	1-249-436-11	CARBON	39K 5% 1/4W
R867	1-247-895-00	CARBON	470K 5% 1/4W
R868	1-247-895-00	CARBON	470K 5% 1/4W
R869	1-249-429-11	CARBON	10K 5% 1/4W
R871	1-249-433-11	CARBON	22K 5% 1/4W
R872	1-249-434-11	CARBON	27K 5% 1/4W
R873	1-249-411-11	CARBON	330 5% 1/4W
R874	1-247-830-11	CARBON	910 5% 1/4W
R875	1-249-418-11	CARBON	1.2K 5% 1/4W
R876	1-249-417-11	CARBON	1K 5% 1/4W
R877	△ 1-249-482-11	CARBON	4.7 5% 1/2W F
R878	1-249-421-11	CARBON	2.2K 5% 1/4W
R879	1-249-419-11	CARBON	1.5K 5% 1/4W
R880	1-249-417-11	CARBON	1K 5% 1/4W
R881	△ 1-249-482-11	CARBON	4.7 5% 1/2W F
R882	1-249-433-11	CARBON	22K 5% 1/4W
R883	1-249-434-11	CARBON	27K 5% 1/4W
R884	1-249-411-11	CARBON	330 5% 1/4W
R885	1-247-830-11	CARBON	910 5% 1/4W
R886	1-249-418-11	CARBON	1.2K 5% 1/4W
R887	1-249-417-11	CARBON	1K 5% 1/4W
R888	△ 1-249-482-11	CARBON	4.7 5% 1/2W F
R889	1-249-421-11	CARBON	2.2K 5% 1/4W
R890	1-249-419-11	CARBON	1.5K 5% 1/4W

Ref. No.	Part No.	Description	Remark
R891	1-249-417-11	CARBON	1K 5% 1/4W
R892	△ 1-249-482-11	CARBON	4.7 5% 1/2W F
R893	1-249-433-11	CARBON	22K 5% 1/4W
< VARIABLE RESISTOR >			
RV121	1-237-459-11	RES. ADJ. CARBON	10K
RV131	1-237-457-21	RES. ADJ. CARBON	2K
RV141	1-237-459-11	RES. ADJ. CARBON	10K
RV151	1-237-457-21	RES. ADJ. CARBON	2K
RV221	1-237-459-11	RES. ADJ. CARBON	10K
RV231	1-237-457-21	RES. ADJ. CARBON	2K
RV241	1-237-459-11	RES. ADJ. CARBON	10K
RV251	1-237-457-21	RES. ADJ. CARBON	2K
RV831	1-237-461-11	RES. ADJ. CARBON	50K
RV841	1-237-461-11	RES. ADJ. CARBON	50K
RV871	1-237-459-11	RES. ADJ. CARBON	10K
RV872	1-237-458-21	RES. ADJ. CARBON	5K
RV881	1-237-459-11	RES. ADJ. CARBON	10K
RV882	1-237-458-21	RES. ADJ. CARBON	5K
< RELAY >			
RY531	1-515-683-11	RELAY	
RY551	1-515-683-11	RELAY	
< TRANSFORMER >			
T121	1-433-367-11	TRANSFORMER, BIAS OSCILLATION	
T141	1-433-367-11	TRANSFORMER, BIAS OSCILLATION	
T221	1-433-367-11	TRANSFORMER, BIAS OSCILLATION	
T241	1-433-367-11	TRANSFORMER, BIAS OSCILLATION	
T521	1-433-366-11	TRANSFORMER, BIAS OSCILLATION	
T541	1-433-366-11	TRANSFORMER, BIAS OSCILLATION	
< TEST PIN >			
TP521	* 1-564-506-11	PLUG, CONNECTOR	3P
TP541	* 1-564-506-11	PLUG, CONNECTOR	3P
TP581	* 1-564-505-11	PLUG, CONNECTOR	2P
TP801	* 1-564-505-11	PLUG, CONNECTOR	2P
TP802	* 1-564-505-11	PLUG, CONNECTOR	2P
TP803	* 1-564-505-11	PLUG, CONNECTOR	2P
< CERAMIC >			
X801	1-577-358-21	VIBRATOR, CERAMIC	4MHz
X802	1-577-358-21	VIBRATOR, CERAMIC	4MHz

* 1-632-740-11 MD BOARD			

3-356-631-01 HOLDER (SENSOR)			

Note: The components identified by mark △ or dotted line with mark △ are critical for safety. Replace only with part number specified.

MD **COVER** **DISPLAY** **HP** **POWER SW** **PT** **REC EQ** **SW (A)** **SW (B)**

Ref. No.	Part No.	Description	Remark
		< CONNECTOR >	
CN1001	1-506-615-11	PIN, CONNECTOR 9P	
CN1002 *	1-564-502-11	PIN, CONNECTOR 10P	
		< IC >	
IC1001	8-749-920-97	IC PHOTO REFLECTOR GP2S22B	
IC1002	8-749-920-97	IC PHOTO REFLECTOR GP2S22B	
		< RESISTOR >	
R1001	1-249-408-11	CARBON 180 5% 1/4W	
R1002	1-249-408-11	CARBON 180 5% 1/4W	
		< SWITCH >	
S1002	1-570-953-11	SWITCH, PUSH (1 KEY) (DOOR)	
S1003	1-571-958-11	SWITCH, PUSH (1 KEY) (CLOSE)	
S1004	1-572-126-11	SWITCH, PUSH (1 KEY) (OPEN)	
S1005	1-572-125-11	SWITCH, LEAF (FWD TAB)	
S1006	1-572-202-11	SWITCH, LEAF (HALF)	
S1007	1-572-125-11	SWITCH, LEAF (METAL)	
S1008	1-572-125-11	SWITCH, LEAF (70uS)	
S1009	1-572-125-11	SWITCH, LEAF (REV TAB)	
		< CONNECTOR >	
TB1001 *	1-569-066-11	PIN, CONNECTOR 5P	

* A-2006-393-A PANEL BOARD, COMPLETE (INCL. COVER BOARD, DISPLAY BOARD, HP BOARD, POWER SW BOARD, PT BOARD, REC EQ BOARD, SW(A) BOARD, SW(B) BOARD)			

3-365-420-01 HOLDER, FL TUBE			
9-911-844-XX CUSHION			
		< CAPACITOR >	
C171	1-126-157-11	ELECT 10uF 20% 16V	
C172	1-162-288-31	CERAMIC 330PF 10% 50V	
C271	1-126-157-11	ELECT 10uF 20% 16V	
C272	1-162-288-31	CERAMIC 330PF 10% 50V	
C301	1-124-902-00	ELECT 0.47uF 20% 50V	
C303	1-124-927-11	ELECT 4.7uF 20% 100V	
C304	1-124-927-11	ELECT 4.7uF 20% 100V	
C351	1-124-902-00	ELECT 0.47uF 20% 50V	
C353	1-124-927-11	ELECT 4.7uF 20% 100V	
C354	1-124-927-11	ELECT 4.7uF 20% 100V	
C401	1-124-902-00	ELECT 0.47uF 20% 50V	
C403	1-124-927-11	ELECT 4.7uF 20% 100V	
C404	1-124-927-11	ELECT 4.7uF 20% 100V	

Ref. No.	Part No.	Description	Remark
C451	1-124-902-00	ELECT 0.47uF 20% 50V	
C453	1-124-927-11	ELECT 4.7uF 20% 100V	
C454	1-124-927-11	ELECT 4.7uF 20% 100V	
C571	1-126-157-11	ELECT 10uF 20% 16V	
C572	1-126-157-11	ELECT 10uF 20% 16V	
C573	1-161-494-00	CERAMIC 0.022uF 25V	
C601	1-124-903-11	ELECT 1uF 20% 50V	
C651	1-124-903-11	ELECT 1uF 20% 50V	
C901	1-161-494-00	CERAMIC 0.022uF 25V	
C902	1-164-159-11	CERAMIC 0.1uF 50V	
C903	1-124-443-00	ELECT 100uF 20% 10V	
C904	1-162-294-31	CERAMIC 0.001uF 10% 50V	
		< CONNECTOR >	
CN572 *	1-564-721-11	PIN, CONNECTOR (SMALL TYPE) 5P	
CNJ601 *	1-563-660-11	CONNECTOR 9P	
CNJ602 *	1-563-660-11	CONNECTOR 9P	
		< DIODE >	
D601	8-719-912-20	DIODE 1SS120	
D602	8-719-912-20	DIODE 1SS120	
D651	8-719-912-20	DIODE 1SS120	
D652	8-719-912-20	DIODE 1SS120	
		< FLUORESCENT INDICATOR >	
FL901	1-519-594-11	INDICATOR TUBE, FLUORESCENT	
		< IC >	
IC507	8-759-634-50	IC M5218AL	
IC601	8-752-038-02	IC CXA1198AP	
IC602	8-752-038-02	IC CXA1198AP	
IC603	8-759-208-06	IC TC4051BPHB	
IC901	8-759-323-40	IC HD614023SA85	
IC902	8-741-100-48	IC SBX1610-59	
		< JACK >	
J501	1-507-796-71	JACK (PHONES)	
		< TRANSISTOR >	
Q301	8-729-620-05	TRANSISTOR 2SC2603-EF	
Q351	8-729-620-05	TRANSISTOR 2SC2603-EF	
Q401	8-729-620-05	TRANSISTOR 2SC2603-EF	
Q451	8-729-620-05	TRANSISTOR 2SC2603-EF	
Q601	8-729-900-65	TRANSISTOR DTA144ES	
Q602	8-729-900-89	TRANSISTOR DTC144ES	
Q603	8-729-900-89	TRANSISTOR DTC144ES	
Q604	8-729-620-05	TRANSISTOR 2SC2603-EF	
Q605	8-729-900-89	TRANSISTOR DTC144ES	

COVER

DISPLAY

HP

POWER SW

PT

REC EQ

SW (A)

SW (B)

Ref. No.	Part No.	Description	Remark		
Q651	8-729-900-85	TRANSISTOR DTA144ES			
Q652	8-729-620-05	TRANSISTOR 2SC2603-EF			
Q653	8-729-900-89	TRANSISTOR DTC144ES			
Q901	8-729-900-61	TRANSISTOR DTA114ES			
Q902	8-729-900-61	TRANSISTOR DTA114ES			
Q903	8-729-620-05	TRANSISTOR 2SC2603-EF			
< RESISTOR >					
R171	1-249-432-11	CARBON	18K	5%	1/4W
R172	1-249-421-11	CARBON	2.2K	5%	1/4W
R173	1-249-432-11	CARBON	18K	5%	1/4W
R174	1-249-409-11	CARBON	220	5%	1/4W
R271	1-249-432-11	CARBON	18K	5%	1/4W
R272	1-249-421-11	CARBON	2.2K	5%	1/4W
R273	1-249-432-11	CARBON	18K	5%	1/4W
R274	1-249-409-11	CARBON	220	5%	1/4W
R301	1-249-429-11	CARBON	10K	5%	1/4W
R302	1-249-425-11	CARBON	4.7K	5%	1/4W
R304	1-249-425-11	CARBON	4.7K	5%	1/4W
R305	1-249-425-11	CARBON	4.7K	5%	1/4W
R306	1-249-425-11	CARBON	4.7K	5%	1/4W
R351	1-249-429-11	CARBON	10K	5%	1/4W
R352	1-249-425-11	CARBON	4.7K	5%	1/4W
R354	1-249-425-11	CARBON	4.7K	5%	1/4W
R355	1-249-425-11	CARBON	4.7K	5%	1/4W
R356	1-249-425-11	CARBON	4.7K	5%	1/4W
R401	1-249-429-11	CARBON	10K	5%	1/4W
R402	1-249-425-11	CARBON	4.7K	5%	1/4W
R404	1-249-425-11	CARBON	4.7K	5%	1/4W
R405	1-249-425-11	CARBON	4.7K	5%	1/4W
R406	1-249-425-11	CARBON	4.7K	5%	1/4W
R451	1-249-429-11	CARBON	10K	5%	1/4W
R452	1-249-425-11	CARBON	4.7K	5%	1/4W
R454	1-249-425-11	CARBON	4.7K	5%	1/4W
R455	1-249-425-11	CARBON	4.7K	5%	1/4W
R456	1-249-425-11	CARBON	4.7K	5%	1/4W
R545	1-249-424-11	CARBON	3.9K	5%	1/4W
R601	1-249-417-11	CARBON	1K	5%	1/4W
R602	1-249-441-11	CARBON	100K	5%	1/4W
R603	1-247-864-11	CARBON	24K	5%	1/4W
R604	1-249-433-11	CARBON	22K	5%	1/4W
R621	1-249-436-11	CARBON	39K	5%	1/4W
R622	1-249-435-11	CARBON	33K	5%	1/4W
R623	1-247-874-11	CARBON	62K	5%	1/4W
R624	1-247-880-11	CARBON	110K	5%	1/4W
R625	1-249-439-11	CARBON	68K	5%	1/4W
R626	1-249-439-11	CARBON	68K	5%	1/4W
R631	1-247-874-11	CARBON	62K	5%	1/4W

Ref. No.	Part No.	Description	Remark		
R632	1-247-870-11	CARBON	43K	5%	1/4W
R633	1-249-441-11	CARBON	100K	5%	1/4W
R634	1-247-880-11	CARBON	110K	5%	1/4W
R635	1-249-439-11	CARBON	68K	5%	1/4W
R636	1-247-887-00	CARBON	220K	5%	1/4W
R641	1-247-874-11	CARBON	62K	5%	1/4W
R642	1-247-872-11	CARBON	51K	5%	1/4W
R643	1-249-439-11	CARBON	68K	5%	1/4W
R644	1-249-440-11	CARBON	82K	5%	1/4W
R645	1-247-876-11	CARBON	75K	5%	1/4W
R646	1-247-887-00	CARBON	220K	5%	1/4W
R651	1-249-417-11	CARBON	1K	5%	1/4W
R652	1-249-441-11	CARBON	100K	5%	1/4W
R653	1-247-864-11	CARBON	24K	5%	1/4W
R655	1-247-887-00	CARBON	220K	5%	1/4W
R656	1-249-433-11	CARBON	22K	5%	1/4W
R657	1-249-425-11	CARBON	4.7K	5%	1/4W
R662	1-249-436-11	CARBON	39K	5%	1/4W
R663	1-249-435-11	CARBON	33K	5%	1/4W
R664	1-249-439-11	CARBON	68K	5%	1/4W
R665	1-247-881-00	CARBON	120K	5%	1/4W
R666	1-249-439-11	CARBON	68K	5%	1/4W
R667	1-249-439-11	CARBON	68K	5%	1/4W
R668	1-247-874-11	CARBON	62K	5%	1/4W
R669	1-247-870-11	CARBON	43K	5%	1/4W
R670	1-247-880-11	CARBON	110K	5%	1/4W
R671	1-247-881-00	CARBON	120K	5%	1/4W
R672	1-249-439-11	CARBON	68K	5%	1/4W
R673	1-247-887-00	CARBON	220K	5%	1/4W
R674	1-247-874-11	CARBON	62K	5%	1/4W
R675	1-247-872-11	CARBON	51K	5%	1/4W
R676	1-249-439-11	CARBON	68K	5%	1/4W
R677	1-247-878-00	CARBON	91K	5%	1/4W
R678	1-247-876-11	CARBON	75K	5%	1/4W
R679	1-247-891-00	CARBON	330K	5%	1/4W
R681	1-249-432-11	CARBON	18K	5%	1/4W
R682	1-249-436-11	CARBON	39K	5%	1/4W
R683	1-247-860-11	CARBON	16K	5%	1/4W
R684	1-249-435-11	CARBON	33K	5%	1/4W
R685	1-249-439-11	CARBON	68K	5%	1/4W
R686	1-247-885-00	CARBON	180K	5%	1/4W
R687	1-249-436-11	CARBON	39K	5%	1/4W
R688	1-247-872-11	CARBON	51K	5%	1/4W
R689	1-249-434-11	CARBON	27K	5%	1/4W
R690	1-249-435-11	CARBON	33K	5%	1/4W
R691	1-249-439-11	CARBON	68K	5%	1/4W
R692	1-247-883-00	CARBON	150K	5%	1/4W
R693	1-247-870-11	CARBON	43K	5%	1/4W
R694	1-247-874-11	CARBON	62K	5%	1/4W

COVER

DISPLAY

HP

POWER SW

PT

REC EQ

SW (A)

SW (B)

REEL MOTOR

Ref. No.	Part No.	Description	Remark
R695	1-249-433-11	CARBON 22K	5% 1/4W
R696	1-249-435-11	CARBON 33K	5% 1/4W
R697	1-249-439-11	CARBON 68K	5% 1/4W
R698	1-247-893-00	CARBON 150K	5% 1/4W
R902	1-249-433-11	CARBON 22K	5% 1/4W
R903	1-249-433-11	CARBON 22K	5% 1/4W
R904	1-249-417-11	CARBON 1K	5% 1/4W
R905	1-247-903-00	CARBON 1M	5% 1/4W
R906	1-249-441-11	CARBON 100K	5% 1/4W
R907	1-249-441-11	CARBON 100K	5% 1/4W
R908	1-249-441-11	CARBON 100K	5% 1/4W
R951	1-249-407-11	CARBON 150	5% 1/4W
R952	1-249-422-11	CARBON 2.7K	5% 1/4W
R955	1-249-420-11	CARBON 1.8K	5% 1/4W
R961	1-249-407-11	CARBON 150	5% 1/4W
R971	1-249-407-11	CARBON 150	5% 1/4W
R972	1-249-409-11	CARBON 220	5% 1/4W
R973	1-249-411-11	CARBON 330	5% 1/4W
R974	1-249-413-11	CARBON 470	5% 1/4W
R975	1-249-415-11	CARBON 680	5% 1/4W
R976	1-249-417-11	CARBON 1K	5% 1/4W
R977	1-249-420-11	CARBON 1.8K	5% 1/4W
R978	1-249-424-11	CARBON 3.9K	5% 1/4W
R981	1-249-407-11	CARBON 150	5% 1/4W
R982	1-249-409-11	CARBON 220	5% 1/4W
R983	1-249-411-11	CARBON 330	5% 1/4W
R984	1-249-413-11	CARBON 470	5% 1/4W
R985	1-249-415-11	CARBON 680	5% 1/4W
R986	1-249-417-11	CARBON 1K	5% 1/4W
R987	1-249-420-11	CARBON 1.8K	5% 1/4W
R988	1-249-424-11	CARBON 3.9K	5% 1/4W
R991	1-249-407-11	CARBON 150	5% 1/4W
R992	1-249-409-11	CARBON 220	5% 1/4W
R993	1-249-411-11	CARBON 330	5% 1/4W
R994	1-249-413-11	CARBON 470	5% 1/4W
R995	1-249-415-11	CARBON 680	5% 1/4W
R996	1-249-417-11	CARBON 1K	5% 1/4W
R997	1-249-420-11	CARBON 1.8K	5% 1/4W
R998	1-249-424-11	CARBON 3.9K	5% 1/4W
< VARIABLE RESISTOR >			
RV301	1-238-547-11	RES. ADJ. CARBON 10K	
RV351	1-238-547-11	RES. ADJ. CARBON 10K	
RV401	1-238-547-11	RES. ADJ. CARBON 10K	
RV451	1-238-547-11	RES. ADJ. CARBON 10K	
RV541	1-238-952-11	RES. VAR. CARBON 5K (BIAS (DECK B))	
RV561	1-241-133-11	RES. VAR. CARBON 50K/50K (REC LEVEL)	
RV562	1-238-953-11	RES. VAR. CARBON 50K/50K (BALANCE)	
RV571	1-238-085-11	RES. VAR. CARBON 20K/20K (PHONES LEVEL)	

Ref. No.	Part No.	Description	Remark
< SWITCH >			
S901	1-554-118-00	SWITCH. PUSH (1 KEY) (POWER)	
S951	1-554-303-21	SWITCH. TACTILE (BLANK SKIP)	
S952	1-554-303-21	SWITCH. TACTILE (AUTO PAUSE)	
S955	1-571-520-11	SWITCH. SLIDE (QNR)	
S961	1-571-520-11	SWITCH. SLIDE (TIMER)	
S971	1-554-303-21	SWITCH. TACTILE (A+B REC)	
S972	1-554-303-21	SWITCH. TACTILE (SYNCHRO DUBBING HIGH SPEED)	
S973	1-554-303-21	SWITCH. TACTILE (SYNCHRO DUBBING NORM SPEED)	
S974	1-554-303-21	SWITCH. TACTILE (COUNTER RESET (DECK A))	
S975	1-554-303-21	SWITCH. TACTILE (COUNTER MEMORY (DECK A))	
S976	1-554-303-21	SWITCH. TACTILE (COUNTER RESET (DECK B))	
S977	1-554-303-21	SWITCH. TACTILE (COUNTER MEMORY (DECK B))	
S978	1-571-520-11	SWITCH. SLIDE (DIR MODE)	
S981	1-554-303-21	SWITCH. TACTILE (△ OPEN/CLOSE (DECK A))	
S982	1-554-303-21	SWITCH. TACTILE (■ (DECK A))	
S983	1-554-303-21	SWITCH. TACTILE (▷ (DECK A))	
S984	1-554-303-21	SWITCH. TACTILE (◁ (DECK A))	
S985	1-554-303-21	SWITCH. TACTILE (PAUSE ■ (DECK A))	
S986	1-554-303-21	SWITCH. TACTILE (REC MUTE ○ (DECK A))	
S987	1-554-303-21	SWITCH. TACTILE (◀ (DECK B))	
S988	1-554-303-21	SWITCH. TACTILE (▶ (DECK B))	
S989	1-554-303-21	SWITCH. TACTILE (REC ● (DECK B))	
S991	1-554-303-21	SWITCH. TACTILE (△ OPEN/CLOSE (DECK B))	
S992	1-554-303-21	SWITCH. TACTILE (■ (DECK B))	
S993	1-554-303-21	SWITCH. TACTILE (▷ (DECK B))	
S994	1-554-303-21	SWITCH. TACTILE (◁ (DECK B))	
S995	1-554-303-21	SWITCH. TACTILE (PAUSE ■ (DECK B))	
S996	1-554-303-21	SWITCH. TACTILE (REC MUTE ○ (DECK B))	
S997	1-554-303-21	SWITCH. TACTILE (◀ (DECK A))	
S998	1-554-303-21	SWITCH. TACTILE (▶ (DECK A))	
S999	1-554-303-21	SWITCH. TACTILE (REC ● (DECK A))	
< CERAMIC >			
X901	1-577-359-21	VIBRATOR. CERAMIC 4.19MHZ	

* 1-632-741-11 REEL MOTOR BOARD			

M1051	X-3356-638-1	MOTOR (REEL R) ASSY	
M1052	X-3356-604-1	MOTOR (ASSIST) ASSY	
< CAPACITOR >			
C1051	1-124-907-11	ELECT 10uF 20% 50V	
C1052	1-124-907-11	ELECT 10uF 20% 50V	
C1053	1-164-159-11	CERAMIC 0.1uF 50V	

REEL MOTOR

SENSOR

TRANSLATION

Ref. No.	Part No.	Description	Remark
< CONNECTOR >			
CN1051	1-564-501-11	PIN. CONNECTOR 8P	
CN1052 *	1-564-720-11	PIN. CONNECTOR (SMALL TYPE) 4P	
CN1053 *	1-564-718-11	PIN. CONNECTOR (SMALL TYPE) 2P	
< RESISTOR >			
R1051	1-249-414-11	CARBON 560 5% 1/4W	

*	1-634-323-11	TRANSLATION BOARD	*****
< CONNECTOR >			
CN1091 *	1-564-709-11	PIN. CONNECTOR (SMALL TYPE) 7P	
CN1092 *	1-564-509-11	PLUG. CONNECTOR 6P	
CN1093 *	1-564-705-11	PIN. CONNECTOR (SMALL TYPE) 3P	
CN1094 *	1-564-506-11	PLUG. CONNECTOR 3P	

	1-638-161-11	SENSOR BOARD	*****
< DIODE >			
D1091	8-719-950-74	DIODE SLR-314D-B	
< TRANSISTOR >			
Q1091	8-729-809-43	PHOTO SENSOR SPS-314B-BE	

MISCELLANEOUS			

9	△ 1-555-465-00	CORD. POWER (US)	
10	△ 1-555-795-00	CORD. POWER. EULG PLUG (AEP, Germany)	
11	△ 1-556-035-00	CORD. POWER (UK)	
D1001	8-719-980-85	DIODE SLF-325C	
M1001	X-3356-605-1	MOTOR (CAPSTAN R) ASSY	
S1001	1-466-525-11	ENCODER. ROTARY	
T901	△ 1-450-444-11	TRANSFORMER. POWER (WR875)	
T901	△ 1-450-446-11	TRANSFORMER. POWER (WR770)	

Ref. No.	Part No.	Description	Remark
ACCESSORY & PACKING MATERIAL			

	1-559-533-11	CORD. CONNECTION	
*	3-354-913-01	CUSHION	
*	3-366-699-21	INDIVIDUAL CARTON (WR770)	
*	3-366-699-31	INDIVIDUAL CARTON (WR875)	
	3-703-450-01	INSTRUCTION (WR875)	
	3-753-345-11	MANUAL. INSTRUCTION (ENGLISH, FRENCH, SPANISH, PORTUGUESE) (AEP, UK)	
	3-753-345-21	MANUAL. INSTRUCTION (ENGLISH) (WR875)	
	3-753-345-41	MANUAL. INSTRUCTION (GERMAN, DUTCH, SWEDISH, ITALIAN) (AEP, Germany)	

HARDWARE LIST

# 1	7-682-547-09	SCREW +BVTT 3X6 (S)
# 2	7-682-548-09	SCREW +BVTT 3X8 (S)
# 3	7-682-547-04	SCREW +BVTT 3X6 (S)
# 4	7-682-548-04	SCREW +BVTT 3X8 (S)
# 5	7-621-849-00	SCREW (BV/RING)
# 6	7-685-133-19	SCREW +BTP 2.6X6 TYPE2 N-S
# 7	7-685-870-01	SCREW +BVTT 3X5 (S)
# 8	7-621-255-20	SCREW +BVTT 2X4 (S)
# 9	7-621-283-00	SCREW +BVTT 2X5 (S)
#10	7-621-255-35	SCREW +BVTT 2X5 (S)
#11	7-621-770-67	SCREW +BVTT 2.6X6 (S)
#12	7-685-131-19	SCREW +BTP 2.6X4 TYPE2 N-S

Note: The components identified by mark △ or dotted line with mark △ are critical for safety. Replace only with part number specified.