

# TC-WR720/WR720A

## SERVICE MANUAL

US Model  
Canadian Model  
E Model  
TC-WR720A  
AEP Model  
TC-WR720

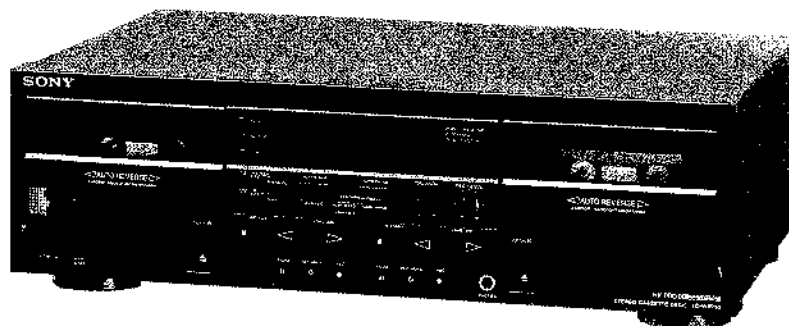

This photo is TC-WR720.

### SPECIFICATIONS

Recording system 4-track 2-channel stereo  
Fast winding time Approx. 90 sec. (with HF-60 cassette)  
Bias AC bias  
Signal-to-noise ratio (NAB, at peak level)

Cassette	Dolby NR switch		
	OFF	B-TYPE ON	C-TYPE ON
Type IV (Sony METAL-ES)	58dB	66dB	73dB
Type II (Sony UX-S)	57dB	65dB	72dB
Type I (Sony HF-S)	55dB (WR720) 54dB (WR720A)	63dB	70dB

Total harmonic distortion 1.0% (with Sony METAL-ES cassettes)  
Frequency response (DOLBY NR OFF)

Type IV cassette (Sony METAL-ES)	30-18,000Hz ( $\pm 3$ dB) (WR720)
	30-15,000Hz ( $\pm 3$ dB) (WR720A)
	30-14,000Hz (0VU recording) (WR720)
	30-13,000Hz (0VU recording) (WR720A)
Type II cassette (Sony UX-S)	30-17,000Hz ( $\pm 3$ dB) (WR720)
	20-15,000Hz ( $\pm 3$ dB) (WR720A)
Type I cassette (Sony HF-S)	30-15,000Hz ( $\pm 3$ dB) (WR720)
	30-14,000Hz ( $\pm 3$ dB) (WR720A)

Wow and flutter 0.07% WRMS (NAB)  
Inputs

Line inputs (phono jacks)	Sensitivity	77.5mV ( $-20$ dB)
	Input impedance	50kohms

Model Name Using Similar Mechanism	TC-WR620
Tape Transport Mechanism Type	TCM-190RB12

### Output

Line outputs (phono jacks)	Rated output level	0.44V ( $-5$ dB) at a load impedance of 47kohms
	Load impedance	Over 10kohms
Headphones (stereo phono jack)	Output level	0.3mW at a load impedance of 32 ohms

### General

Power requirements 120V AC, 60Hz (US, Canadian model)  
220V AC, 50/60Hz (AEP model)  
120, 220, 240, 50/60Hz (E model)  
Power consumption 33 watts  
Dimensions Approx. 430×135×285mm (w/h/d)  
(17×5<sup>3</sup>/<sub>8</sub>×11<sup>1</sup>/<sub>4</sub> inches)  
including projecting parts and controls  
Weight Approx. 5kg (11 lbs 1 oz) (WR720)  
Approx. 4.6kg (10 lbs 3 oz) (WR720A)  
Supplied accessories Audio connecting cord (2)  
Remote commander (RM-900W)  
(E model only)  
Conversion adaptor (E model only)

Design and specifications subject to change without notice.

STEREO CASSETTE DECK  
**SONY**®





## FEATURES

- **The Dolby HX PRO\* system** which improves the linearity of a tape's high-range response during recording.
- **A relay function** for long recording and playback.
- **Automatic tape type detection** during playback and recording.
- **Auto-synchro dubbing** at normal or high (double) speed.
- **AMS and memory play functions** which provide easy access to desired selections.
- **An easy-to-read digital counter** which shows the elapsed recording or playback time for decks A and B.

\*Dolby noise reduction and HX Pro headroom extension manufactured under license from Dolby Laboratories Licensing Corporation. HX Pro originated by Bang & Olufsen.

"DOLBY", the double-D symbol  and "HX PRO" are trademarks of Dolby Laboratories Licensing Corporation.

### SAFETY-RELATED COMPONENT WARNING!!

COMPONENTS IDENTIFIED BY MARK  OR DOTTED LINE WITH MARK  ON THE SCHEMATIC DIAGRAMS AND IN THE PARTS LIST ARE CRITICAL TO SAFE OPERATION. REPLACE THESE COMPONENTS WITH SONY PARTS WHOSE PART NUMBERS APPEAR AS SHOWN IN THIS MANUAL OR IN SUPPLEMENTS PUBLISHED BY SONY.

### ATTENTION AU COMPOSANT AYANT RAPPORT À LA SÉCURITÉ!

LES COMPOSANTS IDENTIFIÉS PAR UNE MARQUE  SUR LES DIAGRAMMES SCHÉMATIQUES ET LA LISTE DES PIÈCES SONT CRITIQUES POUR LA SÉCURITÉ DE FONCTIONNEMENT. NE REMPLACER CES COMPOSANTS QUE PAR DES PIÈCES SONY DONT LES NUMÉROS SONT DONNÉS DANS CE MANUEL OU DANS LES SUPPLÉMENTS PUBLIÉS PAR SONY.

## SAFETY CHECK-OUT

After correcting the original service problem, perform the following safety check before releasing the set to the customer:

Check the antenna terminals, metal trim, "metallized" knobs, screws, and all other exposed metal parts for AC leakage. Check leakage as described below.

### LEAKAGE TEST

The AC leakage from any exposed metal part to earth ground and from all exposed metal parts to any exposed metal part having a return to chassis, must not exceed 0.5 mA (500 microamperes). Leakage current can be measured by any one of three methods.

1. A commercial leakage tester, such as the Simpson 229 or RCA WT-540A. Follow the manufacturers' instructions to use these instruments.
2. A battery-operated AC milliammeter. The Data Precision 245 digital multimeter is suitable for this job.
3. Measuring the voltage drop across a resistor by means of a VOM or battery-operated AC voltmeter. The "limit" indication is 0.75 V, so analog meters must have an accurate low-voltage scale. The Simpson 250 and Sanwa SH-63Trd are examples of a passive VOM that is suitable. Nearly all battery operated digital multimeters that have a 2V AC range are suitable. (See Fig. A)

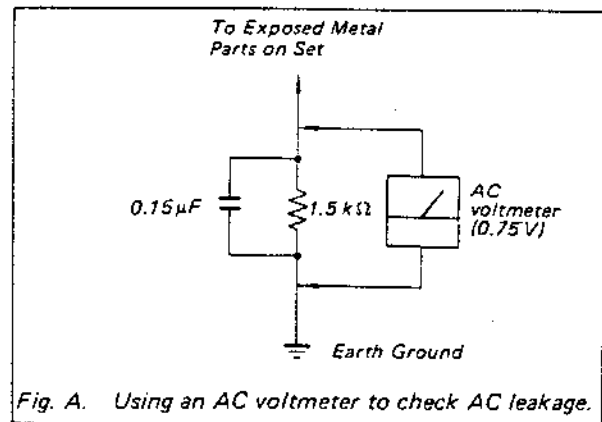
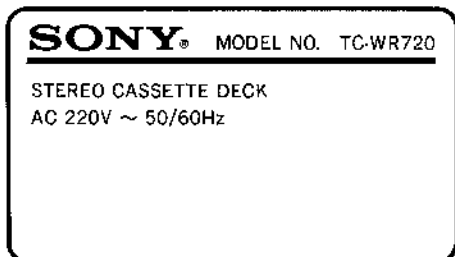

Fig. A. Using an AC voltmeter to check AC leakage.

—MODEL IDENTIFICATION—  
(Specification Label)

TC-W720: AEP, WG (West Germany) model



TC-WR720A: US, Canadian, E model

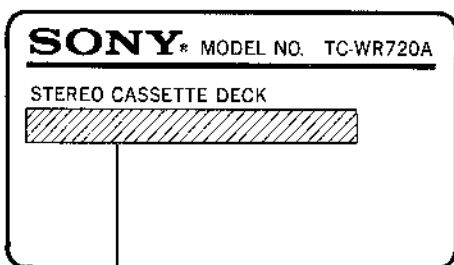

US, Canadian model: AC 120V 60Hz 33W  
E model: AC 120, 220, 240V ~ 50/60Hz 33W

TABLE OF CONTENTS

<u>Section</u>	<u>Title</u>	<u>Page</u>
<b>1. GENERAL</b>		
1-1.	Location and Function of Controls .....	4
<b>2. DISASSEMBLY</b>		
2-1.	Front Panel (WR720A).....	5
2-2.	Mechanism Deck (WR720A) .....	5
2-3.	Front Panel (WR720) .....	6
2-4.	Mechanism Deck (WR720) .....	6
2-5.	Capstan Motor, Reel Motor (1) .....	7
2-6.	Capstan Motor, Reel Motor (2) .....	7
2-7.	Head, Pinch Roller .....	7
<b>3. MECHANICAL ADJUSTMENTS</b>		8
<b>4. ELECTRICAL ADJUSTMENTS</b>		8
<b>5. DIAGRAMS</b>		
5-1.	Circuit Boards Location .....	12
5-2.	Semiconductor Lead Layouts .....	13
5-3.	Printed Wiring Boards —Main Section— .....	14
5-4.	Schematic Diagram —Audio/Power Section— .....	19
5-5.	Schematic Diagram —System Control Section— .....	23
5-6.	Schematic Diagram —Panel Section— .....	27
5-7.	Printed Wiring Boards —Panel Section— .....	28
<b>6. EXPLODED VIEWS</b>		
6-1.	Chassis Section.....	30
6-2.	Front Panel Section (WR720A) .....	31
6-3.	Front Panel Section (WR720) .....	32
6-4.	Mechanism Section-1 .....	33
6-5.	Mechanism Section-2 .....	34
<b>7. ELECTRICAL PARTS LIST</b>		35

SECTION 1  
GENERAL

1-1. LOCATION AND FUNCTION OF CONTROLS

(TC-WR720)

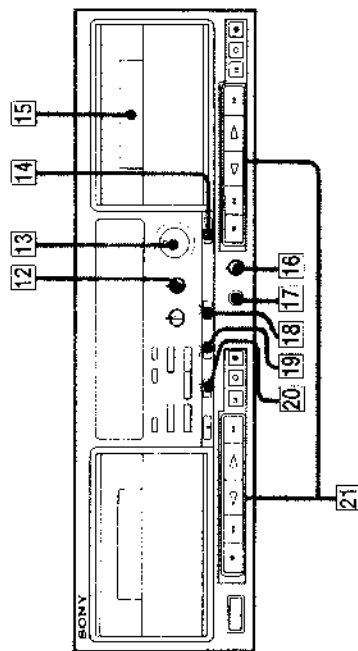
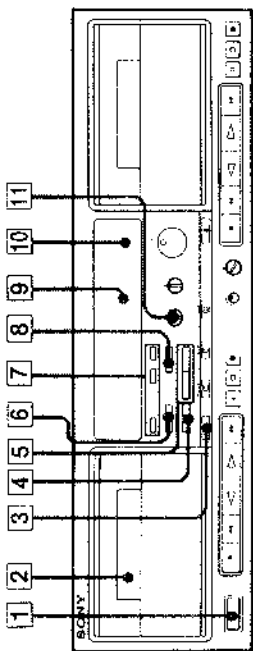

- 1 POWER switch
- 2 Cassette holder (deck A)
- 3 eject button (deck A)
- 4 A + B REC (recording) button and indicator
- 5 SYNCHRO DUBBING buttons  
HIGH SPEED button  
NORM (normal) SPEED button
- 6 BLANK SKIP button
- 7 COUNTER buttons  
RESET button  
A/B (deck A/B) selector
- 8 AUTO PAUSE button
- 9 Display panel
- 10 Remote control sensor  
You can remotely control this cassette deck with a remote commander that came with a Sony amplifier or receiver if it has the mark and cassette deck control capability.  
Any optional Sony remote commander with the mark
- 11 BIAS control (deck B)
- 12 BALANCE control
- 13 REC (recording) LEVEL control
- 14 eject button (deck B)
- 15 Cassette holder (deck B)
- 16 HEADPHONES LEVEL control
- 17 PHONES (headphones) jack (stereo phone jack)
- 18 NR (Dolby noise reduction) switch
- 19 DIR (direction) MODE switch
- 20 TIMER switch
- 21 Tape operation buttons  
■ (stop) button  
◀ (leftward fast winding) button  
◄ (reverse play) button  
▶ (forward play) button  
▲ (rightward fast winding) button  
|| PAUSE button  
○ REC MUTE (record muting) button  
● REC (recording) button

(TC-WR720A)

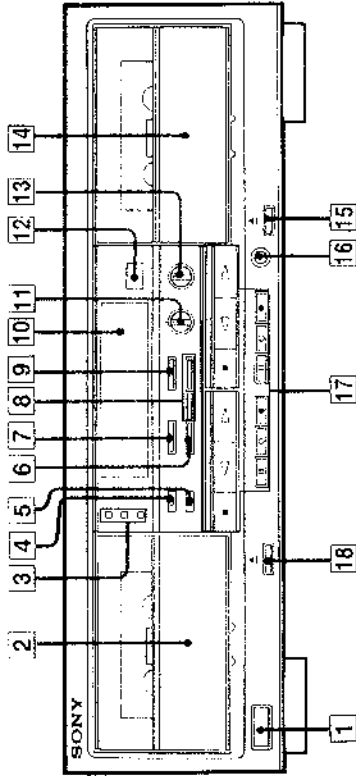

- 1 POWER switch
  - 2 Cassette holder (deck A)
  - 3 Counter buttons  
RESET button  
MEMORY button  
A/B (deck A/B) selector
  - 4 DIR (direction) MODE switch
  - 5 NR (Dolby noise reduction) switch
  - 6 A + B REC (recording) button and indicator
  - 7 BLANK SKIP button
  - 8 SYNCHRO DUBBING buttons  
HIGH SPEED button  
NORM (normal) SPEED button
  - 9 AUTO PAUSE button
  - 10 Display panel
  - 11 BALANCE control
  - 12 Remote control sensor  
You can remotely control this cassette deck with a remote commander that came with a Sony amplifier or receiver if it has the mark and cassette deck control capability.  
Any optional Sony remote commander with the mark
  - 13 REC (recording) LEVEL control
  - 14 Cassette holder (deck B)
  - 15 eject button (deck B)
  - 16 PHONES (headphones) jack (stereo phone jack)
  - 17 Tape operation buttons  
▶▶ (AMS\*) (leftward fast winding) button  
▶ (AMS\*) (leftward fast winding) button  
■ (stop) button  
◄ (reverse play) button  
◄ (reverse play) button  
|| PAUSE button  
○ REC MUTE (record muting) button  
● REC (recording) button
  - 18 eject button (deck A)
- \* AMS is an abbreviation for Automatic Music Sensor

## SECTION 2 DISASSEMBLY

Note: Follow the disassembly procedure in the numerical order given.

### 2-1. FRONT PANEL (WR720A)

- Remove the connector from audio system control board.

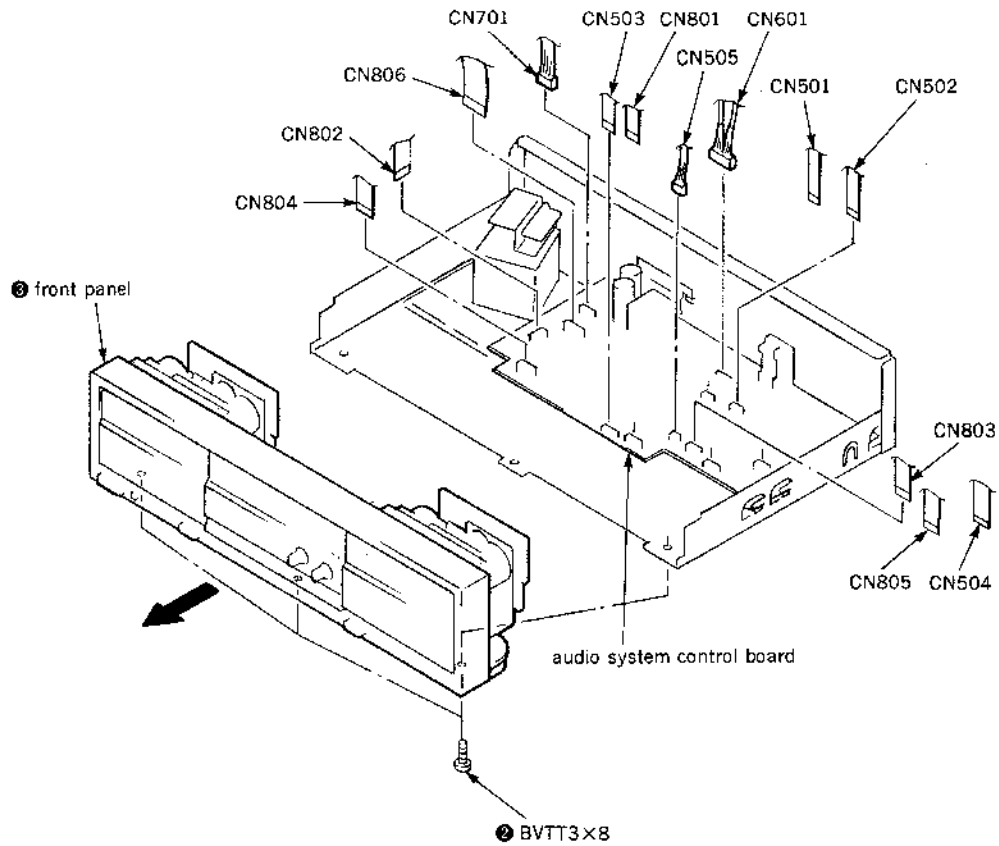

### 2-2. MECHANISM DECK (WR720A)

- Push the EJECT button.

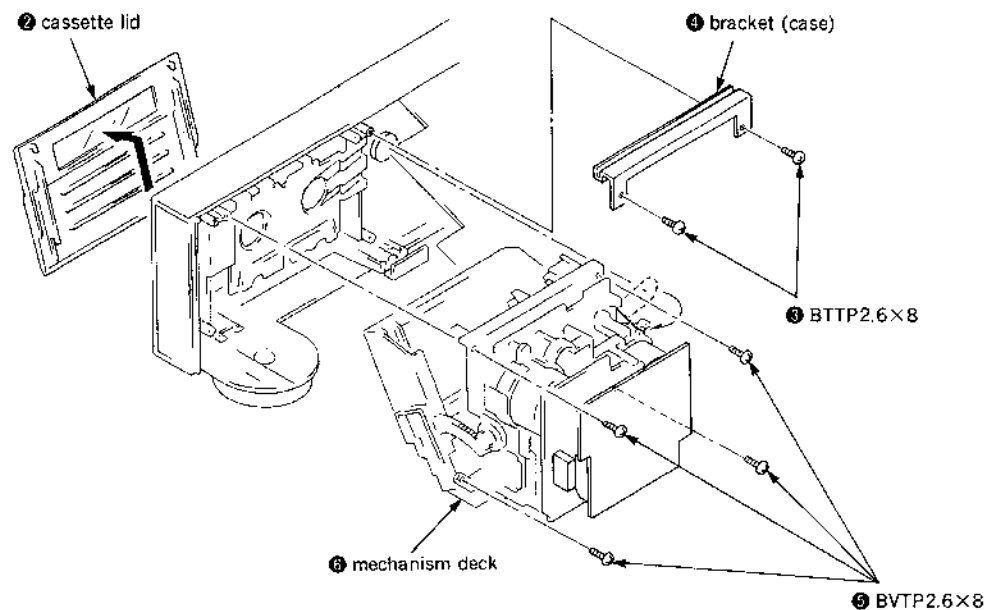

**2-3. FRONT PANEL (WR720)**

- ❶ Remove the connector from audio system control board.
- ❷ Push the EJECT button.

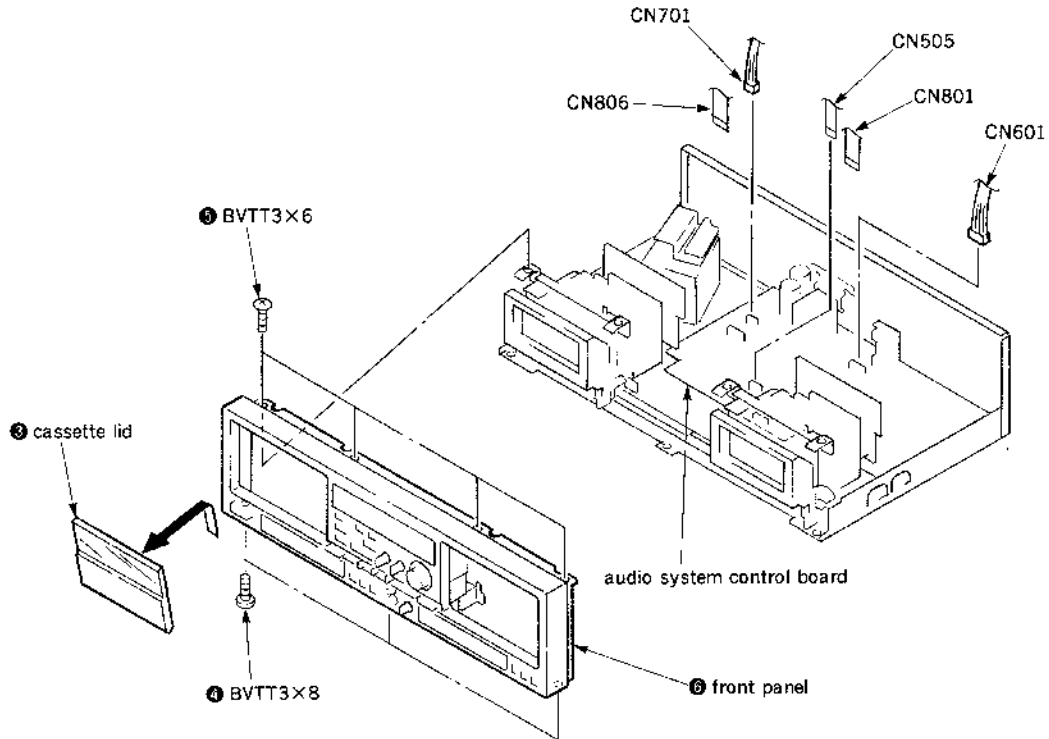

**2-4. MECHANISM DECK (WR720)**

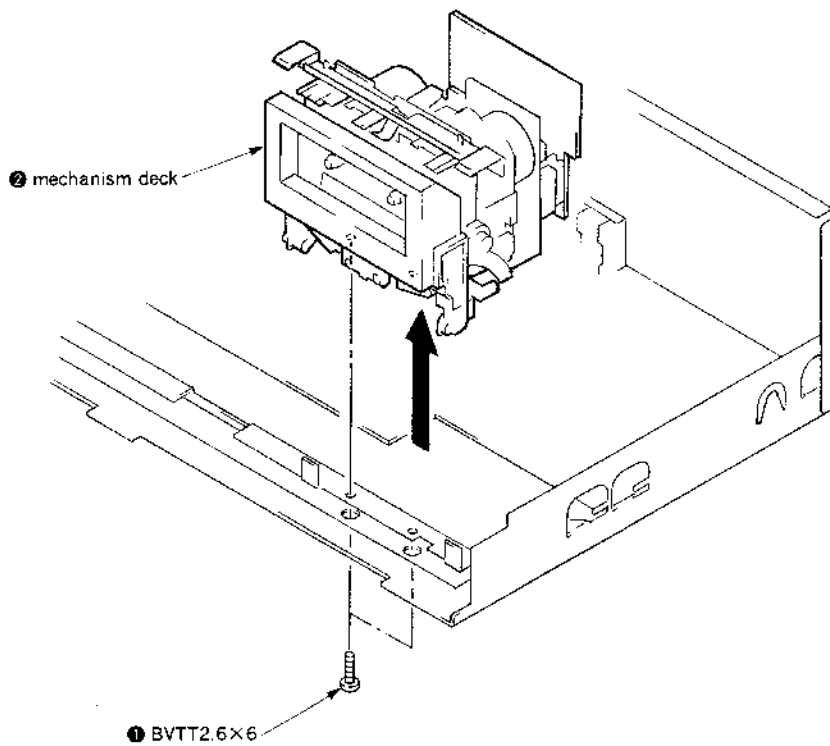

2-5. CAPSTAN MOTOR, REEL MOTOR (1)

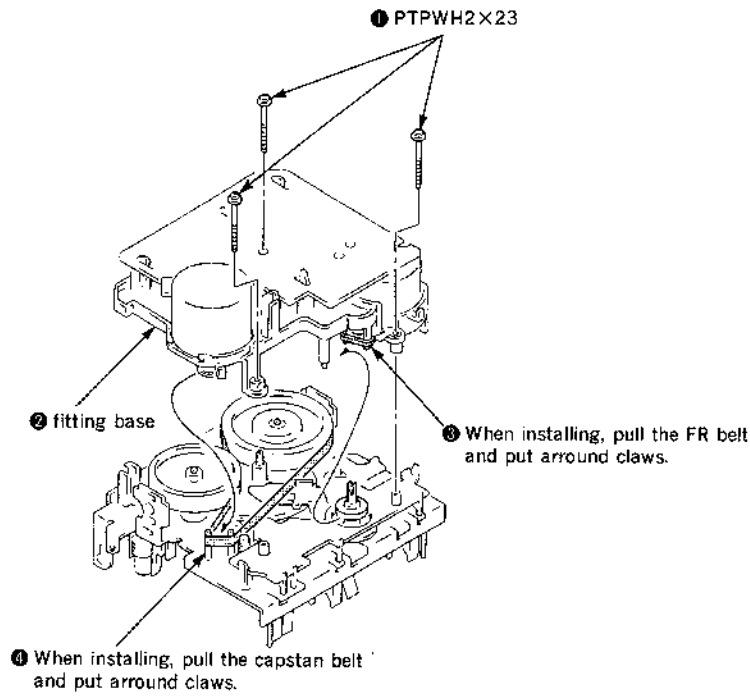

2-6. CAPSTAN MOTOR, REEL MOTOR (2)

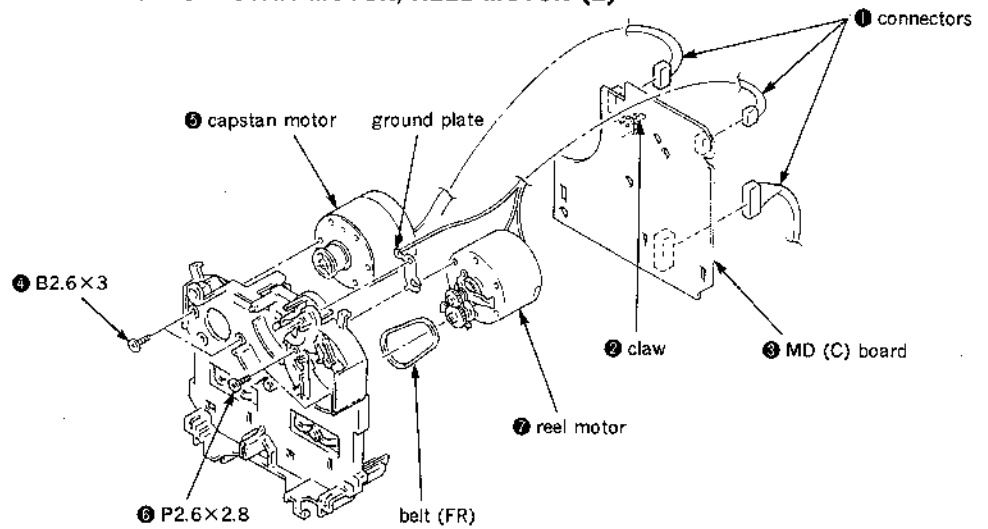

2-7. HEAD, PINCH ROLLER

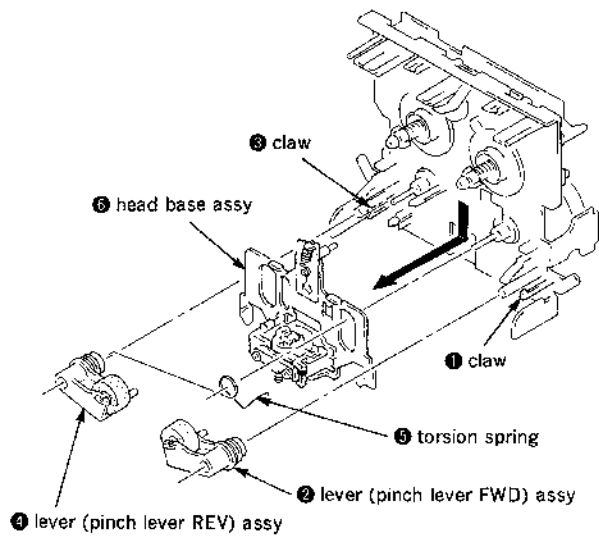

## SECTION 3 MECHANICAL ADJUSTMENTS

### PRECAUTION

1. Clean the following parts with a denatured alcohol-moistened swab:
 

record/playback head	pinch roller
erase head	rubber belts
capstan	idlers
2. Demagnetize the record/playback head with a head demagnetizer.  
(Head demagnetizer do not approach for the erase head.)
3. Do not use a magnetized screwdriver for the adjustment.
4. After the adjustments, apply suitable locking compound to the parts adjusted.
5. The adjustments should be performed with the rated power supply voltage unless otherwise noted.

### Torque Measurement

Torque	Torque meter	Meter reading
Forward	CQ-102C	30 to 65g·cm (0.42 to 0.90 oz·inch)
Forward back tension	CQ-102C	1 to 6g·cm (0.014 to 0.08 oz·inch)
Reverse	CQ-102RC	30 to 65g·cm (0.42 to 0.90 oz·inch)
Reverse back tension	CQ-102RC	1 to 6g·cm (0.014 to 0.08 oz·inch)
Forward, Reverse	CQ-201B	70 to 120g·cm (0.98 to 1.67 oz·inch)

## SECTION 4 ELECTRICAL ADJUSTMENTS

### PRECAUTION

1. The adjustment should be performed in the publication.  
(Be sure to make playback adjustment at first.)
2. The adjustment and measurement should be performed for both L-CH and R-CH.
  - Switch position  
DOLBY NR switch : OFF  
DIR MODE switch : ⇄
  - Standard record position  
Deliver the standard input signal level to input jack and set the REC LEVEL control to obtain the standard output signal level as follows.

—Record Mode—

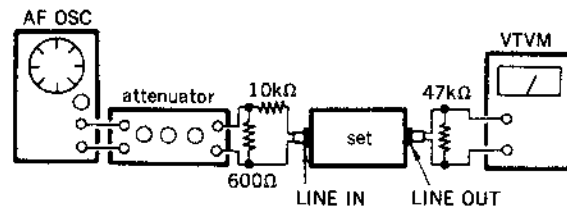

### Standard Input Level

Input terminal	LINE IN
source impedance	10kΩ
input signal level	0.25V (-10dB)

### Standard Output Level

Output terminal	LINE OUT
load impedance	47kΩ
output signal level	0.44V (-5dB)

### Test Tape

Tape	Contents	Use
P-4-A100	10kHz, -10dB	Azimuth Adjustment
P-4-L300	315Hz, 0dB	Level Adjustment
WS-43B	3kHz, 0dB	Tape Speed Adjustment

3. Prior to electrical adjustments, short the connector TP1 (test mode).

audio system control board —component side—

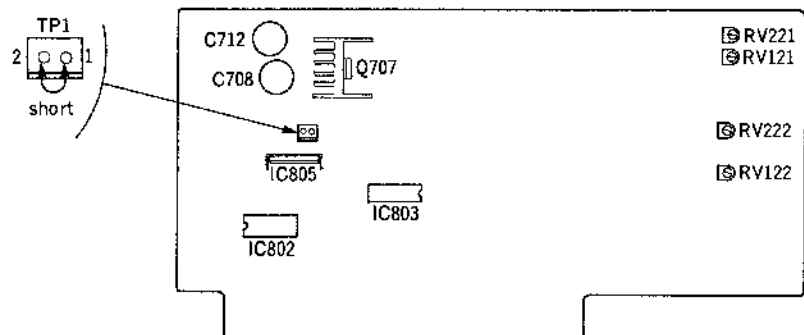



## Record/Playback Head Azimuth Adjustment

**DECK A** **DECK B**

### Procedure :

1. Reverse Playback Mode

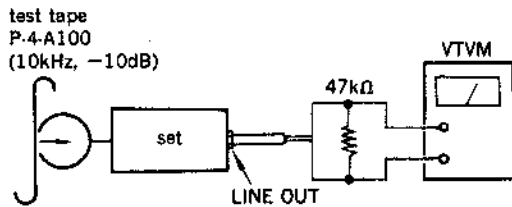

2. Turn the adjustment screw for the maximum output levels. If these levels do not match, turn the adjustment screw until both of output levels match together within 1dB.

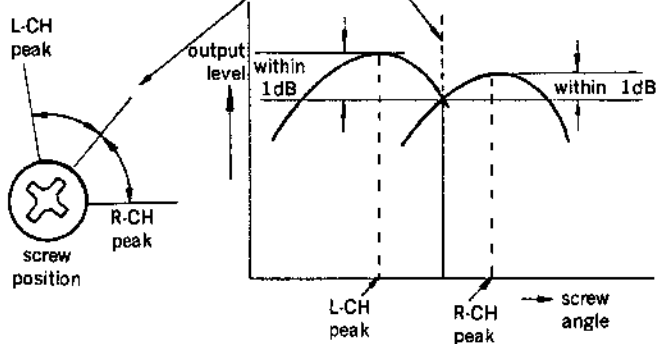

3. Playback Mode

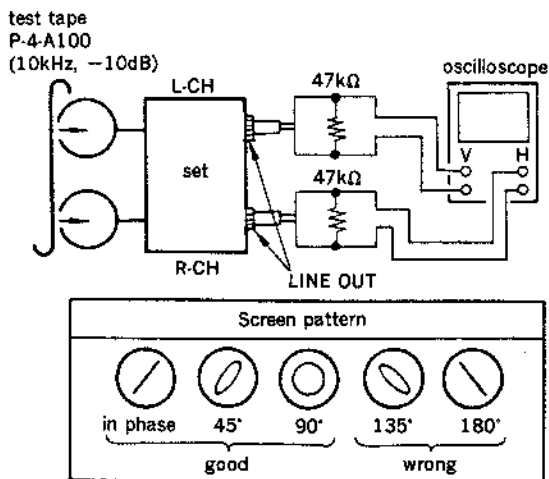

4. Change the forward playback mode and repeat the steps 1 to 3.
5. After the adjustment, lock the adjustment screws with suitable locking compound.

**Adjustment Location :** —record/playback head—

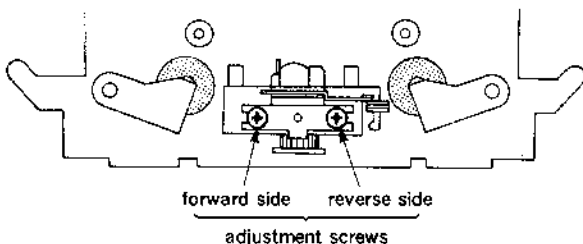

## Tape Speed Adjustment **DECK A** **DECK B**

Perform high speed adjustment before normal speed adjustment.

### Procedure :

—Forward Playback Mode—

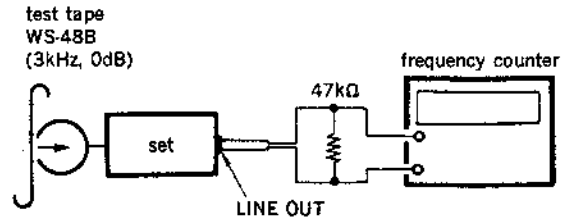

(high speed adjustment)

1. Keep on pressing the SYNCHRO DUBBING HIGH SPEED switch.
2. Confirm that the frequency counter reading becomes within adjustment limits of  $6,000 \pm 60\text{Hz}$  on both of deck A and deck B.
3. If the adjustment limits are not satisfied, adjust each RV72 so that the frequency counter reading becomes within adjustment limits of  $6,000 \pm 30\text{Hz}$  on both of deck A and deck B.
4. Change the reverse playback mode and repeat the steps 1 to 3.

(normal speed adjustment)

5. Keep on pressing the SYNCHRO DUBBING NORM SPEED switch.
6. Confirm that the frequency counter reading becomes within adjustment limits of  $3,000 \pm 30\text{Hz}$  on both of deck A and deck B.
7. If the adjustment limits are not satisfied, adjust each RV71 so that the frequency counter reading becomes within adjustment limits of  $3,000 \pm 15\text{Hz}$  on both of deck A and deck B.
8. Change the reverse playback mode and repeat the steps 5 to 7.

Frequency difference between the beginning and the end of the tape should be within 3%.

Frequency difference between deck A and deck B the beginning of the tape should be within 1.5%.

**Adjustment Location :** MD (C) board (deck A, deck B)

## Playback Level Adjustment DECK A DECK B

### Procedure :

—Forward Playback Mode—

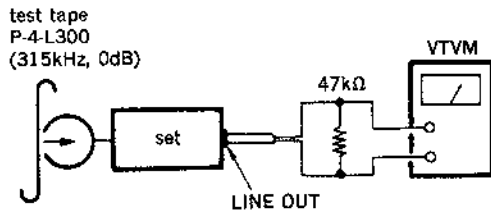

Adjust each RV11 (L-CH) and RV21 (R-CH) so that the VTVM reading becomes within adjustment limits below on both of deck A and deck B.

### Adjustment Limits :

LINE OUT level :  $-15 \pm 0.5\text{dB}$  (0.130 to 0.146V)

Level difference between channels : within 0.5dB

Confirm the LINE OUT level does not change in playback mode while changing the mode from playback to stop several times.

**Adjustment Location :** MD(C) board (deck A, deck B)

## Bias Consumption Current Adjustment

### DECK A DECK B

This adjustment should be performed when replacing the head assy or step-up transformer (T0391, 0491 (deck A) and T391, 491 (deck B)), or DOLBY HX-PRO IC (IC0691 (deck A) and IC691 (deck B)).

### Procedure :

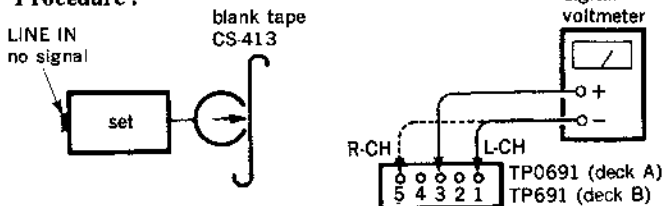

(deck A)

1. Connect the digital voltmeter to test point TP0691.
2. Set RV0391 (L-CH) and RV0491 (R-CH) to mechanical center.
3. Set to forward record mode.
4. Adjust T0391 (L-CH) and T0491 (R-CH) so that the digital voltmeter reading becomes minimum.

(deck B)

5. Similarly, connect the digital voltmeter to test point TP691.
6. Set RV391 (L-CH) and RV491 (R-CH) to mechanical center.
7. Set to forward record mode.
8. Adjust T391 (L-CH) and T491 (R-CH) so that the digital voltmeter reading becomes minimum.

**Adjustment Location :** HX-PRO board (A) (deck A),  
HX-PRO board (B) (deck B)

## Record Bias Adjustment DECK A DECK B

### Setting :

REC LEVEL control: standard record position (Refer to page 8.)

### Procedure :

1. Record Mode

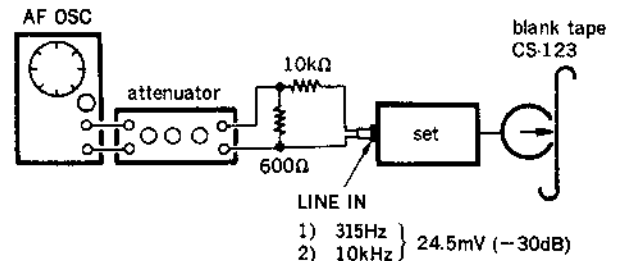

2. Playback Mode

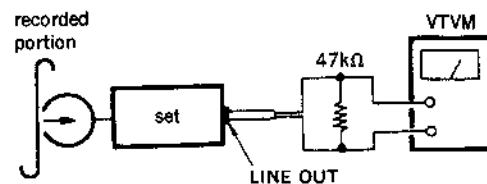

(deck A)

3. Playback the signal recorded in step 1, and confirm that the 10kHz playback output level is VTVM reading becomes within adjustment limits below relative to the 315Hz output.
4. If the adjustment limits are not satisfied, adjust each RV0391 (L-CH) and RV0491 (R-CH) so that the VTVM reading becomes within adjustment limits on next page.

(deck B)

5. Similarly, playback the signal recorded in step 1, and confirm that the 10kHz playback output level is VTVM reading becomes within adjustment limits below relative to the 315Hz output.
6. If the adjustment limits are not satisfied, adjust each RV391 (L-CH) and RV491 (R-CH) so that the VTVM reading becomes within adjustment limits on next page.

**Adjustment Limits :**

10kHz playback output  
relative to the 315Hz output :  $0 \pm 0.5\text{dB}$   
(0.732 to 0.821V)

**Adjustment Location :** audio system control board

**Record Level Adjustment** DECK A DECK B

**Setting :**

REC LEVEL control : standard record position (Refer to page 8.)

**Procedure :**

1. Record Mode

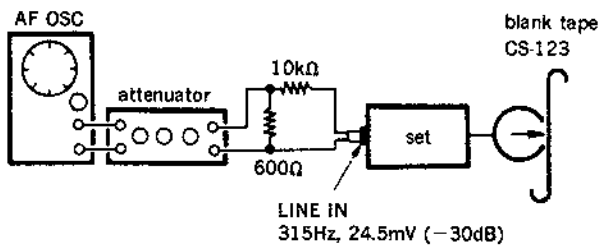

2. Playback Mode

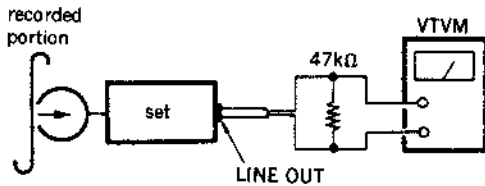

(deck A)

3. Playback the signal recorded in step 1, and confirm that the 10kHz playback output level is VTVM reading becomes within adjustment limits below relative to the 315Hz output.

4. If the adjustment limits are not satisfied, adjust each RV121 (L-CH) and RV221 (R-CH) so that the VTVM reading becomes within adjustment limits below.

(deck B)

5. Similarly, playback the signal recorded in step 1, and confirm that the 10kHz playback output level is VTVM reading becomes within adjustment limits below relative to the 315Hz output.

6. If the adjustment limits are not satisfied, adjust each RV122 (L-CH) and RV222 (R-CH) so that the VTVM reading becomes within adjustment limits below.

**Adjustment Limits :**

315Hz playback output level :  $-25 \pm 0.5\text{dB}$  (42 to 46mV)

**Adjustment Location :** audio system control board

**Note :** After adjustment, open the connector TP1.

**—Adjustment Parts Location Diagrams—**

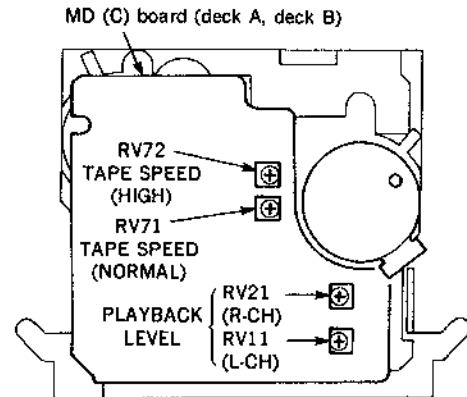

HX-PRO board (A) (deck A),  
HX-PRO board (B) (deck B)

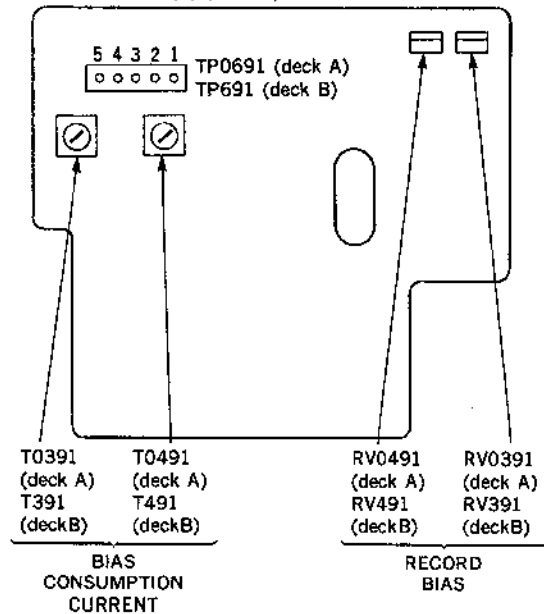

RECORD LEVEL  
(deck A)

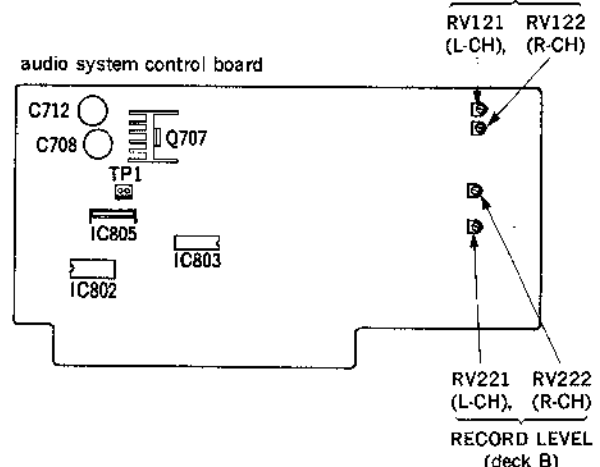

**SECTION 5  
DIAGRAMS**

**5-1. CIRCUIT BOARDS LOCATION  
(TC-WR720A)**

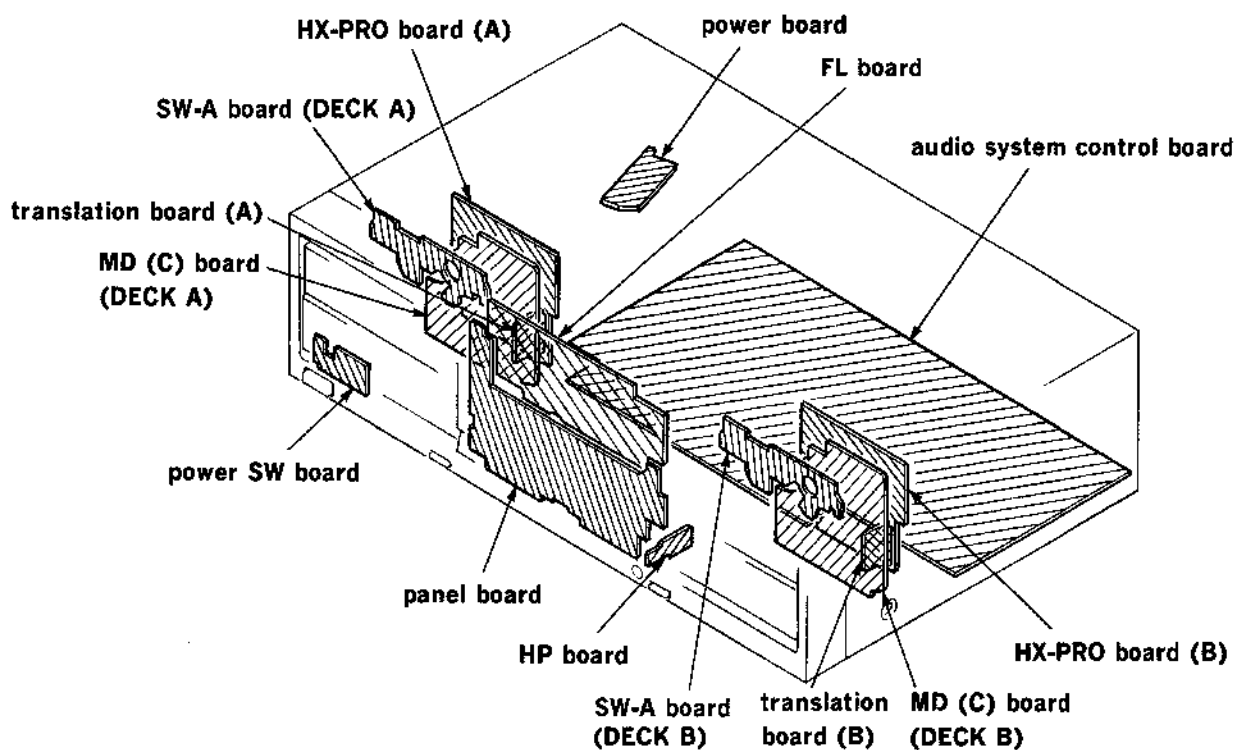

**(TC-WR720)**

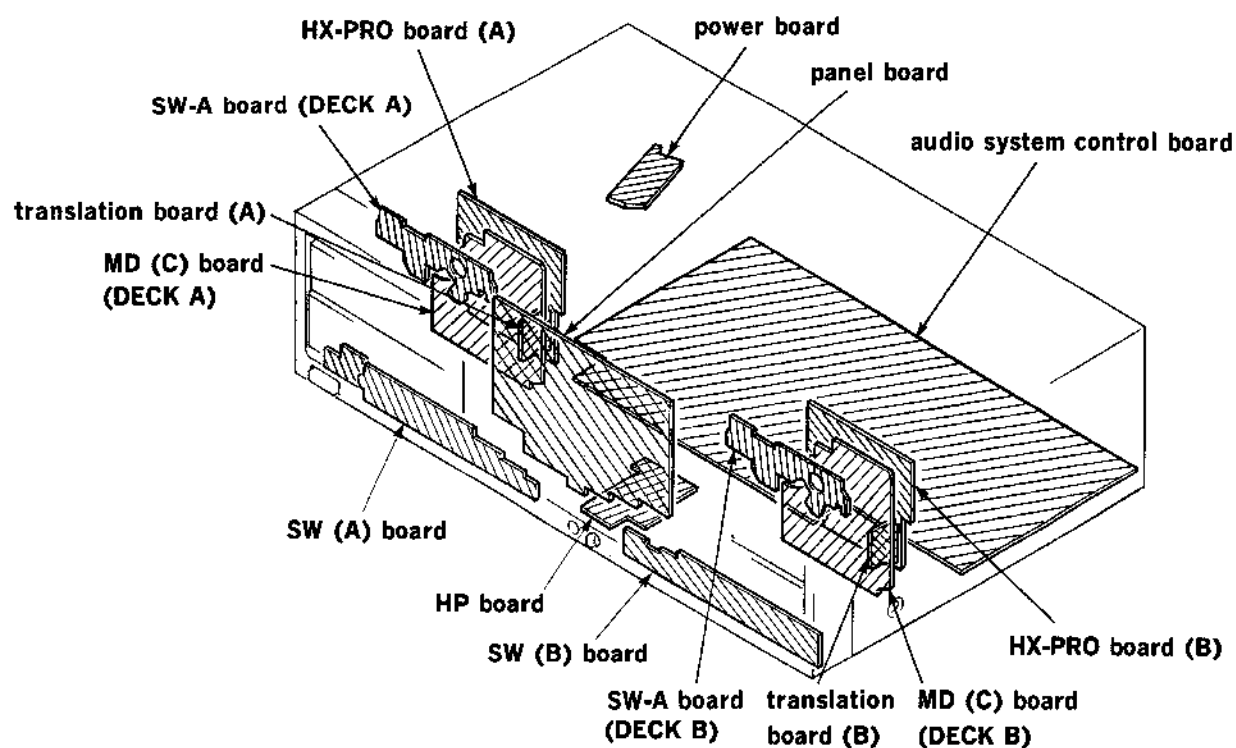

**5-2. SEMICONDUCTOR LEAD LAYOUTS**

DTA114ES  
DTA144ES  
DTC114ES  
DTC143TS  
DTC144ES  
DTC144WS  
2SC2603-EF  
2SD1012-FG



2SA1317-S  
2SA1317-STU  
2SB1013-4  
2SC945-P



2SB1187-EF



2SD1761-EF



GP-2S09-C

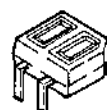

HZS6A1L  
HZS9A2L  
UZL-11L2  
UZL-7H1  
UZL-7L2  
1SS202-1

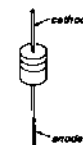

10E2N

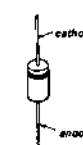

SEL2210S

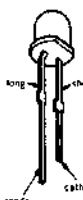

**● Semiconductor Location**

Ref. No.	Location	Ref. No.	Location
D31	C-4	Q51	B-4
D131	E-22	Q52	B-4
D231	F-22	Q53	C-4
D501(*1)	D-22	Q71	B-4
D502	D-22	Q101	D-23
D503	D-22	Q102(*1)	D-23
D571	E-23	Q121	C-19
D572	E-23	Q171	E-21
D601	D-28	Q201	B-23
D602	E-28	Q202(*1)	B-23
D701	D-28	Q221	B-19
D702	D-29	Q271	F-21
D703	D-30	Q501	E-23
D704	B-30	Q502	D-22
D705	B-30	Q503(*1)	D-22
D706	D-31	Q504	D-21
D707	C-30	Q505	D-21
D708	C-30	Q521	F-22
D709	C-27	Q551	F-22
D710	C-30	Q552	E-19
D711	C-30	Q553	D-19
D712	C-28	Q571	F-23
D713	D-30	Q572	F-23
D801	F-25	Q601	G-24
D811	H-29	Q701	B-29
D812	H-29	Q702	B-29
D902(*2)	C-13	Q703	D-29
IC31	D-3	Q704	D-30
IC81	G-4	Q705	B-28
IC501	C-22	Q706	C-26
IC503	F-24	Q707	C-28
IC504	E-22	Q708	C-26
IC506	D-24	Q801	G-20
IC509	E-19	Q802	H-30
IC510	F-21	Q803	H-29
IC551	C-19	Q804	H-29
IC601(*2)	E-21	Q805	E-28
IC691	G-8	Q806	F-27
IC701	C-27	Q807	F-25
IC802	F-29	Q851	H-27
IC803	F-27	Q852	H-28
IC804	F-28	Q853	G-26
IC805	E-29	Q854	G-27
IC806	G-27	Q891	G-25
IC807	G-28	Q901(*2)	D-17
IC901(*2)	D-14	Q902(*2)	D-16
IC902(*2)	D-17	Q903(*2)	D-16
IC0691	B-8	Q904(*2)	D-13

\* 1: Used on TC-WR720 only.

\* 2: Used on TC-WR720A only.

5-3. PRINTED WIRING BOARDS —MAIN SECTION— • Refer to page 13 for Semiconductor Lead Layouts and Semiconductor Location.

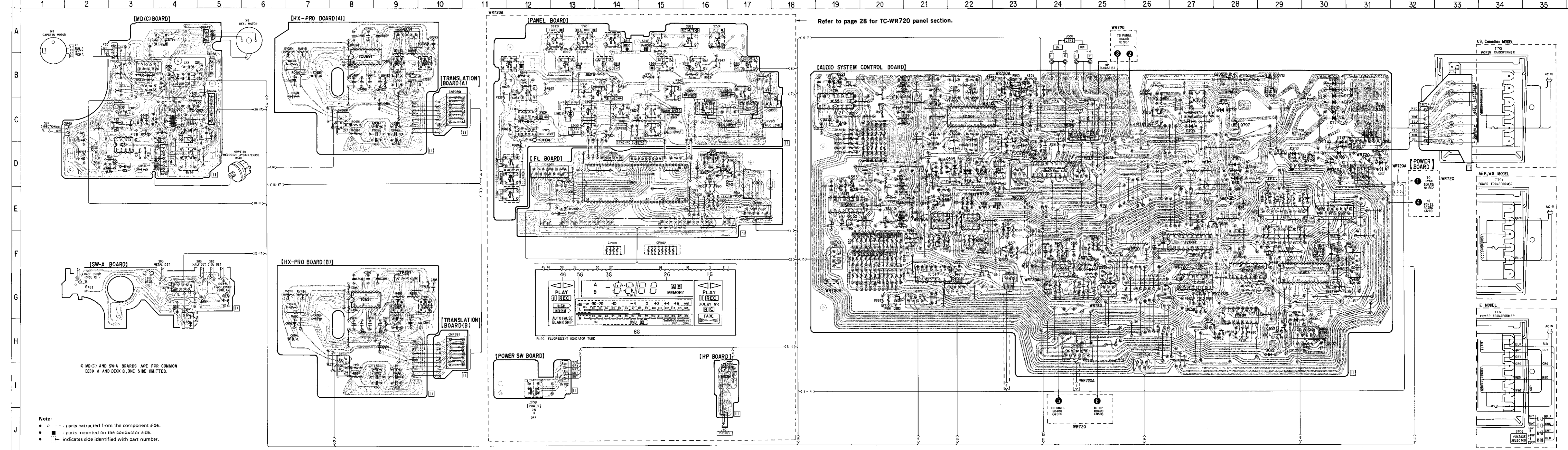

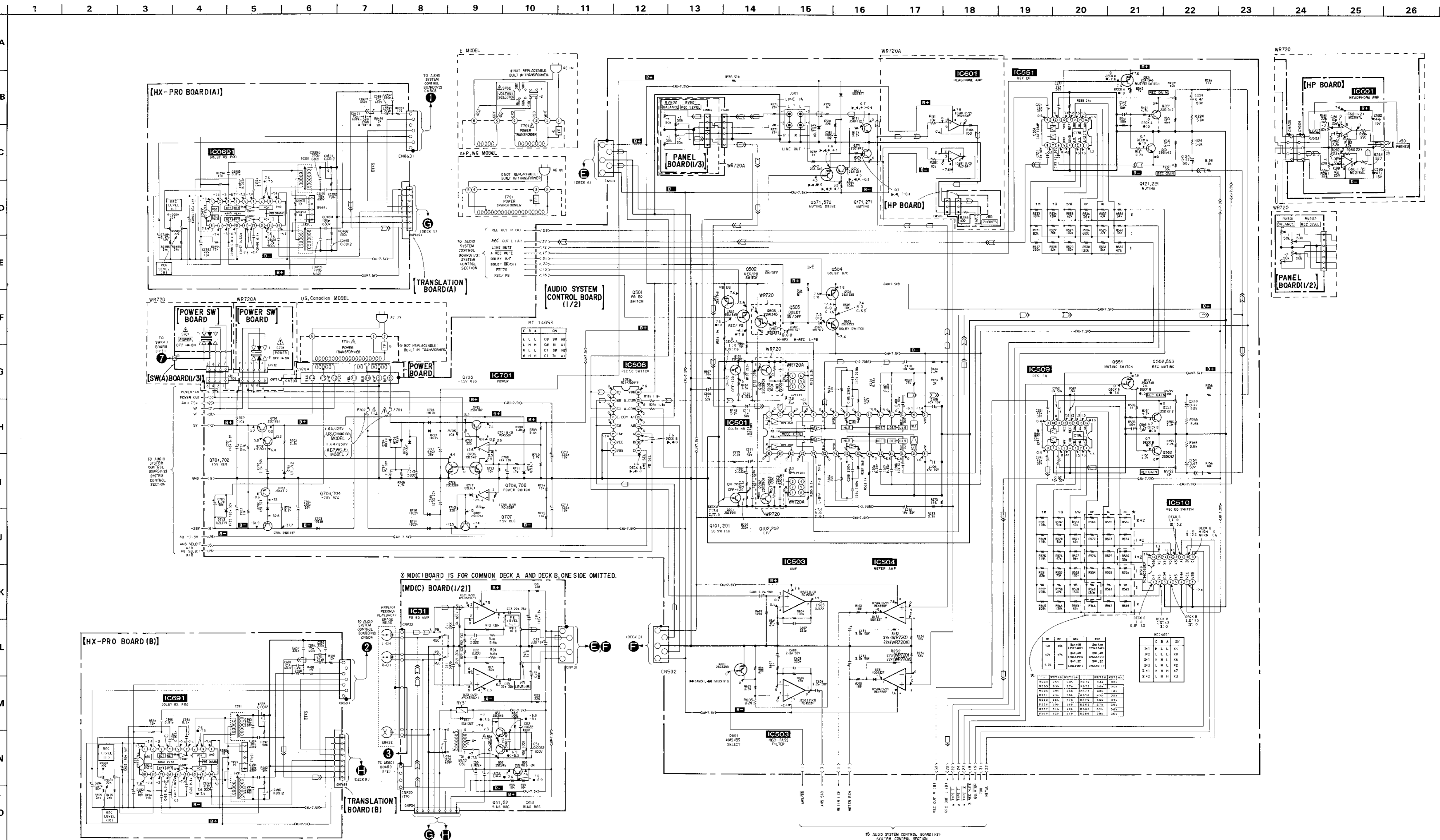

• IC Block Diagrams

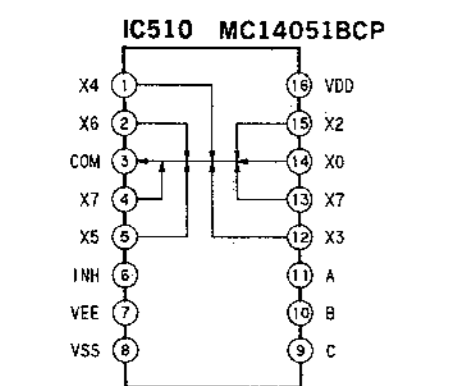
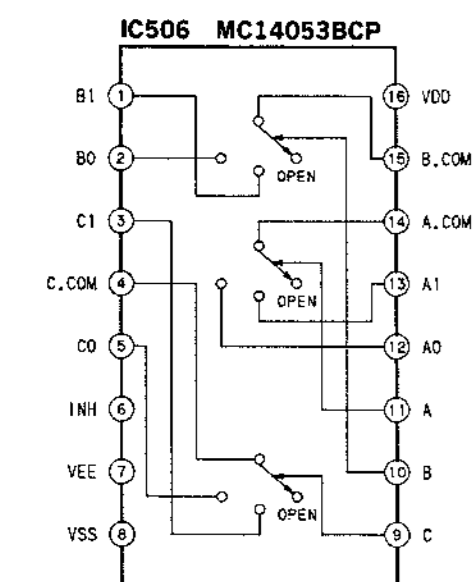

- Note:**
- All capacitors are in  $\mu\text{F}$  unless otherwise noted. pF:  $\mu\text{pF}$  50WV or less are not indicated except for electrolytics and tantalums.
  - All resistors are in  $\Omega$  and  $\frac{1}{2}W$  or less unless otherwise specified.
  - : fusible resistor.
- Note:** The components identified by mark or dotted line with mark are critical for safety. Replace only with part number specified.
- Note:** Les composants identifiés par une marque ou pointillés sont critiques pour la sécurité. Ne les remplacer que par une pièce portant le numéro spécifié.
- : adjustment for repair.
  - Voltage is dc with respect to ground under no-signal conditions.
  - no mark: POWER ON
  - : FWD : REV
  - : FF : REW
  - : REC
  - Voltages are taken with a VOM (Input Impedance 10M $\Omega$ ). Voltage variations may be noted due to normal production tolerances.
  - Signal path.
  - : PB (DECK A)
  - : REC (DECK A)
  - : PB (DECK B)
  - : REC (DECK B)

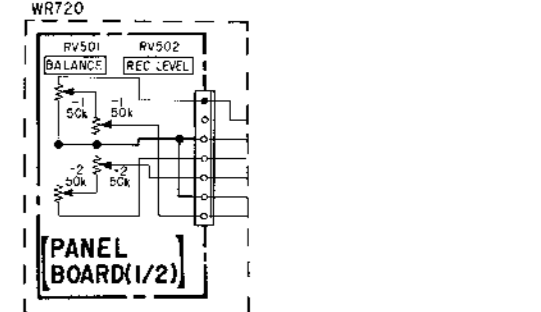
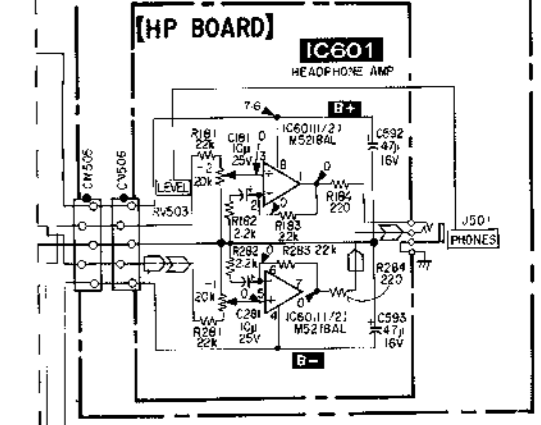

\* MDIC BOARD IS FOR COMMON DECK A AND DECK B, ONE SIDE OMITTED.

RES	VAL	RES	VAL	RES	VAL	RES	VAL
R001	10K	R002	10K	R003	10K	R004	10K
R005	10K	R006	10K	R007	10K	R008	10K
R009	10K	R010	10K	R011	10K	R012	10K
R013	10K	R014	10K	R015	10K	R016	10K
R017	10K	R018	10K	R019	10K	R020	10K
R021	10K	R022	10K	R023	10K	R024	10K
R025	10K	R026	10K	R027	10K	R028	10K
R029	10K	R030	10K	R031	10K	R032	10K
R033	10K	R034	10K	R035	10K	R036	10K
R037	10K	R038	10K	R039	10K	R040	10K
R041	10K	R042	10K	R043	10K	R044	10K
R045	10K	R046	10K	R047	10K	R048	10K
R049	10K	R050	10K	R051	10K	R052	10K
R053	10K	R054	10K	R055	10K	R056	10K
R057	10K	R058	10K	R059	10K	R060	10K
R061	10K	R062	10K	R063	10K	R064	10K
R065	10K	R066	10K	R067	10K	R068	10K
R069	10K	R070	10K	R071	10K	R072	10K
R073	10K	R074	10K	R075	10K	R076	10K
R077	10K	R078	10K	R079	10K	R080	10K
R081	10K	R082	10K	R083	10K	R084	10K
R085	10K	R086	10K	R087	10K	R088	10K
R089	10K	R090	10K	R091	10K	R092	10K
R093	10K	R094	10K	R095	10K	R096	10K
R097	10K	R098	10K	R099	10K	R100	10K

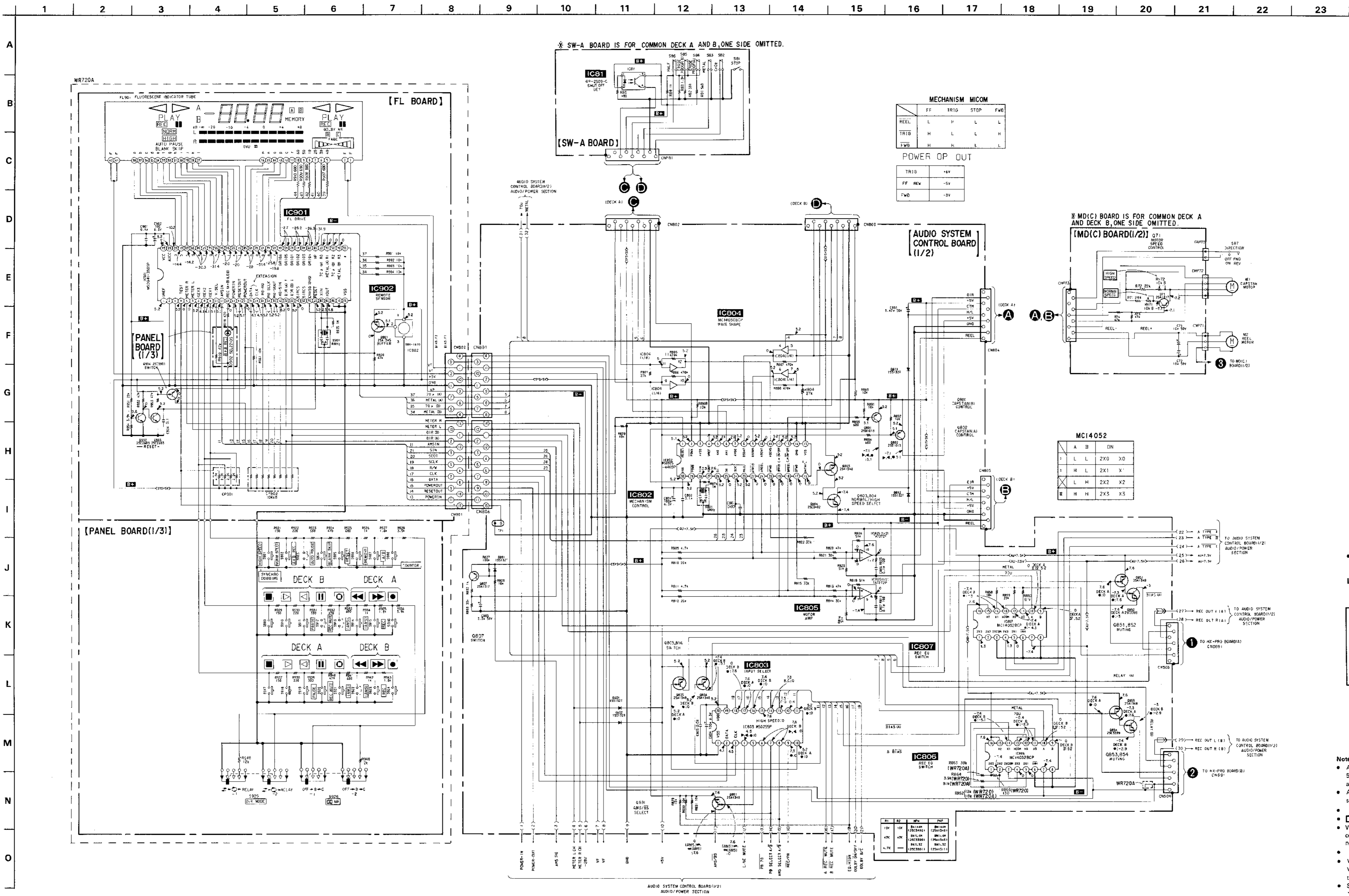

5-6. SCHEMATIC DIAGRAM —PANEL SECTION—

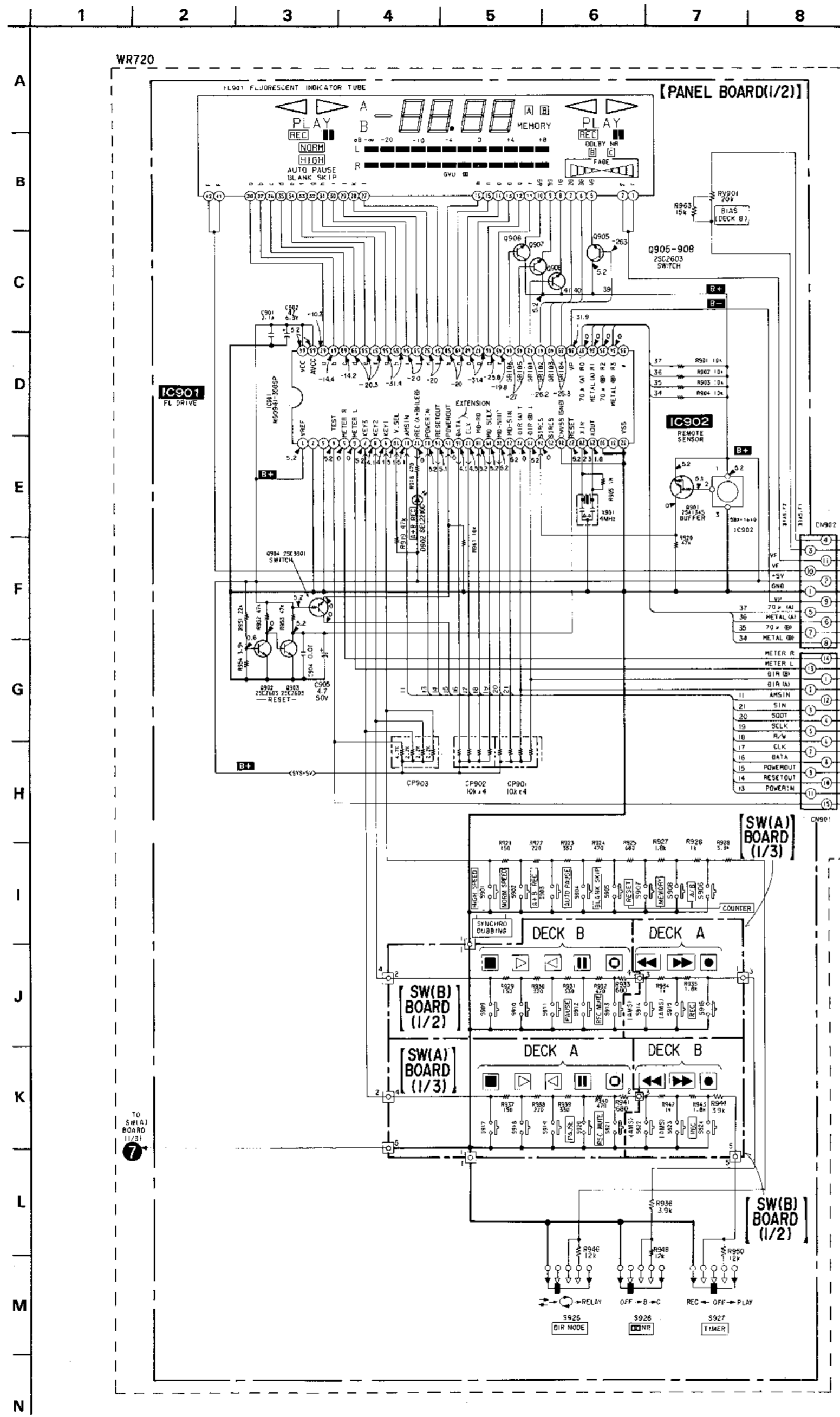

**Note:**

- All capacitors are in  $\mu\text{F}$  unless otherwise noted. pF:  $\mu\text{F}$  50WV or less are not indicated except for electrolytics and tantalums.
- All resistors are in  $\Omega$  and  $1/4\text{W}$  or less unless otherwise specified.
- $\Delta$  : internal component.
- Voltage is dc with respect to ground under no-signal conditions.
- no mark: POWER ON
- Voltages are taken with a VOM (Input Impedance  $10\text{M}\Omega$ ). Voltage variations may be noted due to normal production tolerances.

5-7. PRINTED WIRING BOARDS —PANEL SECTION—

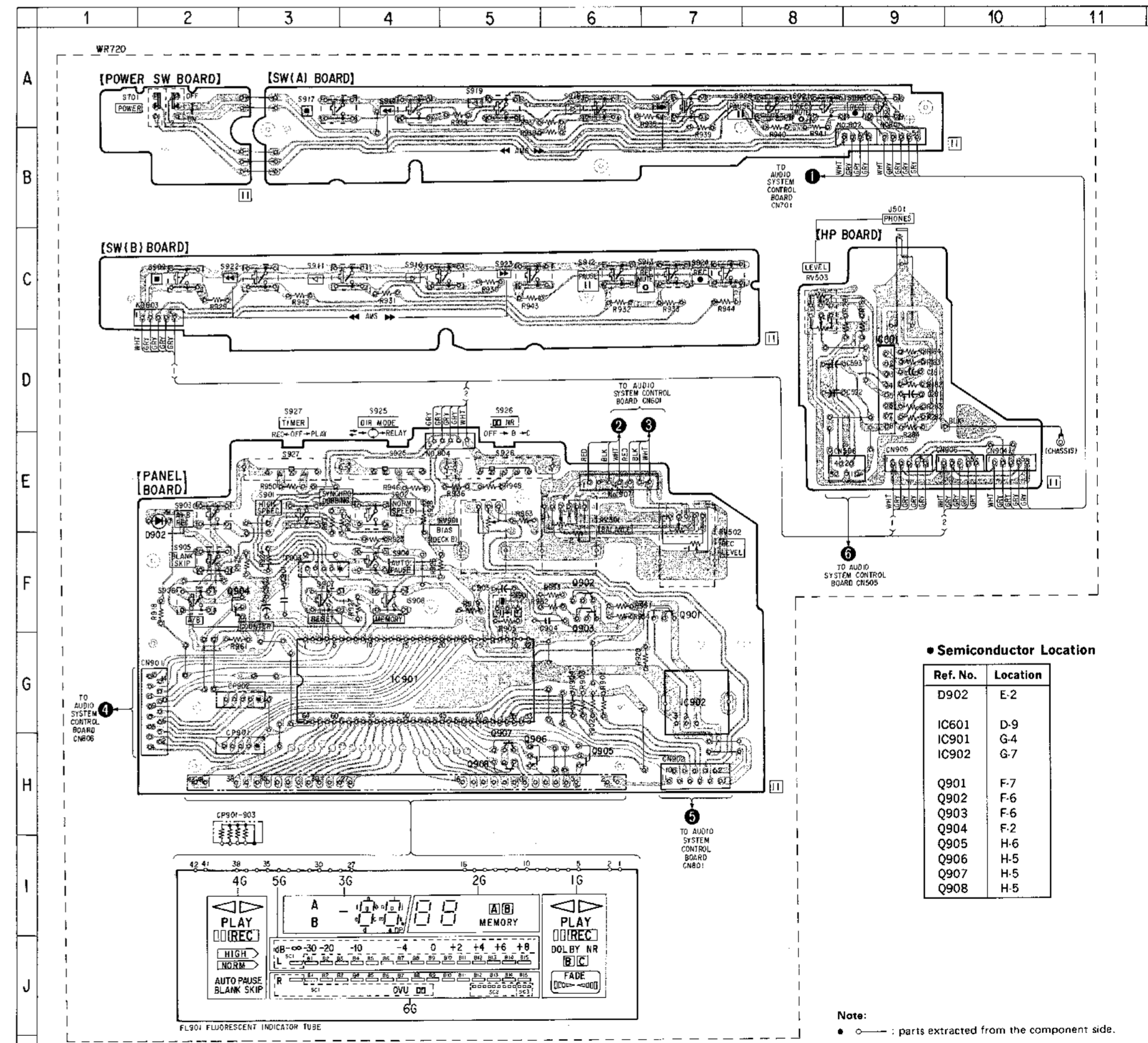



## SECTION 6 EXPLODED VIEWS

**NOTE:**

- The mechanical parts with no reference number in the exploded views are not supplied.
- The construction parts of an assembled part are indicated with a collation number in the remark column.
- Items marked "★" are not stocked since they are seldom required for routine service. Some delay should be anticipated when ordering these items.

- Due to standardization, parts with part number suffix -XX and -X may be different from the parts specified in the components used on the set.
- Color Indication of Appearance Parts  
Example:  
(RED) ... KNOB, BALANCE (WHITE)  
↑ Cabinet's Color                      ↑ Parts' Color
- WG... West Germany model.

The components identified by mark ▲ or dotted line with mark ▲ are critical for safety. Replace only with part number specified.

Les composants identifiés par une marque ▲ sont critiques pour la sécurité. Ne les remplacer que par une pièce portant le numéro spécifié.

### 6-1. CHASSIS SECTION

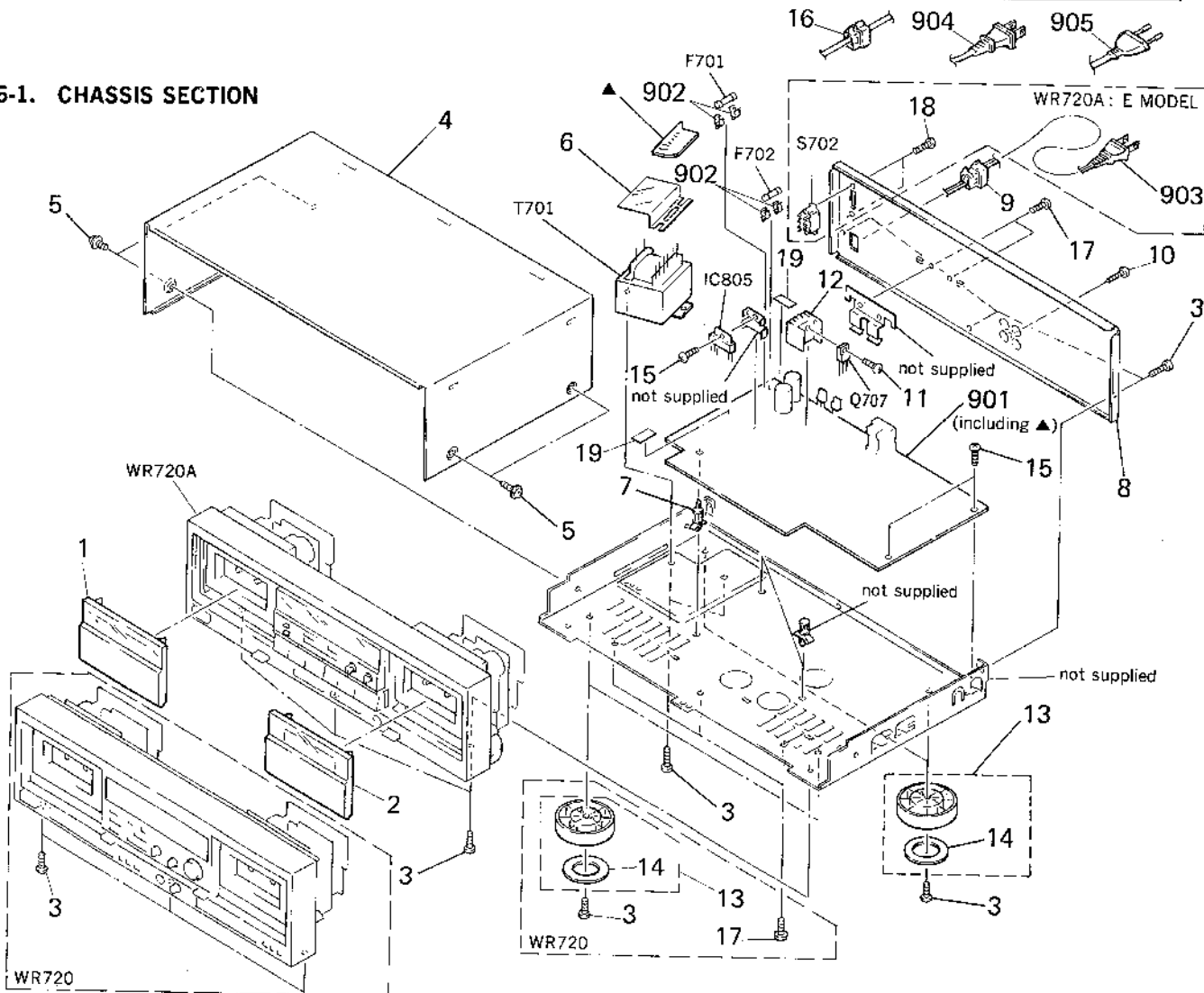

Ref.No	Part No.	Description	Remarks
1	X-3346-323-1	(WR720)...LID (A) ASSY, CASSETTE	
1	X-3362-043-1	(WR720A)...LID (A) ASSY, CASSETTE	
2	X-3346-324-1	(WR720)...LID (B) ASSY, CASSETTE	
2	X-3362-044-1	(WR720A)...LID (B) ASSY, CASSETTE	
3	7-682-548-09	SCREW +BVTT 3X8 (S)	
4	*4-929-294-42	CASE	
5	3-704-366-01	SCREW (CASE) (M3X8)	
6	*3-337-136-11	COVER, TRANSFORMER SAFETY	
7	*3-346-265-11	HOLDER, PC BOARD	
8	*3-354-920-31	(WR720)...PANEL, BACK	
8	*3-354-947-01	(US, Canadian)...PANEL, BACK	
8	*3-354-947-21	(E)...PANEL, BACK	
9	*3-703-571-11	(WR720A)...BUSHING (S) (4516), CORD	
10	7-621-849-00	SCREW, TAPPING	
11	7-685-646-79	SCREW +BVTP 3X8 TYPE2 IT-3	
12	4-363-147-00	HEAT SINK, H.PIN	
13	X-3304-938-2	(AEP, WG, E)...FOOT ASSY	14
13	X-4885-950-1	(US, Canadian)...FOOT ASSY	14
14	4-923-836-11	CUSHION	
15	7-682-547-04	SCREW +BVTT 3X6	
16	3-703-244-00	(WR720)...BUSHING (2104), CORD	
17	7-682-547-09	SCREW +BVTT 3X6	

Ref.No	Part No.	Description	Remarks
18	7-685-534-19	(E)...SCREW +BTP 2.6X8 TYPE2 N-S	
19	*3-701-947-13	(AEP, WG, E)...LABEL (T1.6A), FUSE	
901	*A-2006-254-A	(WR720A)...MOUNTED PCB, AUDIO SYSTEM CONTROL	
901	*A-2006-258-A	(WR720)...MOUNTED PCB, AUDIO SYSTEM CONTROL	
902	*1-533-213-31	HOLDER, FUSE	
903	▲1-551-188-XX	(E)...CORD, POWER	
904	▲1-551-506-XX	(US, Canadian)...CORD, POWER	
905	▲1-555-795-00	(AEP, WG)...CORD, POWER, EULO PLUG	
F701	▲1-532-259-00	(AEP, WG, E)...FUSE, TIME-LAG (T1.6A/250V)	
F701	▲1-532-742-11	(US, Canadian)...FUSE, GLASS TUBE (1.6A/125V)	
F702	▲1-532-259-00	(AEP, WG, E)...FUSE, TIME-LAG (T1.6A/250V)	
F702	▲1-532-742-11	(US, Canadian)...FUSE, GLASS TUBE (1.6A/125V)	
IC805	8-759-207-05	IC TA7272P	
Q707	8-729-920-98	TRANSISTOR 2SD1761-EF	
S702	▲1-570-307-11	(E)...SWITCH, VOLTAGE CHANGE (VOLTAGE SELECTOR)	
T701	▲1-450-147-11	(US, Canadian)...TRANSFORMER, POWER	
T701	▲1-450-148-11	(AEP, WG)...TRANSFORMER, POWER	
T701	▲1-450-191-11	(E)...TRANSFORMER, POWER	

**6-2. FRONT PANEL SECTION  
(WR720A)**

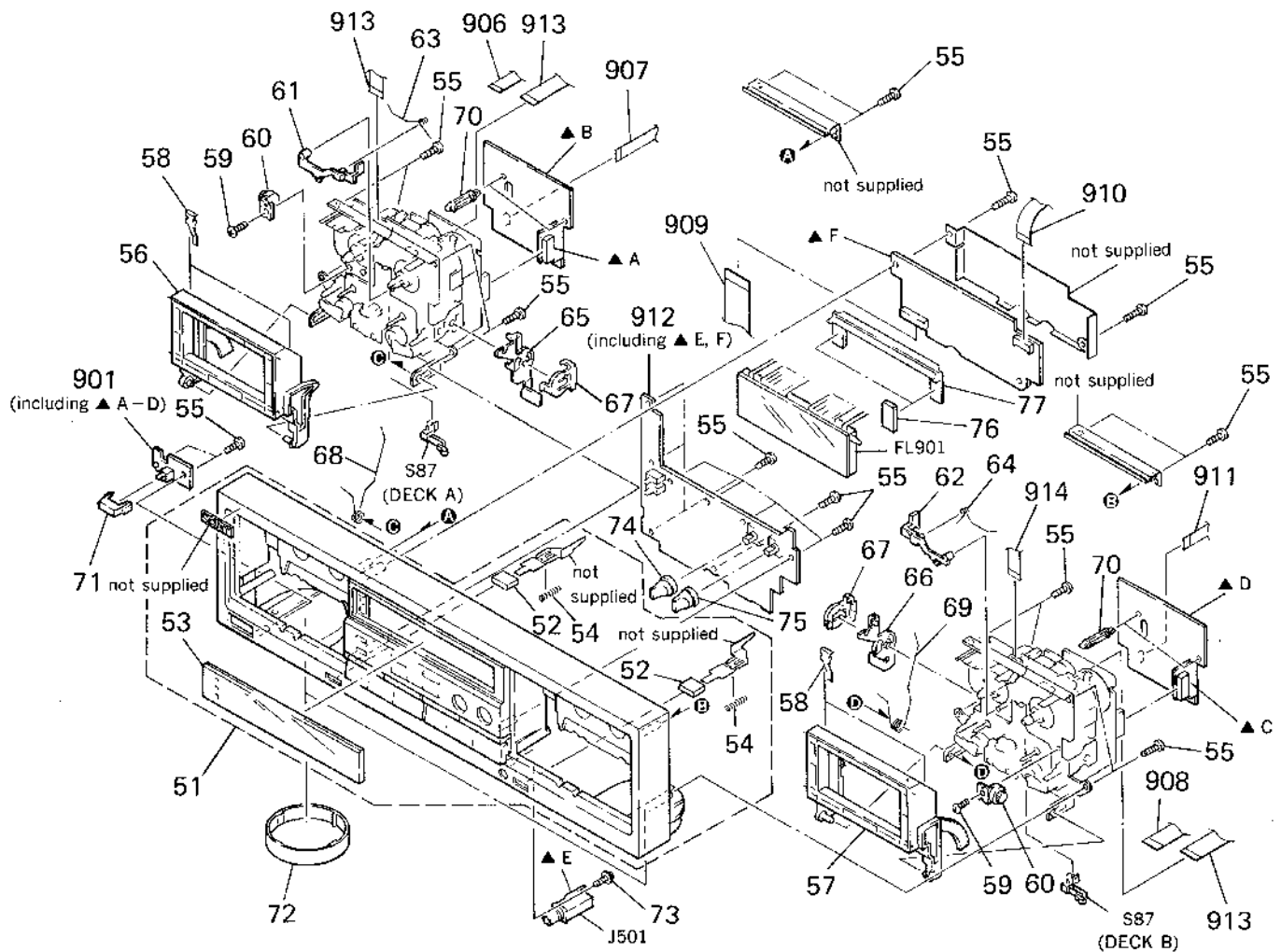

Ref.No	Part No.	Description	Remarks
51	X-3346-310-1	(US, Canadian) ... PANEL ASSY, FRONT	52-54
51	X-3346-322-1	(E) ... PANEL ASSY, FRONT	52-54
52	3-340-188-11	BUTTON (EJECT)	
53	3-359-922-01	(US, Canadian) ... WINDOW (METER)	
53	3-359-922-11	(E) ... WINDOW (METER)	
54	3-500-131-00	SPRING (EJECT SAFETY SPRING R)	
55	4-928-635-01	SCREW, +BV (2.6X8) TAPPING	
56	X-3340-195-1	HOLDER (R) ASSY, CASSETTE	58
57	X-3340-194-1	HOLDER (L) ASSY, CASSETTE	58
58	3-308-823-11	SPRING	
59	7-621-773-95	SCREW +BVTT 2.6X6 (S)	
60	3-354-963-01	DAMPER	
61	3-354-956-01	LEVER (EJECT SAFETY LEVER R)	
62	3-354-955-01	LEVER (EJECT SAFETY LEVER L)	
63	3-354-962-01	SPRING (EJECT SAFETY SPRING R)	
64	3-354-961-01	SPRING (EJECT SAFETY SPRING L)	
65	*3-354-954-01	LEVER (LOCK LEVER R)	
66	*3-354-953-01	LEVER (LOCK LEVER L)	
67	3-354-957-01	JOINT (LOCK LEVER)	
68	3-354-960-01	SPRING (LOADING R), TORSION	
69	3-354-959-01	SPRING (LOADING L), TORSION	

Ref.No	Part No.	Description	Remarks
70	*3-682-419-21	HOLDER, P.C.B	
71	3-354-932-01	BUTTON (POWER)	
72	*4-933-135-01	RING (DIA. 58A), ORNAMENTAL	
73	7-685-134-19	SCREW (+ PTPWH)(2.6X8)	
74	3-359-926-01	KNOB (RT-90)	
75	3-359-926-11	KNOB (RT-90)	
76	9-911-844-XX	CUSHION	
77	4-925-125-01	HOLDER, FL TUBE	
901	*A-2006-254-A	MOUNTED PCB, AUDIO SYSTEM CONTROL	
906	*1-575-847-11	WIRE, FLAT TYPE (5 CORE)	
907	*1-575-851-11	WIRE, FLAT TYPE (7 CORE)	
908	*1-575-848-11	WIRE, FLAT TYPE (5 CORE)	
909	*1-575-853-11	WIRE, FLAT TYPE (15 CORE)	
910	1-534-517-00	WIRE, FLAT TYPE (11 CORE)	
911	*1-575-780-11	WIRE, FLAT TYPE (5 CORE)	
912	*A-2006-255-A	MOUNTED PCB, PANEL	
913	*1-575-850-11	WIRE, FLAT TYPE (9 CORE)	
914	*1-575-781-11	WIRE, FLAT TYPE (9 CORE)	
FL901	1-519-593-11	INDICATOR TUBE, FLUORESCENT	
J501	1-507-796-71	JACK (PHONES)	
S87	1-572-393-11	SWITCH, LEAF (DIRECTION)	

**6-3. FRONT PANEL SECTION  
(WR720)**

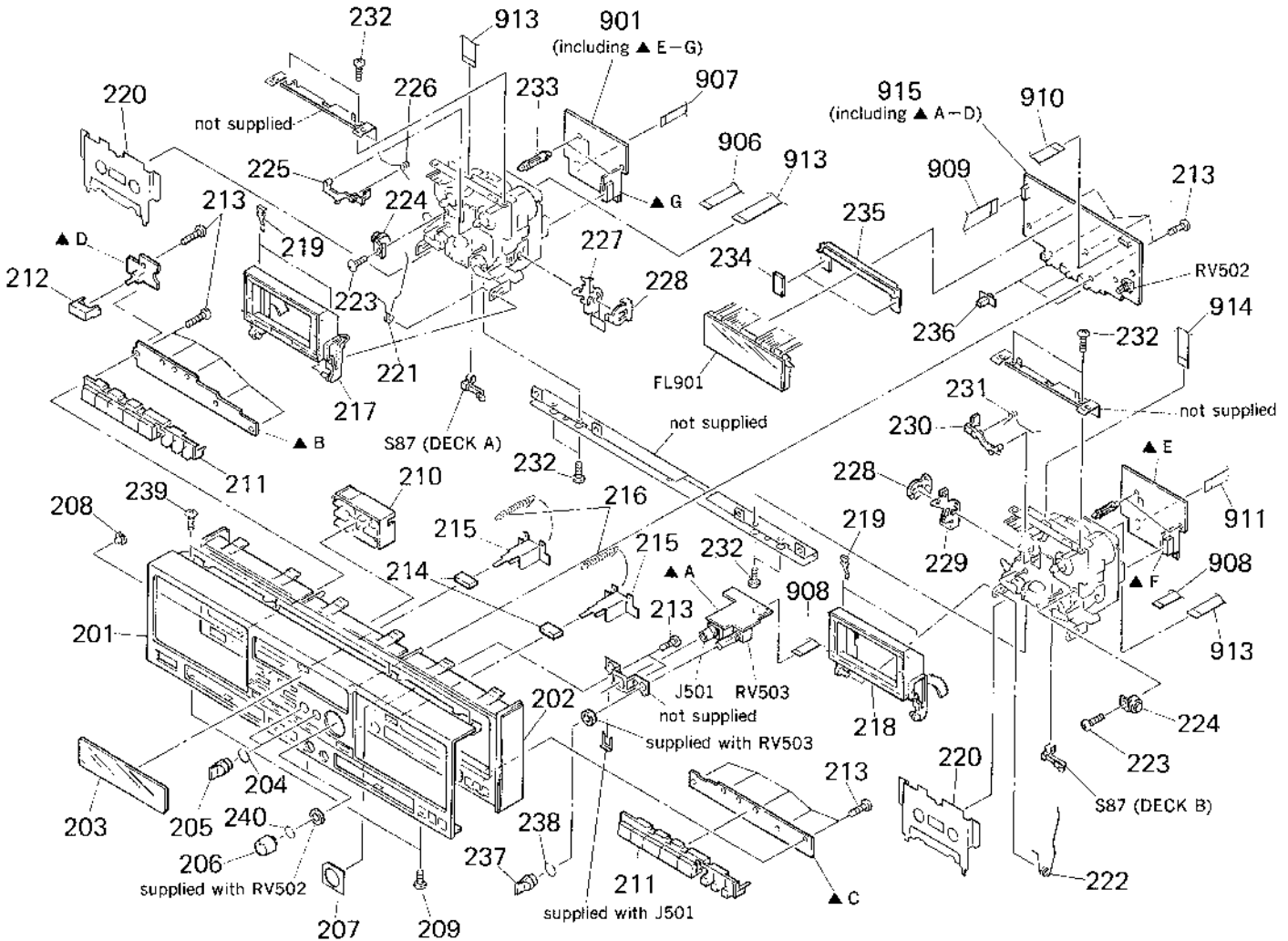

Ref.No	Part No.	Description	Remarks
201	3-354-939-51	PANEL, FRONT	
202	3-354-916-12	PANEL (BASE)	
203	3-354-933-12	WINDOW (METER)	
204	3-354-981-01	SPRING (SUS), RING	
205	3-354-931-11	KNOB (DIA. 10)	
206	3-359-932-01	KNOB (REC LEVEL)	
207	3-354-923-01	PLATE (VOL), ORNAMENTAL	
208	3-354-924-01	PLATE, INDICATION	
209	7-685-534-19	SCREW +BTP 2.6X8 TYPE2 N-S	
210	3-354-938-01	BUTTON (B)	
211	3-354-937-01	BUTTON (A)	
212	3-354-932-01	BUTTON (POWER)	
213	4-928-635-01	SCREW, +BV (2.6X8) TAPPING	
214	3-359-907-01	BUTTON (EJECT)	
215	*3-359-935-01	LEVER (EJECT)	
216	3-362-234-01	SPRING, TENSION	
217	X-3340-195-1	HOLDER (R) ASSY, CASSETTE	219
218	X-3340-194-1	HOLDER (L) ASSY, CASSETTE	219
219	3-308-823-11	SPRING	
220	X-3346-313-1	RETAINER ASSY, CASSETTE	
221	3-354-960-01	SPRING (LOADING R), TORSION	
222	3-354-959-01	SPRING (LOADING L), TORSION	
223	7-621-773-95	SCREW +BVTT 2.6X6 (S)	
224	3-354-963-01	DAMPER	
225	3-354-956-01	LEVER (EJECT SAFETY LEVER R)	
226	3-354-962-01	SPRING (EJECT SAFETY SPRING R)	
227	*3-354-954-01	LEVER (LOCK LEVER R)	
228	3-354-957-01	JOINT (LOCK LEVER)	

Ref.No	Part No.	Description	Remarks
229	*3-354-953-01	LEVER (LOCK LEVER L)	
230	3-354-955-01	LEVER (EJECT SAFETY LEVER L)	
231	3-354-961-01	SPRING (EJECT SAFETY SPRING L)	
232	7-621-770-67	SCREW +BVTT 2.6X6 (S)	
233	*3-682-419-21	HOLDER, P.C.B	
234	9-911-844-XX	CUSHION	
235	4-925-125-01	HOLDER, FL TUBE	
236	4-922-518-01	KNOB (TIMER)	
237	3-354-931-01	KNOB (DIA. 10)	
238	3-356-935-01	SPRING	
239	7-682-547-04	SCREW +BVTT 3X6	
240	*3-362-235-01	SPRING (REC LEVEL), RING	
901	*A-2006-258-A	MOUNTED PCB, AUDIO SYSTEM CONTROL	
906	*1-575-847-11	WIRE, FLAT TYPE (5 CORE)	
907	*1-575-851-11	WIRE, FLAT TYPE (7 CORE)	
908	*1-575-848-11	WIRE, FLAT TYPE (5 CORE)	
909	*1-575-853-11	WIRE, FLAT TYPE (15 CORE)	
910	1-534-517-00	WIRE, FLAT TYPE (11 CORE)	
911	*1-575-780-11	WIRE, FLAT TYPE (7 CORE)	
913	*1-575-850-11	WIRE, FLAT TYPE (9 CORE)	
914	*1-575-781-11	WIRE, FLAT TYPE (9 CORE)	
915	*A-2006-259-A	MOUNTED, PCB, PANEL	
FL901	1-519-593-11	INDICATOR TUBE, FLUORESCENT	
J501	1-507-796-71	JACK (PHONES)	
RV502	1-241-133-11	RES. VAR. CARBON 50K/50K (REC LEVEL)	
RV503	1-238-085-11	RES. VAR. CARBON 20K/20K (PHONES LEVEL)	
S87	1-572-393-11	SWITCH, LEAF (DIRECTION)	

6-4. MECHANISM SECTION-1  
(DECK A, B: TCM-190RB12)

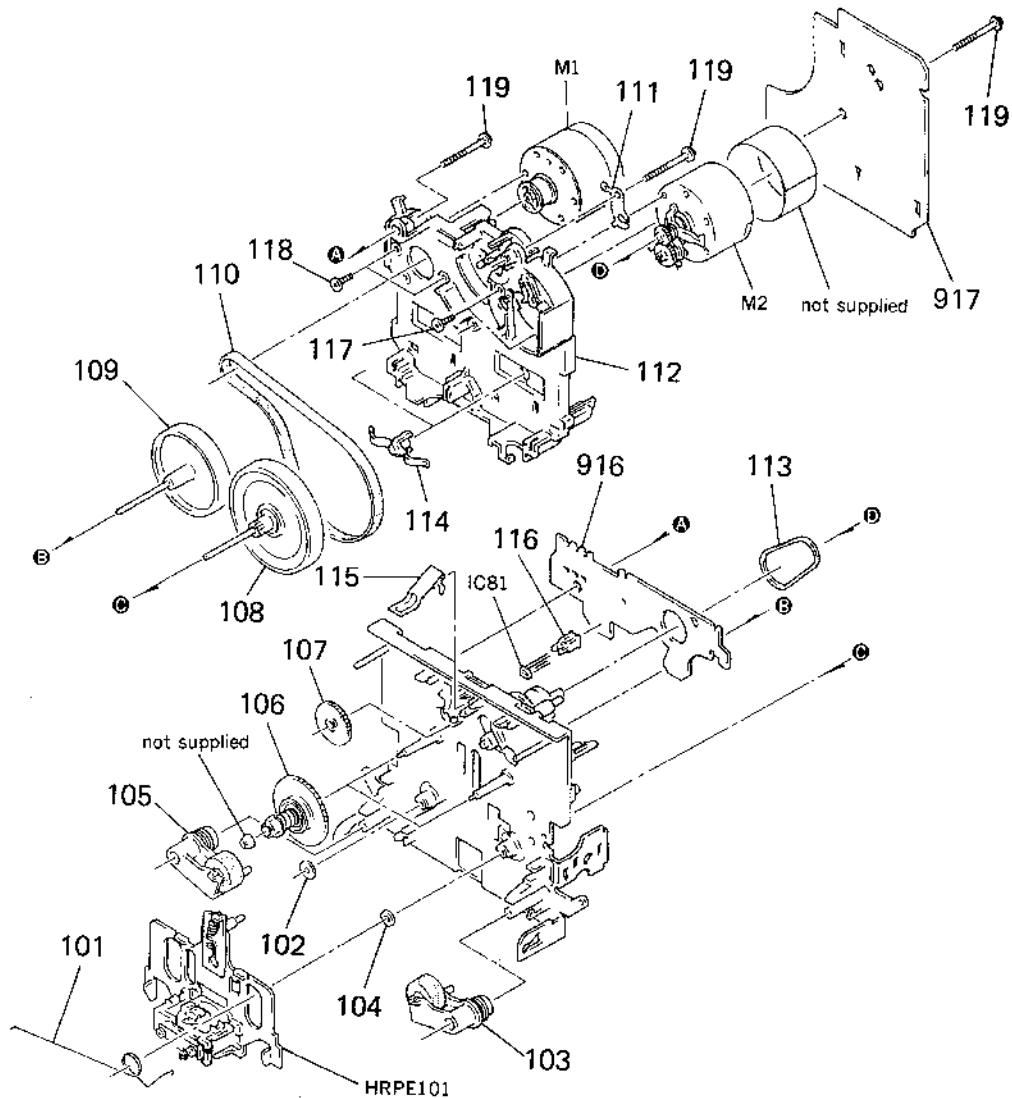

Ref.No	Part No.	Description	Remarks	Ref.No	Part No.	Description	Remarks
101	3-359-455-01	SPRING, TORSION		114	3-575-321-00	RETAINER, THRUST, CAPSTAN	
102	3-356-714-01	WASHER		115	3-359-430-01	SPRING(CASSETTE RETAINER),LEAF	
103	X-3359-408-1	LEVER (PINCH LEVER FWD) ASSY		116	3-343-419-01	HOLDER (S SENSER A)	
104	3-356-713-01	WASHER		117	7-627-556-08	SCREW +P 2.6X2.8	
105	X-3359-409-1	LEVER (PINCH LEVER REV) ASSY		118	7-621-775-00	SCREW +B 2.6X3	
106	X-3359-404-1	TABLE ASSY, REEL		119	3-359-414-01	SCREW (+PTPWH 2X23)	
107	3-359-424-01	GEAR (REV GEAR)		916	*1-634-841-11	PC BOARD, SW-A	
108	X-3359-406-1	FLYWHEEL (FWD) COMPLETE ASSY		917	*1-634-842-11	PC BOARD, MD (C)	
109	X-3359-410-1	FLYWHEEL (REV) ASSY		IC81	8-719-939-23	PHOTO REFLECTOR GP-2S09-C	
110	3-359-417-01	BELT (FLAT), CAPSTAN		HRPE101	A-2003-477-A	BASE ASSY, HEAD (REC/PB/ERASE)	
111	3-359-450-01	PLATE, GROUND		M1	X-3359-417-1	MOTOR ASSY (CAPASTAN)	
112	*3-359-436-01	BASE (THRUST RETAINER),FITTING		M2	A-2003-474-A	MOTOR (REEL MOTOR) ASSY	
113	3-359-466-01	BELT (FR), SQUARE					

6-5. MECHASISM SECTION-2  
(DECK A, B : TCM-190RB12)

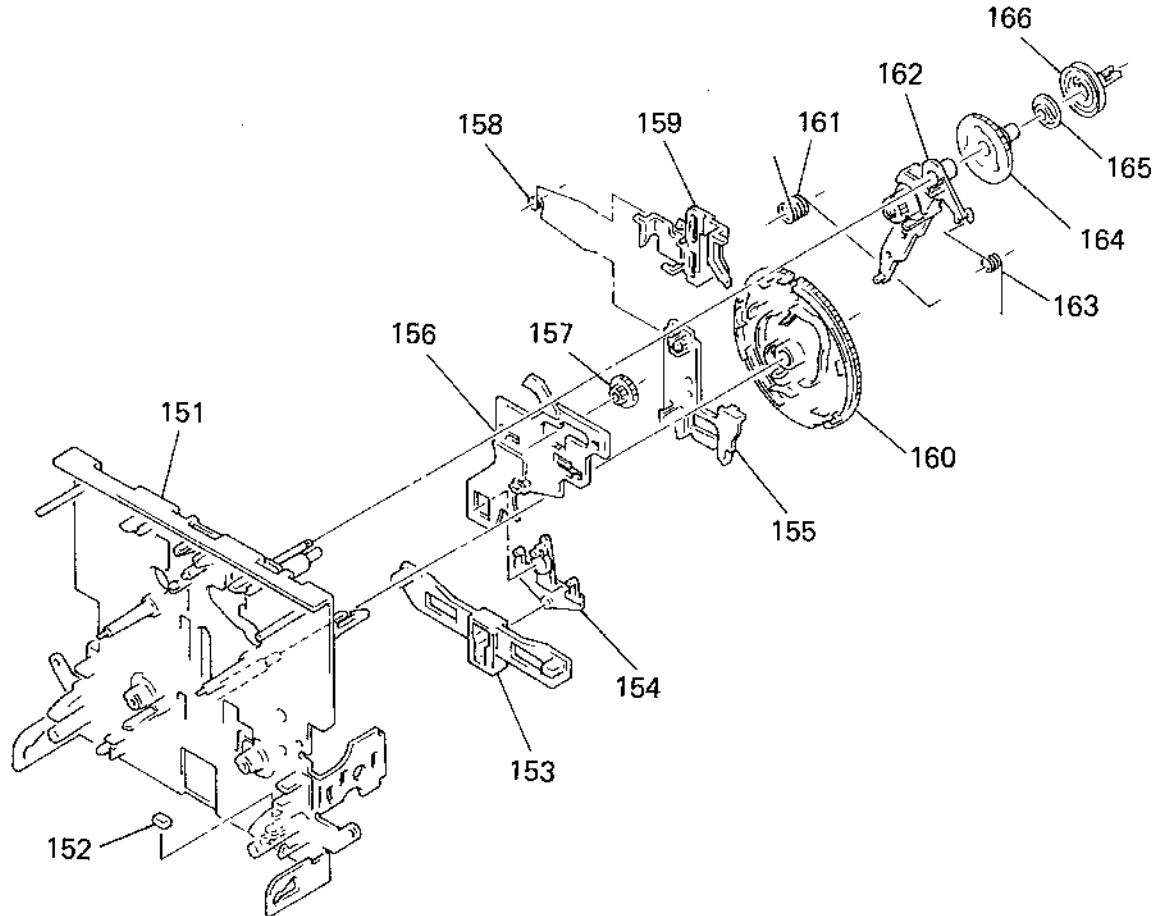

Ref.No	Part No.	Description	Remarks	Ref.No	Part No.	Description	Remarks
151	X-3359-415-1	CHASSIS ASSY, MECHANICAL		159	3-359-429-01	SLIDER (BRAKE PLATE)	
152	*3-359-469-01	SPACER		160	3-359-420-01	GEAR (CAM GEAR)	
153	*3-359-425-01	SLIDER (REVERSE SLIDER)		161	3-359-456-01	SPRING (TRIGGER SPRING), TORSION	
154	3-359-426-01	LEVER (REVERSE LEVER)		162	X-3359-405-1	LEVER (FR ARM) ASSY	
155	*3-359-427-01	SLIDER (REVERSE SLIDER)		163	3-359-453-01	SPRING (FR ARM), TORSION	
156	*3-359-415-01	SLIDER (TRIGGER SLIDER)		164	3-359-419-01	GEAR (FR GEAR)	
157	3-359-448-01	GEAR (TRIGGER)		165	3-359-421-01	CLUTCH (REEL DISK)	
158	3-359-454-01	SPRING, TORSION		166	3-359-418-01	PULLEY (FR PULLEY)	

## SECTION 7 ELECTRICAL PARTS LIST

**NOTE:**

- Due to standardization, replacements in the parts list may be different from the parts specified in the diagrams or the components used on the set.
- Items marked "★" are not stocked since they are seldom required for routine service. Some delay should be anticipated when ordering these items.
- If there are two or more same circuits in a set such as a stereophonic machine, only typical circuit parts may be indicated and capacitors and resistors in other same circuits may be omitted.

**CAPACITORS:**  
MF:  $\mu$ F, PF:  $\mu$ PF.

**RESISTORS**  
• All resistors are in ohms.  
• F: nonflammable

**COILS**  
• MMH: mH, UH:  $\mu$ H

**SEMICONDUCTORS**  
In each case, U:  $\mu$ , for example:  
UA....:  $\mu$ A...., UPA....:  $\mu$ PA....,  
UPC....:  $\mu$ PC, UPD....:  $\mu$ PD....

The components identified by mark or dotted line with mark are critical for safety. Replace only with part number specified.

Les composants identifiés par une marque sont critiques pour la sécurité. Ne les remplacer que par une pièce portant le numéro spécifié.

• WG.... West Germany model

Ref.No	Part No.	Description
901	*A-2006-254-A	(WR720A).... MOUNTED PCB, AUDIO SYSTEM CONTROL
901	*A-2006-258-A	(WR720).... MOUNTED PCB, AUDIO SYSTEM CONTROL
902	*1-533-213-31	HOLDER, FUSE
903	1-551-188-XX	(E)....CORD, POWER
904	1-551-506-XX	(US, Canadian)....CORD, POWER
905	1-555-795-00	(AEP, WG)....CORD, POWER, EULO PLUG
906	*1-575-847-11	WIRE, FLAT TYPE (5 CORE)
907	*1-575-851-11	WIRE, FLAT TYPE (7 CORE)
908	*1-575-848-11	WIRE, FLAT TYPE (5 CORE)
909	*1-575-853-11	WIRE, FLAT TYPE (15 CORE)
910	1-534-517-00	WIRE, FLAT TYPE (11 CORE)
911	*1-575-780-11	WIRE, FLAT TYPE (7 CORE)
912	*A-2006-255-A	(WR720A).... MOUNTED PCB, PANEL
913	*1-575-850-11	WIRE, FLAT TYPE (9 CORE)
914	*1-575-781-11	WIRE, FLAT TYPE (9 CORE)
915	*A-2006-259-A	(WR720).... MOUNTED, PCB, PANEL
916	*1-634-841-11	PC BOARD, SW-A
917	*1-634-842-11	PC BOARD, MD (C)

**CAPACITOR**

C11	1-110-342-11	MYLAR	390PF	5%	50V
C12	1-136-157-00	FILM	0.022MF	5%	50V
C13	1-124-282-00	ELECT	22MF	20%	25V
C21	1-110-342-11	MYLAR	390PF	5%	50V
C22	1-136-157-00	FILM	0.022MF	5%	50V
C23	1-124-282-00	ELECT	22MF	20%	25V
C31	1-124-443-00	ELECT	100MF	20%	10V
C32	1-124-443-00	ELECT	100MF	20%	10V
C33	1-124-119-00	ELECT	330MF	20%	16V
C51	1-136-230-00	FILM	0.0022MF	5%	100V
C52	1-136-230-00	FILM	0.0022MF	5%	100V
C53	1-130-856-00	FILM	0.0068MF	5%	100V
C54	1-136-601-11	FILM	0.01MF	5%	630V
C55	1-161-494-00	CERAMIC	0.022MF	5%	25V
C56	1-126-157-11	ELECT	10MF	20%	15V
C71	1-123-875-11	ELECT	10MF	20%	50V
C72	1-123-875-11	ELECT	10MF	20%	50V
C101	1-136-157-00	FILM	0.022MF	5%	50V
C102	1-162-294-31	CERAMIC	0.001MF	10%	50V
C103	1-161-375-00	(WR720).... CERAMIC	0.0022MF	20%	16V
C104	1-130-475-00	MYLAR	0.0022MF	5%	50V
C105	1-130-475-00	MYLAR	0.0022MF	5%	50V
C106	1-136-174-00	FILM	0.56MF	5%	50V
C107	1-136-171-00	FILM	0.33MF	5%	50V
C108	1-123-875-11	ELECT	10MF	20%	50V
C109	1-124-446-11	ELECT	47MF	20%	10V
C110	1-123-875-11	ELECT	10MF	20%	50V
C111	1-124-791-11	ELECT	1MF	20%	50V
C121	1-123-875-11	ELECT	10MF	20%	50V
C122	1-123-875-11	ELECT	10MF	20%	50V
C124	1-124-902-00	ELECT	0.47MF	20%	50V
C131	1-123-382-00	ELECT	3.3MF	20%	50V
C151	1-123-875-11	ELECT	10MF	20%	50V

Ref.No	Part No.	Description			
C152	1-123-875-11	ELECT	10MF	20%	50V
C154	1-124-902-00	ELECT	0.47MF	20%	50V
C181	1-126-096-11	(WR720).... ELECT	10MF	20%	25V
C201	1-136-157-00	FILM	0.022MF	5%	50V
C202	1-162-294-31	CERAMIC	0.001MF	10%	50V
C203	1-161-375-00	(WR720).... CERAMIC	0.0022MF	20%	16V
C204	1-130-475-00	MYLAR	0.0022MF	5%	50V
C205	1-130-475-00	MYLAR	0.0022MF	5%	50V
C206	1-136-174-00	FILM	0.56MF	5%	50V
C207	1-136-171-00	FILM	0.33MF	5%	50V
C208	1-123-875-11	ELECT	10MF	20%	50V
C209	1-124-446-11	ELECT	47MF	20%	10V
C210	1-123-875-11	ELECT	10MF	20%	50V
C211	1-124-791-11	ELECT	1MF	20%	50V
C221	1-123-875-11	ELECT	10MF	20%	50V
C222	1-123-875-11	ELECT	10MF	20%	50V
C224	1-124-902-00	ELECT	0.47MF	20%	50V
C231	1-123-382-00	ELECT	3.3MF	20%	50V
C251	1-123-875-11	ELECT	10MF	20%	50V
C252	1-123-875-11	ELECT	10MF	20%	50V
C254	1-124-902-00	ELECT	0.47MF	20%	50V
C281	1-126-096-11	(WR720).... ELECT	10MF	20%	25V
C391	1-136-273-91	FILM	75PF	5%	630V
C392	1-162-288-31	CERAMIC	330PF	10%	50V
C393	1-130-472-00	MYLAR	0.0012MF	5%	50V
C394	1-136-433-11	FILM	100PF	5%	630V
C395	1-136-437-11	FILM	220PF	5%	630V
C396	1-136-165-00	FILM	0.1MF	5%	50V
C397	1-136-157-00	FILM	0.022MF	5%	50V
C398	1-136-153-00	FILM	0.01MF	5%	50V
C491	1-136-273-91	FILM	75PF	5%	630V
C492	1-162-288-31	CERAMIC	330PF	10%	50V
C493	1-130-472-00	MYLAR	0.0012MF	5%	50V
C494	1-136-433-11	FILM	100PF	5%	630V
C495	1-136-437-11	FILM	220PF	5%	630V
C496	1-136-165-00	FILM	0.1MF	5%	50V
C497	1-136-157-00	FILM	0.022MF	5%	50V
C498	1-136-153-00	FILM	0.01MF	5%	50V
C506	1-124-791-11	ELECT	1MF	20%	50V
C542	1-124-925-11	ELECT	2.2MF	20%	50V
C591	1-124-473-11	ELECT	1000MF	20%	10V
C592	1-124-589-11	(WR720).... ELECT	47MF	20%	16V
C593	1-124-589-11	(WR720).... ELECT	47MF	20%	16V
C599	1-124-925-11	ELECT	2.2MF	20%	50V
C601	1-124-925-11	ELECT	2.2MF	20%	50V
C602	1-162-286-31	CERAMIC	220PF	10%	50V
C603	1-162-286-31	CERAMIC	220PF	10%	50V
C604	1-124-925-11	ELECT	2.2MF	20%	50V
C605	1-136-157-00	FILM	0.022MF	5%	50V
C608	1-124-925-11	ELECT	2.2MF	20%	50V
C691	1-107-046-00	MICA	4.7PF	0.5PF	500V
C692	1-124-446-11	ELECT	47MF	20%	10V
C693	1-126-101-11	ELECT	100MF	20%	16V
C694	1-124-902-00	ELECT	0.47MF	20%	50V
C701	1-124-443-00	ELECT	100MF	20%	6.3V

Ref.No	Part No.	Description			
C702	1-124-122-11	ELECT	100MF	20%	35V
C703	1-124-925-11	ELECT	2.2MF	20%	50V
C704	1-124-911-11	ELECT	220MF	20%	50V
C705	1-124-927-11	ELECT	4.7MF	20%	50V
C707	1-124-925-11	ELECT	2.2MF	20%	50V
C708	1-124-564-11	ELECT	4700MF	20%	25V
C709	1-124-446-11	ELECT	47MF	20%	10V
C710	1-124-473-11	ELECT	1000MF	20%	10V
C711	1-124-473-11	ELECT	1000MF	20%	10V
C712	1-126-946-11	ELECT	6800MF	20%	25V
C713	1-161-494-00	CERAMIC	0.022MF		25V
C801	1-124-443-00	ELECT	100MF	20%	6.3V
C802	1-164-159-11	CERAMIC	0.1MF		50V
C803	1-162-306-11	CERAMIC	0.01MF	20%	16V
C804	1-124-443-00	ELECT	100MF	20%	6.3V
C805	1-124-925-11	ELECT	2.2MF	20%	50V
C806	1-136-165-00	FILM	0.1MF	5%	50V
C807	1-136-165-00	FILM	0.1MF	5%	50V
C851	1-124-902-00	ELECT	0.47MF	20%	50V
C861	1-162-294-31	CERAMIC	0.001MF	10%	50V
C901	1-164-159-11	CERAMIC	0.1MF		50V
C902	1-124-443-00	(WR720A)...ELECT	100MF	20%	6.3V
C902	1-126-154-11	(WR720)...ELECT	47MF	20%	6.3V
C904	1-162-306-11	(WR720)...CERAMIC	0.01MF	20%	16V
C904	1-164-159-11	(WR720A)...CERAMIC	0.1MF		50V
C905	1-124-927-11	(WR720)...ELECT	4.7MF	20%	50V
C0391	1-136-273-91	FILM	75PF	5%	630V
C0392	1-162-288-31	CERAMIC	330PF	10%	50V
C0393	1-130-472-00	MYLAR	0.0012MF	5%	50V
C0394	1-136-433-11	FILM	100PF	5%	630V
C0395	1-136-437-11	FILM	220PF	5%	630V
C0396	1-136-165-00	FILM	0.1MF	5%	50V
C0397	1-136-157-00	FILM	0.022MF	5%	50V
C0398	1-136-153-00	FILM	0.01MF	5%	50V
C0491	1-136-273-91	FILM	75PF	5%	630V
C0492	1-162-288-31	CERAMIC	330PF	10%	50V
C0493	1-130-472-00	MYLAR	0.0012MF	5%	50V
C0494	1-136-433-11	FILM	100PF	5%	630V
C0495	1-136-437-11	FILM	220PF	5%	630V
C0496	1-136-165-00	FILM	0.1MF	5%	50V
C0497	1-136-157-00	FILM	0.022MF	5%	50V
C0498	1-136-153-00	FILM	0.01MF	5%	50V
C0691	1-107-046-00	MICA	4.7PF	0.5PF	500V
C0692	1-124-446-11	ELECT	47MF	20%	10V
C0693	1-126-101-11	ELECT	100MF	20%	16V
C0694	1-124-902-00	ELECT	0.47MF	20%	50V
CN501	*1-568-824-11	SOCKET, CONNECTOR 5P			
CN502	*1-568-824-11	SOCKET, CONNECTOR 5P			
CN503	*1-568-826-11	SOCKET, CONNECTOR 7P			
CN504	*1-568-826-11	SOCKET, CONNECTOR 7P			
CN505	*1-564-337-00	(WR720A)...PIN, CONNECTOR 3P			
CN505	*1-564-824-11	(WR720)...SOCKET, CONNECTOR 5P			
CN506	*1-568-848-11	(WR720)...SOCKET, CONNECTOR 5P			
CN601	*1-564-509-11	PLUG, CONNECTOR 6P			
CN691	*1-568-826-11	SOCKET, CONNECTOR 7P			
CN701	*1-564-338-00	(WR720)...PIN, CONNECTOR 4P			
CN701	*1-564-339-00	(WR720A)...PIN, CONNECTOR 5P			
CN703	*1-564-510-11	PLUG, CONNECTOR 7P			
CN801	*1-568-830-11	SOCKET, CONNECTOR 11P			
CN802	*1-568-828-11	SOCKET, CONNECTOR 9P			
CN803	*1-568-828-11	SOCKET, CONNECTOR 9P			
CN804	*1-568-828-11	SOCKET, CONNECTOR 9P			
CN805	*1-568-828-11	SOCKET, CONNECTOR 9P			
CN806	*1-568-834-11	SOCKET, CONNECTOR 15P			

Ref.No	Part No.	Description
CN901	*1-568-834-11	(WR720)...SOCKET, CONNECTOR 15P
CN901	*1-568-858-11	(WR720A)...SOCKET, CONNECTOR 15P
CN902	*1-568-830-11	(WR720)...SOCKET, CONNECTOR 11P
CN902	*1-568-854-11	(WR720A)...SOCKET, CONNECTOR 11P
CN904	*1-564-498-11	(WR720)...PIN, CONNECTOR 5P
CN905	*1-564-498-11	(WR720)...PIN, CONNECTOR 5P
CN906	*1-564-498-11	(WR720)...PIN, CONNECTOR 5P
CN0691	*1-568-826-11	SOCKET, CONNECTOR 7P
CNP31	*1-568-824-11	SOCKET, CONNECTOR 5P
CNP32	*1-564-709-11	PIN, CONNECTOR (SMALL TYPE) 7P
CNP34	*1-565-344-11	PIN, CONNECTOR (PC BOARD) 8P
CNP35	*1-564-706-11	PIN, CONNECTOR (SMALL TYPE) 4P
CNP71	*1-564-705-11	PIN, CONNECTOR (SMALL TYPE) 3P
CNP72	*1-564-706-11	PIN, CONNECTOR (SMALL TYPE) 4P
CNP73	*1-568-828-11	SOCKET, CONNECTOR 9P
CNP75	*1-564-704-11	PIN, CONNECTOR (SMALL TYPE) 2P
CNP81	*1-568-852-11	SOCKET, CONNECTOR 9P
CNP691	*1-565-347-11	SOCKET, CONNECTOR (PC BOARD)8P
CNP691	*1-565-347-11	SOCKET, CONNECTOR (PC BOARD)8P
CP901	1-233-125-11	(WR720)...COMPOSITION CIRCUIT BLOCK (10KX4)
CP901	1-233-219-11	(WR720A)...COMPOSITION CIRCUIT BLOCK
CP902	1-233-125-11	(WR720)...COMPOSITION CIRCUIT BLOCK (10KX4)
CP902	1-233-136-11	(WR720A)...COMPOSITION CIRCUIT BLOCK (10KX8)
CP903	1-233-219-11	(WR720)...COMPOSITION CIRCUIT BLOCK
D31	8-719-107-94	DIODE 1SS202-1
D131	8-719-107-94	DIODE 1SS202-1
D231	8-719-107-94	DIODE 1SS202-1
D501	8-719-107-94	(WR720)...DIODE 1SS202-1
D502	8-719-107-94	DIODE 1SS202-1
D503	8-719-933-54	DIODE HZS9A2L
D571	8-719-107-94	DIODE 1SS202-1
D572	8-719-001-36	DIODE UZL-11L2
D601	8-719-107-94	DIODE 1SS202-1
D602	8-719-107-94	DIODE 1SS202-1
D701	8-719-000-78	DIODE UZL-7L2
D702	8-719-107-94	DIODE 1SS202-1
D703	8-719-200-77	DIODE 10E2N
D704	8-719-200-77	DIODE 10E2N
D705	8-719-200-77	DIODE 10E2N
D706	8-719-107-94	DIODE 1SS202-1
D707	8-719-200-77	DIODE 10E2N
D708	8-719-200-77	DIODE 10E2N
D709	8-719-933-33	DIODE HZS6A1L
D710	8-719-200-77	DIODE 10E2N
D711	8-719-200-77	DIODE 10E2N
D712	8-719-933-33	DIODE HZS6A1L
D713	8-719-000-93	DIODE UZL-7H1
D801	8-719-107-94	DIODE 1SS202-1
D811	8-719-107-94	DIODE 1SS202-1
D812	8-719-107-94	DIODE 1SS202-1
D902	8-719-301-39	DIODE SEL2210S
F701	▲1-532-259-00	(AEP, WG, E)...FUSE, TIME-LAG (T1.6A/250V)
F701	▲1-532-742-11	(US, Canadian)...FUSE, GLASS TUBE (1.6A/125V)
F702	▲1-532-259-00	(AEP, WG, E)...FUSE, TIME-LAG (T1.6A/250V)
F702	▲1-532-742-11	(US, Canadian)...FUSE, GLASS TUBE (1.6A/125V)
FL901	1-519-593-11	INDICATOR TUBE, FLUORESCENT
HRPE101	A-2003-477-A	BASE ASSY. HEAD (REC/PB/ERASE)
IC31	8-759-111-44	IC UPC4570C-1
IC81	8-719-939-23	PHOTO REFLECTOR GP-2S09-C
IC501	8-752-036-34	IC CXA1330S
IC503	8-759-945-58	IC RC4558P
IC504	8-759-945-58	IC RC4558P

**Note:**  
The components identified by mark ▲ or dotted line with mark ▲ are critical for safety. Replace only with part number specified.

**Note:**  
Les composants identifiés par une marque ▲ sont critiques pour la sécurité. Ne les remplacer que par une pièce portant le numéro spécifié.

Ref.No	Part No.	Description
IC506	8-759-040-53	IC MC14053BCP
IC509	8-752-038-02	IC CXA1198AP
IC510	8-759-208-06	IC MC14051BCP
IC551	8-752-038-02	IC CXA1198AP
IC601	8-759-634-50	(WR720)....IC M5218AL
IC601	8-759-634-51	(WR720A)....IC M5218AP
IC691	8-759-106-56	IC UPC1297CA
IC701	8-759-945-58	IC RC4558P
IC802	8-759-634-83	IC M50925-446SP
IC803	8-759-634-84	IC M50255P
IC804	8-759-240-50	IC MC14050BCP
IC805	8-759-207-05	IC TA7272P
IC806	8-759-208-08	IC MC14052BCP
IC807	8-759-208-08	IC MC14052BCP
IC901	8-759-634-68	IC M50941-358SP
IC902	8-741-100-48	IC SBX1610-59
IC0691	8-759-106-56	IC UPC1297CA
J301	1-565-258-11	JACK, PIN 4P (LINE IN/OUT)
J501	1-507-796-71	JACK (PHONES)
L391	1-410-780-11	INDUCTOR 27MMH
L491	1-410-780-11	INDUCTOR 27MMH
L0391	1-410-780-11	INDUCTOR 27MMH
L0491	1-410-780-11	INDUCTOR 27MMH
LPF101	1-235-980-11	(WR720)....FILTER, LOW PASS
LPF101	1-236-087-11	(WR720A)....FILTER, LOW PASS
LPF201	1-235-980-11	(WR720)....FILTER, LOW PASS
LPF201	1-236-087-11	(WR720A)....FILTER, LOW PASS
M1	X-3359-417-1	MOTOR ASSY (CAPASTAN)
M2	A-2003-474-A	MOTOR (REEL MOTOR) ASSY
Q51	8-729-194-57	TRANSISTOR 2SC945-P
Q52	8-729-194-57	TRANSISTOR 2SC945-P
Q53	8-729-801-84	TRANSISTOR 2SB1013-4
Q71	8-729-820-16	TRANSISTOR 2SA1317-S
Q101	8-729-900-74	TRANSISTOR DTC143TS
Q102	8-729-900-74	(WR720)....TRANSISTOR DTC143TS
Q121	8-729-821-31	TRANSISTOR 2SD1012-FG
Q171	8-729-821-31	TRANSISTOR 2SD1012-FG
Q201	8-729-900-74	TRANSISTOR DTC143TS
Q202	8-729-900-74	(WR720)....TRANSISTOR DTC143TS
Q221	8-729-821-31	TRANSISTOR 2SD1012-FG
Q271	8-729-821-31	TRANSISTOR 2SD1012-FG
Q501	8-729-900-65	TRANSISTOR DTA144ES
Q502	8-729-900-65	TRANSISTOR DTA144ES
Q503	8-729-900-65	(WR720)....TRANSISTOR DTA144ES
Q504	8-729-900-65	TRANSISTOR DTA144ES
Q505	8-729-900-89	TRANSISTOR DTC144ES
Q521	8-729-900-61	TRANSISTOR DTA114ES
Q551	8-729-900-61	TRANSISTOR DTA114ES
Q552	8-729-821-31	TRANSISTOR 2SD1012-FG
Q553	8-729-821-31	TRANSISTOR 2SD1012-FG
Q571	8-729-900-65	TRANSISTOR DTA144ES
Q572	8-729-821-04	TRANSISTOR 2SA1317-STU
Q601	8-729-900-89	TRANSISTOR DTC144ES
Q701	8-729-920-98	TRANSISTOR 2SD1761-EF
Q702	8-729-620-05	TRANSISTOR 2SC2603-EF
Q703	8-729-821-04	TRANSISTOR 2SA1317-STU
Q704	8-729-920-97	TRANSISTOR 2SB1187-EF
Q705	8-729-920-97	TRANSISTOR 2SB1187-EF
Q706	8-729-900-85	TRANSISTOR DTC144WS
Q707	8-729-920-98	TRANSISTOR 2SD1761-EF
Q708	8-729-900-89	TRANSISTOR DTC144ES
Q801	8-729-801-84	TRANSISTOR 2SB1013-4
Q802	8-729-801-84	TRANSISTOR 2SB1013-4
Q803	8-729-900-61	TRANSISTOR DTA114ES

Ref.No	Part No.	Description
Q804	8-729-900-80	TRANSISTOR 2SC3402-TP
Q805	8-729-900-61	TRANSISTOR DTA114ES
Q806	8-729-900-61	TRANSISTOR DTA114ES
Q807	8-729-821-04	TRANSISTOR 2SA1317-STU
Q851	8-729-900-61	TRANSISTOR DTA114ES
Q852	8-729-900-89	TRANSISTOR DTC144ES
Q853	8-729-900-61	TRANSISTOR DTA114ES
Q854	8-729-900-89	TRANSISTOR DTC144ES
Q891	8-729-900-61	TRANSISTOR DTA114ES
Q901	8-729-900-65	TRANSISTOR DTA144ES
Q902	8-729-620-05	TRANSISTOR 2SC2603-EF
Q903	8-729-620-05	TRANSISTOR 2SC2603-EF
Q904	8-729-900-74	TRANSISTOR DTC143TS
Q905	8-729-620-05	(WR720)....TRANSISTOR 2SC2603-EF
Q906	8-729-620-05	(WR720)....TRANSISTOR 2SC2603-EF
Q907	8-729-620-05	(WR720)....TRANSISTOR 2SC2603-EF
Q908	8-729-620-05	(WR720)....TRANSISTOR 2SC2603-EF

RESISTOR

Ref.No	Part No.	Description	Value	Power	Temp	Notes
R11	1-247-881-00	CARBON	120K	5%	1/4W	
R12	1-249-405-11	CARBON	100	5%	1/4W	
R13	1-247-882-11	CARBON	130K	5%	1/4W	
R14	1-249-426-11	CARBON	5.6K	5%	1/4W	
R21	1-247-881-00	CARBON	120K	5%	1/4W	
R22	1-249-405-11	CARBON	100	5%	1/4W	
R23	1-247-882-11	CARBON	130K	5%	1/4W	
R24	1-249-426-11	CARBON	5.6K	5%	1/4W	
R31	1-249-409-11	CARBON	220	5%	1/4W	
R32	1-249-409-11	CARBON	220	5%	1/4W	
R51	1-249-441-11	CARBON	100K	5%	1/4W	
R52	1-249-441-11	CARBON	100K	5%	1/4W	
R53	1-249-429-11	CARBON	10K	5%	1/4W	
R54	1-212-851-00	FUSIBLE	5.6	5%	1/4W	F
R55	1-249-429-11	CARBON	10K	5%	1/4W	
R71	1-247-864-11	CARBON	24K	5%	1/4W	
R72	1-249-433-11	CARBON	22K	5%	1/4W	
R73	1-249-437-11	CARBON	47K	5%	1/4W	
R74	1-249-437-11	CARBON	47K	5%	1/4W	
R81	1-249-414-11	CARBON	560	5%	1/4W	
R82	1-247-818-11	CARBON	300	5%	1/4W	
R83	1-247-834-11	CARBON	1.3K	5%	1/4W	
R84	1-249-417-11	CARBON	1K	5%	1/4W	
R85	1-249-408-11	CARBON	180	5%	1/4W	
R101	1-249-423-11	CARBON	3.3K	5%	1/4W	
R102	1-247-887-00	CARBON	220K	5%	1/4W	
R103	1-249-441-11	(WR720).... CARBON	100K	5%	1/4W	
R104	1-249-423-11	CARBON	3.3K	5%	1/4W	
R105	1-249-428-11	CARBON	8.2K	5%	1/4W	
R106	1-247-864-11	CARBON	24K	5%	1/4W	
R107	1-249-414-11	CARBON	560	5%	1/4W	
R119	1-249-421-11	CARBON	2.2K	5%	1/4W	
R121	1-249-425-11	CARBON	4.7K	5%	1/4W	
R124	1-249-426-11	CARBON	5.6K	5%	1/4W	
R125	1-249-421-11	CARBON	2.2K	5%	1/4W	
R126	1-249-429-11	CARBON	10K	5%	1/4W	
R131	1-249-408-11	CARBON	180	5%	1/4W	
R132	1-249-433-11	(WR720A).... CARBON	22K	5%	1/4W	
R132	1-249-434-11	(WR720).... CARBON	27K	5%	1/4W	
R133	1-249-421-11	CARBON	2.2K	5%	1/4W	
R134	1-249-435-11	CARBON	33K	5%	1/4W	
R151	1-249-425-11	CARBON	4.7K	5%	1/4W	
R153	1-249-421-11	CARBON	2.2K	5%	1/4W	
R155	1-249-426-11	CARBON	5.6K	5%	1/4W	



# TC-WR720/WR720A

Ref.No	Part No.	Description			
R156	1-249-429-11	CARBON	10K	5%	1/4W
R171	1-249-433-11	CARBON	22K	5%	1/4W
R172	1-249-417-11	CARBON	1K	5%	1/4W
R173	1-247-858-11	CARBON	13K	5%	1/4W
R174	1-249-421-11	CARBON	2.2K	5%	1/4W
R181	1-249-429-11	(WR720A).... CARBON	10K	5%	1/4W
R181	1-249-433-11	(WR720).... CARBON	22K	5%	1/4W
R182	1-249-421-11	(WR720).... CARBON	2.2K	5%	1/4W
R183	1-249-433-11	(WR720).... CARBON	22K	5%	1/4W
R184	1-249-405-11	(WR720A).... CARBON	100	5%	1/4W
R184	1-249-409-11	(WR720).... CARBON	220	5%	1/4W
R191	1-249-420-11	CARBON	1.8K	5%	1/4W
R201	1-249-423-11	CARBON	3.3K	5%	1/4W
R202	1-247-887-00	CARBON	220K	5%	1/4W
R203	1-249-441-11	(WR720).... CARBON	100K	5%	1/4W
R204	1-249-423-11	CARBON	3.3K	5%	1/4W
R205	1-249-428-11	CARBON	8.2K	5%	1/4W
R206	1-247-864-11	CARBON	24K	5%	1/4W
R207	1-249-414-11	CARBON	560	5%	1/4W
R219	1-249-421-11	CARBON	2.2K	5%	1/4W
R221	1-249-425-11	CARBON	4.7K	5%	1/4W
R224	1-249-426-11	CARBON	5.6K	5%	1/4W
R225	1-249-421-11	CARBON	2.2K	5%	1/4W
R226	1-249-429-11	CARBON	10K	5%	1/4W
R231	1-249-408-11	CARBON	180	5%	1/4W
R232	1-249-433-11	(WR720A).... CARBON	22K	5%	1/4W
R232	1-249-434-11	(WR720).... CARBON	27K	5%	1/4W
R233	1-249-421-11	CARBON	2.2K	5%	1/4W
R234	1-249-435-11	CARBON	33K	5%	1/4W
R251	1-249-425-11	CARBON	4.7K	5%	1/4W
R253	1-249-421-11	CARBON	2.2K	5%	1/4W
R255	1-249-426-11	CARBON	5.6K	5%	1/4W
R256	1-249-429-11	CARBON	10K	5%	1/4W
R271	1-249-433-11	CARBON	22K	5%	1/4W
R272	1-249-417-11	CARBON	1K	5%	1/4W
R273	1-247-858-11	CARBON	13K	5%	1/4W
R274	1-249-421-11	CARBON	2.2K	5%	1/4W
R281	1-249-429-11	(WR720A).... CARBON	10K	5%	1/4W
R281	1-249-433-11	(WR720).... CARBON	22K	5%	1/4W
R282	1-249-421-11	(WR720).... CARBON	2.2K	5%	1/4W
R283	1-249-433-11	(WR720).... CARBON	22K	5%	1/4W
R284	1-249-405-11	(WR720A).... CARBON	100	5%	1/4W
R284	1-249-409-11	(WR720).... CARBON	220	5%	1/4W
R291	1-249-420-11	CARBON	1.8K	5%	1/4W
R391	1-249-430-11	CARBON	12K	5%	1/4W
R392	1-247-883-00	CARBON	150K	5%	1/4W
R393	1-249-393-11	CARBON	10	5%	1/4W
R394	1-249-431-11	CARBON	15K	5%	1/4W
R395	1-247-864-11	CARBON	24K	5%	1/4W
R491	1-249-430-11	CARBON	12K	5%	1/4W
R492	1-247-883-00	CARBON	150K	5%	1/4W
R493	1-249-393-11	CARBON	10	5%	1/4W
R494	1-249-431-11	CARBON	15K	5%	1/4W

Ref.No	Part No.	Description			
R495	1-247-864-11	CARBON	24K	5%	1/4W
R501	1-249-429-11	CARBON	10K	5%	1/4W
R502	1-249-434-11	CARBON	27K	5%	1/4W
R503	1-249-417-11	CARBON	1K	5%	1/4W
R504	1-249-429-11	CARBON	10K	5%	1/4W
R505	1-249-429-11	CARBON	10K	5%	1/4W
R506	1-249-429-11	CARBON	10K	5%	1/4W
R507	1-249-441-11	CARBON	100K	5%	1/4W
R521	1-249-440-11	CARBON	82K	5%	1/4W
R522	1-247-876-11	CARBON	75K	5%	1/4W
R523	1-247-882-11	CARBON	130K	5%	1/4W
R524	1-247-874-11	CARBON	62K	5%	1/4W
R525	1-249-434-11	CARBON	27K	5%	1/4W
R526	1-247-868-11	CARBON	36K	5%	1/4W
R527	1-247-887-00	CARBON	220K	5%	1/4W
R528	1-247-874-11	CARBON	62K	5%	1/4W
R529	1-247-883-00	CARBON	150K	5%	1/4W
R530	1-247-882-11	CARBON	130K	5%	1/4W
R531	1-247-868-11	CARBON	36K	5%	1/4W
R532	1-249-437-11	CARBON	47K	5%	1/4W
R533	1-247-890-11	CARBON	300K	5%	1/4W
R534	1-247-882-11	CARBON	130K	5%	1/4W
R535	1-247-874-11	CARBON	62K	5%	1/4W
R536	1-247-868-11	CARBON	36K	5%	1/4W
R537	1-247-870-11	CARBON	43K	5%	1/4W
R538	1-247-872-11	CARBON	51K	5%	1/4W
R539	1-247-864-11	CARBON	24K	5%	1/4W
R541	1-249-441-11	CARBON	100K	5%	1/4W
R542	1-249-417-11	CARBON	1K	5%	1/4W
R551	1-249-440-11	CARBON	82K	5%	1/4W
R552	1-247-876-11	CARBON	75K	5%	1/4W
R553	1-247-882-11	CARBON	130K	5%	1/4W
R554	1-247-874-11	(WR720A).... CARBON	62K	5%	1/4W
R554	1-247-876-11	(WR720).... CARBON	75K	5%	1/4W
R555	1-249-434-11	(WR720A).... CARBON	27K	5%	1/4W
R555	1-249-435-11	(WR720).... CARBON	33K	5%	1/4W
R556	1-247-868-11	(WR720A).... CARBON	36K	5%	1/4W
R556	1-249-436-11	(WR720).... CARBON	39K	5%	1/4W
R557	1-247-887-00	CARBON	220K	5%	1/4W
R558	1-247-874-11	CARBON	62K	5%	1/4W
R559	1-247-883-00	CARBON	150K	5%	1/4W
R560	1-247-882-11	CARBON	130K	5%	1/4W
R561	1-247-868-11	(WR720A).... CARBON	36K	5%	1/4W
R561	1-247-870-11	(WR720).... CARBON	43K	5%	1/4W
R562	1-249-437-11	(WR720A).... CARBON	47K	5%	1/4W
R562	1-249-438-11	(WR720).... CARBON	56K	5%	1/4W
R563	1-247-890-11	CARBON	300K	5%	1/4W
R564	1-247-882-11	CARBON	130K	5%	1/4W
R565	1-247-874-11	CARBON	62K	5%	1/4W
R566	1-247-868-11	(WR720A).... CARBON	36K	5%	1/4W
R566	1-249-436-11	(WR720).... CARBON	39K	5%	1/4W
R567	1-247-870-11	(WR720A).... CARBON	43K	5%	1/4W
R567	1-247-872-11	(WR720).... CARBON	51K	5%	1/4W

Ref.No	Part No.	Description							
R568	1-247-872-11	(WR720A).... CARBON	51K	5%	1/4W				
R568	1-247-874-11	(WR720).... CARBON	62K	5%	1/4W				
R569	1-247-880-11	CARBON	110K	5%	1/4W				
R570	1-247-858-11	CARBON	36K	5%	1/4W				
R571	1-247-874-11	CARBON	62K	5%	1/4W				
R572	1-247-858-11	(WR720A).... CARBON	36K	5%	1/4W				
R572	1-247-870-11	(WR720).... CARBON	43K	5%	1/4W				
R573	1-247-866-11	(WR720A).... CARBON	30K	5%	1/4W				
R573	1-247-868-11	(WR720).... CARBON	36K	5%	1/4W				
R574	1-249-432-11	(WR720A).... CARBON	18K	5%	1/4W				
R574	1-249-433-11	(WR720).... CARBON	22K	5%	1/4W				
R575	1-247-880-11	CARBON	110K	5%	1/4W				
R576	1-249-437-11	CARBON	47K	5%	1/4W				
R577	1-249-438-11	CARBON	56K	5%	1/4W				
R578	1-247-868-11	(WR720A).... CARBON	36K	5%	1/4W				
R578	1-247-870-11	(WR720).... CARBON	43K	5%	1/4W				
R579	1-247-870-11	(WR720A).... CARBON	43K	5%	1/4W				
R579	1-249-438-11	(WR720).... CARBON	56K	5%	1/4W				
R580	1-249-436-11	CARBON	39K	5%	1/4W				
R581	1-247-881-00	CARBON	120K	5%	1/4W				
R582	1-247-872-11	CARBON	51K	5%	1/4W				
R583	1-249-437-11	CARBON	47K	5%	1/4W				
R584	1-247-862-11	(WR720A).... CARBON	20K	5%	1/4W				
R584	1-249-434-11	(WR720).... CARBON	27K	5%	1/4W				
R585	1-247-874-11	(WR720).... CARBON	62K	5%	1/4W				
R585	1-249-438-11	(WR720A).... CARBON	56K	5%	1/4W				
R586	1-247-868-11	(WR720A).... CARBON	36K	5%	1/4W				
R586	1-249-436-11	(WR720).... CARBON	39K	5%	1/4W				
R587	1-247-864-11	CARBON	24K	5%	1/4W				
R591	1-249-409-11	CARBON	220	5%	1/4W				
R594	1-249-441-11	CARBON	100K	5%	1/4W				
R595	1-249-442-11	CARBON	510	5%	1/4W				
R598	1-249-441-11	CARBON	100K	5%	1/4W				
R599	1-249-417-11	CARBON	1K	5%	1/4W				
R602	1-247-887-00	CARBON	220K	5%	1/4W				
R603	1-249-425-11	CARBON	4.7K	5%	1/4W				
R604	1-249-441-11	CARBON	100K	5%	1/4W				
R605	1-249-428-11	CARBON	8.2K	5%	1/4W				
R606	1-249-437-11	CARBON	47K	5%	1/4W				
R607	1-249-417-11	CARBON	1K	5%	1/4W				
R608	1-249-441-11	CARBON	100K	5%	1/4W				
R609	1-249-423-11	CARBON	3.3K	5%	1/4W				
R701	1-249-421-11	CARBON	2.2K	5%	1/4W				
R702	1-249-421-11	CARBON	2.2K	5%	1/4W				
R703	1-247-856-00	CARBON	11K	5%	1/4W				
R704	1-249-428-11	CARBON	8.2K	5%	1/4W				
R705	1-249-425-11	CARBON	4.7K	5%	1/4W				
R706	1-249-429-11	CARBON	10K	5%	1/4W				
R707	1-249-409-11	CARBON	220	5%	1/4W				
R708	1-249-420-11	CARBON	1.8K	5%	1/4W				
R709	1-249-426-11	CARBON	5.6K	5%	1/4W				
R710	1-249-422-11	CARBON	2.7K	5%	1/4W				
R711	1-249-430-11	CARBON	12K	5%	1/4W				
R712	1-249-429-11	CARBON	10K	5%	1/4W				
R713	1-249-409-11	CARBON	220	5%	1/4W				
R714	1-249-429-11	CARBON	10K	5%	1/4W				
R715	1-249-429-11	CARBON	10K	5%	1/4W				
R721	1-249-429-11	CARBON	10K	5%	1/4W				
R801	1-249-434-11	CARBON	27K	5%	1/4W				
R804	1-249-434-11	CARBON	27K	5%	1/4W				
R805	1-247-895-00	CARBON	470K	5%	1/4W				
R806	1-247-895-00	CARBON	470K	5%	1/4W				
R807	1-247-895-00	CARBON	470K	5%	1/4W				
R808	1-247-895-00	CARBON	470K	5%	1/4W				
R809	1-249-425-11	CARBON	4.7K	5%	1/4W				
R810	1-247-862-11	CARBON	20K	5%	1/4W				
R811	1-249-425-11	CARBON	4.7K	5%	1/4W				
R812	1-247-862-11	CARBON	20K	5%	1/4W				
R813	1-249-437-11	CARBON	47K	5%	1/4W				
R814	1-247-866-11	CARBON	30K	5%	1/4W				
R815	1-249-435-11	CARBON	33K	5%	1/4W				
R816	1-247-872-11	CARBON	51K	5%	1/4W				
R818	1-247-872-11	CARBON	51K	5%	1/4W				
R819	1-249-405-11	CARBON	100	5%	1/4W				
R820	1-249-437-11	CARBON	47K	5%	1/4W				
R821	1-247-866-11	CARBON	30K	5%	1/4W				
R822	1-249-435-11	CARBON	33K	5%	1/4W				
R823	1-247-872-11	CARBON	51K	5%	1/4W				
R825	1-249-405-11	CARBON	100	5%	1/4W				
R826	1-247-872-11	CARBON	51K	5%	1/4W				
R827	1-249-441-11	CARBON	100K	5%	1/4W				
R828	1-249-429-11	CARBON	10K	5%	1/4W				
R829	1-249-429-11	CARBON	10K	5%	1/4W				
R830	1-249-429-11	CARBON	10K	5%	1/4W				
R831	1-249-429-11	CARBON	10K	5%	1/4W				
R832	1-249-417-11	CARBON	1K	5%	1/4W				
R833	1-249-435-11	CARBON	33K	5%	1/4W				
R858	1-249-432-11	CARBON	18K	5%	1/4W				
R859	1-249-436-11	CARBON	39K	5%	1/4W				
R860	1-247-854-11	CARBON	9.1K	5%	1/4W				
R862	1-247-858-11	(WR720).... CARBON	13K	5%	1/4W				
R862	1-249-432-11	(WR720A).... CARBON	18K	5%	1/4W				
R863	1-249-436-11	(WR720A).... CARBON	39K	5%	1/4W				
R864	1-247-854-11	(WR720A).... CARBON	9.1K	5%	1/4W				
R864	1-249-424-11	(WR720).... CARBON	3.9K	5%	1/4W				
R865	1-247-810-11	(WR720).... CARBON	130	5%	1/4W				
R868	1-249-429-11	CARBON	10K	5%	1/4W				
R869	1-249-429-11	CARBON	10K	5%	1/4W				
R870	1-249-429-11	CARBON	10K	5%	1/4W				
R874	1-247-903-00	CARBON	1M	5%	1/4W				
R891	1-249-429-11	CARBON	10K	5%	1/4W				
R892	1-249-429-11	CARBON	10K	5%	1/4W				
R893	1-249-415-11	CARBON	680	5%	1/4W				
R894	1-249-415-11	CARBON	680	5%	1/4W				
R901	1-249-429-11	CARBON	10K	5%	1/4W				
R902	1-249-429-11	CARBON	10K	5%	1/4W				
R903	1-249-429-11	CARBON	10K	5%	1/4W				
R904	1-249-429-11	CARBON	10K	5%	1/4W				
R905	1-247-903-00	CARBON	1M	5%	1/4W				
R907	1-249-415-11	(WR720A).... CARBON	680	5%	1/4W				

Ref.No	Part No.	Description			
R908	1-249-415-11	(WR720A)... CARBON	680	5%	1/4W
R909	1-249-415-11	(WR720A)... CARBON	680	5%	1/4W
R910	1-249-415-11	(WR720A)... CARBON	680	5%	1/4W
R918	1-249-413-11	CARBON	470	5%	1/4W
R919	1-249-437-11	CARBON	47K	5%	1/4W
R920	1-249-437-11	CARBON	47K	5%	1/4W
R921	1-249-407-11	CARBON	150	5%	1/4W
R922	1-249-409-11	CARBON	220	5%	1/4W
R923	1-249-411-11	CARBON	330	5%	1/4W
R924	1-249-413-11	CARBON	470	5%	1/4W
R925	1-249-415-11	CARBON	680	5%	1/4W
R926	1-249-417-11	CARBON	1K	5%	1/4W
R927	1-249-420-11	CARBON	1.8K	5%	1/4W
R928	1-249-424-11	CARBON	3.9K	5%	1/4W
R929	1-249-407-11	CARBON	150	5%	1/4W
R930	1-249-409-11	CARBON	220	5%	1/4W
R931	1-249-411-11	CARBON	330	5%	1/4W
R932	1-249-413-11	CARBON	470	5%	1/4W
R933	1-249-415-11	CARBON	680	5%	1/4W
R934	1-249-417-11	CARBON	1K	5%	1/4W
R935	1-249-420-11	CARBON	1.8K	5%	1/4W
R936	1-249-424-11	CARBON	3.9K	5%	1/4W
R937	1-249-407-11	CARBON	150	5%	1/4W
R938	1-249-409-11	CARBON	220	5%	1/4W
R939	1-249-411-11	CARBON	330	5%	1/4W
R940	1-249-413-11	CARBON	470	5%	1/4W
R941	1-249-415-11	CARBON	680	5%	1/4W
R942	1-249-417-11	CARBON	1K	5%	1/4W
R943	1-249-420-11	CARBON	1.8K	5%	1/4W
R944	1-249-424-11	(WR720)... CARBON	3.9K	5%	1/4W
R946	1-249-430-11	CARBON	12K	5%	1/4W
R948	1-249-430-11	CARBON	12K	5%	1/4W
R950	1-249-430-11	(WR720)... CARBON	12K	5%	1/4W
R951	1-249-433-11	CARBON	22K	5%	1/4W
R952	1-249-437-11	CARBON	47K	5%	1/4W
R953	1-249-437-11	CARBON	47K	5%	1/4W
R954	1-249-424-11	CARBON	3.9K	5%	1/4W
R961	1-249-429-11	CARBON	10K	5%	1/4W
R963	1-249-431-11	(WR720)... CARBON	15K	5%	1/4W
R0391	1-249-430-11	CARBON	12K	5%	1/4W
R0392	1-247-883-00	CARBON	150K	5%	1/4W
R0393	1-249-393-11	CARBON	10	5%	1/4W
R0394	1-249-431-11	CARBON	15K	5%	1/4W
R0395	1-247-864-11	CARBON	24K	5%	1/4W
R0491	1-249-430-11	CARBON	12K	5%	1/4W
R0492	1-247-883-00	CARBON	150K	5%	1/4W
R0493	1-249-393-11	CARBON	10	5%	1/4W
R0494	1-249-431-11	CARBON	15K	5%	1/4W
R0495	1-247-864-11	CARBON	24K	5%	1/4W
RV11	1-238-597-11	RES, ADJ. CARBON 1K			
RV21	1-238-597-11	RES, ADJ. CARBON 1K			
RV71	1-238-600-11	RES, ADJ. CARBON 10K			
RV72	1-238-600-11	RES, ADJ. CARBON 10K			
RV121	1-238-600-11	RES, ADJ. CARBON 10K			
RV122	1-238-600-11	RES, ADJ. CARBON 10K			
RV221	1-238-600-11	RES, ADJ. CARBON 10K			
RV222	1-238-600-11	RES, ADJ. CARBON 10K			
RV391	1-230-497-11	RES, ADJ. CARBON 22K			
RV491	1-230-497-11	RES, ADJ. CARBON 22K			

Ref.No	Part No.	Description
RV501	1-238-953-11	(WR720)... RES, VAR, CARBON 50K/50K (BALANCE)
RV502	1-241-133-11	(WR720)... RES, VAR, CARBON 50K/50K (REC LEVEL)
RV503	1-238-085-11	(WR720)... RES, VAR, CARBON 20K/20K (PHONES LEVEL)
RV901	1-241-058-11	(WR720A)... RES, VAR, CARBON 50K/50K (REC LEVEL)
RV901	1-241-134-11	(WR720)... RES, VAR, CARBON 20K (BIAS (DECK B))
RV902	1-241-057-11	(WR720A)... RES, VAR, CARBON 50K/50K (BALANCE)
RV0391	1-230-497-11	RES, ADJ. CARBON 22K
RV0491	1-230-497-11	RES, ADJ. CARBON 22K
RY31	1-515-726-11	RELAY
S81	1-571-958-11	SWITCH, PUSH (1 KEY) (STOP DET)
S82	1-571-281-21	SWITCH, LEAF (CO <sub>2</sub> DET)
S83	1-571-281-21	SWITCH, LEAF (METAL DET)
S84	1-571-281-21	SWITCH, LEAF (ERASE PROOF (SIDE A))
S85	1-571-281-21	SWITCH, LEAF (ERASE PROOF (SIDE B))
S86	1-571-281-21	SWITCH, LEAF (HALF DET)
S87	1-572-393-11	SWITCH, LEAF (DIRECTION)
S701	△.1-571-305-11	SWITCH, PUSH (1 KEY) (POWER)
S702	△.1-570-307-11	(E)... SWITCH, VOLTAGE CHANGE (VOLTAGE SELECTOR)
S901	1-554-303-21	SWITCH, KEY BOARD (SYNCHRO DUBBING HIGH SPEED)
S902	1-554-303-21	SWITCH, KEY BOARD (SYNCHRO DUBBING NORM SPEED)
S903	1-554-303-21	SWITCH, KEY BOARD (A+B REC)
S904	1-554-303-21	SWITCH, KEY BOARD (AUTO PAUSE)
S905	1-554-303-21	SWITCH, KEY BOARD (BLANK SKIP)
S906	1-554-303-21	(WR720)... SWITCH, KEY BOARD (COUNTER A/B)
S906	1-554-303-21	(WR720A)... SWITCH, KEY BOARD (COUNTER RESET)
S907	1-554-303-21	(WR720)... SWITCH, KEY BOARD (COUNTER RESET)
S907	1-554-303-21	(WR720A)... SWITCH, KEY BOARD (COUNTER MEMORY)
S908	1-554-303-21	(WR720)... SWITCH, KEY BOARD (COUNTER MEMORY)
S908	1-554-303-21	(WR720A)... SWITCH, KEY BOARD (COUNTER A/B)
S909	1-554-303-21	SWITCH, KEY BOARD (■ (DECK B))
S910	1-554-303-21	SWITCH, KEY BOARD (▷ (DECK B))
S911	1-554-303-21	SWITCH, KEY BOARD (◁ (DECK B))
S912	1-554-303-21	SWITCH, KEY BOARD (PAUSE    (DECK B))
S913	1-554-303-21	SWITCH, KEY BOARD (REC MUTE ○ (DECK B))
S914	1-554-303-21	SWITCH, KEY BOARD (◀ (AMS)(DECK A))
S915	1-554-303-21	SWITCH, KEY BOARD ((AMS) ▶▶ (DECK A))
S916	1-554-303-21	SWITCH, KEY BOARD (REC ● (DECK A))
S917	1-554-303-21	SWITCH, KEY BOARD (■ (DECK A))
S918	1-554-303-21	SWITCH, KEY BOARD (▷ (DECK A))
S919	1-554-303-21	SWITCH, KEY BOARD (◁ (DECK A))
S920	1-554-303-21	SWITCH, KEY BOARD (PAUSE    (DECK A))
S921	1-554-303-21	SWITCH, KEY BOARD (REC MUTE ○ (DECK A))
S922	1-554-303-21	SWITCH, KEY BOARD (◀ (AMS)(DECK B))
S923	1-554-303-21	SWITCH, KEY BOARD ((AMS) ▶▶ (DECK B))
S924	1-554-303-21	SWITCH, KEY BOARD (REC ● (DECK B))

<p><b>Note:</b> The components identified by mark <b>△</b> or dotted line with mark <b>△</b> are critical for safety. Replace only with part number specified.</p>	<p><b>Note:</b> Les composants identifiés par une marque <b>△</b> sont critiques pour la sécurité. Ne les remplacer que par une pièce portant le numéro spécifié.</p>
--	---

Ref.No	Part No.	Description
S925	1-571-520-11	(WR720)...SWITCH, SLIDE (DIR MODE)
S925	1-572-401-11	(WR720A)...SWITCH, SLIDE (DIR MODE)
S926	1-571-520-11	(WR720)...SWITCH, SLIDE (DOLBY NR)
S926	1-572-401-11	(WR720A)...SWITCH, SLIDE (DOLBY NR)
S927	1-571-520-11	(WR720)...SWITCH, SLIDE (TIMER)
T51	1-433-366-11	TRANSFORMER, BIAS OSCILLATION
T391	1-433-367-11	TRANSFORMER, BIAS OSCILLATION
T491	1-433-367-11	TRANSFORMER, BIAS OSCILLATION
T701	△1-450-147-11	(US, Canadian)...TRANSFORMER, POWER
T701	△1-450-148-11	(AEP, WG)...TRANSFORMER, POWER
T701	△1-450-191-11	(E)...TRANSFORMER, POWER
T0391	1-433-367-11	TRANSFORMER, BIAS OSCILLATION
T0491	1-433-367-11	TRANSFORMER, BIAS OSCILLATION
TP1	*1-564-505-11	PLUG, CONNECTOR 2P
TP691	*1-564-520-11	PLUG, CONNECTOR 5P
TP0691	*1-564-520-11	PLUG, CONNECTOR 5P
X801	1-577-358-21	VIBRATOR, CERAMIC (4MHz)
X901	1-577-358-21	VIBRATOR, CERAMIC (4MHz)

ACCESSORIES & PACKING MATERIALS

\*\*\*\*\*

1-463-974-11	(E)...REMOTE COMMANDER (RM-900W)
1-559-533-11	CORD, CONNECTION
△1-569-007-11	(E)...ADAPTER, CONVERSION 2P
*3-354-918-21	INDIVIDUAL CARTON
*3-359-942-01	CUSHION
3-703-450-01	(US)...INSTRUCTION
*3-703-710-41	STICKER, SONY SYMBOL (12)
3-751-915-21	(WR720A)...MANUAL, INSTRUCTION (ENGLISH)
3-751-915-31	(Canadian, E)...MANUAL, INSTRUCTION (FRENCH)
3-751-921-11	(AEP)...MANUAL, INSTRUCTION (ENGLISH, FRENCH, SPANISH, PORTUGUESE)
3-751-921-41	(AEP)...MANUAL, INSTRUCTION (GERMAN, DUTCH, SWEDISH, ITALIAN)
3-751-921-51	(WG)...MANUAL, INSTRUCTION (GERMAN)

**Note:**  
The components identified by mark △ or dotted line with mark △ are critical for safety. Replace only with part number specified.

**Note:**  
Les composants identifiés par une marque △ sont critiques pour la sécurité. Ne les remplacer que par une pièce portant le numéro spécifié.



# TC-WR720/WR720A

## SONY® SERVICE MANUAL

*US Model*  
*Canadian Model*  
*E Model*  
TC-WR720A  
*AEP Model*  
TC-WR720

## SUPPLEMENT-1

File this supplement with the Service Manual.

Subject: block diagram

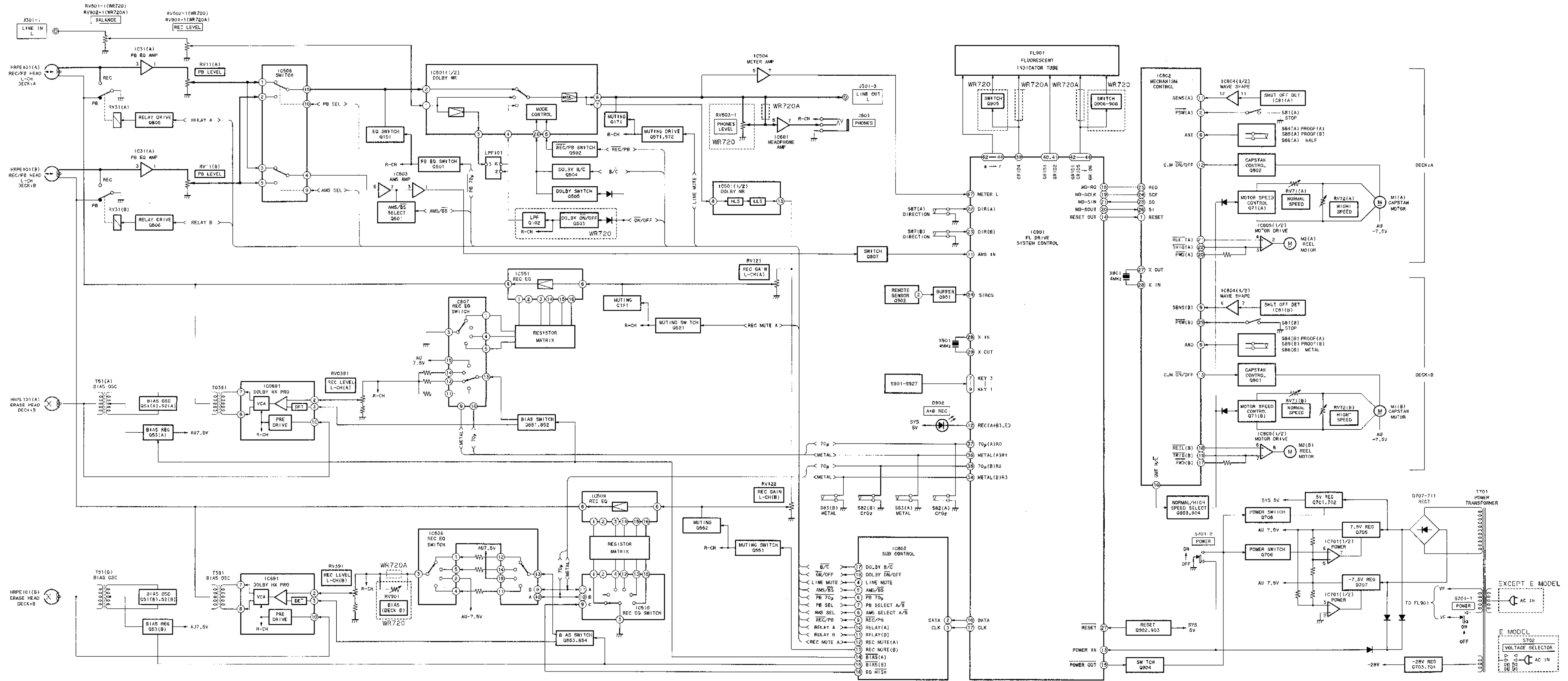

# TC-WR720 / WR720A

## SONY SERVICE MANUAL



US Model  
Canadian Model  
E Model  
TC-WR720A

AEP Model  
TC-WR720

### CORRECTION-1

Correct your service manual as shown below.

 : indicates corrected portion.

Page	INCORRECT	CORRECT
10	<p>Playback Level Adjustment</p> <p>: : : :</p> <p>Adjustment limits : LINE OUT level : <math>-15 \pm 0.5\text{dB}</math>(0.130 to 0.146V)</p>	<p>Playback Level Adjustment</p> <p>: : : :</p> <p>Adjustment limits : LINE OUT level : <math>-5 \pm 0.5\text{dB}</math>(<u>0.411 to 0.462V</u>)</p> <p> </p>