

TC-WR535

SERVICE MANUAL

US Model
Canadian Model
AEP Model
UK Model
E Model
Australian Model

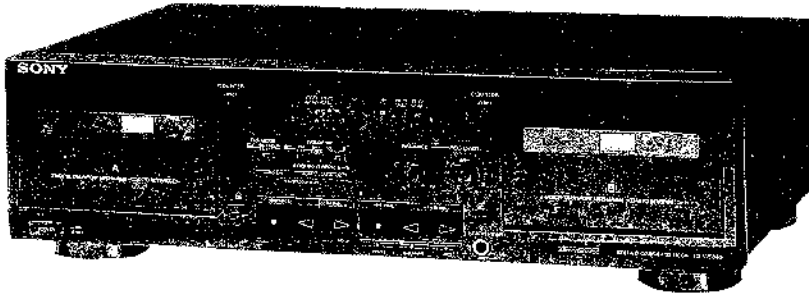

SPECIFICATIONS

Recording system 4-track 2-channel stereo
 Fast winding time Approx. 90 sec. (with Sony C-60 cassette)
 Bias AC bias
 Signal-to-noise ratio (at peak level and weighted)

Cassette (Dolby NR off)	Type IV	Type II	Type I
	58 dB	57 dB	55 dB

S/N ratio improvement (approximate values)
 With Dolby B NR on: 5 dB at 1 kHz; 10 dB at 5 kHz
 With Dolby C NR on: 15 dB at 500 Hz; 20 dB at 1 kHz

Harmonic distortion
 0.4% (with Type I, 160 nWb/m, 315 Hz, 3rd H.D.)
 1.8% (with Type IV, 250 nWb/m, 315 Hz, 3rd H.D.)

Frequency response (Dolby NR off)

Cassette Model	Type IV cassette	Type II cassette	Type I cassette
TC-WR535	30 - 18,000 Hz (±3 dB, IEC) 30 - 13,000 Hz [±3 dB (-4 dB) recording]	30 - 17,000 Hz (±3 dB, IEC)	30 - 15,000 Hz (±3 dB, IEC)

Type IV : Sony ES-IV
 Type II : Sony UX-S or UX
 Type I : Sony HF-S

Model Name Using Similar Mechanism	TC-WR521/WR590	
Tape Transport Mechanism Type	DECK A	TCM-190RA12C
	DECK B	TCM-190RB12C

Wow and flutter TC-WR535
 ±0.14% W.Peak (IEC)
 0.08% W.RMS (NAB)
 ±0.19% W.Peak (DIN)

Inputs

Line inputs (phono jacks)	Sensitivity	0.16 V
	Input impedance	47 k ohms

... Continued on page 2 -

Dolby noise reduction manufactured under license from
 Dolby Laboratories Licensing Corporation.
 "DOLBY" and the double-D symbol  are trademarks of
 Dolby Laboratories Licensing Corporation.

STEREO CASSETTE DECK
SONY®

Outputs

Line outputs (phono jacks)	Rated output level	0.5 V at a load impedance of 47 k ohms
	Load impedance	Over 10 k ohms
Headphones (stereo phone jack)	Output level	1 mW at a load impedance of 32 ohms

General

Power requirements US, Canadian model :
120V AC, 60Hz
UK, Australian model :
240V AC, 50/60Hz
AEP, Germany model :
220-230V AC, 50/60Hz
E model : 120, 220, 240V AC, 50/60Hz

Power consumption 25 W

Dimensions Approx. 430 × 123 × 310 mm
(w/h/d)
(17 × 4 7/8 × 12 1/4 inches) including
projecting parts and controls

Mass Approx. 4.5 kg (9 lbs 15 oz)

Supplied accessories

Audio connecting cords (2)

Note

This appliance conforms with EEC Directive 87/308 EEC regarding interference suppression.

Design and specifications are subject to change without notice.

TABLE OF CONTENTS

<i>Section</i>	<i>Title</i>	<i>Page</i>
	specifications	1
	Safety Check-out	3
1. GENERAL		
1-1.	Identifying the Parts	4
2. DISASSEMBLY		
2-1.	Front Panel	5
2-2.	Mechanism Deck	5
2-3.	Capstan Motor, Reel Motor	6
2-4.	Head, Pinch Roller	6
3. ADJUSTMENTS		
3-1.	Mechanical Adjustments	7
3-2.	Electrical Adjustments	7
4. EXPLANATION OF IC TERMINALS		11
5. DIAGRAMS		
5-1.	Block Diagram	14
5-2.	Circuit Board Location	16
5-3.	Printed Wiring Boards	18
5-4.	Schematic Diagram (Main Section)	23
5-5.	Schematic Diagram (Audio Section)	28
6. EXPLODED VIEWS		
6-1.	Chassis Section	33
6-2.	Front Panel Section	34
6-3.	Mechanism Section 1	35
6-4.	Mechanism Section 2	36
7. ELECTRICAL PARTS LIST		37

MODEL IDENTIFICATION
(Specification Label)

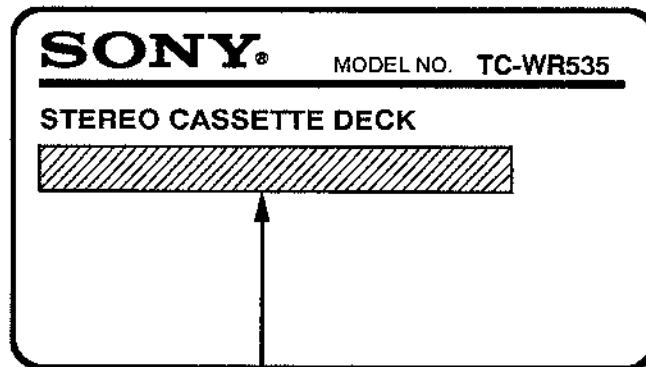

US, Canadian model : AC 120V 60Hz
UK, Australian model : AC 240V~50/60Hz
AEP, Germany model : AC 220-230V~50/60Hz
E model : AC120, 220, 240V~50/60Hz

SAFETY CHECK-OUT

After correcting the original service problem, perform the following safety check before releasing the set to the customer:

Check the antenna terminals, metal trim, "metallized" knobs, screws, and all other exposed metal parts for AC leakage. Check leakage as described below.

LEAKAGE TEST

The AC leakage from any exposed metal part to earth ground and from all exposed metal parts to any exposed metal part having a return to chassis, must not exceed 0.5 mA (500 microamperes). Leakage current can be measured by any one of three methods.

1. A commercial leakage tester, such as the Simpson 229 or RCA WT-540A. Follow the manufacturers' instructions to use these instruments.
2. A battery-operated AC milliammeter. The Data Precision 245 digital multimeter is suitable for this job.

3. Measuring the voltage drop across a resistor by means of a VOM or battery-operated AC voltmeter. The "limit" indication is 0.75 V, so analog meters must have an accurate low-voltage scale. The Simpson 250 and Sanwa SH-63Trd are examples of a passive VOM that is suitable. Nearly all battery operated digital multimeters that have a 2V AC range are suitable. (See Fig. A)

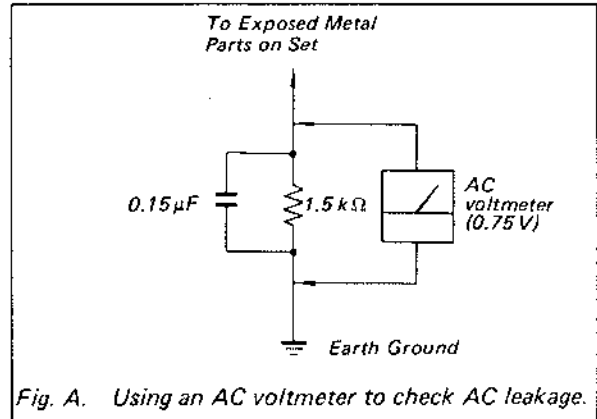

Fig. A. Using an AC voltmeter to check AC leakage.

SAFETY-RELATED COMPONENT WARNING!!

COMPONENTS IDENTIFIED BY MARK \triangle OR DOTTED LINE WITH MARK \triangle ON THE SCHEMATIC DIAGRAMS AND IN THE PARTS LIST ARE CRITICAL TO SAFE OPERATION. REPLACE THESE COMPONENTS WITH SONY PARTS WHOSE PART NUMBERS APPEAR AS SHOWN IN THIS MANUAL OR IN SUPPLEMENTS PUBLISHED BY SONY.

ATTENTION AU COMPOSANT AYANT RAPPORT À LA SÉCURITÉ!

LES COMPOSANTS IDENTIFIÉS PAR UNE MARQUE \triangle SUR LES DIAGRAMMES SCHÉMATIQUES ET LA LISTE DES PIÈCES SONT CRITIQUES POUR LA SÉCURITÉ DE FONCTIONNEMENT. NE REMPLACER CES COMPOSANTS QUE PAR DES PIÈCES SONY DONT LES NUMÉROS SONT DONNÉS DANS CE MANUEL OU DANS LES SUPPLÉMENTS PUBLIÉS PAR SONY.

SECTION 1 GENERAL

This section is extracted from instruction manual.

1-1. IDENTIFYING THE PARTS

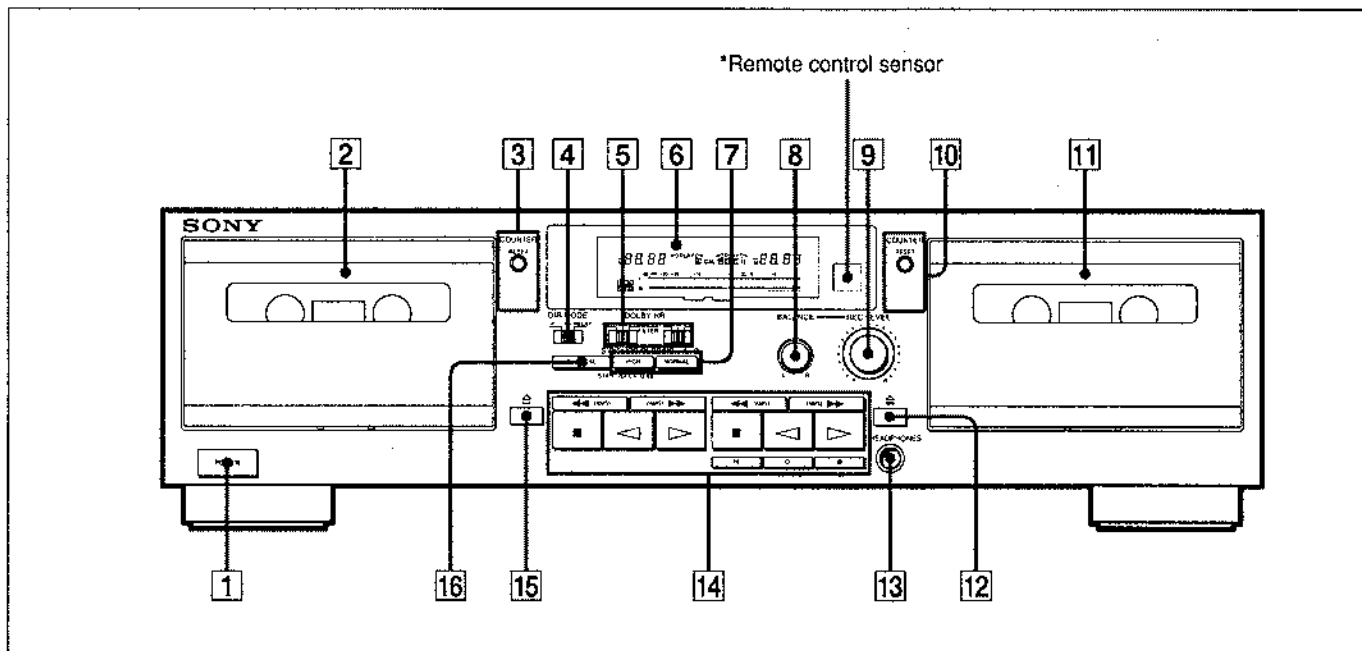

Front Panel



For details, refer to the page number(s) indicated in parentheses.

- 1 POWER switch
- 2 Deck A
- 3 COUNTER buttons (deck A)
RESET button
- 4 DIR (direction) MODE switch
- 5 DOLBY NR (Dolby noise reduction) switches
OFF/ON/FILTER ON switch
B/C switch
- 6 Display panel
- 7 SYNCHRO DUBBING buttons
HIGH button
NORMAL button
- 8 BALANCE control
- 9 REC (recording) LEVEL control
- 10 COUNTER buttons (deck B)
RESET button
- 11 Deck B
- 12 ▲ (eject) button (deck B)
- 13 HEADPHONES jack (stereo phone jack)
- 14 Tape operation buttons
◀◀ (leftward fast winding) (Multi-AMS**) button
▶▶ (rightward fast winding) (Multi-AMS**) button
■ (stop) button
◀ (reverse play) button
▶ (forward play) button
|| PAUSE button (deck B only)
○ REC MUTE (record muting) button (deck B only)
● REC (recording) button (deck B only)
- 15 ▲ (eject) button (deck A)
- 16 AUTO CAL button

*Remote control sensor

- You can remotely control this cassette deck with:
- A remote commander that came with a Sony amplifier or receiver if it has the  mark and cassette deck control capability.
 - Any optional Sony remote commander with the  mark and cassette deck control capability.

** AMS is an abbreviation for Automatic Music Sensor.

SECTION 2 DISASSEMBLY

Note : Follow the disassembly procedure in the numerical order given.

CASE
Unscrew the four case attachment screws M3 × 8 and remove the case.

2-1. FRONT PANEL

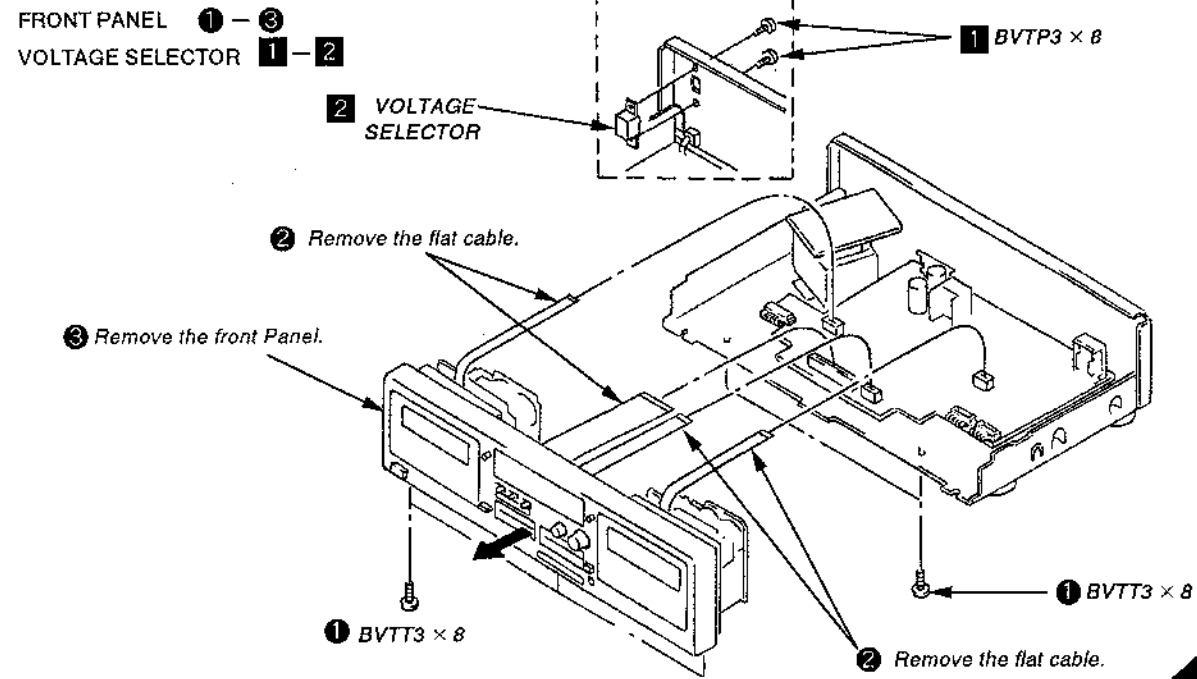

2-2. MECHANISM DECK

① Press the EJECT button.

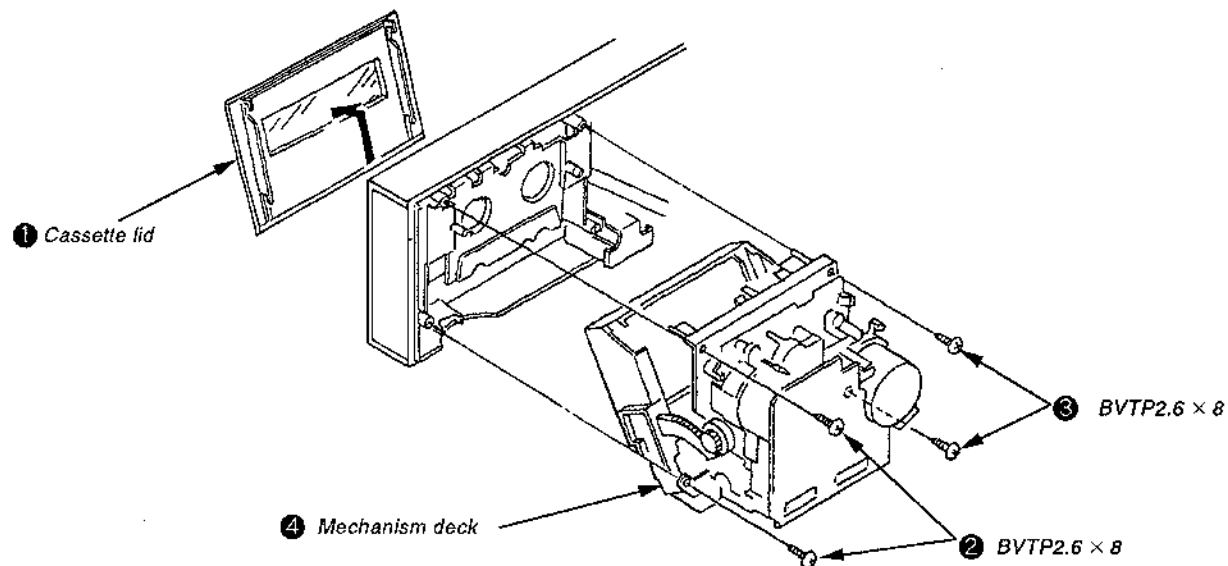

2-3. CAPSTAN MOTOR, REEL MOTOR

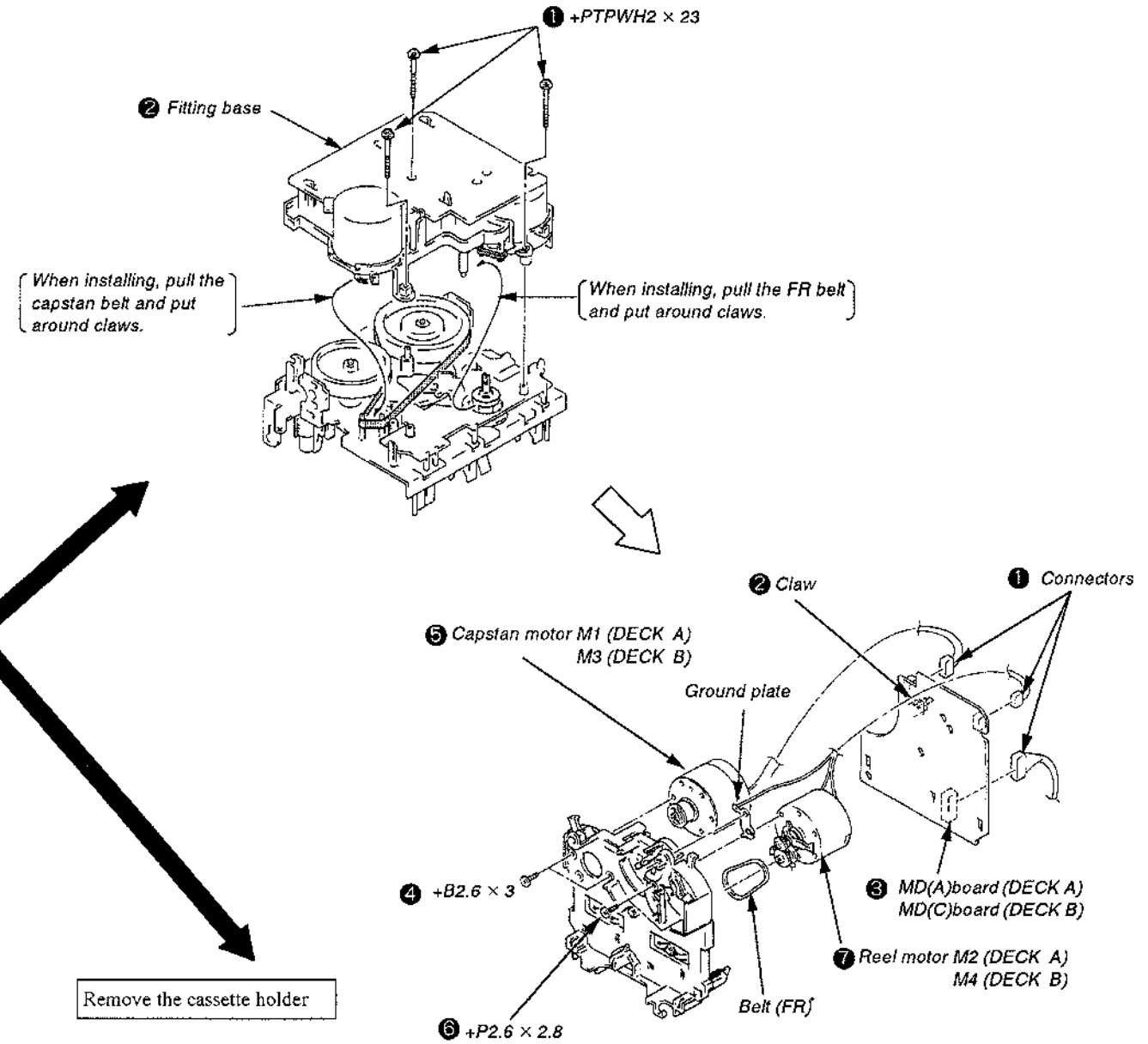

2-4. HEAD, PINCH ROLLER

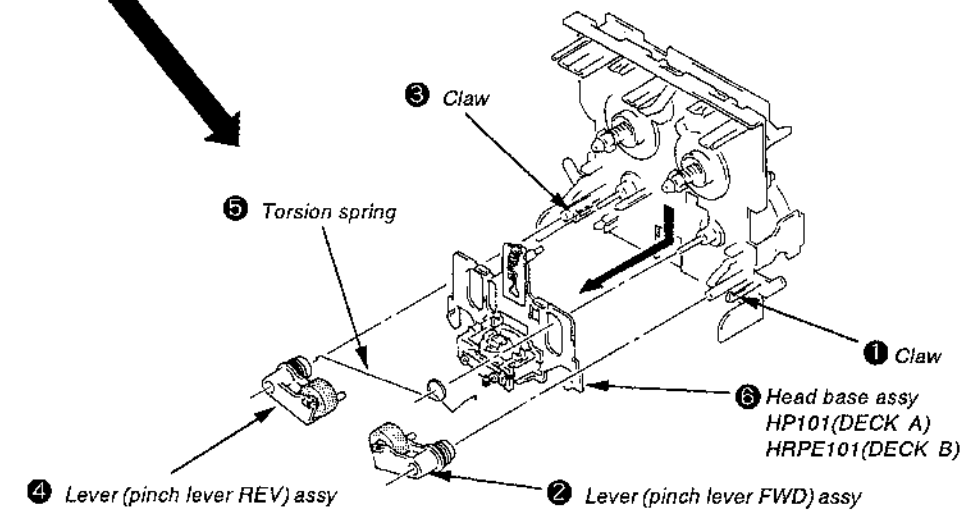

SECTION 3 ADJUSTMENTS

3-1. MECHANICAL ADJUSTMENTS

PRECAUTION

1. Clean the following parts with a denatured alcohol-moistened swab:

record/playback/erase head	pinch roller
rubber belts	capstan
idlers	
2. Demagnetize the record/playback head with a head demagnetizer. (Head demagnetizer do not approach for the erase head.)
3. Do not use a magnetized screwdriver for the adjustment.
4. After the adjustments, apply suitable locking compound to the parts adjusted.
5. The adjustments should be performed with the rated power supply voltage unless otherwise noted.

Torque Measurement

Torque	Torque	Meter reading
Forward	CQ-102C	30 to 65g • cm (0.42 to 0.9 oz • inch)
Forward back tension	CQ-102C	DECK A : 1 to 6g • cm (0.014 to 0.083 oz • inch) DECK B : 2 to 9g • cm (0.03 to 0.12 oz • inch)
Reverse	CQ-102RC	30 to 65g • cm (0.42 to 0.9 oz • inch)
Reverse back tension	CQ-102RC	1 to 6g • cm (0.014 to 0.083 oz • inch)
FF/REW	CQ-201B	70 to 120g • cm (0.98 to 1.66 oz • inch)

3-2. ELECTRICAL ADJUSTMENTS

PRECAUTION

1. The adjustment should be performed in the publication. (Be sure to make playback adjustment at first.)
2. The adjustments and measurement should be performed for both L-CH and R-CH.
 - Switch position

DOLBY NR switch	: OFF
DIR MODE switch	: ⇄
 - Standard record position :

Deliver the standard input signal level to input jack and set the REC LEVEL control to obtain the standard output signal level as follows.

— Record Mode —

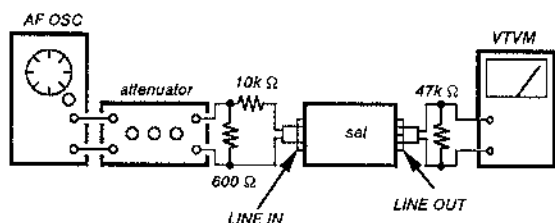

Standard Input Level

Input terminal	LINE IN
source impedance	10k Ω
input signal level	0.5V (- 3.8dB)

Standard Output Level

Output terminal	LINE OUT
load impedance	47k Ω
output signal level	0.5V (- 3.8dB)

Test Tape

Tape	Contents	Use
P-4-A100	10kHz, - 10dB	Azimuth Adjustment
P-4-L300	315Hz, 0dB	PB Level Adjustment
WS-48B	3kHz, 0dB	Tape Speed Adjustment

$$0\text{dB} = 0.775\text{V}$$

Test Mode

1. Insert a short-circuit plug into TP801 (2P) and turn ON the power switch. (Earth pin Ⓣ of IC801 and turn ON the power switch.)
At first, all the fluorescent tubes light up, then the system returns to normal display. (However, "0000" is not displayed on the counter.)
2. To release the test mode, remove the short plug and turn off the power switch.
3. Remove the short plug after completion of adjustment.

Record/Playback Head Azimuth Adjustment

Procedure :

1. Forward playback Mode

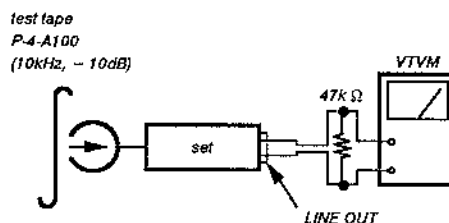

2. Turn the adjustment screw for the maximum output levels. If these levels do not match, turn the adjustment screw until both of output levels match together within 1dB.

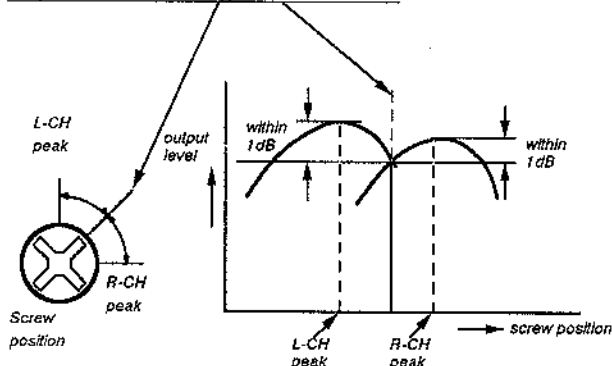

3. Playback Mode

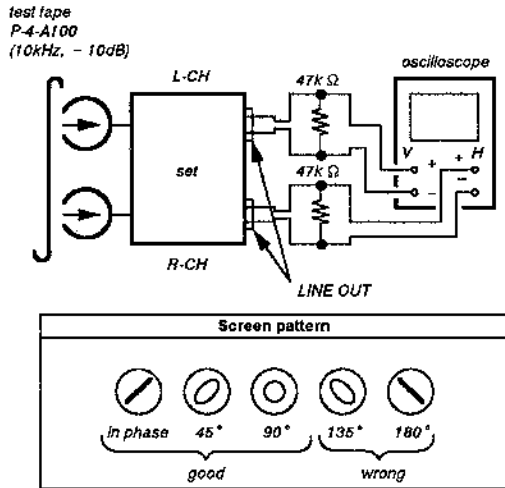

4. Change the reverse playback mode and repeat the steps 1 to 3.
5. After the adjustment, lock the adjustment screws with suitable locking compound.

Adjustment Location : – record/playback head –

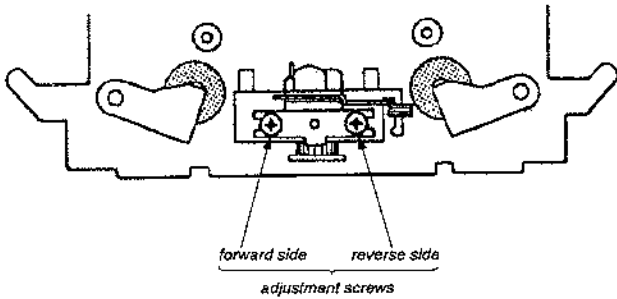

Tape Speed Adjustment

Procedure :

– Forward Playback Mode –

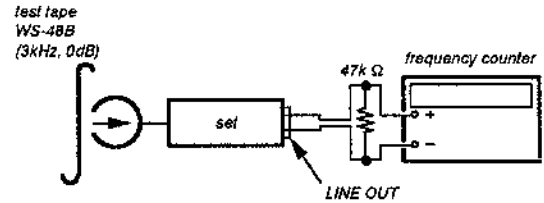

(high speed adjustment)

1. Connect ⑩ pin of IC801 to ground.
2. Set to FWD playback mode.
3. Keep on pressing the HIGH SPEED DUBBING switch.
4. Adjust RV72 so that the frequency counter reading becomes $6,000 \pm 20\text{Hz}$.

(normal speed adjustment)

1. Set to FWD playback mode.
2. Adjust RV71 so that the frequency counter reading becomes $3,000 \pm 10\text{Hz}$.

Frequency difference between the beginning and the end of the tape should be within 3%.

Frequency difference between the deck A and deck B the beginning of the tape should be within 1.5%.

Adjustment Location : AUDIO board

Playback Level Adjustment

Procedure :

– Forward Playback Mode –

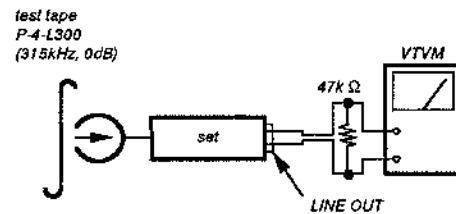

Adjust RV11(L-CH) and RV21(R-CH) so the VTVM reading becomes the adjustment limits below.

Adjustment Value :

LINE OUT level : – $7.7 \pm 0.5\text{dB}$ (0.301 to 0.338V)

Level difference between channels : within 0.5dB

Confirm the LINE OUT level does not change in playback mode while changing the mode from playback to stop several times.

Adjustment Location : AUDIO board

Bias Consumption Current Adjustment

This adjustment should be performed when replacing the head assy or the bias oscillating transformer (T81, T91).

Procedure :

() : R-CH

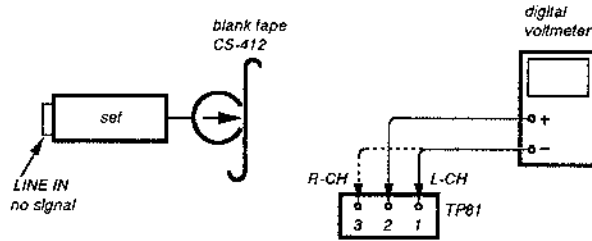

1. Connect the digital voltmeter to test point TP81.
2. Set RV81 (RV91) to mechanical center.
3. Set to FWD record mode.
4. Adjust T81 (T91) so that the digital voltmeter reading becomes minimum.

Adjustment Value : Maximum 220mV

Adjustment Location : AUDIO board

Record Bias Adjustment

Setting :

REC LEVEL control : standard record position (Refer to page 7.)

Procedure :

1. Record Mode

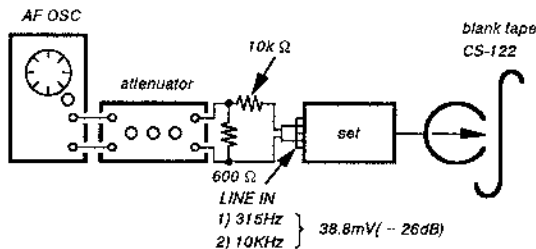

2. Playback Mode

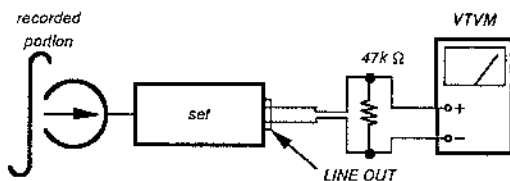

Confirm that the 10kHz playback output is $0 \pm 0.5\text{dB}$ relative to the 315Hz output. If necessary, adjust RV81(L-CH), RV91(R-CH) and repeat the steps given above.

Adjustment Location : AUDIO board

Record Level Adjustment

Setting :

REC LEVEL control : standard record position (Refer to page 7.)

Procedure :

1. Record Mode

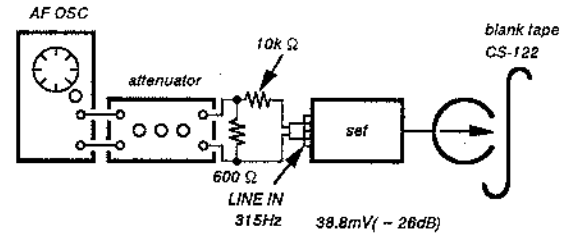

2. Playback Mode

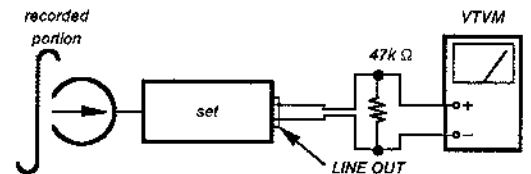

Confirm playback the tape recorded become adjustment level as follows.

If necessary, adjust RV131(L-CH), RV231(R-CH) and repeat the steps 1 and 2.

Adjustment Value :

LINE OUT level : $-26 \pm 0.5\text{dB}$ (36.7 to 41.1mV)

Adjustment Location : MAIN board

- Adjustment Parts Location Diagrams -

【MAIN BOARD】

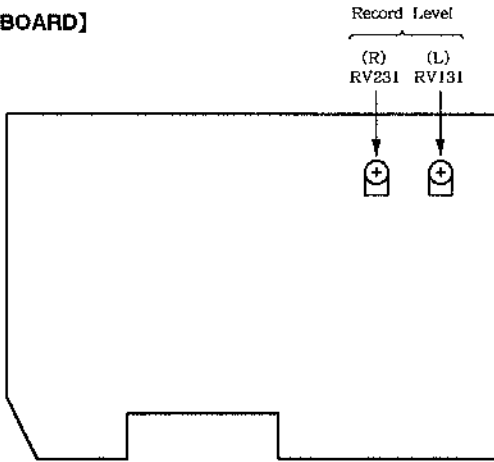

DECK A :

【AUDIO BOARD】

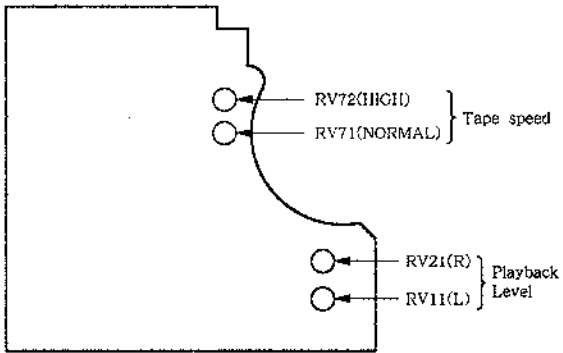

DECK B :

【AUDIO BOARD】

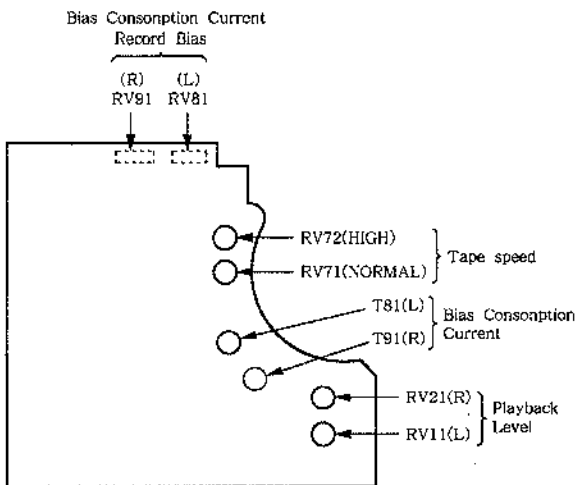

SECTION 4 EXPLANATION OF IC TERMINALS

IC801 CXP82316-017Q

Pin No.	Terminal name	I/O	Terminal explanation		
1	S. REEL(B)	I	(Port E) An 8-bit port of which the lower 6 bits are an input-only port and the upper 2 bits are an output-only port. (8lines)	External interrupt request input pines. (4 lines)	
78	STOP SW(A)	I			Timer/counter external event input pins .(2 lines)
79	STOP SW(B)	I			
80	S. REEL(A)	I			
2	SIRCS IN	I		Remote control reception circuit input pin.	
3	POWER IN	I			
4	$\overline{*1}/*2$	O			
5	PB SELECT $\overline{A/B}$	O		16-bit timer/counter square wave output pins.	
6	REC MUTE(B)	I/O	(Port B) The lower seven bits are an input/output port for which each bit can be set for input or output independently. The uppermost bit (PB7) is output only. (8 lines)	16-bit input pins for external capture to timer/counter.	
7	NR-CTRL2	I/O		Chip select input pin for serial interface (CH0)	
8	NR-CTRL1	I/O		Input/output pin for serial clock (CH0)	
9	\overline{CAL}	I/O		Input pin for serial data (CH0)	
10	REC OUT SELECT 1332/s	I/O		Output pin for serial data (CH0)	
11	DOLBY-S REC/PB	I/O		Input/output pin for serial clock (CH0)	
12	$\overline{BIAS (B)}$	I/O		Input pin for serial data (CH1)	
13	PLAY (B)	O		Output pin for serial data (CH1)	
14	REC CAL0	I/O	(Port C) 8-bit input/output port for which each bit can be set for input or output independently. Can drive a 12mA sync current.	Key return input pins for key scanning with FDP segment signals	
15	REC CAL1				
16	GP CAL0				
17	GP CAL1				
18	HALF (A)				
19	TEST				
20	METAL(B)				
21	70 μ (B)				
22	KEY 4	I/O	(Port A) 8-bit input port; each bit can be set for input or output independently. (8 lines)	Eight A/D converter analog input pins.	
23	KEY 3				
24	KEY 2				
25	KEY 1				
26	METER(L)				
27	METER(R)				
28	HALF(B)				
29	AMS IN				

Pin No.	Terminal name	I/O	Terminal explanation	
30	$\overline{\text{RESET}}$	I/O	Low active system reset pin; RESET is an input/output pin. When the power starts up, the internal power on reset function is triggered and low signal is output. (Mask option)	
31	EXTAL	O	Pins for connecting a crystal for the system clock oscillation. When using an external clock, input it to the EXTAL pin and input the reverse phase clock to the XTAL pin.	
32	XTAL	I		
33	V _{SS}	—	Ground pin.	
34	(LSB) BIAS CAL0	O	(Port D) 8-bit output-only port. (8 lines)	FDP segment signal output pins.
35	BAIS CAL1			
36	BAIS CAL2			
37	BAIS CAL3			
38	$\overline{\text{REC/PB}}$			
39	OSC $\overline{\text{ON/OFF}}$			
40	OSC F/L			
41	POWER OUT			
42	$\overline{\text{LIN MUTE}}$	O	(Port F) 8-bit output-only port. (8 lines)	FDP segment signal output pins.
43	C. MOT(NORMAL/ $\overline{\text{HI}}$)			
44	C. MOTOR(A)			
45	C. MOTOR(B)			
46	CAL. MUTE.			
47	P17			
48	P15			
49	P14	O	FDP segment signal output pins.	
50	P13			
51	P12			
52	P11			
53	P10			
54	P9	O	FDP timing signal and segment shared output pins.	
55	P8			
56	P7			
57	P6			
58	P5			
59	P4			
60	P3			
61	P2			
62	P1			

Pin No.	Terminal name	I/O	Terminal explanation
63	—	O	FDP timing signal output pins.
64	G1		
65	G2		
66	G4		
67	G5		
68	G3		
69	G7		
70	G6		
71	VFDP		Pin supplying the FDP voltage for setting the internal resistance with the mask option.
72	V _{DD}		Positive power supply pin.
73	—		This pin is not connected. In normal operation, connect to V _{DD} .
74	REEL MOTOR(A) +		(Port G) 4-bit input/output port for which each bit can be set for input or output independently.
75	REEL MOTOR(A) -		
76	REEL MOTOR(B) +		
77	REEL MOTOR(B) -		

SECTION 5 DIAGRAMS

5-1. BLOCK DIAGRAM

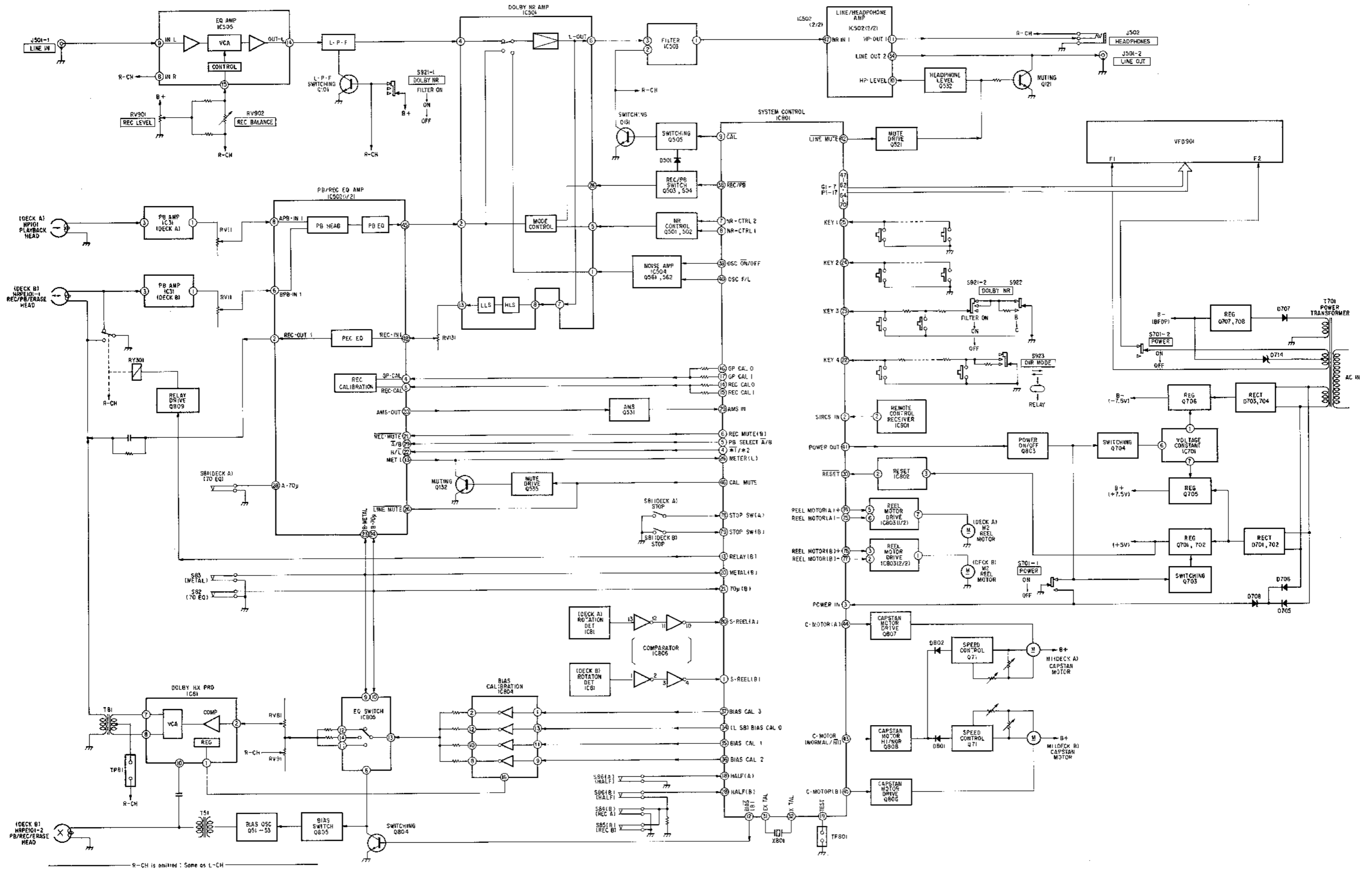

R-CH is omitted: Same as L-CH

5-2. CIRCUIT BOARD LOCATION

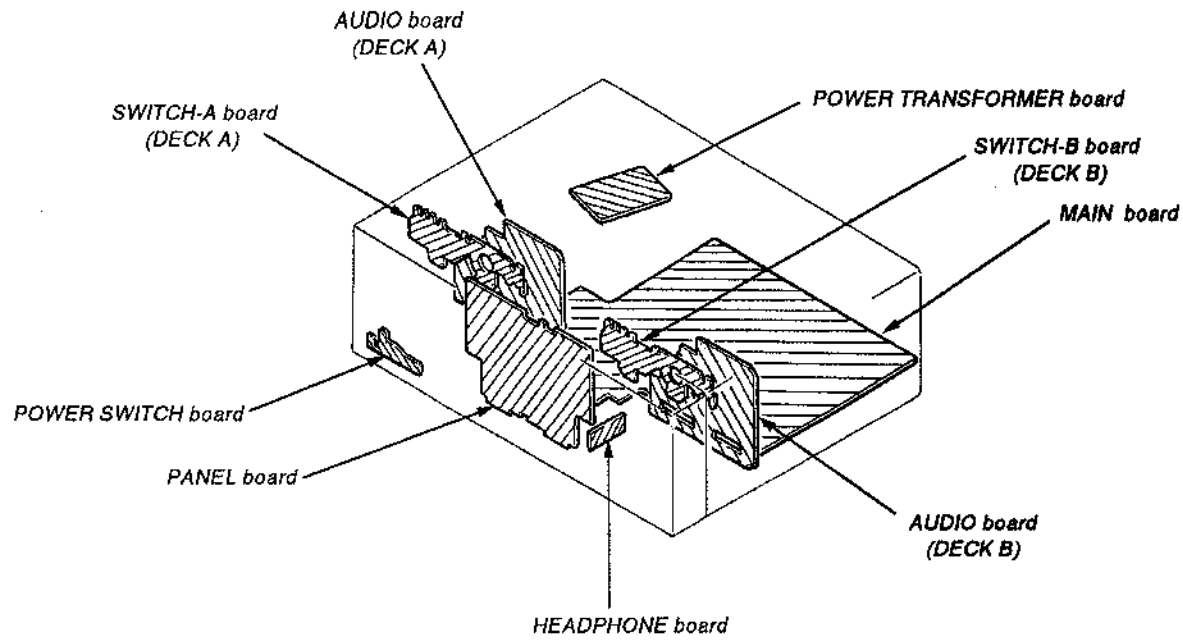

● SEMICONDUCTOR LEAD LAYOUTS

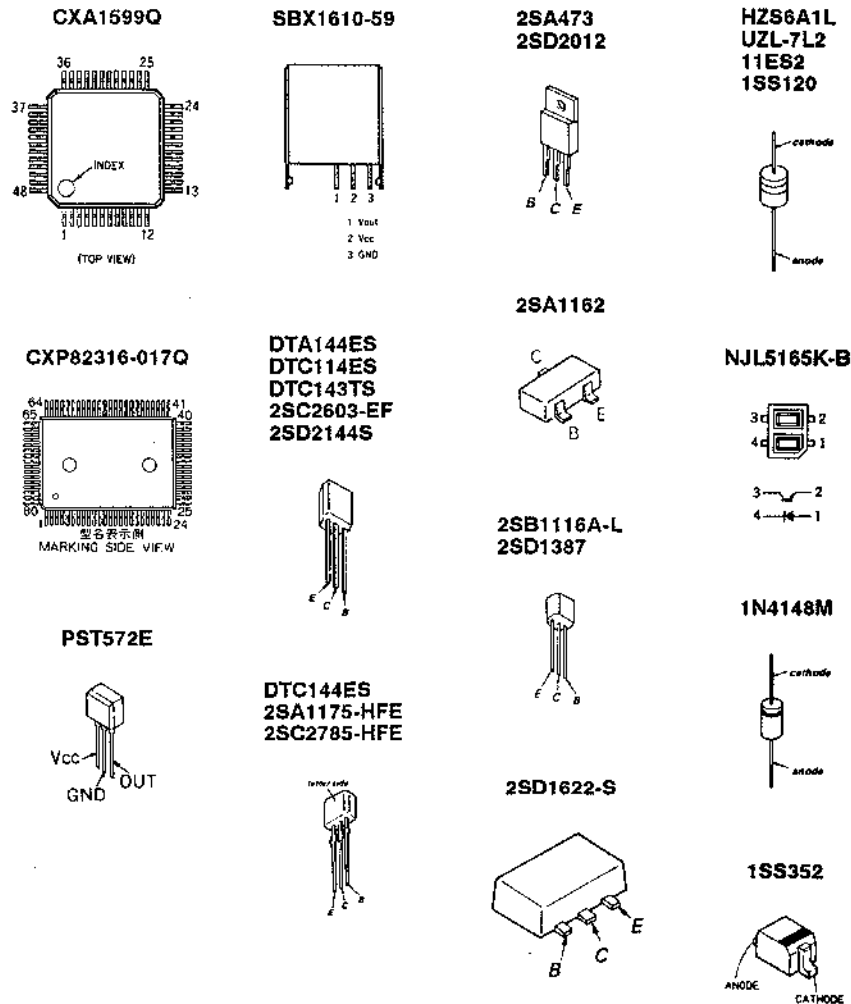

5-3. PRINTED WIRING BOARDS • Refer to page 16 for Semiconductor Lead Layouts.

• SEMICONDUCTOR LOCATION

Ref. No.	Location	Ref. No.	Location
D131	G-22	Q101	E-16
D231	G-22	Q121	B-18
D501	F-17	Q131	E-17
D502	E-18	Q132	E-22
D531	D-22	Q201	C-16
D561	B-13	Q221	B-17
D562	B-13	Q231	D-17
D701	B-23	Q232	E-21
D702	B-23	Q501	F-17
D703	C-23	Q502	F-17
D704	C-23	Q503	F-16
D705	B-23	Q504	F-16
D706	B-23	Q505	F-17
D707	D-23	Q521	B-18
D708	E-23	Q531	D-22
D709	B-23	Q532	F-19
D710	B-21	Q535	F-22
D711	C-21	Q581	B-13
D712	C-20	Q582	B-13
D713	D-22	Q701	B-22
D714	D-22	Q702	B-22
D715	B-24	Q703	B-23
D716	B-21	Q704	B-21
D801	G-13	Q705	B-21
D802	I-17	Q706	D-21
IC501	D-15	Q708	D-22
IC502	D-16	Q803	J-18
IC503	D-17	Q804	G-14
IC504	B-13	Q805	G-14
IC505	B-16	Q806	I-17
IC701	C-20	Q807	I-17
IC801	I-21	Q808	I-17
IC802	H-23	Q809	F-15
IC803	G-24	Q810	G-21
IC804	H-18		
IC805	H-15		
IC806	G-22		
IC901	J-32		

• SEMICONDUCTOR LOCATION (DECK A) • SEMICONDUCTOR LOCATION (DECK B)

Ref. No.	Location	Ref. No.	Location
IC31	D-3	D31	I-2
IC81	C-10	IC31	I-2
Q71	D-5	IC81	H-4 (AUDIO)
			H-9 (SW-A)
		Q51	H-3
		Q52	H-3
		Q53	H-3
		Q71	I-5

Note:
 ○ : parts extracted from the component side.
 ■ : parts mounted on the conductor side.
 ● : Through hole.
 ◌ : Pattern on the side which is seen.
 ◍ : Pattern of the rear side.
 □ : Chip components extracted from the rear side.
 G : Germany
 AUS : Australian

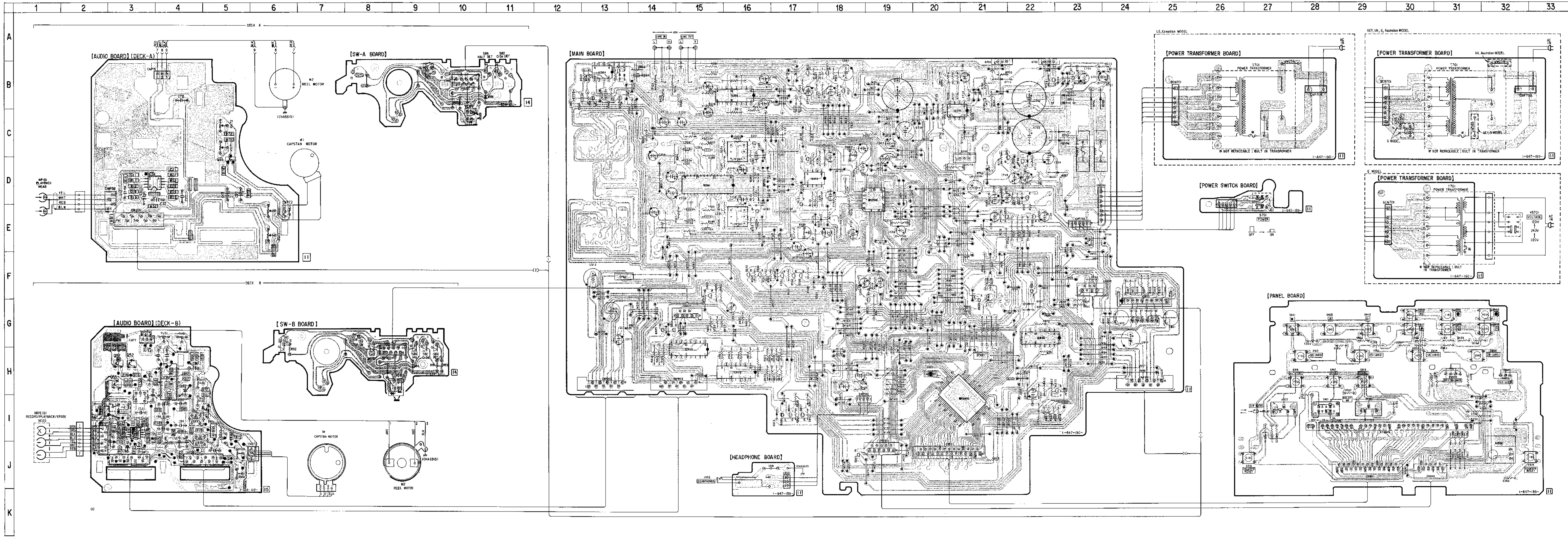

5-4. SCHEMATIC DIAGRAM (MAIN SECTION)

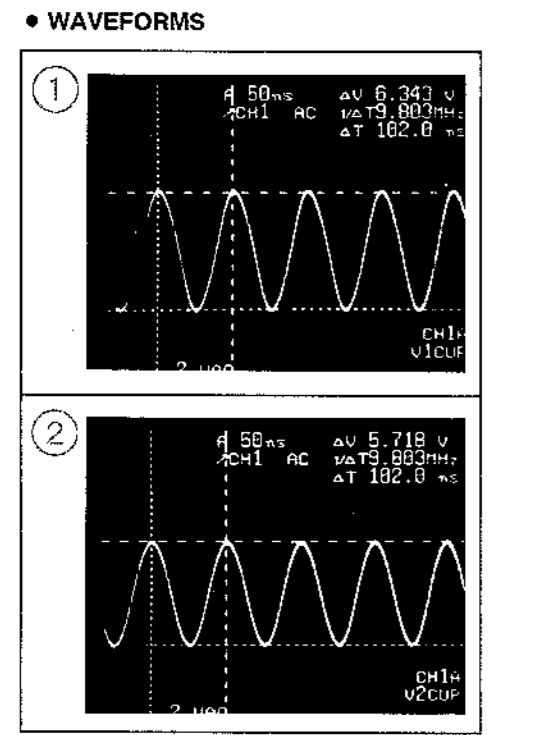
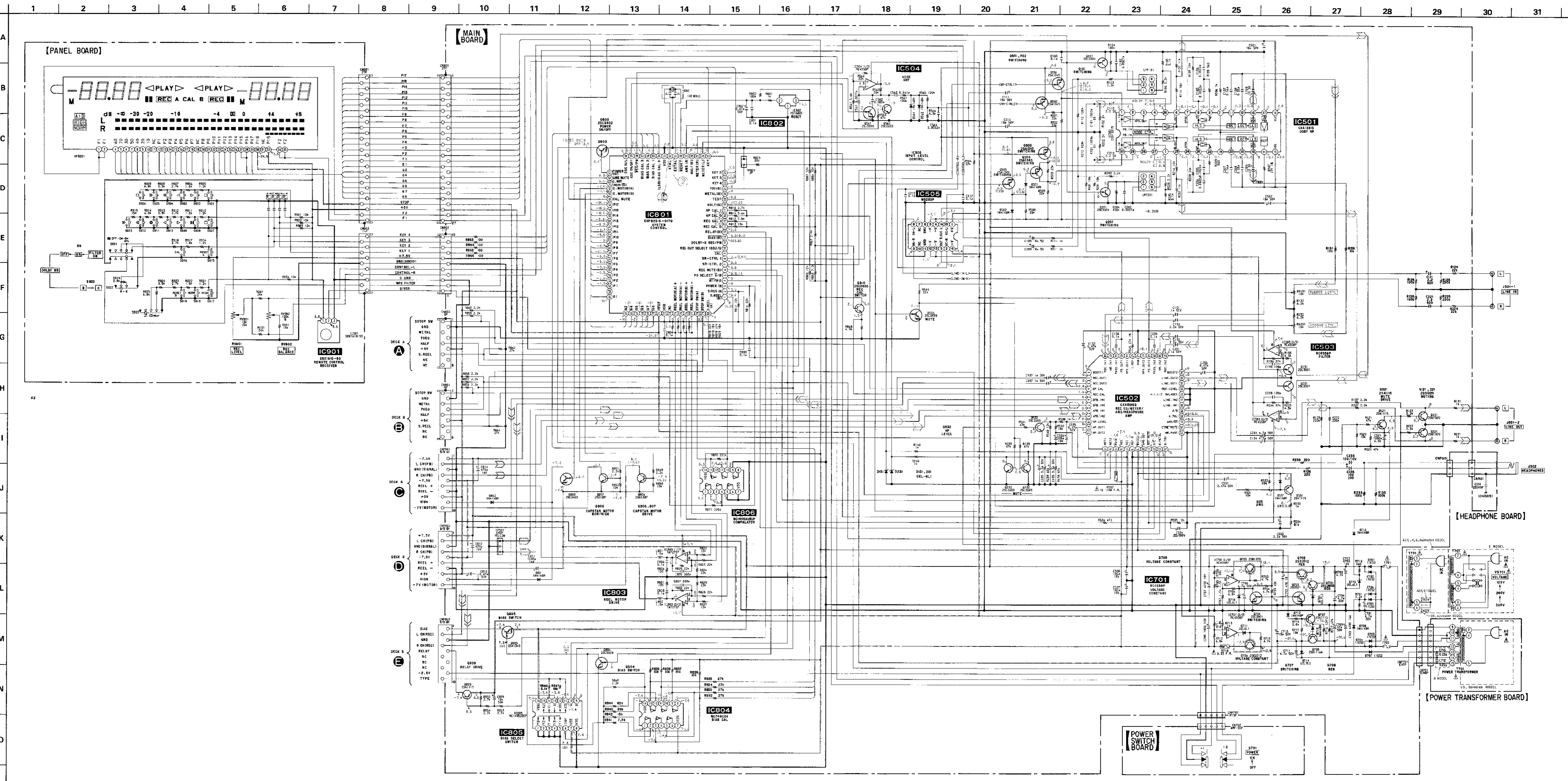

Note :

- All capacitors are in μF unless otherwise noted. pF: μF
- All resistors are in Ω and $k\Omega$ or less unless otherwise specified.
- Δ : internal component.
- \sim : fusible resistor.

Note :
The components identified by mark Δ or circled line with mark Δ are critical for safety. Replace only with part number specified.

Note :
Les composants identifiés par une marque Δ ou une ligne entourée par une marque Δ sont critiques pour la sécurité. Ne les remplacer que par une pièce portant le numéro spécifié.

— B — Line
— B — Line
— adjustment for repair.

Voltage and waveforms are de with respect to ground under no-signal conditions.
no mark : STOP
< > : REC
< > : CAL SW ON

Voltages are taken with a VOM (input impedance: 10M Ω).
Voltage variations may be noted due to normal production tolerances.

Waveforms are taken with a oscilloscope.
Voltage variations may be noted due to normal production tolerances.

Circled numbers refer to waveforms.

Signal path.
 < > : PB (DECK A)
 < > : REC (DECK B)
 < > : PB (DECK B)

G : Germany
AUS : Australian

5-5. SCHEMATIC DIAGRAM (AUDIO SECTION) Refer to page 23 for Note.

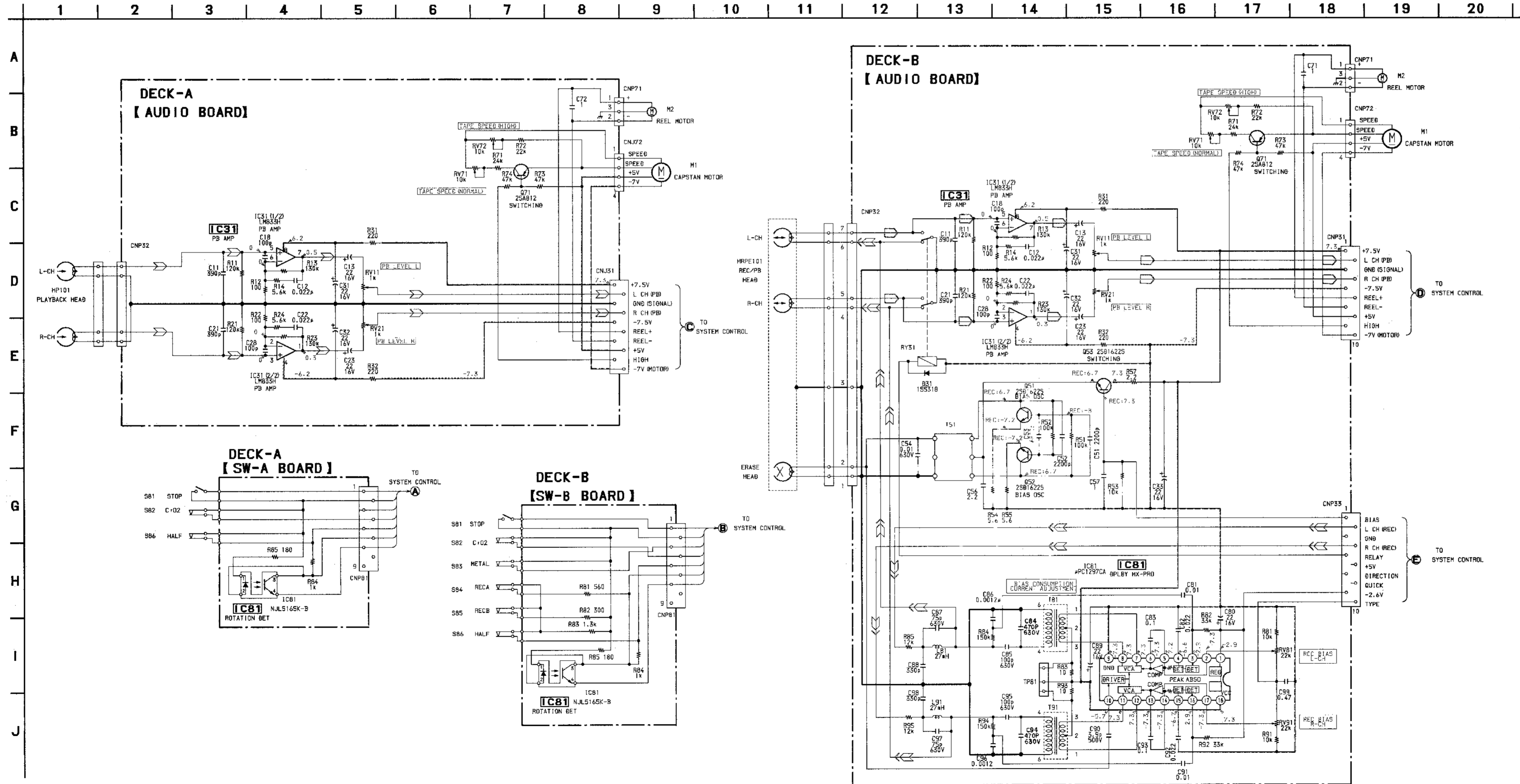

IC BLOCK DIAGRAMS

IC505 M5283P

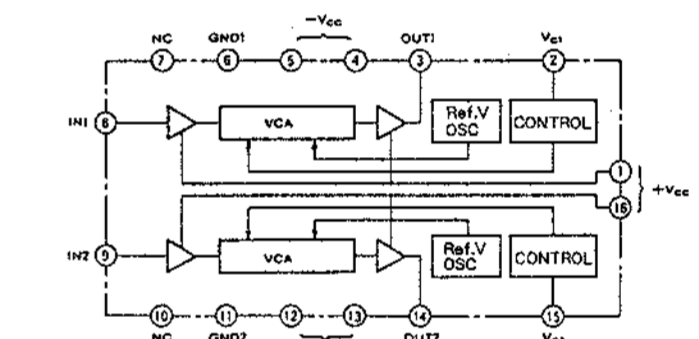

IC502 CXA1599Q

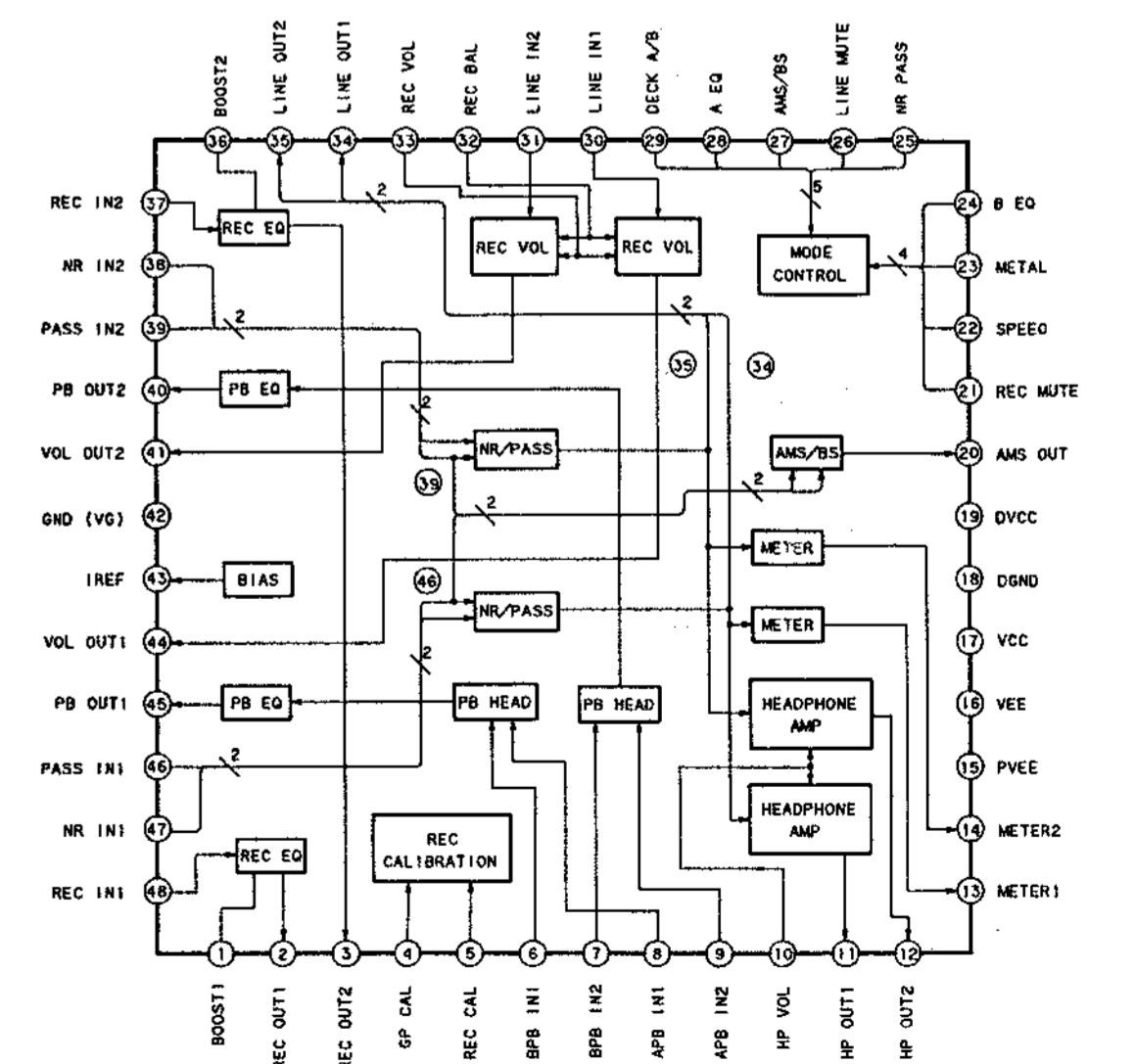

SECTION 6 EXPLODED VIEWS

NOTE:

- -XX, -X mean standardized parts, so they may have some difference from the original one.
- The construction parts of an assembled part are indicated with a collation number in the remark column.
- Color indication of Appearance Parts
Example :
KNOB, BALANCE (WHITE)...(RED)

↑ ↑
Parts color Cabinet's color

- Items marked " * " are not stocked since they are seldom required for routine service. Some delay should be anticipated when ordering these items.
- The mechanical parts with no reference number in the exploded views are not supplied.
- Hardware (# mark) list is given in the last of this parts list.

The components identified by mark ▲ or dotted line with mark ▲ are critical for safety. Replace only with part number specified.

Les composants identifiés par une marque ▲ sont critiques pour la sécurité. Ne les remplacer que par une pièce portant le numéro spécifié.

- G : Germany
- AUS : Australian

6-1. CHASSIS SECTION

▲ A : POWER TRANSFORMER BOARD

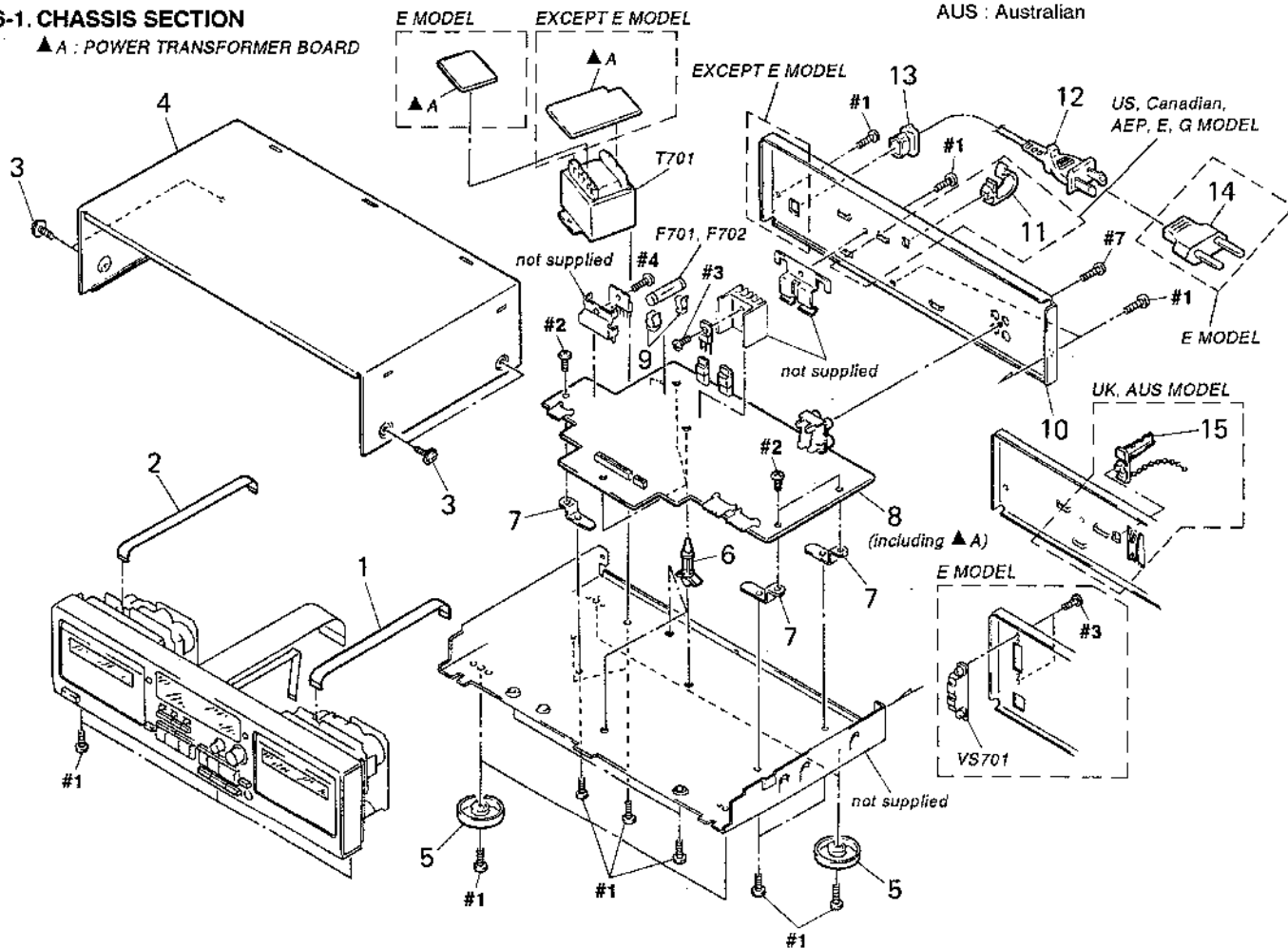

Ref. No.	Part No.	Description	Remark
1	1-690-906-11	WIRE (FLAT TYPE) (9 CORE)	
* 2	1-575-781-11	WIRE, FLAT TYPE (9 CORE)	
3	3-704-366-01	SCREW (CASE) (M3X8)	
4	3-332-578-61	CASE	
5	4-943-148-32	FOOT (F58175SW) (US, Canadian)	
5	4-943-148-42	FOOT (F58175SW) (AEP, UK, E, G, AUS)	
* 6	3-346-265-11	HOLDER, PC BOARD	
* 7	3-332-563-01	BRACKET (P)	
* 8	A-2006-976-A	MAIN BOARD, COMPLETE (US, Canadian, AEP, G)	
* 8	A-2007-043-A	MAIN BOARD, COMPLETE (UK, AUS)	
* 8	A-2007-044-A	MAIN BOARD, COMPLETE (E)	
* 9	1-533-293-11	FUSE HOLDER	
* 10	3-385-970-01	PANEL, BACK (US, Canadian)	
* 10	3-385-970-11	PANEL, BACK (AEP, G)	
* 10	3-385-970-21	PANEL, BACK (UK, AUS)	
* 10	3-385-970-31	PANEL, BACK (E)	
* 11	4-949-235-01	HOOK (US, Canadian, AEP, E, G)	

Ref. No.	Part No.	Description	Remark
▲12	1-551-188-XX	CORD, POWER (E)	
▲12	1-558-945-21	CORD, POWER (POLAR. SPT-1) (US, Canadian)	
▲12	1-575-651-21	CORD, POWER (AEP, G)	
▲12	1-696-586-11	CORD, POWER (UK)	
▲12	1-696-845-11	CORD, POWER (AUS)	
* 13	3-703-244-00	BUSHING (2104), CORD (AEP, UK, G, AUS)	
* 13	3-703-571-11	BUSHING (S) (4516), CORD (US, Canadian, E)	
▲14	1-569-007-11	ADAPTER, CONVERSION 2P (E)	
* 15	4-956-370-02	BAND, PLUG FIXED (UK, AUS)	
▲F701	1-532-285-00	FUSE, TIME LAG (1.250A) (AEP, UK, E, G, AUS)	
▲F701	1-576-103-11	FUSE (1.600A) (US, Canadian)	
▲F702	1-532-285-00	FUSE TIME LAG (1.250A) (AEP, UK, E, G, AUS)	
▲F702	1-576-103-11	FUSE (1.600A) (US, Canadian)	
▲T701	1-450-837-41	TRANSFORMER, POWER (US, Canadian)	
▲T701	1-450-838-41	TRANSFORMER, POWER (AEP, UK, G, AUS)	
▲T701	1-450-839-11	TRANSFORMER, POWER (E)	
▲VS701	1-692-155-11	SELECTOR, POWER VOLTAGE (VOLTAGE) (E)	

6-2. FRONT PANEL SECTION

■ B : POWER SWITCH BOARD

■ C : HEADPHONE BOARD

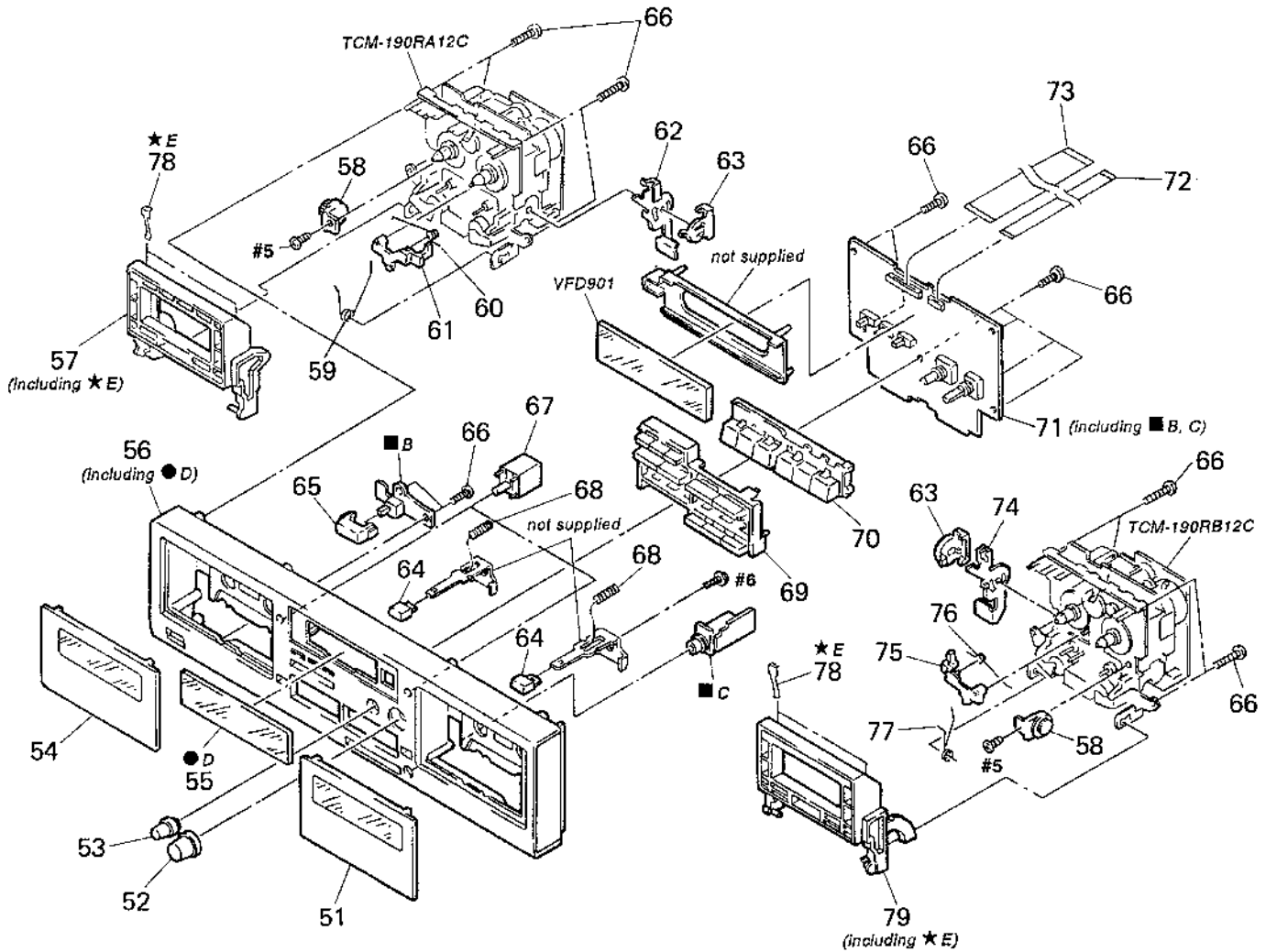

Ref. No.	Part No.	Description	Remark	Ref. No.	Part No.	Description	Remark
51	X-3366-113-1	LID (B) ASSY, CASSETTE		66	4-951-620-01	SCREW (2.6X8), +BVTP	
52	3-377-334-01	KNOB (RBC)		67	3-377-329-01	BUTTON (COUNTER)	
53	3-367-431-01	KNOB (BAL)		68	3-382-382-01	SPRING, COMPRESSION	
54	X-3366-112-1	LID (A) ASSY, CASSETTE		69	3-377-342-11	BUTTON (WR)	
55	3-377-335-01	WINDOW (M)		70	3-385-972-01	BUTTON (FR)	
56	X-3366-114-1	PANEL ASSY, FRONT (US, Canadian)		* 71	A-2006-977-A	PANEL BOARD, COMPLETE	
56	X-3366-115-1	PANEL ASSY, FRONT (AEP, UK, E, G, AUS)		72	1-690-911-11	WIRE (FLAT TYPE) (11 CORE)	
57	X-3340-195-1	HOLDER (R) ASSY, CASSETTE		73	1-575-628-11	WIRE, FLAT TYPE (27 CORE)	
58	3-354-963-01	DAMPER		* 74	3-354-953-01	LEVER (LOCK LEVER L)	
59	3-354-960-01	SPRING (LOADING R), TORSION		75	3-354-955-01	LEVER (EJ SAFTY LEVER L)	
60	3-354-962-01	SPRING (EJ SAFTY SPRING R)		76	3-354-961-01	SPRING (EJ SAFTY SPRING L)	
61	3-354-956-01	LEVER (EJ SAFTY LEVER R)		77	3-354-959-01	SPRING (LOADING L), TORSION	
* 62	3-354-954-01	LEVER (LOCK LEVER R)		78	3-308-823-11	SPRING	
63	3-354-957-01	JOINT (LOCK LEVER)		79	X-3340-194-1	HOLDER (L) ASSY, CASSETTE	
64	3-377-328-01	BUTTON (EJECT)		VFD901	1-517-162-11	INDICATOR TUBE, FLUORESCENT	
65	3-354-932-01	BUTTON (POWER)					

6-3. MECHANISM SECTION 1
(TCM-190RA12C : DECK A)
(TCM-190RB12C : DECK B)

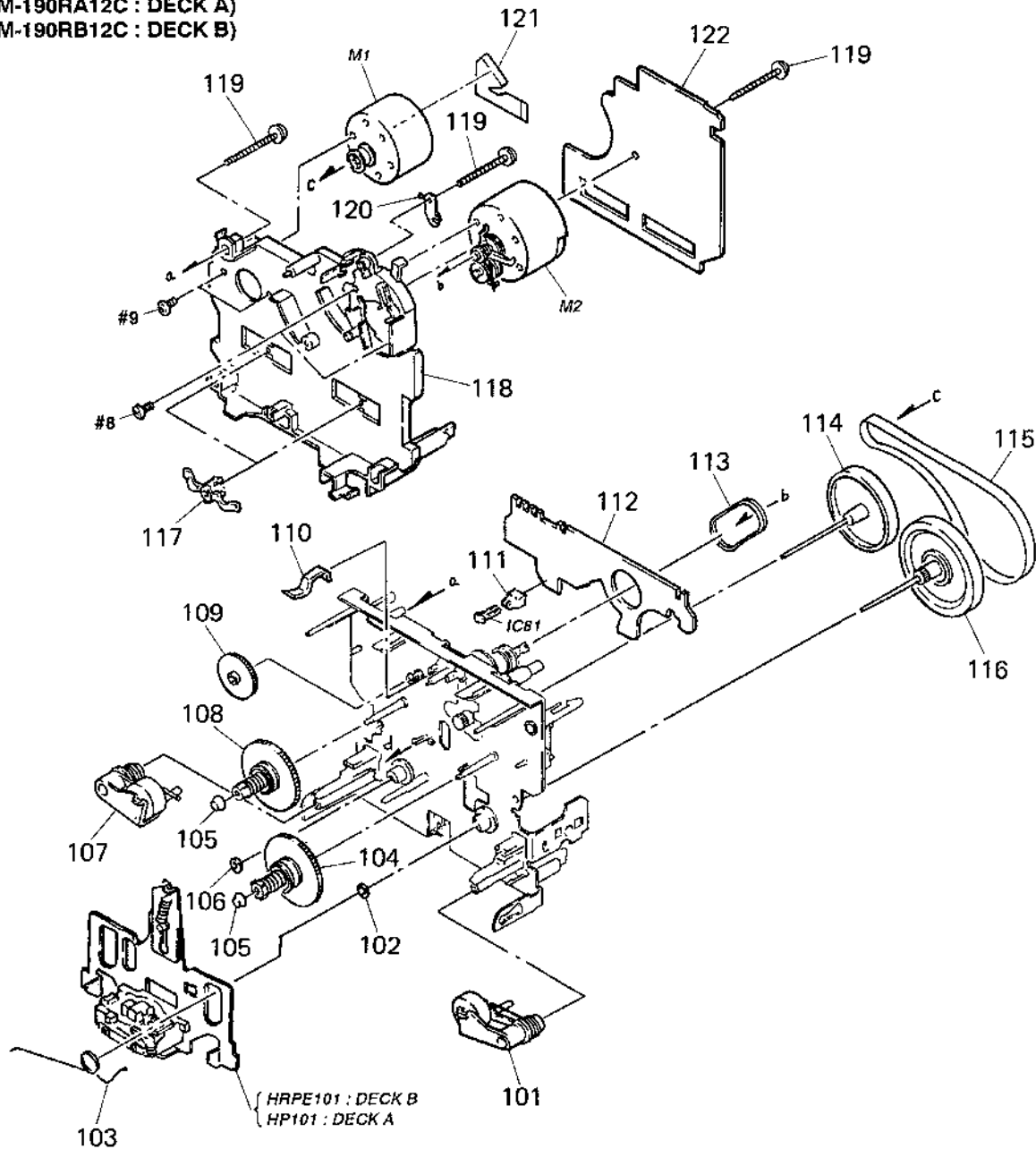

Ref. No.	Part No.	Description	Remark	Ref. No.	Part No.	Description	Remark
101	X-3359-408-1	LEVER (PINCH LEVER FWD) ASSY		115	3-359-417-01	BELT (FLAT), CAPSTAN	
102	3-356-713-01	WASHER		116	X-3359-406-1	FLYWHEEL (FWD) ASSY	
103	3-359-455-01	SPRING, TORSION		117	3-575-321-00	RETAINER, THRUST, CAPSTAN	
104	X-3359-404-1	TABLE ASSY, REEL		* 118	3-359-436-01	BASE (THRUST RETAINER), FITTING	
105	3-362-308-01	CAP (REEL)		119	3-359-414-01	SCREW (+PTPWH 2X23)	
106	3-356-714-01	WASHER		120	3-359-450-01	PLATE, GROUND	
107	X-3359-409-1	LEVER (PINCH LEVER REV) ASSY		121	1-638-983-11	PC BOARD, MOTOR FLEXIBLE	
108	X-3362-078-1	TABLE ASSY (B), REEL		* 122	A-2006-399-A	AUDIO BOARD (RA12A), COMPLETE (DECK-A)	
109	3-359-424-01	GEAR (REV GEAR)		* 122	A-2006-401-A	AUDIO BOARD (RB12A), COMPLETE (DECK-B)	
110	3-359-430-01	SPRING(CASSETTE RETAINER), LEAF		HP101	A-2003-837-F	BASE ASSY, HEAD (PLAYBACK)(DECK A)	
111	3-343-419-01	HOLDER (S SENSER A)		HRPE101	A-2003-838-A	BASE ASSY, HEAD (PLAYBACK/RECORD/ERASE) (DECK B)	
* 112	1-634-841-14	SW-A BOARD (DECK-A)		IC81	8-719-710-03	IC NJL516K-B	
* 112	1-634-841-14	SW-B BOARD (DECK-B)		M1	X-3359-417-1	MOTOR (CAPSTAN) ASSY	
113	3-359-466-01	BELT (FR), SQUARE		M2	X-3363-501-1	MOTOT ASSY, REEL	
114	X-3359-410-1	FLYWHEEL (REV) ASSY					

6-4. MECHANISM SECTION 2
 (TCM-190RA12C : DECK A)
 (TCM-190RB12C : DECK B)

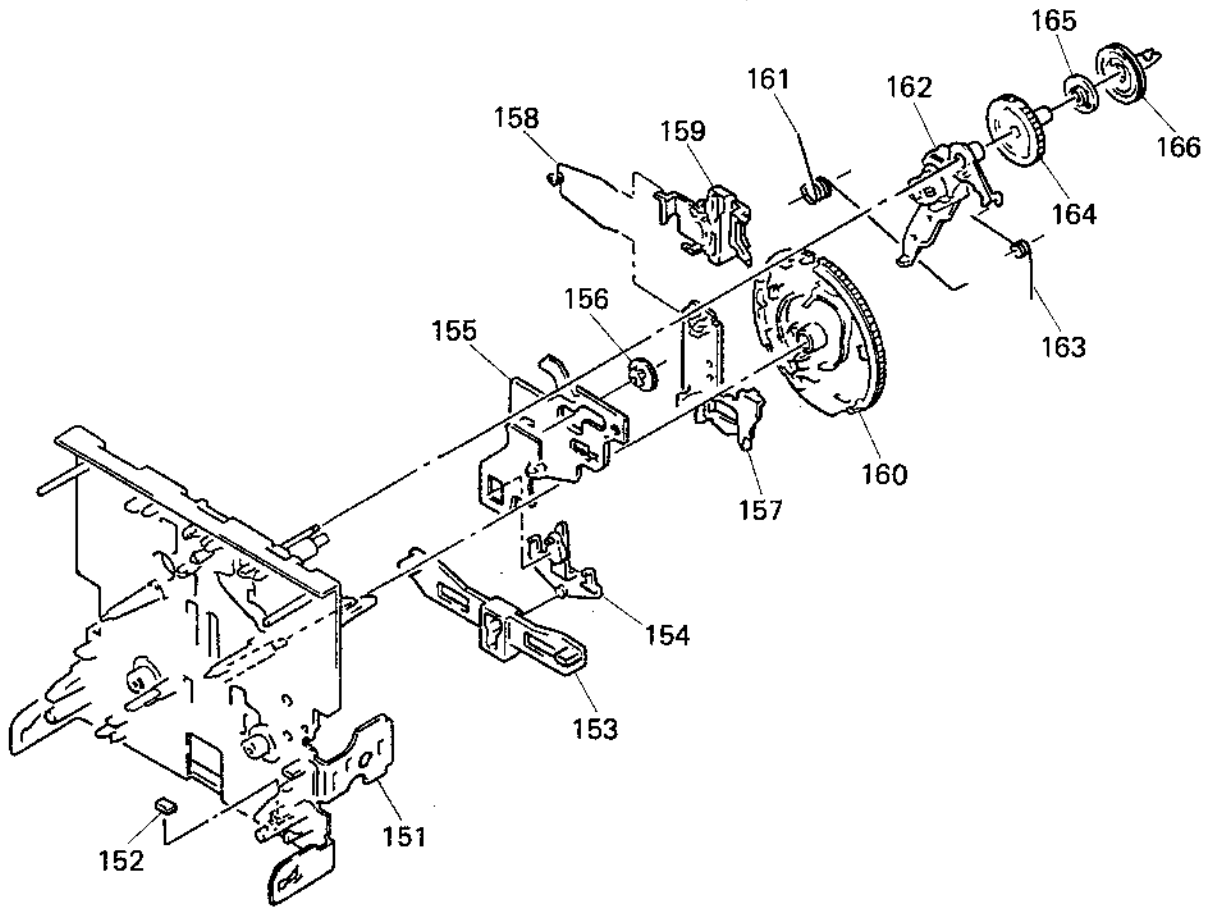

Ref.No.	Part No.	Description	Remark	Ref.No.	Part No.	Description	Remark
151	X-3359-415-1	CHASSIS ASSY, MECHANICAL		159	3-359-429-01	SLIDER (BRAKE PLATE)	
152	3-359-469-01	SPACER		160	3-359-420-01	GEAR (CAM GEAR)	
* 153	3-359-425-01	SLIDER (REVERSE SLIDER)		161	3-359-456-01	SPRING (TRIGGER SPRING), TORSION	
154	3-359-426-01	LEVER (REVERSE LEVER)		162	X-3359-405-1	LEVER (FR ARM) ASSY	
* 155	3-359-415-01	SLIDER (TRIGGER SLIDER)		163	3-359-453-01	SPRING (FR ARM), TORSION	
156	3-359-448-01	GEAR (TRIGGER)		164	3-359-419-01	GEAR (FR GEAR)	
* 157	3-359-427-01	SLIDER (LEVERSE SLIDER)		165	3-359-421-01	CLUTCH (REEL DISK)	
158	3-359-454-01	SPRING, TORSION		166	3-359-418-01	PULLEY (FR PULLEY)	

SECTION 7 ELECTRICAL PARTS LIST

MAIN

NOTE :

- Due to standardization, replacements in the parts list may be different from the parts specified in the diagrams or the components used on the set.
- -XX, -X mean standardized parts, so they may have some difference from the original one.
- RESISTORS
All resistors are in ohms
METAL : Metal-film resistor
METAL OXIDE : Metal oxide-film resistor
F : nonflammable

- Items marked " * " are not stocked since they are seldom required for routine service. Some delay should be anticipated when ordering these items.
- SEMICONDUCTORS
In each case, u : μ , for example :
uA..... : μ A....., uPA..... : μ PA.....
uPB..... : μ PB....., uPC..... : μ PC.....
uPD..... : μ PD.....
- CAPACITORS
uF : μ F
- COILS
uH : μ H

The components identified by mark Δ or dotted line with mark Δ are critical for safety. Replace only with part number specified.

Les composants identifiés par une marque Δ sont critiques pour la sécurité. Ne les remplacer que par une pièce portant le numéro spécifié.

When indicating parts by reference number, please include the board.

- G : Germany
- AUS : Australian

Ref. No.	Part No.	Description	Remark	Ref. No.	Part No.	Description	Remark
*	A-2006-976-A	MAIN BOARD, COMPLETE (US, Canadian, AEP, G)		C202	1-130-476-00	MYLAR	0.0027uF 5% 50V
		*****		C203	1-124-907-11	ELECT	10uF 20% 50V
*	A-2007-043-A	MAIN BOARD, COMPLETE (UK, AUS)		C205	1-130-475-00	MYLAR	0.0022uF 5% 50V
		*****		C206	1-130-475-00	MYLAR	0.0022uF 5% 50V
*	A-2007-044-A	MAIN BOARD, COMPLETE (E)		C207	1-136-174-00	FILM	0.56uF 5% 50V
		*****		C208	1-136-171-00	FILM	0.33uF 5% 50V
*	1-533-293-11	FUSE HOLDER		C209	1-124-907-11	ELECT	10uF 20% 50V
	1-690-880-81	LEAD (WITH CONNECTOR)		C210	1-124-925-11	ELECT	2.2uF 20% 100V
	7-685-646-79	SCREW +BVTP 3X8 TYPE2 IT-3		C211	1-124-907-11	ELECT	10uF 20% 50V
	7-685-871-01	SCREW +BVTT 3X6 (S)		C212	1-164-159-11	CERAMIC	0.1uF 50V
		< CAPACITOR >		C221	1-124-925-11	ELECT	2.2uF 20% 100V
C101	1-162-294-31	CERAMIC	0.001uF 10% 50V	C231	1-124-903-11	ELECT	1uF 20% 50V
C102	1-130-476-00	MYLAR	0.0027uF 5% 50V	C232	1-124-925-11	ELECT	2.2uF 20% 100V
C103	1-124-907-11	ELECT	10uF 20% 50V	C233	1-124-902-00	ELECT	0.47uF 20% 50V
C105	1-130-475-00	MYLAR	0.0022uF 5% 50V	C234	1-124-927-11	ELECT	4.7uF 20% 100V
C106	1-130-475-00	MYLAR	0.0022uF 5% 50V	C235	1-123-382-00	ELECT	3.3uF 20% 100V
C107	1-136-174-00	FILM	0.56uF 5% 50V	C236	1-124-443-00	ELECT	100uF 20% 10V
C108	1-136-171-00	FILM	0.33uF 5% 50V	C237	1-124-903-11	ELECT	1uF 20% 50V
C109	1-124-907-11	ELECT	10uF 20% 50V	C238	1-164-159-11	CERAMIC	0.1uF 50V
C110	1-124-925-11	ELECT	2.2uF 20% 100V	C239	1-162-283-31	CERAMIC	120PF 10% 50V
C111	1-124-907-11	ELECT	10uF 20% 50V	C501	1-124-907-11	ELECT	10uF 20% 50V
C112	1-164-159-11	CERAMIC	0.1uF 50V	C502	1-124-907-11	ELECT	10uF 20% 50V
C121	1-124-925-11	ELECT	2.2uF 20% 100V	C503	1-164-159-11	CERAMIC	0.1uF 50V
C131	1-124-903-11	ELECT	1uF 20% 50V	C521	1-124-471-00	ELECT	1000uF 20% 6.3V
C132	1-124-925-11	ELECT	2.2uF 20% 100V	C531	1-124-902-00	ELECT	0.47uF 20% 50V
C133	1-124-902-00	ELECT	0.47uF 20% 50V	C533	1-124-925-11	ELECT	2.2uF 20% 100V
C134	1-124-927-11	ELECT	4.7uF 20% 100V	C534	1-124-916-11	ELECT	22uF 20% 63V
C135	1-123-382-00	ELECT	3.3uF 20% 100V	C535	1-124-902-00	ELECT	0.47uF 20% 50V
C136	1-124-443-00	ELECT	100uF 20% 10V	C536	1-124-443-00	ELECT	100uF 20% 10V
C137	1-124-903-11	ELECT	1uF 20% 50V	C537	1-124-443-00	ELECT	100uF 20% 10V
C138	1-164-159-11	CERAMIC	0.1uF 50V	C538	1-124-443-00	ELECT	100uF 20% 10V
C139	1-162-283-31	CERAMIC	120PF 10% 50V	C561	1-130-476-00	MYLAR	0.0027uF 5% 50V
C201	1-162-294-31	CERAMIC	0.001uF 10% 50V	C562	1-136-164-00	FILM	0.082uF 5% 50V
				C563	1-136-161-00	FILM	0.047uF 5% 50V

MAIN

Ref. No.	Part No.	Description	Remark
C564	1-130-475-00	MYLAR	0.0022uF 5% 50V
C701	1-124-927-11	ELECT	4.7uF 20% 100V
C702	1-124-898-11	ELECT	4700uF 20% 16V
C703	1-124-898-11	ELECT	4700uF 20% 16V
C704	1-124-927-11	ELECT	4.7uF 20% 100V
C705	1-124-472-11	ELECT	470uF 20% 10V
C706	1-124-927-11	ELECT	4.7uF 20% 100V
C707	1-124-762-00	ELECT	4700uF 20% 10V
C708	1-124-473-11	ELECT	1000uF 20% 10V
C709	1-124-910-11	ELECT	47uF 20% 50V
C710	1-124-907-11	ELECT	10uF 20% 50V
C711	1-124-927-11	ELECT	4.7uF 20% 100V
C712	1-136-169-00	FILM	0.22uF 5% 50V
C713	1-136-169-00	FILM	(G) <POWER TRANSFORMER BOARD> 0.22uF 5% 50V (G) <POWER TRANSFORMER BOARD>
C801	1-164-159-11	CERAMIC	0.1uF 50V
C802	1-124-902-00	ELECT	0.47uF 20% 50V
C803	1-164-159-11	CERAMIC	0.1uF 50V
C804	1-164-159-11	CERAMIC	0.1uF 50V
C805	1-162-288-31	CERAMIC	330PF 10% 50V
C806	1-164-159-11	CERAMIC	0.1uF 50V
C807	1-162-288-31	CERAMIC	330PF 10% 50V
C808	1-164-159-11	CERAMIC	0.1uF 50V
C809	1-124-907-11	ELECT	10uF 20% 50V
C810	1-124-902-00	ELECT	0.47uF 20% 50V
C811	1-124-360-00	ELECT	1000uF 20% 16V
C812	1-126-103-11	ELECT	470uF 20% 16V
C814	1-126-103-11	ELECT	470uF 20% 16V
< CONNECTOR >			
* CN801	1-568-842-11	SOCKET, CONNECTOR 27P	
* CN802	1-568-830-11	SOCKET, CONNECTOR 11P	
* CN803	1-568-828-11	SOCKET, CONNECTOR 9P	
* CN804	1-568-828-11	SOCKET, CONNECTOR 9P	
< CONNECTOR >			
CNP501	1-506-468-11	PIN, CONNECTOR 3P	
* CNP701	1-564-510-11	PLUG, CONNECTOR 7P	
* CNP702	1-568-954-11	PIN, CONNECTOR 5P	
* CNP703	1-580-230-31	PIN, CONNECTOR (PC BOARD) 2P	(US, Canadian, AEP, UK, G, AUS)
* CNP801	1-691-916-11	CONNECTOR, BOARD TO BOARD	
* CNP802	1-691-916-11	CONNECTOR, BOARD TO BOARD	
* CNP803	1-691-916-11	CONNECTOR, BOARD TO BOARD	
< DIODE >			
D131	8-719-933-33	DIODE	HZS6AIL
D231	8-719-933-33	DIODE	HZS6AIL

Ref. No.	Part No.	Description	Remark
D501	8-719-987-63	DIODE	1N4148M
D502	8-719-987-63	DIODE	1N4148M
D531	8-719-987-63	DIODE	1N4148M
D561	8-719-987-63	DIODE	1N4148M
D562	8-719-987-63	DIODE	1N4148M
D701	8-719-200-82	DIODE	11ES2
D702	8-719-200-82	DIODE	11ES2
D703	8-719-200-82	DIODE	11ES2
D704	8-719-200-82	DIODE	11ES2
D705	8-719-200-82	DIODE	11ES2
D706	8-719-200-82	DIODE	11ES2
D707	8-719-200-82	DIODE	11ES2
D708	8-719-987-63	DIODE	1N4148M
D709	8-719-000-78	DIODE	UZL-7L2
D710	8-719-933-33	DIODE	HZS6AIL
D711	8-719-933-33	DIODE	HZS6AIL
D712	8-719-987-63	DIODE	1N4148M
D713	8-719-987-63	DIODE	1N4148M
D714	8-719-000-78	DIODE	UZL-7L2
D715	8-719-933-33	DIODE	HZS6AIL
D716	8-719-987-63	DIODE	1N4148M
D801	8-719-987-63	DIODE	1N4148M
D802	8-719-987-63	DIODE	1N4148M
< IC >			
IC501	8-752-059-55	IC	CXA1331S
IC502	8-752-058-57	IC	CXA1599Q
IC503	8-759-145-58	IC	uPC4558C
IC504	8-759-145-58	IC	uPC4558C
IC505	8-759-635-26	IC	M5283P
IC701	8-759-145-58	IC	uPC4558C
IC801	8-752-843-99	IC	CXP82316-017Q
IC802	8-759-165-82	IC	PST600E-T
IC803	8-759-207-05	IC	TA7272P
IC804	8-759-916-14	IC	SN74HC04N
IC805	8-759-000-48	IC	MC14052BCP
IC806	8-759-240-69	IC	TC4069UBP
< JACK >			
J501	1-565-258-11	JACK, PIN 4P (LINE IN/OUT)	
< COIL >			
* L801	1-420-872-00	COIL, AIR CORE	
* L802	1-420-872-00	COIL, AIR CORE	
< FILTER >			
LPF101	1-231-388-00	FILTER, LOW PASS	
LPF201	1-231-388-00	FILTER, LOW PASS	

Ref. No.	Part No.	Description	Remark	Ref. No.	Part No.	Description	Remark
< TRANSISTOR >							
Q101	8-729-900-74	TRANSISTOR DTC143TS		R114	1-249-429-11	CARBON 10K 5% 1/4W	
Q121	8-729-922-37	TRANSISTOR 2SD2144S-UVW		R121	1-249-417-11	CARBON 1K 5% 1/4W	
Q131	8-729-900-74	TRANSISTOR DTC143TS		R122	1-247-887-00	CARBON 220K 5% 1/4W	
Q132	8-729-620-05	TRANSISTOR 2SC2603-EF		R123	1-249-421-11	CARBON 2.2K 5% 1/4W	
Q201	8-729-900-74	TRANSISTOR DTC143TS		R124	1-249-433-11	CARBON 22K 5% 1/4W	
Q221	8-729-922-37	TRANSISTOR 2SD2144S-UVW		R125	1-247-887-00	CARBON 220K 5% 1/4W	
Q231	8-729-900-74	TRANSISTOR DTC143TS		R126	1-249-441-11	CARBON 100K 5% 1/4W	
Q232	8-729-620-05	TRANSISTOR 2SC2603-EF		R131	1-249-429-11	CARBON 10K 5% 1/4W	
Q501	8-729-900-65	TRANSISTOR DTA144ES		R132	1-247-850-11	CARBON 6.2K 5% 1/4W	
Q502	8-729-900-65	TRANSISTOR DTA144ES		R133	1-247-846-11	CARBON 4.3K 5% 1/4W	
Q503	8-729-900-65	TRANSISTOR DTA144ES		R134	1-249-434-11	CARBON 27K 5% 1/4W	
Q504	8-729-900-65	TRANSISTOR DTA144ES		R135	1-249-441-11	CARBON 100K 5% 1/4W	
Q505	8-729-900-65	TRANSISTOR DTA144ES		R136	1-249-409-11	CARBON 220 5% 1/4W	
Q521	8-729-119-76	TRANSISTOR 2SA1175-HFE		R137	1-249-421-11	CARBON 2.2K 5% 1/4W	
Q531	8-729-119-76	TRANSISTOR 2SA1175-HFE		R138	1-249-439-11	CARBON 68K 5% 1/4W	
Q532	8-729-620-05	TRANSISTOR 2SC2603-EF		R139	1-249-437-11	CARBON 47K 5% 1/4W	
Q535	8-729-900-89	TRANSISTOR DTC144ES		R140	1-249-417-11	CARBON 1K 5% 1/4W	
Q561	8-729-900-89	TRANSISTOR DTC144ES		R157	1-247-856-00	CARBON 11K 5% 1/4W	
Q562	8-729-620-05	TRANSISTOR 2SC2603-EF		R201	1-249-432-11	CARBON 18K 5% 1/4W	
Q701	8-729-620-05	TRANSISTOR 2SC2603-EF		R202	1-247-838-00	CARBON 2K 5% 1/4W	
Q702	8-729-209-15	TRANSISTOR 2SD2012		R203	1-249-421-11	CARBON 2.2K 5% 1/4W	
Q703	8-729-900-74	TRANSISTOR DTC143TS		R204	1-249-441-11	CARBON 100K 5% 1/4W	
Q704	8-729-900-74	TRANSISTOR DTC143TS		R205	1-247-848-11	CARBON 5.1K 5% 1/4W	
Q705	8-729-141-83	TRANSISTOR 2SB1094-LK		R206	1-249-421-11	CARBON 2.2K 5% 1/4W	
Q706	8-729-209-15	TRANSISTOR 2SD2012		R208	1-247-864-11	CARBON 24K 5% 1/4W	
Q707	8-729-119-76	TRANSISTOR 2SA1175-HFE		R209	1-249-414-11	CARBON 560 5% 1/4W	
Q708	8-729-140-04	TRANSISTOR 2SB1116A-L		R211	1-249-417-11	CARBON 1K 5% 1/4W	
Q803	8-729-900-80	TRANSISTOR DTC114ES		R212	1-249-441-11	CARBON 100K 5% 1/4W	
Q804	8-729-900-89	TRANSISTOR DTC114ES		R214	1-249-429-11	CARBON 10K 5% 1/4W	
Q805	8-729-900-65	TRANSISTOR DTA144ES		R221	1-249-417-11	CARBON 1K 5% 1/4W	
Q806	8-729-801-93	TRANSISTOR 2SD1387-3		R222	1-247-887-00	CARBON 220K 5% 1/4W	
Q807	8-729-801-93	TRANSISTOR 2SD1387-3		R223	1-249-421-11	CARBON 2.2K 5% 1/4W	
Q808	8-729-900-80	TRANSISTOR DTC114ES		R224	1-249-433-11	CARBON 22K 5% 1/4W	
Q809	8-729-119-76	TRANSISTOR 2SA1175-HFE		R225	1-247-887-00	CARBON 220K 5% 1/4W	
Q810	8-729-620-05	TRANSISTOR 2SC2603-EF		R226	1-249-441-11	CARBON 100K 5% 1/4W	
< RESISTOR >							
R101	1-249-432-11	CARBON 18K 5% 1/4W		R231	1-249-429-11	CARBON 10K 5% 1/4W	
R102	1-247-838-00	CARBON 2K 5% 1/4W		R232	1-247-850-11	CARBON 6.2K 5% 1/4W	
R103	1-249-421-11	CARBON 2.2K 5% 1/4W		R233	1-247-846-11	CARBON 4.3K 5% 1/4W	
R104	1-249-441-11	CARBON 100K 5% 1/4W		R234	1-249-434-11	CARBON 27K 5% 1/4W	
R105	1-247-848-11	CARBON 5.1K 5% 1/4W		R235	1-249-441-11	CARBON 100K 5% 1/4W	
R106	1-249-421-11	CARBON 2.2K 5% 1/4W		R236	1-249-409-11	CARBON 220 5% 1/4W	
R108	1-247-864-11	CARBON 24K 5% 1/4W		R237	1-249-421-11	CARBON 2.2K 5% 1/4W	
R109	1-249-414-11	CARBON 560 5% 1/4W		R238	1-249-439-11	CARBON 68K 5% 1/4W	
R111	1-249-417-11	CARBON 1K 5% 1/4W		R239	1-249-437-11	CARBON 47K 5% 1/4W	
R112	1-249-441-11	CARBON 100K 5% 1/4W		R240	1-249-417-11	CARBON 1K 5% 1/4W	
				R257	1-247-856-00	CARBON 11K 5% 1/4W	
				R501	1-249-433-11	CARBON 22K 5% 1/4W	
				R502	1-249-435-11	CARBON 33K 5% 1/4W	

MAIN

Ref. No.	Part No.	Description	Remark			Ref. No.	Part No.	Description	Remark		
R503	1-249-433-11	CARBON	22K	5%	1/4W	R802	1-249-441-11	CARBON	100K	5%	1/4W
R504	1-249-433-11	CARBON	22K	5%	1/4W	R805	1-249-435-11	CARBON	33K	5%	1/4W
R505	1-249-435-11	CARBON	33K	5%	1/4W	R806	1-249-429-11	CARBON	10K	5%	1/4W
R506	1-249-417-11	CARBON	1K	5%	1/4W	R807	1-249-430-11	CARBON	12K	5%	1/4W
R507	1-215-455-00	METAL	27K	1%	1/6W	R808	1-247-852-11	CARBON	7.5K	5%	1/4W
R508	1-249-435-11	CARBON	33K	5%	1/4W	R809	1-249-430-11	CARBON	12K	5%	1/4W
R521	1-249-437-11	CARBON	47K	5%	1/4W	R810	1-249-422-11	CARBON	2.7K	5%	1/4W
R522	1-249-429-11	CARBON	10K	5%	1/4W	R811	1-249-426-11	CARBON	5.6K	5%	1/4W
R523	1-249-437-11	CARBON	47K	5%	1/4W	R812	1-247-852-11	CARBON	7.5K	5%	1/4W
R531	1-249-429-11	CARBON	10K	5%	1/4W	R813	1-247-858-11	CARBON	13K	5%	1/4W
R532	1-249-429-11	CARBON	10K	5%	1/4W	R816	1-249-433-11	CARBON	22K	5%	1/4W
R533	1-249-417-11	CARBON	1K	5%	1/4W	R817	1-249-433-11	CARBON	22K	5%	1/4W
R534	1-247-872-11	CARBON	51K	5%	1/4W	R818	1-249-433-11	CARBON	22K	5%	1/4W
R535	1-249-429-11	CARBON	10K	5%	1/4W	R819	1-249-429-11	CARBON	10K	5%	1/4W
R536	1-249-413-11	CARBON	470	5%	1/4W	R820	1-249-433-11	CARBON	22K	5%	1/4W
△R537	1-212-863-00	FUSIBLE	18	5%	1/4W F	R821	1-249-429-11	CARBON	10K	5%	1/4W
R538	1-249-417-11	CARBON	1K	5%	1/4W	R822	1-249-430-11	CARBON	12K	5%	1/4W
R539	1-249-432-11	CARBON	18K	5%	1/4W	R823	1-249-433-11	CARBON	22K	5%	1/4W
R540	1-249-430-11	CARBON	12K	5%	1/4W	R824	1-249-433-11	CARBON	22K	5%	1/4W
R541	1-249-437-11	CARBON	47K	5%	1/4W	R825	1-249-433-11	CARBON	22K	5%	1/4W
R544	1-249-433-11	CARBON	22K	5%	1/4W	R826	1-249-405-11	CARBON	100	5%	1/4W
R545	1-215-455-00	METAL	27K	1%	1/6W	R827	1-249-430-11	CARBON	12K	5%	1/4W
R561	1-249-426-11	CARBON	5.6K	5%	1/4W	R828	1-249-433-11	CARBON	22K	5%	1/4W
R562	1-249-433-11	CARBON	22K	5%	1/4W	R829	1-249-433-11	CARBON	22K	5%	1/4W
R563	1-249-436-11	CARBON	39K	5%	1/4W	R830	1-249-433-11	CARBON	22K	5%	1/4W
R564	1-249-437-11	CARBON	47K	5%	1/4W	R831	1-249-405-11	CARBON	100	5%	1/4W
R565	1-249-441-11	CARBON	100K	5%	1/4W	R832	1-249-434-11	CARBON	27K	5%	1/4W
R566	1-247-846-11	CARBON	4.3K	5%	1/4W	R833	1-249-434-11	CARBON	27K	5%	1/4W
R567	1-249-441-11	CARBON	100K	5%	1/4W	R834	1-249-434-11	CARBON	27K	5%	1/4W
R701	1-249-421-11	CARBON	2.2K	5%	1/4W	R835	1-249-434-11	CARBON	27K	5%	1/4W
R702	1-249-425-11	CARBON	4.7K	5%	1/4W	R836	1-249-429-11	CARBON	10K	5%	1/4W
R703	1-249-429-11	CARBON	10K	5%	1/4W	R837	1-249-429-11	CARBON	10K	5%	1/4W
R704	1-249-425-11	CARBON	4.7K	5%	1/4W	R838	1-249-429-11	CARBON	10K	5%	1/4W
R705	1-249-425-11	CARBON	4.7K	5%	1/4W	R839	1-249-429-11	CARBON	10K	5%	1/4W
R706	1-249-427-11	CARBON	6.8K	5%	1/4W	R840	1-249-421-11	CARBON	2.2K	5%	1/4W
R707	1-249-419-11	CARBON	1.5K	5%	1/4W	R841	1-247-874-11	CARBON	62K	5%	1/4W
R708	1-249-429-11	CARBON	10K	5%	1/4W	R842	1-247-866-11	CARBON	30K	5%	1/4W
R709	1-249-419-11	CARBON	1.5K	5%	1/4W	R843	1-249-431-11	CARBON	15K	5%	1/4W
R710	1-249-425-11	CARBON	4.7K	5%	1/4W	R844	1-247-852-11	CARBON	7.5K	5%	1/4W
R711	1-249-427-11	CARBON	6.8K	5%	1/4W	R847	1-249-432-11	CARBON	18K	5%	1/4W
R712	1-249-427-11	CARBON	6.8K	5%	1/4W	R848	1-247-848-11	CARBON	5.1K	5%	1/4W
R713	1-249-417-11	CARBON	1K	5%	1/4W	R849	1-249-421-11	CARBON	2.2K	5%	1/4W
R714	1-247-842-11	CARBON	3K	5%	1/4W	R850	1-249-429-11	CARBON	10K	5%	1/4W
R715	1-249-429-11	CARBON	10K	5%	1/4W	R851	1-249-421-11	CARBON	2.2K	5%	1/4W
R716	1-249-430-11	CARBON	12K	5%	1/4W	R852	1-249-429-11	CARBON	10K	5%	1/4W
R717	1-249-437-11	CARBON	47K	5%	1/4W	R853	1-249-422-11	CARBON	2.7K	5%	1/4W
△R718	1-219-137-11	FUSIBLE	0.33	10%	1/4W F	R854	1-249-422-11	CARBON	2.7K	5%	1/4W
R719	1-249-414-11	CARBON	560	5%	1/4W	R855	1-249-422-11	CARBON	2.7K	5%	1/4W
R801	1-249-417-11	CARBON	1K	5%	1/4W	R856	1-249-421-11	CARBON	2.2K	5%	1/4W

The components identified by mark Δ or dotted line with mark Δ are critical for safety. Replace only with part number specified.

Les composants identifiés par une marque Δ sont critiques pour la sécurité. Ne les remplacer que par une pièce portant le numéro spécifié.

MAIN **SW-A** **AUDIO**

Ref.No.	Part No.	Description	Remark		
R857	1-249-421-11	CARBON	2.2K	5%	1/4W
R858	1-249-421-11	CARBON	2.2K	5%	1/4W
R859	1-249-421-11	CARBON	2.2K	5%	1/4W
R860	1-249-421-11	CARBON	2.2K	5%	1/4W
R861	1-249-434-11	CARBON	27K	5%	1/4W
R862	1-249-434-11	CARBON	27K	5%	1/4W
R863	1-249-405-11	CARBON	100	5%	1/4W
R864	1-249-405-11	CARBON	100	5%	1/4W
R865	1-249-405-11	CARBON	100	5%	1/4W
R866	1-249-405-11	CARBON	100	5%	1/4W
R867	1-247-840-00	CARBON	2.4K	5%	1/4W
R868	1-249-425-11	CARBON	4.7K	5%	1/4W
R870	1-247-887-00	CARBON	220K	5%	1/4W
R871	1-247-887-00	CARBON	220K	5%	1/4W
< VARIABLE RESISTOR >					
RV131	1-241-630-11	RES, ADJ, CARBON 10K (REC LEVEL)			
RV231	1-241-630-11	RES, ADJ, CARBON 10K (REC LEVEL)			
< TEST PIN >					
* TP501	1-564-506-11	PLUG, CONNECTOR 3P			
* TP801	1-564-505-41	PLUG, CONNECTOR 2P			
< CRYSTAL >					
X801	1-577-377-11	VIBRATOR, CERAMIC (10MHz)			

* 1-634-841-14	SW-A BOARD (DECK A)				

3-343-419-01	HOLDER (S SENSER A)				
< CONNECTOR >					
* CNP81	1-568-852-11	SOCKET, CONNECTOR 9P			
< IC >					
IC81	8-719-710-03	IC NJL5165K-B			
< RESISTOR >					
R84	1-249-417-11	CARBON	1K	5%	1/4W
R85	1-249-408-11	CARBON	180	5%	1/4W
< SWITCH >					
S81	1-571-958-11	SWITCH, PUSH (1 KEY) (STOP SW)			
S82	1-571-281-21	SWITCH, LEAF (CrO2)			
S86	1-571-281-21	SWITCH, LEAF (HALF)			

Ref.No.	Part No.	Description	Remark		
*	A-2006-399-A	AUDIO BOARD (RA12A), COMPLETE (DECK A)			

< CAPACITOR >					
C11	1-163-131-00	CERAMIC CHIP	390PF	5%	50V
C12	1-136-157-00	FILM	0.022uF	5%	50V
C13	1-124-234-00	ELECT	22uF	20%	16V
C18	1-163-117-00	CERAMIC CHIP	100PF	5%	50V
C21	1-163-131-00	CERAMIC CHIP	390PF	5%	50V
C22	1-136-157-00	FILM	0.022uF	5%	50V
C23	1-124-234-00	ELECT	22uF	20%	16V
C28	1-163-117-00	CERAMIC CHIP	100PF	5%	50V
C31	1-124-234-00	ELECT	22uF	20%	16V
C32	1-124-234-00	ELECT	22uF	20%	16V
C72	1-124-499-11	ELECT, NONPOLAR 1uF		20%	50V
< JACK >					
* CNJ31	1-580-782-11	CONNECTOR, BOARD TO BOARD			
* CNJ72	1-580-411-11	SOCKET, CONNECTOR 4P			
< CONNECTOR >					
* CNP32	1-580-772-11	PIN, CONNECTOR (PC BOARD) 4P			
* CNP71	1-564-719-11	PIN, CONNECTOR (SMALL TYPE) 3P			
< IC >					
IC31	8-759-106-02	IC uPC4570G2			
< JUMPER RESISTOR >					
JW1	1-216-295-00	METAL CHIP	0	5%	1/10W
JW51	1-216-296-00	METAL CHIP	0	5%	1/8W
JW52	1-216-296-00	METAL CHIP	0	5%	1/8W
JW53	1-216-296-00	METAL CHIP	0	5%	1/8W
JW54	1-216-296-00	METAL CHIP	0	5%	1/8W
< TRANSISTOR >					
Q71	8-729-602-36	TRANSISTOR 2SA1602			
< RESISTOR >					
R11	1-216-099-00	METAL CHIP	120K	5%	1/10W
R12	1-216-025-00	METAL CHIP	100	5%	1/10W
R13	1-216-100-00	METAL GLAZE	130K	5%	1/10W
R14	1-216-067-00	METAL CHIP	5.6K	5%	1/10W
R21	1-216-099-00	METAL CHIP	120K	5%	1/10W
R22	1-216-025-00	METAL CHIP	100	5%	1/10W
R23	1-216-100-00	METAL GLAZE	130K	5%	1/10W
R24	1-216-067-00	METAL CHIP	5.6K	5%	1/10W
R31	1-216-033-00	METAL CHIP	220	5%	1/10W
R32	1-216-033-00	METAL CHIP	220	5%	1/10W

AUDIO

SW-A

Ref. No.	Part No.	Description	Remark
R71	1-216-082-00	METAL GLAZE 24K 5%	1/10W
R72	1-216-081-00	METAL CHIP 22K 5%	1/10W
R73	1-216-089-00	METAL CHIP 47K 5%	1/10W
R74	1-216-089-00	METAL CHIP 47K 5%	1/10W
< VARIABLE RESISTOR >			
RV11	1-241-627-11	RES, ADJ, CARBON 1K (PB LEVEL L)	
RV21	1-241-627-11	RES, ADJ, CARBON 1K (PB LEVEL R)	
RV71	1-241-630-11	RES, ADJ, CARBON 10K (NORMAL SPEED)	
RV72	1-241-630-11	RES, ADJ, CARBON 10K (HIGH SPEED)	

*	1-634-841-14	SW-B BOARD (DECK B)	*****
	3-343-419-01	HOLDER (S SENSER A)	
< CONNECTOR >			
* CNP81	1-568-852-11	SOCKET, CONNECTOR 9P	
< IC >			
IC81	8-719-710-03	IC NJL5165K-B	
< RESISTOR >			
R81	1-249-414-11	CARBON 560 5%	1/4W
R82	1-247-818-11	CARBON 300 5%	1/4W
R83	1-247-834-11	CARBON 1.3K 5%	1/4W
R84	1-249-417-11	CARBON 1K 5%	1/4W
R85	1-249-408-11	CARBON 180 5%	1/4W
< SWITCH >			
S81	1-571-958-11	SWITCH, PUSH (STOP SW)	
S82	1-571-281-21	SWITCH, LEAF (CrO2)	
S83	1-571-281-21	SWITCH, LEAF (MATEL)	
S84	1-571-281-21	SWITCH, LEAF (REC A)	
S85	1-571-281-21	SWITCH, LEAF (REC B)	
S86	1-571-281-21	SWITCH, LEAF (HALF)	

*	A-2006-401-A	AUDIO BOARD (RB12A), COMPLETE (DECK B)	*****
< CAPACITOR >			
C11	1-163-131-00	CERAMIC CHIP 390PF	5% 50V
C12	1-136-157-00	FILM 0.022uF	5% 50V
C13	1-124-234-00	ELECT 22uF	20% 16V
C18	1-163-117-00	CERAMIC CHIP 100PF	5% 50V
C21	1-163-131-00	CERAMIC CHIP 390PF	5% 50V
C22	1-136-157-00	FILM 0.022uF	5% 50V

Ref. No.	Part No.	Description	Remark
C23	1-124-234-00	ELECT 22uF	20% 16V
C28	1-163-117-00	CERAMIC CHIP 100PF	5% 50V
C31	1-124-234-00	ELECT 22uF	20% 16V
C32	1-124-234-00	ELECT 22uF	20% 16V
C33	1-124-234-00	ELECT 22uF	20% 16V
C51	1-164-161-11	CERAMIC CHIP 0.0022uF	10% 100V
C52	1-164-161-11	CERAMIC CHIP 0.0022uF	10% 100V
C53	1-163-019-00	CERAMIC CHIP 0.0068uF	10% 50V
C54	1-136-601-11	FILM 0.01uF	5% 630V
C56	1-164-505-11	CERAMIC CHIP 2.2uF	16V
C57	1-164-346-11	CERAMIC CHIP 1uF	16V
C71	1-164-346-11	CERAMIC CHIP 1uF	16V
C80	1-124-234-00	ELECT 22uF	20% 16V
C81	1-164-232-11	CERAMIC CHIP 0.01uF	50V
C82	1-136-157-00	FILM 0.022uF	5% 50V
C83	1-164-004-11	CERAMIC CHIP 0.1uF	10% 25V
C84	1-136-478-11	FILM 470PF	5% 630V
C85	1-136-433-11	FILM 100PF	5% 630V
C86	1-163-143-00	CERAMIC CHIP 0.0012uF	5% 50V
C87	1-136-273-91	FILM 75PF	5% 630V
C88	1-163-003-11	CERAMIC CHIP 330PF	10% 50V
C89	1-124-234-00	ELECT 22uF	20% 16V
C90	1-107-045-00	MICA 3.9PF	500V
C91	1-164-232-11	CERAMIC CHIP 0.01uF	50V
C92	1-136-157-00	FILM 0.022uF	5% 50V
C93	1-164-004-11	CERAMIC CHIP 0.1uF	10% 25V
C94	1-136-478-11	FILM 470PF	5% 630V
C95	1-136-433-11	FILM 100PF	5% 630V
C96	1-163-143-00	CERAMIC CHIP 0.0012uF	5% 50V
C97	1-136-273-91	FILM 75PF	5% 630V
C98	1-163-003-11	CERAMIC CHIP 330PF	10% 50V
C99	1-164-005-11	CERAMIC CHIP 0.47uF	25V
< CONNECTOR >			
* CNP31	1-580-782-11	CONNECTOR, BOARD TO BOARD	
* CNP32	1-580-781-11	PIN, CONNECTOR (PC BOARD) 7P	
* CNP33	1-580-782-11	CONNECTOR, BOARD TO BOARD	
* CNP71	1-564-719-11	PIN, CONNECTOR (SMALL TYPE) 3P	
* CNP72	1-580-411-11	SOCKET, CONNECTOR 4P	
< DIODE >			
D31	8-719-016-74	DIODE 1SS352	
< IC >			
IC31	8-759-106-02	IC uPC4570G2	
IC81	8-759-106-56	IC uPC1297CA	

AUDIO PANEL

Ref. No.	Part No.	Description	Remark
< COIL >			
L81	1-410-780-11	INDUCTOR 27mH	
L91	1-410-780-11	INDUCTOR 27mH	
< TRANSISTOR >			
Q51	8-729-808-01	TRANSISTOR 2SD1622-S	
Q52	8-729-808-01	TRANSISTOR 2SD1622-S	
Q53	8-729-808-01	TRANSISTOR 2SD1622-S	
Q71	8-729-216-22	TRANSISTOR 2SA1162	
< RESISTOR >			
R11	1-216-099-00	METAL CHIP 120K 5%	1/10W
R12	1-216-025-00	METAL CHIP 100 5%	1/10W
R13	1-216-100-00	METAL GLAZE 130K 5%	1/10W
R14	1-216-067-00	METAL CHIP 5.6K 5%	1/10W
R21	1-216-099-00	METAL CHIP 120K 5%	1/10W
R22	1-216-025-00	METAL CHIP 100 5%	1/10W
R23	1-216-100-00	METAL GLAZE 130K 5%	1/10W
R24	1-216-067-00	METAL CHIP 5.6K 5%	1/10W
R31	1-216-033-00	METAL CHIP 220 5%	1/10W
R32	1-216-033-00	METAL CHIP 220 5%	1/10W
R51	1-216-097-00	METAL CHIP 100K 5%	1/10W
R52	1-216-097-00	METAL CHIP 100K 5%	1/10W
R53	1-216-073-00	METAL CHIP 10K 5%	1/10W
R54	1-216-309-00	METAL CHIP 5.6 5%	1/10W
R55	1-216-309-00	METAL CHIP 5.6 5%	1/10W
R57	1-216-298-00	METAL CHIP 2.2 5%	1/10W
R71	1-216-082-00	METAL GLAZE 24K 5%	1/10W
R72	1-216-081-00	METAL CHIP 22K 5%	1/10W
R73	1-216-089-00	METAL CHIP 47K 5%	1/10W
R74	1-216-089-00	METAL CHIP 47K 5%	1/10W
R81	1-216-073-00	METAL CHIP 10K 5%	1/10W
R82	1-216-085-00	METAL CHIP 33K 5%	1/10W
R83	1-216-001-00	METAL CHIP 10 5%	1/10W
R84	1-216-101-00	METAL CHIP 150K 5%	1/10W
R85	1-216-075-00	METAL CHIP 12K 5%	1/10W
R91	1-216-073-00	METAL CHIP 10K 5%	1/10W
R92	1-216-085-00	METAL CHIP 33K 5%	1/10W
R93	1-216-001-00	METAL CHIP 10 5%	1/10W
R94	1-216-101-00	METAL CHIP 150K 5%	1/10W
R95	1-216-075-00	METAL CHIP 12K 5%	1/10W
< VARIABLE RESISTOR >			
RV11	1-241-627-11	RES. ADJ, CARBON 1K (PB LEVEL L)	
RV21	1-241-627-11	RES. ADJ, CARBON 1K (PB LEVEL R)	
RV71	1-241-630-11	RES. ADJ, CARBON 10K (NORMAL SPEED)	
RV72	1-241-630-11	RES. ADJ, CARBON 10K (HIGH SPEED)	
RV81	1-241-122-11	RES. ADJ, CARBON 22K (RECORD BIAS L)	

Ref. No.	Part No.	Description	Remark
RV91	1-241-122-11	RES. ADJ, CARBON 22K (RECORD BIAS R)	
< RELAY >			
RY31	1-515-913-11	RELAY	
< TRANSFORMER >			
T51	1-406-417-11	COIL, BIAS OSCILLATION	
T81	1-433-381-11	TRANSFORMER, BIAS OSCILLATOR	
T91	1-433-381-11	TRANSFORMER, BIAS OSCILLATOR	
< TEST PIN >			
* TP81	1-568-449-11	HOUSING, CONNECTOR(PC BOARD)3P	

* A-2006-977-A	PANEL BOARD, COMPLETE		

1-690-880-81	LEAD (WITH CONNECTOR)		
< CAPACITOR >			
C551	1-161-494-00	CERAMIC 0.022uF	25V <HEADPHONE BOARD>
C901	1-164-159-11	CERAMIC 0.1uF	50V
C902	1-164-159-11	CERAMIC 0.1uF	50V
C903	1-164-159-11	CERAMIC 0.1uF	50V
C904	1-164-159-11	CERAMIC 0.1uF	50V
< CONNECTOR >			
* CN901	1-568-869-11	SOCKET, CONNECTOR 27P	
* CN902	1-568-854-11	SOCKET, CONNECTOR 11P	
< IC >			
IC901	8-741-100-48	IC SBX1610-59	
< JACK >			
J502	1-507-796-71	JACK (HEADPHONES) <HEADPHONE BOARD>	
< RESISTOR >			
R191	1-247-864-11	CARBON 24K 5%	1/4W
R291	1-247-864-11	CARBON 24K 5%	1/4W
R901	1-249-429-11	CARBON 10K 5%	1/4W
R902	1-249-429-11	CARBON 10K 5%	1/4W
R903	1-249-429-11	CARBON 10K 5%	1/4W
R904	1-249-429-11	CARBON 10K 5%	1/4W
R905	1-249-418-11	CARBON 1.2K 5%	1/4W
R906	1-249-420-11	CARBON 1.8K 5%	1/4W
R907	1-249-422-11	CARBON 2.7K 5%	1/4W
R908	1-249-424-11	CARBON 3.9K 5%	1/4W

PANEL

Ref. No.	Part No.	Description	Remark
R909	1-249-427-11	CARBON	6. 8K 5% 1/4W
R910	1-249-418-11	CARBON	1. 2K 5% 1/4W
R911	1-249-420-11	CARBON	1. 8K 5% 1/4W
R912	1-249-422-11	CARBON	2. 7K 5% 1/4W
R913	1-249-424-11	CARBON	3. 9K 5% 1/4W
R914	1-249-427-11	CARBON	6. 8K 5% 1/4W
R915	1-249-431-11	CARBON	15K 5% 1/4W
R916	1-249-418-11	CARBON	1. 2K 5% 1/4W
R917	1-249-420-11	CARBON	1. 8K 5% 1/4W
R918	1-249-422-11	CARBON	2. 7K 5% 1/4W
R919	1-249-424-11	CARBON	3. 9K 5% 1/4W
R921	1-249-418-11	CARBON	1. 2K 5% 1/4W
R922	1-249-420-11	CARBON	1. 8K 5% 1/4W
R923	1-249-422-11	CARBON	2. 7K 5% 1/4W
R924	1-249-424-11	CARBON	3. 9K 5% 1/4W
R925	1-249-427-11	CARBON	6. 8K 5% 1/4W
R951	1-249-431-11	CARBON	15K 5% 1/4W
< VARIABLE RESISTOR >			
RV901	1-223-373-11	RES, VAR, CARBON 10K (REC LEVEL)	
RV902	1-223-372-11	RES, VAR, CARBON 100K (REC BALANCE)	
< SWITCH >			
S701	1-571-305-11	SWITCH, PUSH (1 KEY) (POWER)	
< POWER SWITCH BOARD >			
S901	1-554-303-21	SWITCH, TACTILE (■:DECK A)	
S902	1-554-303-21	SWITCH, TACTILE (▷:DECK A)	
S903	1-554-303-21	SWITCH, TACTILE (<◁:DECK A)	
S904	1-554-303-21	SWITCH, TACTILE (<◁◁:DECK B)	
S905	1-554-303-21	SWITCH, TACTILE (▷▷:DECK B)	
S906	1-554-303-21	SWITCH, TACTILE (●:DECK B)	
S907	1-554-303-21	SWITCH, TACTILE (■:DECK B)	
S908	1-554-303-21	SWITCH, TACTILE (▣:DECK B)	
S909	1-554-303-21	SWITCH, TACTILE (▷:DECK B)	
S910	1-554-303-21	SWITCH, TACTILE (<◁:DECK B)	
S911	1-554-303-21	SWITCH, TACTILE (●:DECK B)	
S912	1-554-303-21	SWITCH, TACTILE (<◁:DECK A)	
S913	1-554-303-21	SWITCH, TACTILE (▷▷:DECK A)	
S915	1-554-303-21	SWITCH, TACTILE (COUNTER RESET:DECK A)	
S916	1-554-303-21	SWITCH, TACTILE (AUTO CAL)	
S917	1-554-303-21	SWITCH, TACTILE (HIGH)	
S918	1-554-303-21	SWITCH, TACTILE (NORMAL)	
S919	1-554-303-21	SWITCH, TACTILE (COUNTER RESET:DECK B)	
S921	1-692-126-11	SWITCH, SLIDE (DOLBY NR ON/OFF)	
S922	1-692-126-11	SWITCH, SLIDE (DOLBY NR B/C)	
S923	1-692-126-11	SWITCH, SLIDE (DIR MODE)	

Ref. No.	Part No.	Description	Remark
< FILTER >			
VFD901	1-517-162-11	INDICATOR TUBE, FLUORESCENT	
***** MISCELLANBOUS *****			
1	1-690-906-11	WIRE (FLAT TYPE) (9 CORE)	
* 2	1-575-781-11	WIRE, FLAT TYPE (9 CORE)	
△12	1-551-188-XX	CORD, POWER (E)	
△12	1-558-945-21	CORD, POWER (POLAR. SPT-1) (US, Canadian)	
△12	1-575-651-21	CORD, POWER (AEP, G)	
△12	1-696-586-11	CORD, POWER (UK)	
△12	1-696-845-11	CORD, POWER (AUS)	
△14	1-569-007-11	ADAPTER, CONVERSION 2P (E)	
72	1-690-911-11	WIRE (FLAT TYPE) (11 CORE)	
73	1-575-628-11	WIRE, FLAT TYPE (27 CORE)	
121	1-638-983-11	PC BOARD, MOTOR FLEXIBLE	
△F701	1-532-285-00	FUSE, TIME LAG (1. 250A) (AEP, UK, E, G, AUS)	
△F701	1-576-103-11	FUSE (1. 600A) (US, Canadian)	
△F702	1-532-285-00	FUSE TIME LAG (1. 250A) (AEP, UK, E, G, AUS)	
△F702	1-576-103-11	FUSE (1. 600A) (US, Canadian)	
HP101	A-2003-837-F	BASE ASSY, HEAD (DECK A) (PLAYBACK)	
HRPE101	A-2003-838-A	BASE ASSY, HEAD (DECK B) (PLAYBACK/RECORD/ERASE)	
IC81	8-719-710-03	DIODE NJL516K-B	
M1	X-3359-417-1	MOTOR (CAPSTAN) ASSY	
M2	X-3363-501-1	MOTOT ASSY, REEL	
△T701	1-450-837-41	TRANSFORMER, POWER (US, Canadian)	
△T701	1-450-838-41	TRANSFORMER, POWER (AEP, UK, G, AUS)	
△T701	1-450-839-11	TRANSFORMER, POWER (E)	
△VS701	1-692-155-11	SELECTOR, POWER VOLTAGE (VOLTAGE) (E)	

ACCESSORIES & PACKING MATERIALS *****			
	1-558-271-11	CORD, CONNECTION	
	1-558-271-11	CORD, CONNECTION	
	1-696-170-11	CORD, CONNECTION	
*	3-376-446-01	CUSHION	
*	3-388-323-01	INDIVIDUAL CARTON	
	3-756-406-11	MANUAL, INSTRUCTION (ENGLISH/FRENCH/SPANISH/PORTUGUESE) (AEP, E)	
	3-756-406-21	MANUAL, INSTRUCTION (ENGLISH) (US, Canadian, UK, AUS)	
	3-756-406-31	MANUAL, INSTRUCTION (FRENCH) (Canadian)	

The components identified by mark △ or dotted line with mark △ are critical for safety. Replace only with part number specified.

Les composants identifiés par une marque △ sont critiques pour la sécurité. Ne les remplacer que par une pièce portant le numéro spécifié.

<u>Ref. No.</u>	<u>Part No.</u>	<u>Description</u>	<u>Remark</u>
	3-756-406-41	MANUAL, INSTRUCTION (GERMAN/DUTCH/SWEDISH/ITALIAN) (AEP)	
	3-756-406-51	MANUAL, INSTRUCTION (GERMAN) (G)	
	3-756-406-61	MANUAL, INSTRUCTION (CHINESE) (E)	

HARDWARE LIST

#1	7-682-548-09	SCREW +BVTT 3X8 (S)	
#2	7-682-548-04	SCREW +BVTT 3X8 (S)	
#3	7-685-646-79	SCREW +BVTP 3X8 TYPE2 IT-3	
#4	7-685-871-01	SCREW +BVTT 3X6 (S)	
#5	7-621-773-95	SCREW +BVTT 2.6X6 (S)	
#6	7-685-134-19	SCREW (+ PTPWH) (2.6X8)	
#7	7-621-849-00	SCREW (BV/RING)	
#8	7-627-556-08	SCREW +P 2.6X2.8	
#9	7-621-775-00	SCREW +B 2.6X3	

