

TC-W320/W320S/WR520/WR520S

SERVICE MANUAL

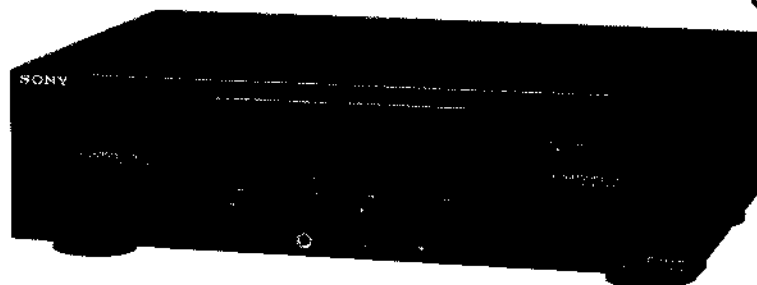

TC-WR520

US Model
TC-W320/W320S/WR520/WR520S

Canadian Model
AEP Model
E Model
TC-W320/WR520

UK Model
TC-W320

SPECIFICATIONS

Recording system 4-track 2-channel stereo
Fast-forward and rewind time
Approx. 90 sec. (with HF-60 cassette)
Bias AC bias
Signal-to-noise ratio (NAB, at peak level)

Dolby NR switch Cassette	OFF	B-TYPE ON	C-TYPE ON
TYPE IV (Sony METAL-ES)	58 dB	66 dB	73 dB
TYPE II (Sony UX-S)	57 dB	65 dB	72 dB
TYPE I (Sony HF-S)	55 dB	63 dB	70 dB

Total harmonic distortion 1.0% (with Sony METAL-ES cassette)
Frequency response (Dolby NR off)

TYPE IV cassette (Sony METAL-ES)	30 - 15,000 Hz (± 3 dB) 30 - 13,000 Hz (OVU recording)
TYPE II cassette (Sony UX-S)	30 - 15,000 Hz (± 3 dB)
TYPE I cassette (Sony HF-S)	30 - 14,000 Hz (± 3 dB)

Wow and flutter 0.08% WRMS (NAB)
Inputs

Line inputs (phono jacks)	Sensitivity	77.5 mV (-20 dB)
	Input impedance	50 kohms

Outputs

Line outputs (phono jacks)	Rated output level	0.44 V (-5 dB) at a load impedance 47 kohms
	Load impedance	Over 10 kohms
Headphones (stereo phone jack)	Output level	0.3 mW at a load impedance of 32 ohms

Model Name Using Similar Mechanism	New Mechanism		
Tape Transport Mechanism Type	TC-W320 /W320S	DECK A	TCM-190VA12
		DECK B	TCM-190VB22
	TC-WR520 /WR520S	DECK A	TCM-190RA12
		DECK B	TCM-190RB22

General

Power requirements US, Canadian model : 120V AC, 60Hz
AEP, West Germany model : 220V
AC, 50/60Hz
UK model : 240V AC, 50/60Hz
E model : 120, 220, 240V
AC adjustable, 50/60Hz

Power consumption 23 W

Dimensions Approx. 430 x 125 x 285 mm (w/h/d)
(17 x 5 x 11 $\frac{1}{4}$ inches)
including projecting parts and
controls

Weight Approx. 4.5 kg (9 lbs 15 oz)

Supplied accessory

Audio connecting cord (2)

Design and specifications subject to change without
notice.

Dolby noise reduction manufactured under license from
Dolby Laboratories Licensing Corporation.
"DOLBY" and the double-D symbol  are trademarks of
Dolby Laboratories Licensing Corporation.

STEREO CASSETTE DECK
SONY[®]

SECTION 1 GENERAL

Identification of Front Panel Parts

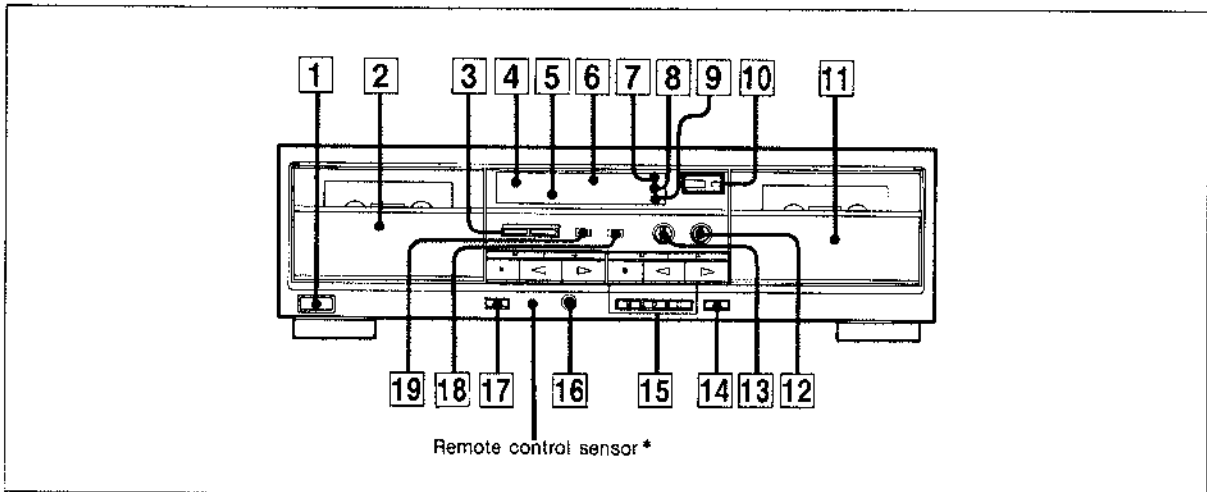

- | | |
|---|---|
| <p>1 POWER switch</p> <p>2 Cassette holder (deck A)</p> <p>3 SYNCHRO DUBBING buttons
HIGH SPEED button/NORM. (normal) SPEED button</p> <p>4 PLAY and < > Direction indicators (deck A)</p> <p>5 Peak level meter</p> <p>6 SYNCHRO DUBBING indicators</p> <p>7 PLAY and < > Direction indicators (deck B)</p> <p>8 Pause indicator</p> <p>9 REC (recording) indicator</p> <p>10 Tape COUNTER and RESET button</p> <p>11 Cassette holder (deck B)</p> <p>12 REC (recording) LEVEL control</p> <p>13 BALANCE control</p> | <p>14 ▲ (eject) button (deck B)</p> <p>15 Tape operation buttons
■ (stop) button
◀ (reverse play) button (TC-WR520/WR520S only)
▶ (forward play) button
▶▶ (right fast winding) button
◀◀ (left fast winding) button
● REC (recording) button (deck B only)
○ REC MUTE (recording muting) button (deck B only)
 PAUSE button (deck B only)</p> <p>16 PHONES (headphones) jack (stereo phone jack)</p> <p>17 ▲ (eject) button (deck A)</p> <p>18 □ NR (Dolby noise reduction) switch</p> <p>19 DIR (direction) MODE switch (TC-WR520/WR520S only)</p> <p>*Remote control sensor
You can remotely control this cassette deck with:
—A remote commander that has an R mark and comes with a Sony amplifier or receiver and which can be used to control a cassette deck.
—An optional Sony remote commander that has an R mark.</p> |
|---|---|

SECTION 2 DISASSEMBLY

Note: Follow the disassembly procedure in the numerical order given.

[FRONT PANEL]

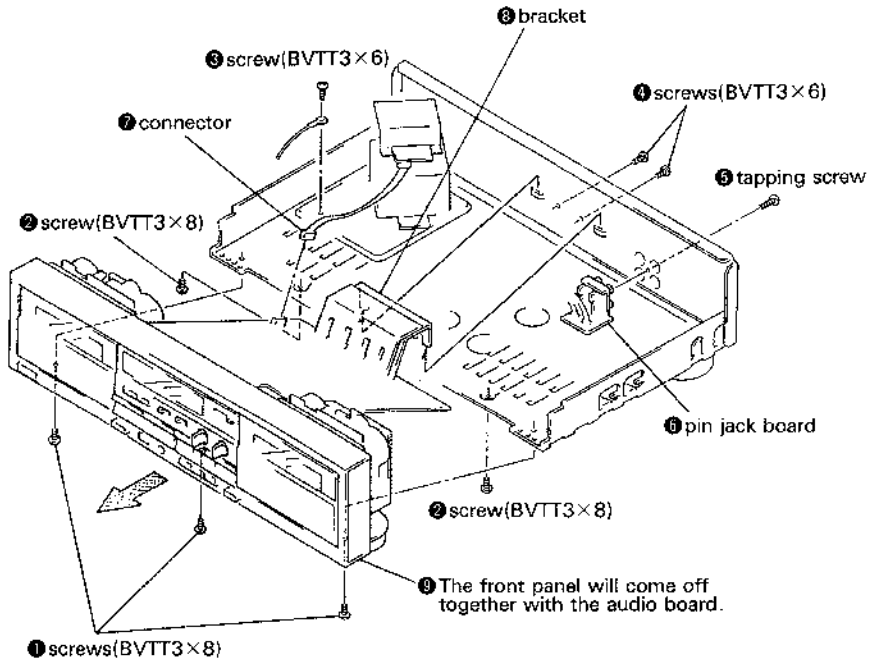

[MECHANISM BLOCK]

1 Press the eject button and remove the cassette lid by sliding it upward.

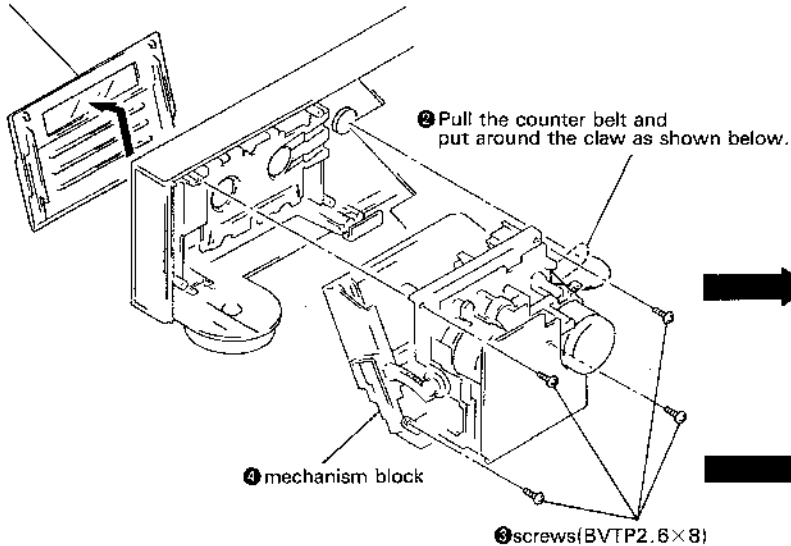

Remove the cassette holder assembly.

[HEAD]

(W320, W320S)

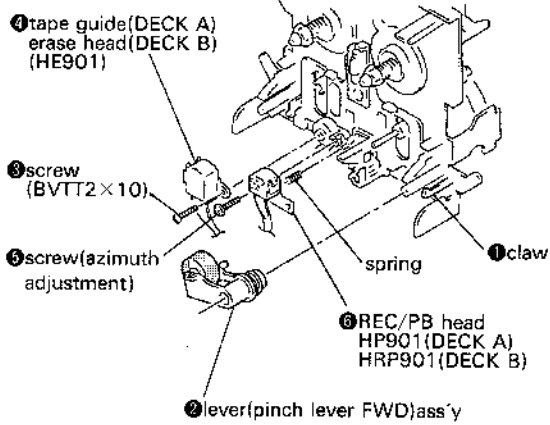

(WR520, WR520S)

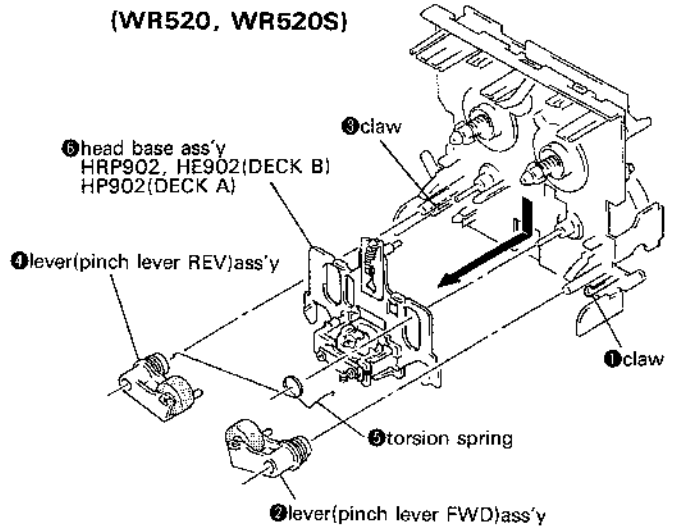

[FITTING BASE BLOCK]

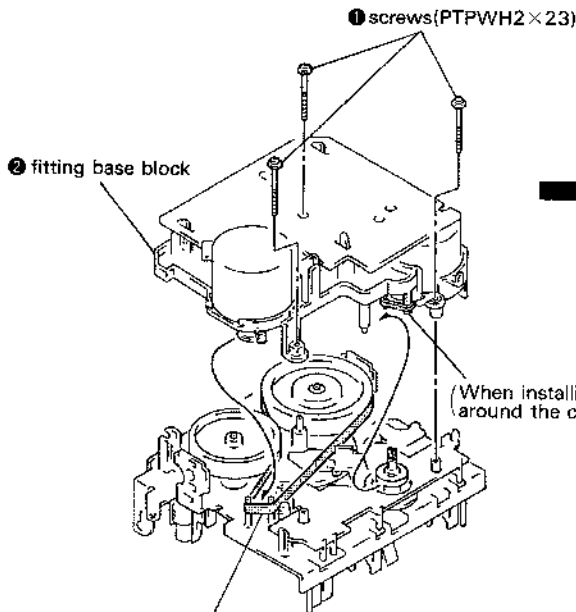

(When installing, pull the capstan belt and put around the claws as shown below.)

[MOTOR]

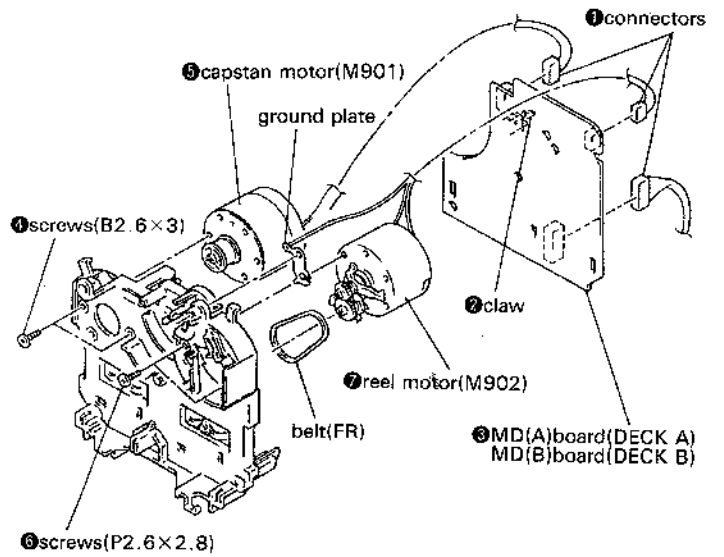

(When installing, pull the FR belt and put around the claws as shown below.)

SECTION 3 ADJUSTMENTS

3-1. MECHANICAL ADJUSTMENTS

PRECAUTION

1. Clean the following parts with a denatured-alcohol-moistened swab:

record/playback head	pinch roller
erase head	rubber belts
capstan	idler
2. Demagnetize the record/playback head with a head demagnetizer.
3. Do not use a magnetized screwdriver for the adjustments
4. After the adjustments, apply suitable locking compound to the parts adjusted.
5. The adjustments should be performed in the rated power supply voltage unless otherwise noted.

Torque Measurement

Torque	Torque meter	Meter reading
FWD	CQ-102C	35 to 60g · cm (0.49 to 0.83 oz · inch)
FWD Back tension	CQ-102C	1 to 5g · cm (0.014 to 0.06 oz · inch)
REV	CQ-102RC	35 to 60g · cm (0.49 to 0.83 oz · inch)
REV Back tension	CQ-102RC	1 to 5g · cm (0.014 to 0.06 oz · inch)
FF, REW	CQ-201B	70 to 110g · cm (0.98 to 1.52 oz · inch)

3-2. ELECTRICAL ADJUSTMENT

Note: The adjustment should be performed in the order given in the service manual. As a rule, adjustment about playback should be performed before adjustment about recording.

The adjustments should be performed for both L-CH and R-CH.

- Switches and controls should be set as follows unless otherwise specified.

□ NR switch : OFF

DIR MODE switch : →

- Standard Record:

Deliver the standard input signal level to the input jack and set the REC LEVEL control to obtain the standard output signal level.

- Record Mode -

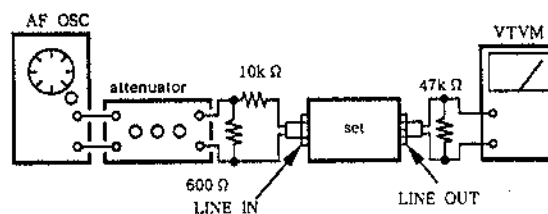

Standard Input Level

input terminal	LINE IN
source impedance	10kΩ
input level	0.25V (-10dB)

Standard Output Level

output terminal	LINE OUT
load impedance	47kΩ
output level	0.44V (-5dB)

Test tape

Type	Signal	Used for
P-4-A100	10kHz, -10dB	Azimuth Adjustment
P-4-L300	315Hz, 0dB	PB Level Adjustment
WS-48B	3kHz, 0dB	Tape Speed Adjustment

Record/Playback Head Azimuth Adjustment

DECK A **DECK B**

Procedure :

1. Mode: FWD playback

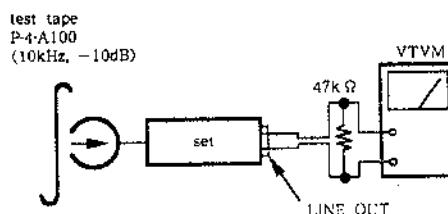

- Turn the adjustment screw for the maximum output levels. If these levels do not match, turn the adjustment screw until both of output levels match together within 1dB.

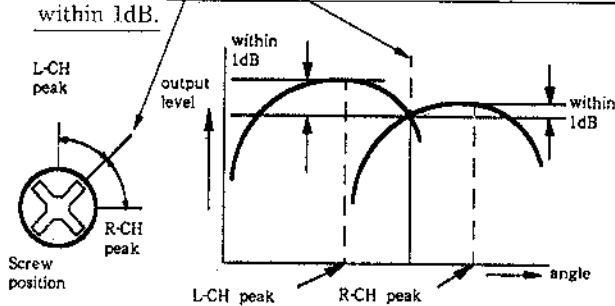

- Phase Check
Mode: playback

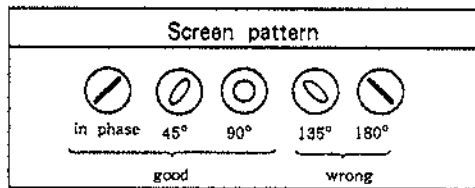
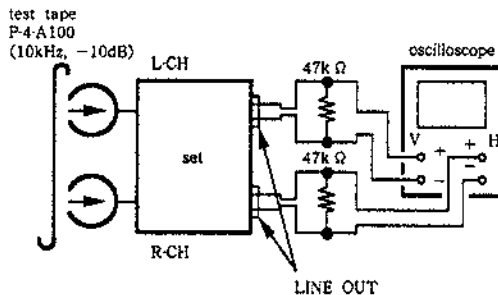

- Set in the REV mode and repeat the step 1-3. (WR520)
- After the adjustment, lock the screws with locking compound.

Adjustment Location: Record/playback head

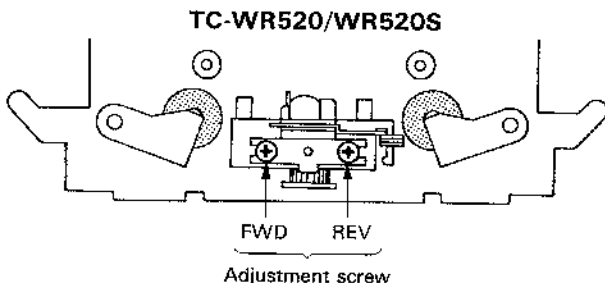
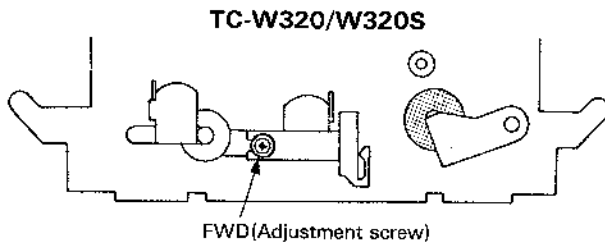

Tape Speed Adjustment **DECK A** **DECK B**

Procedure:

Mode: playback

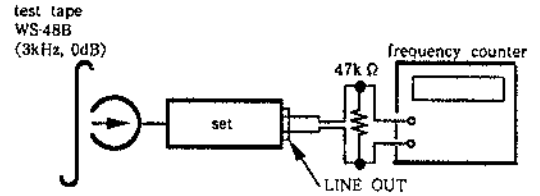

Perform high speed adjustment before normal speed adjustment.

(high speed adjustment)

- Short test pin CN805 on audio board and turn POWER switch on.
- Set to FWD playback mode.
- Keep on pressing the HIGH SPEED DUBBING switch.
- Adjust RV72A, B so that the frequency counter reading becomes $6,000 \pm 20\text{Hz}$.
- After adjustment, disconnect CN805 shorted in step 1.

(normal speed adjustment)

- Set to FWD playback mode.
- Adjust RV71A, B so that the frequency counter reading becomes $3,000 \pm 10\text{Hz}$.

Frequency difference between the beginning and the end of the tape should be within 3%.

Frequency difference between deck A and deck B the beginning of the tape should be within 1.5%.

Adjustment Location:

MD(A), MD(B) board

Playback Level Adjustment

DECK A DECK B

Procedure :

Mode: playback

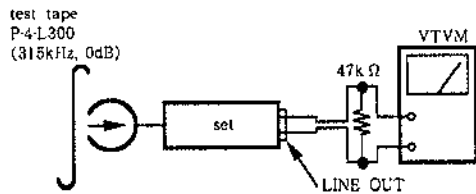

Adjust RV11A, B (L-CH), RV21A, B (R-CH) so that the reading on VTVM meets the adjustment limits below.

Adjustment Limits :

LINE OUT level: $-5 \pm 0.5\text{dB}$ (0.42–0.46V)

Level difference between channels: less than 0.5dB

Check that the LINE OUT level does not change in playback mode while changing the mode from playback to stop several times.

Adjustment Location : MD(A), MD(B) board

Record Bias Adjustment DECK B

Setting :

REC LEVEL control: Standard Record (See page 6.)

Procedure :

1. Mode: record

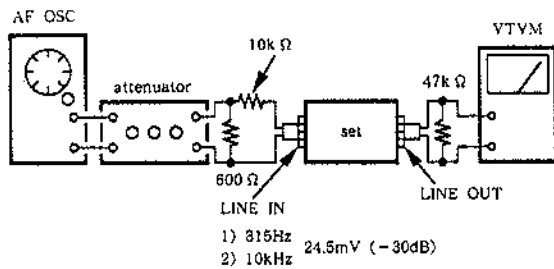

2. Mode: playback

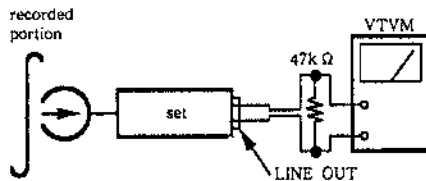

Playback the signal recorded in step 1. Confirm that the 10kHz playback output is $0 \pm 0.5\text{dB}$ relative to the 315Hz output. If necessary, adjust RV12 (L-CH), RV22 (R-CH) and repeat the steps given above.

Adjustment Location : MD(A), MD(B) board

Record Level Adjustment DECK B

Setting :

REC LEVEL control: Standard Record (See page 6.)

Procedure :

1. Mode: record

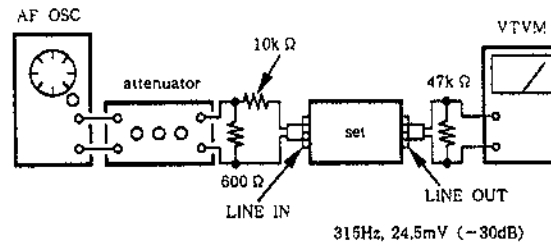

2. Mode: playback

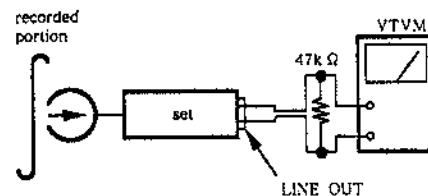

3. Playback the signal recorded in step 1.

Confirm that the signal level is within the adjustment limits below. If necessary, adjust RV101 (L-CH), RV 201 (R-CH) and repeat the step1-2.

Adjustment Limits : $-25\text{dB} \pm 0.5\text{dB}$ (42–46mV)

Adjustment Location : audio board (component side)

Adjustment Parts Location Diagrams

B DECK

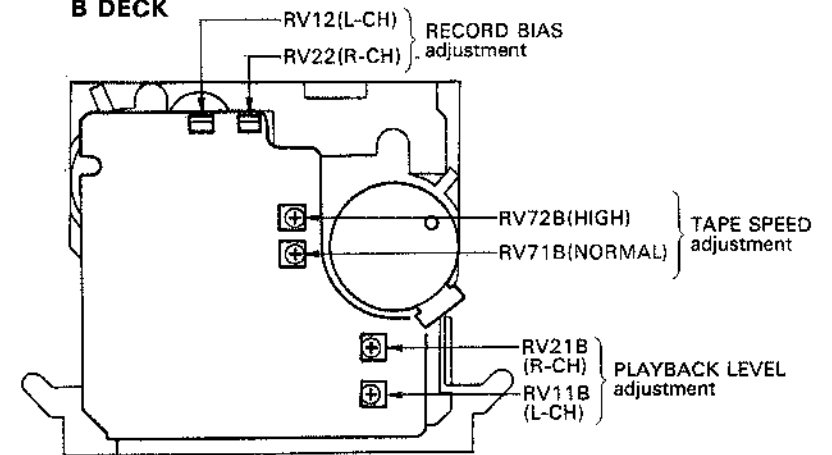

A DECK

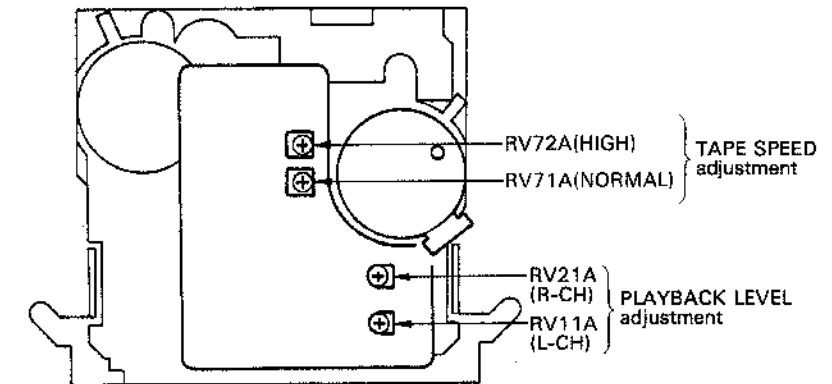

AUDIO BOARD (COMPONENT SIDE)

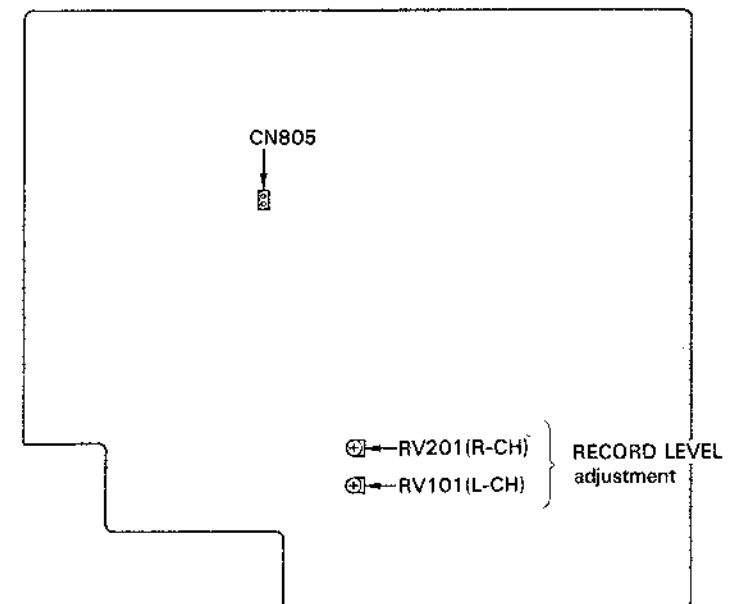

**SECTION 4
DIAGRAMS**

SEMICONDUCTOR LOCATION

Ref. No.	Location	Ref. No.	Location
D31	G-25	IC507	F-9
D101	F-8	IC701	D-6
D102	E-8	IC801	C-11
D201	E-8	IC802	B-11
D202	E-8	IC901	C-21
D301	C-18		
D302	D-18	Q71A	B-24
D304	D-18	Q71B	G-24
D305	E-18	Q51	G-23
D306	E-18	Q52	G-24
D307	E-18	Q53	G-24
D401	C-18	Q101	G-8
D402	D-18	Q102	I-8
D403	D-18	Q103	G-10
D404	D-18	Q201	F-8
D405	E-18	Q202	G-7
D406	E-18	Q203	F-10
D407	E-18	Q501	H-9
D501	D-8	Q502	I-8
D502	C-8	Q503	G-10
D503	C-8	Q505	D-11
D701	C-6	Q506	D-11
D702	C-6	Q507	D-9
D703	C-6	Q508	D-9
D704	C-6	Q509	E-9
D705	C-7	Q510	E-9
D706	C-7	Q511	E-9
D707	D-6	Q701	C-5
D708	C-5	Q702	D-5
D709	E-6	Q703	B-5
D710	D-6	Q704	F-6
D801	C-8	Q705	E-5
D802	C-9	Q706	F-5
D901	F-18	Q801	D-13
D902	F-18	Q802	D-13
D903	F-18	Q803	D-12
D904	F-17	Q804	E-11
D905	F-17	Q805	D-9
D906	D-18	Q806	D-10
D907	C-18	Q807	D-12
D908	B-18	Q808	C-13
D909	B-17	Q809	C-13
D910	B-17	Q810	C-13
		Q811	C-13
		Q812	C-13
IC31A	C-25	Q813	D-13
IC31B	H-25	Q814	D-13
IC81A	D-30	Q815	B-13
IC81B	I-30	Q816	C-9
IC501	H-6	Q817	C-9
IC502	G-11	Q818	C-9
IC503	H-11	Q819	D-9
IC504	I-9	Q820	B-12
IC505	D-8		
IC506	E-8		

Note:
 ● : parts extracted from the component side.
 ○ : parts extracted from the conductor side.
 ○ : indicates side identified with part number.
 ● CND : Canadian model
 ● WG : West Germany model

4-1. PRINTED WIRING BOARDS

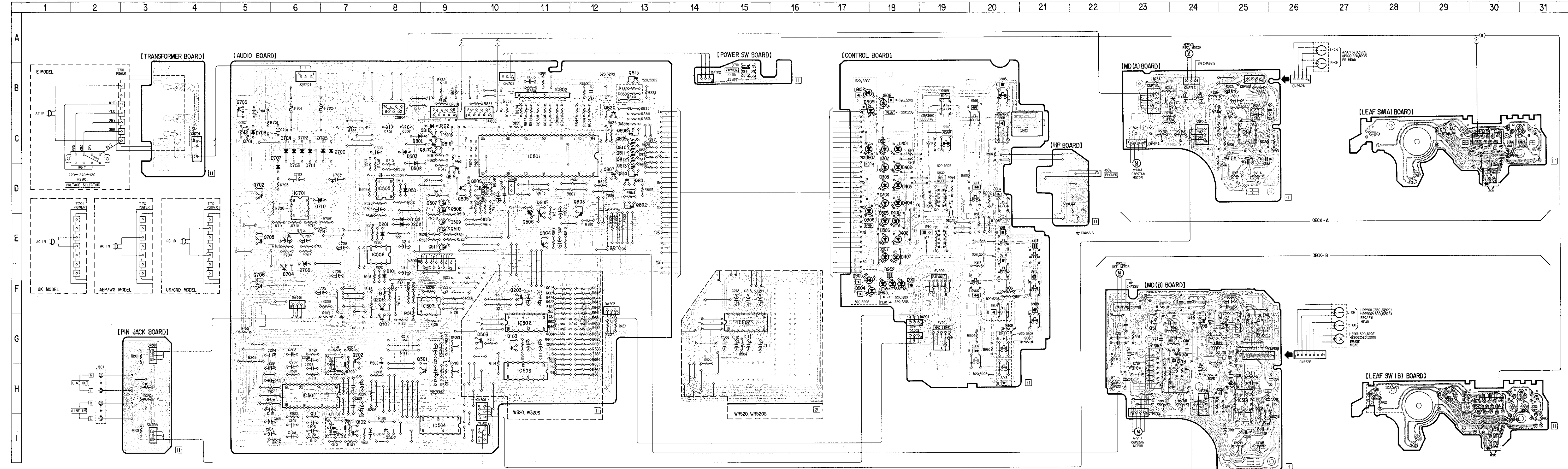

4-2. SCHEMATIC DIAGRAM System Control Section

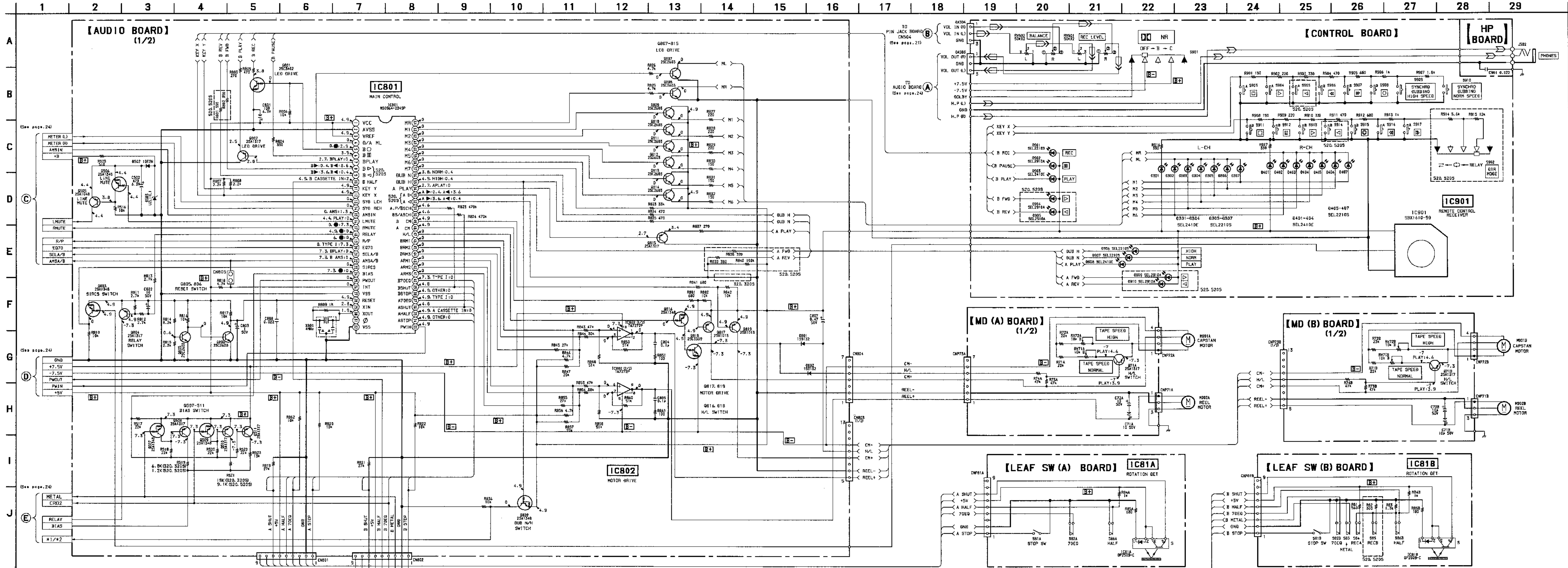

Note:

- All capacitors are in μF unless otherwise noted. $\text{pF} = \mu\text{F} / 100$.
- 50VW or less are not indicated except for electrolytics and tantalums.
- All resistors are in Ω and $1/4\text{W}$ or less unless otherwise specified.
- % : indicates tolerance.
- --- : fusible resistor.

Note: The components identified by mark Δ or dotted line with mark Δ are critical for safety. Replace only with part number specified.

Note: Les composants identifiés par une marque Δ sont critiques pour la sécurité. Ne les remplacer que par une pièce portant le numéro spécifié.

- \square : adjustment for repair.
- Voltage and waveforms are dc with respect to ground under no-signal
- no mark: STOP
- \blacktriangleright : FWD
- \blacktriangleleft : REV
- \bullet : REC
- Voltages are taken with a VOM (input impedance 10M Ω). Voltage variations may be noted due to normal production tolerances.
- Signal path:
 - --- : PB (DECK A)
 - --- : PB (DECK B)
 - --- : REC (DECK B)
- CND : Canadian model
- WG : West Germany model

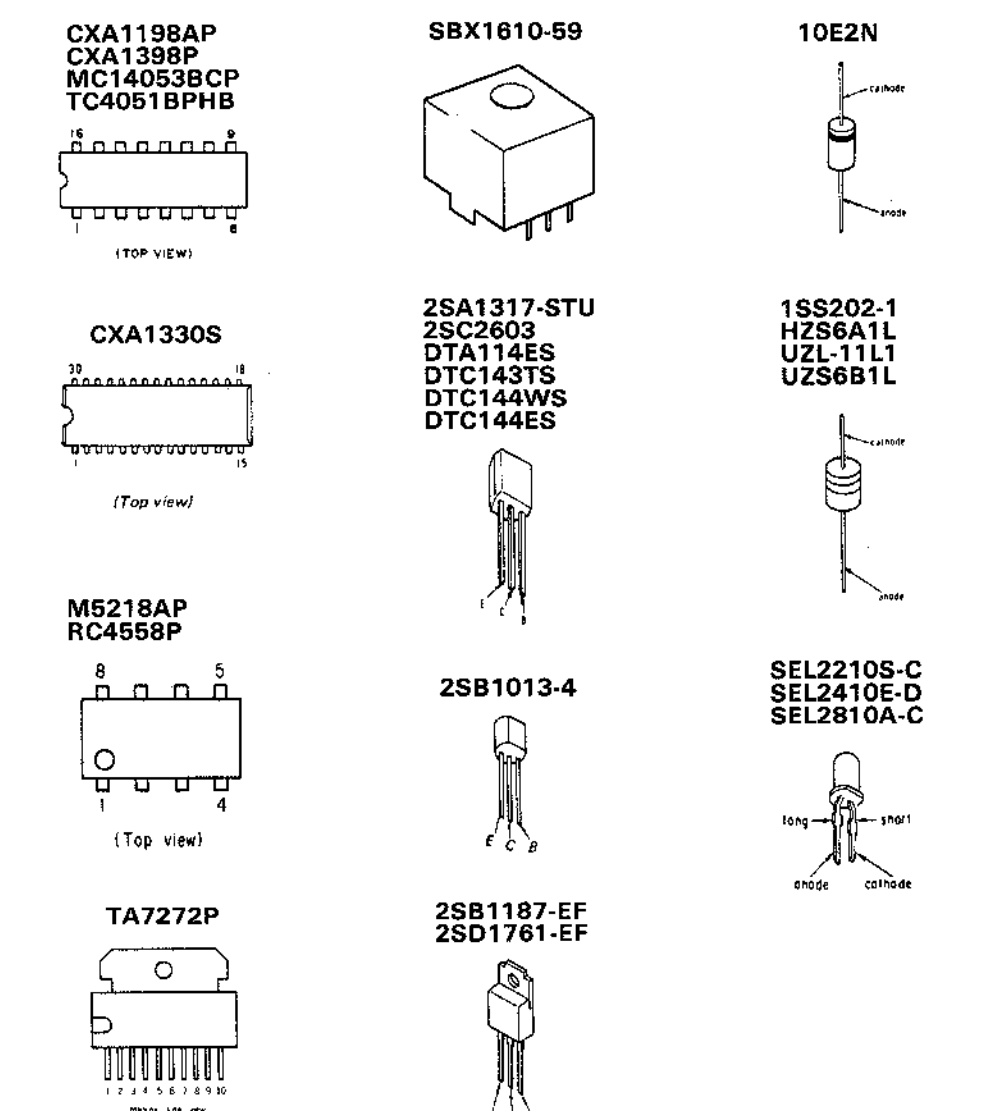
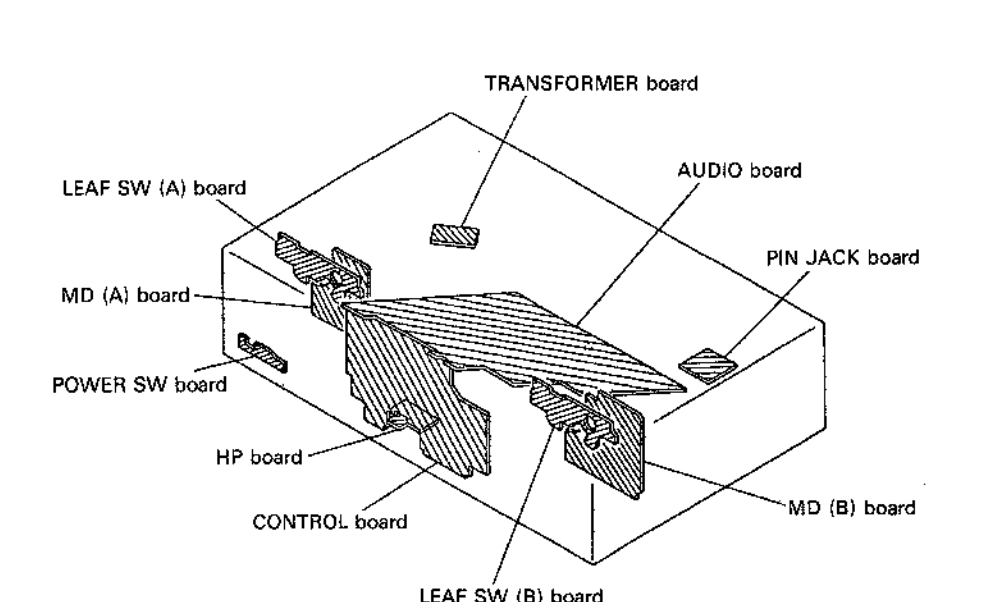
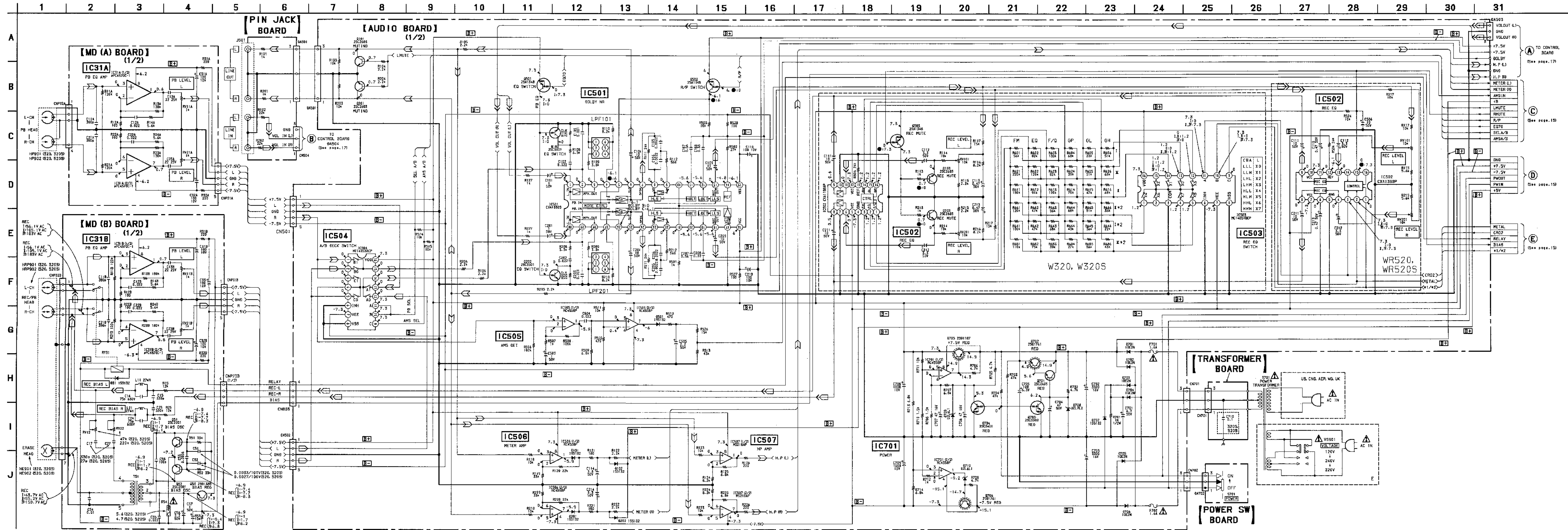

5-2. FRONT PANEL SECTION

- A: CONTROL board
- B: HP board
- C: POWER SW board

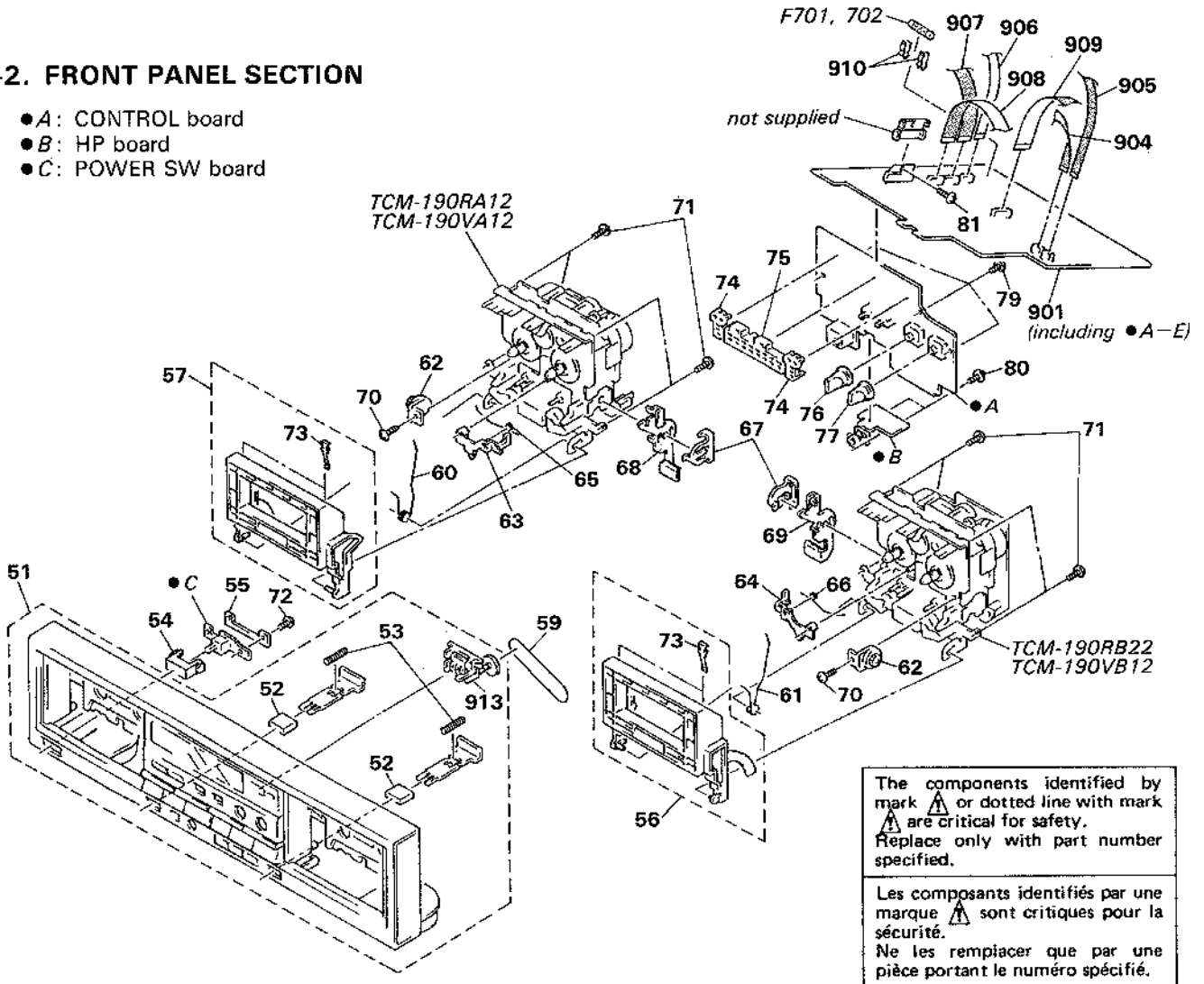

No.	Part No.	Description	Remarks	No.	Part No.	Description	Remarks
51	X-3346-306-1	(520:E,AEP,WG) ...PANEL ASSY, FRONT	52,53,913	74	*3-354-966-01	HOLDER (DIR), LED	
	X-3346-307-1	(320:US,Canadian,320S) ...PANEL ASSY, FRONT	52,53,913	75	*3-354-972-01	HOLDER (METER), LED	
	X-3346-308-1	(320:E,AEP,WG,UK) ...PANEL ASSY, FRONT	52,53,913	76	3-354-968-01	KNOB (RT)(BALANCE)	
	X-3346-309-1	(520:US,Canadian,520S) ...PANEL ASSY, FRONT	52,53,913	77	3-354-968-11	KNOB (RT)(REC LEVEL)	
52	3-359-907-01	BUTTON (EJECT)		79	4-928-635-01	SCREW, +BV (2.6X8) TAPPING	
53	3-359-906-01	SPRING, COMPRESSION		80	7-685-134-19	SCREW (+ PTPWH)(2.6X8)	
54	3-354-932-01	BUTTON (POWER)		81	7-682-547-04	SCREW +BVTT 3X6 (S)	
55	3-359-910-01	REINFORCEMENT		901	*A-2006-250-A	(320)...MOUNTED PCB, AUDIO	
56	X-3340-194-1	HOLDER (L) ASSY, CASSETTE	73		*A-2006-251-A	(520)...MOUNTED PCB, AUDIO	
57	X-3340-195-1	HOLDER (R) ASSY, CASSETTE	73		*A-2006-301-A	(520S)...MOUNTED PCB, AUDIO	
59	3-305-524-00	BELT			*A-2006-302-A	(320S)...MOUNTED PCB, AUDIO	
60	3-354-960-01	SPRING (LOADING R), TORSION		904	1-575-847-11	WIRE, FLAT TYPE (5 CORE)	
61	3-354-959-01	SPRING (LOADING L), TORSION		905	1-575-779-11	WIRE, FLAT TYPE (5 CORE)	
62	3-354-963-01	DAMPER		906	1-575-968-11	WIRE, FLAT TYPE (7 CORE)	
63	3-354-956-01	LEVER (EJ SAFTY LEVER R)		907	1-575-781-11	WIRE, FLAT TYPE (9 CORE)	
64	3-354-955-01	LEVER (EJ SAFTY LEVER L)		908	1-575-782-11	WIRE, FLAT TYPE (9 CORE)	
65	3-354-962-01	SPRING (EJ SAFTY SPRING R)		909	1-575-784-11	WIRE, FLAT TYPE (13 CORE)	
66	3-354-961-01	SPRING (EJ SAFTY SPRING L)		910	1-533-213-31	HOLDER, FUSE	
67	3-354-957-01	JOINT (LOCK LEVER)		913	1-548-596-31	COUNTER, TAPE (MIDDLE TYPE)	
68	*3-354-954-01	LEVER (LOCK LEVER R)		F701	Δ.1-532-259-00	(E,AEP,WG,UK)...FUSE, TIME-LAG 1.6A	
69	*3-354-953-01	LEVER (LOCK LEVER L)		F701	Δ.1-532-742-11	(US,Canadian)...FUSE, GLASS TUBE 1.6A	
70	7-621-773-95	SCREW +BVTT 2.6X6 (S)		F702	Δ.1-532-259-00	(E,AEP,WG,UK)...FUSE, TIME-LAG 1.6A	
71	4-928-635-01	SCREW, +BV (2.6X8) TAPPING		F702	Δ.1-532-742-11	(US,Canadian)...FUSE, GLASS TUBE 1.6A	
72	4-928-635-21	SCREW, +BV (2.6X10) TAPPING					
73	3-308-823-11	SPRING					

5-3. MECHANISM SECTION 1

- TCM-190RA12 DECK A □ TC-WR520, WR520S
- TCM-190RB22 DECK B □ TC-WR520, WR520S
- TCM-190VA12 DECK A □ TC-W320, W320S
- TCM-190VB22 DECK B □ TC-W320, W320S

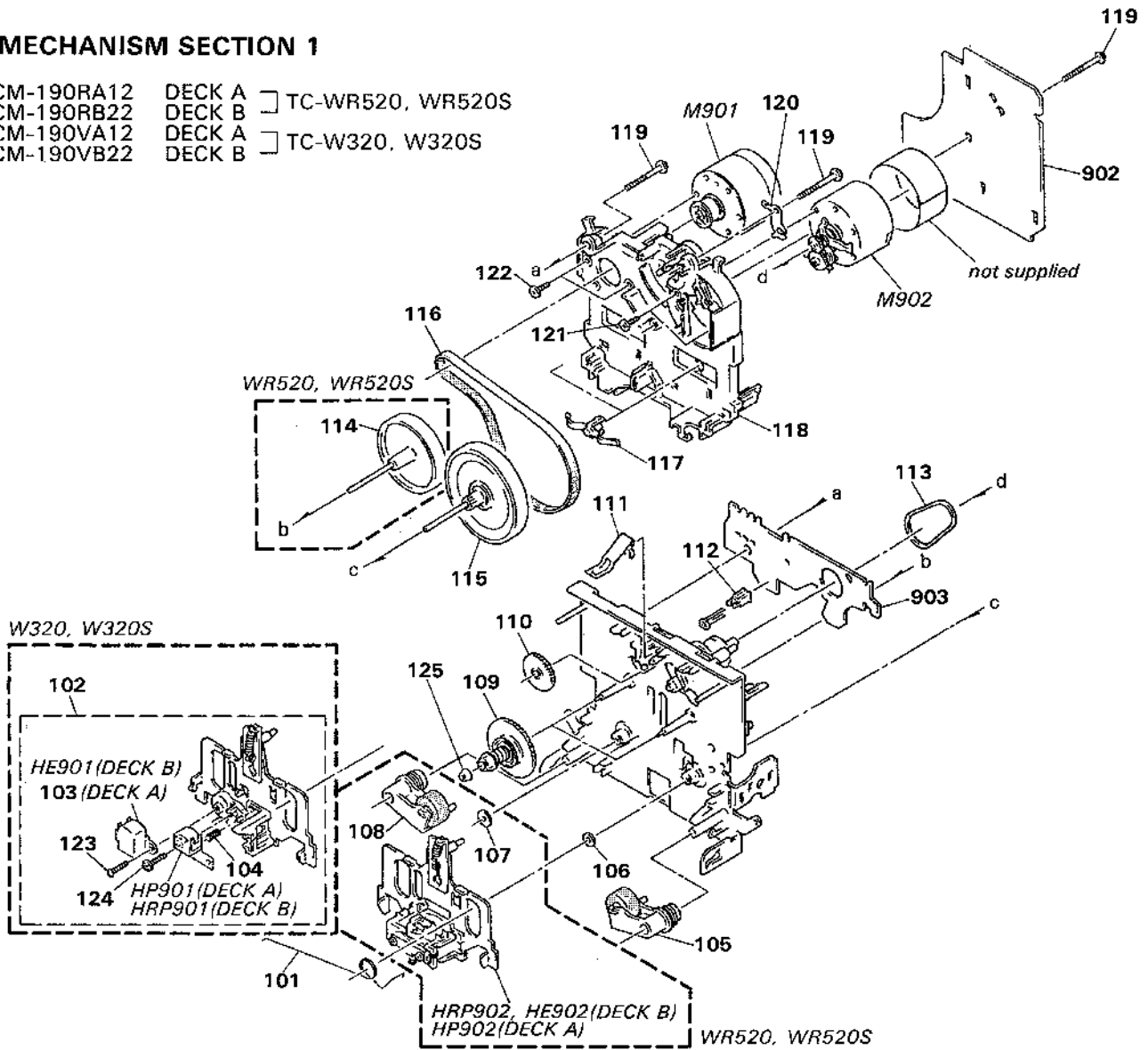

No.	Part No.	Description	Remarks	No.	Part No.	Description	Remarks
101	3-359-455-01	SPRING, TORSION		120	3-359-450-01	PLATE, GROUND	
102	A-2003-475-A	(320,320S DECK A)...BASE(ONE) ASSY, HEAD		121	7-627-556-08	SCREW +P 2.6X2.8	
	A-2003-476-A	(320,320S DECK B)...BASE(ONE) ASSY, HEAD		122	7-621-775-00	SCREW +B 2.6X3	
103	3-319-716-01	(320,320S DECK A)...GUID, TAPE		123	7-621-255-65	(320,320S)...+BVTT 2X10 (S)	
104	3-343-484-01	(320,320S)...SPRING, COMPRESSION		124	3-359-446-01	SCREW(AZIMUTH ADJUSTMENT)	
105	X-3359-406-1	LEVER (PINCH LEVER FWD) ASSY		125	3-356-618-01	CAP(REEL)	
106	3-356-713-01	WASHER		902	*1-634-840-11	(DECK A)...PC BOARD, MD (A)	
107	3-356-714-01	(520,520S)...WASHER			*1-634-843-11	(DECK B)...PC BOARD, MD (B)	
108	X-3359-409-1	(520,520S)...LEVER(PINCH LEVER REV) ASSY		903	*1-634-841-11	PC BOARD, LEAF SW	
109	X-3359-404-1	TABLE ASSY, REEL		HE901	1-543-535-11	(320,320S DECK B)...HEAD, MAGNETIC (ERASE)	
110	3-359-424-01	GEAR (REV GEAR)		HP901	1-543-536-11	(320,320S DECK A)...HEAD, MAGNETIC (PLAYBACK)	
111	3-359-430-01	SPRING(CASSETTE RETAINER),LEAF		HP902	A-2003-418-A	(520,520S DECK A)...BASE ASSY, HEAD	
112	3-343-419-01	HOLDER (S SENS R A)		HRP901	1-543-537-11	(320,320S DECK B)...HEAD, MAGNETIC (REC/PB)	
113	3-359-466-01	BELT (FR), SQUARE		HE902	A-2003-477-A	(520,520S DECK B)...BASE ASSY, HEAD (REC/PB/ERASE)	
114	X-3359-410-1	(520,520S)...FLYWHEEL (REV) ASSY		HRP902			
115	X-3359-406-1	FLYWHEEL (FWD) COMPLETE ASSY		M901	X-3359-417-1	MOTOR ASSY	
116	3-359-417-01	(520,520S)...BELT (FLAT), CAPSTAN		M902	A-2003-474-A	MOTOR (REEL MOTOR) ASSY	
	3-359-467-01	(320,320S)...BELT (1 WAY FLAT BELT)					
117	3-575-321-00	RETAINER, THRUST, CAPSTAN					
118	*3-359-436-01	BASE (THRUST RETAINER),FITTING					
119	3-359-414-01	SCREW (+PTPMH 2X23)					

5-4. MECHANISM SECTION 2

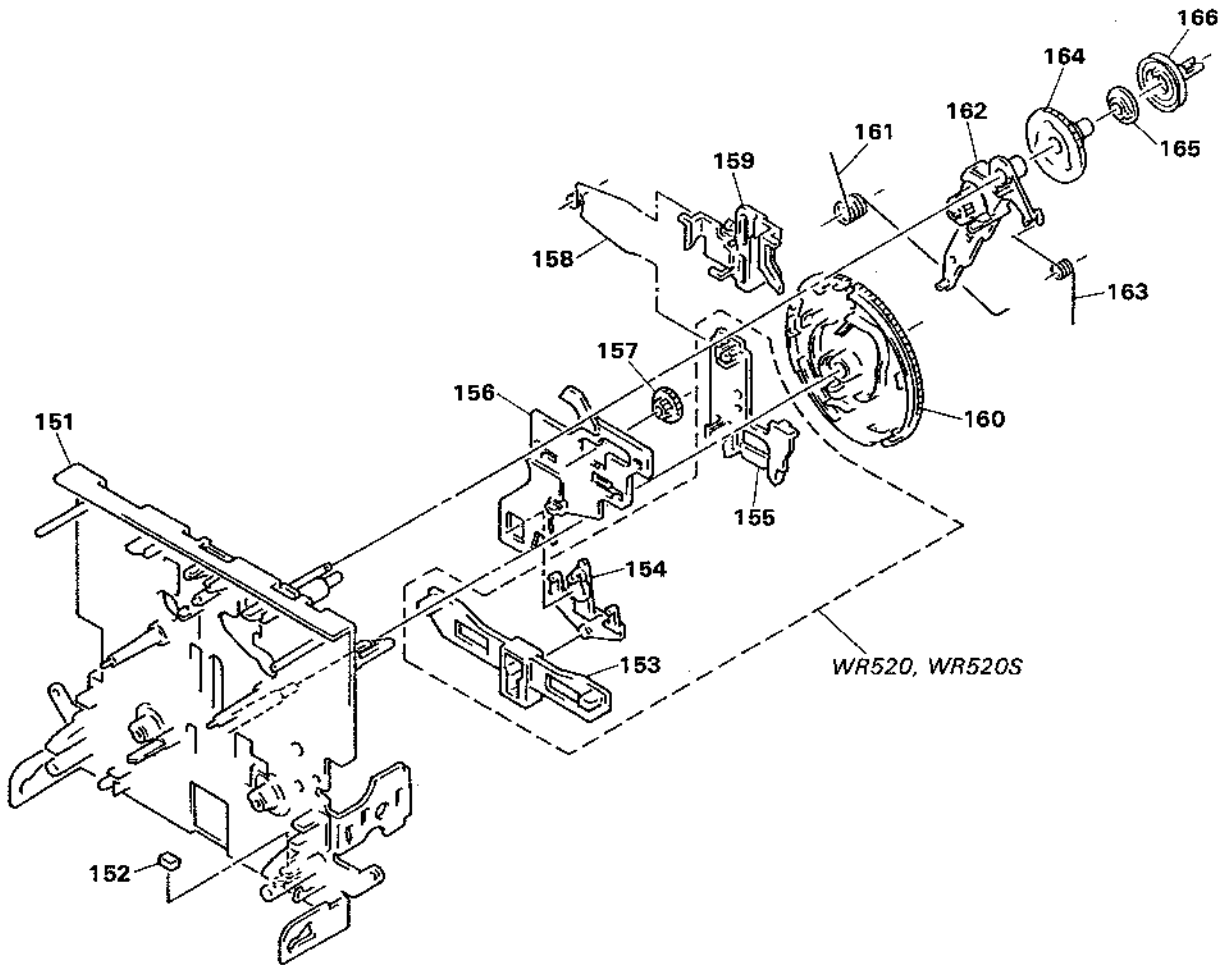

No.	Part No.	Description	Remarks	No.	Part No.	Description	Remarks
151	X-3359-415-1 X-3359-416-1	{520,520S}...CHASSIS ASSY, MECHANICAL {320,320S}...CHASSIS ASSY, MECHANICAL		158	3-359-454-01	SPRING, TORSION	
152	3-359-469-01	SPACER		159	3-359-429-01	SLIDER (BRAKE PLATE)	
153	*3-359-425-01	{520,520S}...SLIDER (REVERSE SLIDER)		160	3-359-420-01	GEAR (CAM GEAR)	
154	3-359-426-01	{520,520S}...LEVER (REVERSE LEVER)		161	3-359-456-01	SPRING (TRIGGER SPRING), TORSION	
155	*3-359-427-01	{520,520S}...SLIDER (LEVERSE SLIDER)		162	X-3359-405-1	LEVER (FR ARM) ASSY	
156	*3-359-415-01	SLIDER (TRIGGER SLIDER)		163	3-359-453-01	SPRING (FR ARM), TORSION	
157	3-359-448-01	GEAR (TRIGGER)		164	3-359-419-01	GEAR (FR GEAR)	
				165	3-359-421-01	CLUTCH (REEL DISK)	
				166	3-359-418-01	PULLEY (FR PULLEY)	

SECTION 6 ELECTRICAL PARTS LIST

NOTE:

- Due to standardization, replacements in the parts list may be different from the parts specified in the diagrams or the components used on the set.
- Items marked "★" are not stocked since they are seldom required for routine service. Some delay should be anticipated when ordering these items.
- If there are two or more same circuits in a set such as a stereophonic machine, only typical circuit parts may be indicated and capacitors and resistors in other same circuits may be omitted.

CAPACITORS:

MF: μF , PF: $\mu P F$.

RESISTORS

- All resistors are in ohms.
- F: nonflammable

COILS

- MMH: mH, UH: μH

SEMICONDUCTORS

In each case, U: μ , for example:
 UA...: μA ..., UPA...: $\mu P A$...,
 UPC...: $\mu P C$, UPD...: $\mu P D$...

The components identified by mark Δ or dotted line with mark Δ are critical for safety. Replace only with part number specified.

Les composants identifiés par une marque Δ sont critiques pour la sécurité. Ne les remplacer que par une pièce portant le numéro spécifié.

• WG: West Germany model

Ref.No.	Part No.	Description
901	*A-2006-250-A	{320}...MOUNTED PCB, AUDIO
	*A-2006-251-A	{520}...MOUNTED PCB, AUDIO
	*A-2006-301-A	{520S}...MOUNTED PCB, AUDIO
	*A-2006-302-A	{320S}...MOUNTED PCB, AUDIO
902	*1-634-840-11	(DECK A)...PC BOARD, MD (A)
	*1-634-843-11	(DECK B)...PC BOARD, MD (B)
903	*1-634-841-11	(DECK A)...PC BOARD, LEAF SW (A)
	*1-634-841-11	(DECK B)...PC BOARD, LEAF SW (B)
904	1-575-847-11	WIRE, FLAT TYPE (5 CORE)
905	1-575-779-11	WIRE, FLAT TYPE (5 CORE)
906	1-575-968-11	WIRE, FLAT TYPE (7 CORE)
907	1-575-781-11	WIRE, FLAT TYPE (9 CORE)
908	1-575-782-11	WIRE, FLAT TYPE (9 CORE)
909	1-575-784-11	WIRE, FLAT TYPE (13 CORE)
910	1-533-213-31	HOLDER, FUSE
911	Δ 1-569-007-11	(E)...ADAPTOR, CONVERSION 2P
912	Δ 1-551-188-XX	(E).....CORD, POWER
	Δ 1-551-506-XX	(US,Canadian)...CORD, POWER
	Δ 1-555-795-00	(AEP,WG).....CORD, POWER, EULO PLUG
	Δ 1-556-035-00	(UK).....CORD, POWER
913	1-548-596-31	COUNTER, TAPE (MIDDLE TYPE)
C11A	1-110-342-11	MYLAR 390PF 5% 50V
C11B	1-110-342-11	MYLAR 390PF 5% 50V
C12A	1-136-157-00	FILM 0.022MF 5% 50V
C12B	1-136-157-00	FILM 0.022MF 5% 50V
C13A	1-124-282-00	ELECT 22MF 20% 25V
C13B	1-124-282-00	ELECT 22MF 20% 25V
C14	1-136-273-91	FILM 75PF 5% 630V
C15	1-162-288-31	CERAMIC 330PF 10% 50V
C17	1-162-209-31	{520,520S}...CERAMIC 27PF 5% 50V
C17	1-162-288-31	{320,320S}...CERAMIC 330PF 10% 50V
C21A	1-110-342-11	MYLAR 390PF 5% 50V
C21B	1-110-342-11	MYLAR 390PF 5% 50V
C22A	1-136-157-00	FILM 0.022MF 5% 50V
C22B	1-136-157-00	FILM 0.022MF 5% 50V
C23A	1-124-282-00	ELECT 22MF 20% 25V
C23B	1-124-282-00	ELECT 22MF 20% 25V
C24	1-136-273-91	FILM 75PF 5% 630V
C25	1-162-288-31	CERAMIC 330PF 10% 50V
C27	1-162-209-31	{520,520S}...CERAMIC 27PF 5% 50V
C27	1-162-288-31	{320,320S}...CERAMIC 330PF 5% 50V
C31A	1-124-443-00	ELECT 100MF 20% 10V
C31B	1-124-443-00	ELECT 100MF 20% 10V

Ref.No.	Part No.	Description
C32A	1-124-443-00	ELECT 100MF 20% 10V
C32B	1-124-443-00	ELECT 100MF 20% 10V
C33	1-124-119-00	ELECT 330MF 20% 16V
C51	1-130-729-00	{520,520S}...FILM 0.0027MF 5% 100V
C51	1-136-593-11	{320,320S}...FILM 0.0033MF 5% 100V
C52	1-130-729-00	{520,520S}...FILM 0.0027MF 5% 100V
C52	1-136-593-11	{320,320S}...FILM 0.0033MF 5% 100V
C53	1-130-339-00	FILM 0.0056MF 5% 100V
C54	1-136-562-11	{520,520S}...FILM 0.0082MF 5% 630V
C54	1-136-601-11	{320,320S}...FILM 0.01MF 5% 630V
C55	1-161-494-00	CERAMIC 0.022MF 25V
C56	1-124-925-11	ELECT 2.2MF 20% 50V
C57	1-124-791-11	ELECT 1MF 20% 50V
C58	1-162-282-31	CERAMIC 100PF 10% 50V
C71A	1-123-875-11	ELECT 10MF 20% 50V
C71B	1-123-875-11	ELECT 10MF 20% 50V
C72A	1-123-875-11	ELECT 10MF 20% 50V
C72B	1-123-875-11	ELECT 10MF 20% 50V
C101	1-126-301-11	ELECT 1MF 20% 50V
C102	1-136-157-00	FILM 0.022MF 5% 50V
C103	1-162-294-31	CERAMIC 0.001MF 10% 50V
C104	1-126-059-11	ELECT 10MF 20% 50V
C105	1-130-475-00	MYLAR 0.0022MF 5% 50V
C106	1-130-475-00	MYLAR 0.0022MF 5% 50V
C107	1-136-174-00	FILM 0.56MF 5% 50V
C108	1-136-171-00	FILM 0.33MF 5% 50V
C109	1-126-059-11	ELECT 10MF 20% 50V
C110	1-124-994-11	ELECT 100MF 20% 10V
C111	1-126-059-11	ELECT 10MF 20% 50V
C112	1-126-162-11	ELECT 3.3MF 20% 50V
C113	1-126-300-11	ELECT 0.47MF 20% 50V
C114	1-126-162-11	ELECT 3.3MF 20% 50V
C201	1-126-301-11	ELECT 1MF 20% 50V
C202	1-136-157-00	FILM 0.022MF 5% 50V
C203	1-162-294-31	CERAMIC 0.001MF 10% 50V
C204	1-126-059-11	ELECT 10MF 20% 50V
C205	1-130-475-00	MYLAR 0.0022MF 5% 50V
C206	1-130-475-00	MYLAR 0.0022MF 5% 50V
C207	1-136-174-00	FILM 0.56MF 5% 50V
C208	1-136-171-00	FILM 0.33MF 5% 50V
C209	1-126-059-11	ELECT 10MF 20% 50V
C210	1-124-994-11	ELECT 100MF 20% 10V

Ref.No.	Part No.	Description			
C211	1-126-059-11	ELECT	10MF	20%	50V
C212	1-126-162-11	ELECT	3.3MF	20%	50V
C213	1-126-300-11	ELECT	0.47MF	20%	50V
C214	1-126-162-11	ELECT	3.3MF	20%	50V
C502	1-124-472-11	ELECT	470MF	20%	6.3V
C503	1-126-301-11	ELECT	1MF	20%	50V
C504	1-161-494-00	CERAMIC	0.022MF		25V
C505	1-126-161-11	ELECT	2.2MF	20%	50V
C506	1-126-059-11	(520,520S)...ELECT	10MF	20%	50V
C701	1-124-045-00	ELECT	4.7MF	20%	50V
C702	1-124-987-00	ELECT	3300MF	20%	16V
C703	1-124-887-00	ELECT	3300MF	20%	16V
C704	1-124-910-11	ELECT	47MF	20%	50V
C705	1-124-443-00	ELECT	100MF	20%	6.3V
C706	1-126-022-11	ELECT	47MF	20%	16V
C707	1-126-022-11	ELECT	47MF	20%	16V
C708	1-124-473-11	ELECT	1000MF	20%	10V
C709	1-124-473-11	ELECT	1000MF	20%	10V
C710	1-164-159-11	(320,320S)...CERAMIC	0.1MF		50V
C801	1-124-443-00	ELECT	100MF	20%	6.3V
C802	1-126-059-11	ELECT	10MF	20%	50V
C803	1-126-301-11	ELECT	1MF	20%	50V
C804	1-136-165-00	FILM	0.1MF	5%	50V
C805	1-136-165-00	FILM	0.1MF	5%	50V
C807	1-126-300-11	ELECT	0.47MF	20%	50V
C808	1-161-494-00	CERAMIC	0.022MF		25V
C901	1-161-494-00	CERAMIC	0.022MF		25V
CNP31A*	1-568-824-11	SOCKET, CONNECTOR	5P		
CNP31B*	1-568-824-11	SOCKET, CONNECTOR	5P		
CNP32A*	1-564-706-11	PIN, CONNECTOR (SMALL TYPE)	4P		
CNP32B*	1-564-709-11	PIN, CONNECTOR (SMALL TYPE)	7P		
CNP71A*	1-564-705-11	PIN, CONNECTOR (SMALL TYPE)	3P		
CNP71B*	1-564-705-11	PIN, CONNECTOR (SMALL TYPE)	3P		
CNP72A*	1-564-706-11	PIN, CONNECTOR (SMALL TYPE)	4P		
CNP72B*	1-564-706-11	PIN, CONNECTOR (SMALL TYPE)	4P		
CNP73A*	1-568-826-11	SOCKET, CONNECTOR	7P		
CNP73B*	1-568-832-11	SOCKET, CONNECTOR	13P		
CNP81A*	1-568-852-11	SOCKET, CONNECTOR	9P		
CNP81B*	1-568-852-11	SOCKET, CONNECTOR	9P		
CN501	*1-568-824-11	SOCKET, CONNECTOR	5P		
CN502	*1-568-824-11	SOCKET, CONNECTOR	5P		
CN504	*1-564-705-11	PIN, CONNECTOR (SMALL TYPE)	3P		
CN701	*1-564-506-11	PLUG, CONNECTOR	3P		
CN702	*1-564-337-00	PIN, CONNECTOR	3P		
CN801	*1-568-828-11	SOCKET, CONNECTOR	9P		
CN802	*1-568-828-11	SOCKET, CONNECTOR	9P		
CN803	*1-568-832-11	SOCKET, CONNECTOR	13P		
CN804	*1-568-826-11	SOCKET, CONNECTOR	7P		
CN805	*1-564-505-11	PLUG, CONNECTOR	2P		
D31	8-719-107-94	DIODE 1SS202-1			
D101	8-719-107-94	DIODE 1SS202-1			
D102	8-719-107-94	DIODE 1SS202-1			
D201	8-719-107-94	DIODE 1SS202-1			
D202	8-719-107-94	DIODE 1SS202-1			

Ref.No.	Part No.	Description
D301	8-719-301-44	DIODE SEL2410E-D (L-∞)
D302	8-719-301-44	DIODE SEL2410E-D (L-10)
D303	8-719-301-44	DIODE SEL2410E-D (L-6)
D304	8-719-301-44	DIODE SEL2410E-D (L-3)
D305	8-719-301-38	DIODE SEL2210S-C (L 0)
D306	8-719-301-38	DIODE SEL2210S-C (L+3)
D307	8-719-301-38	DIODE SEL2210S-C (L+6)
D401	8-719-301-44	DIODE SEL2410E-D (R-∞)
D402	8-719-301-44	DIODE SEL2410E-D (R-10)
D403	8-719-301-44	DIODE SEL2410E-D (R-6)
D404	8-719-301-44	DIODE SEL2410E-D (R-3)
D405	8-719-301-38	DIODE SEL2210S-C (R-0)
D406	8-719-301-38	DIODE SEL2210S-C (R+3)
D407	8-719-301-38	DIODE SEL2210S-C (R+6)
D501	8-719-107-94	DIODE 1SS202-1
D502	8-719-200-77	DIODE 10E2N
D503	8-719-001-33	DIODE UZL-11L1
D701	8-719-200-77	DIODE 10E2N
D702	8-719-200-77	DIODE 10E2N
D703	8-719-200-77	DIODE 10E2N
D704	8-719-200-77	DIODE 10E2N
D705	8-719-200-77	DIODE 10E2N
D706	8-719-200-77	DIODE 10E2N
D707	8-719-107-94	DIODE 1SS202-1
D708	8-719-000-78	DIODE UZL-7L2
D709	8-719-933-33	DIODE HZS6A1L
D710	8-719-933-33	DIODE HZS6A1L
D801	8-719-107-94	DIODE 1SS202-1
D802	8-719-107-94	DIODE 1SS202-1
D901	8-719-301-38	DIODE SEL2210S-C (REC)
D902	8-719-301-52	DIODE SEL2810A-C (PAUSE)
D903	8-719-301-44	DIODE SEL2410E-D (PLAY)
D904	8-719-301-52	(520,520S)...DIODE SEL2810A-C (B FWD)
D905	8-719-301-52	(520,520S)...DIODE SEL2810A-C (B REV)
D906	8-719-301-38	DIODE SEL2210S-C (HIGH)
D907	8-719-301-38	DIODE SEL2210S-C (NORM)
D908	8-719-301-44	DIODE SEL2410E-D (PLAY)
D909	8-719-301-52	(520,520S)...DIODE SEL2810A-C (A FWD)
D910	8-719-301-52	(520,520S)...DIODE SEL2810A-C (A REV)
F701	Δ 1-532-259-00	(E,AEP,WG,UK)...FUSE, TIME-LAG 1.6A
F701	Δ 1-532-742-11	(US,Canadian)...FUSE, GLASS TUBE 1.6A
F702	Δ 1-532-259-00	(E,AEP,WG,UK)...FUSE, TIME-LAG 1.6A
F702	Δ 1-532-742-11	(US,Canadian)...FUSE, GLASS TUBE 1.6A
HP901	1-543-536-11	(320,320S DECK A)...HEAD, MAGNETIC (PLAYBACK)
HE901	1-543-535-11	(320,320S DECK B)...HEAD, MAGNETIC (ERASE)
HP902	A-2003-418-A	(520,520S DECK A)...BASE ASSY, HEAD
HRP901	1-543-537-11	(320,320S DECK B)...HEAD, MAGNETIC (REC/PB)
HRP902	A-2003-477-A	(520,520S DECK B)...BASE ASSY, HEAD (REC/PB/ERASE)
HE902		
IC31A	8-759-111-44	IC UPC4570C-1
IC31B	8-759-111-44	IC UPC4570C-1
IC81A	8-719-939-23	PHOTO SENSOR GP2S09-C
IC81B	8-719-939-23	PHOTO SENSOR GP2S09-C
IC501	8-752-036-34	IC CXA1330S

Note:
The components identified by mark Δ or dotted line with mark Δ are critical for safety. Replace only with part number specified.

Note:
Les composants identifiés par une marque Δ sont critiques pour la sécurité. Ne les remplacer que par une pièce portant le numéro spécifié.

Ref.No.	Part No.	Description
IC502	8-752-033-61	(320,320S)...IC CXA1198AP
IC502	8-752-039-24	(520,520S)...IC CXA1398P
IC503	8-759-208-06	(320,320S)...IC TC4051BPHS
IC504	8-759-040-53	IC MC14053BCP
IC505	8-759-945-58	IC RC4558P
IC506	8-759-945-58	IC RC4558P
IC507	8-759-634-51	IC M5218AP
IC701	8-759-945-58	IC RC4558P
IC801	8-759-634-59	IC M50964-224SP
IC802	8-759-207-05	IC TA7272P
IC901	8-741-100-48	IC SBX1610-59
J501	1-565-258-11	JACK, PIN 4P (LINE IN/OUT)
J502	1-507-796-71	JACK (PHONES)
L11	1-410-780-11	INDUCTOR 27MMH
L21	1-410-780-11	INDUCTOR 27MMH
LPF101	1-236-087-11	FILTER, LOW PASS
LPF201	1-236-087-11	FILTER, LOW PASS
M901	X-3359-417-1	MOTOR ASSY
M902	A-2003-474-A	MOTOR (REEL MOTOR) ASSY
Q51	8-729-142-46	TRANSISTOR 2SC2001-LK
Q52	8-729-142-46	TRANSISTOR 2SC2001-LK
Q53	8-729-111-29	TRANSISTOR 2SD1616A-K
Q71A	8-729-820-16	TRANSISTOR 2SA1317-S
Q71B	8-729-820-16	TRANSISTOR 2SA1317-S
Q101	8-729-620-05	TRANSISTOR 2SC2603-EF
Q102	8-729-900-74	TRANSISTOR DTC143TS
Q103	8-729-620-05	(320,320S)...TRANSISTOR 2SC2603-EF
Q201	8-729-620-05	TRANSISTOR 2SC2603-EF
Q202	8-729-900-74	TRANSISTOR DTC143TS
Q203	8-729-620-05	(320,320S)...TRANSISTOR 2SC2603-EF
Q501	8-729-900-61	TRANSISTOR DTA114ES
Q502	8-729-900-61	TRANSISTOR DTA114ES
Q503	8-729-900-61	(320,320S)...TRANSISTOR DTA114ES
Q505	8-729-821-04	TRANSISTOR 2SA1317-STU
Q506	8-729-900-61	TRANSISTOR DTA114ES
Q507	8-729-900-61	TRANSISTOR DTA114ES
Q508	8-729-821-04	TRANSISTOR 2SA1317-STU
Q509	8-729-900-61	TRANSISTOR DTA114ES
Q510	8-729-821-04	TRANSISTOR 2SA1317-STU
Q511	8-729-821-04	TRANSISTOR 2SA1317-STU
Q701	8-729-620-05	TRANSISTOR 2SC2603-EF
Q702	8-729-920-98	TRANSISTOR 2SD1761-EF
Q703	8-729-900-89	TRANSISTOR DTC144ES
Q704	8-729-900-85	TRANSISTOR DTC144WS
Q705	8-729-920-97	TRANSISTOR 2SB1187-EF
Q706	8-729-920-98	TRANSISTOR 2SD1761-EF
Q801	8-729-900-80	TRANSISTOR DTC114ES
Q802	8-729-821-04	TRANSISTOR 2SA1317-STU
Q803	8-729-900-61	TRANSISTOR DTA114ES
Q804	8-729-821-04	TRANSISTOR 2SA1317-STU
Q805	8-729-620-05	TRANSISTOR 2SC2603-EF
Q806	8-729-620-05	TRANSISTOR 2SC2603-EF
Q807	8-729-620-05	TRANSISTOR 2SC2603-EF
Q808	8-729-620-05	TRANSISTOR 2SC2603-EF
Q809	8-729-620-05	TRANSISTOR 2SC2603-EF
Q810	8-729-620-05	TRANSISTOR 2SC2603-EF
Q811	8-729-620-05	TRANSISTOR 2SC2603-EF

Ref.No.	Part No.	Description				
Q812	8-729-620-05	TRANSISTOR 2SC2603-EF				
Q813	8-729-620-05	TRANSISTOR 2SC2603-EF				
Q814	8-729-620-05	TRANSISTOR 2SC2603-EF				
Q815	8-729-821-04	TRANSISTOR 2SA1317-STU				
Q816	8-729-900-61	TRANSISTOR DTA114ES				
Q817	8-729-801-84	TRANSISTOR 2SB1013-4				
Q818	8-729-900-89	TRANSISTOR DTC144ES				
Q819	8-729-801-84	TRANSISTOR 2SB1013-4				
Q820	8-729-900-61	TRANSISTOR DTA114ES				
R11A	1-247-881-00	CARBON	120K	5%	1/4W	
R11B	1-247-881-00	CARBON	120K	5%	1/4W	
R12A	1-249-405-11	CARBON	100	5%	1/4W	
R12B	1-249-405-11	CARBON	100	5%	1/4W	
R13A	1-247-882-11	CARBON	130K	5%	1/4W	
R13B	1-247-882-11	CARBON	130K	5%	1/4W	
R14A	1-249-426-11	CARBON	5.6K	5%	1/4W	
R14B	1-249-426-11	CARBON	5.6K	5%	1/4W	
R15	1-249-430-11	CARBON	12K	5%	1/4W	
R21A	1-247-881-00	CARBON	120K	5%	1/4W	
R21B	1-247-881-00	CARBON	120K	5%	1/4W	
R22A	1-249-405-11	CARBON	100	5%	1/4W	
R22B	1-249-405-11	CARBON	100	5%	1/4W	
R23A	1-247-882-11	CARBON	130K	5%	1/4W	
R23B	1-247-882-11	CARBON	130K	5%	1/4W	
R24A	1-249-426-11	CARBON	5.6K	5%	1/4W	
R24B	1-249-426-11	CARBON	5.6K	5%	1/4W	
R25	1-249-430-11	CARBON	12K	5%	1/4W	
R31A	1-249-409-11	CARBON	220	5%	1/4W	
R31B	1-249-409-11	CARBON	220	5%	1/4W	
R32A	1-249-409-11	CARBON	220	5%	1/4W	
R32B	1-249-409-11	CARBON	220	5%	1/4W	
R51	1-249-435-11	CARBON	33K	5%	1/4W	
R52	1-249-435-11	CARBON	33K	5%	1/4W	
R53	1-249-429-11	CARBON	10K	5%	1/4W	
R54	▲.1-212-849-00	(520,520S)...FUSIBLE	4.7	5%	1/4W F	
R54	▲.1-212-851-00	(320,320S)...FUSIBLE	5.6	5%	1/4W F	
R71A	1-249-433-11	CARBON	22K	5%	1/4W	
R71B	1-249-433-11	CARBON	22K	5%	1/4W	
R72A	1-249-433-11	CARBON	22K	5%	1/4W	
R72B	1-249-433-11	CARBON	22K	5%	1/4W	
R73A	1-249-437-11	CARBON	47K	5%	1/4W	
R73B	1-249-437-11	CARBON	47K	5%	1/4W	
R74A	1-249-437-11	CARBON	47K	5%	1/4W	
R74B	1-249-437-11	CARBON	47K	5%	1/4W	
R81	1-249-414-11	CARBON	560	5%	1/4W	
R82	1-247-818-11	(520,520S)...CARBON	300	5%	1/4W	
R83	1-247-834-11	CARBON	1.3K	5%	1/4W	
R84A	1-249-417-11	CARBON	1K	5%	1/4W	
R84B	1-249-417-11	CARBON	1K	5%	1/4W	
R85A	1-249-408-11	CARBON	180	5%	1/4W	
R85B	1-249-408-11	CARBON	180	5%	1/4W	

<p>Note: The components identified by mark ▲ or dotted line with mark ▲ are critical for safety. Replace only with part number specified.</p>	<p>Note: Les composants identifiés par une marque ▲ sont critiques pour la sécurité. Ne les remplacer que par une pièce portant le numéro spécifié.</p>
--	--

TC-W320/W320S/WR520/WR520S

Ref.No.	Part No.	Description			
R101	1-249-417-11	CARBON	1K	5%	1/4W
R102	1-249-433-11	CARBON	22K	5%	1/4W
R103	1-249-429-11	CARBON	10K	5%	1/4W
R104	1-249-421-11	CARBON	2.2K	5%	1/4W
R105	1-249-421-11	CARBON	2.2K	5%	1/4W
R106	1-249-421-11	CARBON	2.2K	5%	1/4W
R107	1-247-887-00	CARBON	220K	5%	1/4W
R108	1-249-423-11	CARBON	3.3K	5%	1/4W
R109	1-249-423-11	CARBON	3.3K	5%	1/4W
R110	1-249-428-11	CARBON	8.2K	5%	1/4W
R111	1-247-864-11	CARBON	24K	5%	1/4W
R112	1-249-414-11	CARBON	560	5%	1/4W
R113	1-249-417-11	(320,320S)...CARBON	1K	5%	1/4W
R114	1-249-429-11	(320,320S)...CARBON	10K	5%	1/4W
R115	1-249-421-11	(320,320S)...CARBON	2.2K	5%	1/4W
R115	1-249-426-11	(520,520S)...CARBON	5.6K	5%	1/4W
R116	1-249-428-11	(320,320S)...CARBON	8.2K	5%	1/4W
R117	1-249-431-11	(320,320S)...CARBON	15K	5%	1/4W
R117	1-249-429-11	(520,520S)...CARBON	10K	5%	1/4W
R118	1-249-429-11	CARBON	10K	5%	1/4W
R119	1-249-435-11	CARBON	33K	5%	1/4W
R120	1-249-433-11	CARBON	22K	5%	1/4W
R121	1-249-408-11	CARBON	180	5%	1/4W
R122	1-249-421-11	CARBON	2.2K	5%	1/4W
R123	1-249-429-11	CARBON	10K	5%	1/4W
R124	1-249-428-11	CARBON	8.2K	5%	1/4W
R125	1-249-427-11	CARBON	6.8K	5%	1/4W
R126	1-249-409-11	CARBON	220	5%	1/4W
R127	1-249-417-11	CARBON	1K	5%	1/4W
R201	1-249-417-11	CARBON	1K	5%	1/4W
R202	1-249-433-11	CARBON	22K	5%	1/4W
R203	1-249-429-11	CARBON	10K	5%	1/4W
R204	1-249-421-11	CARBON	2.2K	5%	1/4W
R205	1-249-421-11	CARBON	2.2K	5%	1/4W
R206	1-249-421-11	CARBON	2.2K	5%	1/4W
R207	1-247-887-00	CARBON	220K	5%	1/4W
R208	1-249-423-11	CARBON	3.3K	5%	1/4W
R209	1-249-423-11	CARBON	3.3K	5%	1/4W
R210	1-249-428-11	CARBON	8.2K	5%	1/4W
R211	1-247-864-11	CARBON	24K	5%	1/4W
R212	1-249-414-11	CARBON	560	5%	1/4W
R213	1-249-417-11	(320,320S)...CARBON	1K	5%	1/4W
R214	1-249-429-11	(320,320S)...CARBON	10K	5%	1/4W
R215	1-249-421-11	(320,320S)...CARBON	2.2K	5%	1/4W
R215	1-249-426-11	(520,520S)...CARBON	5.6K	5%	1/4W
R216	1-249-428-11	(320,320S)...CARBON	8.2K	5%	1/4W
R217	1-249-431-11	(320,320S)...CARBON	15K	5%	1/4W
R217	1-249-429-11	(520,520S)...CARBON	10K	5%	1/4W
R218	1-249-429-11	CARBON	10K	5%	1/4W
R219	1-249-435-11	CARBON	33K	5%	1/4W
R220	1-249-433-11	CARBON	22K	5%	1/4W
R221	1-249-408-11	CARBON	180	5%	1/4W
R222	1-249-421-11	CARBON	2.2K	5%	1/4W
R223	1-249-429-11	CARBON	10K	5%	1/4W

Ref.No.	Part No.	Description			
R224	1-249-428-11	CARBON	8.2K	5%	1/4W
R225	1-249-427-11	CARBON	6.8K	5%	1/4W
R226	1-249-409-11	CARBON	220	5%	1/4W
R227	1-249-417-11	CARBON	1K	5%	1/4W
R501	1-249-417-11	CARBON	1K	5%	1/4W
R502	1-249-434-11	CARBON	27K	5%	1/4W
R503	1-249-429-11	CARBON	10K	5%	1/4W
R504	1-247-864-11	CARBON	24K	5%	1/4W
R506	1-249-441-11	CARBON	100K	5%	1/4W
R507	1-249-417-11	CARBON	1K	5%	1/4W
R508	1-249-441-11	CARBON	100K	5%	1/4W
R509	1-249-427-11	CARBON	6.8K	5%	1/4W
R510	1-249-413-11	CARBON	470	5%	1/4W
R511	1-249-429-11	CARBON	10K	5%	1/4W
R512	1-249-413-11	CARBON	470	5%	1/4W
R513	1-247-870-11	CARBON	43K	5%	1/4W
R514	1-249-429-11	CARBON	10K	5%	1/4W
R515	1-249-429-11	CARBON	10K	5%	1/4W
R516	1-249-429-11	CARBON	10K	5%	1/4W
R517	1-249-433-11	CARBON	22K	5%	1/4W
R518	1-249-433-11	CARBON	22K	5%	1/4W
R519	1-249-427-11	(320,320S)...CARBON	6.8K	5%	1/4W
R519	1-249-418-11	(520,520S)...CARBON	1.2K	5%	1/4W
R520	1-249-433-11	CARBON	22K	5%	1/4W
R521	1-249-431-11	(320,320S)...CARBON	15K	5%	1/4W
R521	1-249-428-11	(520,520S)...CARBON	9.1K	5%	1/4W
R522	1-249-433-11	CARBON	22K	5%	1/4W
R523	1-247-858-11	CARBON	13K	5%	1/4W
R524	1-249-429-11	(520,520S)...CARBON	10K	5%	1/4W
R525	1-249-442-11	CARBON	510	5%	1/4W
R526	1-249-431-11	CARBON	15K	5%	1/4W
R527	1-249-405-11	CARBON	100	5%	1/4W
R528	1-249-405-11	CARBON	100	5%	1/4W
R601	1-249-438-11	(320,320S)...CARBON	56K	5%	1/4W
R602	1-249-440-11	(320,320S)...CARBON	82K	5%	1/4W
R603	1-247-882-11	(320,320S)...CARBON	130K	5%	1/4W
R604	1-249-439-11	(320,320S)...CARBON	68K	5%	1/4W
R605	1-249-435-11	(320,320S)...CARBON	33K	5%	1/4W
R606	1-247-872-11	(320,320S)...CARBON	51K	5%	1/4W
R611	1-247-883-00	(320,320S)...CARBON	150K	5%	1/4W
R612	1-247-878-00	(320,320S)...CARBON	91K	5%	1/4W
R613	1-247-881-00	(320,320S)...CARBON	120K	5%	1/4W
R614	1-247-876-11	(320,320S)...CARBON	75K	5%	1/4W
R615	1-249-437-11	(320,320S)...CARBON	47K	5%	1/4W
R616	1-249-439-11	(320,320S)...CARBON	68K	5%	1/4W
R621	1-247-887-00	(320,320S)...CARBON	220K	5%	1/4W
R622	1-247-881-00	(320,320S)...CARBON	120K	5%	1/4W
R623	1-249-440-11	(320,320S)...CARBON	82K	5%	1/4W
R624	1-249-436-11	(320,320S)...CARBON	39K	5%	1/4W
R625	1-247-872-11	(320,320S)...CARBON	51K	5%	1/4W
R626	1-249-439-11	(320,320S)...CARBON	68K	5%	1/4W
R641	1-249-441-11	(320,320S)...CARBON	100K	5%	1/4W
R642	1-249-437-11	(320,320S)...CARBON	47K	5%	1/4W
R643	1-249-439-11	(320,320S)...CARBON	68K	5%	1/4W
R644	1-247-870-11	(320,320S)...CARBON	43K	5%	1/4W

Ref.No.	Part No.	Description							
R645	1-247-868-11	{320,320S}...CARBON	36K	5%	1/4W				
R646	1-249-433-11	{320,320S}...CARBON	22K	5%	1/4W				
R661	1-247-881-00	{320,320S}...CARBON	120K	5%	1/4W				
R662	1-249-437-11	{320,320S}...CARBON	47K	5%	1/4W				
R663	1-249-438-11	{320,320S}...CARBON	56K	5%	1/4W				
R664	1-249-439-11	{320,320S}...CARBON	68K	5%	1/4W				
R665	1-247-872-11	{320,320S}...CARBON	51K	5%	1/4W				
R666	1-247-868-11	{320,320S}...CARBON	36K	5%	1/4W				
R681	1-247-880-11	{320,320S}...CARBON	110K	5%	1/4W				
R682	1-247-876-11	{320,320S}...CARBON	75K	5%	1/4W				
R683	1-249-436-11	{320,320S}...CARBON	39K	5%	1/4W				
R684	1-249-434-11	{320,320S}...CARBON	27K	5%	1/4W				
R685	1-249-438-11	{320,320S}...CARBON	56K	5%	1/4W				
R686	1-247-870-11	{320,320S}...CARBON	43K	5%	1/4W				
R701	1-247-752-11	CARBON	1K	5%	1/2W				
R702	1-249-425-11	CARBON	4.7K	5%	1/4W				
R703	1-249-437-11	CARBON	47K	5%	1/4W				
R704	1-249-437-11	CARBON	47K	5%	1/4W				
R705	1-249-425-11	CARBON	4.7K	5%	1/4W				
R706	1-249-425-11	CARBON	4.7K	5%	1/4W				
R707	1-249-427-11	CARBON	6.8K	5%	1/4W				
R708	1-249-419-11	CARBON	1.5K	5%	1/4W				
R709	1-249-425-11	CARBON	4.7K	5%	1/4W				
R710	1-249-419-11	CARBON	1.5K	5%	1/4W				
R711	1-249-429-11	CARBON	10K	5%	1/4W				
R712	1-249-417-11	CARBON	1K	5%	1/4W				
R713	1-249-427-11	CARBON	6.8K	5%	1/4W				
R714	1-249-427-11	CARBON	6.8K	5%	1/4W				
R801	1-249-412-11	{520,520S}...CARBON	390	5%	1/4W				
R802	1-249-412-11	{520,520S}...CARBON	390	5%	1/4W				
R803	1-249-410-11	CARBON	270	5%	1/4W				
R804	1-249-412-11	CARBON	390	5%	1/4W				
R805	1-249-413-11	CARBON	470	5%	1/4W				
R806	1-249-429-11	CARBON	10K	5%	1/4W				
R807	1-249-421-11	CARBON	2.2K	5%	1/4W				
R808	1-249-421-11	CARBON	2.2K	5%	1/4W				
R809	1-247-903-00	CARBON	1M	5%	1/4W				
R810	1-249-429-11	CARBON	10K	5%	1/4W				
R811	1-249-422-11	CARBON	2.7K	5%	1/4W				
R812	1-249-422-11	CARBON	2.7K	5%	1/4W				
R813	1-249-422-11	CARBON	2.7K	5%	1/4W				
R814	1-249-428-11	CARBON	8.2K	5%	1/4W				
R815	1-249-421-11	CARBON	2.2K	5%	1/4W				
R816	1-249-429-11	CARBON	10K	5%	1/4W				
R817	1-249-429-11	CARBON	10K	5%	1/4W				
R818	1-249-425-11	CARBON	4.7K	5%	1/4W				
R819	1-249-434-11	CARBON	27K	5%	1/4W				
R820	1-249-429-11	CARBON	10K	5%	1/4W				
R821	1-249-434-11	CARBON	27K	5%	1/4W				
R822	1-249-429-11	CARBON	10K	5%	1/4W				
R823	1-247-895-00	CARBON	470K	5%	1/4W				
R824	1-247-895-00	CARBON	470K	5%	1/4W				
R825	1-249-425-11	CARBON	4.7K	5%	1/4W				
R826	1-249-425-11	CARBON	4.7K	5%	1/4W				
R827	1-249-409-11	CARBON	220	5%	1/4W				
R828	1-249-409-11	CARBON	220	5%	1/4W				
R829	1-249-409-11	CARBON	220	5%	1/4W				
R830	1-249-407-11	CARBON	150	5%	1/4W				
R831	1-249-407-11	CARBON	150	5%	1/4W				
R832	1-249-407-11	CARBON	150	5%	1/4W				
R833	1-249-435-11	CARBON	33K	5%	1/4W				
R834	1-249-413-11	CARBON	470	5%	1/4W				
R835	1-249-413-11	CARBON	470	5%	1/4W				
R836	1-249-429-11	CARBON	10K	5%	1/4W				
R837	1-249-410-11	CARBON	270	5%	1/4W				
R838	1-249-412-11	{520,520S}...CARBON	390	5%	1/4W				
R839	1-249-412-11	{520,520S}...CARBON	390	5%	1/4W				
R840	1-249-441-11	{520,520S}...CARBON	100K	5%	1/4W				
R841	1-249-415-11	CARBON	680	5%	1/4W				
R842	1-249-429-11	CARBON	10K	5%	1/4W				
R843	1-249-437-11	CARBON	47K	5%	1/4W				
R844	1-247-866-11	CARBON	30K	5%	1/4W				
R845	1-249-434-11	CARBON	27K	5%	1/4W				
R846	1-249-425-11	CARBON	4.7K	5%	1/4W				
R847	1-247-862-11	CARBON	20K	5%	1/4W				
R848	1-247-872-11	CARBON	51K	5%	1/4W				
R850	1-247-872-11	CARBON	51K	5%	1/4W				
R851	1-249-405-11	CARBON	100	5%	1/4W				
R853	1-249-437-11	CARBON	47K	5%	1/4W				
R854	1-247-866-11	CARBON	30K	5%	1/4W				
R855	1-249-434-11	CARBON	27K	5%	1/4W				
R856	1-249-425-11	CARBON	4.7K	5%	1/4W				
R857	1-247-862-11	CARBON	20K	5%	1/4W				
R858	1-247-872-11	CARBON	51K	5%	1/4W				
R860	1-247-872-11	CARBON	51K	5%	1/4W				
R861	1-249-405-11	CARBON	100	5%	1/4W				
R862	1-249-429-11	CARBON	10K	5%	1/4W				
R881	1-249-415-11	CARBON	680	5%	1/4W				
R882	1-249-429-11	CARBON	10K	5%	1/4W				
R901	1-249-407-11	CARBON	150	5%	1/4W				
R902	1-249-409-11	CARBON	220	5%	1/4W				
R903	1-249-411-11	CARBON	330	5%	1/4W				
R904	1-249-413-11	CARBON	470	5%	1/4W				
R905	1-249-415-11	CARBON	680	5%	1/4W				
R906	1-249-417-11	CARBON	1K	5%	1/4W				
R907	1-249-420-11	CARBON	1.8K	5%	1/4W				
R908	1-249-407-11	CARBON	150	5%	1/4W				
R909	1-249-409-11	CARBON	220	5%	1/4W				
R910	1-249-411-11	CARBON	330	5%	1/4W				
R911	1-249-413-11	CARBON	470	5%	1/4W				
R912	1-249-415-11	CARBON	680	5%	1/4W				
R913	1-249-417-11	CARBON	1K	5%	1/4W				
R914	1-249-426-11	{520,520S}...CARBON	5.6K	5%	1/4W				
R915	1-249-430-11	{520,520S}...CARBON	12K	5%	1/4W				
R916	1-249-411-11	CARBON	330	5%	1/4W				
R917	1-249-411-11	CARBON	330	5%	1/4W				
RV12	1-230-498-11	{320,320S}...RES, ADJ, CARBON	47K						
RV12	1-230-500-11	{520,520S}...RES, ADJ, CARBON	220K						
RV11A	1-238-597-11	RES, ADJ, CARBON	1K						
RV11B	1-238-597-11	RES, ADJ, CARBON	1K						
RV21A	1-238-597-11	RES, ADJ, CARBON	1K						
RV21B	1-238-597-11	RES, ADJ, CARBON	1K						

TC-W320/W320S/WR520/WR520S



Ref.No.	Part No.	Description
RV22	1-230-500-11	(520,520S)...RES, ADJ, CARBON 220K
RV22	1-230-498-11	(320,320S)...RES, ADJ, CARBON 47K
RV71A	1-238-600-11	RES, ADJ, CARBON 10K
RV71B	1-238-600-11	RES, ADJ, CARBON 10K
RV72A	1-238-600-11	RES, ADJ, CARBON 10K
RV72B	1-238-600-11	RES, ADJ, CARBON 10K
RV101	1-238-016-11	RES, ADJ, CARBON 10K
RV201	1-238-016-11	RES, ADJ, CARBON 10K
RV501	1-241-058-11	RES, VAR, CARBON 50K/50K (REC LEVEL)
RV502	1-241-057-11	RES, VAR, CARBON 50K/50K (BALANCE)
RY31	1-515-726-11	RELAY
S81A	1-571-958-11	SWITCH, PUSH (1 KEY)(STOP)
S81	1-571-958-11	SWITCH, PUSH (1 KEY)(STOP)
S82A	1-571-281-21	SWITCH, LEAF (70EQ)
S82	1-571-281-21	SWITCH, LEAF (70EQ)
S83	1-571-281-21	SWITCH, LEAF (METEL)
S84	1-571-281-21	SWITCH, LEAF (REC A)
S85	1-571-281-21	(520,520S)...SWITCH, LEAF (REC B)
S86A	1-571-281-21	SWITCH, LEAF (HALF)
S86B	1-571-281-21	SWITCH, LEAF (HALF)
S701	1-571-305-11	SWITCH, PUSH (1 KEY)(POWER)
S901	1-572-358-11	SWITCH, SLIDE (DOLBY NR)
S902	1-572-358-11	(520,520S)...SWITCH, SLIDE (DIR-MODE)
S903	1-554-596-21	SWITCH, KEY BOARD (A STOP)
S904	1-554-596-21	SWITCH, KEY BOARD (A FWD)
S905	1-554-596-21	(520,520S)...SWITCH, KEY BOARD (A REV)
S906	1-554-596-21	SWITCH, KEY BOARD (B REW)
S907	1-554-596-21	SWITCH, KEY BOARD (B FF)
S908	1-554-596-21	SWITCH, KEY BOARD (B REC)
S909	1-554-596-21	SWITCH, KEY BOARD (DUBBING HIGH)
S910	1-554-596-21	SWITCH, KEY BOARD (DUBBING NORM)
S911	1-554-596-21	SWITCH, KEY BOARD (B STOP)
S912	1-554-596-21	SWITCH, KEY BOARD (B PAUSE)
S913	1-554-596-21	SWITCH, KEY BOARD (B FWD)
S914	1-554-596-21	(520,520S)...SWITCH, KEY BOARD (B REV)
S915	1-554-596-21	SWITCH, KEY BOARD (B REC MUTE)
S916	1-554-596-21	SWITCH, KEY BOARD (A REW)
S917	1-554-596-21	SWITCH, KEY BOARD (A FF)
T51	1-433-337-11	(520,520S)...TRANSFORMER, BIAS OSCILLATION
T51	1-433-338-12	(320,320S)...TRANSFORMER, BIAS OSCILLATION

Ref.No.	Part No.	Description
T701	△.1-449-661-21	(AEP,WG,UK)...TRANSFORMER, POWER
T701	△.1-449-666-21	(E).....TRANSFORMER, POWER
T701	△.1-449-420-21	(US,Canadian)...TRANSFORMER, POWER
VS901	△.1-570-307-11	(E)...SWITCH, VOLTAGE CHANGE (VOLTAGE)
X801	1-577-358-21	VIBRATOR, CERAMIC (4MHz)

ACCESSORY & PACKING MATERIAL

1-559-533-11	CORD, CONNECTION
*3-350-829-31	(520)...INDIVIDUAL CARTON
*3-350-829-41	(320)...INDIVIDUAL CARTON
*3-350-829-51	(520S)...INDIVIDUAL CARTON
*3-350-829-61	(320S)...INDIVIDUAL CARTON
*3-354-917-01	CUSHION
3-703-450-01	(US)...INSTRUCTION
3-751-499-11	(Canadian,E,AEP,UK)...MANUAL, INSTRUCTION (English,French,Spanish,Portuguese)
3-751-499-21	(US)...MANUAL, INSTRUCTION (English)
3-751-499-41	(AEP)...MANUAL, INSTRUCTION (German,Dutch,Swedish,Italian)
3-751-499-51	(WG)...MANUAL, INSTRUCTION (German)

Note:

The components identified by mark  or dotted line with mark  are critical for safety. Replace only with part number specified.

Note:

Les composants identifiés par une marque  sont critiques pour la sécurité. Ne les remplacer que par une pièce portant le numéro spécifié.