

TC-WR87ES/WR775

SERVICE MANUAL

US Model
Canadian Model

TC-WR775

US Model

TC-WR87ES

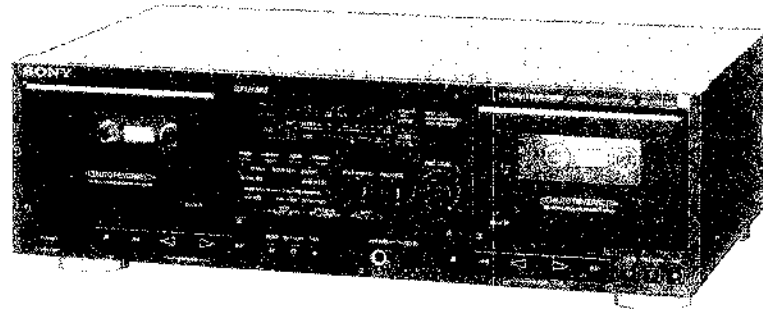

Photo: TC-WR87ES

SPECIFICATIONS

Recording system 4-track 2-channel stereo
Fast winding time Approx. 90 sec. (with Sony C-60 cassette)
Bias AC bias
Signal-to-noise ratio (at peak level)

Cassette	Dolby NR switch		
	OFF	B-Type ON	C-Type ON
Type IV (Sony METAL-SLT)	58 dB (WR775) 59 dB (WR87ES)	66 dB (WR775) 67 dB (WR87ES)	73 dB (WR775) 74 dB (WR87ES)
Type II (Sony UX-S)	57 dB (WR775) 58 dB (WR87ES)	65 dB (WR775) 66 dB (WR87ES)	72 dB (WR775) 73 dB (WR87ES)
Type I (Sony HF-S)	55 dB (WR775) 56 dB (WR87ES)	63 dB (WR775) 64 dB (WR87ES)	70 dB (WR775) 71 dB (WR87ES)

Total harmonic distortion 1.0% (with Sony METAL-SLT cassettes)

Frequency response (DOLBY NR OFF)

Type IV cassette (Sony METAL-SLT)	30 - 18,000 Hz (± 3 dB, IEC) 30 - 15,000 Hz (± 3 dB 0VU (-4 dB) recording)
Type II cassette (Sony UX-S)	30 - 17,000 Hz (± 3 dB, IEC)
Type I cassette (Sony HF-S)	30 - 15,000 Hz (± 3 dB, IEC)

Wow and flutter $\pm 0.13\%$ W.Peak (IEC)
0.07% WRMS (NAB)
 $\pm 0.18\%$ W.Peak (DIN)

Inputs

Line inputs (phono jacks)	Sensitivity	77.5 mV
	Input impedance	47 k ohms

Model Name Using Similar Mechanism	TC-WR775	TC-WR720/WR720A	
	TC-WR87ES	TC-WR80ES/WR820A	
Tape Transport Mechanism Type	TC-WR775	DECK A, B	TCM-190RB12
	TC-WR87ES	DECK A, B	TCM-190RB31

Outputs

Line outputs (phono jacks)	Rated output level	0.32 V at a load impedance of 47 k ohms
	Load impedance	Over 10 k ohms
Headphones (stereo phone jack)	Output level	0.2 mW at a load impedance of 32 ohms (WR775) 0.125 mW at a load impedance of 32 ohms (WR87ES)

General

Power requirements 120 V AC, 60 Hz
Power consumption 30 W
Dimensions Approx. 430 x 135 x 300 mm (width)
(17 x 5 1/4 x 11 7/8 inches)
including projecting parts and controls
Weight Approx. 4.9 kg (10 lbs 13 oz) (WR775)
Approx. 5.3 kg (11 lbs 11 oz) (WR87ES)

Supplied accessory Audio connecting cords (2)

Design and specifications subject to change without notice.

WR775 : TC-WR775
WR87ES : TC-WR87ES

* Dolby noise reduction and HX Pro headroom extension manufactured under license from Dolby Laboratories Licensing Corporation. HX Pro originated by Bang & Olufsen.

"DOLBY", the double-D symbol  and "HX PRO" are trademarks of Dolby Laboratories Licensing Corporation.

STEREO CASSETTE DECK
SONY[®]





TABLE OF CONTENTS

<u>Section</u>	<u>Title</u>	<u>Page</u>
SECTION 1.	GENERAL	3
SECTION 2.	DISASSEMBLY	4
SECTION 3.	MECHANICAL ADJUSTMENTS	7
SECTION 4.	ELECTRICAL ADJUSTMENTS	7
SECTION 5.	DIAGRAMS	
	5-1. Circuit Boards Location	11
	5-2. Semiconductor Lead Layouts	12
	5-3. Printed Wiring Boards	14
	5-4. Schematic Diagram —Audio/Power Section—	19
	5-5. Schematic Diagram —System Control/FL/Panel Section—	23
	5-6. Schematic Diagram —Panel Section—	27
SECTION 6.	EXPLODED VIEWS	
	6-1. Chassis Section	30
	6-2. Front Panel Section(TC-WR775)	31
	6-3. Front Panel Section(TC-WR87ES)	32
	6-4. Mechanism Section-1	33
	6-4. Mechanism Section-2	34
SECTION 7.	ELECTRICAL PARTS LIST	35

FEATURES

- The Dolby HX PRO* system which improves the linearity of a tape's high-range response during recording
- A relay function for long recording and playback.
- Automatic tape type detection during playback and recording.
- Auto-synchro dubbing at normal or high (double) speed.
- AMS and memory play functions which provide easy access to desired selections.
- An easy-to-read digital counter which shows the elapsed recording or playback time for decks A and B.

SAFETY-RELATED COMPONENT WARNING!!

COMPONENTS IDENTIFIED BY MARK  OR DOTTED LINE WITH MARK  ON THE SCHEMATIC DIAGRAMS AND IN THE PARTS LIST ARE CRITICAL TO SAFE OPERATION. REPLACE THESE COMPONENTS WITH SONY PARTS WHOSE PART NUMBERS APPEAR AS SHOWN IN THIS MANUAL OR IN SUPPLEMENTS PUBLISHED BY SONY.

ATTENTION AU COMPOSANT AYANT RAPPORT À LA SÉCURITÉ!

LES COMPOSANTS IDENTIFIÉS PAR UNE MARQUE  SUR LES DIAGRAMMES SCHÉMATIQUES ET LA LISTE DES PIÈCES SONT CRITIQUES POUR LA SÉCURITÉ DE FONCTIONNEMENT. NE REMPLACER CES COMPOSANTS QUE PAR DES PIÈCES SONY DONT LES NUMÉROS SONT DONNÉS DANS CE MANUEL OU DANS LES SUPPLÉMENTS PUBLIÉS PAR SONY.

SAFETY CHECK-OUT

After correcting the original service problem, perform the following safety check before releasing the set to the customer:

Check the antenna terminals, metal trim, "metallized" knobs, screws, and all other exposed metal parts for AC leakage. Check leakage as described below.

LEAKAGE TEST

The AC leakage from any exposed metal part to earth ground and from all exposed metal parts to any exposed metal part having a return to chassis, must not exceed 0.5 mA (500 microampers). Leakage current can be measured by any one of three methods.

1. A commercial leakage tester, such as the Simpson 229 or RCA WT-540A. Follow the manufacturers' instructions to use these instruments.
2. A battery-operated AC milliammeter. The Data Precision 245 digital multimeter is suitable for this job.
3. Measuring the voltage drop across a resistor by means of a VOM or battery-operated AC voltmeter. The "limit" indication is 0.75 V, so analog meters must have an accurate low-voltage scale. The Simpson 250 and Sanwa SH-63Trd are examples of a passive VOM that is suitable. Nearly all battery operated digital multimeters that have a 2V AC range are suitable. (See Fig. A)

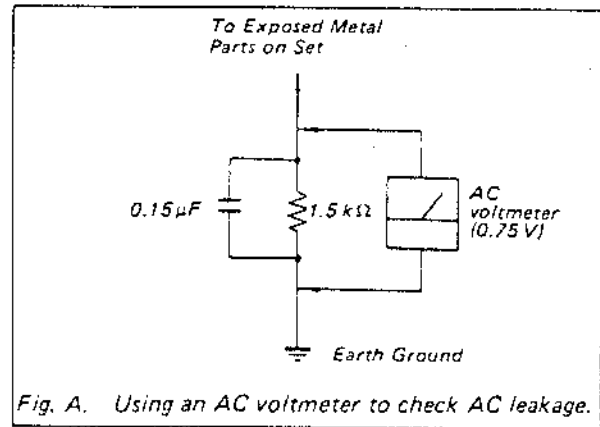

Fig. A. Using an AC voltmeter to check AC leakage.

SECTION 2 DISASSEMBLY

Note: Follow the disassembly procedure in the numerical order given.

2-1. FRONT PANEL (TC-WR775)

- 1 Remove the connector from audio system control board.

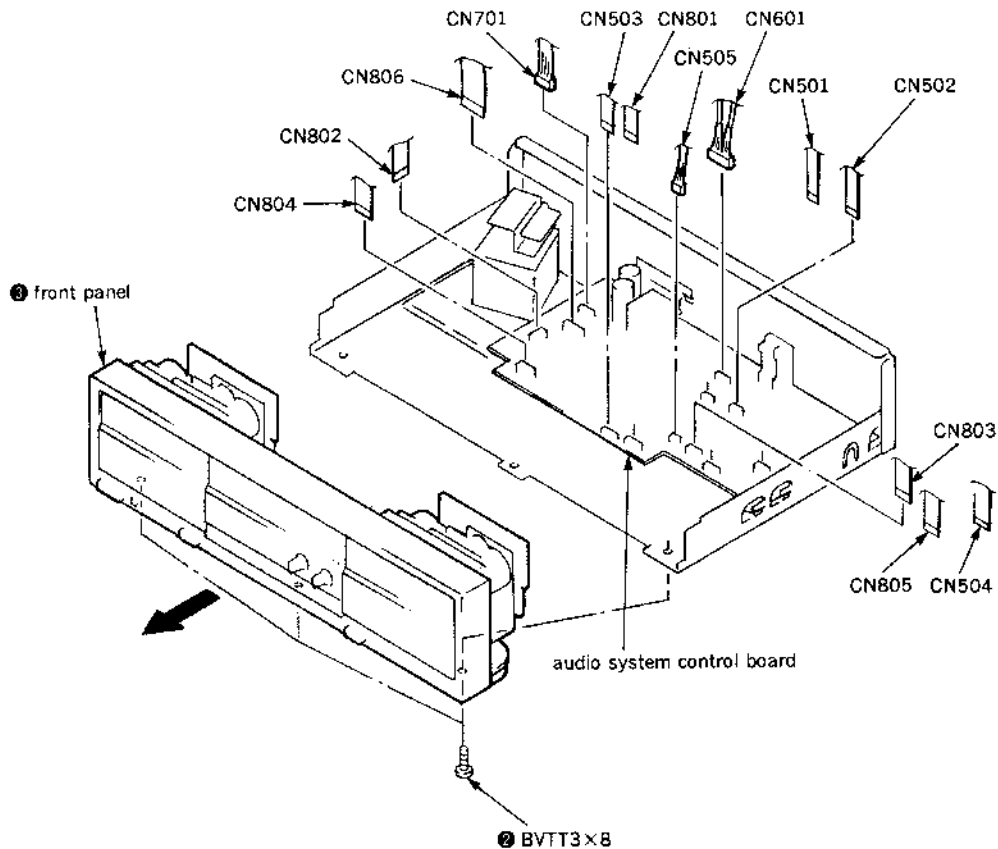

2-2. MECHANISM DECK (TC-WR775)

- 1 Push the EJECT button.

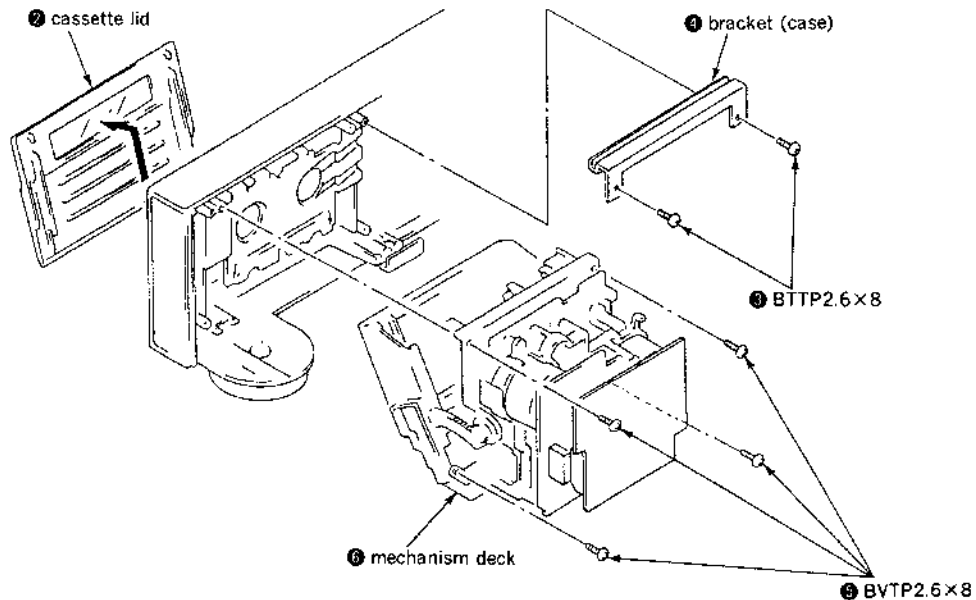

2-3. FRONT PANEL (TC-WR87ES)

- 1 Remove the connector from audio system control board.
- 2 Push the EJECT button.

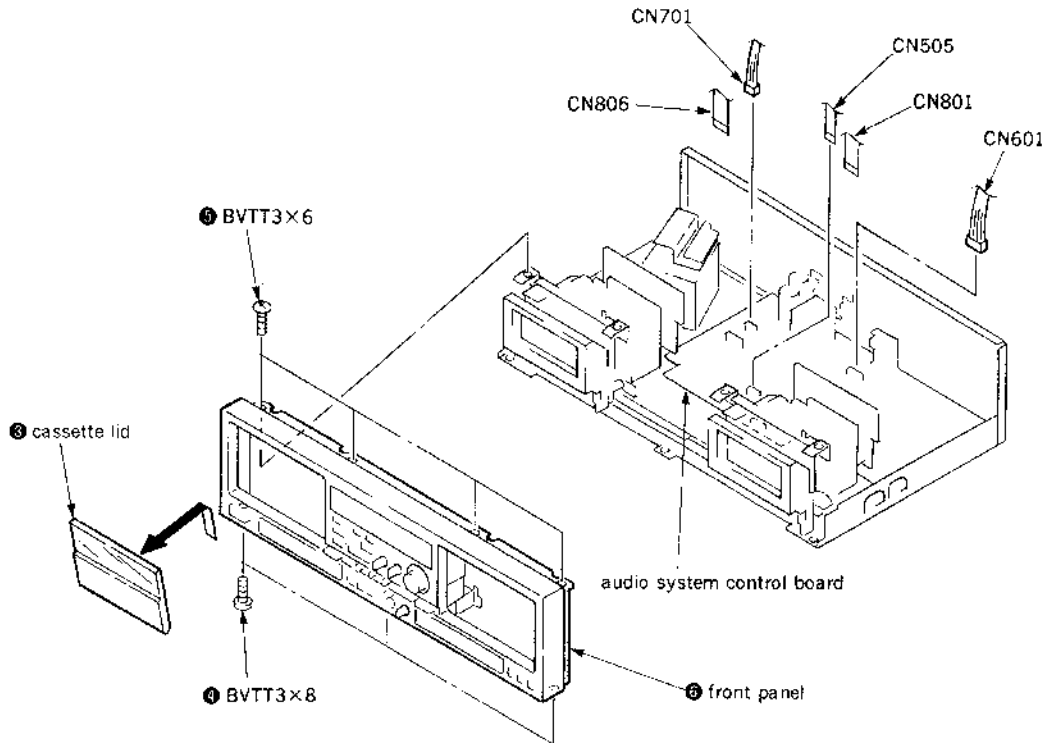

2-4. MECHANISM DECK (TC-WR87ES)

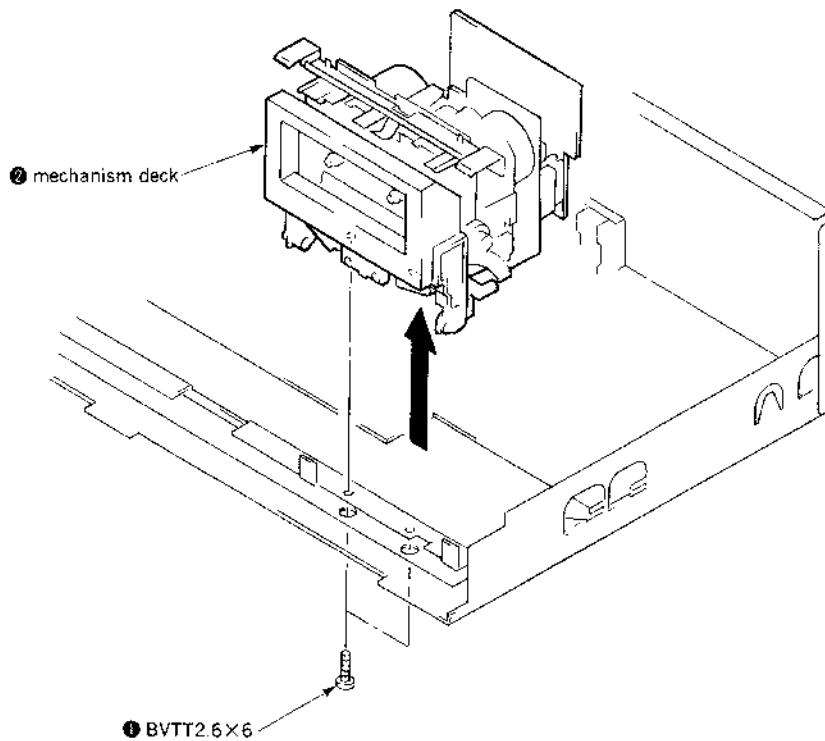

2-5. CAPSTAN MOTOR, REEL MOTOR (1)

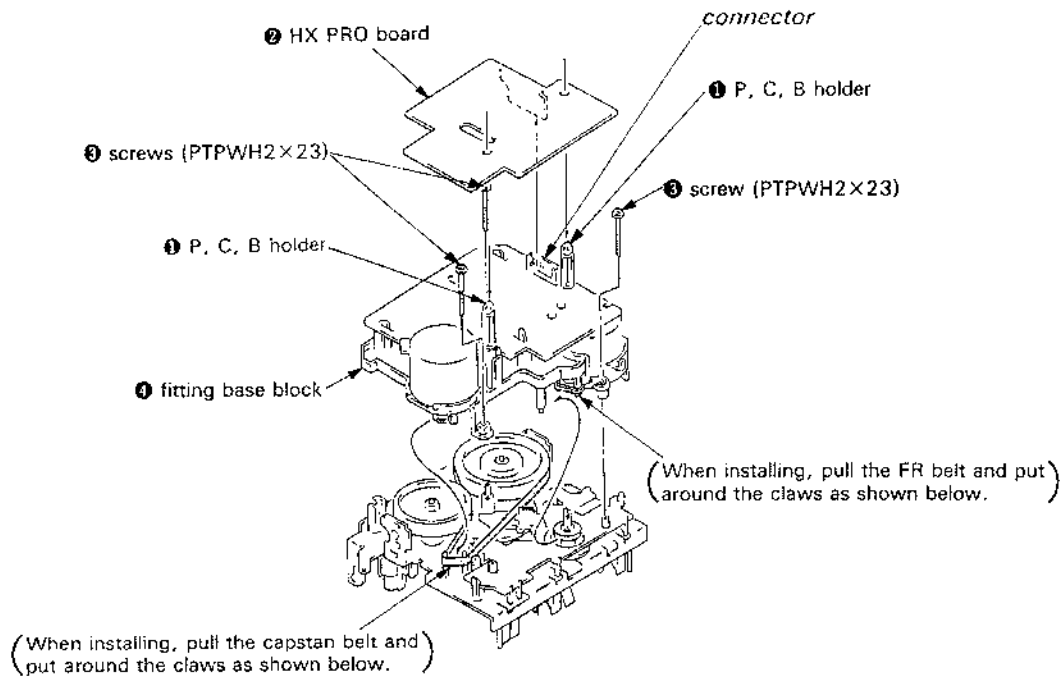

2-6. CAPSTAN MOTOR, REEL MOTOR (2)

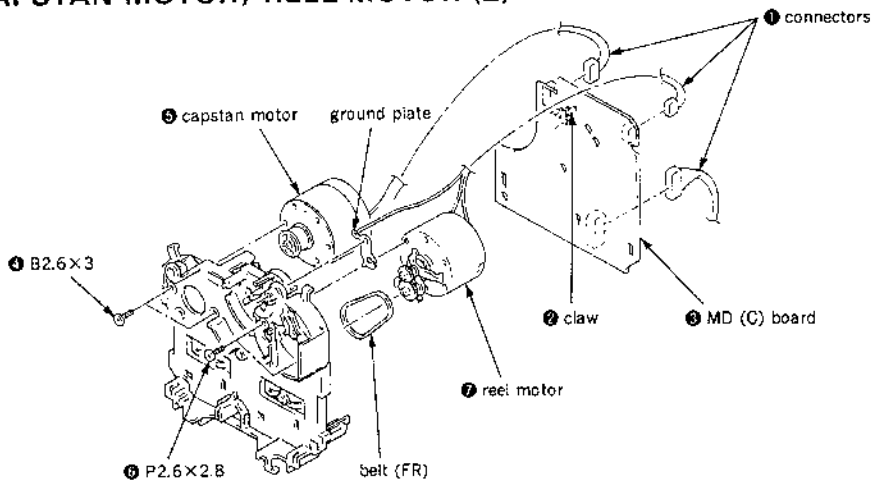

2-7. HEAD, PINCH ROLLER

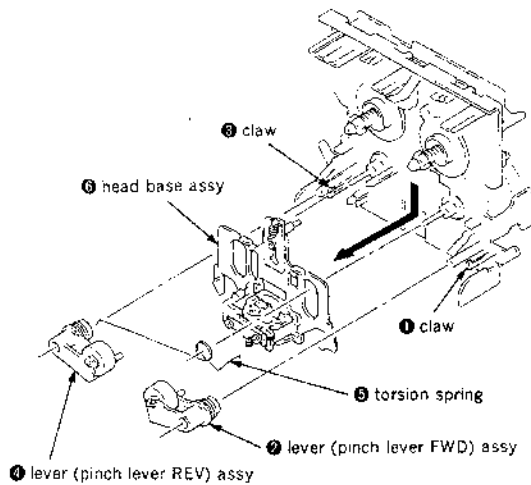

SECTION 3 MECHANICAL ADJUSTMENTS

PRECAUTION

1. Clean the following parts with a denatured alcohol-moistened swab:

record/playback/erase head	pinch roller
rubber belts	capstan
idlers	
2. Demagnetize the record/playback head with a head demagnetizer.
(Head demagnetizer do not approach for the erase head.)
3. Do not use a magnetized screwdriver for the adjustment.
4. After the adjustments, apply suitable locking compound to the parts adjusted.
5. The adjustments should be performed with the rated power supply voltage unless otherwise noted.

Torque Measurement

Torque	Torque meter	Meter reading
Forward	CQ-102C	30 to 65g·cm (0.42 to 0.90 oz·inch)
Forward back tension	CQ-102C	1 to 6g·cm (0.014 to 0.08 oz·inch)
Reverse	CQ-102RC	30 to 65g·cm (0.42 to 0.90 oz·inch)
Reverse back tension	CQ-102RC	1 to 6g·cm (0.014 to 0.08 oz·inch)
Forward, Reverse	CQ-201B	70 to 120g·cm (0.98 to 1.67 oz·inch)

SECTION 4 ELECTRICAL ADJUSTMENTS

PRECAUTION

1. The adjustment should be performed in the publication.
(Be sure to make playback adjustment at first.)
2. The adjustment and measurement should be performed for both L-CH and R-CH.
 - Switch position
 - DOLBY NR switch : OFF
 - DIR MODE switch : ⇄
 - Standard record position
 - Deliver the standard input signal level to input jack and set the REC LEVEL control to obtain the standard output signal level as follows.

—Record Mode—

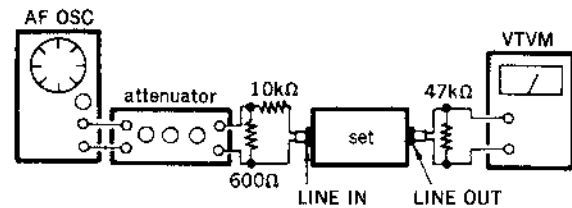

Standard Input Level

Input terminal	LINE IN
source impedance	10kΩ
input signal level	0.25V (-10dB)

Standard Output Level

Output terminal	LINE OUT
load impedance	47kΩ
output signal level	0.44V (-5dB)

Test Tape

Tape	Contents	Use
P-4-A100	10kHz, -10dB	Azimuth Adjustment
P-4-L300	315Hz, 0dB	Level Adjustment
WS-48B	3kHz, 0dB	Tape Speed Adjustment

3. When to electrical adjustments, short the connector TP1 (test mode).

audio system control board —component side

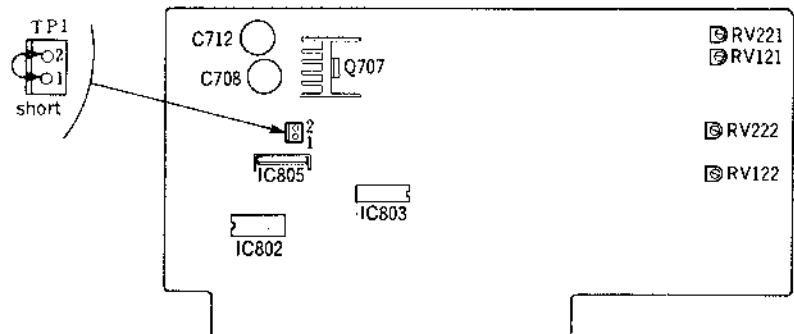

Record/Playback/Erase Head Azimuth Adjustment

DECK A **DECK B**

Procedure :

1. Reverse Playback Mode

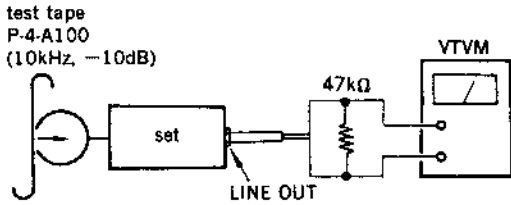

2. Turn the adjustment screw for the maximum output levels. If these levels do not match, turn the adjustment screw until both of output levels match together within 1dB.

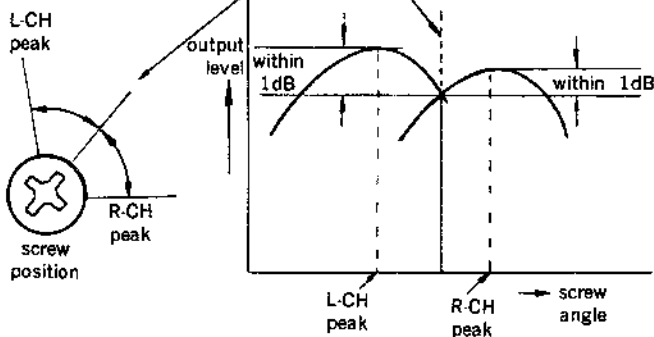

3. Playback Mode

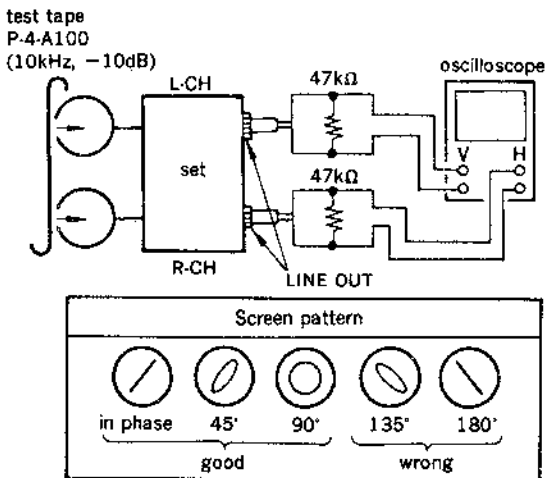

4. Change the forward playback mode and repeat the steps 1 to 3.
5. After the adjustment, lock the adjustment screws with suitable locking compound.

Adjustment Location : — record/playback/erase head —

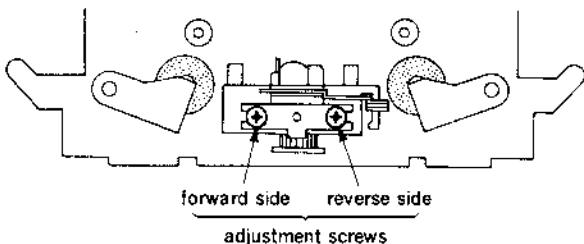

Tape Speed Adjustment **DECK A** **DECK B**

Perform high speed adjustment before normal speed adjustment.

Procedure :

— Forward Playback Mode —

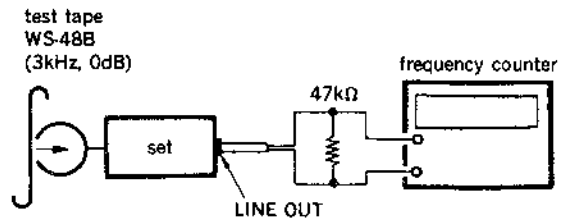

(high speed adjustment)

1. Keep on pressing the SYNCHRO DUBBING HIGH SPEED switch.
2. Confirm that the frequency counter reading becomes within adjustment limits of $6,000 \pm 60\text{Hz}$ on both of deck A and deck B.
3. If the adjustment limits are not satisfied, adjust each RV72 so that the frequency counter reading becomes within adjustment limits of $6,000 \pm 30\text{Hz}$ on both of deck A and deck B.
4. Change the reverse playback mode and repeat the steps 1 to 3.

(normal speed adjustment)

5. Keep on pressing the SYNCHRO DUBBING NORM SPEED switch.
6. Confirm that the frequency counter reading becomes within adjustment limits of $3,000 \pm 30\text{Hz}$ on both of deck A and deck B.
7. If the adjustment limits are not satisfied, adjust each RV71 so that the frequency counter reading becomes within adjustment limits of $3,000 \pm 15\text{Hz}$ on both of deck A and deck B.
8. Change the reverse playback mode and repeat the steps 5 to 7.

Frequency difference between the beginning and the end of the tape should be within 3%.

Frequency difference between deck A and deck B the beginning of the tape should be within 1.5%.

Adjustment Location : MD (C) board (deck A, deck B)

(See page 10)

Playback Level Adjustment DECK A DECK B

Procedure :

—Forward Playback Mode—

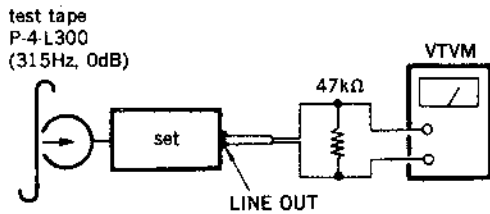

Adjust each RV11 (L-CH) and RV21 (R-CH) so that the VTVM reading becomes within adjustment limits below on both of deck A and deck B.

Adjustment Limits :

LINE OUT level: $-15 \pm 0.5\text{dB}$ (0.130 to 0.146V)

Level difference between channels: within 0.5dB

Confirm the LINE OUT level does not change in playback mode while changing the mode from playback to stop several times.

Adjustment Location : MD(C) board (deck A, deck B)
(See page 10)

Bias Consumption Current Adjustment

DECK A DECK B

This adjustment should be performed when replacing the head assy or step-up transformer (T0391, 0491 (deck A) and T391, 491 (deck B)), or DOLBY HX-PRO IC (IC0691 (deck A) and IC691 (deck B)).

Procedure :

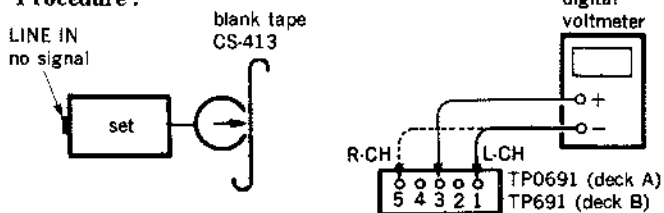

(deck A)

1. Connect the digital voltmeter to test point TP0691.
2. Set RV0391 (L-CH) and RV0491 (R-CH) to mechanical center.
3. Set to forward record mode.
4. Adjust T0391 (L-CH) and T0491 (R-CH) so that the digital voltmeter reading becomes minimum.

(deck B)

5. Similarly, connect the digital voltmeter to test point TP691.
6. Set RV391 (L-CH) and RV491 (R-CH) to mechanical center.
7. Set to forward record mode.
8. Adjust T391 (L-CH) and T491 (R-CH) so that the digital voltmeter reading becomes minimum.

Adjustment Location : HX-PRO board (A) (deck A),
HX-PRO board (B) (deck B)
(See page 10)

Record Bias Adjustment DECK A DECK B

Setting :

REC LEVEL control: standard record position (Refer to page 7.)

Procedure :

1. Record Mode

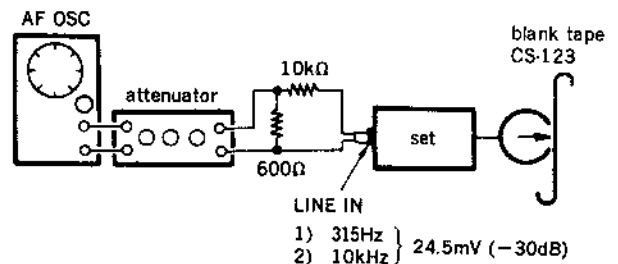

2. Playback Mode

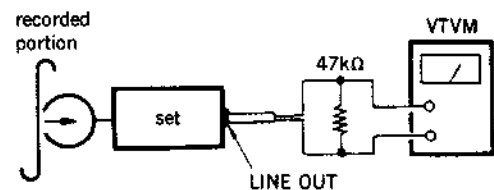

(deck A)

3. Playback the signal recorded in step 1, and confirm that the 10kHz playback output level is VTVM reading becomes within adjustment limits below relative to the 315Hz output.
4. If the adjustment limits are not satisfied, adjust each RV0391 (L-CH) and RV0491 (R-CH) so that the VTVM reading becomes within adjustment limits on next page.

(deck B)

5. Similarly, playback the signal recorded in step 1, and confirm that the 10kHz playback output level is VTVM reading becomes within adjustment limits below relative to the 315Hz output.
6. If the adjustment limits are not satisfied, adjust each RV391 (L-CH) and RV491 (R-CH) so that the VTVM reading becomes within adjustment limits on next page.

Adjustment Limits :

10kHz playback output
relative to the 315Hz output : $0 \pm 0.5\text{dB}$

Adjustment Location : HX-PRO board(A)(deck A)
HX-PRO board(B)(deck B)

Record Level Adjustment DECK A DECK B

Setting :

REC LEVEL control : standard record position (Refer to page 7.)

Procedure :

1. Record Mode

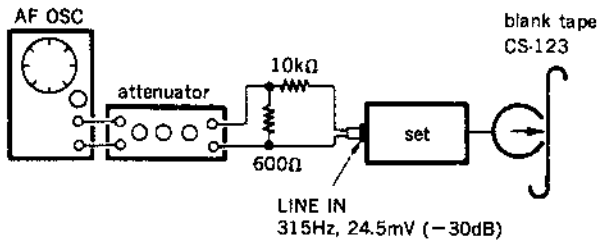

2. Playback Mode

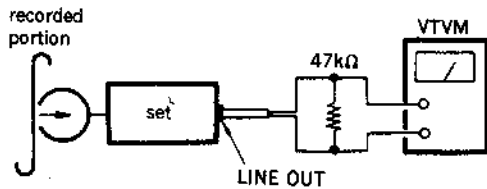

(deck A)

3. Playback the signal recorded in step 1, and confirm that the 10kHz playback output level is VTVM reading becomes within adjustment limits below relative to the 315Hz output.
4. If the adjustment limits are not satisfied, adjust each RV121 (L-CH) and RV221 (R-CH) so that the VTVM reading becomes within adjustment limits below.

(deck B)

5. Similarly, playback the signal recorded in step 1, and confirm that the 10kHz playback output level is VTVM reading becomes within adjustment limits below relative to the 315Hz output.
6. If the adjustment limits are not satisfied, adjust each RV122 (L-CH) and RV222 (R-CH) so that the VTVM reading becomes within adjustment limits below.

Adjustment Limits :

315Hz playback output level : $-25 \pm 0.5\text{dB}$ (42 to 46mV)

Adjustment Location : audio system control board

Note : After adjustment, open the connector TP1.

—Adjustment Parts Location Diagrams—

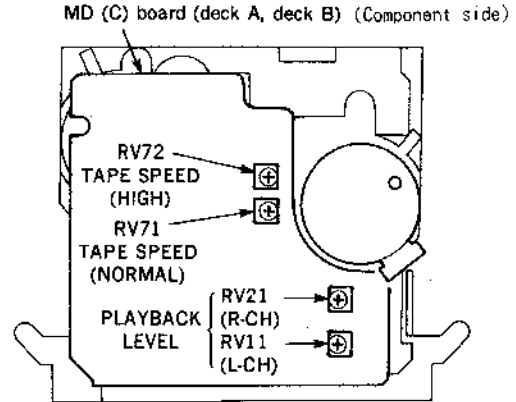

HX-PRO board (A) (deck A),
HX-PRO board (B) (deck B) (Component side)

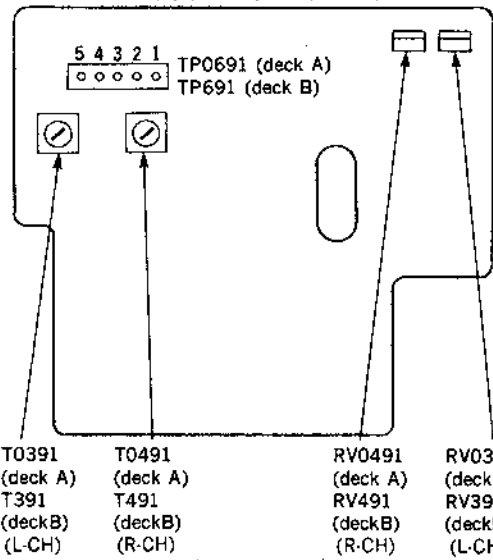

BIAS CONSUMPTION CURRENT

RECORD BIAS and BIAS CONSUMPTION CURRENT

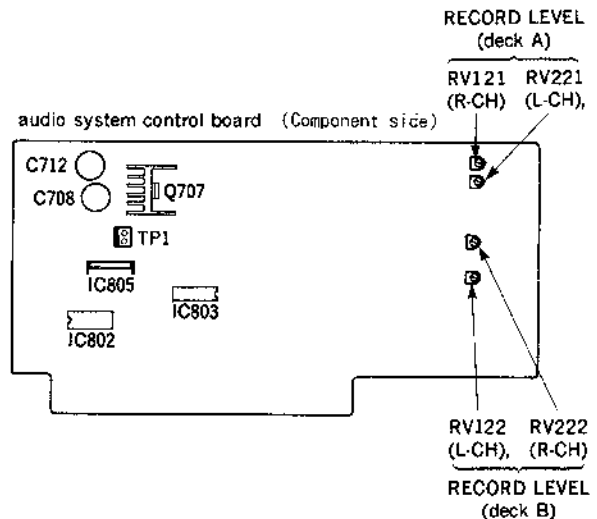

SECTION 5 DIAGRAMS

5-1. CIRCUIT BOARDS LOCATION

(TC-WR775)

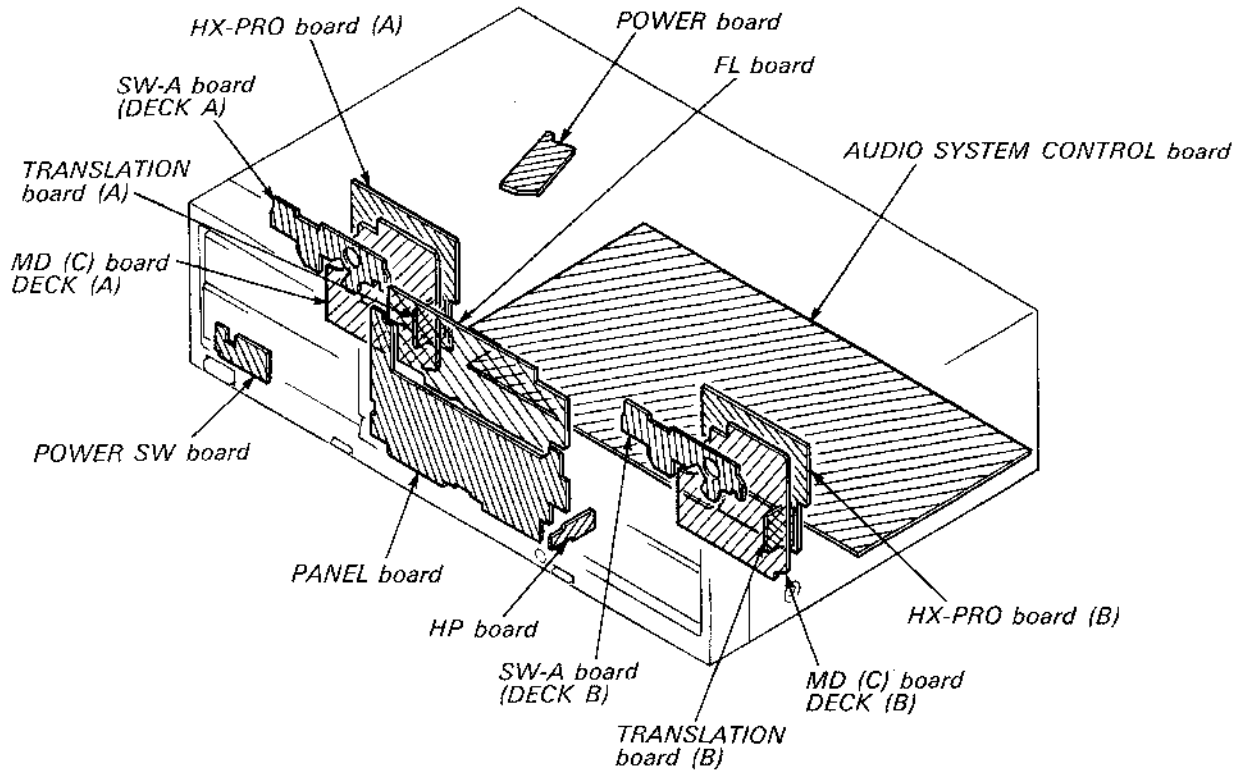

(TC-WR87ES)

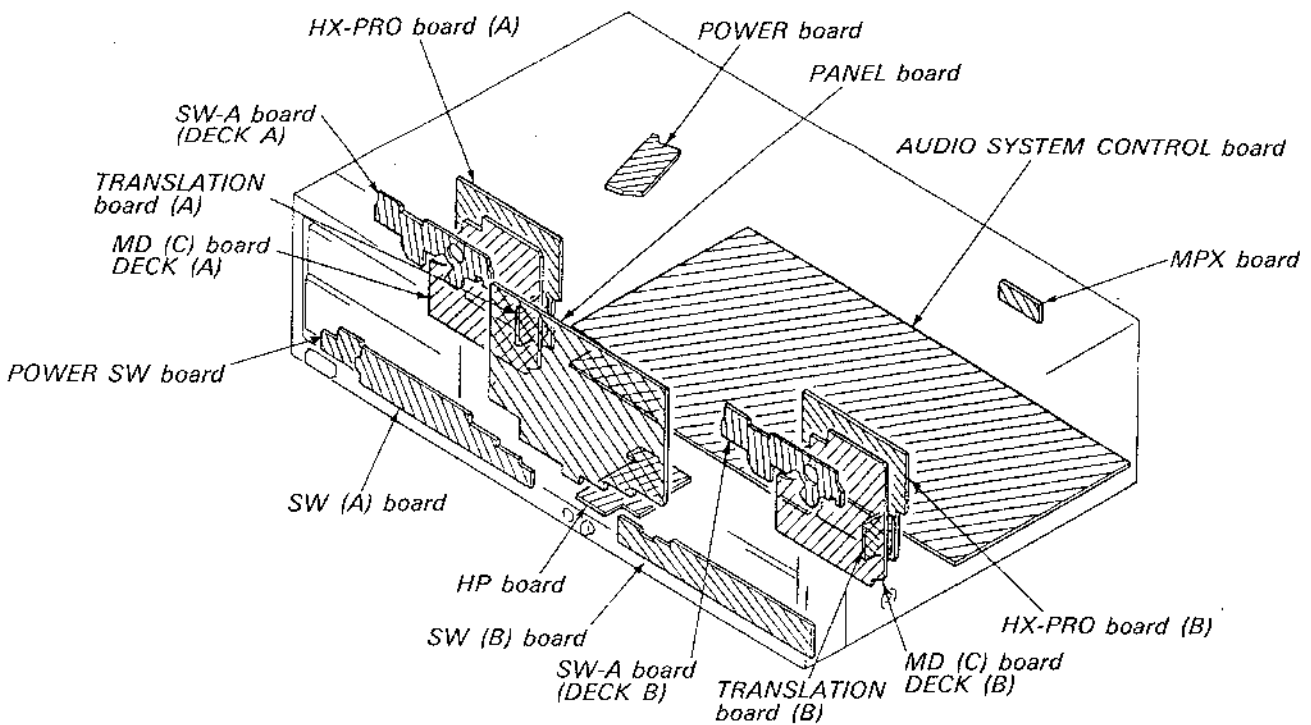

5-2. SEMICONDUCTOR LEAD LAYOUTS

DTA114ES
DTA144ES
DTC114ES
DTC143TS
DTC144ES
DTC144WS
2SC2603-EF
2SD1012-FG



HZS6A1L
HZS7A1L
HZS9A2L
UZL-11L2
UZL-7H1
1SS120

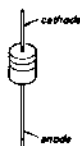

2SA1317-S
2SA1317-STU
2SB1013-3



10E2N

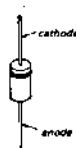

2SB1370-EF

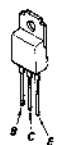

2SD1312-K

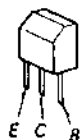

NJL5165K-B

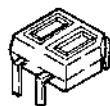

• Semiconductor Location

Ref. No.	Location	Ref. No.	Location
D31	K-14	Q121	B-2
D131	D-5	Q171	D-4
D231	E-5	Q201	B-6
D501(*1)	D-4	Q202	B-6
D502	D-5	Q221	B-2
D503	C-4	Q271	E-4
D571	E-5	Q501	D-5
D572	E-5	Q502	D-5
D601	D-11	Q503	D-5
D602	D-10	Q504	C-4
D701	C-11	Q505	C-4
D702	C-12	Q521	F-5
D703	C-13	Q551	F-4
D704	B-13	Q552	E-2
D705	B-13	Q553	D-2
D706	C-14	Q571	E-5
D707	B-13	Q572	E-5
D708	B-13	Q601	F-6
D709	C-10	Q701	A-11
D710	B-13	Q702	B-11
D711	B-13	Q703	C-12
D712	B-10	Q704	C-12
D713	C-13	Q705	A-10
D801	F-7	Q706	B-9
D811	G-12	Q707	B-11
D812	H-11	Q708	B-9
IC31	K-12	Q801	F-3
IC81	L-21	Q802	G-13
IC82(*2)	L-19	Q803	G-12
IC501	B-5	Q804	G-12
IC503	F-7	Q805	E-10
IC504	E-5	Q806	F-10
IC506	D-6	Q807	F-7
IC509	D-2	Q851	G-10
IC510	F-4	Q852	G-10
IC511	B-1	Q853	F-9
IC511	B-1	Q854	G-10
IC601(*1)	E-4	Q854	G-10
IC601(*2)	F-32	Q891	F-8
IC691	J-8	Q901(*1)	H-21
IC701	B-10	Q901(*2)	F-25
IC802	F-12	Q902(*1)	H-22
IC803	E-9	Q902(*2)	F-26
IC804	F-11	Q903(*1)	H-22
IC805	F-11	Q903(*2)	F-26
IC805	D-12	Q904(*1)	H-18
IC806	F-10	Q904(*2)	F-30
IC807	G-11	Q905(*1)	I-21
IC901(*1)	H-19	Q905(*2)	E-26
IC901(*2)	F-28	Q906(*1)	I-22
IC902(*1)	H-23	Q906(*2)	E-25
IC902(*2)	F-24	Q907(*1)	I-21
IC0691	J-3	Q907(*2)	E-26
Q51	J-14	Q908(*1)	H-21
Q52	J-13	Q908(*2)	E-26
Q53	K-14	Q909(*1)	I-21
Q71	J-13	Q909(*2)	E-26
Q101	C-6		
Q102	C-6		

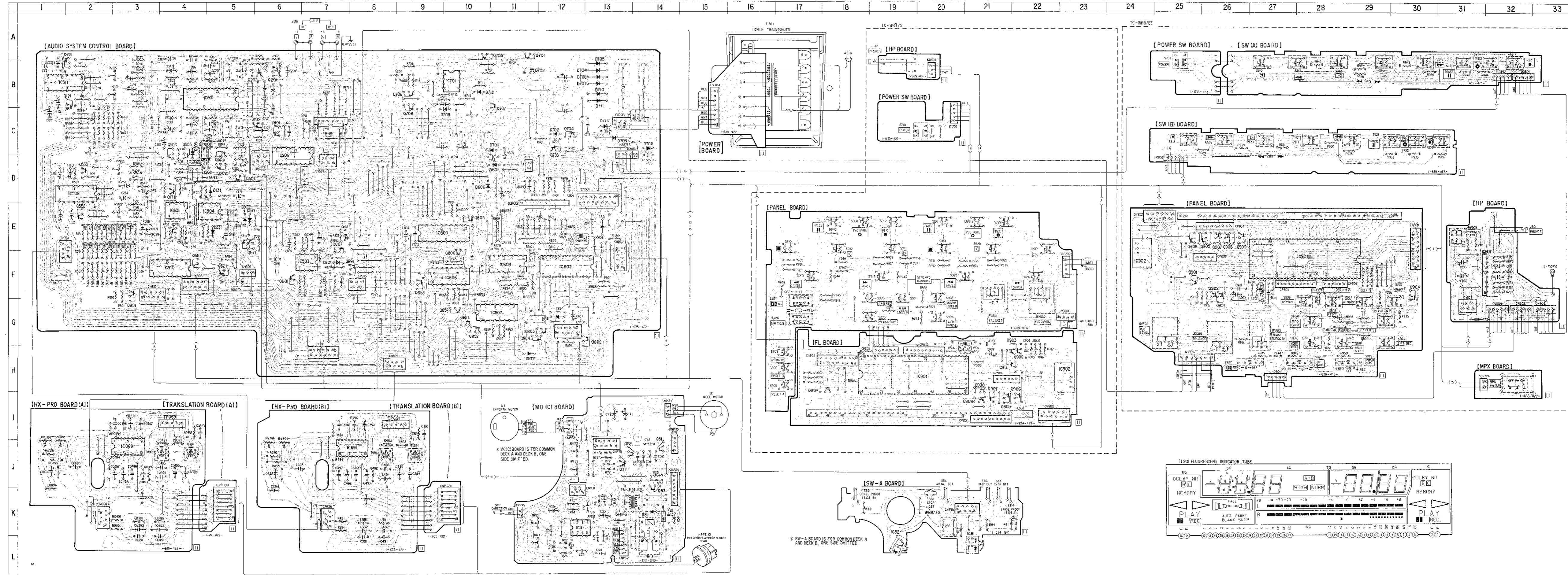

*1 : Used on TC-WR775 only.
*2 : Used on TC-WR87ES only.

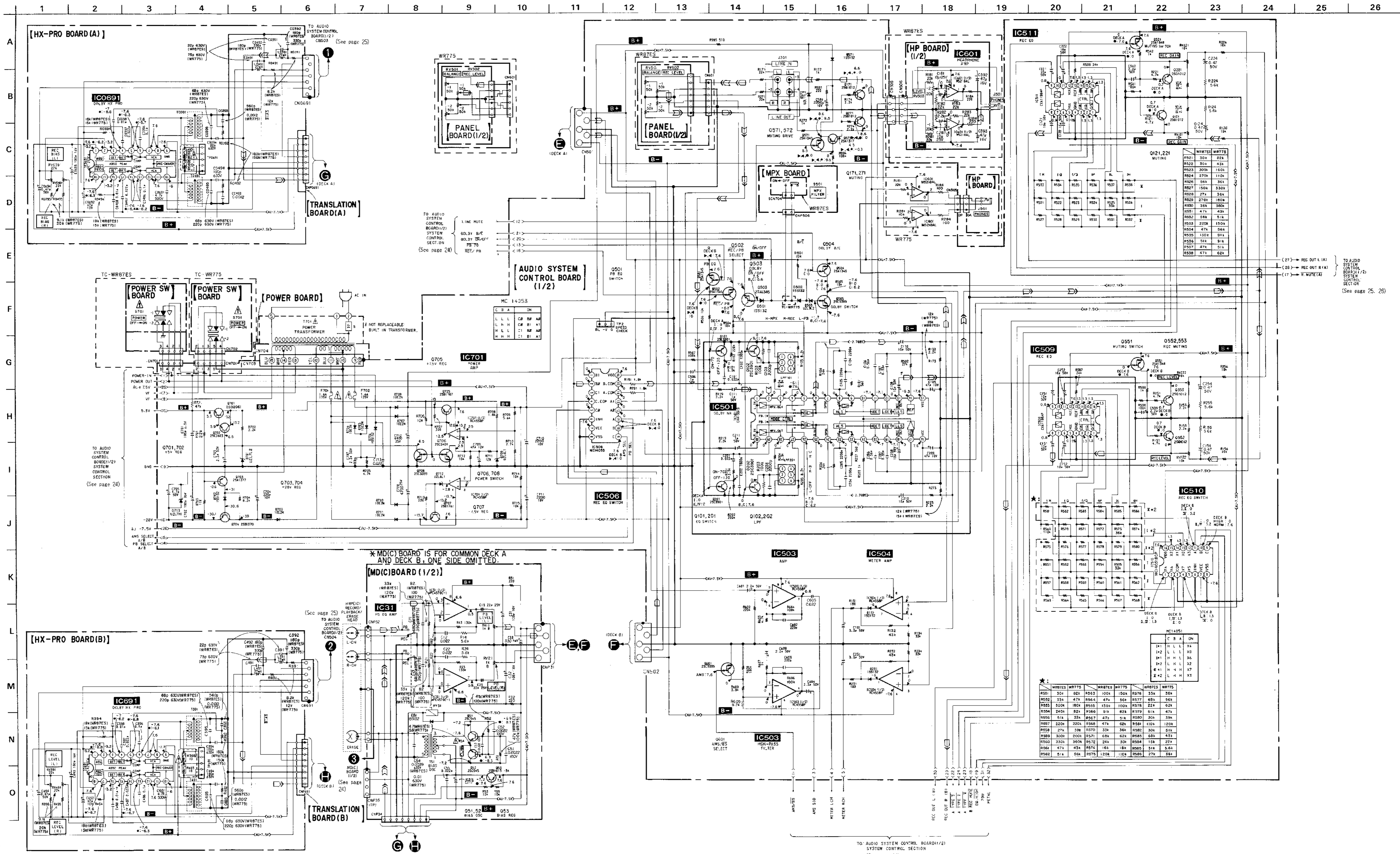

• IC Block Diagrams

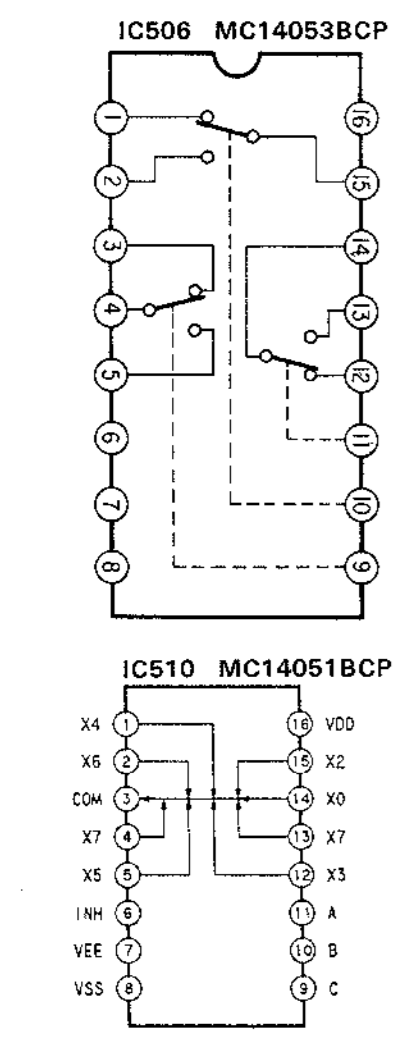

- Note:
- All capacitors are in μF unless otherwise noted. pF: μF 50WV or less are not indicated except for electrolytics and tantalums.
 - All resistors are in Ω and $\frac{1}{2}$ W or less unless otherwise specified.
 - Δ : internal component.
 - \square : fusible resistor.
- Note:
- The components identified by mark Δ or \square are critical for safety. Replace only with part number specified.
 - Les composants identifiés par une marque Δ ou \square sont critiques pour la sécurité. Ne les remplacer que par une pièce portant le numéro spécifié.
- B+ : B+ Line
 - B- : B- Line
 - REV : adjustment for repair.
 - Voltage is dc with respect to ground under no-signal (detuned) conditions.
 - no mark: POWER ON
 - FF : FF
 - REV : REV
 - REC : REC
 - Voltagés are taken with a VOM (input impedance 10M Ω). Voltage variations may be noted due to normal production tolerances.
 - Signal path.
 - PB (DECK A)
 - REC (DECK A)
 - PB (DECK B)
 - REC (DECK B)
 - WR75: TC-WR75
 - WR7ES: TC-WR7ES

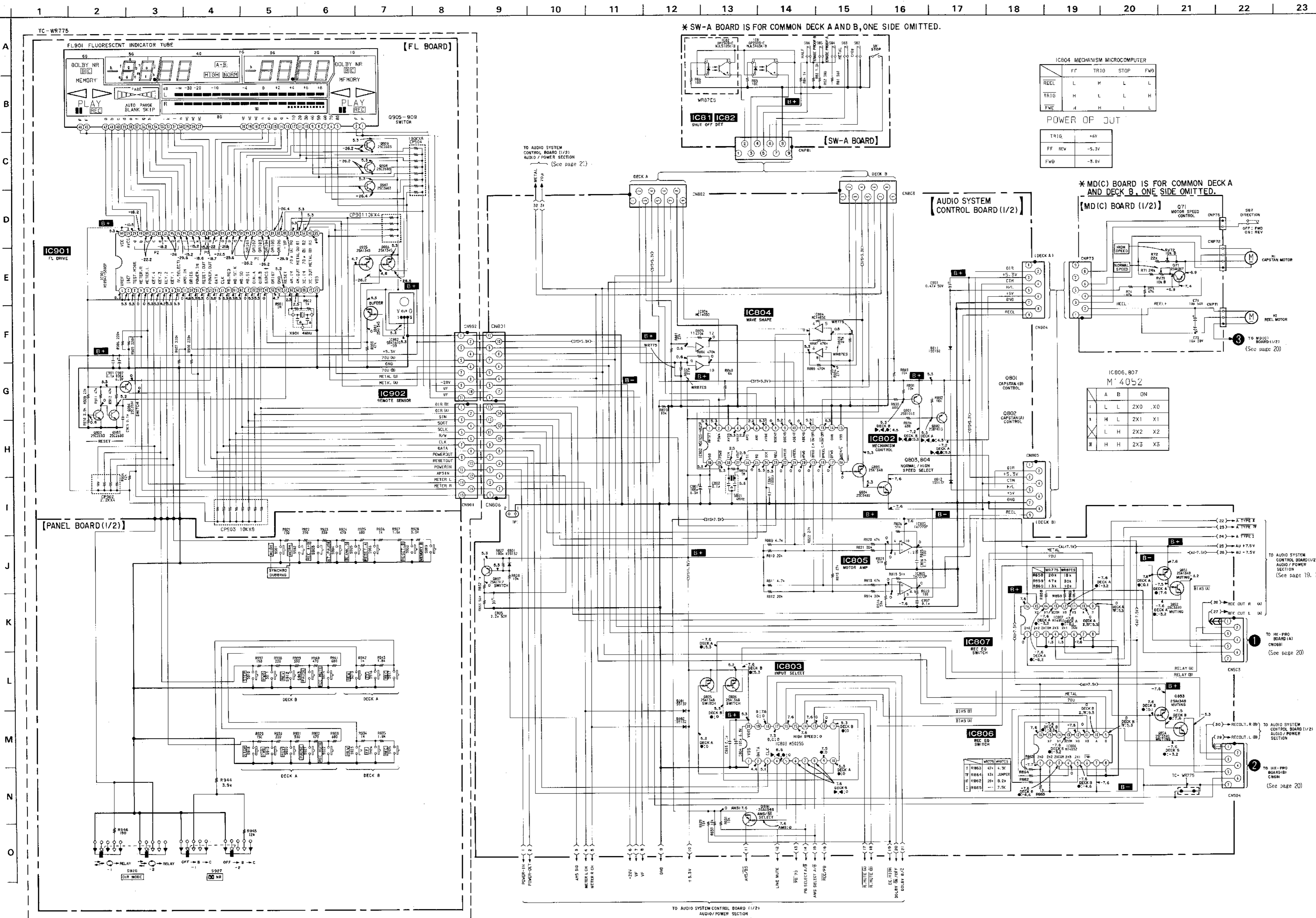

Note:

- All capacitors are in μF unless otherwise noted. pF : μF 50WV or less are not indicated except for electrolytics and tantalums.
- All resistors are in Ω and $\frac{1}{4}\text{W}$ or less unless otherwise specified.
- Δ : Internal component.
- $\text{B}+$: B+ Line
- $\text{B}-$: B- Line
- B : adjustment for repair.
- Volts are dc with respect to ground under no-signal (detuned) conditions.
- no mark: POWER ON
- \blacktriangle : FWD \blacktriangleleft : REV \bullet : REC
- Volts are taken with a VOM (Input Impedance 10M Ω). Voltage variations may be noted due to normal production tolerances.
- Signal path.
- REC DECK A
- REC DECK B
- WR775: TC-WR775
- WR875: TC-WR875

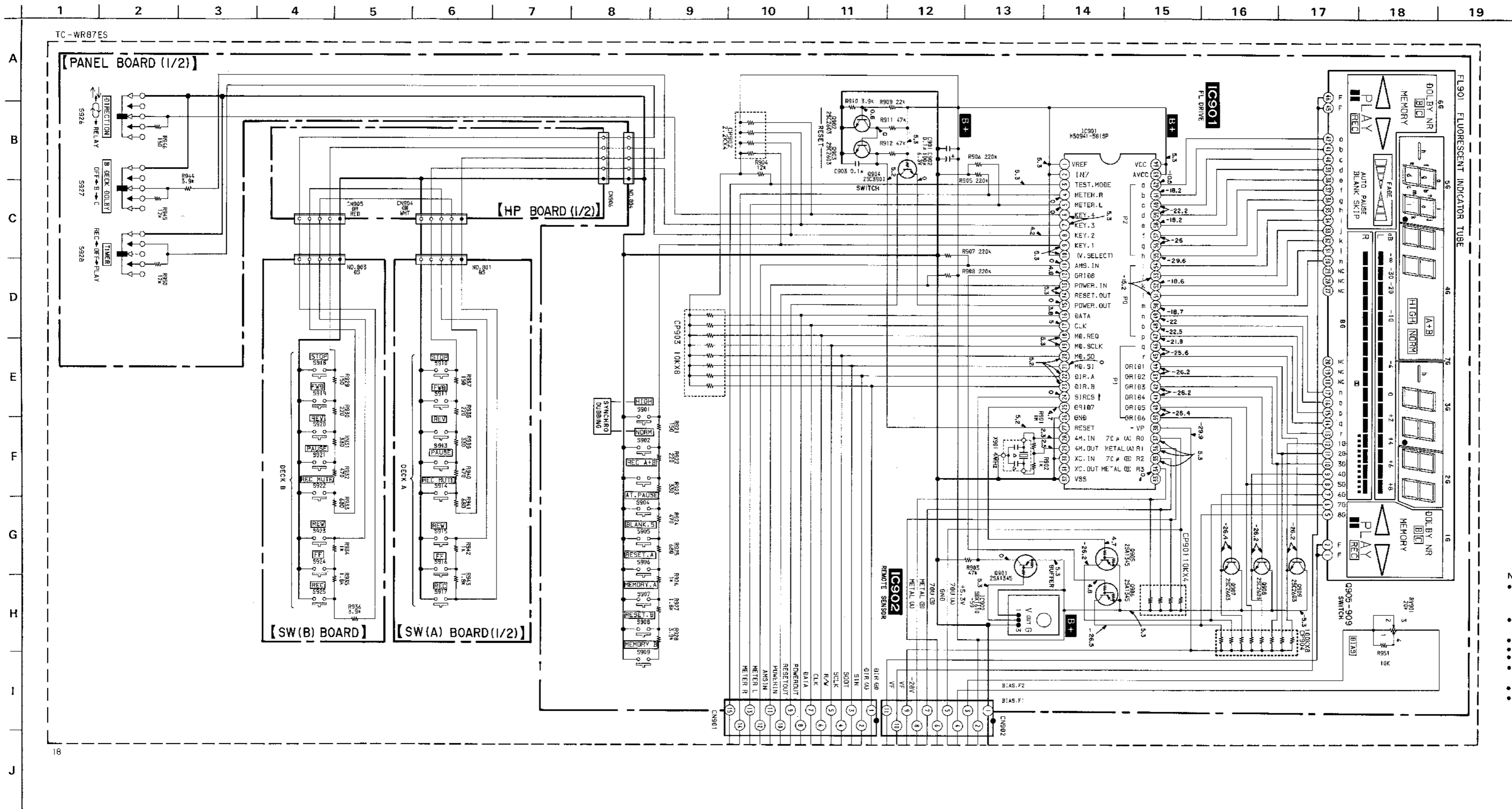

Note:



- All capacitors are in μF unless otherwise noted. pF: μF 50WV or less are not indicated except for electrolytics and tantalums.
- All resistors are in Ω and $\frac{1}{2}W$ or less unless otherwise specified.
- Δ : internal component.
- **B+** : B+ Line
- **B-** : B- Line
- Voltage is dc with respect to ground under no-signal (detuned) conditions.
- no mark: POWER ON
- Voltages are taken with a VOM (input Impedance $10M\Omega$). Voltage variations may be noted due to normal production tolerances.

SECTION 6 EXPLODED VIEWS

NOTE:

- -XX, -X mean standardized parts, so they may have some differences from the original one.
- The mechanical parts with no reference number in the exploded views are not supplied.
- Items marked "*" are not stocked since they are seldom required for routine service. Some delay should be anticipated when ordering these items.

- Color Indication of Appearance Parts
Example:
KNOB, BALANCE(WHITE)...(RED)
 ↑ ↑
Part's Color Cabinet's Color
- Hardware (#mark) list is given in the last of this parts list.
- WR775 : TC-WR775
WR87ES : TC-WR87ES

The components identified by mark  or dotted line with mark  are critical for safety. Replace only with part number specified.

Les composants identifiés par une marque  sont critiques pour la sécurité. Ne les remplacer que par une pièce portant le numéro spécifié.

6-1. CHASSIS SECTION

- A : power board
- F : MPX board
- B-F : see page 31,32

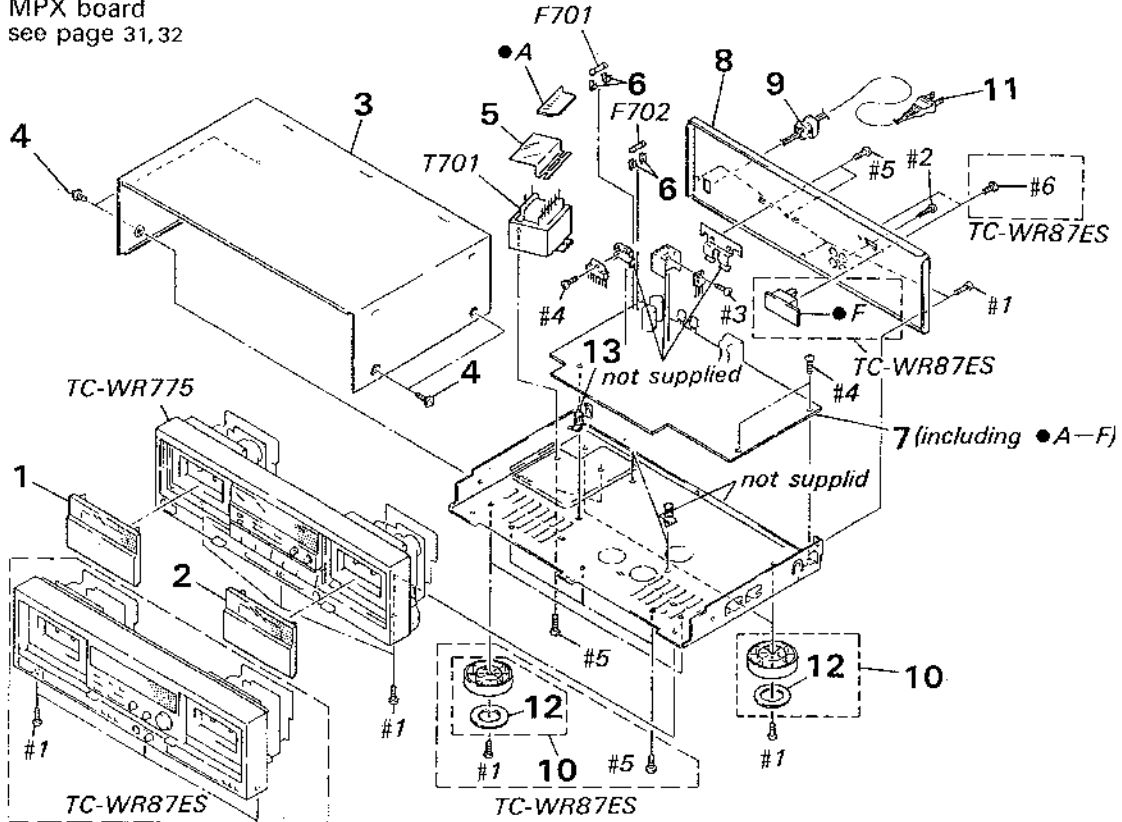

Ref. No.	Part No.	Description	Remark	Ref. No.	Part No.	Description	Remark
1	X-3363-194-1	LID (A) ASSY, CASSETTE (WR87ES)		8	* 3-365-370-01	PANEL, BACK (WR87ES)	
1	X-3362-988-1	LID (A) ASSY, CASSETTE (WR775)		8	* 3-365-371-11	PANEL, BACK (WR775)	
2	X-3363-193-1	LID (B) ASSY, CASSETTE (WR87ES)		9	* 3-703-244-00	BUSHING (2104), CORD (WR87ES)	
2	X-3362-989-1	LID (B) ASSY, CASSETTE (WR775)		9	* 3-703-571-11	BUSHING (S) (4516), CORD (WR775)	
3	* 4-929-294-52	CASE (WR87ES)		10	X-3304-933-2	FOOT ASSY (WR87ES)	
3	* 4-929-294-42	CASE (WR775)		10	X-4885-950-1	FOOT ASSY (WR775)	
4	3-704-366-01	SCREW (CASE) (M3X8)		11	△ 1-555-465-00	CORD, POWER (WR87ES)	
5	* 3-337-136-11	COVER, TRANSFORMER SAFETY		11	△ 1-551-506-XX	CORD, POWER (WR775)	
6	* 1-533-213-31	HOLDER, FUSE		12	4-923-836-11	CUSHION	
7	* A-2006-511-A	SYSTEM CONTROL BOARD, COMPLETE (WR87ES)		13	* 3-346-265-11	HOLDER, PC BOARD	
7	* A-2006-517-A	SYSTEM CONTROL BOARD, COMPLETE (WR775)		F701	△ 1-532-742-11	FUSE, GLASS TUBE (1.5A/125V)	
				F702	△ 1-532-742-11	FUSE, GLASS TUBE (1.5A/125V)	
				T701	△ 1-450-431-11	TRANSFORMER, POWER	

6-2. FRONT PANEL SECTION (TC-WR775)

- B : HX-PRO board (A)
- C : HX-PRO board (B)
- D : translation board (A)
- E : translation board (B)
- F : power SW board
- ▲A : FL board
- ▲B : HP board

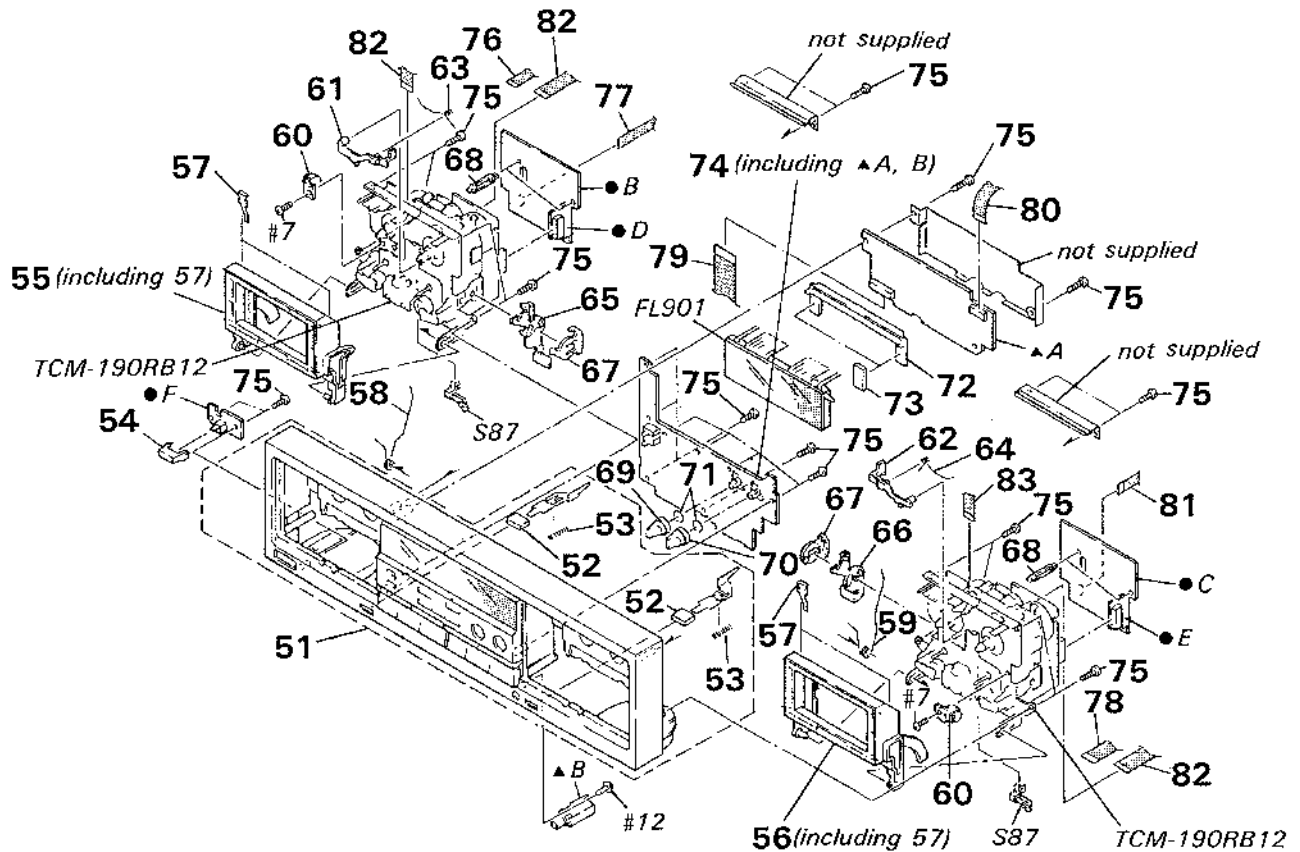

Ref. No.	Part No.	Description	Remark	Ref. No.	Part No.	Description	Remark
51	X-3363-192-1	PANEL ASSY. FRONT (WR775)		68	* 3-682-419-21	HOLDER, P. C. B	
52	3-340-188-11	BUTTON (EJECT) (WR775)		69	3-367-431-01	KNOB (BAL) (WR775)	
53	3-363-762-01	SPRING, COMPRESSION (WR775)		70	3-367-431-11	KNOB (REC) (WR775)	
54	3-354-932-01	BUTTON (POWER)		71	3-356-957-01	SPRING (WR775)	
55	X-3340-195-1	HOLDER (R) ASSY, CASSETTE		72	3-365-420-01	HOLDER, FL TUBE	
56	X-3340-194-1	HOLDER (L) ASSY, CASSETTE		73	* 9-911-844-XX	CUSHION (WR775)	
57	3-308-823-11	SPRING		74	* A-2006-518-A	PANEL BOARD, COMPLETE (WR775)	
58	3-354-960-01	SPRING (LOADING R), TORSION		75	4-928-635-01	SCREW, +BV (2.6X8) TAPPING	
59	3-354-959-01	SPRING (LOADING L), TORSION		76	* 1-575-847-11	WIRE, FLAT TYPE (5 CORE)	
60	3-354-963-01	DAMPER		77	* 1-575-851-11	WIRE, FLAT TYPE (7 CORE)	
61	3-354-956-01	LEVER (EJ SAFTY LEVER R)		78	* 1-575-848-11	WIRE, FLAT TYPE (5 CORE)	
62	3-354-955-01	LEVER (EJ SAFTY LEVER L)		79	* 1-575-853-11	WIRE, FLAT TYPE (15 CORE)	
63	3-354-962-01	SPRING (EJ SAFTY SPRING R)		80	1-534-517-00	WIRE, FLAT TYPE (11 CORE)	
64	3-354-961-01	SPRING (EJ SAFTY SPRING L)		81	* 1-575-780-11	WIRE, FLAT TYPE (7 CORE)	
65	* 3-354-954-01	LEVER (LOCK LEVER R)		82	* 1-575-850-11	WIRE, FLAT TYPE (9 CORE)	
66	* 3-354-953-01	LEVER (LOCK LEVER L)		83	* 1-575-781-11	WIRE, FLAT TYPE (9 CORE)	
67	3-354-957-01	JOINT (LOCK LEVER)		FL901	1-519-594-11	INDICATOR TUBE, FLUORESCENT	
				S87	1-572-393-11	SWITCH, LEAF (DIRECTION)	

6-3. FRONT PANEL SECTION (TC-WR87ES)

- B : HX-PRO board (A)
- C : HX-PRO board (B)
- D : translation board (A)
- E : translation board (B)
- F : power SW board
- ▲ A : SW (A) board
- ▲ B : SW (B) board
- ▲ C : HP board
- ▲ D : power SW board

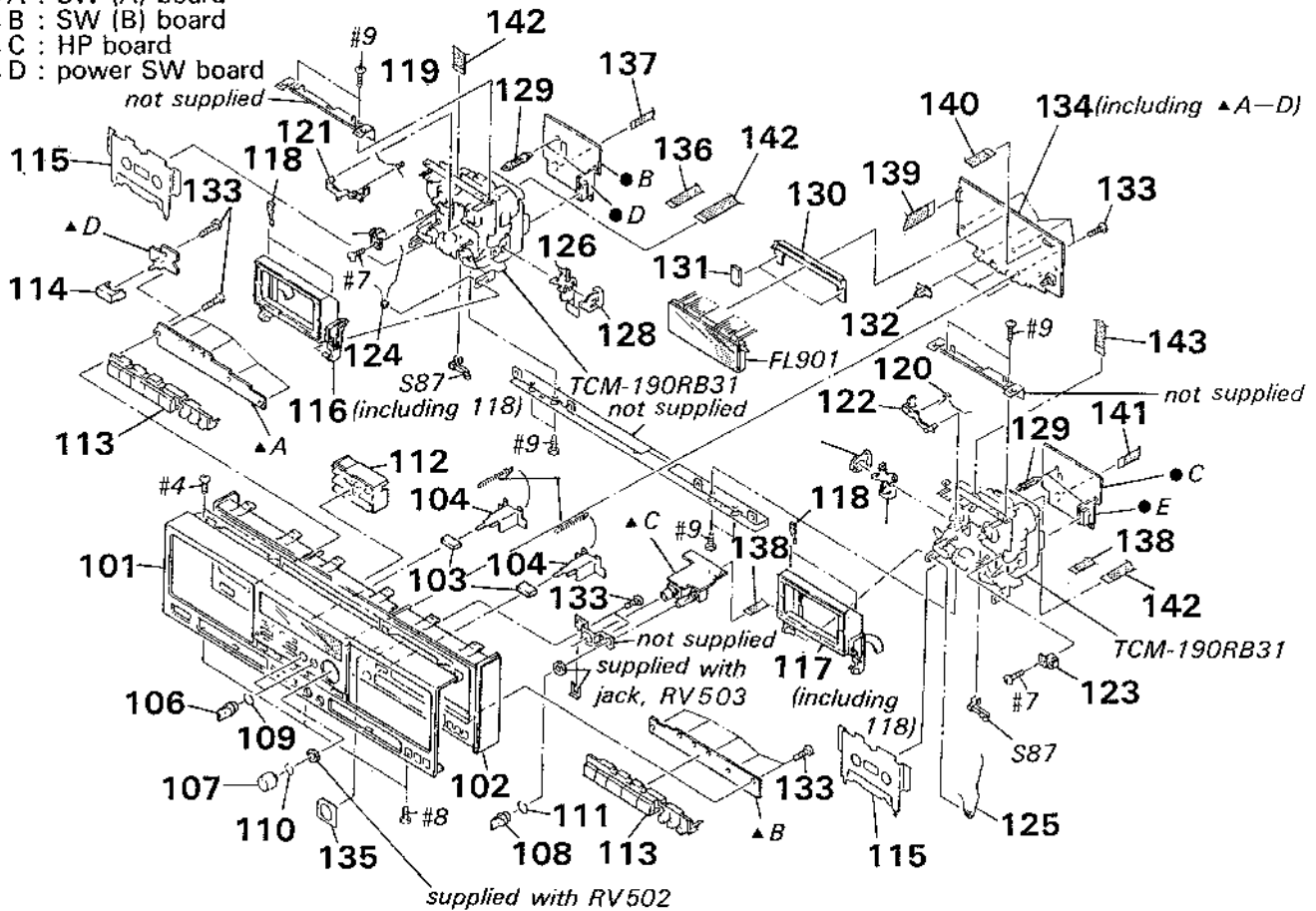

Ref. No.	Part No.	Description	Remark	Ref. No.	Part No.	Description	Remark
101	A-2003-820-A	PANEL ASSY, FRONT (WR87ES)		123	3-354-963-01	DAMPER	
102	3-354-916-12	PANEL (BASE) (WR87ES)		124	3-354-960-01	SPRING (LOADING R), TORSION	
103	3-359-907-01	BUTTON (EJECT) (WR87ES)		125	3-354-959-01	SPRING (LOADING L), TORSION	
104	* 3-359-935-01	LEVER (EJECT) (WR87ES)		126	* 3-354-954-01	LEVER (LOCK LEVER R)	
105	3-362-234-01	SPRING, TENSION (WR87ES)		127	* 3-354-953-01	LEVER (LOCK LEVER L)	
106	3-354-931-11	KNOB (DIA. 10) (WR87ES)		128	3-354-957-01	JOINT (LOCK LEVER)	
107	3-359-932-01	KNOB (REC) (WR87ES)		129	* 3-682-419-21	HOLDER, P. C. B	
108	3-354-931-01	KNOB (DIA. 10) (WR87ES)		130	3-365-420-01	HOLDER, FL TUBE	
109	3-354-981-01	SPRING (SUS), RING (WR87ES)		131	9-911-844-XX	CUSHION (WR87ES)	
110	3-362-235-01	SPRING (REC LEVEL), RING (WR87ES)		132	4-922-518-01	KNOB (TIMER) (WR87ES)	
111	3-356-935-01	SPRING (WR87ES)		133	4-928-635-01	SCREW, +BV (2.6X8) TAPPING	
112	3-354-938-21	BUTTON (B) (WR87ES)		134	* A-2006-512-A	PANEL BOARD, COMPLETE (WR87ES)	
113	3-365-419-01	BUTTON (A) (WR87ES)		135	3-354-923-01	PLATE (VOL), ORNAMENTAL (WR87ES)	
114	3-354-932-01	BUTTON (POWER)		136	* 1-575-847-11	WIRE, FLAT TYPE (5 CORE)	
115	X-3346-313-1	RETAINER ASSY, CASSETTE (WR87ES)		137	* 1-575-851-11	WIRE, FLAT TYPE (7 CORE)	
116	X-3340-195-1	HOLDER (R) ASSY, CASSETTE		138	* 1-575-848-11	WIRE, FLAT TYPE (5 CORE)	
117	X-3340-194-1	HOLDER (L) ASSY, CASSETTE		139	* 1-575-853-11	WIRE, FLAT TYPE (15 CORE)	
118	3-308-823-11	SPRING		140	1-534-517-00	WIRE, FLAT TYPE (11 CORE)	
119	3-354-962-01	SPRING (EJ SAFTY SPRING R)		141	* 1-575-780-11	WIRE, FLAT TYPE (7 CORE)	
120	3-354-961-01	SPRING (EJ SAFTY SPRING L)		142	* 1-575-850-11	WIRE, FLAT TYPE (9 CORE)	
121	3-354-956-01	LEVER (EJ SAFTY LEVER R)		143	* 1-575-781-11	WIRE, FLAT TYPE (9 CORE)	
122	3-354-955-01	LEVER (EJ SAFTY LEVER L)		FL901	1-519-594-11	INDICATOR TUBE, FLUORESCENT	
				S87	1-572-393-11	SWITCH, LEAF (DIRECTION)	

6-4. MECHANISM SECTION-1

(TC-WR775 : TCM-190RB12)
 (TC-WR87ES : TCM-190RB31)

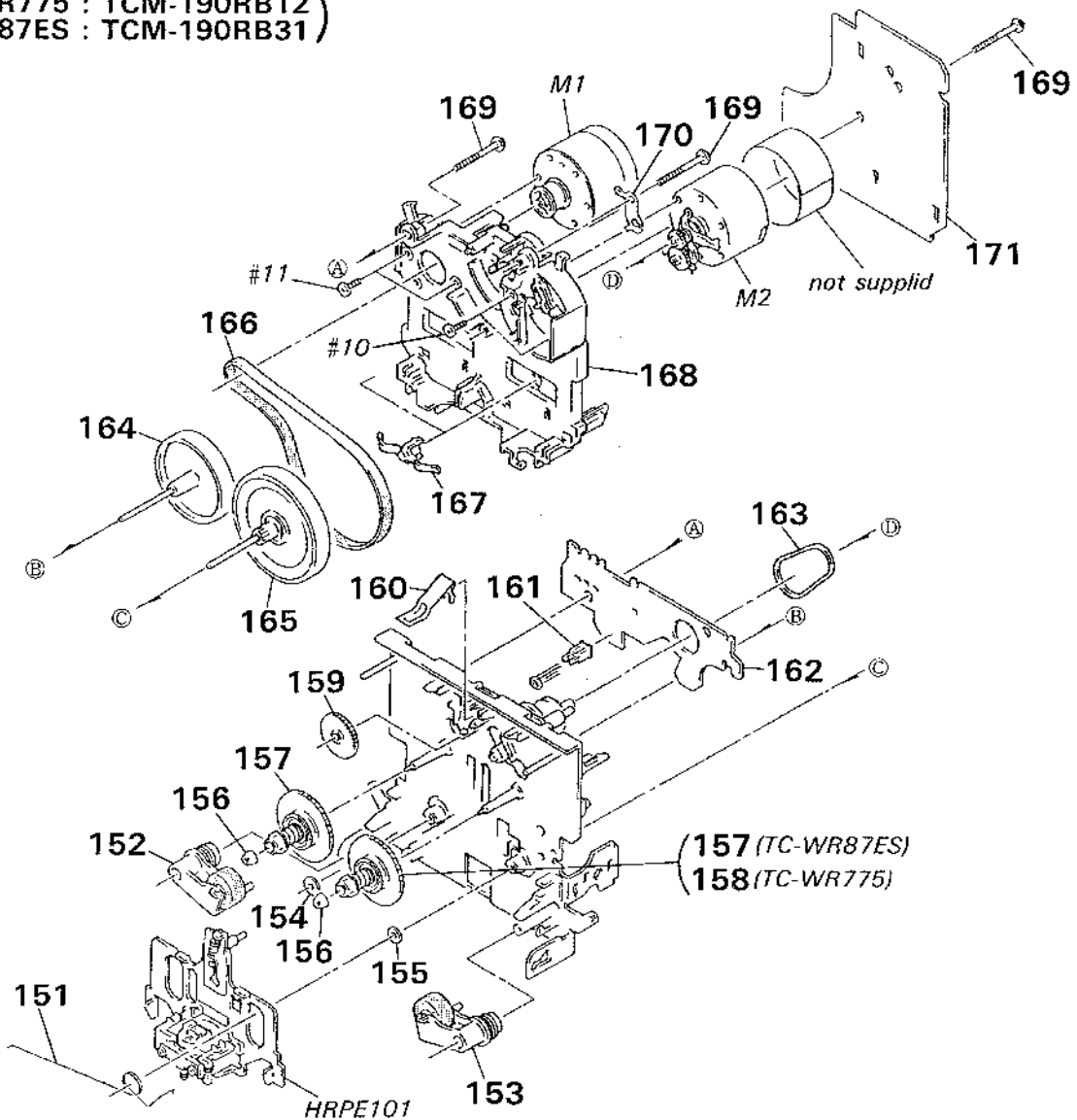

Ref. No.	Part No.	Description	Remark	Ref. No.	Part No.	Description	Remark
151	3-359-455-01	SPRING, TORSION		164	X-3359-410-1	FLYWHEEL (REV) ASSY	
152	X-3359-409-1	LEVER (PINCH LEVER REV) ASSY		165	X-3359-406-1	FLYWHEEL (FWD) COMPLETE ASSY	
153	X-3359-408-1	LEVER (PINCH LEVER FWD) ASSY		166	3-359-417-01	BELT (FLAT), CAPSTAN	
154	3-356-714-01	WASHER		167	3-575-321-00	RETAINER, THRUST, CAPSTAN	
155	3-356-713-01	WASHER		168	* 3-359-436-01	BASE (THRUST RETAINER), FITTING	
156	3-362-308-01	CAP (REEL)		169	3-359-414-01	SCREW (+PTPHW 2X23)	
157	X-3362-078-1	TABLE ASSY (B), REEL (WR87ES)		170	3-359-450-01	PLATE, GROUND	
158	X-3359-404-1	TABLE ASSY, REEL (WR775)		171	* 1-634-842-11	MO-C BOARD	
159	3-359-424-01	GEAR (REV GEAR)		HRPE101	A-2003-420-A	BASE ASSY, HEAD (REC/PB/ERASE) (WR87ES)	
160	3-359-430-01	SPRING (CASSETTE RETAINER), LEAF		HRPE101	A-2003-477-A	BASE ASSY, HEAD (REC/PB/ERASE) (WR775)	
161	3-343-419-01	HOLDER (S SENSER A)		M1	X-3359-417-1	MOTOR ASSY (CAPSTAN)	
162	* 1-634-841-11	SW-A BOARD		M2	A-2003-474-A	MOTOR ASSY (REEL)	
163	3-359-456-01	BELT (FR), SQUARE					

6-5. MECHANISM SECTION-2

(TC-WR775 : TCM-190RB12)
 (TC-WR87ES : TCM-190RB31)

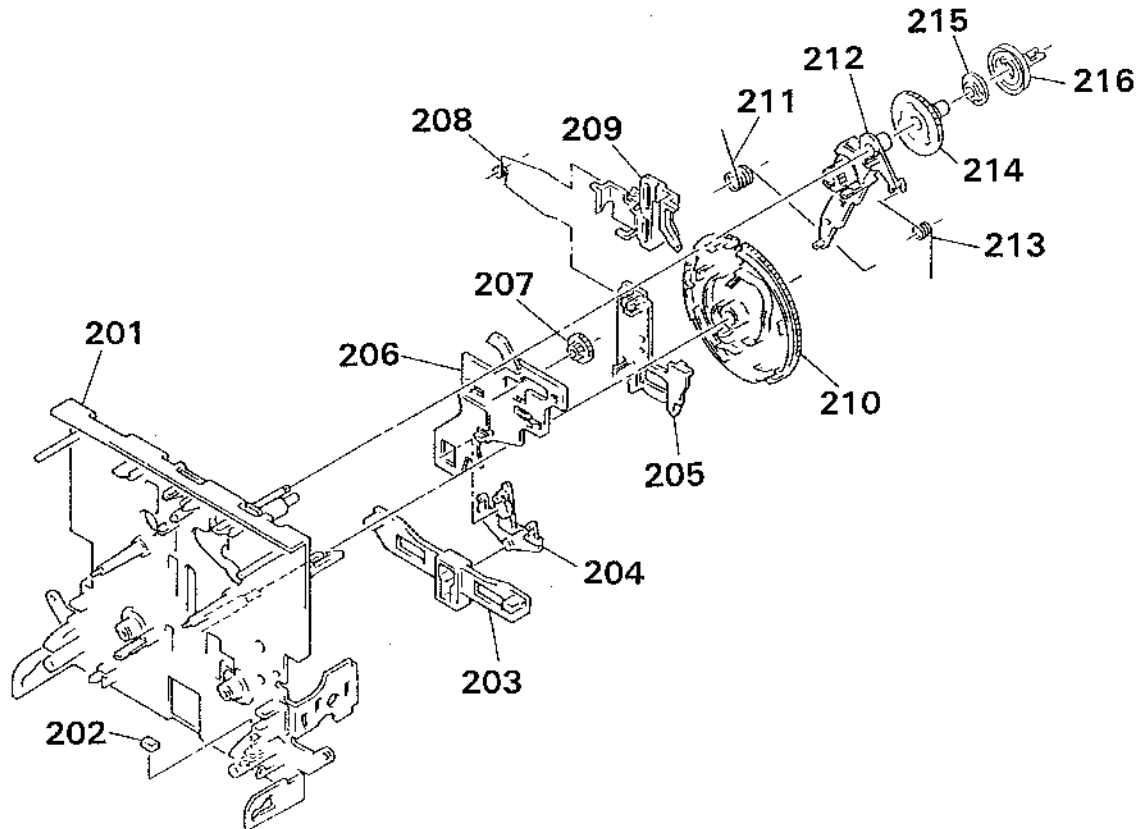

Ref.No.	Part No.	Description	Remark	Ref.No.	Part No.	Description	Remark
201	X-3359-415-1	CHASSIS ASSY, MECHANICAL		210	3-359-420-01	GEAR (CAM GEAR)	
202	3-359-469-01	SPACER		211	3-359-456-01	SPRING (TRIGGER SPRING), TORSION	
203	* 3-359-425-01	SLIDER (REVERSE SLIDER)		212	X-3359-405-1	LEVER (FR ARM) ASSY	
204	3-359-426-01	LEVER (REVERSE LEVER)		213	3-359-453-01	SPRING (FR ARM), TORSION	
205	* 3-359-427-01	SLIDER (LEVERSE SLIDER)		214	3-359-419-01	GEAR (FR GEAR)	
206	* 3-359-415-01	SLIDER (TRIGGER SLIDER)		215	3-359-421-01	CLUTCH (REEL DISK)	
207	3-359-448-01	GEAR (TRIGGER)		216	3-359-418-01	PULLEY (FR PULLEY)	
208	3-359-454-01	SPRING, TORSION					
209	3-359-429-01	SLIDER (BRAKE PLATE)					

SECTION 7 ELECTRICAL PARTS LIST

MD-C

NOTE:

- Due to standardization, replacements in the parts list may be different from the parts specified in the diagrams or the components used on the set.
- Items marked "*" are not stocked since they are seldom required for routine service. Some delay should be anticipated when ordering these items.
- -XX, -X mean standardized parts, so they may have some differences from the original one.
- RESISTORS

All resistors are in ohms
 METAL: Metal-film resistor
 METAL OXIDE: Metal Oxide-film resistor
 F: nonflammable

- SEMICONDUCTORS
 In each case, μ : μ , for example:
 $\mu A \dots : \mu A \dots$, $\mu P A \dots : \mu P A \dots$,
 $\mu P B \dots : \mu P B \dots$, $\mu P C \dots : \mu P C \dots$,
 $\mu P D \dots : \mu P D \dots$
- CAPACITORS
 $\mu F : \mu F$
- COILS
 $\mu H : \mu H$
- WR775 : TC-WR775
 WR87ES : TC-WR87ES

When indicating parts by reference number, please include the board name.

The components identified by mark or dotted line with mark are critical for safety. Replace only with part number specified.

Les composants identifiés par une marque sont critiques pour la sécurité. Ne les remplacer que par une pièce portant le numéro spécifié.

Ref. No.	Part No.	Description	Remark	Ref. No.	Part No.	Description	Remark
	1-834-842-11	MD-C BOARD *****					
< CAPACITOR >				< DIODE >			
C11	1-110-342-11	MYLAR	390PF 5% 50V (WR775)	D31	8-719-107-94	DIODE 1SS202-1	
C11	1-130-469-00	MYLAR	680PF 5% 50V (WR87ES)	< IC >			
C12	1-136-157-00	FILM	0.022 μ F 5% 50V	IC31	8-759-111-44	IC μ PC4570C-1	
C13	1-124-282-00	ELECT	22 μ F 20% 25V	< TRANSISTOR >			
C21	1-110-342-11	MYLAR	390PF 5% 50V (WR775)	Q51	8-729-194-57	TRANSISTOR 2SC945-P	
C21	1-130-469-00	MYLAR	680PF 5% 50V (WR87ES)	Q52	8-729-194-57	TRANSISTOR 2SC945-P	
C22	1-136-157-00	FILM	0.022 μ F 5% 50V (WR775)	Q53	8-729-801-84	TRANSISTOR 2SB1013-34	
C23	1-124-282-00	ELECT	22 μ F 20% 25V	Q71	8-729-820-16	TRANSISTOR 2SA1317-S	
C31	1-124-443-00	ELECT	100 μ F 20% 10V	< RESISTOR >			
C32	1-124-443-00	ELECT	100 μ F 20% 10V	R11	1-247-881-00	CARBON 120K 5% 1/4W (WR775)	
C33	1-124-119-00	ELECT	330 μ F 20% 16V	R11	1-249-435-11	CARBON 33K 5% 1/4W (WR87ES)	
C51	1-136-230-00	FILM	0.0022 μ F 5% 100V	R12	1-249-404-00	CARBON 82 5% 1/4W (WR87ES)	
C52	1-136-230-00	FILM	0.0022 μ F 5% 100V	R12	1-249-405-11	CARBON 100 5% 1/4W (WR775)	
C53	1-130-856-00	FILM	0.0068 μ F 5% 100V	R13	1-247-882-11	CARBON 130K 5% 1/4W	
C54	1-136-558-11	FILM	0.0039 μ F 5% 630V (WR87ES)	R14	1-249-426-11	CARBON 5.6K 5% 1/4W	
C54	1-136-601-11	FILM	0.01 μ F 5% 630V (WR775)	R21	1-247-881-00	CARBON 120K 5% 1/4W (WR775)	
C55	1-161-494-00	CERAMIC	0.022 μ F 25V	R21	1-249-435-11	CARBON 33K 5% 1/4W (WR87ES)	
C56	1-126-157-11	ELECT	10 μ F 20% 16V	R22	1-249-404-00	CARBON 82 5% 1/4W (WR87ES)	
C71	1-124-907-11	ELECT	10 μ F 20% 50V	R22	1-249-405-11	CARBON 100 5% 1/4W (WR775)	
C72	1-124-907-11	ELECT	10 μ F 20% 50V	R23	1-247-882-11	CARBON 130K 5% 1/4W	
< CONNECTOR >				R24	1-249-426-11	CARBON 5.6K 5% 1/4W	
CNP31	* 1-568-824-11	SOCKET, CONNECTOR 5P		R31	1-249-409-11	CARBON 220 5% 1/4W	
CNP32	* 1-564-709-11	PIN, CONNECTOR (SMALL TYPE) 7P		R32	1-249-409-11	CARBON 220 5% 1/4W	
CNP34	* 1-565-344-11	PIN, CONNECTOR (PC BOARD) 8P					
CNP71	* 1-564-705-11	PIN, CONNECTOR (SMALL TYPE) 3P					
CNP72	* 1-564-706-11	PIN, CONNECTOR (SMALL TYPE) 4P					

MD-C SW-A PANEL
 INCLUDING SW(A), SW(B), HP, POWER SW, FL

Ref. No.	Part No.	Description	Remark
R51	1-249-437-11	CARBON 47K 5% 1/4W (WR87ES)	
R51	1-249-441-11	CARBON 100K 5% 1/4W (WR775)	
R52	1-249-437-11	CARBON 47K 5% 1/4W (WR87ES)	
R52	1-249-441-11	CARBON 100K 5% 1/4W (WR775)	
R53	1-249-429-11	CARBON 10K 5% 1/4W	
R54	△ 1-212-849-00	FUSIBLE 4.7 5% 1/4W F (WR87ES)	
R54	△ 1-212-851-00	FUSIBLE 5.6 5% 1/4W F (WR775)	
R55	1-249-429-11	CARBON 10K 5% 1/4W	
R71	1-247-864-11	CARBON 24K 5% 1/4W	
R72	1-249-433-11	CARBON 22K 5% 1/4W	
R73	1-249-437-11	CARBON 47K 5% 1/4W	
R74	1-249-437-11	CARBON 47K 5% 1/4W	
< VARIABLE RESISTOR >			
RV11	1-238-597-11	RES. ADJ. CARBON 1K	
RV21	1-238-597-11	RES. ADJ. CARBON 1K	
RV71	1-238-600-11	RES. ADJ. CARBON 10K	
RV72	1-238-600-11	RES. ADJ. CARBON 10K	
< RELAY >			
RY31	1-515-726-11	RELAY	
< TRANSFORMER >			
T51	1-433-366-11	TRANSFORMER, BIAS OSCILLATION	

* 1-634-841-11 SW-A BOARD			

3-343-419-C1 HOLDER (S SENSER A)			
< CONNECTOR >			
CNP81	* 1-568-852-11	SOCKET, CONNECTOR 9P	
< IC >			
IC81	8-719-710-03	PHOTO SENSOR NJL5165K-B	
IC82	8-719-710-03	PHOTO SENSOR NJL5165K-B (WR87ES)	
< RESISTOR >			
R81	1-249-414-11	CARBON 560 5% 1/4W	
R82	1-247-818-11	CARBON 300 5% 1/4W	
R83	1-247-834-11	CARBON 1.3K 5% 1/4W	
R84	1-249-417-11	CARBON 1K 5% 1/4W	
R85	1-249-408-11	CARBON 180 5% 1/4W	
R86	1-249-408-11	CARBON 180 5% 1/4W (WR87ES)	

Ref. No.	Part No.	Description	Remark
< SWITCH >			
S81	1-571-958-11	SWITCH, PUSH (1 KEY) (STOP)	
S82	1-571-281-21	SWITCH, LEAF (CrO2)	
S83	1-571-281-21	SWITCH, LEAF (METAL)	
S84	1-571-281-21	SWITCH, LEAF (ERASE PROOF A)	
S85	1-571-281-21	SWITCH, LEAF (ERASE PROOF B)	
S86	1-571-281-21	SWITCH, LEAF (HALF)	

* A-2006-512-A PANEL BOARD, COMPLETE (INCLUDING SW(A), SW(B), HP, POWER SW BOARD) (WR87ES)			
* A-2006-518-A PANEL BOARD, COMPLETE (INCLUDING FL, HP BOARD) (WR775)			

9-911-844-XX CUSHION			
3-385-420-01 HOLDER, FL TUBE			
< CAPACITOR >			
C901	1-164-159-11	CERAMIC 0.1uF 50V	
C902	1-124-443-11	ELECT 100uF 20% 6.3V (WR87ES)	
C902	1-128-340-91	ELECT 100uF 20% 6.3V (WR775)	
C903	1-164-159-11	CERAMIC 0.1uF 50V	
< CONNECTOR >			
CN901	* 1-568-334-11	SOCKET, CONNECTOR 15P (WR87ES)	
CN901	* 1-568-858-11	SOCKET, CONNECTOR 15P (WR775)	
CN902	* 1-568-830-11	SOCKET, CONNECTOR 11P	
CN904	* 1-564-498-11	PIN, CONNECTOR 5P (WR87ES)	
CN905	* 1-564-498-11	PIN, CONNECTOR 5P (WR87ES)	
CN906	* 1-564-498-11	PIN, CONNECTOR 5P (WR87ES)	
< CIRCUIT BLOCK >			
CP901	1-232-946-11	COMPOSITION CIRCUIT BLOCK (10KX4)	
CP902	1-239-059-11	COMPOSITION CIRCUIT BLOCK (2.2KX4)	
CP903	1-233-199-11	COMPOSITION CIRCUIT BLOCK (10KX8)	
CP904	1-239-060-11	COMPOSITION CIRCUIT BLOCK (100KX8)	
< FLUORESCENT INDICATOR >			
FL901	1-519-594-11	INDICATOR TUBE, FLUORESCENT	
< IC >			
IC901	8-759-636-52	IC M50941-581SP (WR87ES)	
IC901	8-759-636-78	IC M50941-580SP (WR775)	
IC902	8-741-100-48	IC SBX1610-59	

<p>Note: The components identified by mark △ or dotted line with mark △ are critical for safety. Replace only with part number specified.</p>	<p>Note: Les composants identifiés par une marque △ sont critiques pour la sécurité. Ne les remplacer que par une pièce portant le numéro spécifié.</p>
---	--

PANEL

INCLUDING SW(A), SW(B), HP, POWER SW, FL

Ref. No.	Part No.	Description	Remark	Ref. No.	Part No.	Description	Remark
		< JACK >					
J501	1-507-796-71	JACK (PHONES)		R942	1-249-417-11	CARBON 1K 5% 1/4W	
		< TRANSISTOR >		R943	1-249-420-11	CARBON 1.8K 5% 1/4W	
Q901	8-729-900-65	TRANSISTOR DTA144ES		R944	1-249-424-11	CARBON 3.9K 5% 1/4W	
Q902	8-729-620-05	TRANSISTOR 2SC2603-EF		R945	1-249-430-11	CARBON 12K 5% 1/4W	
Q903	8-729-620-05	TRANSISTOR 2SC2603-EF		R946	1-249-407-11	CARBON 150 5% 1/4W	
Q904	8-729-900-74	TRANSISTOR DTC143TS		R950	1-249-430-11	CARBON 12K 5% 1/4W (WR87ES)	
Q905	8-729-900-65	TRANSISTOR DTA144ES		R951	1-249-429-11	CARBON 10K 5% 1/4W (WR87ES)	
Q906	8-729-900-65	TRANSISTOR DTA144ES				< VARIABLE RESISTOR >	
Q907	8-729-620-05	TRANSISTOR 2SC2603-EF		RV501	1-241-503-11	RES. VAR. CARBON 50K/50K (BALANCE)	
Q908	8-729-620-05	TRANSISTOR 2SC2603-EF		RV502	1-241-502-11	RES. VAR. CARBON 50K/50K (REC LEVEL)	
Q909	8-729-620-05	TRANSISTOR 2SC2603-EF		RV901	1-241-134-11	RES. VAR. CARBON 20K (BIAS) (WR87ES)	
		< RESISTOR >				< SWITCH >	
R901	1-247-903-00	CARBON 1M 5% 1/4W		S901	1-554-303-21	SWITCH, TACTILE (HIGH SPEED SYNCHRO DUBBING)	
R902	1-249-417-11	CARBON 1K 5% 1/4W		S902	1-554-303-21	SWITCH, TACTILE (NORM SPEED SYNCHRO DUBBING)	
R903	1-249-437-11	CARBON 47K 5% 1/4W		S903	1-554-303-21	SWITCH, TACTILE (REC A+B)	
R904	1-249-430-11	CARBON 12K 5% 1/4W		S904	1-554-303-21	SWITCH, TACTILE (AUTO PAUSE)	
R905	1-247-887-00	CARBON 220K 5% 1/4W		S905	1-554-303-21	SWITCH, TACTILE (BLANK SKIP)	
R906	1-247-887-00	CARBON 220K 5% 1/4W		S906	1-554-303-21	SWITCH, TACTILE (RESET A)	
R907	1-247-887-00	CARBON 220K 5% 1/4W		S908	1-554-303-21	SWITCH, TACTILE (RESET B)	
R908	1-247-887-00	CARBON 220K 5% 1/4W		S909	1-554-303-21	SWITCH, TACTILE (MEMORY)	
R909	1-249-433-11	CARBON 22K 5% 1/4W		S910	1-554-303-21	SWITCH, TACTILE (STOP A)	
R910	1-249-424-11	CARBON 3.9K 5% 1/4W		S911	1-554-303-21	SWITCH, TACTILE (FWD A)	
R911	1-249-437-11	CARBON 47K 5% 1/4W		S912	1-554-303-21	SWITCH, TACTILE (REV A)	
R912	1-249-437-11	CARBON 47K 5% 1/4W		S913	1-554-303-21	SWITCH, TACTILE (PAUSE A)	
R921	1-249-407-11	CARBON 150 5% 1/4W		S914	1-554-303-21	SWITCH, TACTILE (REC MUTE A)	
R922	1-249-409-11	CARBON 220 5% 1/4W		S915	1-554-303-21	SWITCH, TACTILE (REW A)	
R923	1-249-411-11	CARBON 330 5% 1/4W		S916	1-554-303-21	SWITCH, TACTILE (FF A)	
R924	1-249-413-11	CARBON 470 5% 1/4W		S917	1-554-303-21	SWITCH, TACTILE (REC A)	
R925	1-249-415-11	CARBON 680 5% 1/4W		S918	1-554-303-21	SWITCH, TACTILE (STOP B)	
R926	1-249-417-11	CARBON 1K 5% 1/4W		S919	1-554-303-21	SWITCH, TACTILE (FWD B)	
R927	1-249-420-11	CARBON 1.8K 5% 1/4W		S920	1-554-303-21	SWITCH, TACTILE (REV B)	
R928	1-249-424-11	CARBON 3.9K 5% 1/4W		S921	1-554-303-21	SWITCH, TACTILE (PAUSE B)	
R929	1-249-407-11	CARBON 150 5% 1/4W		S922	1-554-303-21	SWITCH, TACTILE (REC MUTE B)	
R930	1-249-409-11	CARBON 220 5% 1/4W		S923	1-554-303-21	SWITCH, TACTILE (REW B)	
R931	1-249-411-11	CARBON 330 5% 1/4W		S924	1-554-303-21	SWITCH, TACTILE (FF B)	
R932	1-249-413-11	CARBON 470 5% 1/4W		S925	1-554-303-21	SWITCH, TACTILE (REC B)	
R933	1-249-415-11	CARBON 680 5% 1/4W		S926	1-571-520-11	SWITCH, SLIDE (DIRECTION) (WR87ES)	
R934	1-249-417-11	CARBON 1K 5% 1/4W		S926	1-572-401-11	SWITCH, SLIDE (DIRECTION) (WR775)	
R935	1-249-420-11	CARBON 1.8K 5% 1/4W		S927	1-571-520-11	SWITCH, SLIDE (B DECK DOLBY) (WR87ES)	
R936	1-249-424-11	CARBON 3.9K 5% 1/4W (WR87ES)		S927	1-572-401-11	SWITCH, SLIDE (B DECK DOLBY) (WR775)	
R937	1-249-407-11	CARBON 150 5% 1/4W		S928	1-571-520-11	SWITCH, SLIDE (TIMER OFF) (WR87ES)	
R938	1-249-409-11	CARBON 220 5% 1/4W					
R939	1-249-411-11	CARBON 330 5% 1/4W					
R940	1-249-413-11	CARBON 470 5% 1/4W					
R941	1-249-415-11	CARBON 680 5% 1/4W					

PANEL

INCLUDING SW(A), SW(B), HP, POWER SW, FL

SYSTEM CONTROL

INCLUDING HX PRO(A), HX PRO(B), TRANSLATION(A), TRANSLATION(B), MPX, POWER SW

Ref. No.	Part No.	Description	Remark	Ref. No.	Part No.	Description	Remark
		< CERAMIC >					
X901	1-577-358-21	VIBRATOR, CERAMIC (4MHZ)		C221	1-124-907-11	ELECT	10uF 20% 50V
*****				C222	1-124-907-11	ELECT	10uF 20% 50V
* A-2006-511-A	SYSTEM CONTROL BOARD, COMPLETE (INCLUDING HX PRO (A), HX PRO (B), TRANSLATION (A), TRANSLATION (B), MPX BOARD) (WR87ES)			C224	1-124-902-00	ELECT	0.47uF 20% 50V
* A-2006-517-A	SYSTEM CONTROL BOARD, COMPLETE (INCLUDING HX PRO (A), HX PRO (B), TRANSLATION (A), TRANSLATION (B), POWER SW BOARD) (WR775)			C231	1-123-382-00	ELECT	3.3uF 20% 100V
*****				C251	1-124-907-11	ELECT	10uF 20% 50V
* 1-533-213-31	HOLDER, FUSE			C252	1-124-907-11	ELECT	10uF 20% 50V
* 1-533-213-31	HOLDER, FUSE			C254	1-124-902-00	ELECT	0.47uF 20% 50V
7-685-646-79	SCREW +8VTP 3X8 TYPE2 SLIT			C281	1-126-096-11	ELECT	10uF 20% 25V (WR87ES)
7-682-547-04	SCREW +BVTT 3X6 (S)			C391	1-136-273-91	FILM	75PF 5% 630V (WR775)
*****				C391	1-136-935-11	FILM	22PF 5% 630V (WR87ES)
< CAPACITOR >				C392	1-162-285-31	CERAMIC	180PF 10% 50V (WR87ES)
C101	1-136-157-00	FILM	0.022uF 5% 50V	C392	1-162-288-31	CERAMIC	330PF 10% 50V (WR775)
C102	1-162-294-31	CERAMIC	0.001uF 10% 50V	C393	1-130-468-00	MYLAR	560PF 5% 50V (WR87ES)
C103	1-161-375-00	CERAMIC	0.0022uF 20% 50V	C393	1-130-472-00	MYLAR	0.0012uF 5% 50V (WR775)
C104	1-130-475-00	MYLAR	0.0022uF 5% 50V	C394	1-136-433-11	FILM	100PF 5% 630V
C105	1-130-475-00	MYLAR	0.0022uF 5% 50V	C395	1-136-272-00	FILM	68PF 5% 630V (WR87ES)
C106	1-136-174-00	FILM	0.56uF 5% 50V	C395	1-136-437-11	FILM	220PF 5% 630V (WR775)
C107	1-136-171-00	FILM	0.33uF 5% 50V	C396	1-136-165-00	FILM	0.1uF 5% 50V
C108	1-124-907-11	ELECT	10uF 20% 50V	C397	1-136-157-00	FILM	0.022uF 5% 50V
C109	1-124-126-00	ELECT	47uF 20% 10V	C398	1-136-153-00	FILM	0.01uF 5% 50V
C110	1-124-907-11	ELECT	10uF 20% 50V	C491	1-136-273-91	FILM	75PF 5% 630V (WR775)
C111	1-124-903-11	ELECT	1uF 20% 50V	C491	1-136-935-11	FILM	22PF 5% 630V (WR87ES)
C121	1-124-907-11	ELECT	10uF 20% 50V	C492	1-162-285-31	CERAMIC	180PF 10% 50V (WR87ES)
C122	1-124-907-11	ELECT	10uF 20% 50V	C492	1-162-288-31	CERAMIC	330PF 10% 50V (WR775)
C124	1-124-902-00	ELECT	0.47uF 20% 50V	C493	1-130-468-00	MYLAR	560PF 5% 50V (WR87ES)
C131	1-123-382-00	ELECT	3.3uF 20% 100V	C493	1-130-472-00	MYLAR	0.0012uF 5% 50V (WR775)
C151	1-124-907-11	ELECT	10uF 20% 50V	C494	1-136-433-11	FILM	100PF 5% 630V
C152	1-124-907-11	ELECT	10uF 20% 50V	C495	1-136-272-00	FILM	68PF 5% 630V (WR87ES)
C154	1-124-902-00	ELECT	0.47uF 20% 50V	C495	1-136-437-11	FILM	220PF 5% 630V (WR775)
C181	1-126-096-11	ELECT	10uF 20% 25V (WR87ES)	C496	1-136-165-00	FILM	0.1uF 5% 50V
C201	1-136-157-00	FILM	0.022uF 5% 50V	C497	1-136-157-00	FILM	0.022uF 5% 50V
C202	1-162-294-31	CERAMIC	0.001uF 10% 50V	C498	1-136-153-00	FILM	0.01uF 5% 50V
C203	1-161-375-00	CERAMIC	0.0022uF 20% 50V	C506	1-124-903-11	ELECT	1uF 20% 50V
C204	1-130-475-00	MYLAR	0.0022uF 5% 50V	C542	1-124-925-11	ELECT	2.2uF 20% 100V
C205	1-130-475-00	MYLAR	0.0022uF 5% 50V	C591	1-126-927-11	ELECT	2200uF 20% 10V
C206	1-136-174-00	FILM	0.56uF 5% 50V	C592	1-124-589-11	ELECT	47uF 20% 16V (WR87ES)
C207	1-136-171-00	FILM	0.33uF 5% 50V	C593	1-124-589-11	ELECT	47uF 20% 16V (WR87ES)
C208	1-124-907-11	ELECT	10uF 20% 50V	C599	1-124-925-11	ELECT	2.2uF 20% 100V
C209	1-124-126-00	ELECT	47uF 20% 10V	C601	1-124-925-11	ELECT	2.2uF 20% 100V
C210	1-124-907-11	ELECT	10uF 20% 50V	C602	1-162-286-31	CERAMIC	220PF 10% 50V
C211	1-124-903-11	ELECT	1uF 20% 50V	C603	1-162-286-31	CERAMIC	220PF 10% 50V
				C604	1-124-925-11	ELECT	2.2uF 20% 100V
				C605	1-136-157-00	FILM	0.022uF 5% 50V

SYSTEM CONTROL

INCLUDING HX PRO(A), HX PRO(B), TRANSLATION(A), TRANSLATION(B), MPX, POWER SW

Ref. No.	Part No.	Description	Remark			Ref. No.	Part No.	Description	Remark		
C608	1-124-925-11	ELECT	2.2uF	20%	100V	C0494	1-136-433-11	FILM	100PF	5%	630V
C691	1-107-046-00	MICA	4.7PF		500V	C0495	1-136-272-00	FILM	68PF	5%	630V (WR87ES)
C692	1-124-126-00	ELECT	47uF	20%	10V	C0495	1-136-437-11	FILM	220PF	5%	630V (WR775)
C693	1-126-101-11	ELECT	100uF	20%	16V	C0496	1-136-165-00	FILM	0.1uF	5%	50V
C694	1-124-902-00	ELECT	0.47uF	20%	50V	C0497	1-136-157-00	FILM	0.022uF	5%	50V
C701	1-124-443-00	ELECT	100uF	20%	10V	C0498	1-136-153-00	FILM	0.01uF	5%	50V
C702	1-124-122-11	ELECT	100uF	20%	50V	C0691	1-107-046-00	MICA	4.7PF		500V
C703	1-124-925-11	ELECT	2.2uF	20%	100V	C0692	1-124-126-00	ELECT	47uF	20%	10V
C704	1-124-911-11	ELECT	220uF	20%	50V	C0693	1-126-101-11	ELECT	100uF	20%	16V
C705	1-124-927-11	ELECT	4.7uF	20%	100V	C0694	1-124-902-00	ELECT	0.47uF	20%	50V
C707	1-124-925-11	ELECT	2.2uF	20%	100V	< CONNECTOR >					
C708	1-124-564-11	ELECT	4700uF	20%	25V	CN501	* 1-568-824-11	SOCKET, CONNECTOR	5P		
C709	1-124-126-00	ELECT	47uF	20%	10V	CN502	* 1-568-824-11	SOCKET, CONNECTOR	5P		
C710	1-126-927-11	ELECT	2200uF	20%	10V	CN503	* 1-568-826-11	SOCKET, CONNECTOR	7P		
C711	1-126-927-11	ELECT	2200uF	20%	10V	CN504	* 1-568-826-11	SOCKET, CONNECTOR	7P		
C712	1-126-946-11	ELECT	6800uF	20%	25V	CN505	* 1-564-337-00	PIN, CONNECTOR	3P (WR775)		
C713	1-161-494-00	CERAMIC	0.022uF		25V	CN505	* 1-568-824-11	SOCKET, CONNECTOR	5P (WR87ES)		
C801	1-124-443-00	ELECT	100uF	20%	10V	CN506	* 1-568-848-11	SOCKET, CONNECTOR	5P (WR87ES)		
C802	1-164-159-11	CERAMIC	0.1uF		50V	CN601	* 1-564-509-11	PLUG, CONNECTOR	6P		
C803	1-164-159-11	CERAMIC	0.1uF		50V	CN691	* 1-568-826-11	SOCKET, CONNECTOR	7P		
C804	1-124-443-00	ELECT	100uF	20%	10V	CN701	* 1-564-338-00	PIN, CONNECTOR	4P (WR87ES)		
C805	1-124-925-11	ELECT	2.2uF	20%	100V	CN701	* 1-564-339-00	PIN, CONNECTOR	5P (WR775)		
C806	1-136-165-00	FILM	0.1uF	5%	50V	CN703	* 1-564-510-11	PLUG, CONNECTOR	7P		
C807	1-136-165-00	FILM	0.1uF	5%	50V	CN801	* 1-568-830-11	SOCKET, CONNECTOR	11P		
C851	1-124-902-00	ELECT	0.47uF	20%	50V	CN802	* 1-568-828-11	SOCKET, CONNECTOR	9P		
C861	1-162-294-31	CERAMIC	0.001uF	10%	50V	CN803	* 1-568-828-11	SOCKET, CONNECTOR	9P		
C0391	1-136-273-91	FILM	75PF	5%	630V (WR775)	CN804	* 1-568-828-11	SOCKET, CONNECTOR	9P		
C0391	1-136-935-11	FILM	22PF	5%	630V (WR87ES)	CN805	* 1-568-828-11	SOCKET, CONNECTOR	9P		
C0392	1-162-285-31	CERAMIC	180PF	10%	50V (WR87ES)	CN806	* 1-568-834-11	SOCKET, CONNECTOR	15P		
C0392	1-162-288-31	CERAMIC	330PF	10%	50V (WR775)	CN0691	* 1-568-826-11	SOCKET, CONNECTOR	7P		
C0393	1-130-458-00	MYLAR	560PF	5%	50V (WR87ES)	CNP506	* 1-564-505-11	PLUG, CONNECTOR	2P (WR87ES)		
C0393	1-130-472-00	MYLAR	0.0012uF	5%	50V (WR775)	CNP691	* 1-565-347-11	SOCKET, CONNECTOR (PC BOARD)	8P		
C0394	1-136-433-11	FILM	100PF	5%	630V	CNP0691*	1-565-347-11	SOCKET, CONNECTOR (PC BOARD)	8P		
C0395	1-136-272-00	FILM	68PF	5%	630V (WR87ES)	< DIODE >					
C0395	1-136-437-11	FILM	220PF	5%	630V (WR775)	D131	8-719-912-20	DIODE	1SS120		
C0396	1-136-165-00	FILM	0.1uF	5%	50V	D231	8-719-912-20	DIODE	1SS120		
C0397	1-136-157-00	FILM	0.022uF	5%	50V	D501	8-719-912-20	DIODE	1SS120		
C0398	1-136-153-00	FILM	0.01uF	5%	50V	D502	8-719-912-20	DIODE	1SS120		
C0491	1-136-273-91	FILM	75PF	5%	630V (WR775)	D503	8-719-933-54	DIODE	HZS9A2L		
C0491	1-136-935-11	FILM	22PF	5%	630V (WR87ES)	D571	8-719-912-20	DIODE	1SS120		
C0492	1-162-285-31	CERAMIC	180PF	10%	50V (WR87ES)	D572	8-719-001-36	DIODE	UZL-11L2		
C0492	1-162-288-31	CERAMIC	330PF	10%	50V (WR775)	D601	8-719-912-20	DIODE	1SS120		
C0493	1-130-468-00	MYLAR	560PF	5%	50V (WR87ES)	D602	8-719-912-20	DIODE	1SS120		
C0493	1-130-472-00	MYLAR	0.0012uF	5%	50V (WR775)	D701	8-719-000-78	DIODE	HZS7A1L		

SYSTEM CONTROL

INCLUDING HX PRO(A), HX PRO(B), TRANSLATION(A), TRANSLATION(B), MPX, POWER SW

Ref. No.	Part No.	Description	Remark	Ref. No.	Part No.	Description	Remark
D702	8-719-912-20	DIODE 1SS120				< FILTER >	
D703	8-719-200-77	DIODE 10E2N		LPF101	1-231-388-00	FILTER, LOW PASS (WR775)	
D704	8-719-200-77	DIODE 10E2N		LPF101	1-236-147-11	FILTER, LOW PASS (WR87ES)	
D705	8-719-200-77	DIODE 10E2N					
D706	8-719-912-20	DIODE 1SS120		LPF201	1-231-388-00	FILTER, LOW PASS (WR775)	
D707	8-719-200-77	DIODE 10E2N		LPF201	1-236-147-11	FILTER, LOW PASS (WR87ES)	
D708	8-719-200-77	DIODE 10E2N				< TRANSISTOR >	
D709	8-719-933-33	DIODE HZS7A1L		Q101	8-729-900-74	TRANSISTOR DTC143TS	
D710	8-719-200-77	DIODE 10E2N		Q102	8-729-900-74	TRANSISTOR DTC143TS	
D711	8-719-200-77	DIODE 10E2N		Q121	8-729-821-31	TRANSISTOR 2SD1012-FG	
D712	8-719-933-33	DIODE HZS7A1L		Q171	8-729-821-31	TRANSISTOR 2SD1012-FG	
D713	8-719-900-93	DIODE UZL-7H1		Q201	8-729-900-74	TRANSISTOR DTC143TS	
D801	8-719-912-20	DIODE 1SS120		Q202	8-729-900-74	TRANSISTOR DTC143TS	
D811	8-719-912-20	DIODE 1SS120		Q221	8-729-821-31	TRANSISTOR 2SD1012-FG	
D812	8-719-912-20	DIODE 1SS120		Q271	8-729-821-31	TRANSISTOR 2SD1012-FG	
		< IC >		Q501	8-729-900-65	TRANSISTOR DTA144ES	
IC501	8-752-035-94	IC CXA1331S		Q502	8-729-900-65	TRANSISTOR DTA144ES	
IC503	8-759-945-58	IC RC4558P		Q503	8-729-900-65	TRANSISTOR DTA144ES	
IC504	8-759-945-58	IC RC4558P		Q504	8-729-900-65	TRANSISTOR DTA144ES	
IC506	8-759-140-53	IC uPD4053BC		Q505	8-729-900-89	TRANSISTOR DTC144ES	
IC509	8-752-038-02	IC CXA1198AP		Q521	8-729-900-61	TRANSISTOR DTA114ES	
IC510	8-759-208-06	IC TC4051BPHB		Q551	8-729-900-61	TRANSISTOR DTA114ES	
IC511	8-752-038-02	IC CXA1198AP		Q552	8-729-821-31	TRANSISTOR 2SD1012-FG	
IC601	8-759-634-50	IC M5218AL (WR87ES)		Q553	8-729-821-31	TRANSISTOR 2SD1012-FG	
IC601	8-759-634-51	IC M5218AP (WR775)		Q571	8-729-900-65	TRANSISTOR DTA144ES	
IC691	8-759-106-56	IC uPC1297CA		Q572	8-729-821-04	TRANSISTOR 2SA1317-STU	
IC701	8-759-945-58	IC RC4558P		Q601	8-729-900-89	TRANSISTOR DTC144ES	
IC802	8-759-635-94	IC M50925SP-482SP		Q701	8-729-111-55	TRANSISTOR 2SD1312-K	
IC803	8-759-634-84	IC M50255P		Q702	8-729-620-05	TRANSISTOR 2SC2603-EF	
IC804	8-759-240-50	IC TC4050BP		Q703	8-729-821-04	TRANSISTOR 2SA1317-STU	
IC805	8-759-207-05	IC TA7272P		Q704	8-729-924-90	TRANSISTOR 2SB1370-EF	
IC806	8-759-000-48	IC MC14052BCP		Q705	8-729-924-90	TRANSISTOR 2SB1370-EF	
IC807	8-759-000-48	IC MC14052BCP		Q706	8-729-900-85	TRANSISTOR DTC144WS	
IC0691	8-759-106-56	IC uPC1297CA		Q707	8-729-111-55	TRANSISTOR 2SD1312-K	
		< JACK >		Q708	8-729-900-89	TRANSISTOR DTC144ES	
J301	1-565-258-11	JACK, PIN 4P (LINE IN/OUT) (WR775)		Q801	8-729-801-84	TRANSISTOR 2SB1013-3	
J301	1-565-069-11	JACK, PIN 4P (INLE IN/OUT) (WR87ES)		Q802	8-729-801-84	TRANSISTOR 2SB1013-3	
		< COIL >		Q803	8-729-900-61	TRANSISTOR DTA114ES	
L391	1-410-780-11	INDUCTOR 27mH		Q804	8-729-900-80	TRANSISTOR DTC114ES	
L491	1-410-780-11	INDUCTOR 27mH		Q805	8-729-900-61	TRANSISTOR DTA114ES	
L0391	1-410-780-11	INDUCTOR 27mH		Q806	8-729-900-61	TRANSISTOR DTA114ES	
L0491	1-410-780-11	INDUCTOR 27mH		Q807	8-729-821-04	TRANSISTOR 2SA1317-STU	
				Q851	8-729-900-61	TRANSISTOR DTA114ES	
				Q852	8-729-900-89	TRANSISTOR DTC144ES	
				Q853	8-729-900-61	TRANSISTOR DTA114ES	
				Q854	8-729-900-89	TRANSISTOR DTC144ES	
				Q891	8-729-900-61	TRANSISTOR DTA114ES	

SYSTEM CONTROL

INCLUDING HX PRO(A), HX PRO(B), TRANSLATION(A), TRANSLATION(B), MPX, POWER SW

Ref. No.	Part No.	Description	Remark	Ref. No.	Part No.	Description	Remark
< RESISTOR >							
R101	1-249-423-11	CARBON	3.3K 5% 1/4W	R231	1-249-408-11	CARBON	180 5% 1/4W
R102	1-247-887-00	CARBON	220K 5% 1/4W	R232	1-247-870-11	CARBON	43K 5% 1/4W
R103	1-249-441-11	CARBON	100K 5% 1/4W	R233	1-249-421-11	CARBON	2.2K 5% 1/4W
R104	1-249-423-11	CARBON	3.3K 5% 1/4W	R234	1-249-435-11	CARBON	33K 5% 1/4W
R105	1-249-428-11	CARBON	8.2K 5% 1/4W	R251	1-249-425-11	CARBON	4.7K 5% 1/4W
R106	1-247-864-11	CARBON	24K 5% 1/4W	R253	1-249-421-11	CARBON	2.2K 5% 1/4W
R107	1-249-414-11	CARBON	560 5% 1/4W	R255	1-249-426-11	CARBON	5.6K 5% 1/4W
R119	1-249-421-11	CARBON	2.2K 5% 1/4W	R256	1-249-429-11	CARBON	10K 5% 1/4W
R121	1-249-425-11	CARBON	4.7K 5% 1/4W	R271	1-249-433-11	CARBON	22K 5% 1/4W
R124	1-249-426-11	CARBON	5.6K 5% 1/4W	R272	1-249-417-11	CARBON	1K 5% 1/4W
R125	1-249-421-11	CARBON	2.2K 5% 1/4W	R273	1-249-430-11	CARBON	12K 5% 1/4W (WR775)
R126	1-249-429-11	CARBON	10K 5% 1/4W	R273	1-249-431-11	CARBON	15K 5% 1/4W (WR87ES)
R131	1-249-408-11	CARBON	180 5% 1/4W	R274	1-249-421-11	CARBON	2.2K 5% 1/4W
R132	1-247-870-11	CARBON	43K 5% 1/4W	R281	1-249-429-11	CARBON	10K 5% 1/4W (WR775)
R133	1-249-421-11	CARBON	2.2K 5% 1/4W	R281	1-249-433-11	CARBON	22K 5% 1/4W (WR87ES)
R134	1-249-435-11	CARBON	33K 5% 1/4W	R282	1-249-421-11	CARBON	2.2K 5% 1/4W (WR87ES)
R151	1-249-425-11	CARBON	4.7K 5% 1/4W	R283	1-249-433-11	CARBON	22K 5% 1/4W (WR87ES)
R153	1-249-421-11	CARBON	2.2K 5% 1/4W	R284	1-249-405-11	CARBON	100 5% 1/4W (WR775)
R155	1-249-426-11	CARBON	5.6K 5% 1/4W	R284	1-249-409-11	CARBON	220 5% 1/4W (WR87ES)
R156	1-249-429-11	CARBON	10K 5% 1/4W	R291	1-249-420-11	CARBON	1.8K 5% 1/4W
R171	1-249-433-11	CARBON	22K 5% 1/4W	R391	1-249-428-11	CARBON	8.2K 5% 1/4W (WR87ES)
R172	1-249-417-11	CARBON	1K 5% 1/4W	R391	1-249-430-11	CARBON	12K 5% 1/4W (WR775)
R173	1-249-430-11	CARBON	12K 5% 1/4W (WR775)	R392	1-247-883-00	CARBON	150K 5% 1/4W (WR775)
R173	1-249-431-11	CARBON	15K 5% 1/4W (WR87ES)	R392	1-247-884-11	CARBON	160K 5% 1/4W (WR87ES)
R174	1-249-421-11	CARBON	2.2K 5% 1/4W	R393	△ 1-212-857-00	FUSIBLE	10 5% 1/4W F
R181	1-249-429-11	CARBON	10K 5% 1/4W (WR775)	R394	1-249-431-11	CARBON	15K 5% 1/4W (WR775)
R181	1-249-433-11	CARBON	22K 5% 1/4W (WR87ES)	R394	1-249-432-11	CARBON	18K 5% 1/4W (WR87ES)
R182	1-249-421-11	CARBON	2.2K 5% 1/4W (WR87ES)	R395	1-247-854-11	CARBON	9.1K 5% 1/4W (WR87ES)
R183	1-249-433-11	CARBON	22K 5% 1/4W (WR87ES)	R395	1-247-862-11	CARBON	20K 5% 1/4W (WR775)
R184	1-249-405-11	CARBON	100 5% 1/4W (WR775)	R491	1-249-428-11	CARBON	8.2K 5% 1/4W (WR87ES)
R184	1-249-409-11	CARBON	220 5% 1/4W (WR87ES)	R491	1-249-430-11	CARBON	12K 5% 1/4W (WR775)
R191	1-249-420-11	CARBON	1.8K 5% 1/4W	R492	1-247-883-00	CARBON	150K 5% 1/4W (WR775)
R201	1-249-423-11	CARBON	3.3K 5% 1/4W	R492	1-247-884-11	CARBON	160K 5% 1/4W (WR87ES)
R202	1-247-887-00	CARBON	220K 5% 1/4W	R493	△ 1-212-857-00	FUSIBLE	10 5% 1/4W F
R203	1-249-441-11	CARBON	100K 5% 1/4W	R494	1-249-431-11	CARBON	15K 5% 1/4W (WR775)
R204	1-249-423-11	CARBON	3.3K 5% 1/4W	R494	1-249-432-11	CARBON	18K 5% 1/4W (WR87ES)
R205	1-249-428-11	CARBON	8.2K 5% 1/4W	R495	1-247-854-11	CARBON	9.1K 5% 1/4W (WR87ES)
R206	1-247-864-11	CARBON	24K 5% 1/4W	R495	1-247-862-11	CARBON	20K 5% 1/4W (WR775)
R207	1-249-414-11	CARBON	560 5% 1/4W				
R219	1-249-421-11	CARBON	2.2K 5% 1/4W				
R221	1-249-425-11	CARBON	4.7K 5% 1/4W				
R224	1-249-426-11	CARBON	5.6K 5% 1/4W				
R225	1-249-421-11	CARBON	2.2K 5% 1/4W				
R226	1-249-429-11	CARBON	10K 5% 1/4W				

Note:
The components identified by mark Δ or dotted line with mark Δ are critical for safety. Replace only with part number specified.

Note:
Les composants identifiés par une marque Δ sont critiques pour la sécurité. Ne les remplacer que par une pièce portant le numéro spécifié.

SYSTEM CONTROL

INCLUDING HX PRO(A), HX PRO(B), TRANSLATION(A), TRANSLATION(B), MPX, POWER SW

Ref. No.	Part No.	Description	Remark		
R501	1-249-429-11	CARBON	10K	5%	1/4W
R502	1-249-434-11	CARBON	27K	5%	1/4W
R503	1-249-417-11	CARBON	1K	5%	1/4W
R504	1-249-429-11	CARBON	10K	5%	1/4W
R505	1-249-429-11	CARBON	10K	5%	1/4W
R506	1-249-429-11	CARBON	10K	5%	1/4W
R507	1-249-441-11	CARBON	100K	5%	1/4W
R521	1-247-866-11	CARBON	30K	5%	1/4W (WR87ES)
R521	1-249-440-11	CARBON	82K	5%	1/4W (WR775)
R522	1-247-866-11	CARBON	30K	5%	1/4W (WR87ES)
R522	1-247-870-11	CARBON	43K	5%	1/4W (WR775)
R523	1-247-884-11	CARBON	160K	5%	1/4W (WR775)
R523	1-247-890-11	CARBON	300K	5%	1/4W (WR87ES)
R524	1-247-880-11	CARBON	110K	5%	1/4W (WR775)
R524	1-247-889-00	CARBON	270K	5%	1/4W (WR87ES)
R525	1-249-435-11	CARBON	33K	5%	1/4W
R526	1-247-868-11	CARBON	36K	5%	1/4W (WR775)
R526	1-249-438-11	CARBON	56K	5%	1/4W (WR87ES)
R527	1-247-883-00	CARBON	150K	5%	1/4W (WR87ES)
R527	1-247-891-00	CARBON	330K	5%	1/4W (WR775)
R528	1-247-868-11	CARBON	36K	5%	1/4W (WR775)
R528	1-249-434-11	CARBON	27K	5%	1/4W (WR87ES)
R529	1-247-885-00	CARBON	180K	5%	1/4W (WR775)
R529	1-247-889-00	CARBON	270K	5%	1/4W (WR87ES)
R530	1-247-868-11	CARBON	36K	5%	1/4W (WR87ES)
R530	1-247-892-11	CARBON	360K	5%	1/4W (WR775)
R531	1-247-870-11	CARBON	43K	5%	1/4W (WR775)
R531	1-249-437-11	CARBON	47K	5%	1/4W (WR87ES)
R532	1-247-872-11	CARBON	51K	5%	1/4W (WR775)
R532	1-249-438-11	CARBON	56K	5%	1/4W (WR87ES)
R533	1-247-883-00	CARBON	150K	5%	1/4W (WR775)
R533	1-247-887-00	CARBON	220K	5%	1/4W (WR87ES)
R534	1-249-437-11	CARBON	47K	5%	1/4W (WR87ES)
R534	1-249-438-11	CARBON	56K	5%	1/4W (WR775)
R535	1-247-878-00	CARBON	91K	5%	1/4W (WR775)
R535	1-247-882-11	CARBON	130K	5%	1/4W (WR87ES)
R536	1-247-872-11	CARBON	51K	5%	1/4W (WR87ES)
R536	1-247-878-00	CARBON	91K	5%	1/4W (WR775)
R537	1-247-872-11	CARBON	51K	5%	1/4W (WR775)
R537	1-249-437-11	CARBON	47K	5%	1/4W (WR87ES)

Ref. No.	Part No.	Description	Remark		
R538	1-247-874-11	CARBON	62K	5%	1/4W (WR775)
R538	1-249-437-11	CARBON	47K	5%	1/4W (WR87ES)
R539	1-247-864-11	CARBON	24K	5%	1/4W
R541	1-249-441-11	CARBON	100K	5%	1/4W
R542	1-249-417-11	CARBON	1K	5%	1/4W
R551	1-247-866-11	CARBON	30K	5%	1/4W (WR87ES)
R551	1-249-440-11	CARBON	82K	5%	1/4W (WR775)
R552	1-249-435-11	CARBON	33K	5%	1/4W (WR87ES)
R552	1-249-437-11	CARBON	47K	5%	1/4W (WR775)
R553	1-247-885-00	CARBON	180K	5%	1/4W (WR775)
R553	1-247-890-11	CARBON	300K	5%	1/4W (WR87ES)
R554	1-247-888-11	CARBON	240K	5%	1/4W (WR87ES)
R554	1-249-440-11	CARBON	82K	5%	1/4W (WR775)
R555	1-249-435-11	CARBON	33K	5%	1/4W
R556	1-247-872-11	CARBON	51K	5%	1/4W (WR87ES)
R556	1-249-435-11	CARBON	33K	5%	1/4W (WR775)
R557	1-247-883-00	CARBON	150K	5%	1/4W (WR87ES)
R557	1-247-887-00	CARBON	220K	5%	1/4W (WR775)
R558	1-249-434-11	CARBON	27K	5%	1/4W (WR87ES)
R558	1-249-436-11	CARBON	39K	5%	1/4W (WR775)
R559	1-247-886-11	CARBON	200K	5%	1/4W (WR775)
R559	1-247-890-11	CARBON	300K	5%	1/4W (WR87ES)
R560	1-247-891-00	CARBON	330K	5%	1/4W (WR87ES)
R560	1-247-892-11	CARBON	360K	5%	1/4W (WR775)
R561	1-247-870-11	CARBON	43K	5%	1/4W (WR775)
R561	1-249-437-11	CARBON	47K	5%	1/4W (WR87ES)
R562	1-247-872-11	CARBON	51K	5%	1/4W (WR87ES)
R562	1-249-438-11	CARBON	56K	5%	1/4W (WR775)
R563	1-247-883-00	CARBON	150K	5%	1/4W (WR775)
R563	1-249-441-11	CARBON	100K	5%	1/4W (WR87ES)
R564	1-249-437-11	CARBON	47K	5%	1/4W (WR87ES)
R564	1-249-438-11	CARBON	56K	5%	1/4W (WR775)
R565	1-247-882-11	CARBON	130K	5%	1/4W (WR87ES)
R565	1-249-441-11	CARBON	100K	5%	1/4W (WR775)
R566	1-247-872-11	CARBON	51K	5%	1/4W (WR87ES)
R566	1-249-440-11	CARBON	82K	5%	1/4W (WR775)
R567	1-247-872-11	CARBON	51K	5%	1/4W (WR775)
R567	1-249-437-11	CARBON	47K	5%	1/4W (WR87ES)

SYSTEM CONTROL

INCLUDING HX PRO(A), HX PRO(B), TRANSLATION(A), TRANSLATION(B), MPX, POWER SW

Ref. No.	Part No.	Description	Remark			Ref. No.	Part No.	Description	Remark		
R568	1-247-874-11	CARBON	62K	5%	1/4W (WR775)	R587	1-247-854-11	CARBON	24K	5%	1/4W
R568	1-249-437-11	CARBON	47K	5%	1/4W (WR87ES)	R591	1-249-409-11	CARBON	220	5%	1/4W
R569	1-247-880-11	CARBON	110K	5%	1/4W	R594	1-249-441-11	CARBON	100K	5%	1/4W
R570	1-247-868-11	CARBON	36K	5%	1/4W (WR775)	R595	1-249-442-11	CARBON	510	5%	1/4W
R570	1-249-435-11	CARBON	33K	5%	1/4W (WR87ES)	R598	1-249-441-11	CARBON	100K	5%	1/4W
R571	1-247-874-11	CARBON	62K	5%	1/4W (WR775)	R599	1-249-417-11	CARBON	1K	5%	1/4W
R571	1-249-439-11	CARBON	68K	5%	1/4W (WR87ES)	R602	1-247-887-00	CARBON	220K	5%	1/4W
R572	1-247-864-11	CARBON	24K	5%	1/4W (WR87ES)	R603	1-249-425-11	CARBON	4.7K	5%	1/4W
R572	1-247-866-11	CARBON	30K	5%	1/4W (WR775)	R604	1-249-441-11	CARBON	100K	5%	1/4W
R573	1-247-868-11	CARBON	36K	5%	1/4W	R605	1-249-428-11	CARBON	8.2K	5%	1/4W
R574	1-247-866-11	CARBON	16K	5%	1/4W (WR87ES)	R606	1-249-441-11	CARBON	500K	5%	1/4W
R574	1-249-432-11	CARBON	18K	5%	1/4W (WR775)	R607	1-249-417-11	CARBON	1K	5%	1/4W
R575	1-247-880-11	CARBON	110K	5%	1/4W (WR775)	R608	1-249-441-11	CARBON	100K	5%	1/4W
R575	1-247-881-00	CARBON	120K	5%	1/4W (WR87ES)	R609	1-249-423-11	CARBON	3.3K	5%	1/4W
R576	1-247-868-11	CARBON	36K	5%	1/4W (WR775)	R701	1-249-421-11	CARBON	2.2K	5%	1/4W
R576	1-249-435-11	CARBON	33K	5%	1/4W (WR87ES)	R702	1-249-421-11	CARBON	2.2K	5%	1/4W
R577	1-249-438-11	CARBON	56K	5%	1/4W (WR775)	R703	1-247-856-00	CARBON	11K	5%	1/4W
R577	1-249-439-11	CARBON	68K	5%	1/4W (WR87ES)	R704	1-249-428-11	CARBON	8.2K	5%	1/4W
R578	1-247-874-11	CARBON	62K	5%	1/4W (WR775)	R705	1-249-425-11	CARBON	4.7K	5%	1/4W
R578	1-249-433-11	CARBON	22K	5%	1/4W (WR87ES)	R706	1-249-429-11	CARBON	10K	5%	1/4W
R579	1-247-872-11	CARBON	51K	5%	1/4W (WR87ES)	R707	1-249-409-11	CARBON	220	5%	1/4W
R579	1-249-437-11	CARBON	47K	5%	1/4W (WR775)	R708	1-249-420-11	CARBON	1.8K	5%	1/4W
R580	1-247-866-11	CARBON	30K	5%	1/4W (WR87ES)	R709	1-249-426-11	CARBON	5.6K	5%	1/4W
R580	1-249-436-11	CARBON	39K	5%	1/4W (WR775)	R710	1-249-422-11	CARBON	2.7K	5%	1/4W
R581	1-247-880-11	CARBON	110K	5%	1/4W (WR87ES)	R711	1-249-430-11	CARBON	12K	5%	1/4W
R581	1-247-881-00	CARBON	120K	5%	1/4W (WR775)	R712	1-249-429-11	CARBON	10K	5%	1/4W
R582	1-247-866-11	CARBON	30K	5%	1/4W (WR87ES)	R713	1-249-409-11	CARBON	220	5%	1/4W
R582	1-247-872-11	CARBON	51K	5%	1/4W (WR775)	R714	1-249-429-11	CARBON	10K	5%	1/4W
R583	1-247-870-11	CARBON	43K	5%	1/4W (WR775)	R715	1-249-429-11	CARBON	10K	5%	1/4W
R583	1-249-439-11	CARBON	68K	5%	1/4W (WR87ES)	R721	1-249-437-11	CARBON	47K	5%	1/4W
R584	1-249-431-11	CARBON	15K	5%	1/4W (WR87ES)	R801	1-249-434-11	CARBON	27K	5%	1/4W
R584	1-249-433-11	CARBON	22K	5%	1/4W (WR775)	R802	1-249-434-11	CARBON	27K	5%	1/4W (WR87ES)
R585	1-247-872-11	CARBON	51K	5%	1/4W (WR87ES)	R803	1-249-434-11	CARBON	27K	5%	1/4W (WR87ES)
R585	1-249-438-11	CARBON	56K	5%	1/4W (WR775)	R804	1-249-434-11	CARBON	27K	5%	1/4W
R586	1-247-868-11	CARBON	36K	5%	1/4W (WR775)	R805	1-247-895-00	CARBON	470K	5%	1/4W
R586	1-249-434-11	CARBON	27K	5%	1/4W (WR87ES)	R806	1-247-895-00	CARBON	470K	5%	1/4W
						R807	1-247-895-00	CARBON	470K	5%	1/4W
						R808	1-247-895-00	CARBON	470K	5%	1/4W
						R809	1-249-425-11	CARBON	4.7K	5%	1/4W
						R810	1-247-862-11	CARBON	20K	5%	1/4W
						R811	1-249-425-11	CARBON	4.7K	5%	1/4W
						R812	1-247-862-11	CARBON	20K	5%	1/4W
						R813	1-249-437-11	CARBON	47K	5%	1/4W
						R814	1-247-866-11	CARBON	30K	5%	1/4W
						R815	1-249-434-11	CARBON	27K	5%	1/4W
						R816	1-247-872-11	CARBON	51K	5%	1/4W
						R818	1-247-872-11	CARBON	51K	5%	1/4W
						R819	1-249-405-11	CARBON	100	5%	1/4W
						R820	1-249-437-11	CARBON	47K	5%	1/4W

SYSTEM CONTROL

INCLUDING HX PRO(A), HX PRO(B), TRANSLATION(A), TRANSLATION(B), MPX, POWER SW

Ref. No.	Part No.	Description	Remark
R821	1-247-866-11	CARBON	30K 5% 1/4W
R822	1-249-434-11	CARBON	27K 5% 1/4W
R823	1-247-872-11	CARBON	51K 5% 1/4W
R825	1-249-405-11	CARBON	100 5% 1/4W
R826	1-247-872-11	CARBON	51K 5% 1/4W
R827	1-249-441-11	CARBON	100K 5% 1/4W
R828	1-249-429-11	CARBON	10K 5% 1/4W
R829	1-249-429-11	CARBON	10K 5% 1/4W
R830	1-249-429-11	CARBON	10K 5% 1/4W
R831	1-249-429-11	CARBON	10K 5% 1/4W
R832	1-249-417-11	CARBON	1K 5% 1/4W
R833	1-249-438-11	CARBON	56K 5% 1/4W
R858	1-247-862-11	CARBON	20K 5% 1/4W (WR775)
R858	1-249-432-11	CARBON	18K 5% 1/4W (WR87ES)
R859	1-247-866-11	CARBON	30K 5% 1/4W (WR87ES)
R859	1-249-437-11	CARBON	47K 5% 1/4W (WR775)
R860	1-247-858-11	CARBON	13K 5% 1/4W (WR775)
R860	1-249-429-11	CARBON	10K 5% 1/4W (WR87ES)
R862	1-247-862-11	CARBON	20K 5% 1/4W (WR775)
R862	1-249-428-11	CARBON	8.2K 5% 1/4W (WR87ES)
R863	1-249-437-11	CARBON	47K 5% 1/4W (WR775)
R863	1-249-446-11	CARBON	4.3K 5% 1/4W (WR87ES)
R864	1-247-858-11	CARBON	13K 5% 1/4W (WR775)
R865	1-247-852-11	CARBON	7.5K 5% 1/4W (WR87ES)
R868	1-249-429-11	CARBON	10K 5% 1/4W
R869	1-249-429-11	CARBON	10K 5% 1/4W
R870	1-249-429-11	CARBON	10K 5% 1/4W
R874	1-247-903-00	CARBON	1M 5% 1/4W
R891	1-249-429-11	CARBON	10K 5% 1/4W
R892	1-249-429-11	CARBON	10K 5% 1/4W
R893	1-249-415-11	CARBON	680 5% 1/4W
R894	1-249-415-11	CARBON	680 5% 1/4W
R0391	1-249-428-11	CARBON	8.2K 5% 1/4W (WR87ES)
R0391	1-249-430-11	CARBON	12K 5% 1/4W (WR775)
R0392	1-247-883-00	CARBON	150K 5% 1/4W (WR775)
R0392	1-247-884-11	CARBON	160K 5% 1/4W (WR87ES)
R0393	△ 1-212-857-00	FUSIBLE	10 5% 1/4W F
R0394	1-249-431-11	CARBON	15K 5% 1/4W (WR775)
R0394	1-249-432-11	CARBON	18K 5% 1/4W (WR87ES)
R0395	1-247-854-11	CARBON	9.1K 5% 1/4W (WR87ES)
R0395	1-247-862-11	CARBON	20K 5% 1/4W (WR775)

Ref. No.	Part No.	Description	Remark
R0491	1-249-428-11	CARBON	8.2K 5% 1/4W (WR87ES)
R0491	1-249-430-11	CARBON	12K 5% 1/4W (WR775)
R0492	1-247-883-00	CARBON	150K 5% 1/4W (WR775)
R0492	1-247-884-11	CARBON	160K 5% 1/4W (WR87ES)
R0493	△ 1-212-857-00	FUSIBLE	10 5% 1/4W F
R0494	1-249-431-11	CARBON	15K 5% 1/4W (WR775)
R0494	1-249-432-11	CARBON	18K 5% 1/4W (WR87ES)
R0495	1-247-854-11	CARBON	9.1K 5% 1/4W (WR87ES)
R0495	1-247-862-11	CARBON	20K 5% 1/4W (WR775)

< VARIABLE RESISTOR >

RV121	1-238-600-11	RES. ADJ. CARBON 10K	
RV122	1-238-600-11	RES. ADJ. CARBON 10K	
RV221	1-238-600-11	RES. ADJ. CARBON 10K	
RV222	1-238-600-11	RES. ADJ. CARBON 10K	
RV391	1-238-548-11	RES. ADJ. CARBON 22K	
RV491	1-238-548-11	RES. ADJ. CARBON 22K	
RV501	1-238-953-11	RES. VAR. CARBON 50K/50K (BALANCE) (WR87ES)	
RV502	1-241-133-11	RES. VAR. CARBON 50K/50K (REG LEVEL) (WR87ES)	
RV503	1-238-085-11	RES. VAR. CARBON 20K/20K (PHONE LEVEL) (WR87ES)	
RV0391	1-238-548-11	RES. ADJ. CARBON 22K	
RV0491	1-238-548-11	RES. ADJ. CARBON 22K	

< SWITCH >

S501	1-571-083-11	SWITCH. SLIDE (POWER) (WR87ES)	
S701	△ 1-554-118-00	SWITCH. PUSH (1 KEY) (POWER)	

< TRANSFORMER >

T391	1-433-335-11	TRANSFORMER, BIAS OSCILLATION (WR87ES)	
J391	1-433-367-11	TRANSFORMER, BIAS OSCILLATION (WR775)	
T491	1-433-335-11	TRANSFORMER, BIAS OSCILLATION (WR87ES)	
T491	1-433-367-11	TRANSFORMER, BIAS OSCILLATION (WR775)	
T0391	1-433-335-11	TRANSFORMER, BIAS OSCILLATION (WR87ES)	
T0391	1-433-367-11	TRANSFORMER, BIAS OSCILLATION (WR775)	
T0491	1-433-335-11	TRANSFORMER, BIAS OSCILLATION (WR87ES)	
T0491	1-433-367-11	TRANSFORMER, BIAS OSCILLATION (WR775)	

< TEST PIN >

TP1	* 1-564-505-11	PLUG. CONNECTOR 2P	
TP2	* 1-564-506-11	PLUG. CONNECTOR 3P	
TP691	* 1-564-520-11	PLUG. CONNECTOR 5P	
TP0691	* 1-564-520-11	PLUG. CONNECTOR 5P	

Note:
The components identified by mark **△** or dotted line with mark **△** are critical for safety. Replace only with part number specified.

Note:
Les composants identifiés par une marque **△** sont critiques pour la sécurité. Ne les remplacer que par une pièce portant le numéro spécifié.

SYSTEM CONTROL

INCLUDING HX PRO(A), HX PRO(B), TRANSLATION(A), TRANSLATION(B), MPX, POWER SW

Ref. No. Part No. Description Remark

< CERAMIC >

X801 1-577-358-21 VIBRATOR, CERAMIC (4MHZ)

MISCELLANEOUS

11 Δ 1-551-506-XX CORD, POWER (WR775)
11 Δ 1-555-465-00 CORD, POWER (WR87ES)
76 * 1-575-847-11 WIRE, FLAT TYPE (5 CORE)
77 * 1-575-851-11 WIRE, FLAT TYPE (7 CORE)
78 * 1-575-848-11 WIRE, FLAT TYPE (5 CORE)
79 * 1-575-853-11 WIRE, FLAT TYPE (15 CORE)
80 1-534-517-00 WIRE, FLAT TYPE (11 CORE)
81 * 1-575-780-11 WIRE, FLAT TYPE (7 CORE)
82 * 1-575-850-11 WIRE, FLAT TYPE (9 CORE)
83 * 1-575-781-11 WIRE, FLAT TYPE (9 CORE)

136 * 1-575-847-11 WIRE, FLAT TYPE (5 CORE)
137 * 1-575-851-11 WIRE, FLAT TYPE (7 CORE)
138 * 1-575-848-11 WIRE, FLAT TYPE (5 CORE)
139 * 1-575-853-11 WIRE, FLAT TYPE (15 CORE)
140 1-534-517-00 WIRE, FLAT TYPE (11 CORE)
141 * 1-575-780-11 WIRE, FLAT TYPE (7 CORE)
142 * 1-575-850-11 WIRE, FLAT TYPE (9 CORE)
143 * 1-575-781-11 WIRE, FLAT TYPE (9 CORE)

F701 Δ 1-532-742-11 FUSE, GLASS TUBE (1.6A/125V)
F702 Δ 1-532-742-11 FUSE, GLASS TUBE (1.6A/125V)
HRPE101 A-2003-420-A BASE ASSY, HEAD (REC/PB/ERASE) (WR87ES)
HRPE101 A-2003-477-A BASE ASSY, HEAD (REC/PB/ERASE) (WR775)
M1 X-3359-417-1 MOTOR ASSY (CAPSTAN)
M2 A-2003-474-A MOTOR ASSY (REEL)
S87 1-572-393-11 SWITCH, LEAF (DIRECTION)
T701 Δ 1-450-431-11 TRANSFORMER, POWER

ACCESSORY & PACKING MATERIAL

1-559-533-11 CORD, CONNECTION
* 3-354-918-61 INDIVIDUAL CARTON
* 3-354-918-71 INDIVIDUAL CARTON (WR87ES)
* 3-359-942-01 CUSHION
3-703-453-01 INSTRUCTION (WR87ES/WR775:US)
* 3-704-343-01 SHEET (STANDARD), PROTECTION
3-753-337-21 MANUAL, INSTRUCTION (ENGLISH) (WR87ES)
3-753-338-21 MANUAL, INSTRUCTION (ENGLISH)
3-753-388-31 MANUAL, INSTRUCTION
(WR775:Canadian, FRENCH)

Ref. No. Part No. Description Remark

HARDWARE LIST

1 7-682-548-09 SCREW +BVTT 3X8 (S)
2 7-621-849-00 SCREW (BV/RING)
3 7-685-646-79 SCREW +BVTP 3X8 TYPE2 SLIT
4 7-682-547-04 SCREW +BVTT 3X6 (S)
5 7-682-547-09 SCREW +BVTT 3X6 (S)
6 7-621-775-10 SCREW +B 2.6X4 (WR87ES)

7 7-621-773-95 SCREW +BVTT 2.6X6 (S)
8 7-685-534-19 SCREW +BTP 2.5X8 TYPE2 N-S (WR87ES)
9 7-621-770-67 SCREW +BVTT 2.6X6 (S) (WR87ES)
#10 7-627-556-08 SCREW +P 2.6X2.8
#11 7-621-775-00 SCREW +B 2.6X3
#12 7-621-773-93 SCREW (PANEL 2.6 TP2) (WR775)

Note:
The components identified by mark Δ or dotted line with mark Δ are critical for safety. Replace only with part number specified.

Note:
Les composants identifiés par une marque Δ sont critiques pour la sécurité. Ne les remplacer que par une pièce portant le numéro spécifié.

TC-WR87ES/WR775

SONY® SERVICE MANUAL

US Model
Canadian Model

TC-WR775

US Model

TC-WR87ES

CORRECTION-1

File this correction with the service manual.

 :Correct Portion

1. SECTION 4 ELECTRICAL ADJUSTMENTS (Service Manual Page 9.)

Playback Level Adjustment DECK A DECK B

Procedure :

—Forward Playback Mode—

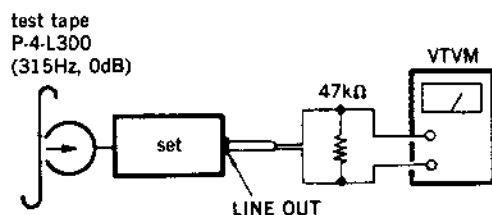

Adjust each RV11 (L-CH) and RV21 (R-CH) so that the VTVM reading becomes within adjustment limits below on both of deck A and deck B.

Adjustment Limits :

LINE OUT level : $-5 \pm 0.5\text{dB}$ (0.412 to 0.461V)

Level difference between channels : within 0.5dB



Confirm the LINE OUT level does not change in playback mode while changing the mode from playback to stop several times.

Adjustment Location : MD(C) board (deck A, deck B)
(See page 10)

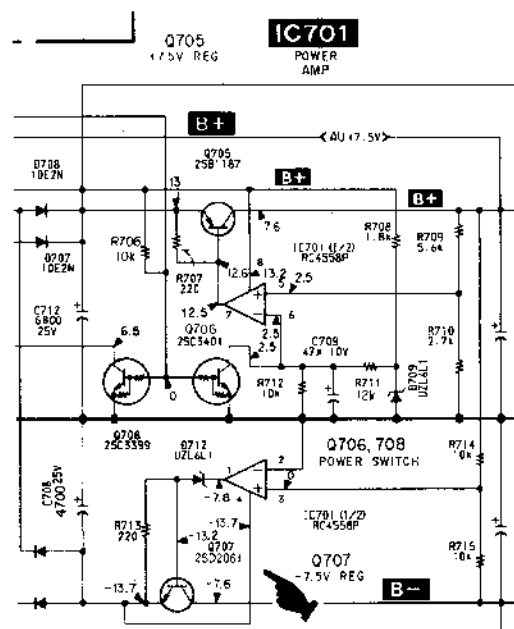
2. SECTION 5 DIAGRAMS Service Manual Page 20. (Location G~J-8~10)



3. SECTION 7 ELECTRICAL PARTS LIST (Service Manual Page 40.)

Ref. No.	Part No.	Description	Remark
Q701	8-729-906-97	TRANSISTOR 2SD2061-F	
Q702	8-729-920-05	TRANSISTOR 2SC2603-EF	
Q703	8-729-821-04	TRANSISTOR 2SA1317-STJ	
Q704	8-729-924-90	TRANSISTOR 2SB1370-EF	
Q705	8-729-924-90	TRANSISTOR 2SB1370-EF	
Q706	8-729-900-85	TRANSISTOR DTC144WS	
Q707	8-729-906-97	TRANSISTOR 2SD2061-F	

Sony Corporation
Audio Group

9-956-430-91

English
91F1834-1
Printed in Japan
©1991.6

Published by Customer Relations and Service Group