

# TC-WA7ESA/WE505/WE605S/ WE705S/WR550Z

## SERVICE MANUAL

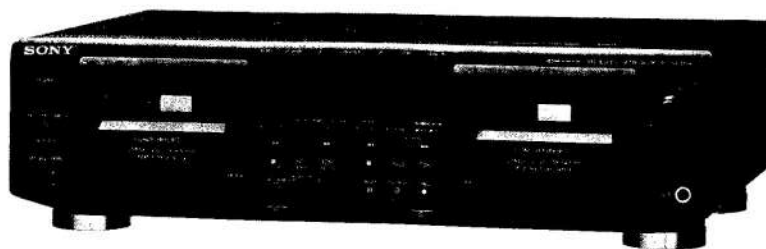

Photo : TC-WE705S

*US Model*  
TC-WA7ESA/WE605S/WR550Z

*Canadian Model*  
TC-WA7ESA/WE605S

*AEP Model*  
TC-WE505/WE705S

*UK Model*  
TC-WE505

*E Model*  
*Australian Model*  
*Chinese Model*  
TC-WE605S

\* Dolby noise reduction and HX Pro headroom extension manufactured under license from Dolby Laboratories Licensing Corporation. HX Pro originated by Bang & Olufsen.

"DOLBY", the double-D symbol  and "HX PRO" are trademarks of Dolby Laboratories Licensing Corporation.

Model Name Using Similar Mechanism		TC-WA7ES/WR565/WE665S
Tape Transport Mechanism Type	DECK-A	TC-WE605S/WR550Z : TCM-190RA12CL TC-WE505 : TCM-190RA14CL TC-WA7ESA : TCM-190RA17CL TC-WE705S : TCM-190RA18C
	DECK-B	TC-WA7ESA/WE705S : TCM-190RB11C TC-WE505/WE605S/WR550Z : TCM-190RB12CL

### SPECIFICATIONS

#### System

Recording system  
4-track 2-channel stereo

Fast-winding time (approx.)  
90 sec. (with Sony C-60 cassette)

High-speed fast-winding time (approx.) (TC-WA7ESA and TC-WE705S only)  
45 sec. (with Sony C-60 cassette)

Bias  
AC bias

Signal-to-noise ratio (at peak level and weighted with Dolby NR off)  
Type I tape, Sony Type I (NORMAL): 55 dB  
Type II tape, Sony Type II (HIGH): 57 dB  
Type IV tape, Sony Type IV (METAL): 58 dB

S/N ratio improvement (approximate values)  
With Dolby B NR on: 5 dB at 1 kHz, 10 dB at 5 kHz  
With Dolby C NR on: 15 dB at 500 Hz, 20 dB at 1 kHz  
With Dolby S NR on (unavailable on the TC-WE505):  
10 dB at 100 Hz, 24 dB at 1 kHz

#### Harmonic distortion

0.4% (with Type I tape, Sony Type I (NORMAL):  
160 nWb/m 315 Hz, 3rd H.D.)  
1.8% (with Type IV tape, Sony Type IV (METAL):  
250 nWb/m 315 Hz, 3rd H.D.)

#### Frequency response (Dolby NR off)

##### Tape type

Type I tape, Sony Type I (NORMAL)	30 - 16,000 Hz ( $\pm 3$ dB, IEC), 20 - 17,000 Hz ( $\pm 6$ dB)
Type II tape, Sony Type II (HIGH)	30 - 17,000 Hz ( $\pm 3$ dB, IEC), 20 - 18,000 Hz ( $\pm 6$ dB)
Type IV tape, Sony Type IV (METAL)	30 - 19,000 Hz ( $\pm 3$ dB, IEC), 20 - 20,000 Hz ( $\pm 6$ dB), 30 - 13,000 Hz ( $\pm 3$ dB, -4 dB recording)

- Continued on page 2 -



STEREO CASSETTE DECK  
**SONY**®

Wow and flutter

TC-WA7ESA/WE705S/WE605S/ WR550Z	TC-WE505
±0.13% W. Peak (IEC)	±0.14% W. Peak (IEC)
0.07% W. RMS (NAB)	0.08% W. RMS (NAB)
±0.18% W. Peak (DIN)	±0.19% W. Peak (DIN)

Variable pitch range (approx.) (TC-WE705S and TC-WE505 only)  
-30 to +30%

Inputs

Line inputs (phono jacks)  
Sensitivity : 0.16 V  
Input impedance : 47 kilohms

Outputs

Line outputs (phono jacks)  
Rated output level : 0.5 V at a load impedance of  
47 kilohms  
Load impedance : Over 10 kilohms

Headphones (stereo phone jack)  
Output level : 0.25 mW at a load impedance of  
32 ohms

General

Power requirements

Where purchased	Power requirements
US, Canadian, Panama model	120V AC, 60Hz
AEP, UK, German, Malaysia, Singapore, Chinese model	220 - 230V AC, 50/60Hz
Australian model	240V AC, 50/60Hz
E model	120/220/240V AC, 50/60Hz

Power consumption  
26W

Dimensions (approx.) (w/h/d)  
UK, and Australian model :  
430 x 120 x 303 mm (w/h/d)  
(17 x 4 3/4 x 12 inches)  
EXCEPT UK, Australian model :  
430 x 120 x 290 mm (w/h/d)  
(17 x 4 3/4 x 11 1/2 inches)  
including projecting parts and controls

Mass (approx.)  
4.2 kg (9 lbs 5 oz)

Supplied accessories

Audio connecting cords (2 phono plugs - 2 phono  
plugs) (2)  
Remote commander (RM-J910) (1) :  
(WA7ESA : Canadian model)

Design and specifications are subject to change without  
notice.

TABLE OF CONTENTS

Section	Title	Page
	Specifications .....	1
	Safety Check-out .....	3
<b>1. GENERAL</b>		
1-1.	Identifying the Parts .....	4
<b>2. DISASSEMBLY</b>		
2-1.	Front Panel Removal .....	5
2-2.	Mechanism Deck .....	5
2-3.	Capstan Motor, Reel Motor .....	6
2-4.	Head, Pinch Roller .....	6
<b>3. ADJUSTMENTS</b>		
3-1.	Mechanical Adjustments .....	7
3-2.	Electrical Adjustments .....	7
<b>4. EXPLANATION OF IC TERMINALS</b>		11
<b>5. DIAGRAMS</b>		
5-1.	Block Diagram .....	13
5-2.	Printed Wiring Boards (Main Section) .....	18
5-3.	Schematic Diagram (Main Section) .....	23
5-4.	Schematic Diagram (Panel Section) .....	28
5-5.	Schematic Diagram (Audio Section) .....	30
5-6.	Printed Wiring Boards (Audio Section) .....	33
5-7.	Printed Wiring Boards (Dolby Section) .....	36
5-8.	Schematic Diagram (Dolby Section) .....	37
<b>6. EXPLODED VIEWS</b>		
6-1.	Chassis Section .....	39
6-2.	Front Panel Section .....	41
6-3.	Mechanism Section 1 .....	42
6-4.	Mechanism Section 2 .....	43
<b>7. ELECTRICAL PARTS LIST</b>		44

MODEL IDENTIFICATION  
(Specification Label)

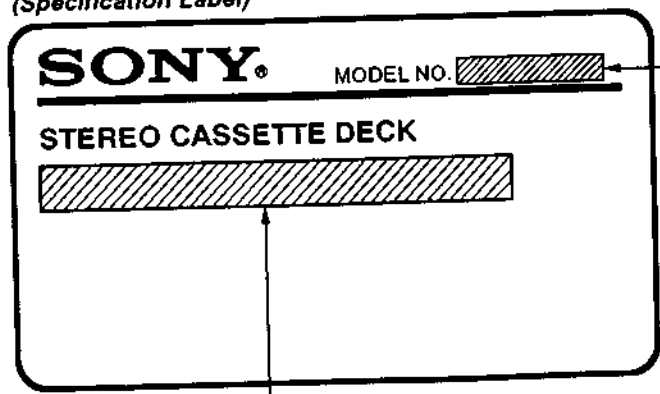

TC-WA7ESA  
TC-WE505  
TC-WE605S  
TC-WE705S  
TC-WR550Z

US, Canadian, Panama model : AC 120V 60Hz  
Australian model : AC 240V~50/60Hz  
AEP, UK, Malaysia, Singapore,  
Chinese, German model : AC 220-230V-50/60Hz  
E model : AC 120/220/240V~50/60Hz

## SAFETY CHECK-OUT

After correcting the original service problem, perform the following safety check before releasing the set to the customer:

Check the antenna terminals, metal trim, "metallized" knobs, screws, and all other exposed metal parts for AC leakage. Check leakage as described below.

### LEAKAGE TEST

The AC leakage from any exposed metal part to earth ground and from all exposed metal parts to any exposed metal part having a return to chassis, must not exceed 0.5 mA (500 microamperes). Leakage current can be measured by any one of three methods.

1. A commercial leakage tester, such as the Simpson 229 or RCA WT-540A. Follow the manufacturers' instructions to use these instruments.
2. A battery-operated AC milliammeter. The Data Precision 245 digital multimeter is suitable for this job.

3. Measuring the voltage drop across a resistor by means of a VOM or battery-operated AC voltmeter. The "limit" indication is 0.75 V, so analog meters must have an accurate low-voltage scale. The Simpson 250 and Sanwa SH-63Trd are examples of a passive VOM that is suitable. Nearly all battery operated digital multimeters that have a 2V AC range are suitable. (See Fig. A)

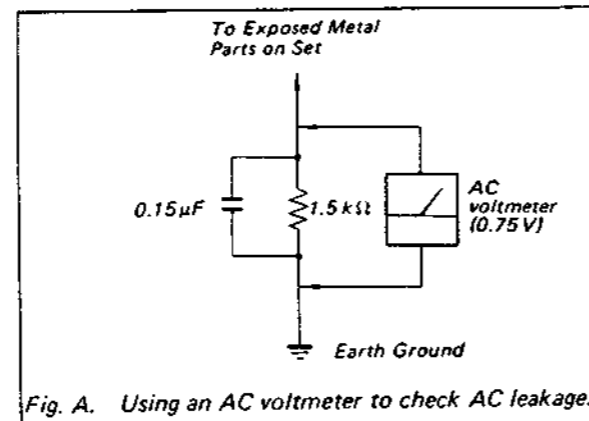

**SAFETY-RELATED COMPONENT WARNING!!**  
COMPONENTS IDENTIFIED BY MARK  $\Delta$  OR DOTTED LINE WITH MARK  $\Delta$  ON THE SCHEMATIC DIAGRAMS AND IN THE PARTS LIST ARE CRITICAL TO SAFE OPERATION. REPLACE THESE COMPONENTS WITH SONY PARTS WHOSE PART NUMBERS APPEAR AS SHOWN IN THIS MANUAL OR IN SUPPLEMENTS PUBLISHED BY SONY.

**ATTENTION AU COMPOSANT AYANT RAPPORT À LA SÉCURITÉ!**  
LES COMPOSANTS IDENTIFIÉS PAR UNE MARQUE  $\Delta$  SUR LES DIAGRAMMES SCHÉMATIQUES ET LA LISTE DES PIÈCES SONT CRITIQUES POUR LA SÉCURITÉ DE FONCTIONNEMENT. NE REMPLACER CES COMPOSANTS QUE PAR DES PIÈCES SONY DONT LES NUMÉROS SONT DONNÉS DANS CE MANUEL OU DANS LES SUPPLÉMENTS PUBLIÉS PAR SONY.

## SECTION 1 GENERAL

### 1-1. IDENTIFYING THE PARTS

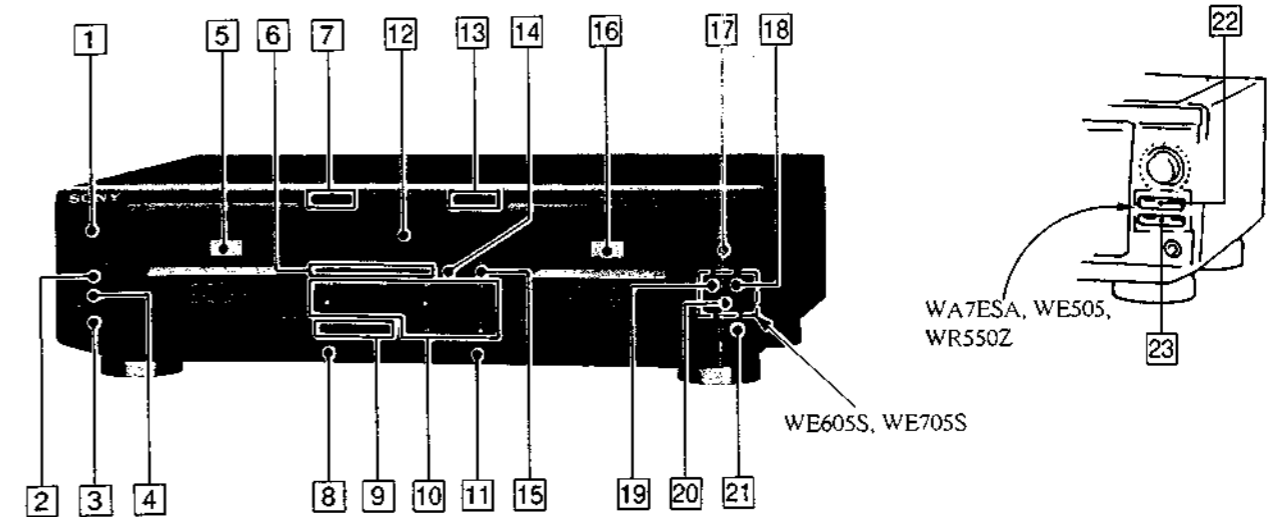

#### FRONT PANEL

- |   |   |
|---|---|
| <p>1 POWER switch</p> <p>2 DIRECTION MODE switch</p> <p>3 PITCH control</p> <p>4 PITCH control ON/OFF switch</p> <p>5 Deck-A</p> <p>6 RMS<sup>™</sup> operation buttons<br/>RMS/START buttons<br/>SET buttons<br/>CHECK buttons<br/>DISPLAY buttons</p> <p>7 COUNTER buttons (deck-A)<br/>RESET button<br/>MEMORY button</p> <p>8 <math>\Delta</math> (eject) button (deck-A)</p> <p>9 DOLBY NR switches<br/>OFF/ON/FILTER ON switch<br/>B/C/S switch</p> <p>10 Tape operation buttons<br/>◀ (leftward fastwinding)/AMS<sup>™</sup>/RMS<sup>™</sup> - button<br/>▶ (rightward fastwinding)/AMS<sup>™</sup>/RMS<sup>™</sup> + button<br/>■ (stop)/(RMS<sup>™</sup>) CLEAR button<br/>◀ (reverse play)/(RMS<sup>™</sup>) BACK button<br/>▶ (forward play)/(RMS<sup>™</sup>) FRONT button<br/>   PAUSE button<br/>○ REC MUTE (record muting) button<br/>● REC (record muting) button</p> | <p>11 <math>\Delta</math> (eject) button (deck-B)</p> <p>12 Display panel</p> <p>13 COUNTER buttons (deck-B)<br/>RESET button<br/>MEMORY button</p> <p>14 AUTO CAL button</p> <p>15 SYNCHRO DUBBING buttons<br/>HIGH button<br/>NORMAL button</p> <p>16 Deck-B</p> <p>17 AUTO REC (recording) LEVEL control</p> <p>18 ARL button</p> <p>19 FADER button } (WE605S, WE705S)</p> <p>20 SYNCHRO button</p> <p>21 PHONES jack (stereo phone jack)</p> <p>22 ARL button } (WA7ESA, WE505, WR550Z)</p> <p>23 FADER button</p> <p><sup>™</sup> Random Music Sensor<br/><sup>™</sup> Automatic Music Sensor</p> |
|---|---|

## SECTION 2 DISASSEMBLY

Note : Follow the disassembly procedure in the numerical order given.

**CASE**  
Unscrew the four case attachment screws M3 × 8 and remove the case.

### 2-1. FRONT PANEL REMOVAL

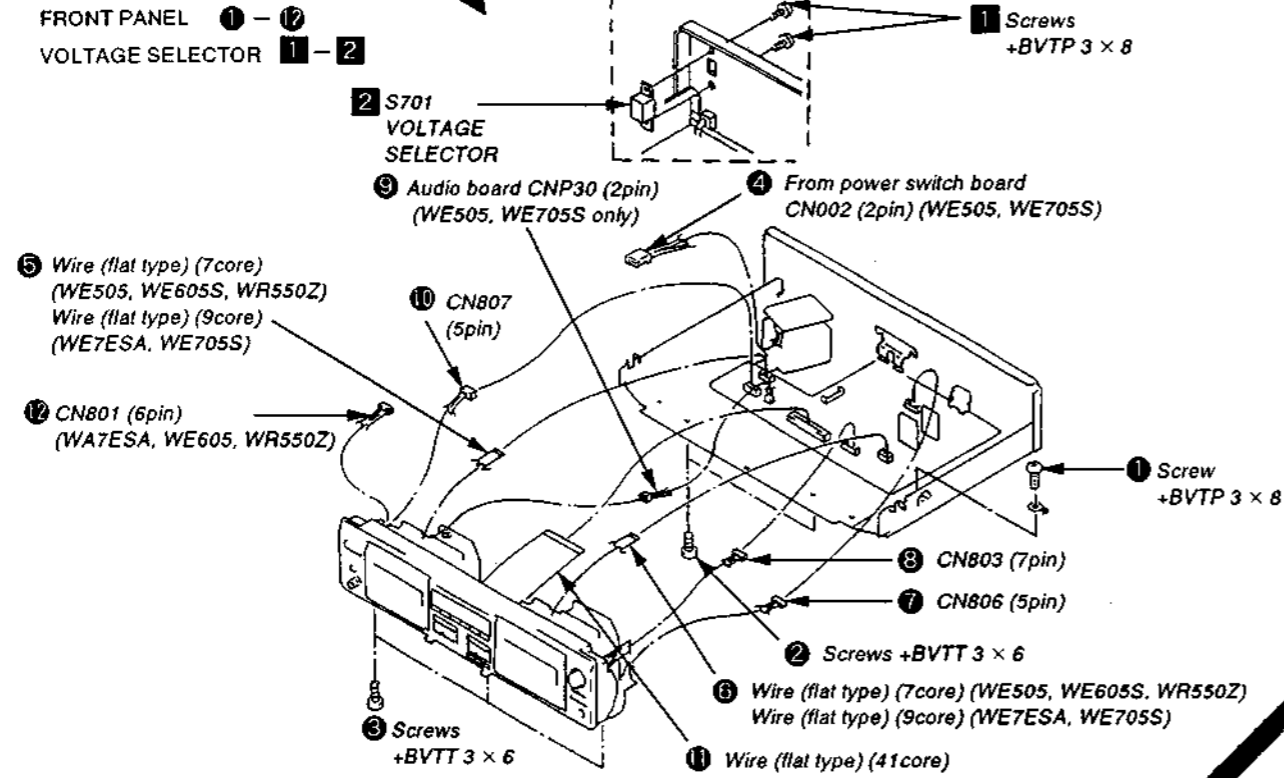

### 2-2. MECHANISM DECK

① Press the EJECT button.

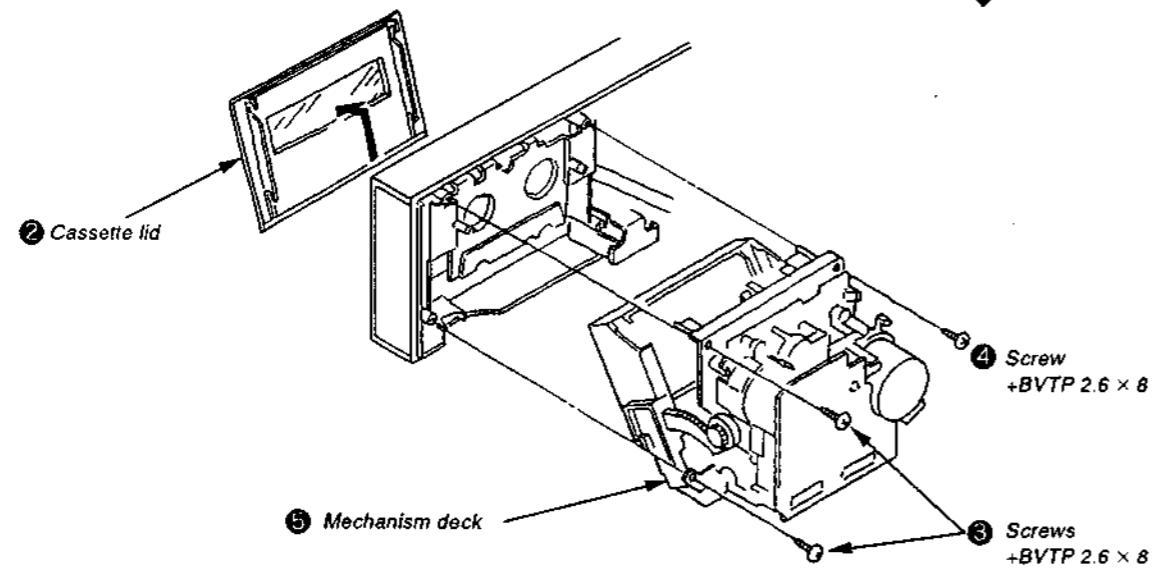

### 2-3. CAPSTAN MOTOR, REEL MOTOR

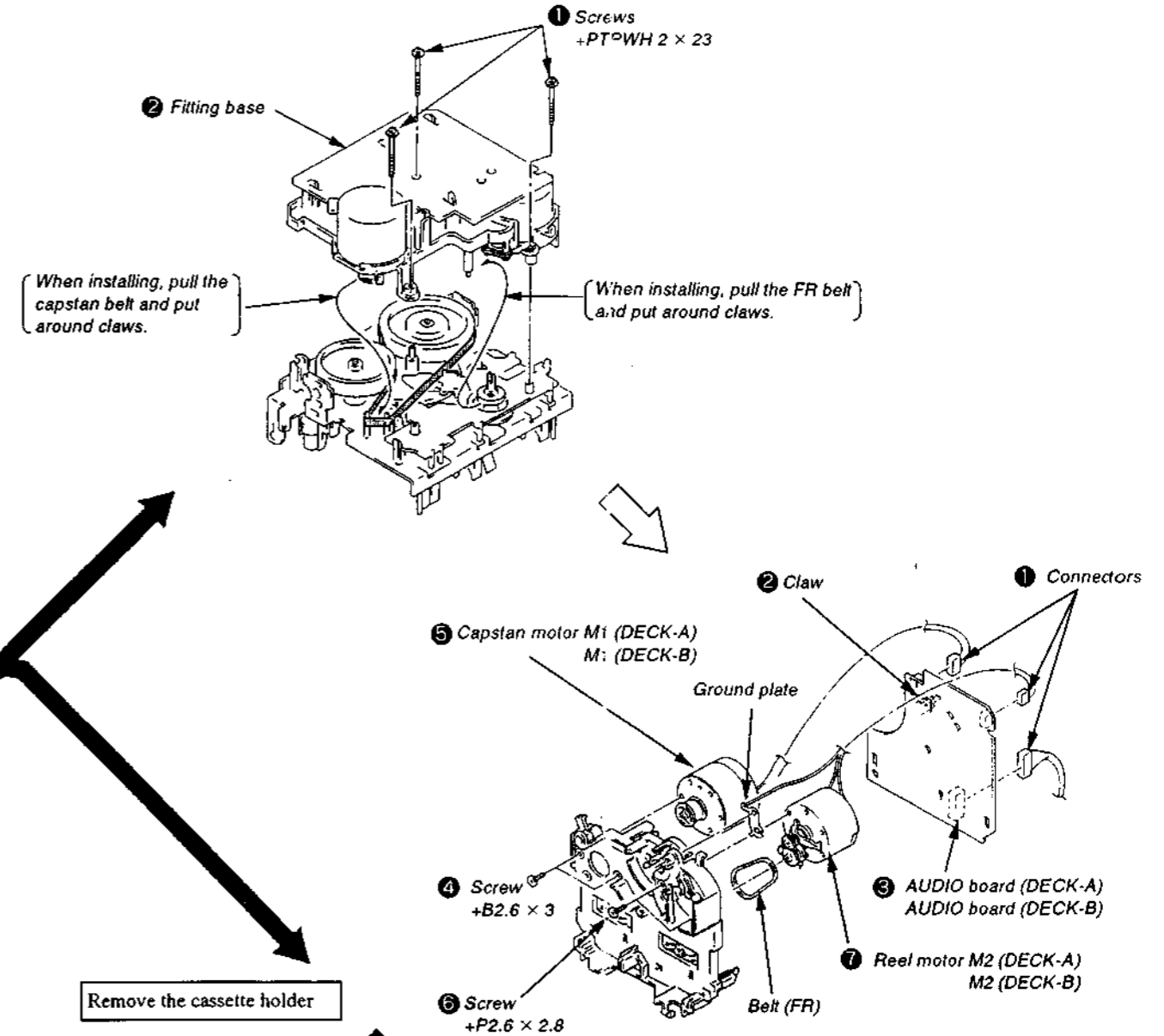

Remove the cassette holder

### 2-4. HEAD, PINCH ROLLER

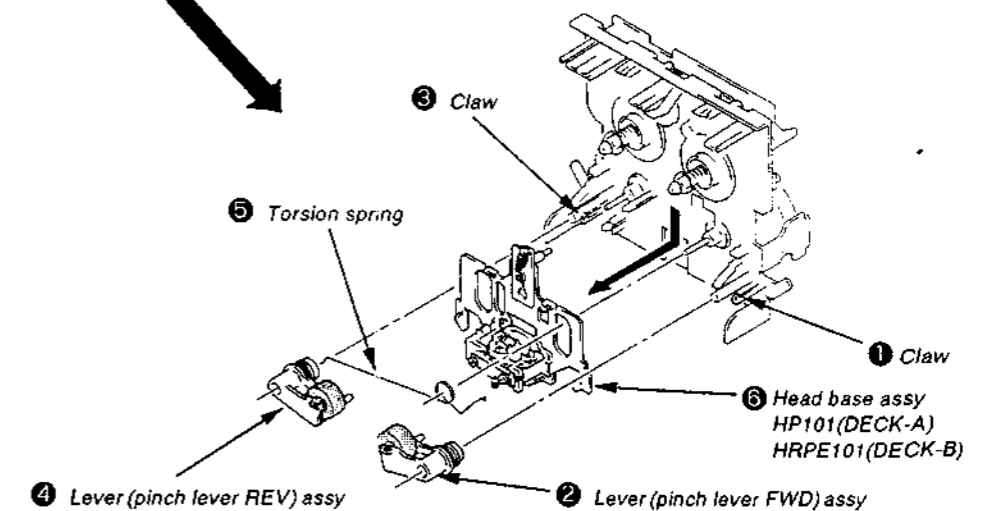

## SECTION 3 ADJUSTMENTS

### 3-1. MECHANICAL ADJUSTMENTS

#### PRECAUTION

1. Clean the following parts with a denatured alcohol-moistened swab:
 

record/playback/erase head	pinch roller
rubber belts	capstan
idlers	
2. Demagnetize the record/playback head with a head demagnetizer.
3. Do not use a magnetized screwdriver for the adjustment.
4. After the adjustments, apply suitable locking compound to the parts adjusted.
5. The adjustments should be performed with the rated power supply voltage unless otherwise noted.

#### Torque Measurement

Torque	Torque meter	Meter reading
Forward	CQ-102C	30 to 65g · cm (0.42 to 0.9 oz · inch)
Forward back tension	CQ-102C	DECK-A : 1 to 6g · cm (0.014 to 0.083 oz · inch) DECK-B : 2 to 9g · cm (0.03 to 0.12 oz · inch)
Reverse	CQ-102RC	30 to 65g · cm (0.42 to 0.9 oz · inch)
Reverse back tension	CQ-102RC	1 to 6g · cm (0.014 to 0.083 oz · inch)
FF/REW	CQ-201B	70 to 120g · cm (0.98 to 1.66 oz · inch)

### 3-2. ELECTRICAL ADJUSTMENTS

#### PRECAUTION

1. The adjustment should be performed in the publication.  
(Be sure to make playback adjustment at first.)
2. The adjustments and measurement should be performed for both L-CH and R-CH.
  - Switch position  
DOLBY NR switch : OFF  
DIRECTION MODE switch :  $\Rightarrow$
  - Standard record position :  
Deliver the standard input signal level to input jack and set the REC LEVEL control to obtain the standard output signal level as follows.

— Record Mode —

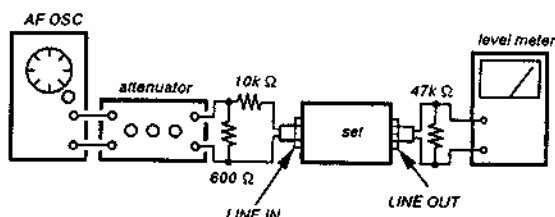

#### Standard Input Level

Input terminal	LINE IN
source impedance	10k $\Omega$
input signal level	0.5V ( - 3.8dB)

#### Standard Output Level

Output terminal	LINE OUT
load impedance	47k $\Omega$
output signal level	0.5V ( - 3.8dB)

#### Test Tape

Tape	Contents	Use
P-4-A100	10kHz, - 10dB	Azimuth Adjustment
P-4-L300	315Hz, 0dB	PB Level Adjustment
WS-48B	3kHz, 0dB	Tape Speed Adjustment

$$0\text{dB} = 0.775\text{V}$$

#### Test Mode

1. Insert a short-circuit plug into TP801 (2P) and turn ON the power switch.  
At first, all the fluorescent tubes light up, then the system returns to normal display. (However, "0.00" is not displayed on the counter.)
2. To release the test mode, remove the short plug and turn off the power switch.
3. Remove the short plug after completion of adjustment.

#### Record/Playback Head Azimuth Adjustment

**DECK-A**   **DECK-B**

#### Procedure :

1. Forward playback Mode

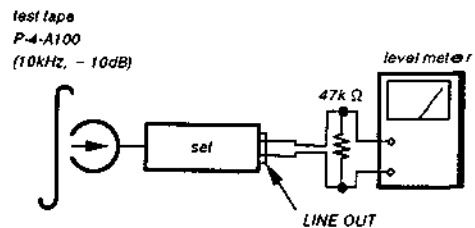

2. Turn the adjustment screw for the maximum output levels. If these levels do not match, turn the adjustment screw until both of output levels match together within 1dB.

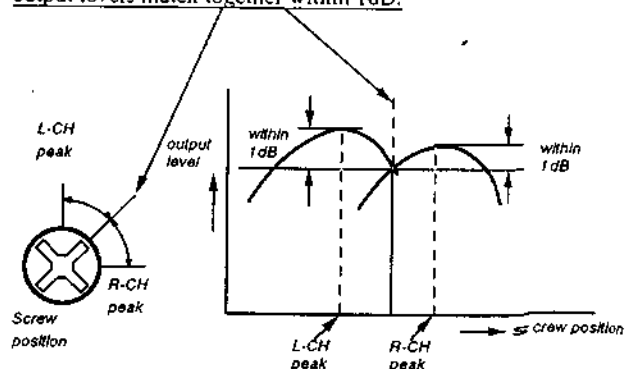

### 3. Playback Mode

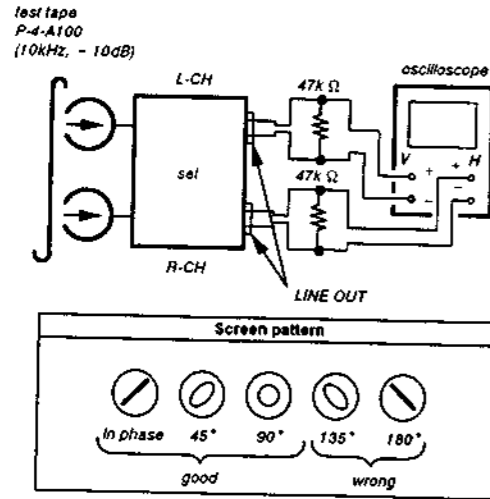

4. Change the reverse playback mode and repeat the steps 1 to 3.
5. After the adjustment, lock the adjustment screws with suitable locking compound.

Adjustment Location : - record/playback head -

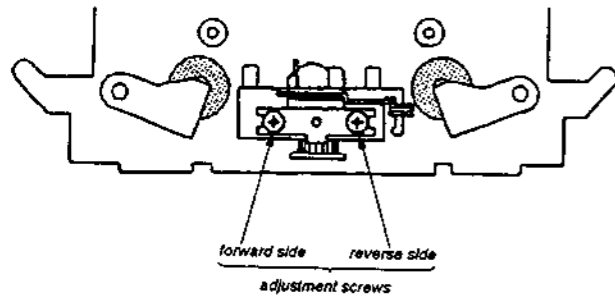

### Tape Speed Adjustment DECK-A DECK-B

Procedure :

- Forward Playback Mode -

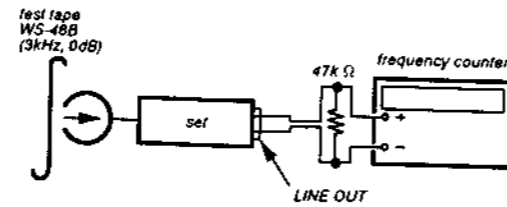

(High speed adjustment)

1. Set to test mode. (Refer to page 7)
2. Set to FWD playback mode.
3. Keep on pressing the HIGH SPEED DUBBING switch.
4. Adjust RV72 so that the frequency counter reading becomes  $6,000 \pm 20\text{Hz}$ .
5. Release test mode after adjustment is completed.

(Normal speed adjustment)

1. Set to FWD playback mode.
2. Adjust RV71 so that the frequency counter reading becomes  $3,000 \pm 10\text{Hz}$ .

(Pitch control adjustment) (TC-WE505/WE705S only)

1. Turn ON the PITCH CONTROL switch.
2. Set RV902 to mechanical center.
3. Set to FWD playback mode.
4. Adjust RV601 so that the frequency counter reading becomes  $3,000 \pm 10\text{Hz}$ .

Frequency difference between the beginning and the end of the tape should be within 3%.

Frequency difference between the deck A and deck B the beginning of the tape should be within 1.5%.

Adjustment Location : AUDIO board, MAIN board.  
(See page 10)

### Playback Level Adjustment DECK-A DECK-B

Procedure :

- Forward Playback Mode -

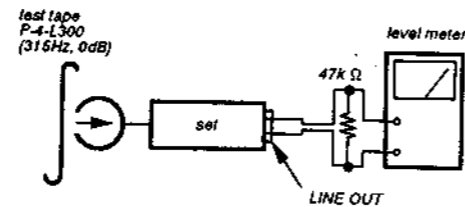

Adjust RV11(L-CH) and RV21(R-CH) so the level meter reading becomes the adjustment limits below.

Adjustment Value :

LINE OUT level :  $-7.7 \pm 0.5\text{dB}$  (0.301 to 0.338V)

Level difference between channels : within 0.5dB

Confirm the LINE OUT level does not change in playback mode while changing the mode from playback to stop several times.

Adjustment Location : AUDIO board. (See page 10)

### Bias Consumption Current Adjustment DECK-B

This adjustment should be performed when replacing the head assy or the bias oscillating transformer (T81, T91).

Procedure :

< > : R-CH

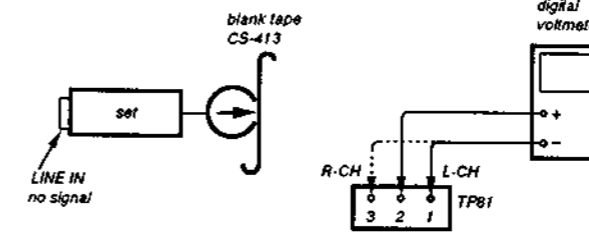

1. Connect the digital voltmeter to test point TP81.
2. Set RV81(RV91) to mechanical center.
3. Set to FWD record mode.
4. Adjust T81(T91) so that the digital voltmeter reading becomes minimum.

Adjustment Value : Maximum 220mV

Adjustment Location : AUDIO board. (See page 10)

### Record Bias Adjustment DECK-B

Setting :

REC LEVEL control : standard record position (Refer to page 7.)

Procedure :

1. Record Mode

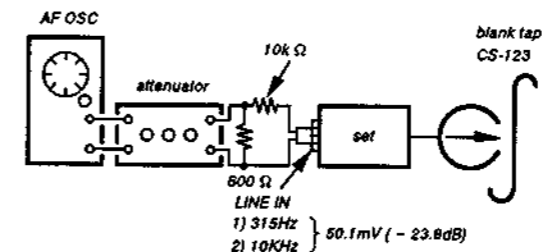

2. Playback Mode

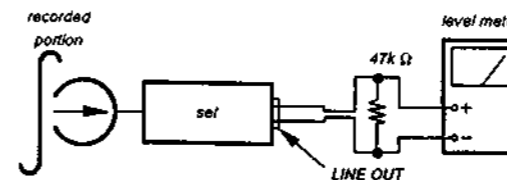

Confirm that the 10kHz playback output is  $0 \pm 0.5\text{dB}$  relative to the 315Hz output. If necessary, adjust RV81 (L-CH), RV91(R-CH) and repeat the steps given above.

Adjustment Location : AUDIO board. (See page 10)

### Record Level Adjustment DECK-B

Setting :

REC LEVEL control : standard record position (Refer to page 7.)

Procedure :

1. Record Mode

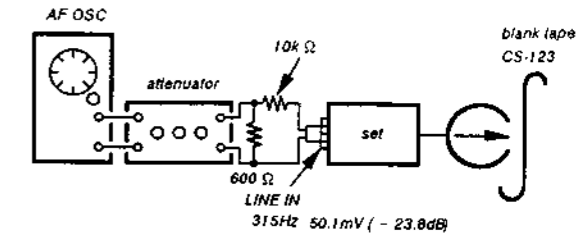

2. Playback Mode

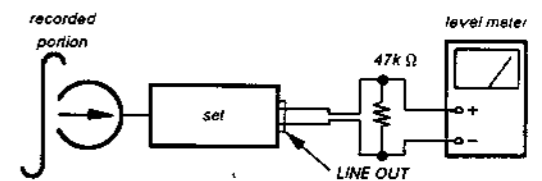

Confirm playback the tape recorded become adjustment level as follows.

If necessary, adjust RV101(L-CH), RV201(R-CH) and repeat the steps 1 and 2.

Adjustment Value :

LINE OUT level :  $-23.8 \pm 0.5\text{dB}$  (47.2 to 53mV)

Adjustment Location : MAIN board.  
(See page 10)

[MAIN BOARD]

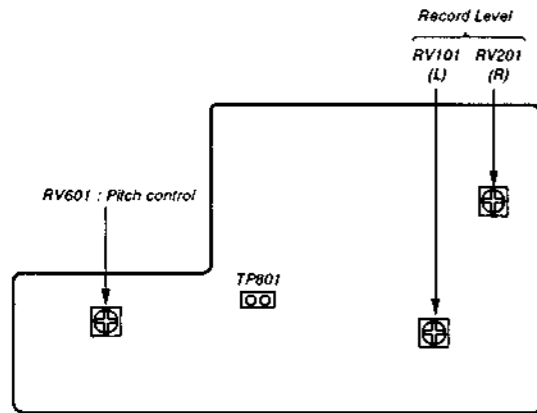

DECK-A :  
[AUDIO BOARD]

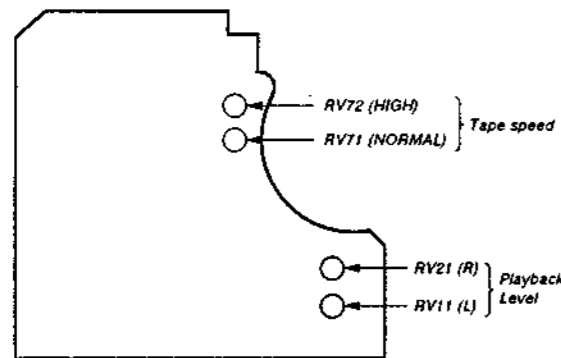

DECK-B :  
[AUDIO BOARD]

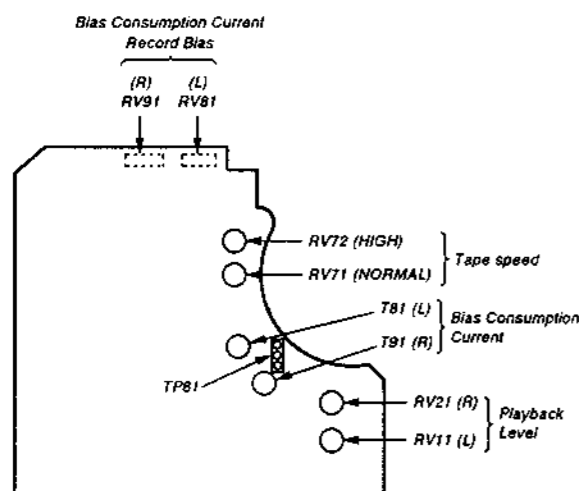

SECTION 4  
EXPLANATION OF IC TERMINALS

IC801 CXP8224-043Q (SYSTEM CONTROL/VFD DRIVE)

Pin No.	Pin name	I/O	Description
1	A STOP SW	I	Mechanism stop switch for deck-A. H : Stop
2	VERSION	I	Version select terminal.
3	TEST	I	Test mode select terminal. L : Test
4	SIRCS	I	Sircs signal input terminal.
5	AMS IN	I	AMS signal input terminal. L : Music present.
6	VOL OUT	O	REC level control output (PWM).
7	SEL A/B	O	Playback A/B selector. L : A, H : B
8	CONTROL A IN	I	Control A input.
9	CONTROL A OUT	O	Control A output.
10	GP CAL 0	O	GEQ CAL-0 output for auto calibration.
11	GP CAL 1	O	GEQ CAL-1 output for auto calibration.
12	REC CAL 0	O	Recording CAL-0 output for auto calibration.
13	REC COL 1	O	Recording CAL-1 output for auto calibration.
14	POWER IN	I	Power OFF Detection terminal.
15	REC EQ H/L	O	REC EQ high/normal select. L : Normal.
16	CAL/OFF, B, C/S	O	Audio Selector. H : CAL/Open : NR-OFF, B, C/L : NR-S.
17	DOLBY C/B/OFF	O	Dolby NR Selector. H : C/Open : B/L : OFF.
18	REC MUTE	O	Recording mute output. L : Mute ON, H : Mute OFF.
19	POWER OUT	O	Power hold output.
20	REC/PB	O	Dolby NR mode selector. L : Playback, H : Record.
21	PASS/MUTE/DOLBY	O	Audio selector. L : Dolby/Open : Mute/H : Pass.
22	BS/AMS/OFF	O	AMS amp selector. L : OFF/Open : AMS/H : OFF.
23	BIAS	O	Bias ON/OFF output. L : OFF, H : ON.
24	RELAY	O	Relay record/playback selector. L : Record.
25	B STOP SW	I	Mechanism stop switch for deck-B.
26	B METAL	I	Deck-B metal tape detection.
27	B 70/120	I	70/120 $\mu$ tape selector (deck-B). L : with claw.
28	B S-REEL IN	I	Supply reel rotation detection at deck-B.
29	B S-REEL OUT	O	Supply reel rotation detection at deck-B.
30	B T-REEL IN	I	Take-up reel rotation detection at deck-B.
31	B T-REEL OUT	O	Take-up reel rotation detection at deck-B.
32	B-HALF	I	Half pawl input at deck-B. (A/B converter)
33	KEY 1	I	KEY 1 input (A/D converter).
34	KEY 2	I	KEY 2 input (A/D converter).
35	KEY 3	I	KEY 3 input (A/D converter).
36	KEY 4	I	KEY 4 input (A/D converter).
37	VOL IN	I	Record volume input. (A/D converter)
38	RESET	I	System reset input terminal.
39	EXTAL	I	System clock oscillator input. (10.0MHz)
40	EXTAL	O	System clock oscillator output. (10.0MHz)

Pin No.	Pin name	I/O	Description
41	Vss	-	Ground.
42	TX	-	Not used. (Ground connection)
43	TEX	-	Not used. (Ground connection)
44	METER L	I	Meter L-CH input. (A/D converter)
45	METER R	I	Meter R-CH input. (A/D converter)
46	AVREF	I	Reference voltage input for A/D converter.
47	AVss	-	Ground for A/D converter.
48	LED (ARL)	O	ARL LED ON/OFF driver. H : ON.
49	LED (SYNC)	O	CD synchro LED ON/OFF drive. H : ON.
50	OSC H/L	O	OSC frequency H/L selection for auto calibration.
51	OSC ON/OFF	O	OSC ON/OFF output for auto calibration.
52	BIAS CAL 0	O	EQ bias CAL-0 output for auto calibration.
53	BIAS CAL 1	O	EQ bias CAL-1 output for auto calibration.
54	BIAS CAL 2	O	EQ bias CAL-2 output for auto calibration.
55	BIAS CAL 3	O	EQ bias CAL-3 output for auto calibration.
56	A CAP. M	O	Capastan motor ON/OFF control at deck-A. H : ON.
57	B CAP. M	O	Capastan motor ON/OFF control at deck-B. H : ON.
58	CAP. M H/L	O	Capastan motor high/normal selector. L : High.
59	PITCH. CON ON/OFF	O	Pitch control ON/OFF. H : ON.
60	LINE MUTE	O	Line mute ON/OFF output. L : Mute.
61 - 77	P17 - P1	O	VFD segment drive.
78 - 85	G1 - G8	O	VFD grid drive.
86	G6, G7	O	
87	G7, G8	O	
88	VFDP	-	VFD power. (- 28V)
89	VDD	-	Power supply. (+5V)
90	NC	-	Not used. (VDD connection)
91	Vss	-	Ground.
92	REEL B +	O	Reel motor (+) output at deck-B.
93	REEL B -	O	Reel motor (-) output at deck-B.
94	REEL A +	O	Reel motor (+) output at deck-A.
95	REEL A -	O	Reel motor (-) output at deck-A.
96	A T-REEL OUT	O	Take-up reel rotation detection at deck-A.
97	A T-REEL IN	I	Take-up reel rotation detection at deck-A.
98	A S-REEL OUT	O	Supply reel rotation detection at deck-B.
99	A S-REEL OUT	I	Supply reel rotation detection at deck-B.
100	A HALF	I	Half pawl input at deck-A. L : with claw.



SECTION 5  
DIAGRAMS

5-1. BLOCK DIAGRAM

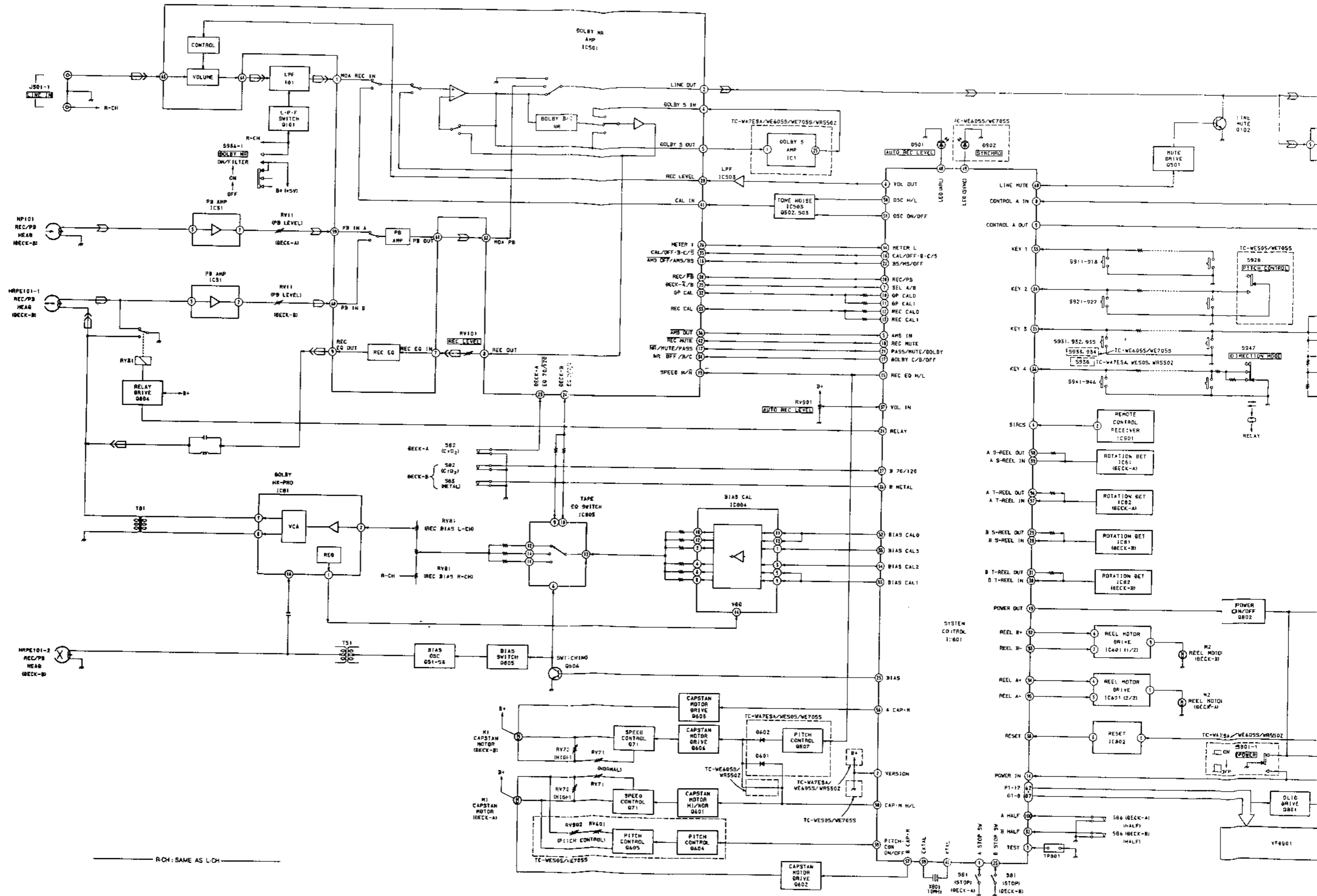

● CIRCUIT BOARDS LOCATION

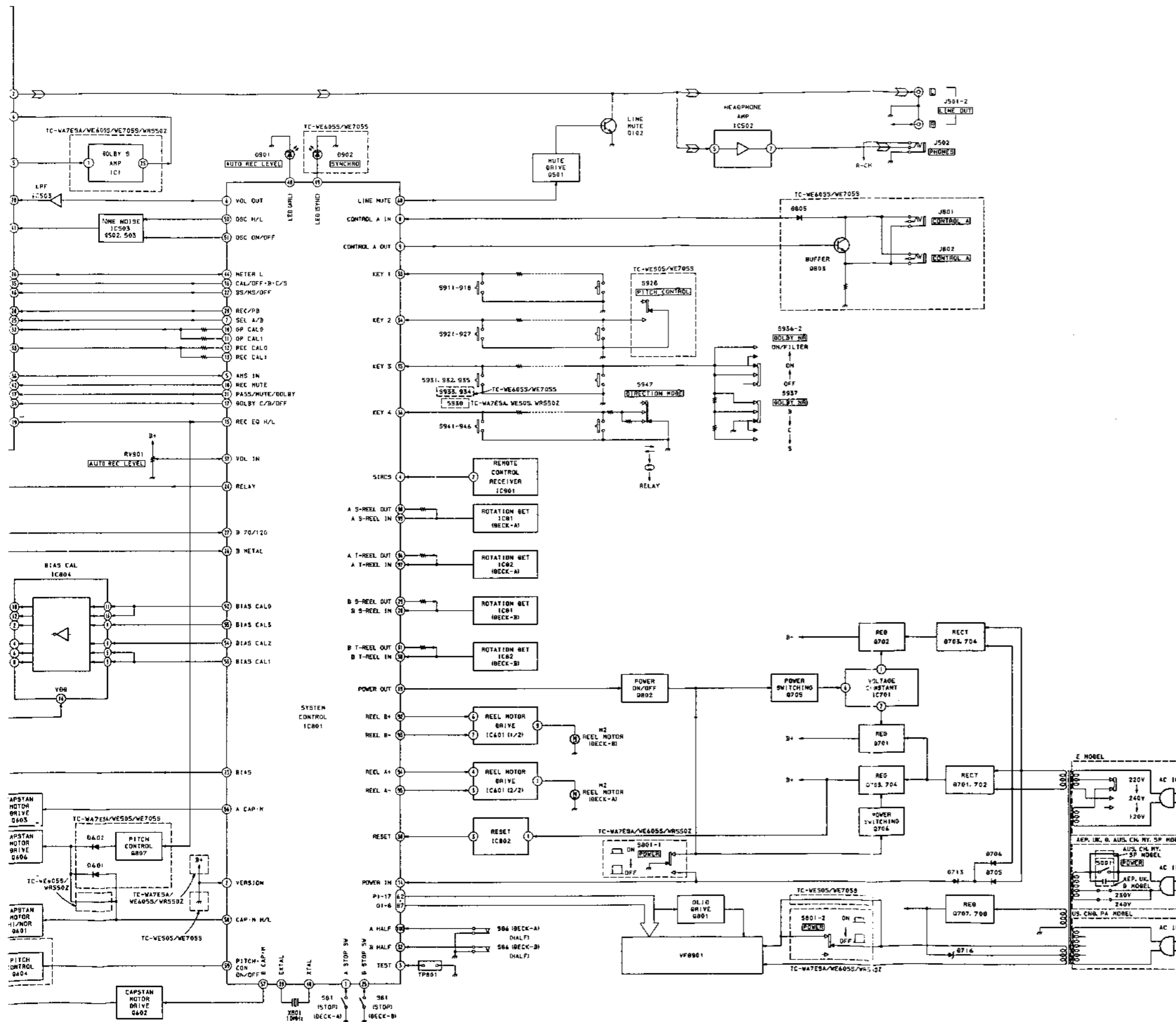

AUDIO board (DEC)

LEAF SW board (DECK-A)

DIRECTION board (WA7ESA, WE605S, WR550Z)

POWER SWITCH board (WE505, WE705S)

DIRECTION board (WE505, WE705S)

- Signal path.
- ◁ : PB (DECK A)
- ◻ : PB (DECK B)
- ◁ : REC (DECK B)
- Abbreviation
- CND : Canadian
- G : German
- AUS : Australian
- CH : Chinese
- SP : Singapore
- MY : Malaysia
- PA : Panama

• CIRCUIT BOARDS LOCATION

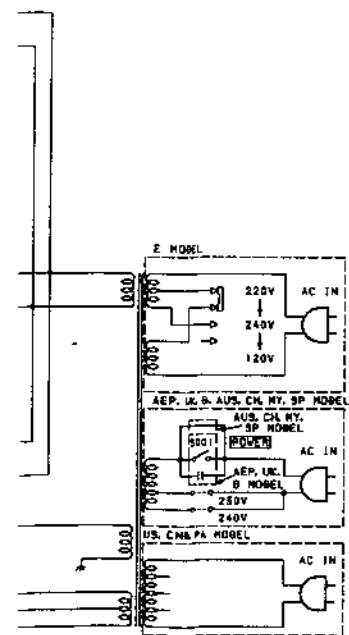
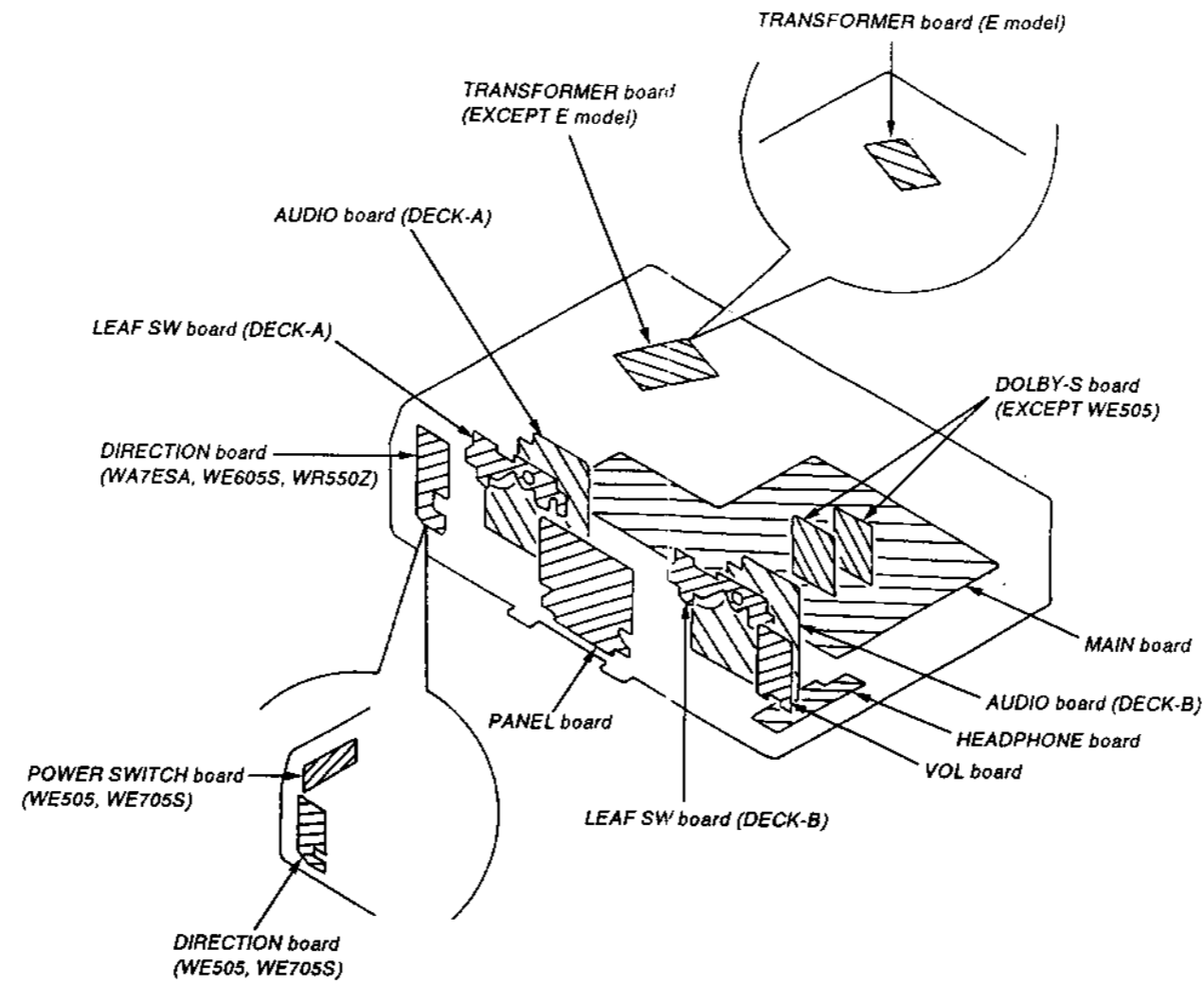

• Signal path.

- : PB (DECK A)
- : PB (DECK B)
- : REC (DECK B)

• Abbreviation

- CND : Canadian
- G : German
- AUS : Australian
- CH : Chinese
- SP : Singapore
- MY : Malaysia
- PA : Panama

5-2. PRINTED WIRING BOARDS (MAIN SECTION)

◆ SEMICONDUCTOR LOCATION

Ref. No.	Location	Ref. No.	Location
D101	G-13	IC801	F-14
D201	G-13	IC802	G-13
D521	C-9	IC804	H-12
D522	C-9	IC805	H-11
D601	H-17	IC901	H-2
D602	H-17	Q101	G-9
D701	B-16	Q102	B-10
D702	B-16	Q201	E-9
D703	C-16	Q202	B-10
D704	C-16	Q501	B-13
D705	B-16	Q502	G-9
D706	B-16	Q503	G-9
D707	D-16	Q601	H-17
D708	B-14	Q602	H-18
D709	B-14	Q603	H-17
D710	B-14	Q604	H-17
D711	C-14	Q605	G-19
D712	B-16	Q606	H-17
D713	D-16	Q701	B-15
D714	D-16	Q702	D-14
D715	D-15	Q703	B-16
D716	D-15	Q704	B-16
D801	G-15	Q705	B-14
D802	G-15	Q706	B-16
D803	G-16	Q707	D-16
D804	G-16	Q708	D-15
D805	E-15	Q709	B-14
D901	D-5	Q801	G-15
D902	B-2	Q802	E-16
IC501	E-10	Q804	E-12
IC502	B-12	Q805	G-11
IC503	B-9	Q806	G-11
IC601	F-18	Q807	H-17
IC701	G-14		

Note:

- : parts extracted from the component side.
- ▨ : Pattern on the side which is seen.

Abbreviation

- CND : Canadian
- G : German
- AUS : Australian
- CH : Chinese
- SP : Singapore
- MY : Malaysia
- PA : Panama

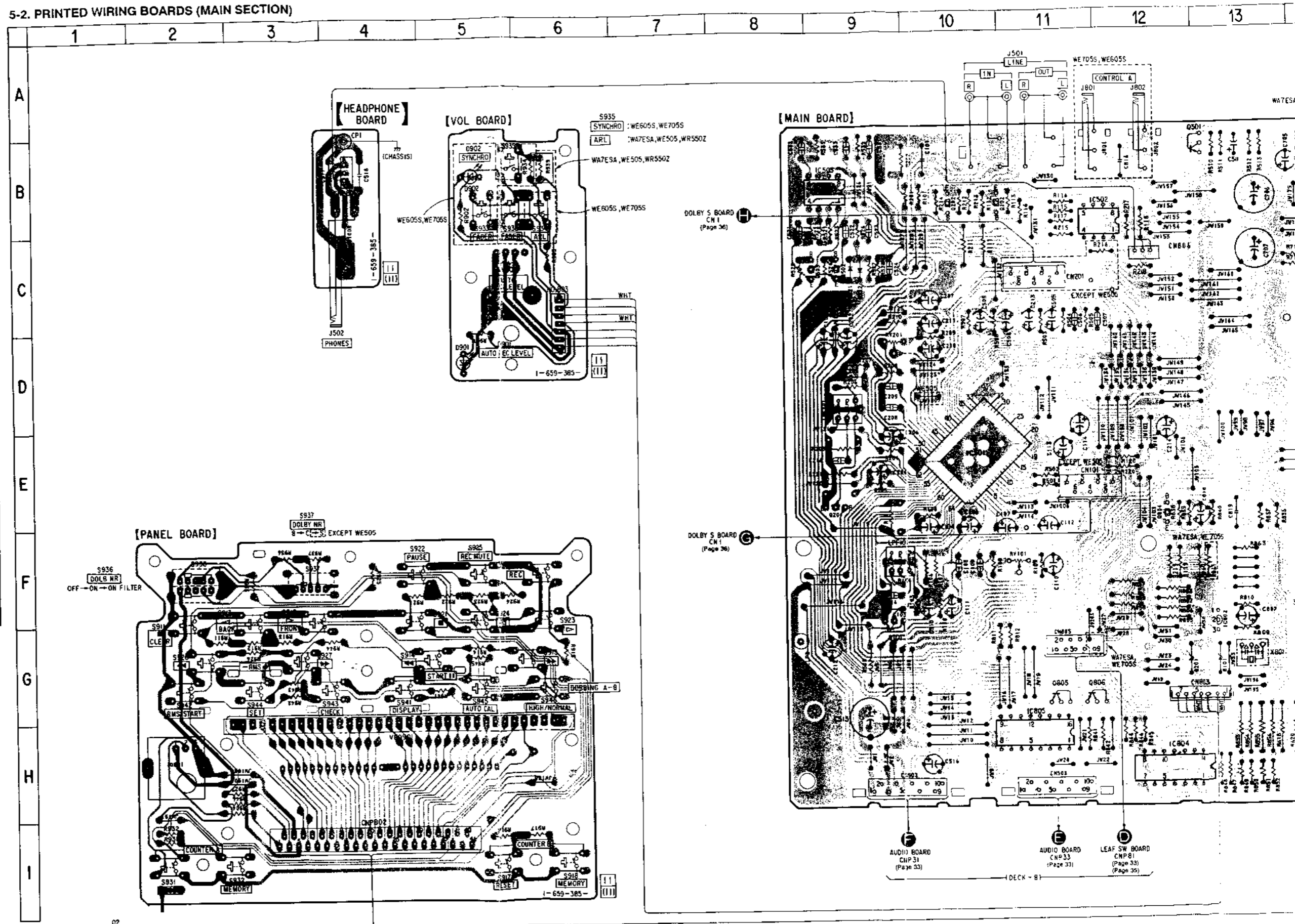

02

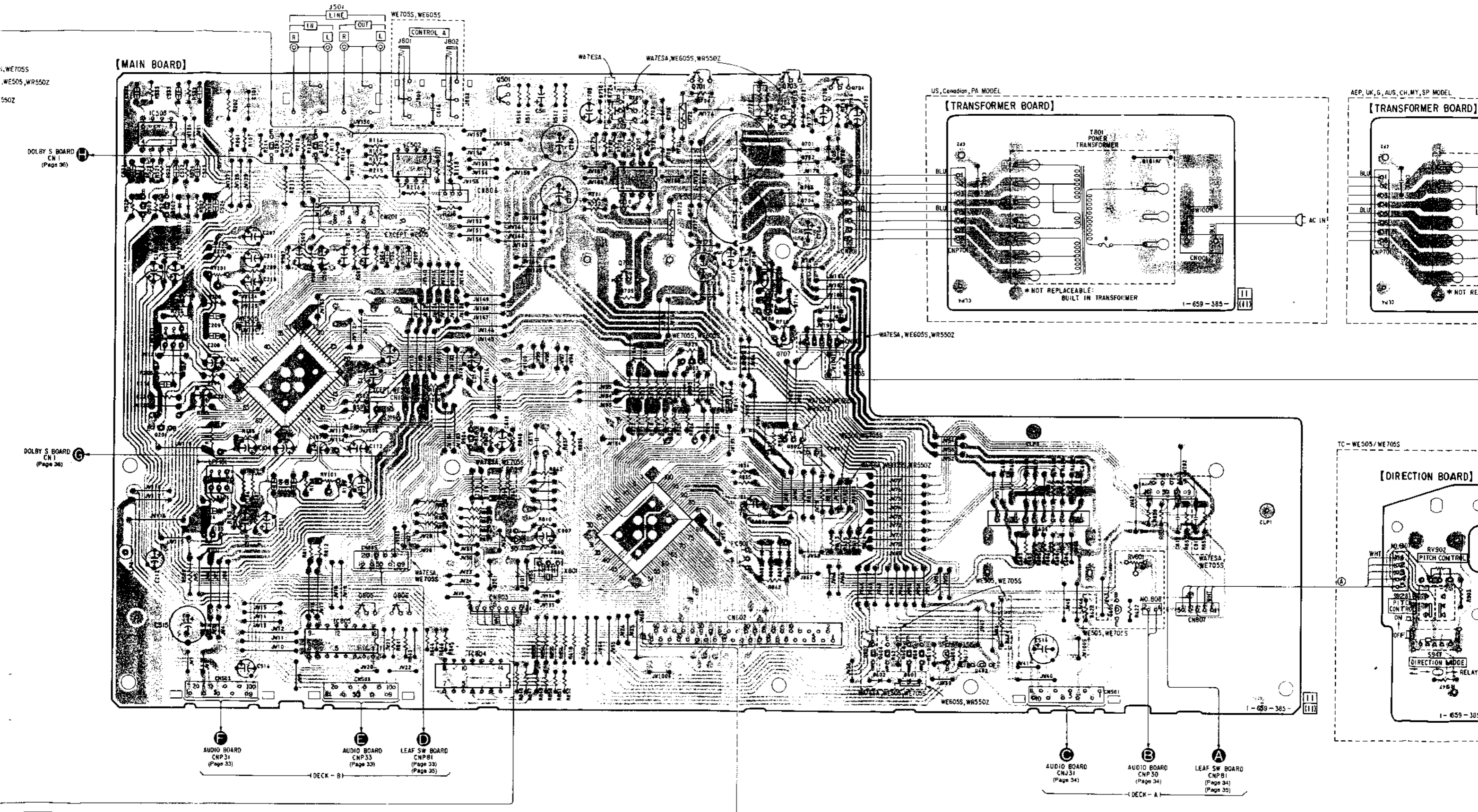

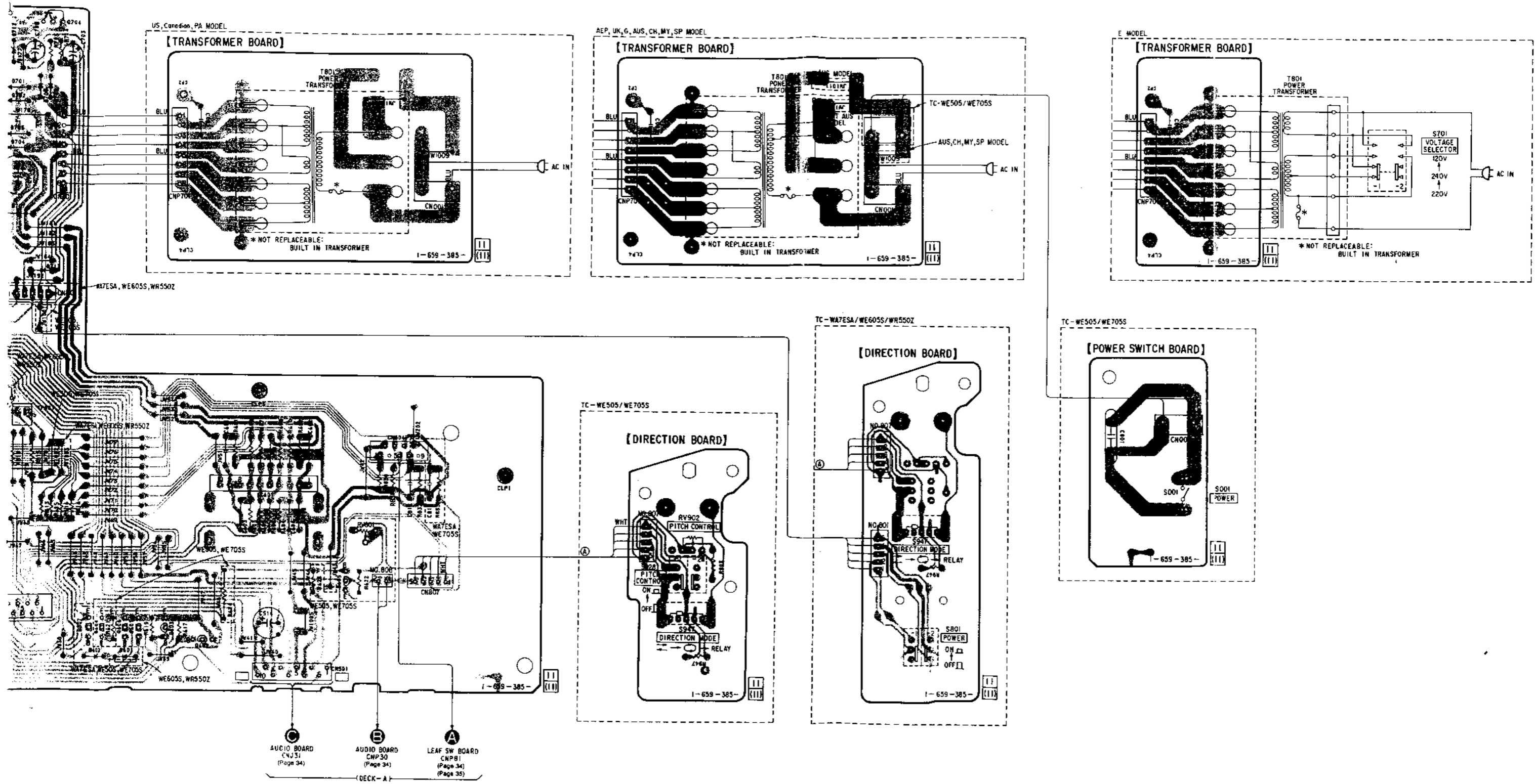



5-3. SCHEMATIC DIAGRAM (MAIN SECTION)

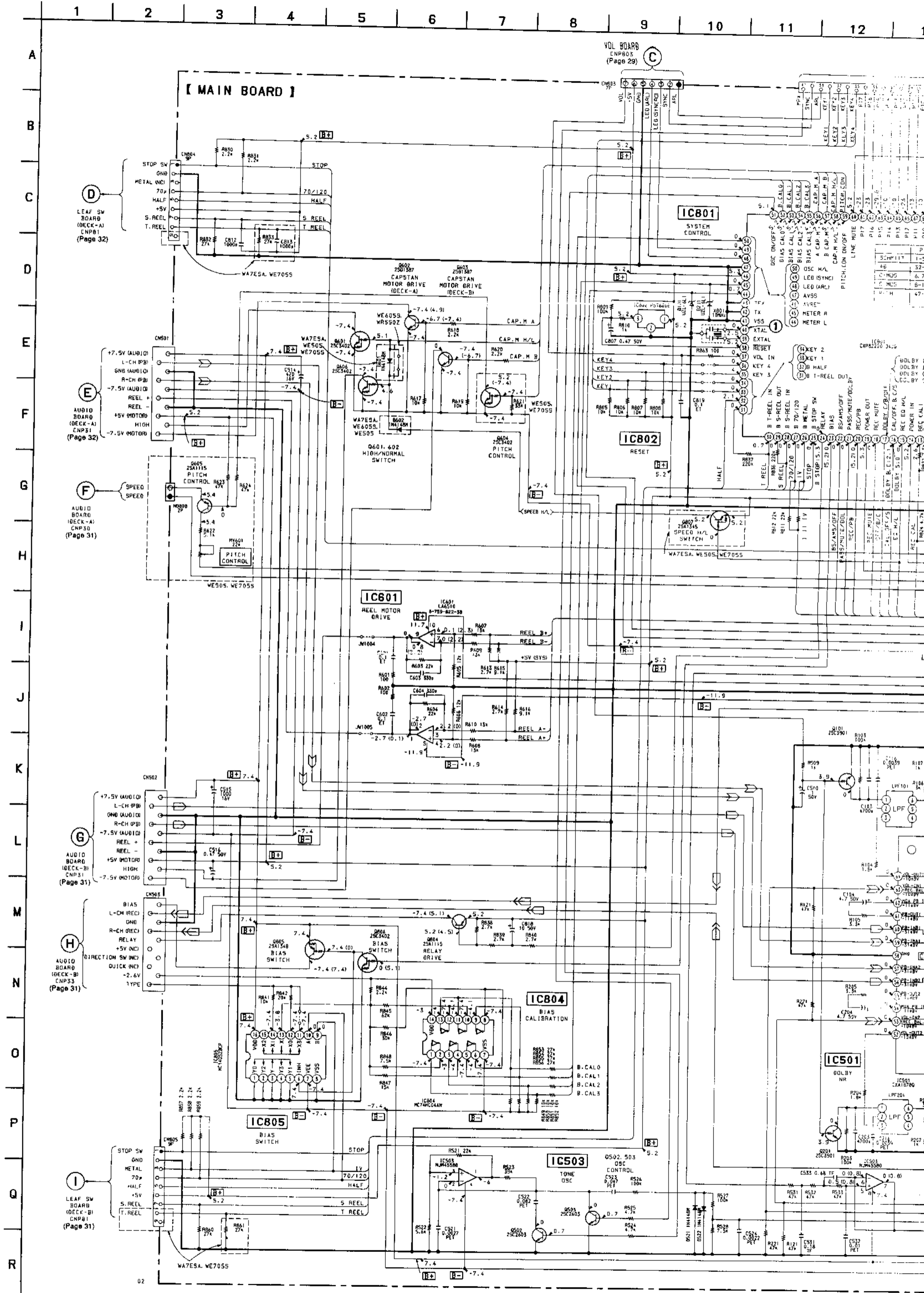



VOL BOARD  
CNP803  
(Page 29)

PANEL BOARD  
CNP802  
(Page 29)

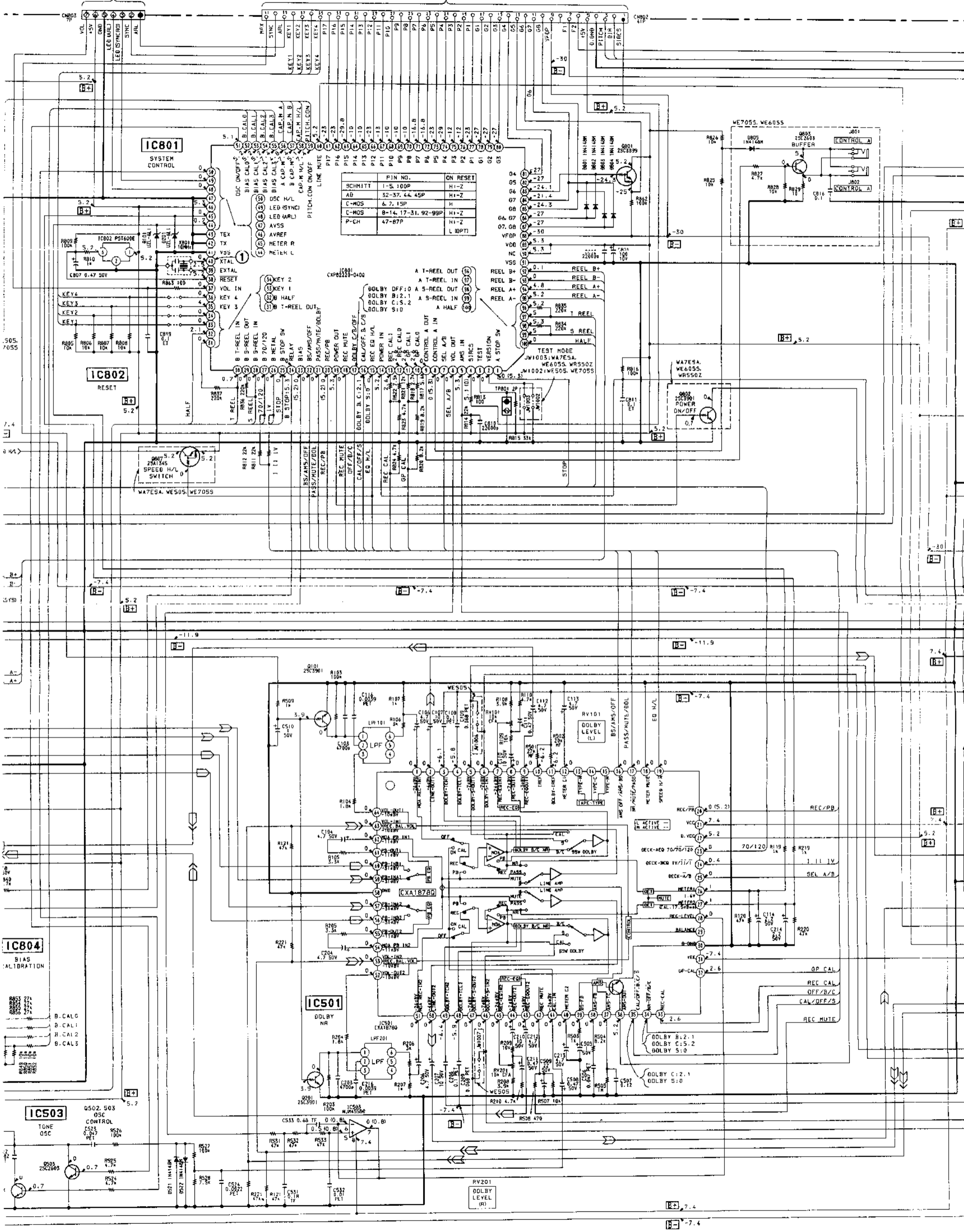

505, 7055  
7.4  
0.7

IC804  
BIAS  
CALIBRATION

IC503  
Q502, 503  
TONE  
OSC  
OSC  
CONTROL

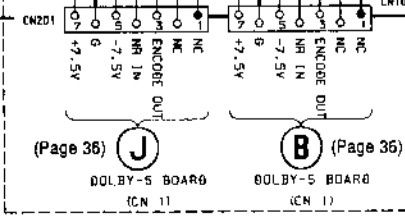
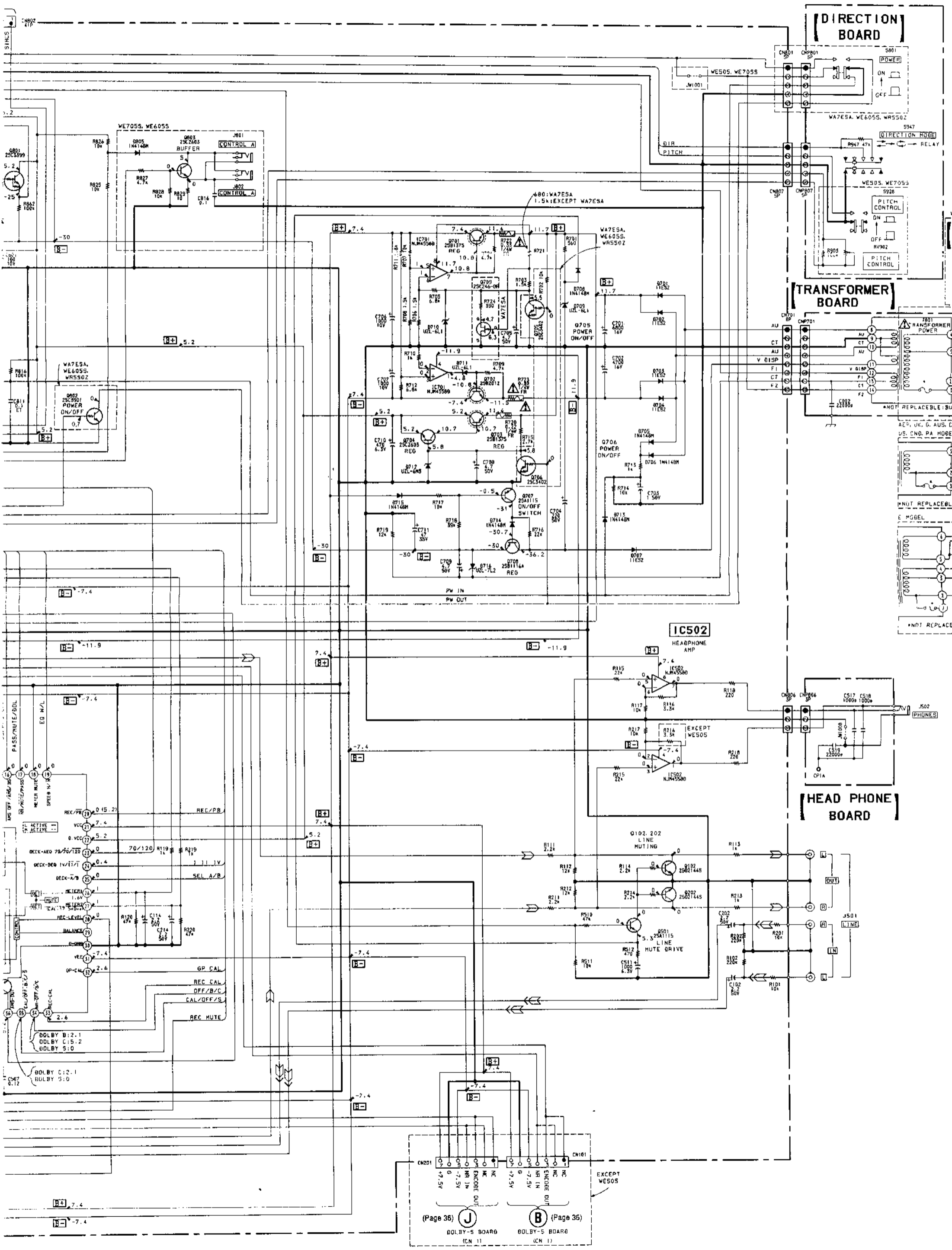

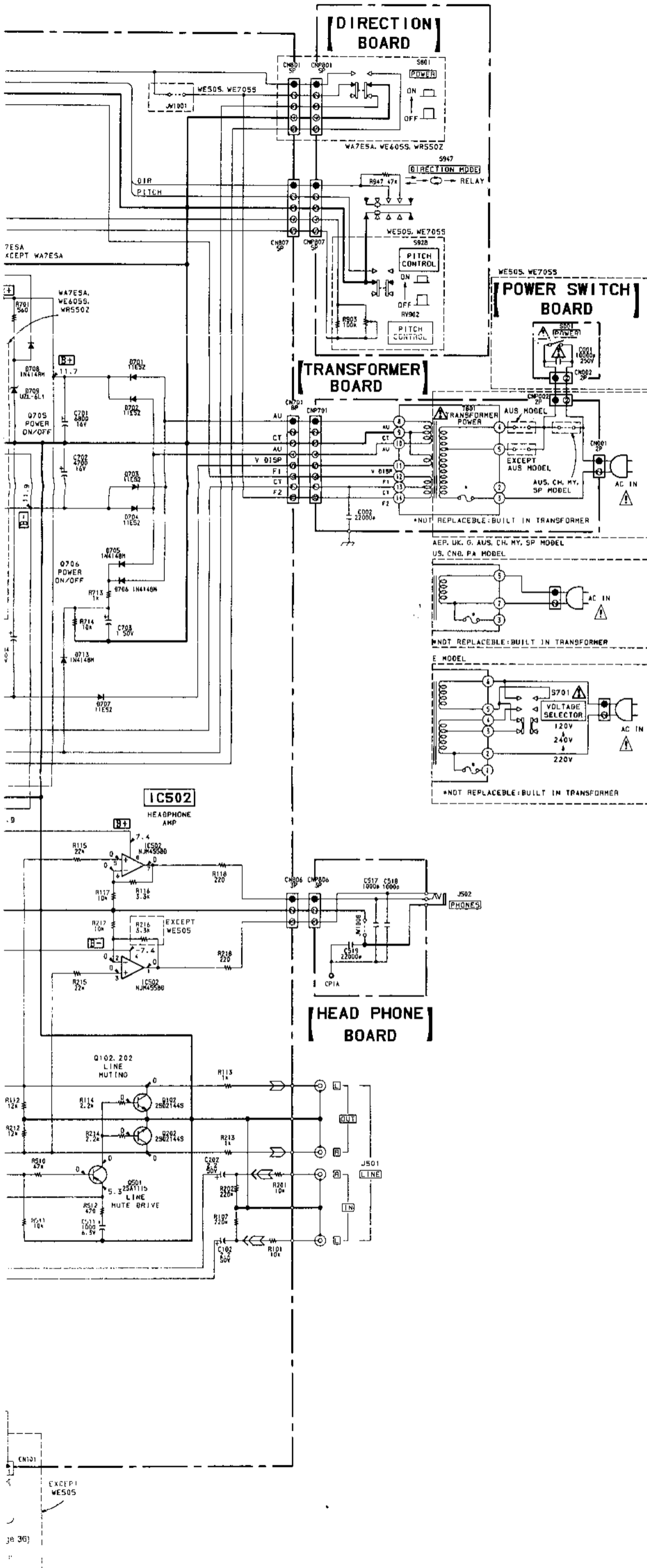

• WAVEFORM - MAIN SECTION -

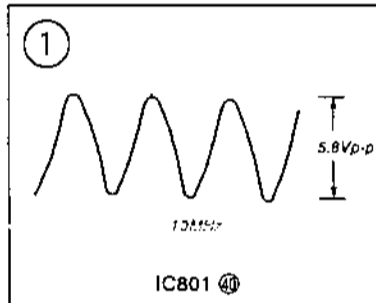

Note :

- All capacitors are in  $\mu F$  unless otherwise noted. pF:  $\mu \mu F$  50WV or less are not indicated except for electrolytics and tantalums.
- All resistors are in  $\Omega$  and  $\frac{1}{4}W$  or less unless otherwise specified.
- $\Delta$  : internal component.
- $\text{---}\text{---}$  : fusible resistor.

<p><b>Note :</b> The components identified by mark <math>\Delta</math> or dotted line with mark <math>\Delta</math> are critical for safety. Replace only with part number specified.</p>	<p><b>Note :</b> Les composants identifiés par une marque <math>\Delta</math> sont critiques pour la sécurité. Ne les remplacer que par une pièce portant le numéro spécifié.</p>
---	---

- **B+** : B+ Line
- **B-** : B- Line
- $\text{---}\text{---}$  : adjustment for repair.
- Voltage and waveforms are dc with respect to ground under no-signal conditions.  
no mark : STOP  
( ) : REC
- Voltages are taken with a VOM ( Input impedance 10M  $\Omega$  ). Voltage variations may be noted due to normal production tolerances.
- Waveforms are taken with a oscilloscope. Voltage variations may be noted due to normal production tolerances.
- Circled numbers refer to waveforms.
- Signal path.  
  - $\text{---}\text{---}$  : PB ( DECK A )
  - $\text{---}\text{---}$  : PB ( DECK B )
  - $\text{---}\text{---}$  : REC ( DECK B )
- Abbreviation  
  - CND : Canadian
  - G : German
  - AUS : Australian
  - CH : Chinese
  - SP : Singapore
  - MY : Malaysia
  - PA : Panama



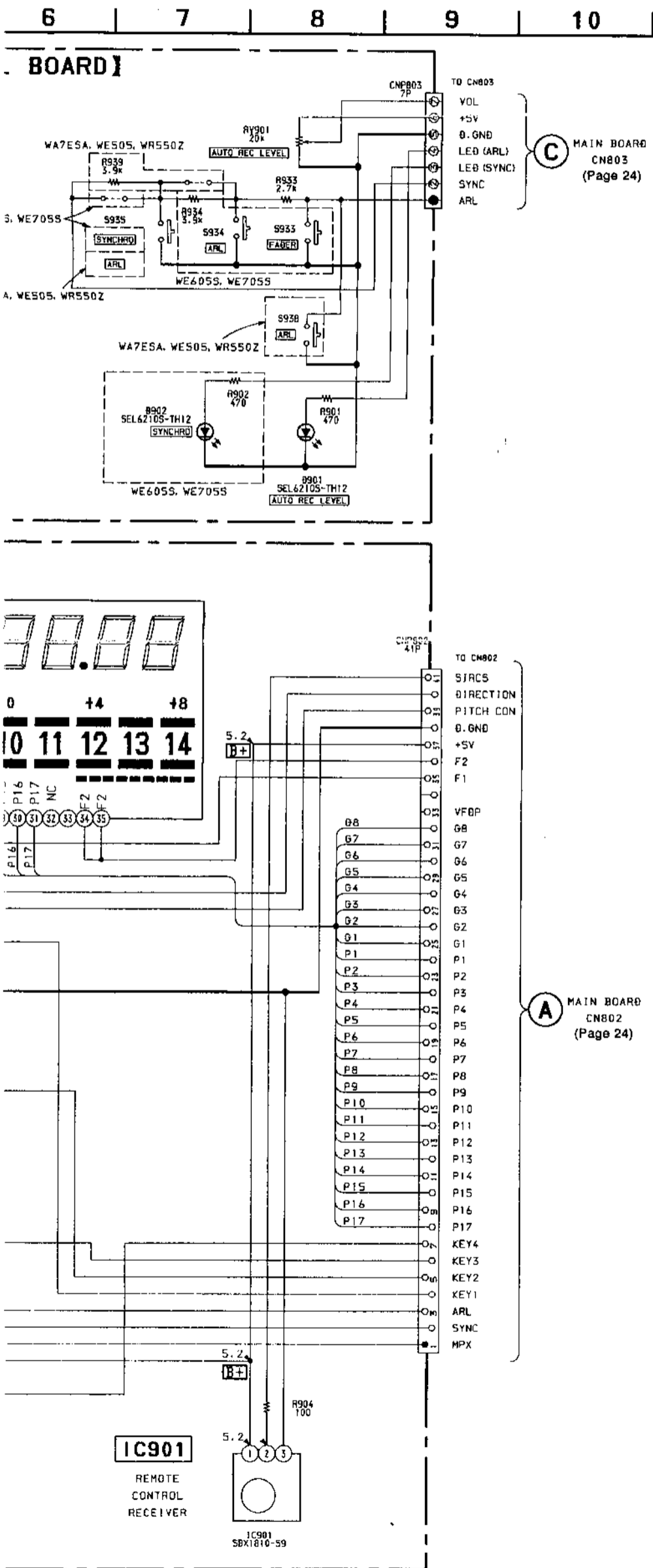

5-5. SCHEMATIC DIAGRAM (AUDIO SECTION)

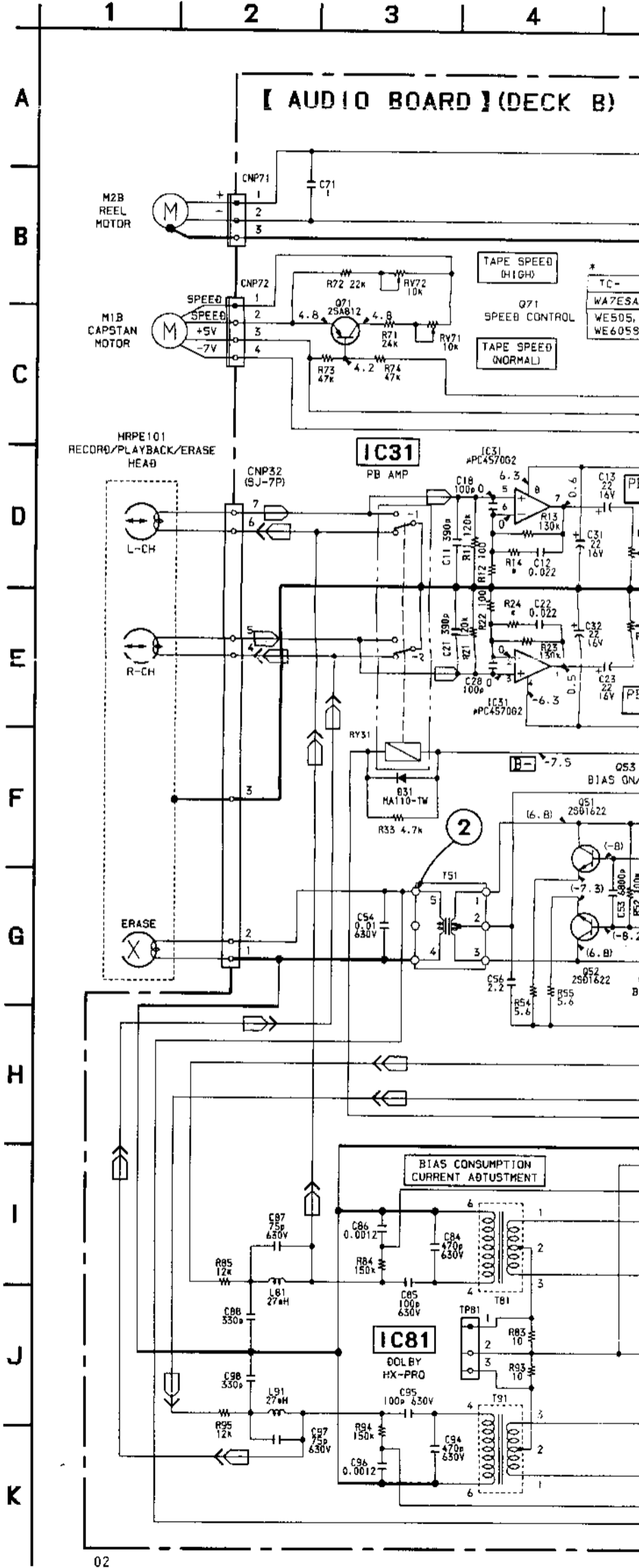

**Note :**

- All capacitors are in  $\mu F$  unless otherwise noted. pF:  $\mu F$  50WV or less are not indicated except for electrolytics and tantalums.
- All resistors are in  $\Omega$  and  $\frac{1}{4}W$  or less unless otherwise specified.
- **B+** : B+ Line
- **B-** : B- Line
- : adjustment for repair.
- Voltage and waveforms are dc with respect to ground under no-signal conditions.  
no mark : STOP  
( ) : REC
- Voltages are taken with a VOM ( Input impedance  $10M \Omega$  ).  
Voltage variations may be noted due to normal production tolerances.

- Waveforms are taken with a oscilloscope.  
Voltage variations may be noted due to normal production tolerances.
- Circled numbers refer to waveforms
- Signal path.
- ▷ : PB ( DECK A )
- ◁ : PB ( DECK B )
- ◁▷ : REC ( DECK B )

3      4      5      6      7      8      9      10      11      12      13

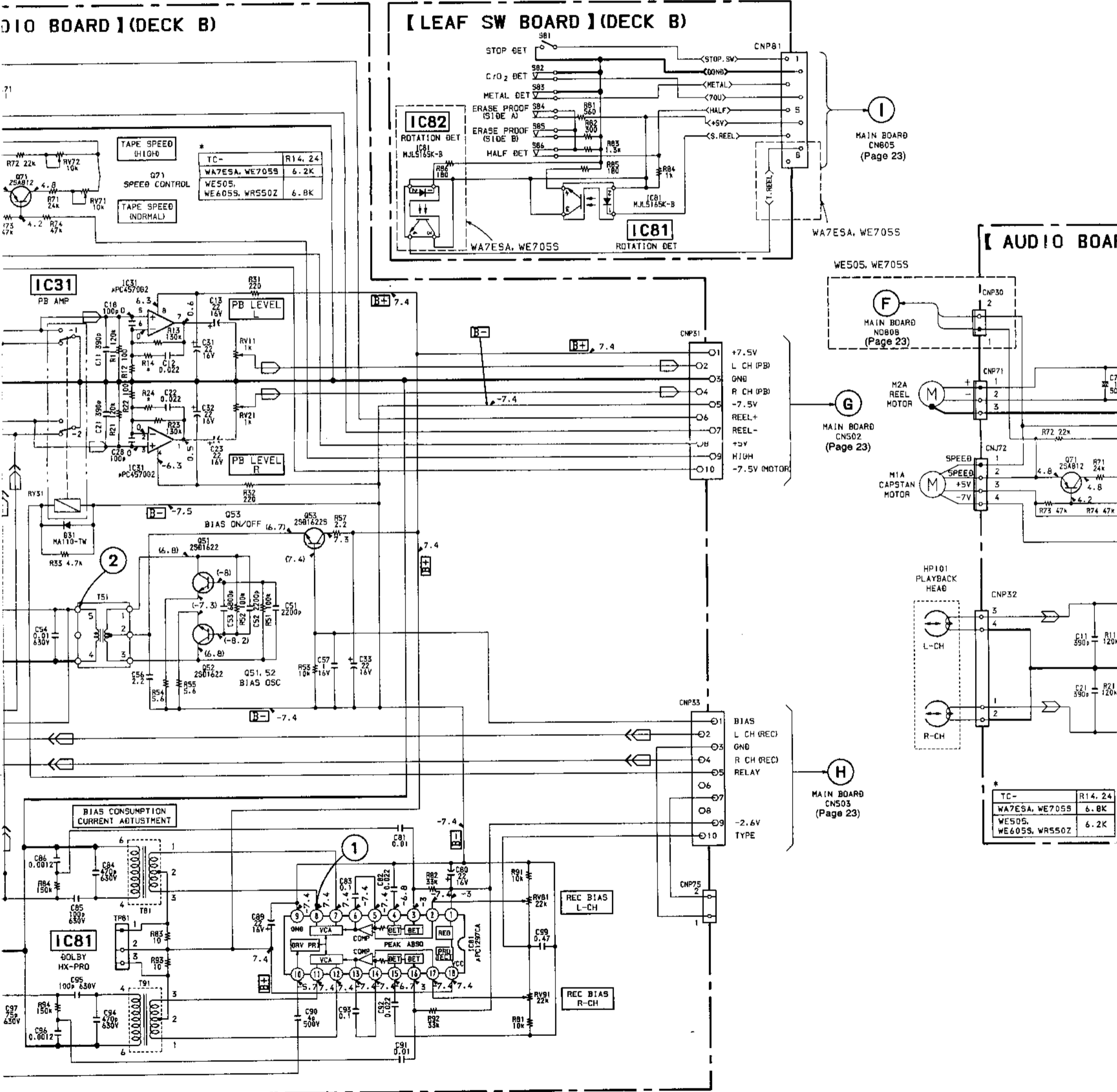

5-6. PRINTED WIRING BOARDS (AUDIO SECTION)

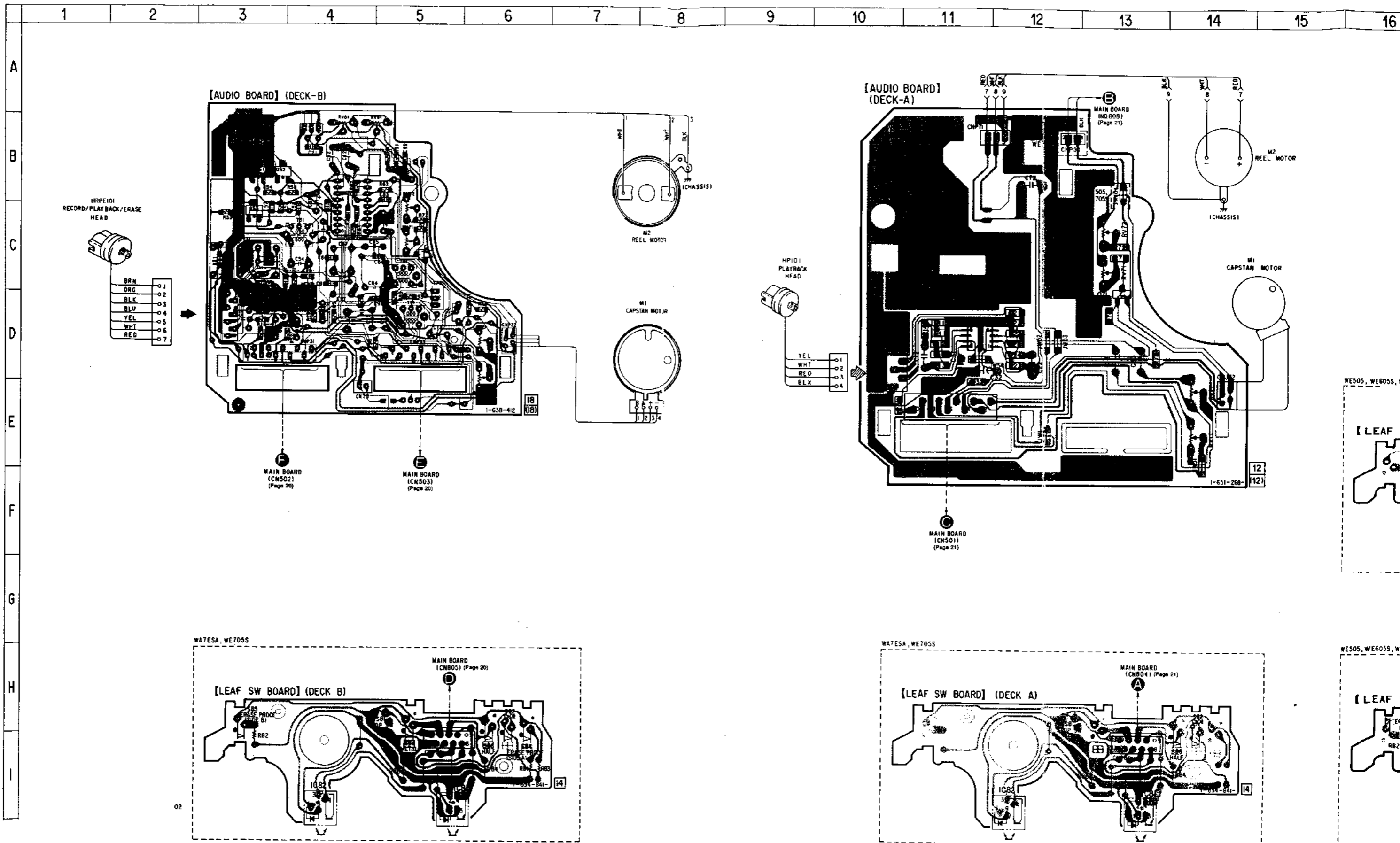

7 8 9 10 11 12 13 14 15 16 17 18 19 20

● SEMICONDUCTOR LOCATION (DECK-A)

Ref. No.	Location
IC31	D - 11
IC81 (LEAF SW)	F - 18
IC81 (LEAF SW)	I - 13
IC82 (LEAF SW)	I - 12
Q71	C - 13

(DECK-B)

Ref. No.	Location
D31	C - 3
IC31	D - 4
IC81 (AUDIO)	B - 4
IC81 (LEAF SW)	I - 5
IC81 (LEAF SW)	I - 18
IC82 (LEAF SW)	I - 4
Q51	B - 3
Q52	B - 3
Q53	C - 3
Q71	C - 5

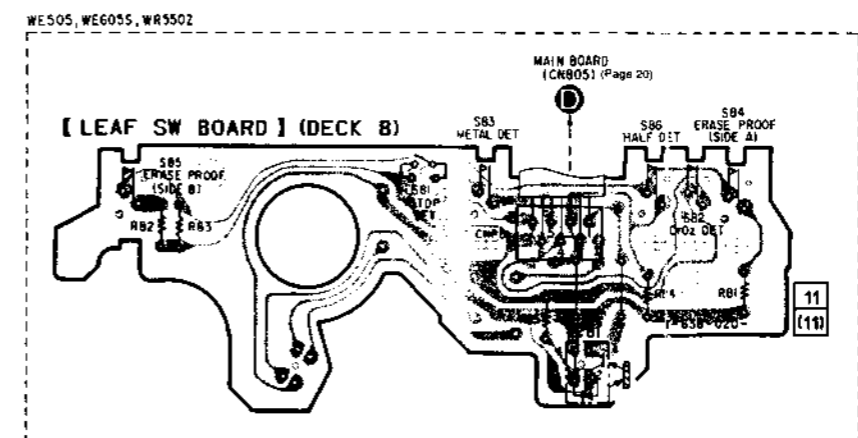
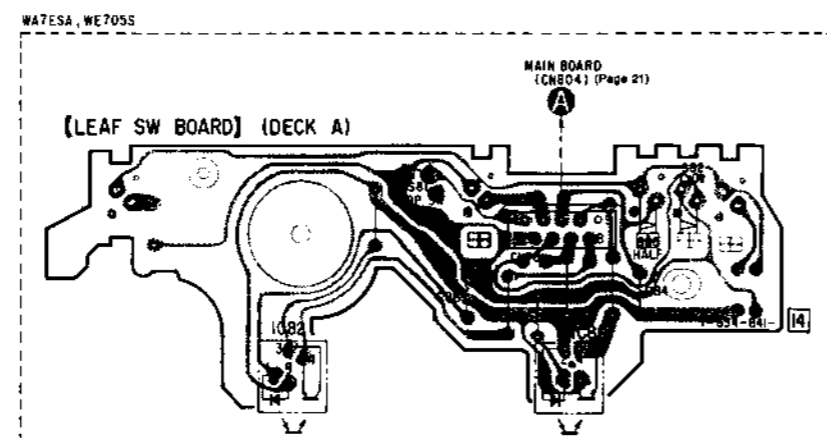
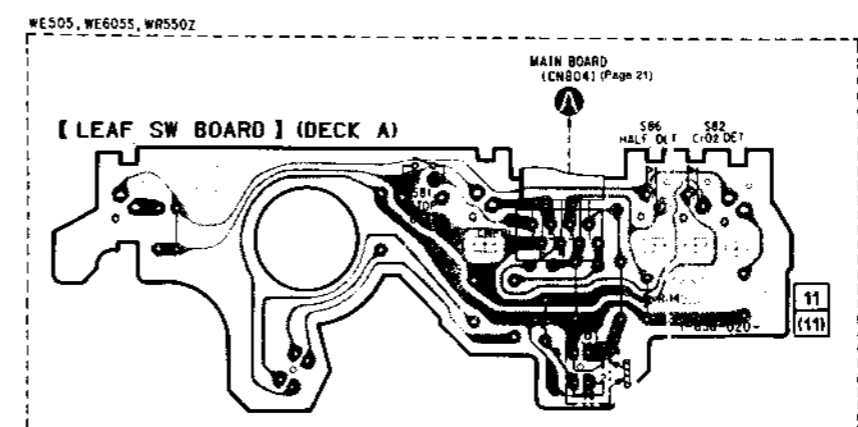
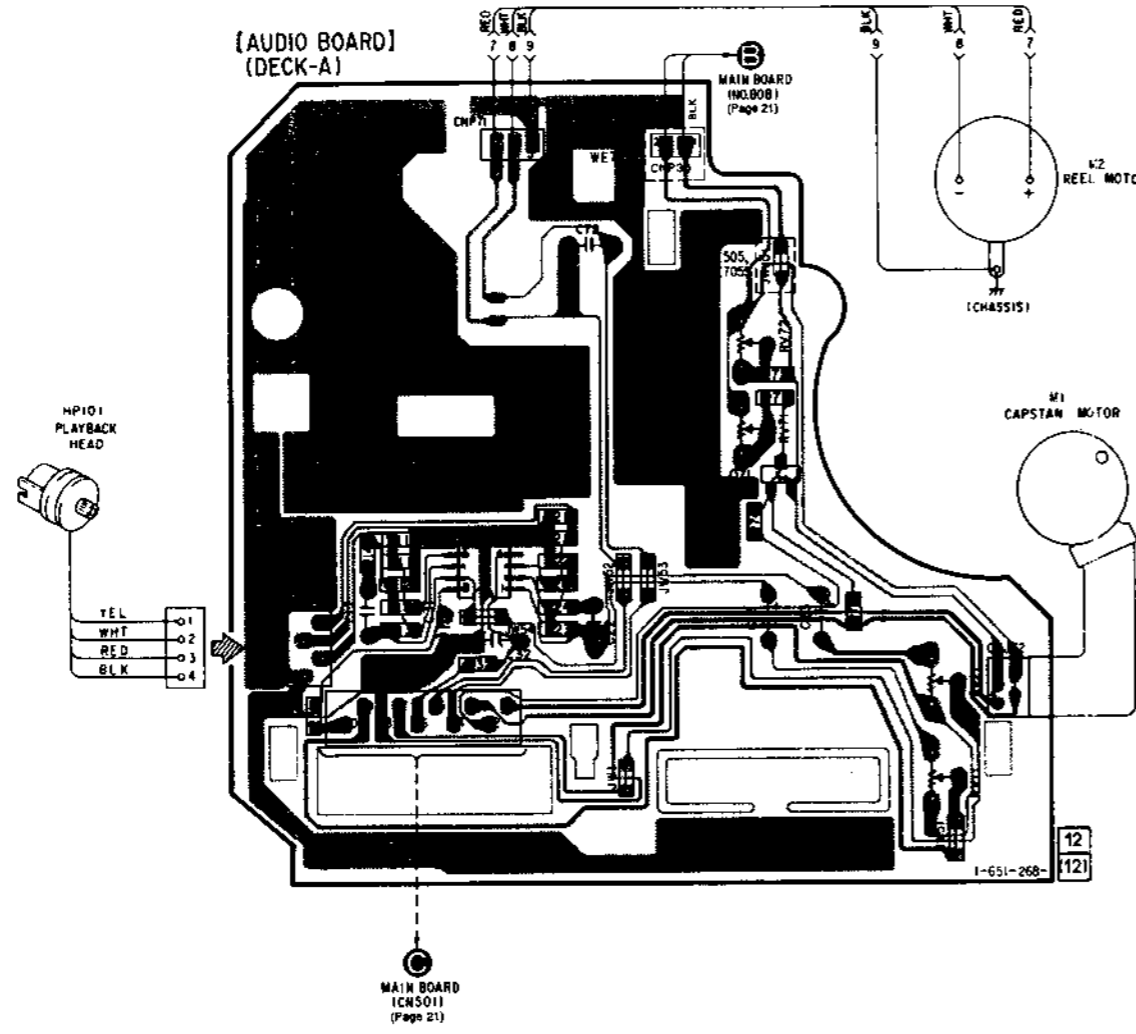

Note:

- : parts extracted from the component side.
- : Through hole.
- ▨ : Pattern on the side which is seen.
- ▧ : Pattern of the rear side.



5-7. PRINTED WIRING BOARDS (DOLBY SECTION)  
(EXCEPT WE505)

[DOLBY S BOARD]

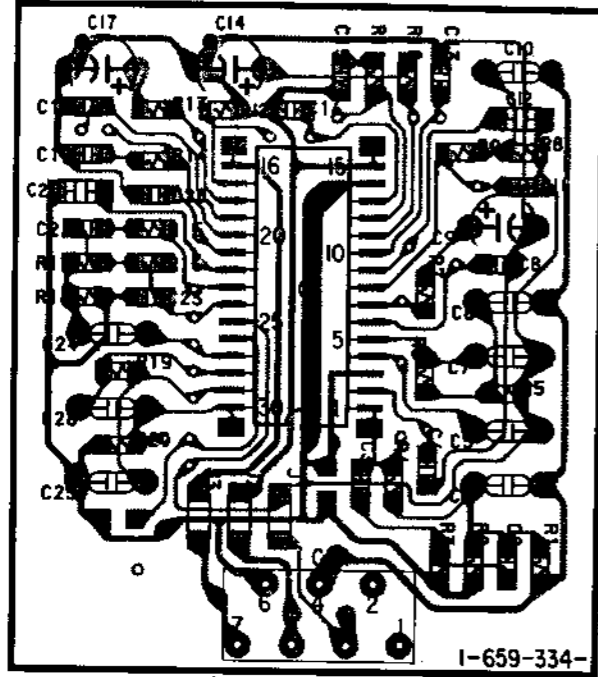

(Page 19) **G** **H** (Page 19)  
MAIN BOARD  
CN101, 201

Note:  
• ○ : parts extracted from the component side.  
• ▨ : Pattern on the side which is seen.

5-8. SCHEMATIC DIAGRAM (DOLBY SECTION)  
(EXCEPT WE505)

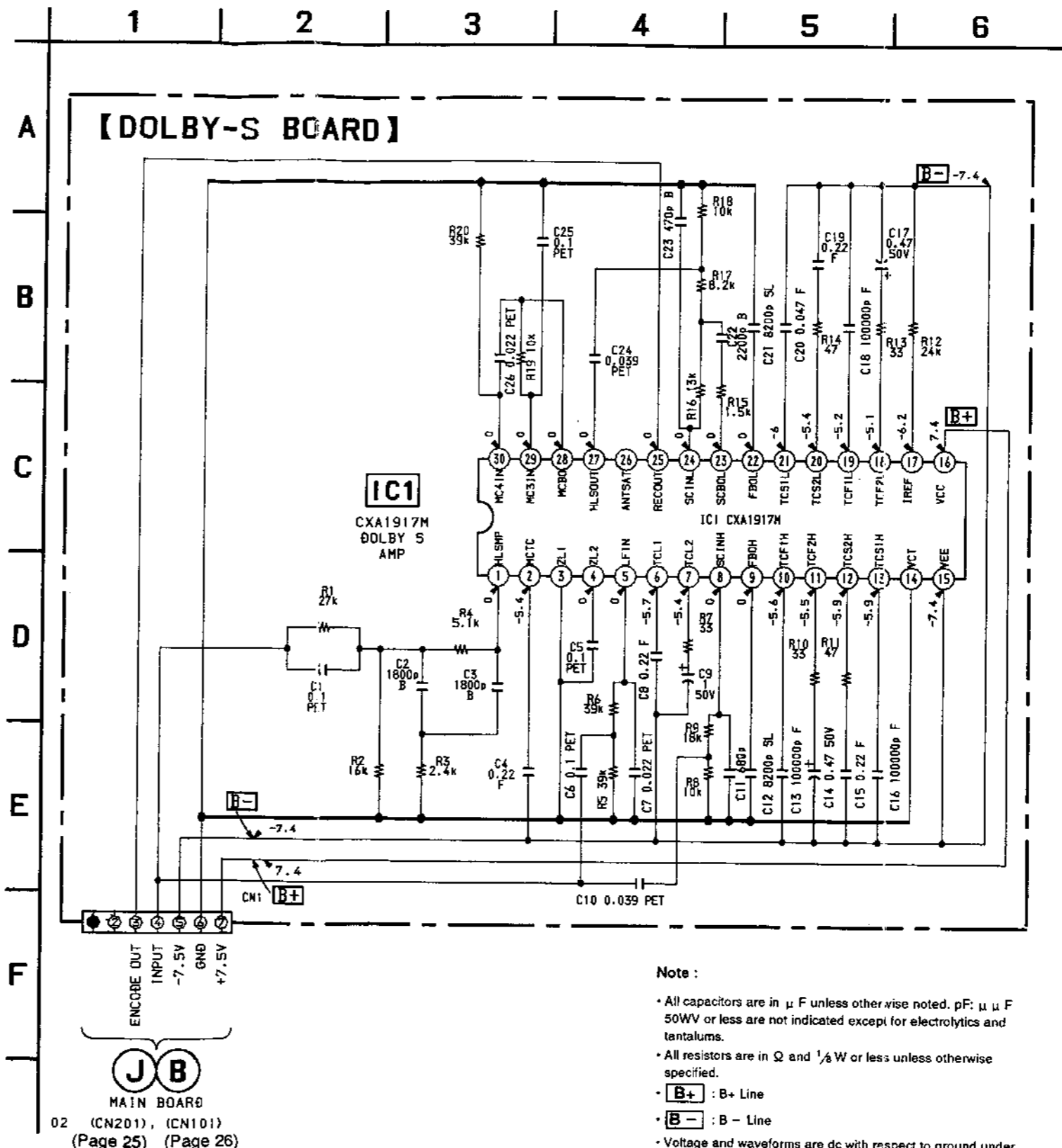

Note :

- All capacitors are in  $\mu$  F unless otherwise noted. pF:  $\mu$   $\mu$  F 50WV or less are not indicated except for electrolytics and tantalums.
- All resistors are in  $\Omega$  and  $\frac{1}{8}$  W or less unless otherwise specified.
- **B+** : B+ Line
- **B-** : B - Line
- Voltage and waveforms are dc with respect to ground under no-signal conditions.  
no mark : STOP
- Voltages are taken with a VOM (Input impedance 10M  $\Omega$ ). Voltage variations may be noted due to normal production tolerances.
- Voltage variations may be noted due to normal production tolerances.

• IC BLOCK DIAGR.  
IC1 CXA1917M-T6

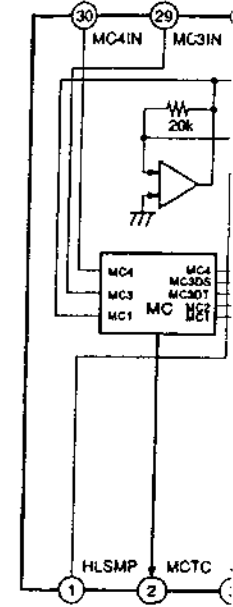

1      2      3      4      5      6

**DOLBY-S BOARD**

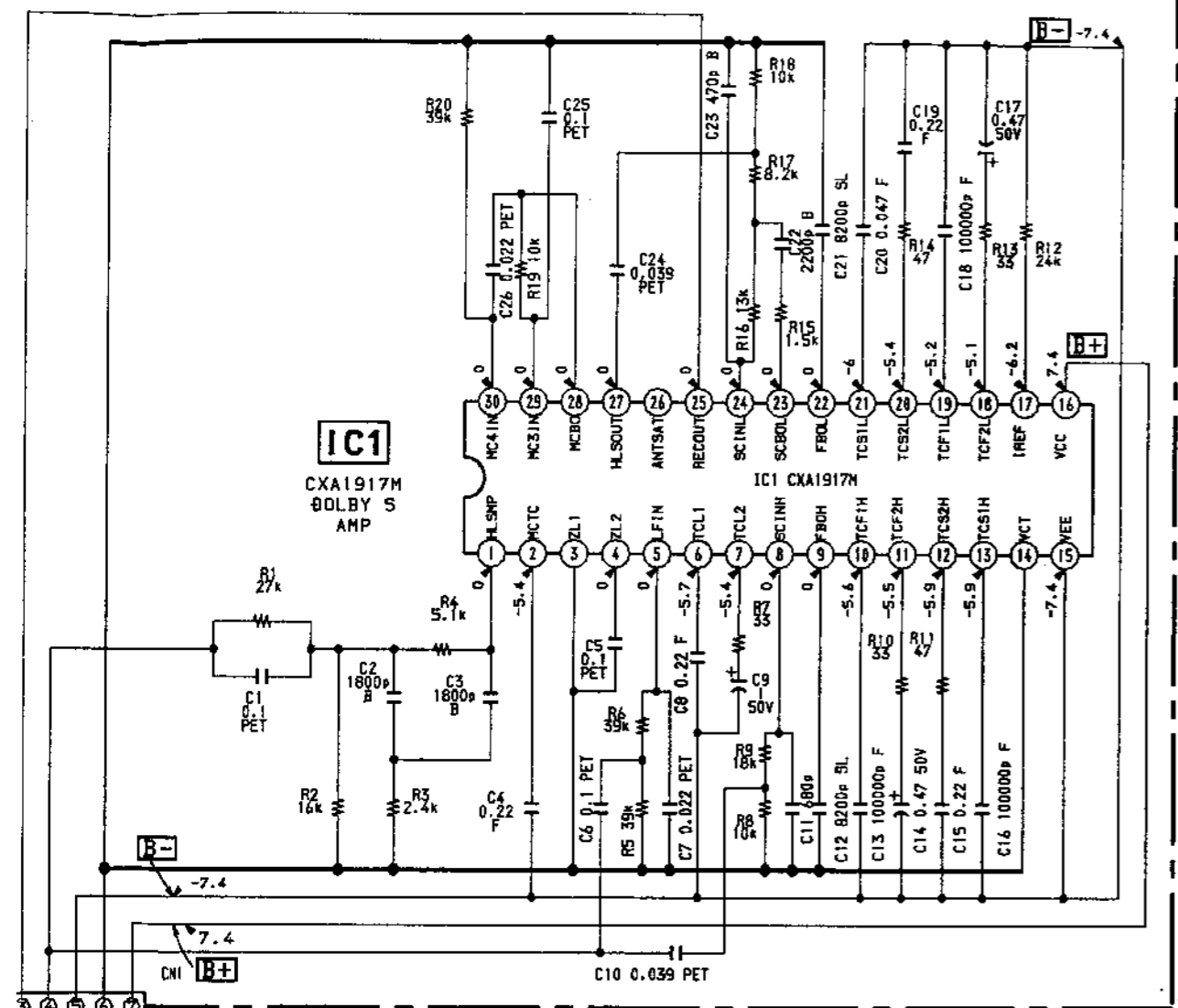

ENCORE OUT  
INPUT  
-7.5V  
GND  
+7.5V

**JB**  
IN BOARD  
1) (CN101)  
5) (Page 26)

- Note :**
- All capacitors are in  $\mu$  F unless otherwise noted, pF:  $\mu$   $\mu$  F 50WV or less are not indicated except for electrolytics and tantalums.
  - All resistors are in  $\Omega$  and  $1/8$  W or less unless otherwise specified.
  - **B+** : B+ Line
  - **B-** : B - Line
  - Voltage and waveforms are dc with respect to ground under no-signal conditions.  
no mark : STOP
  - Voltages are taken with a VOM ( Input impedance 10M  $\Omega$  ). Voltage variations may be noted due to normal production tolerances.
  - Voltage variations may be noted due to normal production tolerances.

• IC BLOCK DIAGRAM  
IC1 CXA1917M-T6

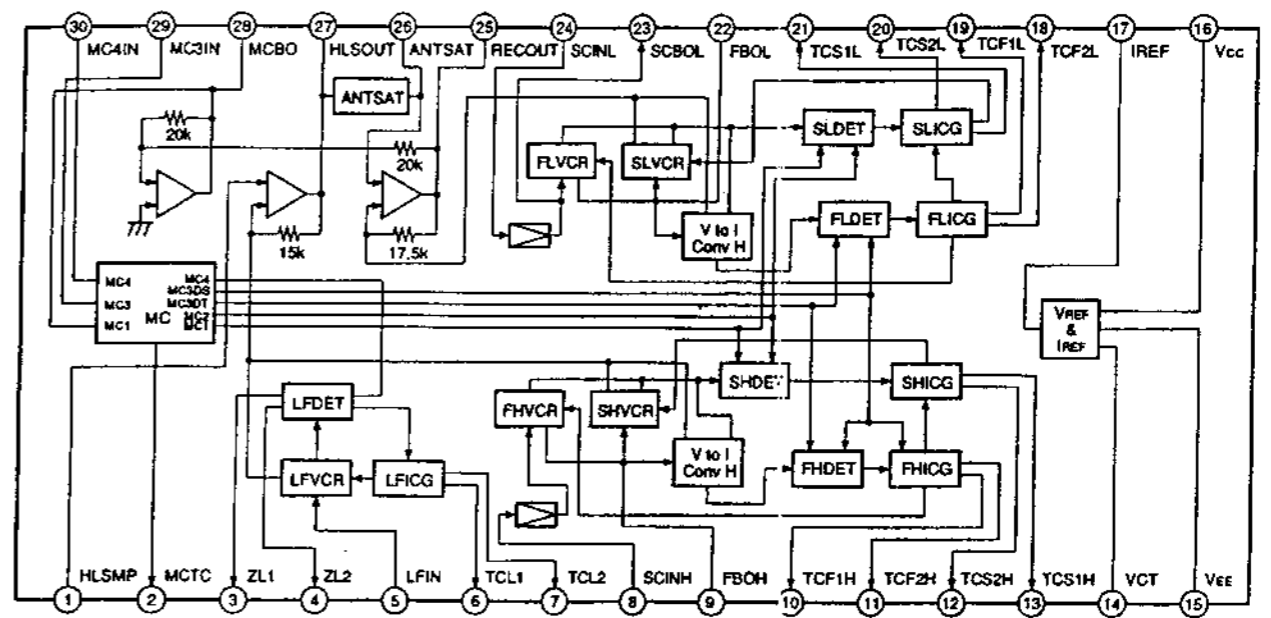

## SECTION 6 EXPLODED VIEWS

**NOTE :**

- -XX, -X mean standardized parts, so they may have some difference from the original one.
- Items marked "\*" are not stocked since they are seldom required for routine service. Some delay should be anticipated when ordering these items.

- The mechanical parts with no reference number in the exploded views are not supplied.
- Hardware (# mark) list and accessories and packing materials are given in the last of this parts list.

● Abbreviation

CND : Canadian	G : German
AUS : Australian	MY : Malaysia
SP : Singapore	CH : Chinese
PA : Panama	

The components identified by mark  $\Delta$  or dotted line with mark  $\Delta$  are critical for safety.  
Replace only with part number specified.

Les composants identifiés par une marque  $\Delta$  sont critiques pour la sécurité.  
Ne les remplacer que par une pièce portant le numéro spécifié.

**6-1. CHASSIS SECTION**

$\Delta$  A : TRANSFORMER BOARD

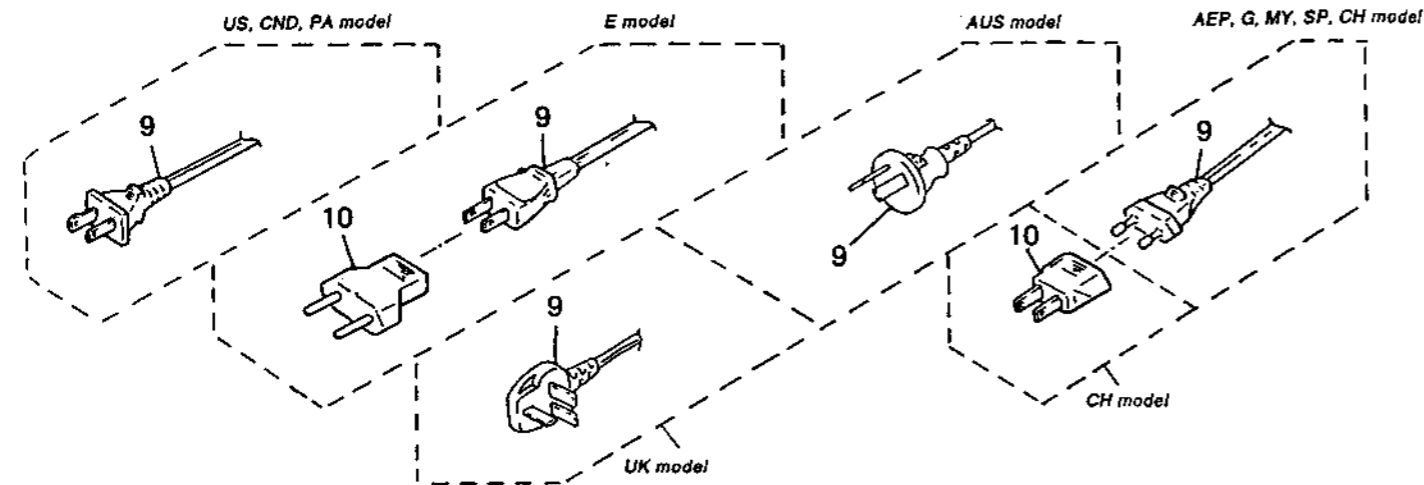
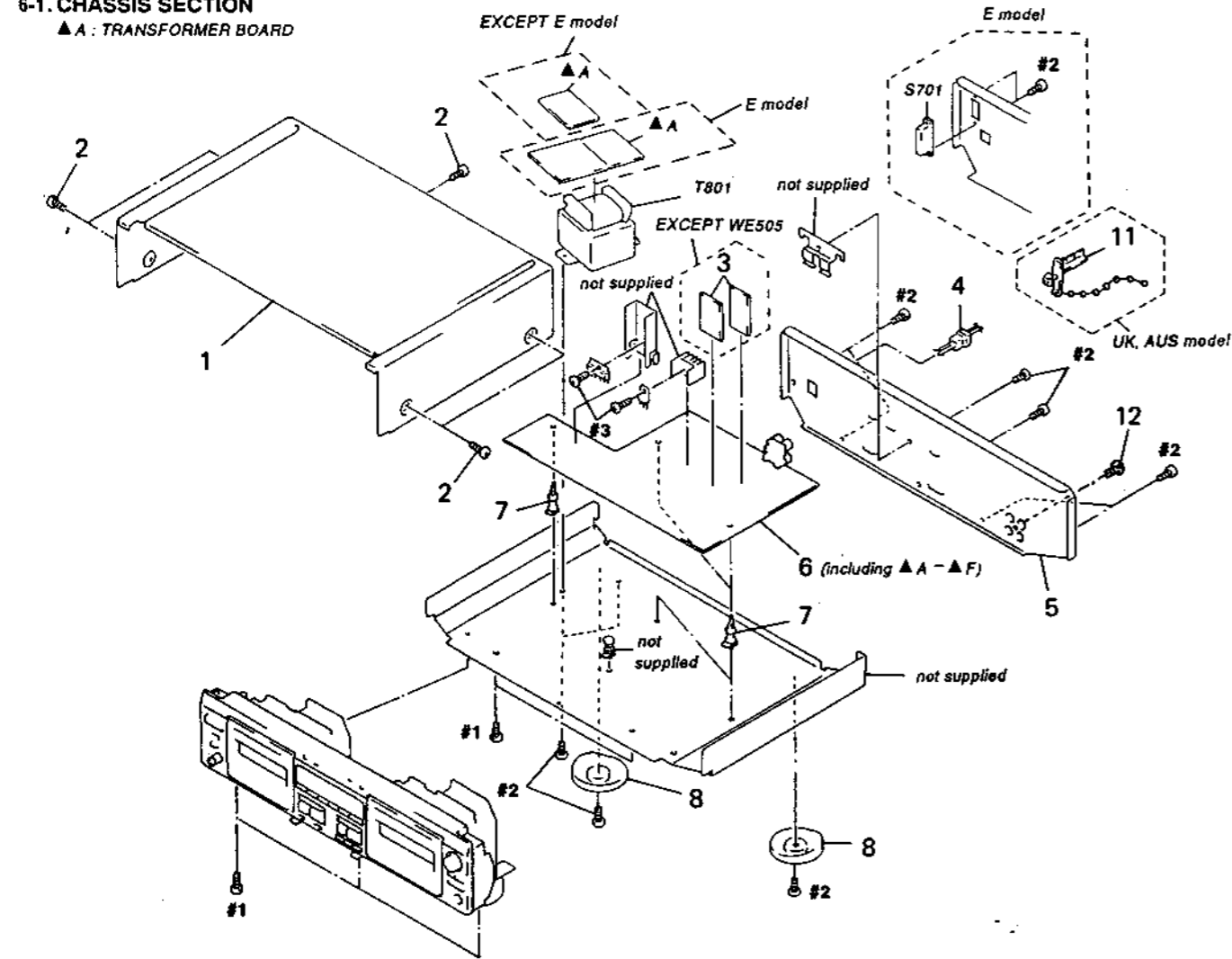

Ref. No.	Part No.	Description	Remark	Ref. No.	Part No.	Description	Remark
* 1	3-931-432-01	CASE (410726) (WA7ESA,WE605S,WR550Z)		* 6	A-2007-494-A	MAIN BOARD, COMPLETE (WE505)	
* 1	4-943-088-41	CASE (WE505,WE705S)		* 6	A-2007-495-A	MAIN BOARD, COMPLETE (WE705S)	
2	3-363-099-01	SCREW (CASE 3 TP2)(WE505,WE705S)		* 6	A-2007-513-A	MAIN BOARD, COMPLETE (WA7ESA)	
2	3-704-366-01	SCREW (CASE) (M3X8) (WA7ESA,WE605S,WR550Z)		* 6	A-2007-547-A	MAIN BOARD, COMPLETE (WR550Z)	
* 3	A-2007-481-A	DOLBY-S BOARD, COMPLETE (EXCEPT WE505)		* 6	A-2007-576-A	MAIN BOARD, COMPLETE (WE605S:MY,SP,CH)	
* 4	3-703-244-11	BUSHING (2104), CORD (AEP,UK,G,AUS,MY,SP,CH)		* 7	3-346-265-31	HOLDER, PC BOARD	
4	3-703-571-11	BUSHING (S) (4516), CORD (US,CND,E,PA)		8	X-3371-435-1	FOOT ASSY (F50150S) (AEP,UK,G,E,AUS,MY,SP,CH)	
* 5	3-920-372-21	PANEL, BACK (WE505:UK)		8	X-3371-436-1	FOOT ASSY (F50145S) (US,CND,PA)	
* 5	3-931-244-01	PANEL, BACK (WE605S:US,PA)		$\Delta$ 9	1-551-188-99	CORD, POWER (E)	
* 5	3-931-244-11	PANEL, BACK (WE605S:CND)		$\Delta$ 9	1-558-945-21	CORD, POWER (POLAR SPT-1) (US,CND,PA)	
				$\Delta$ 9	1-575-651-21	CORD, POWER (AEP,G,MY,SP,CH)	
* 5	3-931-244-21	PANEL, BACK (WE605S:E)		$\Delta$ 9	1-696-586-11	CORD, POWER (UK)	
* 5	3-931-244-31	PANEL, BACK (WE605S:AUS)		$\Delta$ 9	1-696-845-11	CORD, POWER (AUS)	
* 5	3-931-244-41	PANEL, BACK (WE605S:MY,SP,CH)		$\Delta$ 10	1-569-007-11	ADAPTER, CONVERSION 2P (E)	
* 5	3-931-245-01	PANEL, BACK (WE505:AEP,G)		$\Delta$ 10	1-569-008-21	ADAPTER, CONVERSION 2P (CH)	
* 5	3-931-245-21	PANEL, BACK (WR550Z)		11	4-956-370-12	BAND, PLUG FIXED (UK,AUS)	
* 5	3-931-246-01	PANEL, BACK (WE705S)		12	3-704-515-01	SCREW (BV,RING) (WE505,WE705S)	
* 5	3-932-543-01	PANEL, BACK (WA7ESA:US)		$\Delta$ S701	1-692-155-11	SELECTOR, POWER-VOLTAGE (VOLTAGE SELECTOR) (E)	
* 5	3-932-543-11	PANEL, BACK (WA7ESA:CND)		$\Delta$ T801	1-427-782-11	TRANSFORMER, POWER (US,CND,PA)	
* 6	A-2007-491-A	MAIN BOARD, COMPLETE (WE605S:US,CND,PA)		$\Delta$ T801	1-427-783-11	TRANSFORMER, POWER (AEP,UK,G,AUS,MY,SP,CH)	
* 6	A-2007-492-A	MAIN BOARD, COMPLETE (WE605S:E)		$\Delta$ T801	1-427-784-11	TRANSFORMER, POWER (E)	
* 6	A-2007-493-A	MAIN BOARD, COMPLETE (WE605S:AUS)					

### 6-2. FRONT PANEL SECTION

- ▲ B : DIRECTION BOARD
- ▲ C : POWER SWITCH BOARD (WE505, WE705S)
- ▲ D : VOL BOARD
- ▲ E : PANEL BOARD
- ▲ F : HEADPHONE BOARD

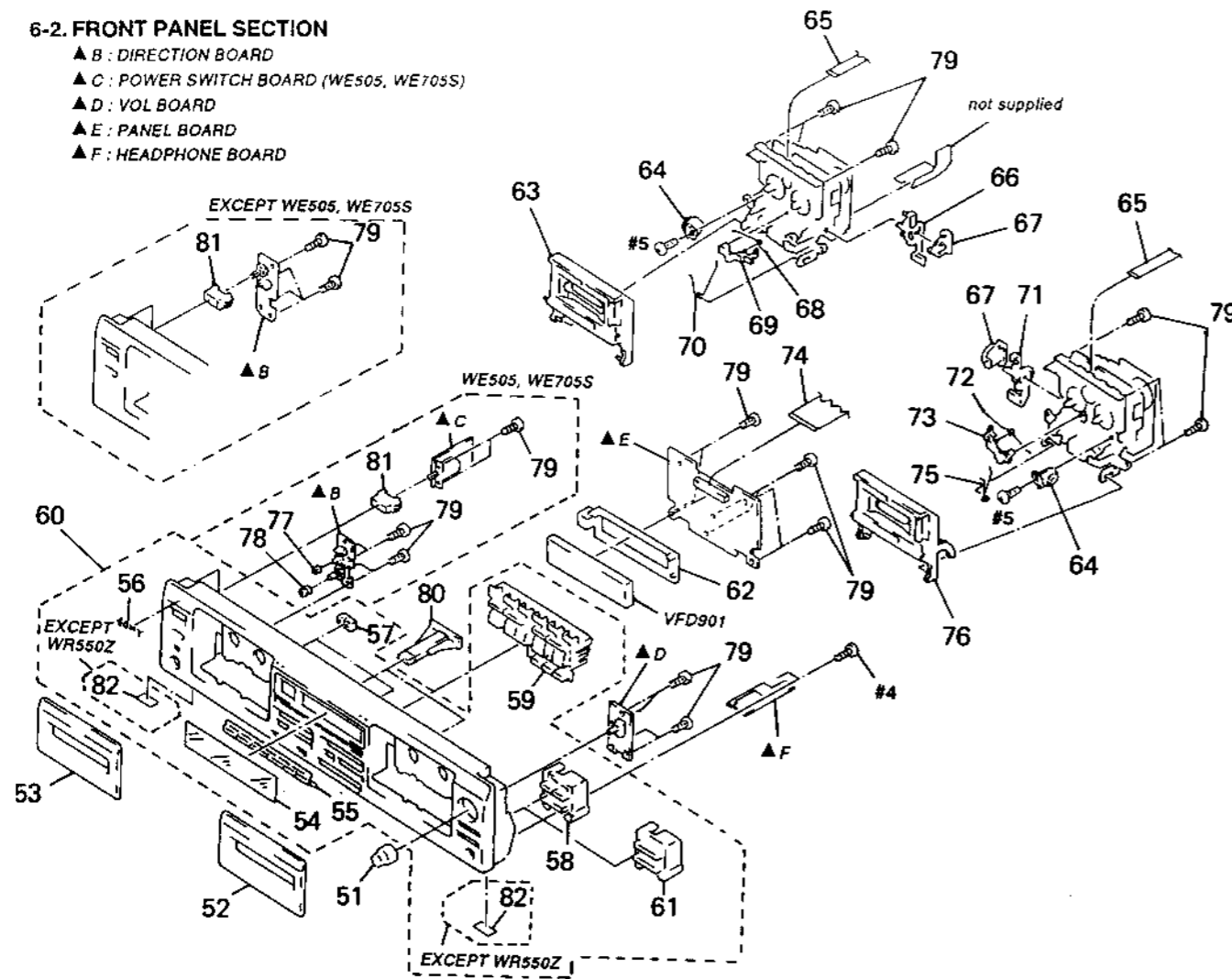

Ref. No.	Part No.	Description	Remark	Ref. No.	Part No.	Description	Remark
51	3-909-661-21	KNOB (REC) (WE505, WE705S)		64	3-354-963-01	DAMPER	
51	3-931-430-11	KNOB (REC) (WA7ESA, WE605S, WR550Z)		65	1-769-882-11	WIRE (FLAT TYPE) (7 CORE) (WE505, WE605S, WR550Z)	
52	X-3371-367-1	LID (HF) ASSY (B), CASSETTE (EXCEPT WA7ESA)		65	1-769-912-11	WIRE (FLAT TYPE) (9 CORE) (WA7ESA, WE705S)	
52	X-3371-572-1	LID (ES) ASSY (B), CASSETTE (WA7ESA)		* 66	3-354-953-01	LEVER (LOCK LEVER L)	
53	X-3371-366-1	LID (HF) ASSY (A), CASSETTE (EXCEPT WA7ESA)		67	3-354-957-01	JOINT (LOCK LEVER)	
53	X-3371-571-1	LID (ES) ASSY (A), CASSETTE (WA7ESA)		68	3-354-961-01	SPRING (EJ SAFTY SPRING L)	
54	3-931-248-01	WINDOW (M) (EXCEPT WA7ESA:CND)		69	3-354-955-01	LEVER (EJ SAFTY LEVER L)	
54	3-931-248-31	WINDOW (M) (WA7ESA:CND)		70	4-959-231-11	SPRING (L), TORSION	
55	3-931-237-01	BUTTON (RMS-6)		* 71	3-354-954-01	LEVER (LOCK LEVER R)	
56	4-963-404-21	EMBLEM (5-A), SONY		72	3-354-962-01	SPRING (EJ SAFTY SPRING R)	
57	3-931-243-01	BUTTON (COUNTER)		73	3-354-956-01	LEVER (EJ SAFTY LEVER R)	
58	X-3371-370-1	BUTTON (SYNCHRO) ASSY (WE705S, WE605S)		74	1-769-598-11	WIRE (FLAT TYPE) (41 CORE)	
59	3-931-239-01	BUTTON (SR)		75	4-959-232-11	SPRING (R), TORSION	
60	X-3371-355-1	PANEL (HF) ASSY, FRONT (WE605S:US,CND,PA)		76	X-4945-946-1	HOLDER (R) ASSY, CASSETTE	
60	X-3371-356-1	PANEL (HF) ASSY, FRONT (WE605S:E,AUS,MY,SP,CH)		77	3-380-952-21	BUTTON (5X5)	
60	X-3371-357-1	PANEL ASSY, FRONT (WR550Z)		78	3-931-378-01	KNOB (F10) (WE505, WE705S)	
60	X-3371-358-1	PANEL ASSY, FRONT (WE505)		79	4-951-620-01	SCREW (2.6X8), +BVTP	
60	X-3371-361-1	PANEL ASSY, FRONT (WE705S)		80	3-377-328-11	BUTTON (EJECT) (WE505, WE705S)	
60	X-3371-567-1	PANEL (ES) ASSY, FRONT (WA7ESA:US)		80	3-931-427-11	BUTTON (EJ) (WA7ESA, WE605S, WR550Z)	
60	X-3371-568-1	PANEL (ES) ASSY, FRONT (WA7ESA:CND)		81	3-354-932-01	BUTTON (POWER) (WE505, WE705S)	
61	3-931-242-01	BUTTON (ARL) (WA7ESA, WE505, WR550Z)		81	3-931-429-01	BUTTON (POWER) (WE605S, WR550Z)	
* 62	3-377-337-11	HOLDER (FL)		81	4-922-921-31	BUTTON (POWER) (WA7ESA)	
63	X-4945-947-1	HOLDER (L) ASSY, CASSETTE		82	4-977-358-01	CUSHION (8X12.5) (EXCEPT WR550Z)	
				VFD901	1-517-263-11	INDICATOR TUBE, FLUORESCENT	

### 6-3. MECHANISM SECTION 1

- DECK-A (TC-WE605S/WR550Z : TCM-190RA12CL)
- TC-WE505 : TCM-190RA14CL
- TC-WA7ESA : TCM-190RA17CL
- TC-WE705S : TCM-190RA18C
- DECK-B (TC-WA7ESA/WE705S : TCM-190RB11C)
- TC-WE505/WE605S/WR550Z : TCM-190RB12CL

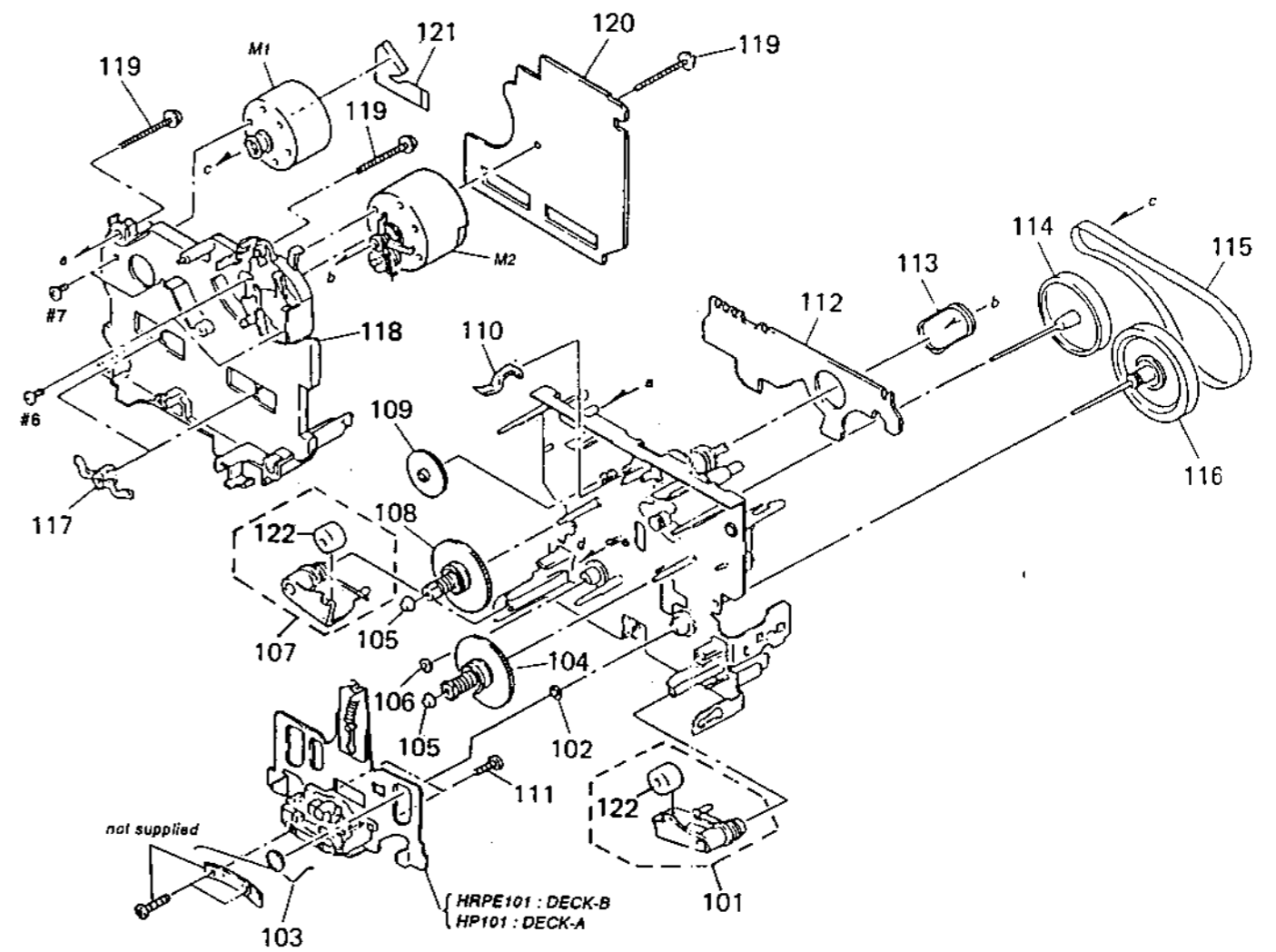

Ref. No.	Part No.	Description	Remark	Ref. No.	Part No.	Description	Remark
101	X-3366-047-1	LEVER (PINCH F) ASSY		116	X-3367-629-1	FLYWHEEL (FWD) ASSY	
102	3-356-713-01	WASHER		117	3-575-321-00	RETAINER, THRUST, CAPSTAN	
103	3-907-362-01	SPRING, TORSION		118	3-359-436-11	BASE (THRUST RETAINER), FITTING	
104	X-3366-970-1	TABLE ASSY, REEL (WE505, WE605S, WR550Z)		119	3-359-414-01	SCREW (+PTPWH 2X23)	
104	X-3366-971-1	TABLE ASSY, REEL (WA7ESA, WE705S)		* 120	A-2007-040-A	AUDIO BOARD, COMPLETE (DECK B)	
105	3-362-308-01	CAP (REEL)		* 120	A-2007-266-A	AUDIO BOARD, COMPLETE (DECK A) (WE605S, WR550Z)	
106	3-356-714-01	WASHER		* 120	A-2007-339-A	AUDIO BOARD, COMPLETE (DECK A) (WE505)	
107	X-3366-048-1	LEVER (PINCH R) ASSY		* 120	A-2007-479-A	AUDIO BOARD, COMPLETE (DECK A) (WA7ESA)	
108	X-3366-971-1	TABLE ASSY (B), REEL		* 120	A-2007-480-A	AUDIO BOARD, COMPLETE (DECK A) (WE705S)	
109	3-359-424-01	GEAR (REV GEAR)		121	1-638-983-11	MOTOR FLEXIBLE BOARD	
110	3-359-430-01	SPRING (CASSETTE RETAINER), LEAF		122	3-355-808-02	PINCH ROLLER	
111	3-388-848-01	SCREW (P2X6) (B TIGHT)		HP101	A-2004-526-A	DECK ASSY, HEAD (PLAYBACK) (WE505, WE605S, WR550Z)	
* 112	1-634-841-14	LEAF SW BOARD (DECK A) (WA7ESA, WE705S)		HP101	A-2004-548-A	DECK ASSY, HEAD (PLAYBACK) (WA7ESA, WE705S)	
* 112	1-638-020-11	LEAF SW BOARD (DECK A) (WE505, WE605S, WR550Z)		HRPE101A-2004-527-A	DECK ASSY, HEAD (RECORD / PLAYBACK / ERASE)		
* 112	1-634-841-14	LEAF SW BOARD (DECK B) (WA7ESA, WE705S)		M1	X-3365-377-2	MOTOR ASSY (CAPSTAN)	
* 112	1-638-020-11	LEAF SW BOARD (DECK B) (WE505, WE605S, WR550Z)		M2	X-3365-501-2	MOTOR ASSY (REEL)	
113	3-359-466-01	BELT (FR), SQUARE					
114	X-3367-630-1	FLYWHEEL (REV) ASSY					
115	3-359-417-01	BELT (FLAT), CAPSTAN					

6-4. MECHANISM SECTION 2

DECK-A (TC-WE605S/WR550Z : TCM-190RA12CL  
 TC-WE505 : TCM-190RA14CL  
 TC-WA7ESA : TCM-190RA17CL  
 TC-WE705S : TCM-190RA18C )  
 DECK-B (TC-WA7ESA/WE705S : TCM-190RB11C )  
 TC-WE505/WE605S/WR550Z : TCM-190RB12CL )

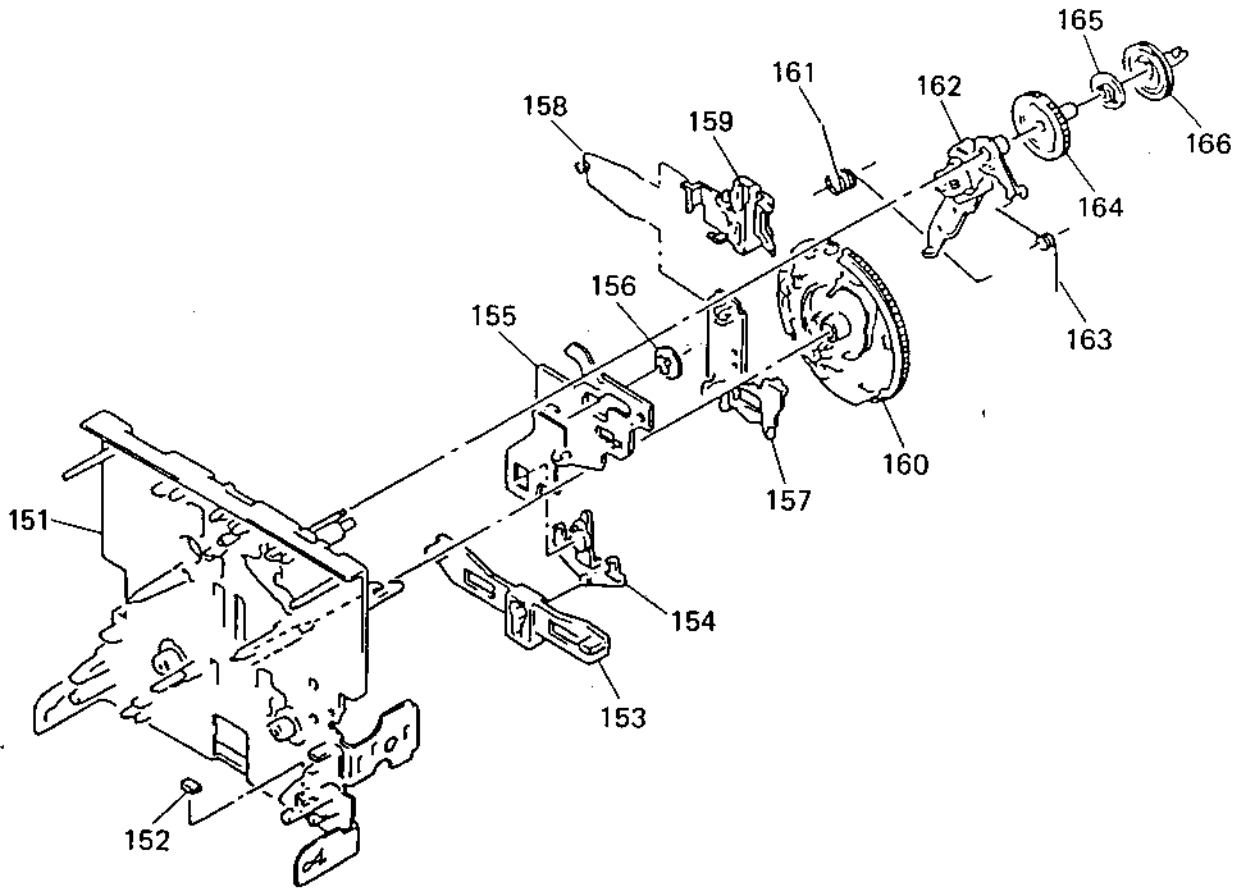

Ref. No.	Part No.	Description	Remark	Ref. No.	Part No.	Description	Remark
151	X-3359-415-1	CHASSIS ASSY MECHANICAL		159	3-359-429-01	SLIDER (BRAKE PLATE)	
152	3-359-469-01	SPACER		* 160	3-936-483-01	GEAR (CAM GEAR)	
153	3-359-425-01	SLIDER (REVERSE SLIDER)		161	3-359-456-01	SPRING (TRIGGER SPRING), TORSION	
154	3-359-426-01	LEVER (REVERSE LEVER)		162	X-3366-569-1	ARM ASSY, FR	
* 155	3-359-415-01	SLIDER (TRIGGER SLIDER)		163	3-924-185-11	SPRING (FR ARM), TORSION	
156	3-359-448-01	GEAR (TRIGGER)		164	3-359-419-11	GEAR (FR GEAR)	
157	3-359-427-01	SLIDER (LEVERSE SLIDER)		165	3-359-421-01	CLUTCH (REEL DISK)	
158	3-359-454-01	SPRING, TORSION		166	3-359-418-01	PULLEY (FR PULLEY)	

SECTION 7  
ELECTRICAL PARTS LIST

AUDIO (DECK A)

NOTE :

- Due to standardization, replacements in the parts list may be different from the parts specified in the diagrams or the components used on the set.
- -XX, -X mean standardized parts, so they may have some difference from the original one.
- RESISTORS  
All resistors are in ohms  
METAL : Metal-film resistor  
METAL OXIDE : Metal oxide-film resistor  
F : nonflammable
- Items marked " \* " are not stocked since they are seldom required for routine service. Some delay should be anticipated when ordering these items.

• SEMICONDUCTORS

In each case, u :  $\mu$ , for example :  
uA :  $\mu$  A, uPA :  $\mu$  PA  
uPB :  $\mu$  PB, uPC :  $\mu$  PC  
uPD :  $\mu$  PD

• CAPACITORS

uF :  $\mu$  F

• COILS

uH :  $\mu$  H

• Abbreviation

CND : Canadian G : German  
AUS : Australian MY : Malaysia  
SP : Singapore CH : Chinese  
PA : Panama

The components identified by mark  $\Delta$  or dotted line with mark  $\Delta$  are critical for safety.  
Replace only with part number specified.

Les composants identifiés par une marque  $\Delta$  sont critiques pour la sécurité.  
Ne les remplacer que par une pièce portant le numéro spécifié.

When indicating parts by reference number, please include the board.

Ref. No.	Part No.	Description	Remark
*	A-2007-266-A	AUDIO BOARD, COMPLETE (DECK A) (WE605S, WR550Z)	
*	A-2007-339-A	AUDIO BOARD, COMPLETE (DECK A) (WE505)	
*	A-2007-479-A	AUDIO BOARD, COMPLETE (DECK A) (WA7ESA)	
*	A-2007-480-A	AUDIO BOARD, COMPLETE (DECK A) (WE705S)	
< CAPACITOR >			
C11	1-163-131-00	CERAMIC CHIP	390PF 5% 50V
C12	1-136-157-00	FILM	0.022uF 5% 50V
C13	1-124-234-00	ELECT	22uF 20% 16V
C18	1-163-251-11	CERAMIC CHIP	100PF 5% 50V
C21	1-163-131-00	CERAMIC CHIP	390PF 5% 50V
C22	1-136-157-00	FILM	0.022uF 5% 50V
C23	1-124-234-00	ELECT	22uF 20% 16V
C28	1-163-251-11	CERAMIC CHIP	100PF 5% 50V
C31	1-124-234-00	ELECT	22uF 20% 16V
C32	1-124-234-00	ELECT	22uF 20% 16V
C72	1-109-889-11	ELECT	1uF 20% 50V
< CONNECTOR >			
* CNJ31	1-580-782-11	CONNECTOR, BOARD TO BOARD	
CNJ72	1-764-902-11	CONNECTOR, FFC/FPC 4P	
* CNP30	1-564-718-11	PIN, CONNECTOR (SMALL TYPE) 2P (WE505, WE705S)	
* CNP32	1-580-772-11	PIN, CONNECTOR (PC BOARD) 4P	
* CNP71	1-564-719-11	PIN, CONNECTOR (SMALL TYPE) 3P	
< IC >			
IC31	8-759-106-02	IC uPC4570G2	
< JUMPER RESISTOR >			
JW1	1-216-295-00	METAL CHIP	0 5% 1/10W
JW51	1-216-296-00	METAL CHIP	0 5% 1/8W
JW52	1-216-296-00	METAL CHIP	0 5% 1/8W
JW53	1-216-296-00	METAL CHIP	0 5% 1/8W
JW54	1-216-296-00	METAL CHIP	0 5% 1/8W

Ref. No.	Part No.	Description	Remark
JW101	1-216-295-00	METAL CHIP	0 5% 1/10W (WE505, WE705S)
< TRANSISTOR >			
Q71	8-729-216-22	TRANSISTOR	2SA1162-G
< RESISTOR >			
R11	1-216-099-00	METAL CHIP	120K 5% 1/10W
R12	1-216-025-91	METAL GLAZE	100 5% 1/10W
R13	1-216-100-00	METAL GLAZE	130K 5% 1/10W
R14	1-216-069-00	METAL CHIP	6.8K 5% 1/10W (WA7ESA, WE705S)
R14	1-216-068-00	METAL CHIP	6.2K 5% 1/10W (WE505, WE605S, WR550Z)
R21	1-216-099-00	METAL CHIP	120K 5% 1/10W
R22	1-216-025-91	METAL GLAZE	100 5% 1/10W
R23	1-216-100-00	METAL GLAZE	130K 5% 1/10W
R24	1-216-069-00	METAL CHIP	6.8K 5% 1/10W (WA7ESA, WE705S)
R24	1-216-068-00	METAL CHIP	6.2K 5% 1/10W (WE505, WE605S, WR550Z)
R31	1-216-033-00	METAL CHIP	220 5% 1/10W
R32	1-216-033-00	METAL CHIP	220 5% 1/10W
R71	1-216-082-00	METAL GLAZE	24K 5% 1/10W
R72	1-216-081-00	METAL CHIP	22K 5% 1/10W
R73	1-216-089-91	METAL GLAZE	47K 5% 1/10W
R74	1-216-089-91	METAL GLAZE	47K 5% 1/10W
< VARIABLE RESISTOR >			
RV11	1-241-761-11	RES, ADJ, CARBON 1K (PB LEVEL L)	
RV21	1-241-761-11	RES, ADJ, CARBON 1K (PB LEVEL R)	
RV71	1-241-630-11	RES, ADJ, CARBON 10K (TAPE SPEED(NORMAL))	
RV72	1-241-630-11	RES, ADJ, CARBON 10K (TAPE SPEED(HIGH))	

Ref. No.	Part No.	Description	Remark
*	A-2007-040-A	AUDIO BOARD, COMPLETE (DECK B)	
< CAPACITOR >			
C11	1-163-131-00	CERAMIC CHIP	390PF 5% 50V
C12	1-136-157-00	FILM	0.022uF 5% 50V
C13	1-124-234-00	ELECT	22uF 20% 16V
C18	1-163-251-11	CERAMIC CHIP	100PF 5% 50V
C21	1-163-131-00	CERAMIC CHIP	390PF 5% 50V
C22	1-136-157-00	FILM	0.022uF 5% 50V
C23	1-124-234-00	ELECT	22uF 20% 16V
C28	1-163-251-11	CERAMIC CHIP	100PF 5% 50V
C31	1-124-234-00	ELECT	22uF 20% 16V
C32	1-124-234-00	ELECT	22uF 20% 16V
C33	1-124-234-00	ELECT	22uF 20% 16V
C51	1-164-161-11	CERAMIC CHIP	0.0022uF 10% 100V
C52	1-164-161-11	CERAMIC CHIP	0.0022uF 10% 100V
C53	1-163-019-00	CERAMIC CHIP	0.0068uF 10% 50V
C54	1-136-601-11	FILM	0.01uF 5% 630V
C56	1-164-505-11	CERAMIC CHIP	2.2uF 16V
C57	1-164-346-11	CERAMIC CHIP	1uF 16V
C71	1-164-346-11	CERAMIC CHIP	1uF 16V
C80	1-124-234-00	ELECT	22uF 20% 16V
C81	1-164-232-11	CERAMIC CHIP	0.01uF 50V
C82	1-136-157-00	FILM	0.022uF 5% 50V
C83	1-164-004-11	CERAMIC CHIP	0.1uF 10% 25V
C84	1-136-478-11	FILM	470PF 5% 630V
C85	1-136-433-11	FILM	100PF 5% 630V
C86	1-163-143-00	CERAMIC CHIP	0.0012uF 5% 50V
C87	1-136-273-91	FILM	75PF 5% 630V
C88	1-163-003-11	CERAMIC CHIP	330PF 10% 50V
C89	1-124-234-00	ELECT	22uF 20% 16V
C90	1-107-584-11	CERAMIC	4PF 0.25PF500V
C91	1-164-232-11	CERAMIC CHIP	0.01uF 50V
C92	1-136-157-00	FILM	0.022uF 5% 50V
C93	1-164-004-11	CERAMIC CHIP	0.1uF 10% 25V
C94	1-136-478-11	FILM	470PF 5% 630V
C95	1-136-433-11	FILM	100PF 5% 630V
C96	1-163-143-00	CERAMIC CHIP	0.0012uF 5% 50V
C97	1-136-273-91	FILM	75PF 5% 630V
C98	1-163-003-11	CERAMIC CHIP	330PF 10% 50V
C99	1-164-005-11	CERAMIC CHIP	0.47uF 25V
< CONNECTOR >			
* CNP31	1-580-782-11	CONNECTOR, BOARD TO BOARD	
* CNP32	1-580-781-11	PIN, CONNECTOR (PC BOARD) 7P	
* CNP33	1-580-782-11	CONNECTOR, BOARD TO BOARD	
* CNP71	1-564-719-11	PIN, CONNECTOR (SMALL TYPE) 3P	
CNP72	1-764-902-11	CONNECTOR, FFC/FPC 4P	
* CNP75	1-564-718-11	PIN, CONNECTOR (SMALL TYPE) 2P	

AUDIO (DECK B)

Ref. No.	Part No.	Description	Remark
< DIODE >			
D31	8-719-404-46	DIODE	MA110
< IC >			
IC31	8-759-106-02	IC uPC4570G2	
IC81	8-759-106-56	IC uPC1297CA	
< COIL >			
L81	1-410-780-11	INDUCTOR	27mH
L91	1-410-780-11	INDUCTOR	27mH
< TRANSISTOR >			
Q51	8-729-822-05	TRANSISTOR	2SD1622-ST-TD
Q52	8-729-822-05	TRANSISTOR	2SD1622-ST-TD
Q53	8-729-822-05	TRANSISTOR	2SD1622-ST-TD
Q71	8-729-216-22	TRANSISTOR	2SA1162-G
< RESISTOR >			
R11	1-216-099-00	METAL CHIP	120K 5% 1/10W
R12	1-216-025-91	METAL GLAZE	100 5% 1/10W
R13	1-216-100-00	METAL GLAZE	130K 5% 1/10W
R14	1-216-068-00	METAL CHIP	6.2K 5% 1/10W
R21	1-216-099-00	METAL CHIP	120K 5% 1/10W
R22	1-216-025-91	METAL GLAZE	100 5% 1/10W
R23	1-216-100-00	METAL GLAZE	130K 5% 1/10W
R24	1-216-068-00	METAL CHIP	6.2K 5% 1/10W
R31	1-216-033-00	METAL CHIP	220 5% 1/10W
R32	1-216-033-00	METAL CHIP	220 5% 1/10W
R33	1-216-065-00	METAL CHIP	4.7K 5% 1/10W
R51	1-216-097-91	METAL GLAZE	100K 5% 1/10W
R52	1-216-097-91	METAL GLAZE	100K 5% 1/10W
R53	1-216-073-00	METAL CHIP	10K 5% 1/10W
R54	1-216-309-00	METAL CHIP	5.6 5% 1/10W
R55	1-216-309-00	METAL CHIP	5.6 5% 1/10W
R57	1-216-298-00	METAL CHIP	2.2 5% 1/10W
R71	1-216-082-00	METAL GLAZE	24K 5% 1/10W
R72	1-216-081-00	METAL CHIP	22K 5% 1/10W
R73	1-216-089-91	METAL GLAZE	47K 5% 1/10W
R74	1-216-089-91	METAL GLAZE	47K 5% 1/10W
R81	1-216-073-00	METAL CHIP	10K 5% 1/10W
R82	1-216-085-00	METAL CHIP	33K 5% 1/10W
R83	1-216-001-00	METAL CHIP	10 5% 1/10W
R84	1-216-101-00	METAL CHIP	150K 5% 1/10W
R85	1-216-075-00	METAL CHIP	12K 5% 1/10W
R91	1-216-073-00	METAL CHIP	10K 5% 1/10W
R92	1-216-085-00	METAL CHIP	33K 5% 1/10W
R93	1-216-001-00	METAL CHIP	10 5% 1/10W
R94	1-216-101-00	METAL CHIP	150K 5% 1/10W
R95	1-216-075-00	METAL CHIP	12K 5% 1/10W

**MAIN DIRECTION HEADPHONE PANEL**  
**POWER SWITCH TRANSFORMER VOL**

Ref. No.	Part No.	Description	Remark
* CN807	1-568-954-11	PIN, CONNECTOR 5P	
		< CONNECTOR >	
CNP802	1-770-247-11	SOCKET, CONNECTOR 41P	
		< DIODE >	
D101	8-719-933-33	DIODE HZS6A1L	
D201	8-719-933-33	DIODE HZS6A1L	
D521	8-719-987-63	DIODE 1N4148M	
D522	8-719-987-63	DIODE 1N4148M	
D601	8-719-987-63	DIODE 1N4148M (WA7ESA,WE505,WE705S)	
D602	8-719-987-63	DIODE 1N4148M (WA7ESA,WE505,WE705S)	
D701	8-719-024-99	DIODE 11ES2-NTA2B	
D702	8-719-024-99	DIODE 11ES2-NTA2B	
D703	8-719-024-99	DIODE 11ES2-NTA2B	
D704	8-719-024-99	DIODE 11ES2-NTA2B	
D705	8-719-987-63	DIODE 1N4148M	
D706	8-719-987-63	DIODE 1N4148M	
D707	8-719-024-99	DIODE 11ES2-NTA2B	
D708	8-719-987-63	DIODE 1N4148M	
D709	8-719-933-33	DIODE HZS6A1L	
D710	8-719-933-33	DIODE HZS6A1L	
D711	8-719-933-33	DIODE HZS6A1L	
D712	8-719-933-38	DIODE HZS6B3L	
D713	8-719-987-63	DIODE 1N4148M	
D714	8-719-987-63	DIODE 1N4148M	
D715	8-719-987-63	DIODE 1N4148M	
D716	8-719-000-78	DIODE UZL-7L2	
D801	8-719-987-63	DIODE 1N4148M	
D802	8-719-987-63	DIODE 1N4148M	
D803	8-719-987-63	DIODE 1N4148M	
D804	8-719-987-63	DIODE 1N4148M	
D805	8-719-987-63	DIODE 1N4148M (WE605S,WE705S)	
D901	8-719-313-43	LED SEL6210S-TH10 (AUTO REC LEVEL)	
D902	8-719-313-43	LED SEL6210S-TH10 (SYNCHRO)	(WE605S,WE705S)
		< IC >	
IC501	8-752-075-27	IC CXA1878Q	
IC502	8-759-634-51	IC M5218AP	
IC503	8-759-634-51	IC M5218AP	
IC601	8-759-822-38	IC LA6510	
IC701	8-759-634-51	IC M5218AP	
IC801	8-752-871-45	IC CXP82224-043Q	
IC802	8-759-165-82	IC PST600E-T	
IC802	8-759-520-90	IC PST572E	
IC804	8-759-916-14	IC SN74HC04AN	
IC805	8-759-000-48	IC MC14052BCP	
IC901	8-741-810-59	IC SBX1810-59	
		< JACK >	
J501	1-770-614-11	JACK, PIN 4P (LINE IN/OUT)	

Ref. No.	Part No.	Description	Remark
J502	1-568-519-41	JACK, LARGE TYPE (PHONES)	
* J801	1-764-188-11	JACK (SMALL TYPE) (DIA. 3.5) (CONTROL A)	(WE605S,WE705S)
* J802	1-764-188-11	JACK (SMALL TYPE) (DIA. 3.5) (CONTROL A)	(WE605S,WE705S)
		< FILTER >	
LPF101	1-233-271-11	FILTER, LOW PASS	
LPF201	1-233-271-11	FILTER, LOW PASS	
		< TRANSISTOR >	
Q101	8-729-900-74	TRANSISTOR DTC143TS	
Q102	8-729-922-37	TRANSISTOR 2SD2144S	
Q201	8-729-900-74	TRANSISTOR DTC143TS	
Q202	8-729-922-37	TRANSISTOR 2SD2144S	
Q501	8-729-119-76	TRANSISTOR 2SA1175-HFE	
Q502	8-729-620-05	TRANSISTOR 2SC2603-EF	
Q503	8-729-620-05	TRANSISTOR 2SC2603-EF	
Q601	8-729-900-80	TRANSISTOR DTC114ES	
Q602	8-729-801-93	TRANSISTOR 2SD1387	
Q603	8-729-801-93	TRANSISTOR 2SD1387	
Q604	8-729-900-80	TRANSISTOR DTC114ES (WE505,WE705S)	
Q605	8-729-119-76	TRANSISTOR 2SA1175-HFE (WE505, WE705S)	
Q606	8-729-900-80	TRANSISTOR DTC114ES	
Q701	8-729-141-83	TRANSISTOR 2SB1094-LK	
Q702	8-729-209-15	TRANSISTOR 2SD2012	
Q703	8-729-141-83	TRANSISTOR 2SB1094-LK	
Q704	8-729-620-05	TRANSISTOR 2SC2603-EF	
Q705	8-729-900-80	TRANSISTOR DTC114ES (WA7ESA,WE605S, WR550Z)	
Q706	8-729-900-80	TRANSISTOR DTC114ES (WA7ESA,WE605S, WR550Z)	
Q707	8-729-119-76	TRANSISTOR 2SA1175-HFE	
Q708	8-729-140-04	TRANSISTOR 2SB1116A-L	
Q709	8-729-224-62	TRANSISTOR 2SK246-GR (WA7ESA)	
Q801	8-729-900-89	TRANSISTOR DTC144ES	
Q802	8-729-900-74	TRANSISTOR DTC143TS (WA7ESA,WE605S, WR550Z)	
Q803	8-729-620-05	TRANSISTOR 2SC2603-EF (WE605S, WE705S)	
Q804	8-729-119-76	TRANSISTOR 2SA1175-HFE	
Q805	8-729-900-61	TRANSISTOR DTA114ES	
Q806	8-729-900-80	TRANSISTOR DTC114ES	
Q807	8-729-900-65	TRANSISTOR DTA144ES (WA7ESA,WE505, WE705S)	
		< RESISTOR >	
R101	1-249-429-11	CARBON 10K 5% 1/4W	
R102	1-247-887-00	CARBON 220K 5% 1/4W	
R103	1-249-441-11	CARBON 100K 5% 1/4W	
R104	1-249-420-11	CARBON 1.8K 5% 1/4W	
R105	1-249-423-11	CARBON 3.3K 5% 1/4W	

**MAIN DIRECTION HEADPHONE PANEL**  
**POWER SWITCH TRANSFORMER VOL**

Ref. No.	Part No.	Description	Remark
R106	1-247-842-11	CARBON 3K 5% 1/4W	
R107	1-249-417-11	CARBON 1K 5% 1/4W	
R108	1-249-424-11	CARBON 3.9K 5% 1/4W	
R109	1-249-429-11	CARBON 10K 5% 1/4W	
R110	1-249-425-11	CARBON 4.7K 5% 1/4W	
R111	1-249-421-11	CARBON 2.2K 5% 1/4W	
R112	1-249-430-11	CARBON 12K 5% 1/4W	
R113	1-249-417-11	CARBON 1K 5% 1/4W	
R114	1-249-421-11	CARBON 2.2K 5% 1/4W	
R115	1-249-433-11	CARBON 22K 5% 1/4W	
R116	1-249-423-11	CARBON 3.3K 5% 1/4W	
R117	1-249-429-11	CARBON 10K 5% 1/4W	
R118	1-249-409-11	CARBON 220 5% 1/4W	
R119	1-249-417-11	CARBON 1K 5% 1/4W	
R120	1-249-437-11	CARBON 47K 5% 1/4W	
R121	1-249-437-11	CARBON 47K 5% 1/4W	
R201	1-249-429-11	CARBON 10K 5% 1/4W	
R202	1-247-887-00	CARBON 220K 5% 1/4W	
R203	1-249-441-11	CARBON 100K 5% 1/4W	
R204	1-249-420-11	CARBON 1.8K 5% 1/4W	
R205	1-249-423-11	CARBON 3.3K 5% 1/4W	
R206	1-247-842-11	CARBON 3K 5% 1/4W	
R207	1-249-417-11	CARBON 1K 5% 1/4W	
R208	1-249-424-11	CARBON 3.9K 5% 1/4W	
R209	1-249-429-11	CARBON 10K 5% 1/4W	
R210	1-249-425-11	CARBON 4.7K 5% 1/4W	
R211	1-249-421-11	CARBON 2.2K 5% 1/4W	
R212	1-249-430-11	CARBON 12K 5% 1/4W	
R213	1-249-417-11	CARBON 1K 5% 1/4W	
R214	1-249-421-11	CARBON 2.2K 5% 1/4W	
R215	1-249-433-11	CARBON 22K 5% 1/4W	
R216	1-249-423-11	CARBON 3.3K 5% 1/4W	(EXCEPT WE505)
R217	1-249-429-11	CARBON 10K 5% 1/4W	
R218	1-249-409-11	CARBON 220 5% 1/4W	
R219	1-249-417-11	CARBON 1K 5% 1/4W	
R220	1-249-437-11	CARBON 47K 5% 1/4W	
R221	1-249-437-11	CARBON 47K 5% 1/4W	
R501	1-215-455-00	METAL 27K 1% 1/4W	
R502	1-215-452-00	METAL 20K 1% 1/4W	
R503	1-249-417-11	CARBON 1K 5% 1/4W	
R504	1-249-428-11	CARBON 8.2K 5% 1/4W	
R505	1-247-903-00	CARBON 1M 5% 1/4W	
R507	1-249-429-11	CARBON 10K 5% 1/4W	
R508	1-249-413-11	CARBON 470 5% 1/4W	
R509	1-249-417-11	CARBON 1K 5% 1/4W	
R510	1-249-437-11	CARBON 47K 5% 1/4W	
R511	1-249-429-11	CARBON 10K 5% 1/4W	
R512	1-249-413-11	CARBON 470 5% 1/4W	
R521	1-249-433-11	CARBON 22K 5% 1/4W	
R522	1-249-426-11	CARBON 5.6K 5% 1/4W	
R523	1-249-436-11	CARBON 39K 5% 1/4W	

Ref. No.	Part No.	Description	Remark
R524	1-249-425-11	CARBON 4.7K 5% 1/4W	
R525	1-249-425-11	CARBON 4.7K 5% 1/4W	
R526	1-249-441-11	CARBON 100K 5% 1/4W	
R527	1-249-441-11	CARBON 100K 5% 1/4W	
R528	1-247-852-11	CARBON 7.5K 5% 1/4W	
R531	1-249-437-11	CARBON 47K 5% 1/4W	
R532	1-249-437-11	CARBON 47K 5% 1/4W	
R533	1-249-437-11	CARBON 47K 5% 1/4W	
R601	1-247-807-31	CARBON 100 5% 1/4W	
R602	1-247-807-31	CARBON 100 5% 1/4W	
R603	1-249-433-11	CARBON 22K 5% 1/4W	
R604	1-249-433-11	CARBON 22K 5% 1/4W	
R605	1-249-430-11	CARBON 12K 5% 1/4W	
R606	1-249-430-11	CARBON 12K 5% 1/4W	
R607	1-247-858-11	CARBON 13K 5% 1/4W	
R608	1-247-858-11	CARBON 13K 5% 1/4W	
R609	1-247-858-11	CARBON 13K 5% 1/4W	
R610	1-247-858-11	CARBON 13K 5% 1/4W	
R613	1-249-422-11	CARBON 2.7K 5% 1/4W	
R614	1-249-422-11	CARBON 2.7K 5% 1/4W	
R615	1-247-854-11	CARBON 9.1K 5% 1/4W	
R616	1-247-854-11	CARBON 9.1K 5% 1/4W	
R617	1-249-429-11	CARBON 10K 5% 1/4W	
R618	1-249-421-11	CARBON 2.2K 5% 1/4W	
R619	1-249-429-11	CARBON 10K 5% 1/4W	
R620	1-249-421-11	CARBON 2.2K 5% 1/4W	
R621	1-249-435-11	CARBON 33K 5% 1/4W	(WE505,WE705S)
R622	1-247-848-11	CARBON 5.1K 5% 1/4W	(WE505,WE705S)
R623	1-249-437-11	CARBON 47K 5% 1/4W	(WE505,WE705S)
R624	1-249-437-11	CARBON 47K 5% 1/4W	(WE505,WE705S)
R701	1-249-414-11	CARBON 560 5% 1/4W	
R702	1-249-429-11	CARBON 10K 5% 1/4W	(WA7ESA,WE605S,WR550Z)
R703	1-249-419-11	CARBON 1.5K 5% 1/4W	
R704	1-249-425-11	CARBON 4.7K 5% 1/4W	
R705	1-249-427-11	CARBON 6.8K 5% 1/4W	
R706	1-249-419-11	CARBON 1.5K 5% 1/4W	
R707	1-249-429-11	CARBON 10K 5% 1/4W	
R708	1-249-419-11	CARBON 1.5K 5% 1/4W	
R709	1-249-425-11	CARBON 4.7K 5% 1/4W	
R710	1-249-417-11	CARBON 1K 5% 1/4W	
R711	1-249-427-11	CARBON 6.8K 5% 1/4W	
R712	1-249-427-11	CARBON 6.8K 5% 1/4W	
R713	1-249-417-11	CARBON 1K 5% 1/4W	
R714	1-249-429-11	CARBON 10K 5% 1/4W	
R715	1-249-422-11	CARBON 2.7K 5% 1/4W	
R716	1-249-433-11	CARBON 22K 5% 1/4W	
R717	1-249-429-11	CARBON 10K 5% 1/4W	

MAIN DIRECTION HEADPHONE PANEL

POWER SWITCH TRANSFORMER VOL

Ref. No.	Part No.	Description	Remark
R718	1-249-436-11	CARBON	39K 5% 1/4W
R719	1-249-430-11	CARBON	12K 5% 1/4W
△ R720	1-219-136-11	FUSIBLE	0.22 10% 1/4W F
R721	1-249-415-11	CARBON	680 5% 1/4W (WA7ESA)
R721	1-249-419-11	CARBON	1.5K 5% 1/4W (EXCEPT WA7ESA)
△ R722	1-219-137-11	FUSIBLE	0.33 10% 1/4W F
△ R723	1-219-137-11	FUSIBLE	0.33 10% 1/4W F
R724	1-249-412-11	CARBON	390 5% 1/4W (WA7ESA)
R805	1-249-429-11	CARBON	10K 5% 1/4W
R806	1-249-429-11	CARBON	10K 5% 1/4W
R807	1-249-429-11	CARBON	10K 5% 1/4W
R808	1-249-429-11	CARBON	10K 5% 1/4W
R809	1-249-441-11	CARBON	100K 5% 1/4W
R810	1-249-417-11	CARBON	1K 5% 1/4W
R811	1-249-433-11	CARBON	22K 5% 1/4W
R812	1-249-433-11	CARBON	22K 5% 1/4W
R813	1-247-807-31	CARBON	100 5% 1/4W
R814	1-249-433-11	CARBON	22K 5% 1/4W
R815	1-249-435-11	CARBON	33K 5% 1/4W
R816	1-249-441-11	CARBON	100K 5% 1/4W
R817	1-249-426-11	CARBON	5.6K 5% 1/4W
R818	1-249-422-11	CARBON	2.7K 5% 1/4W
R819	1-249-428-11	CARBON	8.2K 5% 1/4W
R820	1-249-428-11	CARBON	8.2K 5% 1/4W
R821	1-249-430-11	CARBON	12K 5% 1/4W
R822	1-247-852-11	CARBON	7.5K 5% 1/4W
R823	1-249-425-11	CARBON	4.7K 5% 1/4W
R824	1-249-425-11	CARBON	4.7K 5% 1/4W
R825	1-249-429-11	CARBON	10K 5% 1/4W
R826	1-249-429-11	CARBON	10K 5% 1/4W
R827	1-249-425-11	CARBON	4.7K 5% 1/4W (WE605S,WE705S)
R828	1-249-429-11	CARBON	10K 5% 1/4W (WE605S,WE705S)
R829	1-249-393-11	CARBON	10 5% 1/4W (WE605S,WE705S)
R830	1-249-421-11	CARBON	2.2K 5% 1/4W
R831	1-249-421-11	CARBON	2.2K 5% 1/4W
R832	1-249-434-11	CARBON	27K 5% 1/4W
R833	1-249-434-11	CARBON	27K 5% 1/4W (WA7ESA,WE705S)
R834	1-247-887-00	CARBON	220K 5% 1/4W
R835	1-247-887-00	CARBON	220K 5% 1/4W
R836	1-247-887-00	CARBON	220K 5% 1/4W
R837	1-247-887-00	CARBON	220K 5% 1/4W
R838	1-249-422-11	CARBON	2.7K 5% 1/4W
R839	1-249-422-11	CARBON	2.7K 5% 1/4W
R840	1-249-422-11	CARBON	2.7K 5% 1/4W
R841	1-249-429-11	CARBON	10K 5% 1/4W
R842	1-247-862-11	CARBON	20K 5% 1/4W

The components identified by mark △ or dotted line with mark △ are critical for safety. Replace only with part number specified.

Les composants identifiés par une marque △ sont critiques pour la sécurité. Ne les remplacer que par une pièce portant le numéro spécifié.

MAIN DIRECTION HEADPHONE PANEL POWER SWITCH

TRANSFORMER VOL LEAF SW (DECK A) LEAF SW (DECK B)

Ref. No.	Part No.	Description	Remark
R943	1-249-422-11	CARBON	2.7K 5% 1/4W
R944	1-249-424-11	CARBON	3.9K 5% 1/4W
R945	1-249-427-11	CARBON	6.8K 5% 1/4W
R946	1-249-431-11	CARBON	15K 5% 1/4W
R947	1-249-437-11	CARBON	47K 5% 1/4W
< VARIABLE RESISTOR >			
RV101	1-241-630-11	RES, ADJ, CARBON 10K (DOLBY LEVEL L)	
RV201	1-241-630-11	RES, ADJ, CARBON 10K (DOLBY LEVEL R)	
RV601	1-241-765-11	RES, ADJ, CARBON 22K (PITCH CONTROL) (WE505,WE705S)	
RV901	1-241-797-11	RES, VAR, CARBON 20K (AUTO REC LEVEL)	
RV902	1-225-173-11	RES, VAR, CARBON 50K (PITCH CONTROL) (WE505,WE705S)	
< SWITCH >			
△ S001	1-762-581-11	SWITCH, AC POWER PUSH (1 KEY) (POWER) (WE505,WE705S)	
S801	1-554-118-00	SWITCH, PUSH (1 KEY) (POWER) (WA7ESA,WE605S,WR550Z)	
S911	1-554-303-21	SWITCH, TACTILE (■ CLEAR)	
S912	1-554-303-21	SWITCH, TACTILE (▷ FRONT)	
S913	1-554-303-21	SWITCH, TACTILE (◁ BACK)	
S914	1-554-303-21	SWITCH, TACTILE (◀)	
S915	1-554-303-21	SWITCH, TACTILE (▶)	
S916	1-554-303-21	SWITCH, TACTILE (REC)	
S917	1-554-303-21	SWITCH, TACTILE (RESET)	
S918	1-554-303-21	SWITCH, TACTILE (MEMORY)	
S921	1-554-303-21	SWITCH, TACTILE (■)	
S922	1-554-303-21	SWITCH, TACTILE (PAUSE)	
S923	1-554-303-21	SWITCH, TACTILE (▷)	
S924	1-554-303-21	SWITCH, TACTILE (◁)	
S925	1-554-303-21	SWITCH, TACTILE (REC MUTE)	
S926	1-554-303-21	SWITCH, TACTILE (◀ /-RMS+)	
S927	1-554-303-21	SWITCH, TACTILE (▶ /-RMS+)	
S928	1-554-118-00	SWITCH, PUSH (1 KEY)(PITCH CONTROL) (WE505,WE705S)	
S931	1-554-303-21	SWITCH, TACTILE (RESET)	
S932	1-554-303-21	SWITCH, TACTILE (MEMORY)	
S933	1-554-303-21	SWITCH, TACTILE (FADER) (WE605S,WE705S)	
S934	1-554-303-21	SWITCH, TACTILE (ARL) (WE605S,WE705S)	
S935	1-554-303-21	SWITCH, TACTILE (SYNCHRO) (WE605S, WE705S)	
S935	1-554-303-21	SWITCH, TACTILE (ARL) (WA7ESA,WE505, WR550Z)	
S936	1-762-567-11	SWITCH, SLIDE (DOLBY NR)	
S937	1-762-609-11	SWITCH, SLIDE (DOLBY NR) (EXCEPT WE505)	
S937	1-762-608-11	SWITCH, SLIDE (DOLBY NR) (WE505)	
S938	1-554-303-21	SWITCH, TACTILE (FADER) (WA7ESA,WE505, WR550Z)	
S941	1-554-303-21	SWITCH, TACTILE (DISPLAY/START )	

Ref. No.	Part No.	Description	Remark
S942	1-554-303-21	SWITCH, TACTILE (RMS/START)	
S943	1-554-303-21	SWITCH, TACTILE (CHECK)	
S944	1-554-303-21	SWITCH, TACTILE (SET)	
S945	1-554-303-21	SWITCH, TACTILE (AUTO CAL/START )	
S946	1-554-303-21	SWITCH, TACTILE (HIGH/NORMAL)	
S947	1-762-609-11	SWITCH, SLIDE (DIRECTION MODE)	
< TEST PIN >			
TP801	1-560-060-00	PIN, CONNECTOR 2P	
< INDICATOR TUBE >			
VFD901	1-517-263-11	INDICATOR TUBE, FLUORESCENT	
< VIBRATOR >			
X801	1-579-175-11	VIBRATOR, CERAMIC (10MHZ)	
*****			
*	1-634-841-14	LEAF SW BOARD (DECK A) (WA7ESA,WE705S)	
*	1-638-020-11	LEAF SW BOARD (DECK A) (WE505,WE605S, WR550Z)	
*****			
< CONNECTOR >			
CNP81	1-568-850-11	SOCKET, CONNECTOR 7P (WE505,WE605S, WR550Z)	
CNP81	1-568-852-11	SOCKET, CONNECTOR 9P (WA7ESA,WE705S)	
< IC >			
IC81	8-749-924-10	IC NJL5165K-B (H1)	
IC82	8-749-924-10	IC NJL5165K-B (H1) (WA7ESA,WE705S)	
< RESISTOR >			
R84	1-249-417-11	CARBON	1K 5% 1/4W
R85	1-249-408-11	CARBON	180 5% 1/4W
R86	1-249-408-11	CARBON	180 5% 1/4W (WA7ESA, WE705S)
< SWITCH >			
S81	1-571-958-11	SWITCH, PUSH (1 KEY) (STOP)	
S82	1-571-281-21	SWITCH, LEAF (CR02)	
S86	1-571-281-21	SWITCH, LEAF (HALF)	
*****			
*	1-634-841-14	LEAF SW BOARD (DECK B) (WA7ESA,WE705S)	
*	1-638-020-11	LEAF SW BOARD (DECK B) (WE505,WE605S, WR550Z)	
*****			
< CONNECTOR >			
CNP81	1-568-850-11	SOCKET, CONNECTOR 7P (WE505,WE605S, WR550Z)	

The components identified by mark △ or dotted line with mark △ are critical for safety. Replace only with part number specified.

Les composants identifiés par une marque △ sont critiques pour la sécurité. Ne les remplacer que par une pièce portant le numéro spécifié.



**LEAF SW (DECK B)**

Ref. No.	Part No.	Description	Remark
* CNP81	1-568-852-11	SOCKET, CONNECTOR 9P (WA7ESA,WE705S)	
		< IC >	
IC81	8-749-924-10	IC NJL5165K-B (H1)	
IC82	8-749-924-10	IC NJL5165K-B (H1) (WA7ESA,WE705S)	
		< RESISTOR >	
R81	1-249-414-11	CARBON 560 5% 1/4W	
R82	1-247-818-11	CARBON 300 5% 1/4W	
R83	1-247-834-11	CARBON 1.3K 5% 1/4W	
R84	1-249-417-11	CARBON 1K 5% 1/4W	
R85	1-249-408-11	CARBON 180 5% 1/4W	
R86	1-249-408-11	CARBON 180 5% 1/4W (WA7ESA,WE705S)	
		< SWITCH >	
S81	1-571-958-11	SWITCH, PUSH (1 KEY) (STOP)	
S82	1-571-281-21	SWITCH, LEAF (CrO2)	
S83	1-571-281-21	SWITCH, LEAF (METAL)	
S84	1-571-281-21	SWITCH, LEAF (ERASER PROOF (SIDE A))	
S85	1-571-281-21	SWITCH, LEAF (ERASER PROOF (SIDE A))	
S86	1-571-281-21	SWITCH, LEAF (HALF)	
*****			
MISCELLANEOUS			
*****			
△ 9	1-551-188-99	CORD, POWER (E)	
△ 9	1-558-945-21	CORD, POWER (POLAR.SPT-1) (US,CND,PA)	
△ 9	1-575-651-21	CORD, POWER (AEP,G,MY,SP,CH)	
△ 9	1-696-586-11	CORD, POWER (UK)	
△ 9	1-696-845-11	CORD, POWER (AUS)	
△ 10	1-569-007-11	ADAPTER, CONVERSION 2P (E)	
△ 10	1-569-008-21	ADAPTER, CONVERSION 2P (CH)	
85	1-769-882-11	WIRE (FLAT TYPE) (7 CORE) (WE505,WE605S,WR550Z)	
65	1-769-912-11	WIRE (FLAT TYPE) (9 CORE) (WA7ESA,WE705S)	
74	1-769-598-11	WIRE (FLAT TYPE) (41 CORE)	
121	1-638-983-11	MOTOR FLEXIBLE BOARD	
HP101	A-2004-526-A	DECK ASSY, HEAD (PLAYBACK) (WE505,WE605S,WR550Z)	
HP101	A-2004-548-A	DECK ASSY, HEAD (PLAYBACK) (WA7ESA,WE705S)	
HRPE101A-2004-527-A		DECK ASSY, HEAD (RECORD/PLAYBACK/ERASE)	
M1	X-3365-377-2	MOTOR ASSY (CAPSTAN)	
M2	X-3365-501-2	MOTOR ASSY (REEL)	
△ S701	1-692-155-11	SELECTOR, POWER VOLTAGE (VOLTAGE SELECTOR) (E)	

Ref. No.	Part No.	Description	Remark
△ T801	1-427-782-11	TRANSFORMER, POWER (US,CND,PA)	
△ T801	1-427-783-11	TRANSFORMER, POWER (AEP,UK,G,AUS,MY,SP,CH)	
△ T801	1-427-784-11	TRANSFORMER, POWER (E)	
*****			
ACCESSORIES & PACKING MATERIALS			
*****			
	1-473-598-11	REMOTE COMMANDER (RM-J910) (WA7ESA :CND)	
	1-551-734-11	CORD, CONNECTION	
△	1-569-007-11	ADAPTER, CONVERSION 2P (E)	
△	1-569-008-21	ADAPTER, CONVERSION 2P (CH)	
	3-798-411-11	MANUAL, INSTRUCTION (ENGLISH/FRENCH/SPANISH/PORTUGUESE) (AEP)	
	3-798-411-21	MANUAL, INSTRUCTION (ENGLISH) (UK)	
	3-798-411-41	MANUAL, INSTRUCTION (GERMAN/DUTCH/SWEDISH/ITALIAN) (AEP)	
	3-798-411-51	MANUAL, INSTRUCTION (GERMAN) (G)	
	3-810-716-11	MANUAL, INSTRUCTION (ENGLISH) (US,CND,AUS,PA)	
	3-810-716-21	MANUAL, INSTRUCTION (FRENCH) (CND)	
	3-810-716-61	MANUAL, INSTRUCTION (ENGLISH/FRENCH/SPANISH/CHINESE) (E,MY,SP,CH)	
	3-810-765-11	MANUAL(CONTROL-A1),INSTRUCTION (ENGLISH) (WE605S:US,AUS,PA)	
	3-810-765-21	MANUAL(CONTROL-A1),INSTRUCTION (ENGLISH/FRENCH/SPANISH/GERMAN/DUTCH/SWEDISH/ITALIAN/PORTUGUESE/CHINESE) (WE605S:CND,E,MY,SP,CH)	
*	3-932-083-01	CUSHION (EXCEPT WA7ESA)	
*	3-934-283-01	CARTON, INDIVIDUAL (WE505)	
*	3-934-284-01	CARTON, INDIVIDUAL (WE605S:US,CND,E,AUS,PA)	
*	3-936-086-01	CUSHION (WA7ESA)	
*	3-934-285-01	CARTON, INDIVIDUAL (WE705S)	
*	3-934-287-01	CARTON, INDIVIDUAL (WA7ESA)	
*	3-935-092-01	INDIVIDUAL CARTON-(WE605S:MY,SP,CH)	
*	3-935-644-01	INDIVIDUAL CARTON (WR550Z)	
	4-981-643-01	COVER BATTERY (FOR RM-J910) (WA7ESA :CND)	
*****			

Ref. No.	Part No.	Description	Remark
*****			
HARDWARE LIST			
*****			
#1	7-682-548-04	SCREW +BVTT 3X8 (S)	
#2	7-685-871-01	SCREW +BVTT 3X6 (S)	
#3	7-685-646-79	SCREW +BVTP 3X8 TYPE2 N-S	
#4	7-685-134-19	SCREW (+ PTPWH) (2.6X8)	
#5	7-621-773-95	SCREW +BVTT 2.6X6 (S)	
#6	7-621-775-00	SCREW +B 2.6X3	
#7	7-627-556-08	SCREW +P 2.6X2.8	

The components identified by mark △ or dotted line with mark △ are critical for safety. Replace only with part number specified.	Les composants identifiés par une marque △ sont critiques pour la sécurité. Ne les remplacer que par une pièce portant le numéro spécifié.
--	--