

TC-WE405/WR350Z/WR661

SERVICE MANUAL

US Model
Canadian Model
TC-WE405/WR350Z/WR661

AEP Model
UK Model

E Model
TC-WE405/WR661

Australian Model
Chinese Model
TC-WE405

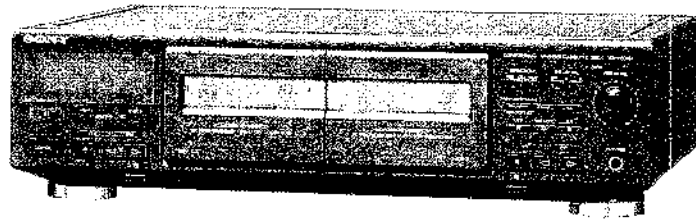



Photo : TC-WE405

Dolby noise reduction and HX Pro headroom extension manufactured under license from Dolby Laboratories Licensing Corporation. HX Pro originated by Bang & Olufsen.

"DOLBY", the double-D symbol  and "HX PRO" are trademarks of Dolby Laboratories Licensing Corporation.

TC-WE405

Model Name Using Similar Mechanism	TC-WR445	
Tape Transport Mechanism	DECK-A	TCM-220WR1
Type	DECK-B	

TC-WR350Z/WR661

Model Name Using Similar Mechanism	NEW	
Tape Transport Mechanism	DECK-A	TCM-220WR4E
Type	DECK-B	

System

Recording system

4-track 2-channel stereo

Fast-winding time (approx.)

180 sec. (with Sony C-60 cassette)

Bias

AC bias

Signal-to-noise ratio (at peak level and weighted with Dolby NR off)

Type I tape, Sony Type I (NORMAL): 55 dB

Type II tape, Sony Type II (HIGH): 57 dB

Type IV tape, Sony Type IV (METAL): 58 dB

S/N ratio improvement (approximate values)

With Dolby B NR on: 5 dB at 1 kHz, 10 dB at 5 kHz

With Dolby C NR on: 15 dB at 500 Hz, 20 dB at 1 kHz

Harmonic distortion

0.4% (with Type I tape, Sony Type I (NORMAL):
160 nWb/m 315 Hz, 3rd H.D.)

1.8% (with Type IV tape, Sony Type IV (METAL):
250 nWb/m 315 Hz, 3rd H.D.)

SPECIFICATIONS

Frequency response (Dolby NR off)

Type I tape, Sony Type I (NORMAL): 30 - 16,000 Hz
(± 3 dB, IEC)

Type II tape, Sony Type II (HIGH): 30 - 17,000 Hz
(± 3 dB, IEC)

Type IV tape, Sony Type IV (METAL): 30 - 19,000 Hz
(± 3 dB, IEC)

30 - 13,000 Hz (± 3 dB, -4 dB recording)

Type I tape, Sony Type I (NORMAL): 20 - 17,000 Hz
(± 6 dB)

Type II tape, Sony Type II (HIGH): 20 - 18,000 Hz
(± 6 dB)

Type IV tape, Sony Type IV (METAL): 20 - 20,000 Hz
(± 6 dB)

Wow and flutter

$\pm 0.15\%$ W. Peak (IEC)

0.1% W. RMS (NAB)

$\pm 0.2\%$ W. Peak (DIN)

— Continued on next page —

STEREO CASSETTE DECK
SONY[®]



SAFETY CHECK-OUT

Inputs

Line inputs (phono jacks)

Sensitivity: 0.16 V
Input impedance: 47 kilohms

Outputs

Line outputs (phono jacks)

Rated output level: 0.5 V at a load impedance of
47 kilohms
Load impedance: Over 10 kilohms

Headphones (stereo phone jack) (TC-WE405 only)

Output level: 0.25 mW at a load impedance of
32 ohms

General

Power requirements

Where purchased	Power requirements
US, Canadian model	120 V AC, 60 Hz
AEP, UK, German, Italian, Singapore, Malaysia, Chinese model	220 - 230 V AC, 50/60 Hz
Australian model	240 V AC, 50/60 Hz
E model	120/220/240 V AC, 50/60 Hz

Power consumption

18 W

Dimensions (approx) (w/h/d)

430 x 120 x 305 mm (w/h/d)
(17 x 4 3/4 x 12 1/4 inches)
including projecting parts and controls

Mass (approx.)

3.8 kg (8 lbs 7 oz)

Supplied accessories

Audio connecting cords (2 phono plugs - 2 phono
plugs) (2)

Optional accessory

Remote commander RM-J910

Design and specifications are subject to change without
notice.

After correcting the original service problem, perform
the following safety checks before releasing the set to the
customer:

Check the antenna terminals, metal trim, "metallized"
knobs, screws, and all other exposed metal parts for AC
leakage. Check leakage as described below.

LEAKAGE

The AC leakage from any exposed metal part to earth
ground and from all exposed metal parts to any exposed
metal part having a return to chassis, must not exceed 0.5
mA (500 microamperes). Leakage current can be measured
by any one of three methods.

1. A commercial leakage tester, such as the Simpson 229
or RCA WT-540A. Follow the manufacturers'
instructions to use these instruments.
2. A battery-operated AC milliammeter. The Data
Precision 245 digital multimeter is suitable for this job.
3. Measuring the voltage drop across a resistor by means
of a VOM or battery-operated AC voltmeter. The
"limit" indication is 0.75 V, so analog meters must
have an accurate low-voltage scale. The Simpson 250
and Sanwa SH-63Trd are examples of a passive VOM
that is suitable. Nearly all battery operated digital
multimeters that have a 2V AC range are suitable. (See
Fig. A)

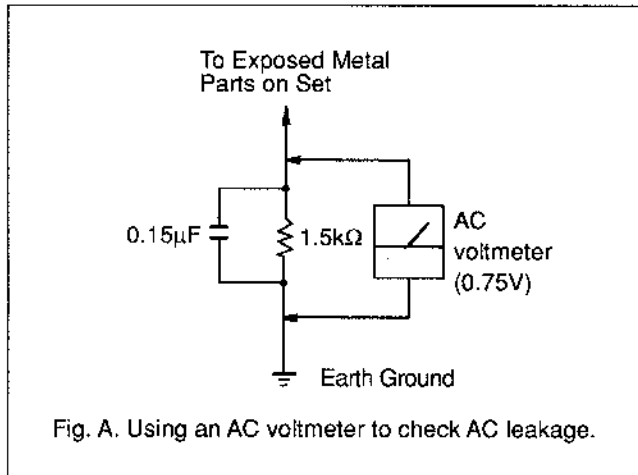

Fig. A. Using an AC voltmeter to check AC leakage.

SAFETY-RELATED COMPONENT WARNING !!

COMPONENTS IDENTIFIED BY MARK Δ OR DOTTED
LINE WITH MARK Δ ON THE SCHEMATIC DIAGRAMS
AND IN THE PARTS LIST ARE CRITICAL TO SAFE
OPERATION. REPLACE THESE COMPONENTS WITH
SONY PARTS WHOSE PART NUMBERS APPEAR AS
SHOWN IN THIS MANUAL OR IN SUPPLEMENTS
PUBLISHED BY SONY.

ATTENTION AU COMPOSANT AYANT RAPPORT À LA SÉCURITÉ!!

LES COMPOSANTS IDENTIFIÉS PAR UNE MARQUE Δ
SUR LES DIAGRAMMES SCHÉMATIQUES ET LA LISTE
DES PIÈCES SONT CRITIQUES POUR LA SÉCURITÉ
DE FONCTIONNEMENT. NE REMPLACER CES
COMPOSANTS QUE PAR DES PIÈCES SONY DONT
LES NUMÉROS SONT DONNÉS DANS CE MANUEL OU
DANS LES SUPPLÉMENTS PUBLIÉS PAR SONY.

SERVICE NOTE

[FL Display Tube All Lit and Key Check mode]

Insert a short-chip into TP801 (2P) and turn ON the power switch. At first, all the FL display tube light up, then the system returns to normal display.

After that, press one of to enter the KEY CHECK mode. The number of FL display tube is light every pressing a button in the KEY CHECK mode.

MODEL IDENTIFICATION

— BACK PANEL —



TC-WE405

MODEL	PARTS No.
US	3-931-433-0□
CND	3-931-433-1□
AEP, G, MY, SP, CH	3-931-433-2□
UK	3-931-433-3□
E	3-931-433-4□
AUS	3-931-433-5□

TC-WR350Z

MODEL	PARTS No.
US	3-934-887-0□
CND	3-934-887-1□

TC-WR661

MODEL	PARTS No.
US	3-931-436-0□
CND	3-931-436-1□
AEP, G, IT	3-931-436-2□
UK	3-931-436-3□
E	3-931-436-4□

- Abbreviation
 - CND : Canadian model.
 - G : German model.
 - IT : Italian model.
 - SP : Singapore model.
 - MY : Malaysia model.
 - AUS : Australian model.
 - CH : Chinese model.

TABLE OF CONTENTS

Section	Title	Page
SECTION 1. GENERAL		4
SECTION 2. DISASSEMBLY		
2-1.	Front Panel	5
2-2.	Mechanism Deck	5
SECTION 3. ADJUSTMENTS		
3-1.	Mechanical Adjustments	6
3-2.	Electrical Adjustments	6
	Record/Playback Head Azimuth Adjustment	
	Deck-A Deck-B	6
	Tape Speed Adjustment Deck-B	7
	Playback Level Adjustment Deck-A Deck-B	7
	Bias Consumption Current Adjustment Deck-B	8
	Record Bias Adjustment Deck-B	8
	Record Level Adjustment Deck-B	8
SECTION 4. DIAGRAMS		
4-1.	Circuit Boards Location	10
4-2.	IC Pin Function	
	• IC801 System Controller (M38172M4-156FP)	11
4-3.	Printed Wiring Board — Deck (TCM-220WR1) Section — TC-WE405	13
4-4.	Schematic Diagram — Deck (TCM-220WR1) Section — TC-WE405	15
4-5.	Printed Wiring Board — Deck (TCM-220WR4E) Section — TC-WR350Z/WR661	17
4-6.	Schematic Diagram — Deck (TCM-220WR4E) Section — TC-WR350Z/WR661	19
4-7.	Printed Wiring Board — Main Section —	21
4-8.	Schematic Diagram — Main Section —	25
SECTION 5. EXPLODED VIEWS		
5-1.	Case Section	29
5-2.	Front Panel Section	30
5-3.	TC Mechanism Section 1 (WE405 : TCM-220WR1) (WR350Z/WR661 : TCM-220WR4E)	31
5-4.	TC Mechanism Section 2 (WE405 : TCM-220WR1) (WR350Z/WR661 : TCM-220WR4E)	32
5-5.	TC Mechanism Section 3 (WE405 : TCM-220WR1) (WR350Z/WR661 : TCM-220WR4E)	33
SECTION 6. ELECTRICAL PARTS LIST		34

SECTION 1 GENERAL

LOCATION OF CONTROL

Front Panel

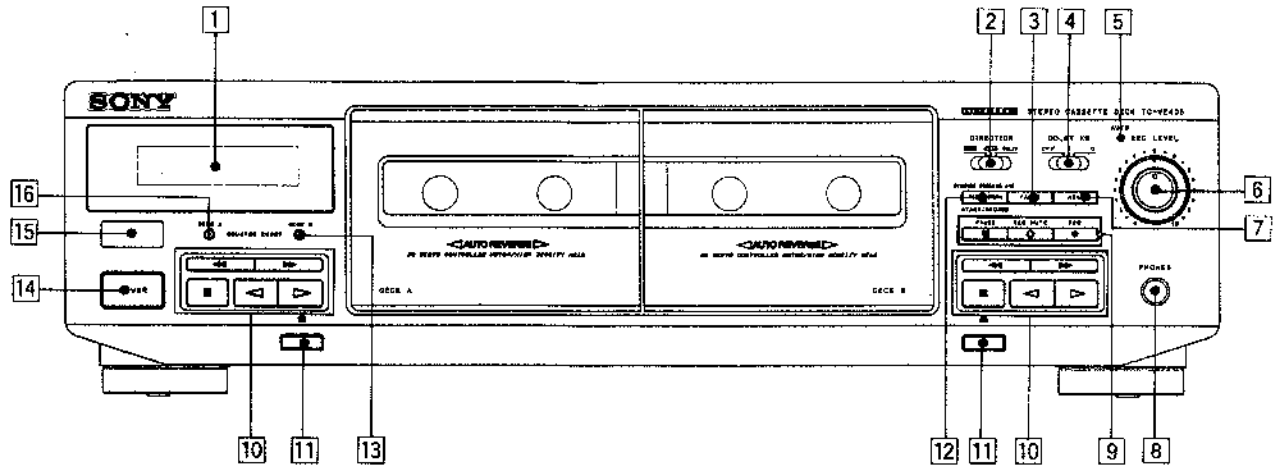

- | | |
|--|--|
| <p>1 Display panel and Indicator tube</p> <p>2 DIRECTION switch</p> <p>3 FADER button</p> <p>4 DOLBY NR (Dolby noise reduction) switch</p> <p>5 AUTO Indicator</p> <p>6 REC (recording) LEVEL control</p> <p>7 ARL button</p> <p>8 PHONES (headphones) jack (stereo phone jack) (TC-WE405 only)</p> <p>9 Tape operation buttons</p> <p> ■ PAUSE button</p> <p> ○ REC MUTE button</p> <p> ● REC button</p> | <p>10 Tape operation buttons</p> <p> ■ (stop) button</p> <p> ◁ (reverse play) button</p> <p> ▷ (forward play) button</p> <p> ◀◀ (fast-forwarding) button</p> <p> ▶▶ (rewinding) button</p> <p>11 ▲ OPEN/CLOSE button</p> <p>12 SYNCHRO DUBBING A → B button</p> <p> HIGH Speed button</p> <p> NORMAL Speed button</p> <p> START (DECK B) button</p> <p>13 COUNTER RESET DECK B button</p> <p>14 POWER switch</p> <p>15 Remote control sensor</p> <p>16 COUNTER RESET DECK A button</p> |
|--|--|

SECTION 2 DISASSEMBLY

Note : Follow the disassembly procedure in the numerical order given.

2-1. FRONT PANEL

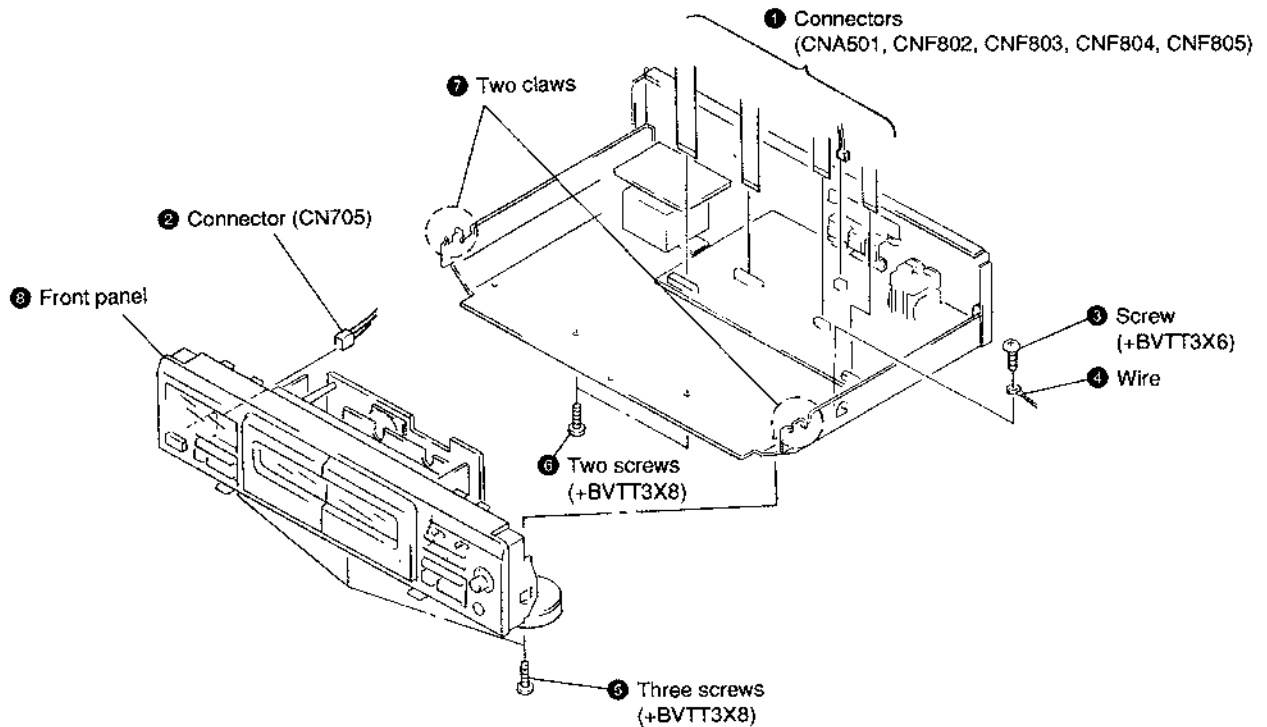

2-2. MECHANISM DECK

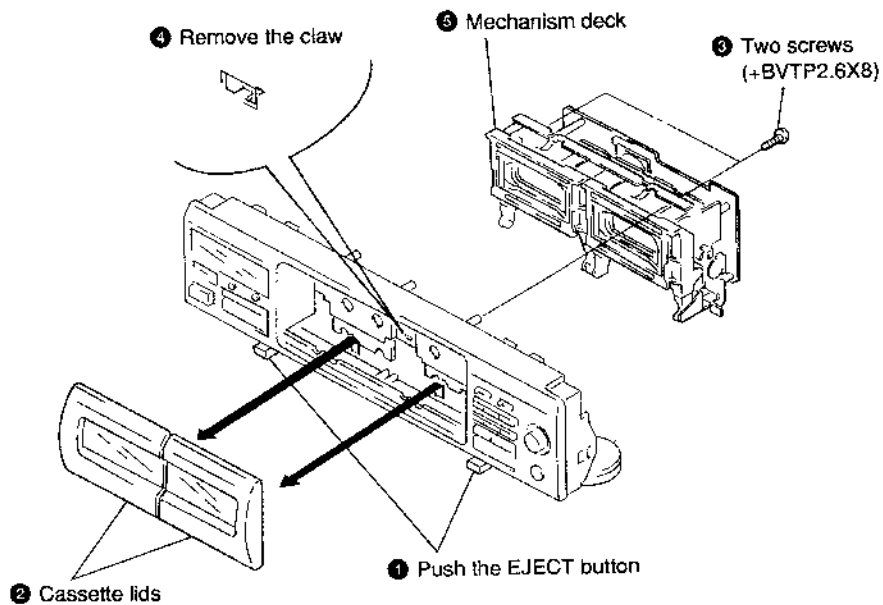

SECTION 3 ADJUSTMENTS

3-1. MECHANICAL ADJUSTMENTS

PRECAUTION

1. Clean the following parts with a denatured alcohol-moistened swab :
 - record/playback/erase head pinch roller
 - rubber belts capstan
 - idlers
2. Demagnetize the record/playback head with a head demagnetizer.
3. Do not use a magnetized screwdriver for the adjustment.
4. After the adjustments, apply suitable locking compound to the parts adjusted.
5. The adjustments should be performed with the rated power supply voltage unless otherwise noted.

Torque Measurement

Torque	Torque meter	Meter reading
FWD	CQ-102C	36 to 61g • cm (0.5 – 0.84 oz • inch)
FWD back tension	CQ-102C	2 to 6g • cm (0.02 – 0.08 oz • inch)
REV	CQ-102RC	36 to 61g • cm (0.5 – 0.84 oz • inch)
REV back tension	CQ-102RC	2 to 6g • cm (0.02 – 0.08 oz • inch)
FF/REW	CQ-201B	61 to 143g • cm (0.85 – 1.99 oz • inch)
FWD tension	CQ-403A	100g • cm or more (1.39 oz • inch or more)
REV tension	CQ-403R	100g • cm or more (1.39 oz • inch or more)

3-2. ELECTRICAL ADJUSTMENTS

PRECAUTION

1. The adjustment should be performed in the publication.
(Be sure to make playback adjustment at first.)
2. The adjustments and measurement should be performed for both L-CH and R-CH.
 - Switch position
DOLBY NR switch : OFF
DIRECTION switch :
 - Standard record position :
Deliver the standard input signal level to input jack and set the REC LEVEL control to obtain the standard output signal level as follows.

— Record Mode —

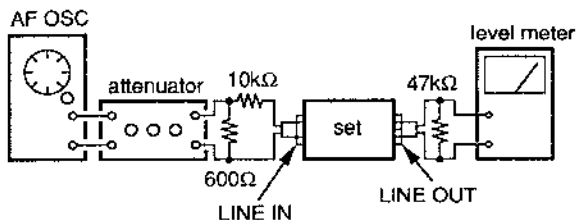

Input Terminal	LINE IN
source impedance	10kΩ
input signal level	0.5 V (-3.8 dB)

Standard Output Level

Output Terminal	LINE OUT
load impedance	47kΩ
output signal level	0.5 V (-3.8 dB)

Test Tape

Tape	Contents	Use
P-4-A100	10 kHz, -10 dB	Azimuth Adjustment
P-4-L300	315 Hz, 0 dB	PB Level Adjustment
WS-48B	3 kHz, 0 dB	Tape Speed Adjustment

$0dB = 0.775V$

Test mode

1. Insert a short-clip into TP801 (2P) and turn ON the power switch.
At first, all the fluorescent tubes light up, then the system returns to normal display.
2. To release the test mode, remove the short-clip and turn off the power switch.
3. Remove the short-clip after completion of adjustment.

Record/Playback Head Azimuth Adjustment

DECK-A **DECK-B**

Procedure :

1. Forward playback Mode

test tape
P-4-A100
(10kHz, -10dB)

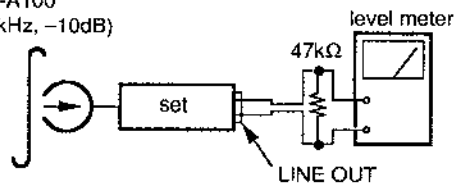

2. Turn the adjustment screw for the maximum output levels. If these levels do not match, turn the adjustment screw until both of output levels match together within 1 dB.

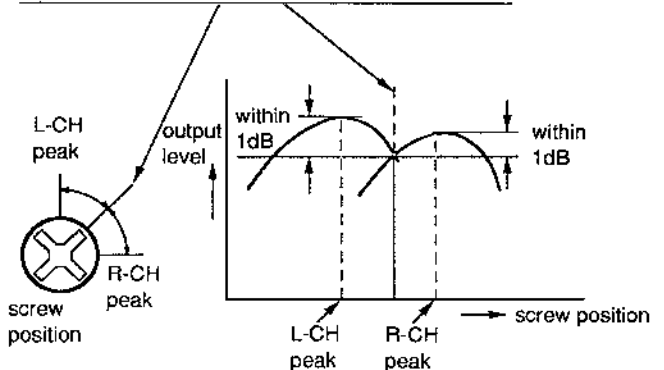

3. Playback Mode

test tape
P-4-A100
(10kHz, -10dB)

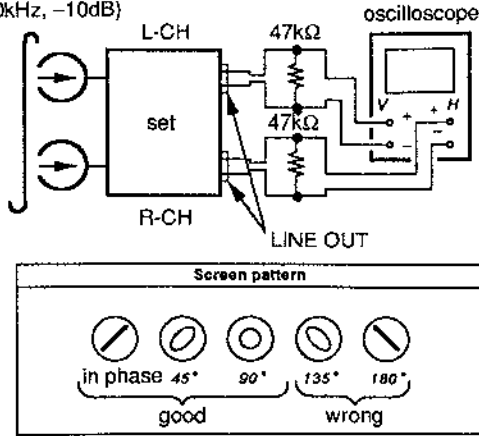

4. Change the reverse playback mode and repeat the steps 1 to 3.
5. After the adjustment, lock the adjustment screws with suitable locking compound.

Adjustment Location : — Record/Playback head —

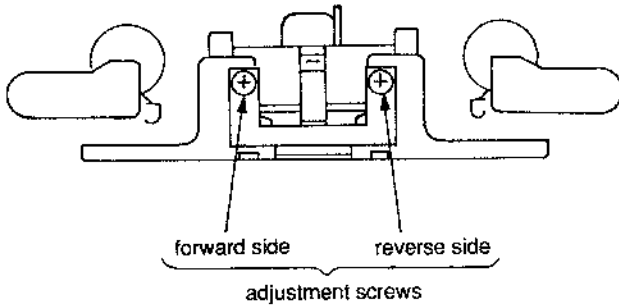

Tape Speed Adjustment **DECK-B**

Procedure :

Mode : Forward Playback

test tape
WS-48B
(3kHz, 0dB)

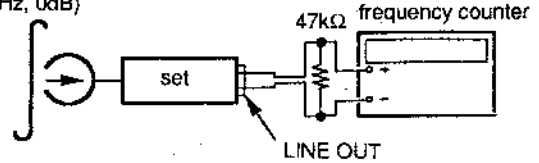

(high speed adjustment)

1. Set to test mode. (See page 6)
2. Insert the WS-48B to the deck B to playback.
3. Set to Forward playback mode.
4. Press the **SYNCHRO DUBBING** button.
5. Adjust RV652 so that the frequency counter reading becomes $6,000 \pm 30$ Hz.

(Press the **SYNCHRO DUBBING** button again to be set the normal speed mode.)

(normal speed adjustment)

1. Set to FWD playback mode.
2. Adjust RV651 so that the frequency counter reading becomes $3,010 \pm 10$ Hz.

Frequency difference between FWD mode and REV mode should be within 55 Hz.

Adjustment Location : MD board

Playback Level Adjustment **DECK-A** **DECK-B**

Procedure :

Mode : Forward Playback

test tape
P-4-L300
(315kHz, 0dB)

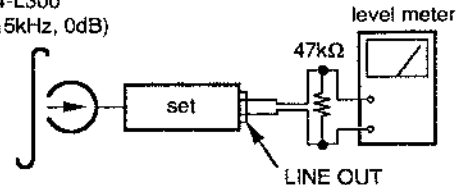

Adjust deck-A is RV311 (L-CH) and RV411 (R-CH), deck-B is RV301 (L-CH) and RV401 (R-CH) so that adjustment within the following adjustment level.

Adjustment level :

LINE OUT level : $-7.7 \text{ dB} \pm 0.5 \text{ dB}$ (301.5 to 338.3 mV)

Level difference between channels : within $\pm 0.5 \text{ dB}$.

Confirm the LINE OUT level does not change in playback mode while changing the mode from playback to stop several times.

Adjustment Location : MD board

Bias Consumption Current Adjustment **DECK-B**

(TC-WE405 only)

This adjustment should be performed when replacing the head assy or the bias oscillating transformer (T341, T441).

Procedure :

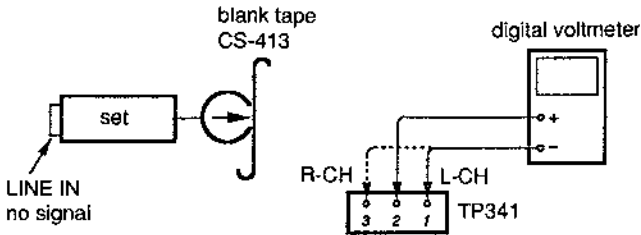

1. Connect the digital voltmeter to test point TP341.
2. Set RV341 (L-CH) and RV441 (R-CH) to mechanical center.
3. Set to FWD record mode..
4. Adjust T341 (L-CH) and T441 (R-CH) so that the digital voltmeter reading becomes minimum.

Adjustment level : Maximum 220 mV

Adjustment level : MD board

Record Bias Adjustment **DECK-B**

Setting :

REC LEVEL control : standard record position
(Refer to page 6.)

Procedure :

1. Mode : record

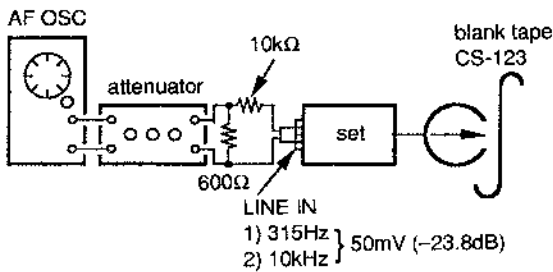

2. Mode : Playback

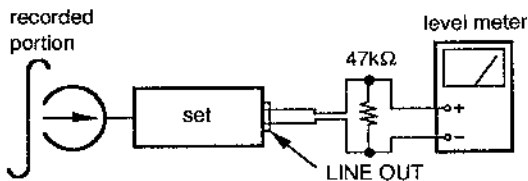

Confirm playback the signal recorded in step1 become adjustment level as follows. If these levels do not adjustment level the RV341 (L-CH) and RV441 (R-CH) to repeat step 1 and 2.

Adjustment level :

The playback output of 10 kHz level difference should be ± 0.5 dB.

Adjustment Location : MD board

Record Level Adjustment **DECK-B**

Setting :

REC LEVEL control : standard record position
(Refer to page 6.)

Procedure :

1. Mode : Record

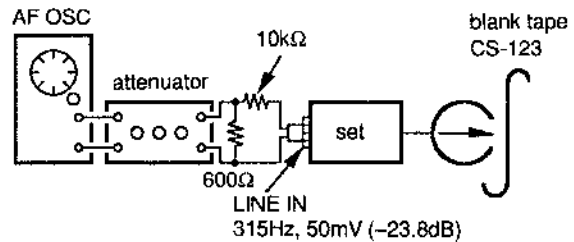

2. Mode : Playback

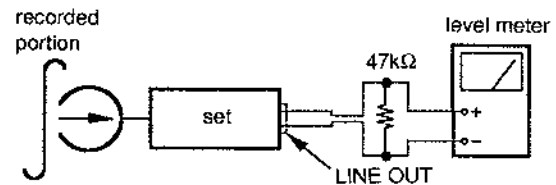

Confirm playback the signal recorded in step 1 become adjustment level as follows.

If necessary, adjust RV101 (L-CH) and RV201 (R-CH) to repeat the step 1 and 2.

Adjustment level : -23.8 ± 0.5 dB (47.2 to 53.0 mV)

Adjustment Location : MAIN (A) board

— Adjustment Location —

[MAIN (A) BOARD] (Component side)

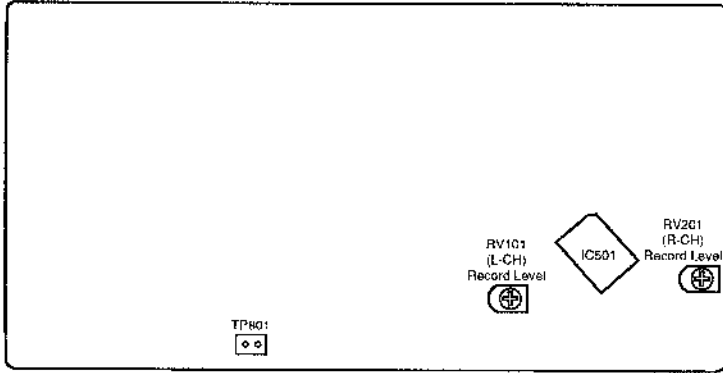

[MD BOARD] (Conductor Side)

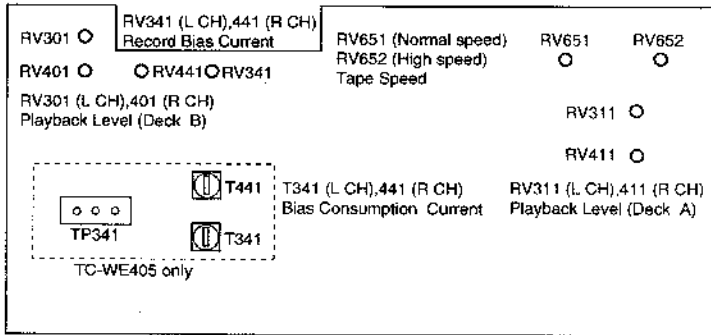

SECTION 4 DIAGRAMS

4-1. CIRCUIT BOARDS LOCATION

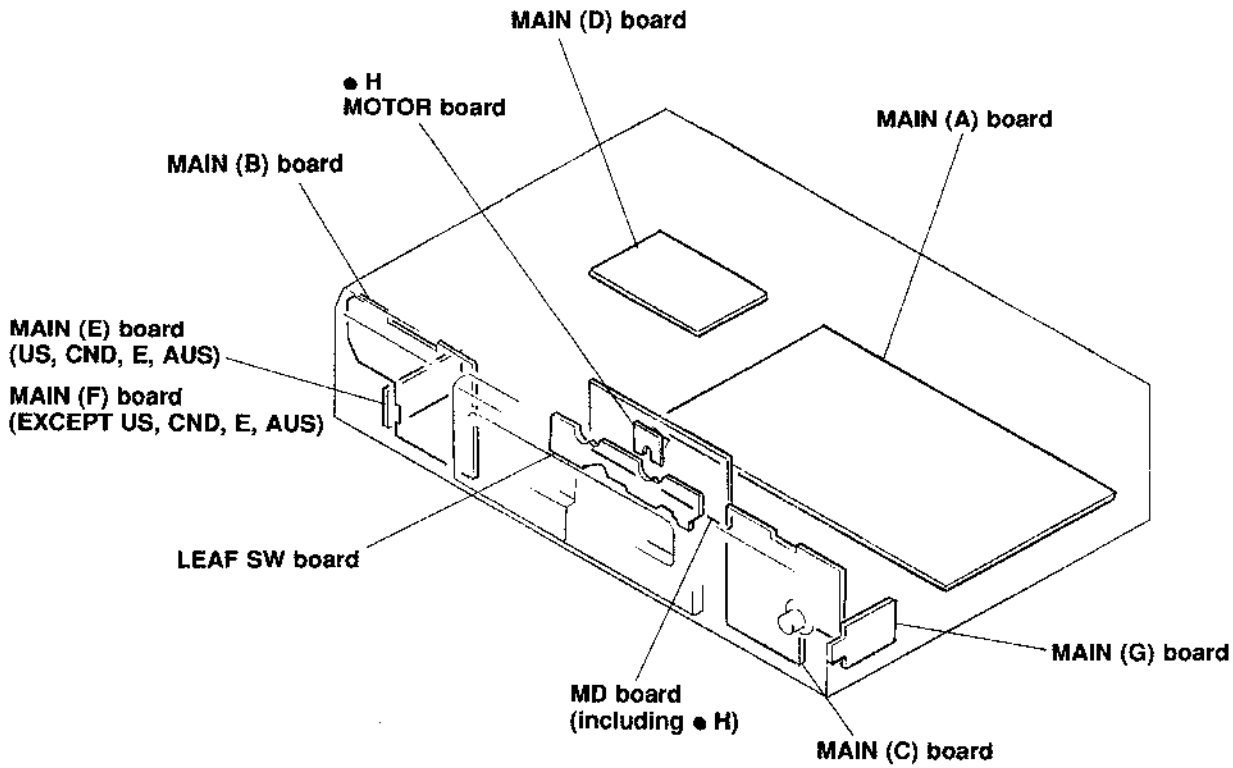

NOTE : ● H is including in MD board.

- Abbreviation
CND : Canadian model.
AUS : Australian model.

4-2. IC PIN FUNCTION

• IC801 System Controller (M3B172M4-156FP)

Pin No.	Pin Name	I/O	Function
1	REC VOL IN (A/B)	I	REC volume input
2	METER (L)	I	Meter input Lch
3	METER (R)	I	Meter input Rch
4	B HALF	I	Half, REC claw A side and B side detect - DECK B -
5	A HALF	I	Half detect - DECK A -
6	A PLAY	I	Play mode on - DECK A -
7	A SHUT	I	} Reel table pulse detect - DECK A -
8	A SCHMIT	O	
9	B SHUT	I	} Reel table pulse detect - DECK B -
10	B SCHMIT	O	
11	B TV	I	TYPE 4 detect L: TYPE 1, 2, H: TYPE 4 - DECK B -
12	B PLAY	I	H: Play mode on - DECK B -
13	PB SELECT (A/B)	O	PB amp select L: DECK A, H: DECK B
14	REC/PB	O	REC/PB mode select L: PB, H: REC
15	PB EQ (HIGH/NORM)	O	PB EQ select L: Norm Speed, H: High Speed
16	REC MUTE	O	REC mute L: Mute On, H: Cancel
17	LINE MUTE	O	LINE mute L: Mute On, H: Cancel
18	REC VOL OUT	O	PWM output REC volume control
19	NR/MUTE/PASS	O	NR IN/PASS mute select L: NR, H: PASS, Input: MUTE
20	B BIAS	O	L: Bias On, H: Off
21	POWER IN (2)	I	Secondary power detect L: Power Off, H: On
22	POWER IN (1)	I	Primary power detect L: Power Off, H: On
23	---	O	Open
24	SIRCS	I	Remote control receiver
25	POWER OUT	O	L: Power hold
26	---	I	Open (Connected to ground)
27	RESET	I	RESET
28	---	-	Open (Connected to ground)
29	---	-	Open
30	X IN	I	4 MHz clock input
31	X OUT	O	4 MHz clock output
32	V _{ss}	-	Ground
33	B RELAY	O	Relay select H: Off, L: On
34	TEST	I	L: Test mode
35	---	O	} Open
36	---	O	
37	---	O	
38	---	O	
39	---	O	
40	---	O	

Pin No.	Pin Name	I/O	Function
41	V1	O	FL Segment signal output 16
42	S15	O	FL Segment signal output 15
43	S14	O	FL Segment signal output 14
44	S13	O	FL Segment signal output 13
45	S12	O	FL Segment signal output 12
46	S11	O	FL Segment signal output 11
47	S10	O	FL Segment signal output 10
48	S9	O	FL Segment signal output 9
49	S8	O	FL Segment signal output 8
50	S7	O	FL Segment signal output 7
51	S6	O	FL Segment signal output 6
52	S5	O	FL Segment signal output 5
53	S4	O	FL Segment signal output 4
54	S3	O	FL Segment signal output 3
55	S2	O	FL Segment signal output 2
56	S1	O	FL Segment signal output 1
57	G1	O	FL Grid signal output 1
58	G2	O	FL Grid signal output 2
59	G3	O	FL Grid signal output 3
60	G4	O	FL Grid signal output 4
61	G5	O	FL Grid signal output 5
62	G6	O	FL Grid signal output 6
63	G7	O	FL Grid signal output 7
64	—	O	} Open
65	—	O	
66	CAP M ($\overline{H/N}$)	O	Capstan motor L: High Speed, H: Low Speed
67	CAP M ($\overline{ON/OFF}$)	O	Capstan motor L: On, H: Off
68	TRG ($\overline{H/L}$)	O	Trigger motor H: Low, L: High
69	A-TRG	O	Trigger motor control – DECK A –
70	B-TRG	O	Trigger motor control – DECK B –
71	—	O	Open
72	ARL (LED)	O	ARL LED control L: Off, H: On
73	Vcc	–	+5V
74	VEE	–	Pull down voltage –24V
75	AVss	–	AD voltage 0V (Ground)
76	VREF	–	AD Reference voltage +5V
77	KEY4	I	Key input (Arew, Aff, Breset, Circle, Relay, Oneway)
78	KEY3	I	Key input (Astp, Afwd, Arev, Areset)
79	KEY2	I	Key input (Brew, Bff, Brec, Bpause, Brec_mute, Dub H/N)
80	KEY1	I	Key input (Bstp, Bfwd, Brev, ARL, FADER)

• Abbreviation

FL : FLUORESCENT INDICATOR TUBE

4-3. PRINTED WIRING BOARD — DECK (TCM-220WR1) SECTION — TC-WE405

• See page 10 for Circuit Boards Location.

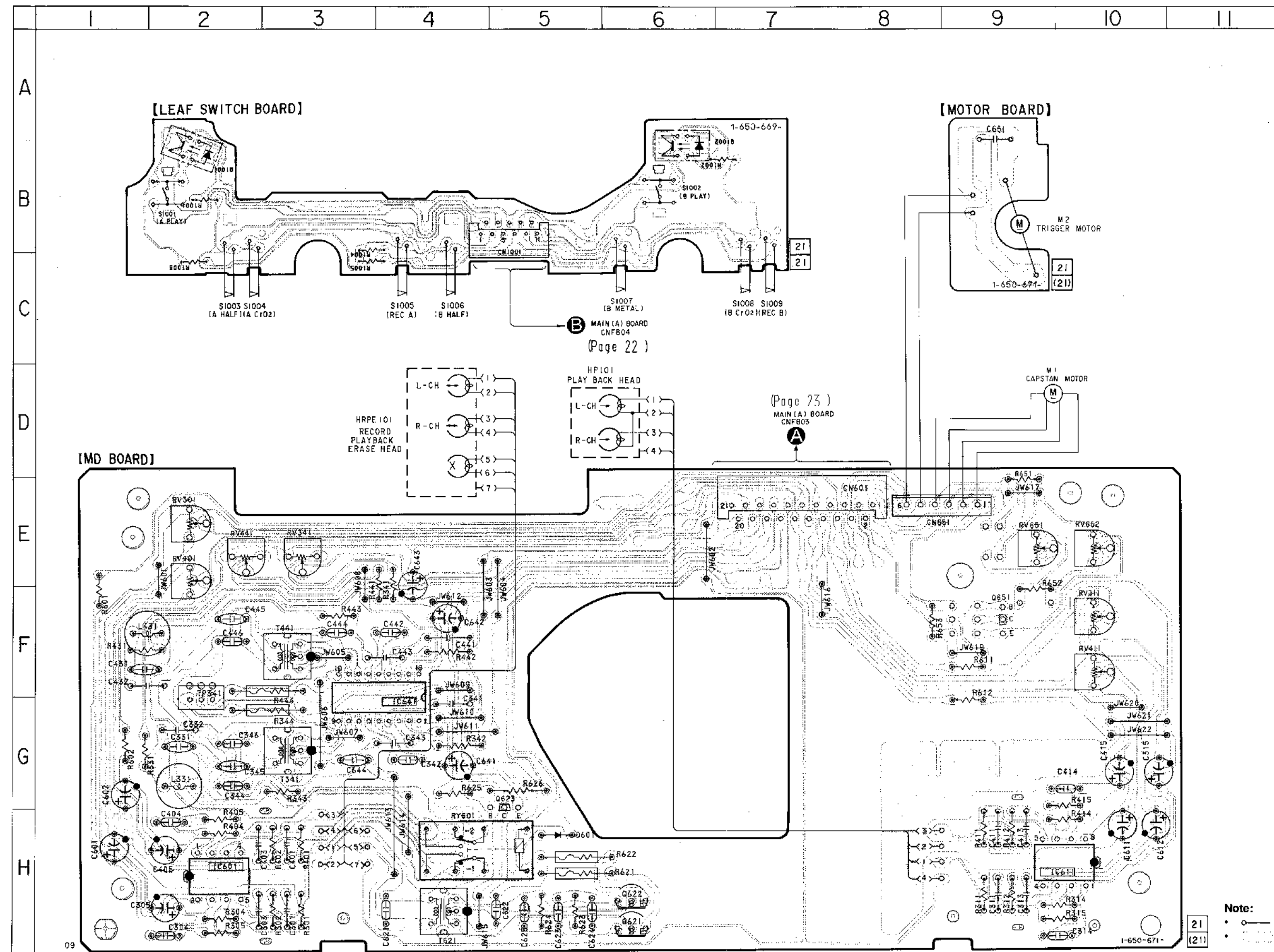

• Semiconductor Location

Ref. No.	Location
D601	H-5
IC601	H-2
IC611	H-10
IC641	G-4
Q621	H-6
Q622	H-6
Q623	G-5
Q651	F-9
Q1001	B-2
Q1002	B-6

Note:
 • ○ : parts extracted from the component side.
 • ○ : Pattern from the side which enable seeing.

4-4. SCHEMATIC DIAGRAM — DECK (TCM-220WR1) SECTION — TC-WE405

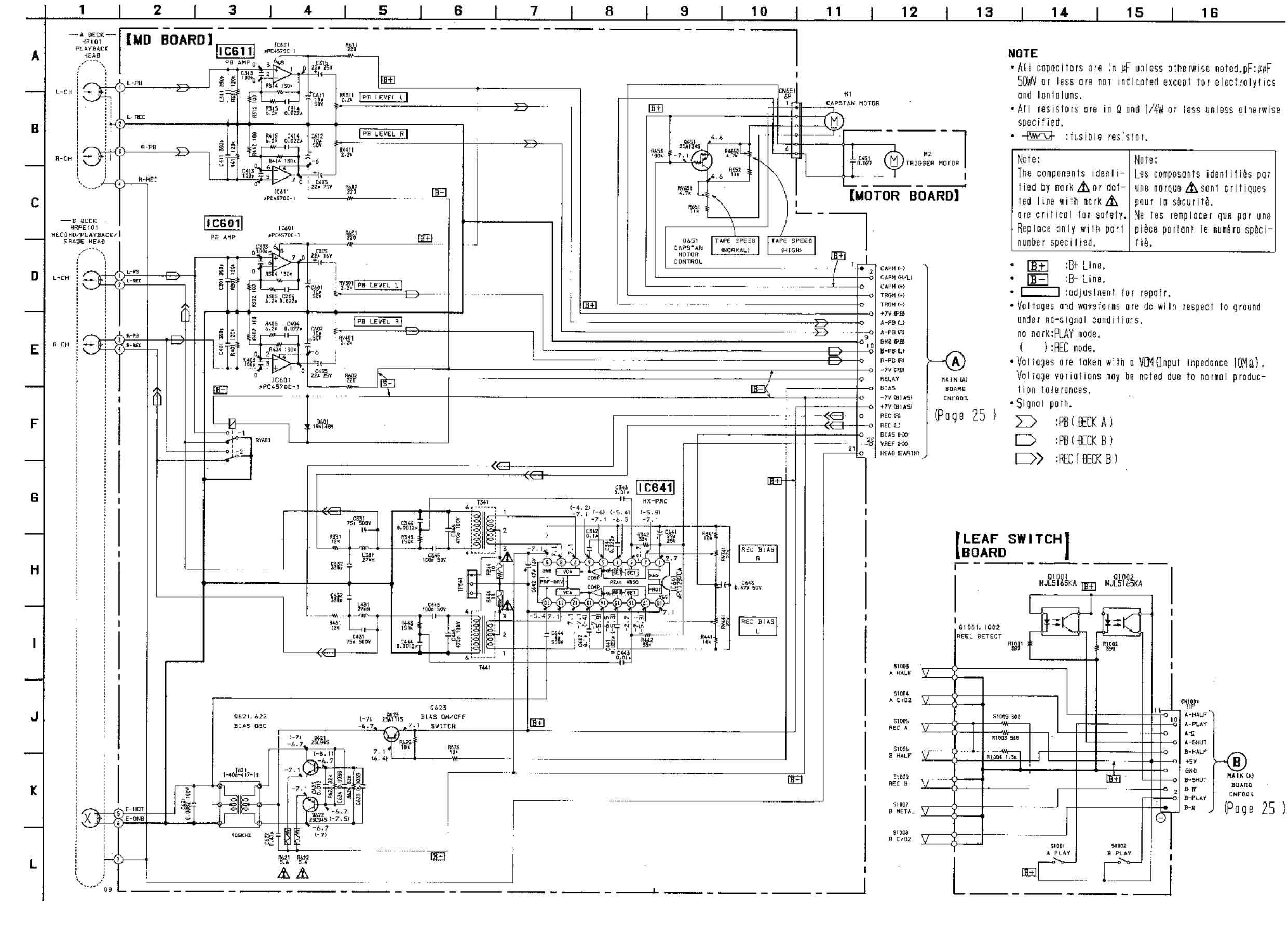

NOTE
 • All capacitors are in μF unless otherwise noted. μF : μF 50W or less are not indicated except for electrolytics and tantalums.
 • All resistors are in Ω and $1/4\text{W}$ or less unless otherwise specified.
 • --- : fusible resistor.

Note:
 The components identified by mark Δ or dotted line with mark Δ are critical for safety. Replace only with part number specified.

Note:
 Les composants identifiés par une marque Δ sont critiques pour la sécurité. Ne les remplacer que par une pièce portant le numéro spécifié.

- B+ : B+ Line.
- B- : B- Line.
- \square : adjustment for repair.
- Voltages and waveforms are dc with respect to ground under no-signal conditions, no mark: PLAY mode.
- () : REC mode.
- Voltages are taken with a VOM (input impedance $10\text{M}\Omega$). Voltage variations may be noted due to normal production tolerances.
- Signal path.
- \triangleright : PB (DECK A)
- \square : PB (DECK B)
- \triangleright : REC (DECK B)

4-5. PRINTED WIRING BOARD — DECK (TCM-220WR4E) SECTION — TC-WR350Z/WR661

• See page 10 for Circuit Boards Location.

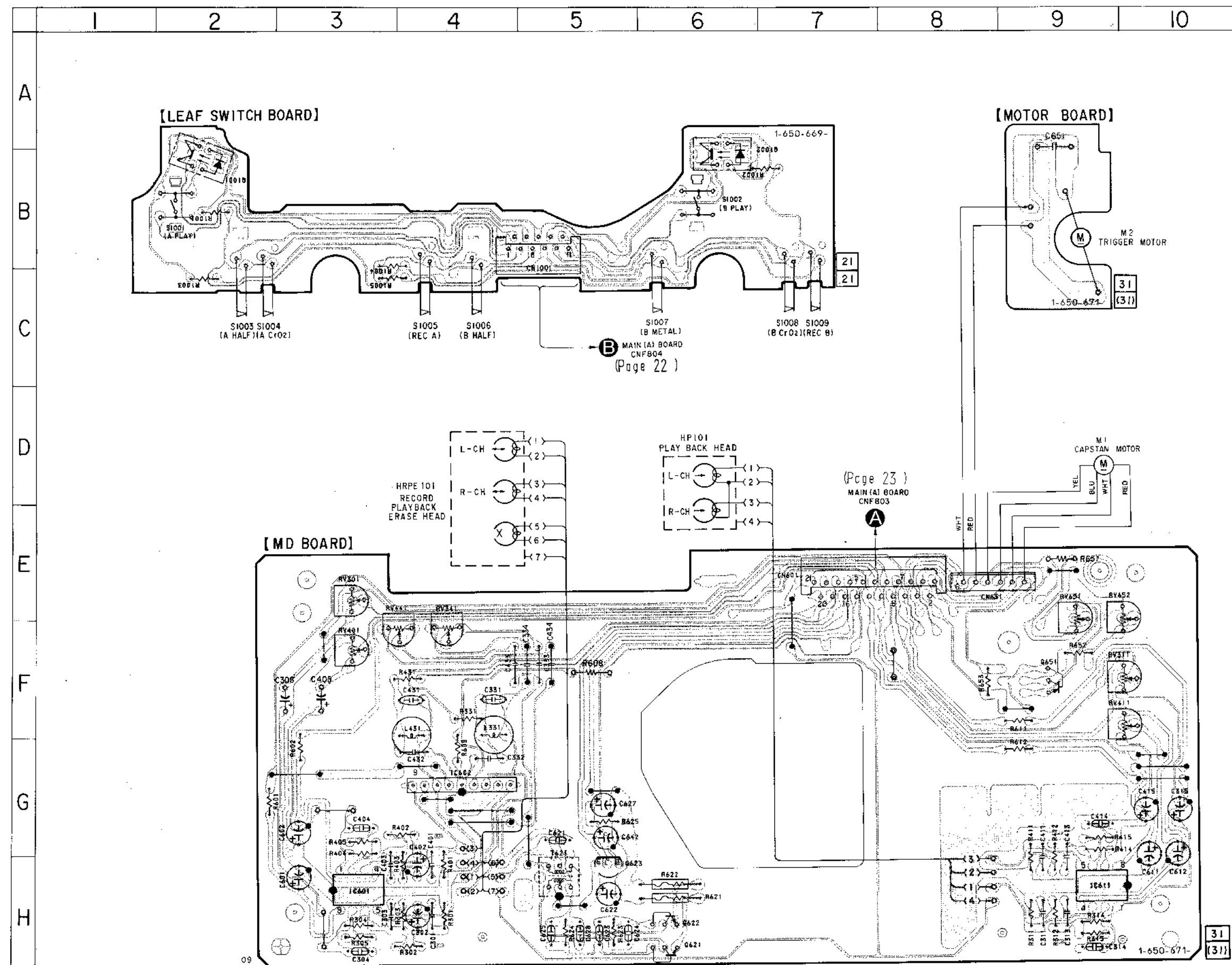

4-6. SCHEMATIC DIAGRAM — DECK (TCM-220WR4E) SECTION — TC-WR350Z/WR661

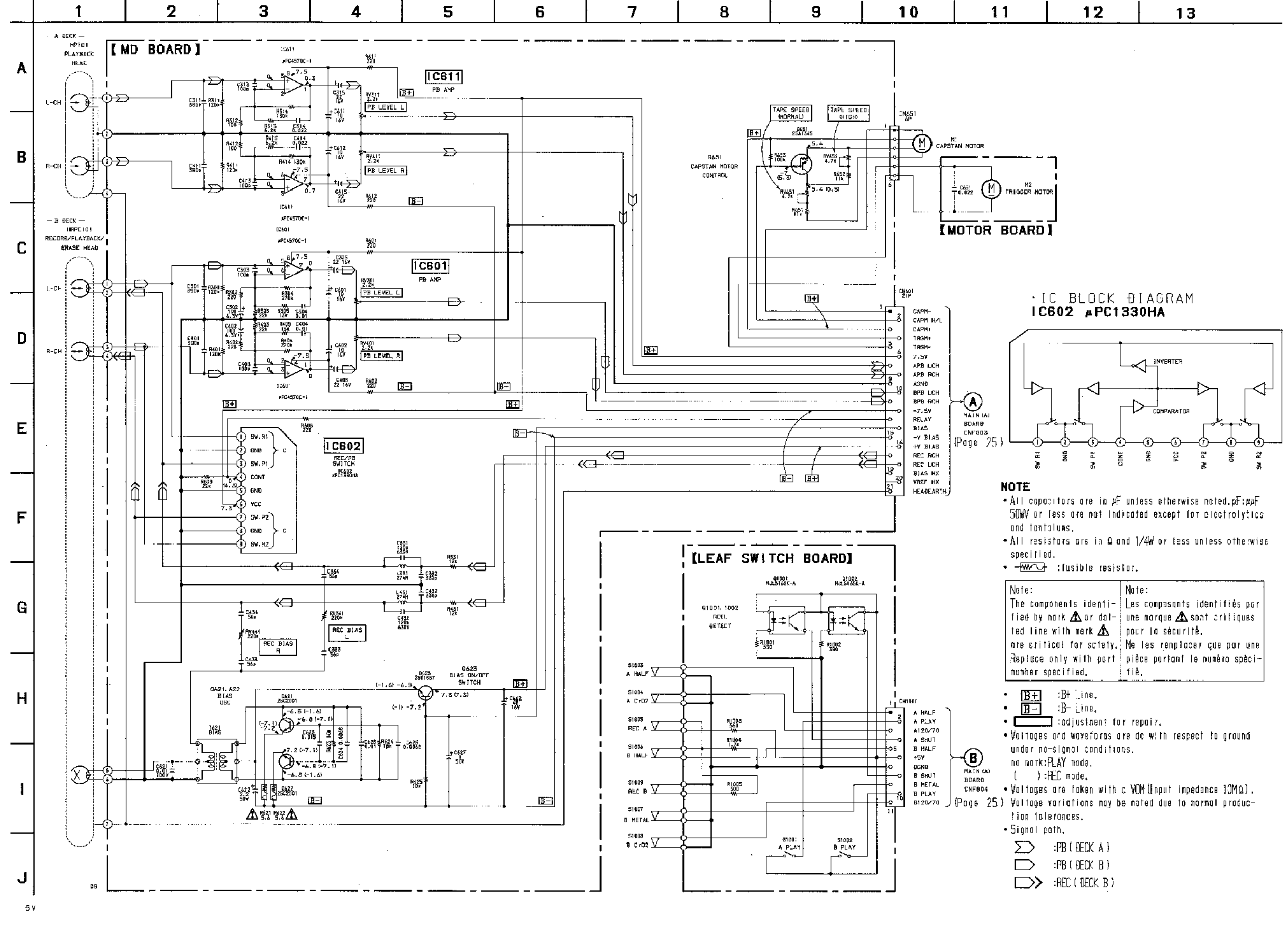

4-7. PRINTED WIRING BOARD — MAIN SECTION — TC-WR350Z/WR661
 • See page 10 for Circuit Boards Location.

• Semiconductor Location

Ref. No.	Location
D101	D-7
D201	D-7
D501	B-7
D701	C-12
D702	C-12
D703	B-12
D704	B-12
D705	B-12
D706	B-12
D707	C-12
D708	A-9
D709	B-9
D710	C-10
D711	B-9
D712	B-12
D713	G-12
D714	D-12
D715	D-11
D716	D-13
D718	C-8
D901	G-16
IC501	E-3
IC502	B-8
IC701	B-10
IC801	F-9
IC802	F-5
IC803	G-8
IC804	E-12
IC806	D-6
IC901	C-17
Q101	D-4
Q102	B-6
Q201	C-2
Q202	B-5
Q501	B-7
Q701	A-10
Q702	A-9
Q703	A-12
Q704	B-11
Q705	B-10
Q706	A-12
Q707	D-12
Q708	D-12
Q801	F-8
Q802	D-12
Q803	D-11
Q804	D-12
Q805	E-12
Q806	E-12
Q807	E-7
Q808	G-8

Note:
 • — : parts extracted from the component side.
 • ■ : parts mounted on the conductor side.
 • △ : internal component.
 • [Pattern] : Pattern from the side which enable seeing.
 • Abbreviation
 CND : Canadian model.
 AUS : Australian model.

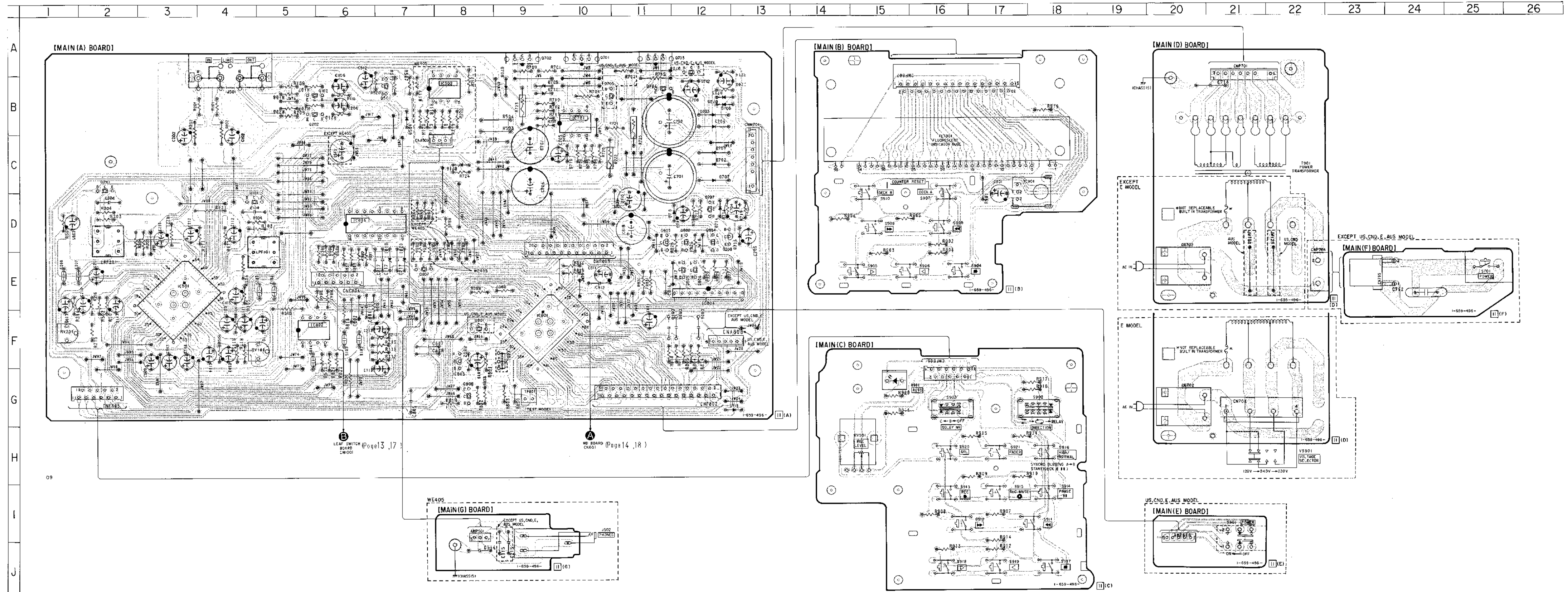

4-8. SCHEMATIC DIAGRAM — DECK (TCM-220WR4E) SECTION — TC-WR350Z/WR661
• See page 11 for IC Pin function. (IC801)

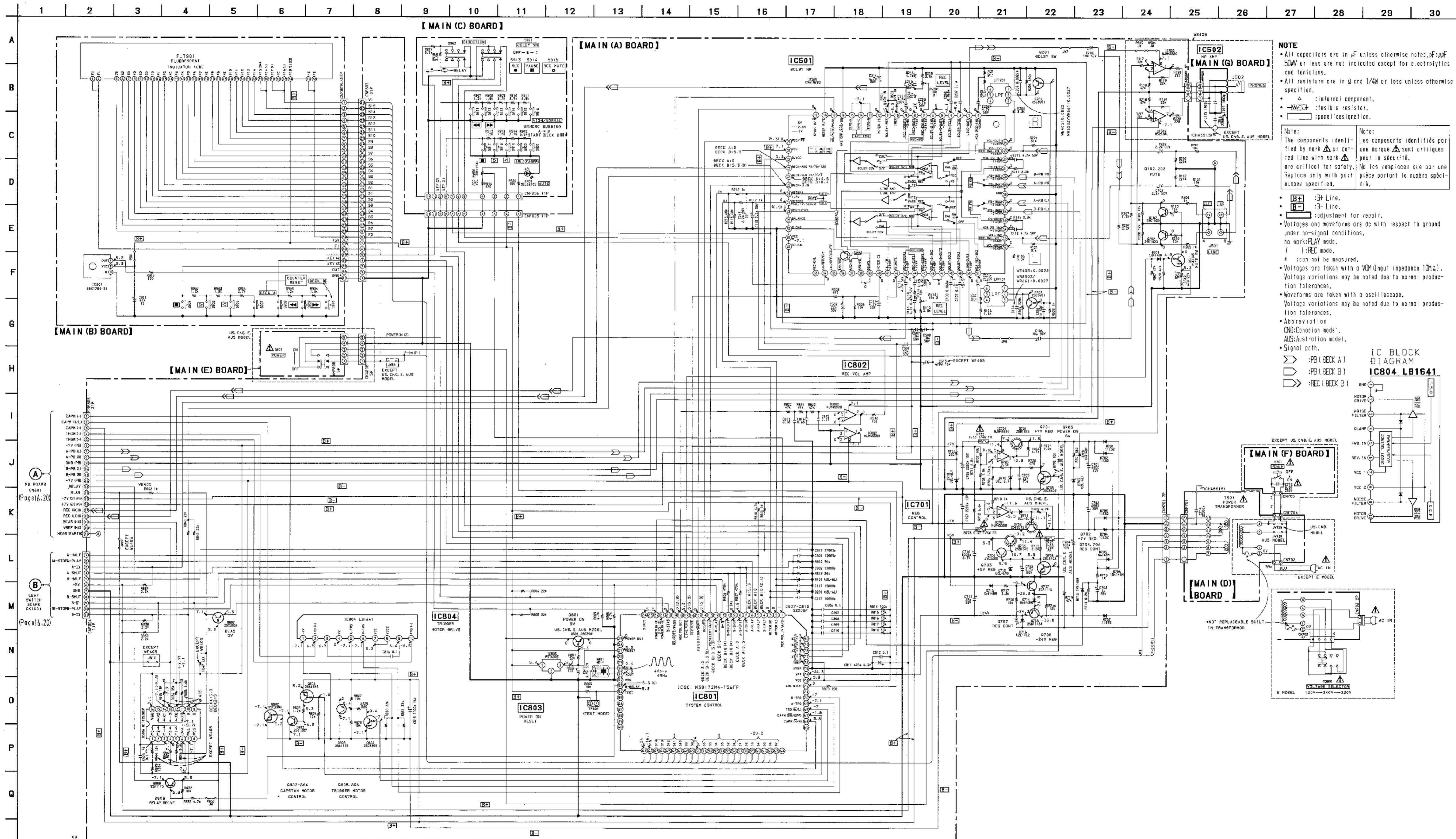

NOTE

- All capacitors are in μF unless otherwise noted. $\mu F = 10^{-6} F$. $50M\Omega$ or less are not indicated except for electrolytics and tantalums.
- All resistors are in Ω and $1/K\Omega$ or less unless otherwise specified.
- Δ : internal component.
- \square : fusible resistor.
- \square : panel designation.

Note:
The components identified by mark Δ or \square are critical for safety. Replace only with part number specified.

Note:
Les composants identifiés par une marque Δ sont critiques pour la sécurité. Ne les remplacer que par une pièce portant le numéro spécifié.

- \square : 3 Line.
- \square : 3 Line.
- \square : adjustment for repair.
- Voltages and waveforms are dc with respect to ground under no-signal conditions, no mark-PLAY mode.
- () : REC mode.
- * : can not be measured.
- Voltages are taken with a VOM (input impedance $10M\Omega$). Voltage variations may be noted due to normal production tolerances.
- Waveforms are taken with an oscilloscope. Voltage variations may be noted due to normal production tolerances.
- Abbreviation: CNB:Canadian model, AUS:Australia model.
- Signal path.

IC BLOCK DIAGRAM

IC804 LB1641

- \square : PB (DECK A)
- \square : PB (DECK B)
- \square : REC (DECK B)

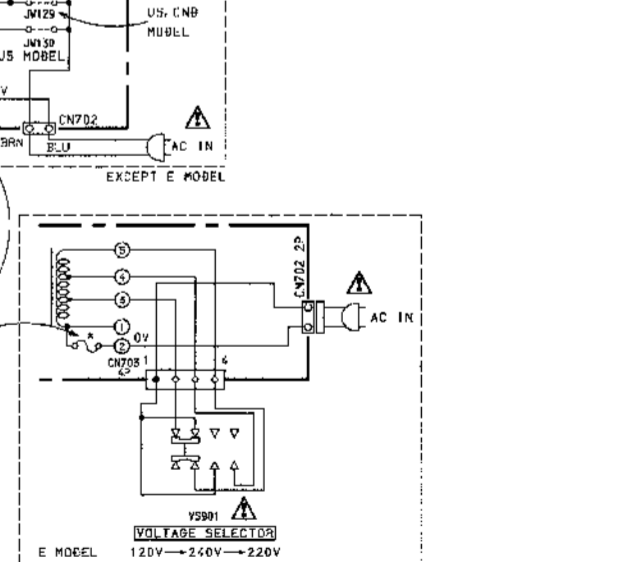
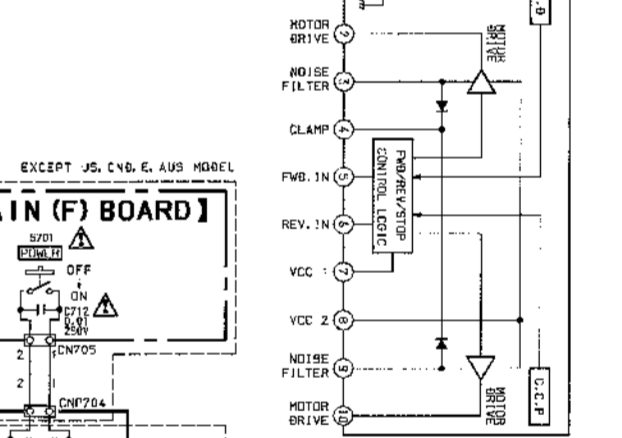

SECTION 5 EXPLODED VIEWS

NOTE:

- Items marked " * " are not stocked since they are seldom required for routine service. Some delay should be anticipated when ordering these items.
- The mechanical parts with no reference number in the exploded views are not supplied.
- Hardware (# mark) list and accessories and packing materials are given in the last of this parts list.

- Abbreviation
- CND : Canadian model
- G : German model
- IT : Italian model
- SP : Singapore model
- MY : Malaysia model
- AUS : Australian model
- CH : Chinese model

The components identified by mark \triangle or dotted line with mark \triangle are critical for safety.
Replace only with part number specified.

Les composants identifiés par une marque \triangle sont critiques pour la sécurité.
Ne les remplacer que par une pièce portant le numéro spécifié.

5-1. CASE SECTION

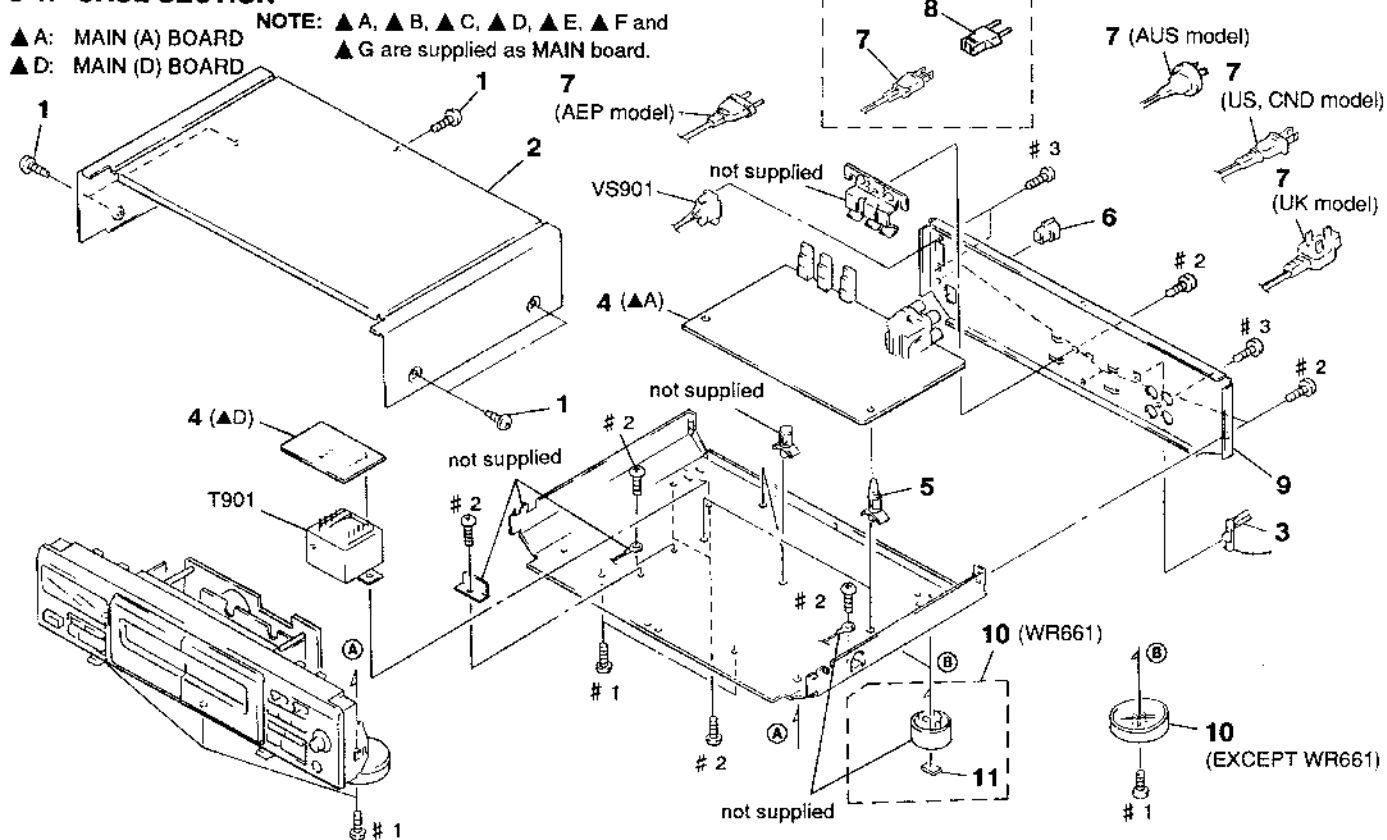

Ref. No.	Part No.	Description	Remark	Ref. No.	Part No.	Description	Remark
1	3-704-366-01	SCREW (CASE) (M3X8)		* 9	3-931-433-01	PANEL, BACK (WE405:US)	
* 2	3-931-432-01	CASE (410726)		* 9	3-931-433-11	PANEL, BACK (WE405:CND)	
3	4-956-370-12	BAND, PLUG FIXED (WE405:UK, AUS)		* 9	3-931-433-21	PANEL, BACK (WE405:AEP, CH, MY, SP, G)	
* 4	A-2007-484-A	MAIN BOARD, COMPLETE (WR350Z/WR661:US, CND)		* 9	3-931-433-31	PANEL, BACK (WE405:UK)	
* 4	A-2007-486-A	MAIN BOARD, COMPLETE (WR661:AEP, UK, G, IT)		* 9	3-931-433-41	PANEL, BACK (WE405:E)	
* 4	A-2007-487-A	MAIN BOARD, COMPLETE (WR661:E)		* 9	3-931-433-51	PANEL, BACK (WE405:AUS)	
* 4	A-2007-488-A	MAIN BOARD, COMPLETE (WE405:AEP, CH, MY, SP, UK, G)		* 9	3-931-436-01	PANEL, BACK (WR661:US)	
* 4	A-2007-489-A	MAIN BOARD, COMPLETE (WE405:E)		* 9	3-931-436-11	PANEL, BACK (WR661:CND)	
* 4	A-2007-490-A	MAIN BOARD, COMPLETE (WE405:AUS)		* 9	3-931-436-21	PANEL, BACK (WR661:AEP, G, IT)	
* 4	A-2007-546-A	MAIN BOARD, COMPLETE (WE405:US, CND)		* 9	3-931-436-31	PANEL, BACK (WR661:UK)	
* 5	3-346-265-31	HOLDER, PC BOARD		* 9	3-931-436-41	PANEL, BACK (WR661:E)	
* 6	3-703-244-00	BUSHING (2104), CORD (WE405:AEP, CH, MY, SP, UK, G, AUS/WR661:AEP, UK, G, IT)		* 9	3-934-887-01	PANEL, BACK (WR350Z:US)	
6	3-703-571-11	BUSHING (S) (4516), CORD (WE405:US, CND, E/WR350Z/WR661:US, CND, E)		* 9	3-934-887-11	PANEL, BACK (WR350Z:CND)	
\triangle 7	1-558-945-21	CORD, POWER (POLAR. SPT-1) (WE405:US, CND/WR350Z/WR661:US, CND)		10	X-3371-405-1	FOOT (SMALL) ASSY (WR661)	
\triangle 7	1-575-651-21	CORD, POWER (WE405:AEP, CH, MY, SP, G/WR661:AEP, G, IT)		10	X-3371-435-1	FOOT ASSY (F50150S) (WE405:AEP, CH, MY, SP, UK, G, E, AUS)	
\triangle 7	1-696-027-11	CORD, POWER (WE405:E/WR661:E)		10	X-3371-436-1	FOOT ASSY (F50145S) (WE405:US, CND/WR350Z)	
\triangle 7	1-696-845-11	CORD, POWER (WE405:AUS)		11	4-977-358-01	CUSHION (8X12.5) (WE405/WR350Z)	
\triangle 7	1-769-639-11	CORD, POWER (WR661:UK)		\triangle T901	429-387-11	TRANSFORMER, POWER (WE405:US, CND/WR350Z/WR661:US, CND)	
\triangle 7	1-751-523-11	CORD, POWER (WE405:UK)		\triangle T901	429-388-11	TRANSFORMER, POWER (WE405:AEP, CH, MY, SP, UK, G, AUS/WR661:AEP, UK, G, IT)	
\triangle 8	1-569-007-11	ADAPTER, CONVERSION 2P (WE405:E/WR661:E)		\triangle T901	429-389-11	TRANSFORMER, POWER (WE405:E/WR661:E)	
				\triangle VS901	692-155-11	SELECTOR, POWER VOLTAGE (WE405:E/WR661:E)	

5-2. FRONT PANEL SECTION

- ▲ B: MAIN (B) BOARD
- ▲ C: MAIN (C) BOARD
- ▲ E: MAIN (E) BOARD (US, CND, E, AUS model)
- ▲ F: MAIN (F) BOARD (EXCEPT US, CND, E, AUS model)
- ▲ G: MAIN (G) BOARD

NOTE: ▲ A, ▲ B, ▲ C, ▲ D, ▲ E, ▲ F and ▲ G are supplied as MAIN board.

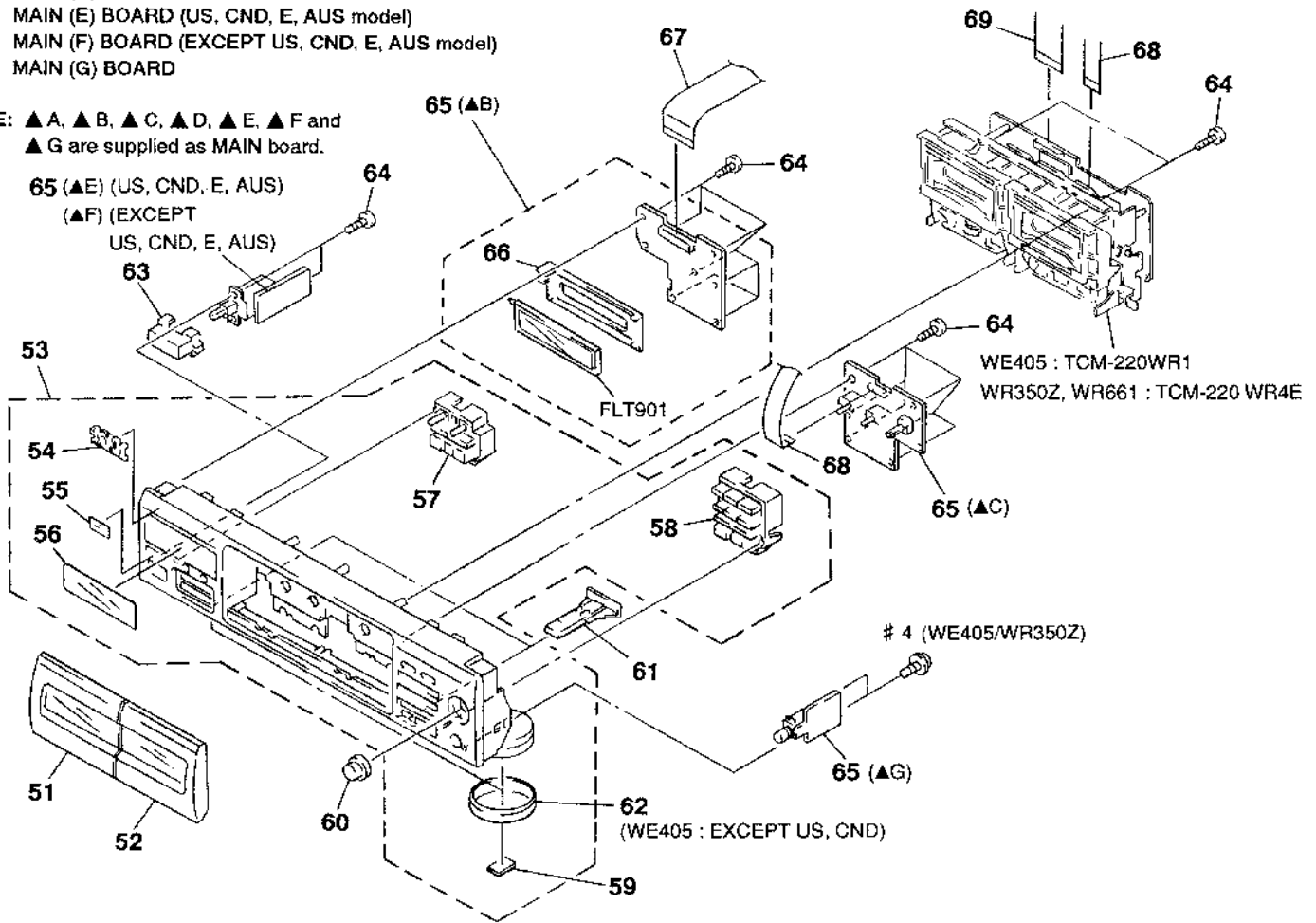

Ref. No.	Part No.	Description	Remark	Ref. No.	Part No.	Description	Remark
51	X-3371-403-1	LID (A) ASSY, CASSETTE		63	3-931-429-01	BUTTON (POWER)	
52	X-3371-404-1	LID (B) ASSY, CASSETTE		64	4-951-620-01	SCREW (2.6X8), +BVTP	
53	X-3371-400-1	PANEL ASSY, FRONT (WR350Z)		* 65	A-2007-484-A	MAIN BOARD, COMPLETE (WR350Z/WR661:US, CND)	
53	X-3371-401-1	PANEL ASSY, FRONT (WE405:US, CND)		* 65	A-2007-486-A	MAIN BOARD, COMPLETE (WR661:AEP, UK, G, IT)	
53	X-3371-402-1	PANEL ASSY, FRONT (WR661)		* 65	A-2007-487-A	MAIN BOARD, COMPLETE (WR661:E)	
53	X-3371-969-1	PANEL ASSY, FRONT (WE405:AEP, CH, MY, SP, UK, G, E, AUS)		* 65	A-2007-488-A	MAIN BOARD, COMPLETE (WE405:AEP, CH, MY, SP, UK, G)	
54	4-963-404-21	EMBLEM (5-A), SONY		* 65	A-2007-489-A	MAIN BOARD, COMPLETE (WE405:E)	
55	3-931-435-01	WINDOW (R)		* 65	A-2007-490-A	MAIN BOARD, COMPLETE (WE405:AUS)	
56	3-931-434-01	WINDOW (M)		* 65	A-2007-546-A	MAIN BOARD, COMPLETE (WE405:US, CND)	
57	3-931-425-01	BUTTON (A)		* 66	3-931-428-01	HOLDER (FL)	
58	3-931-426-01	BUTTON (B)		67	1-773-332-11	WIRE (FLAT TYPE) (31 CORE)	
59	4-977-358-01	CUSHION (8X12.5)		68	1-769-950-11	WIRE (FLAT TYPE) (11 CORE)	
60	3-931-430-11	KNOB (REC)		69	1-773-153-11	WIRE (FLAT TYPE) (21 CORE)	
61	3-931-427-01	BUTTON (EJ)		FLT901	1-517-491-11	INDICATOR TUBE, FLUORESCENT	
62	4-977-593-11	RING (DIA 50), ORNAMENTAL (WE405:AEP, CH, MY, SP, UK, G, E, AUS)					

5-3. TC MECHANISM SECTION 1
 (WE405: TCM-220WR1
 WR350Z, WR661: TCM-220WR4E)

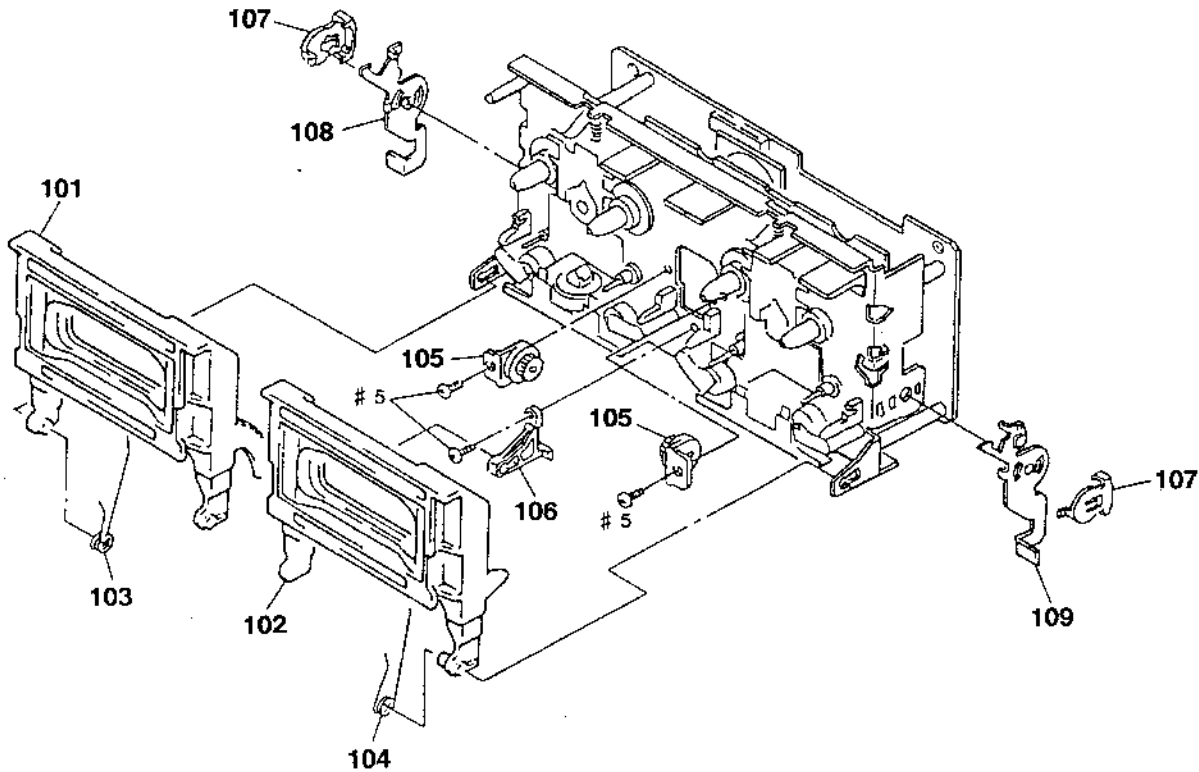

Ref. No.	Part No.	Description
101	X-4945-690-1	HOLDER (L) ASSY, CASSETTE
102	X-4945-691-1	HOLDER (R) ASSY, CASSETTE
103	4-959-231-11	SPRING (L), TORSION
104	4-959-232-11	SPRING (R), TORSION
105	3-354-963-01	DAMPER

Remark	Ref. No.	Part No.	Description	Remark
	* 106	4-980-439-01	FULCRUM, HOLDER	
	107	3-354-957-01	JOINT (LOCK LEVER)	
	* 108	3-354-953-01	LEVER (LOCK LEVER L)	
	* 109	3-354-954-01	LEVER (LOCK LEVER R)	

5-4. TC MECHANISM SECTION 2
 (WE405: TCM-220WR1
 WR350Z, WR661: TCM-220WR4E)

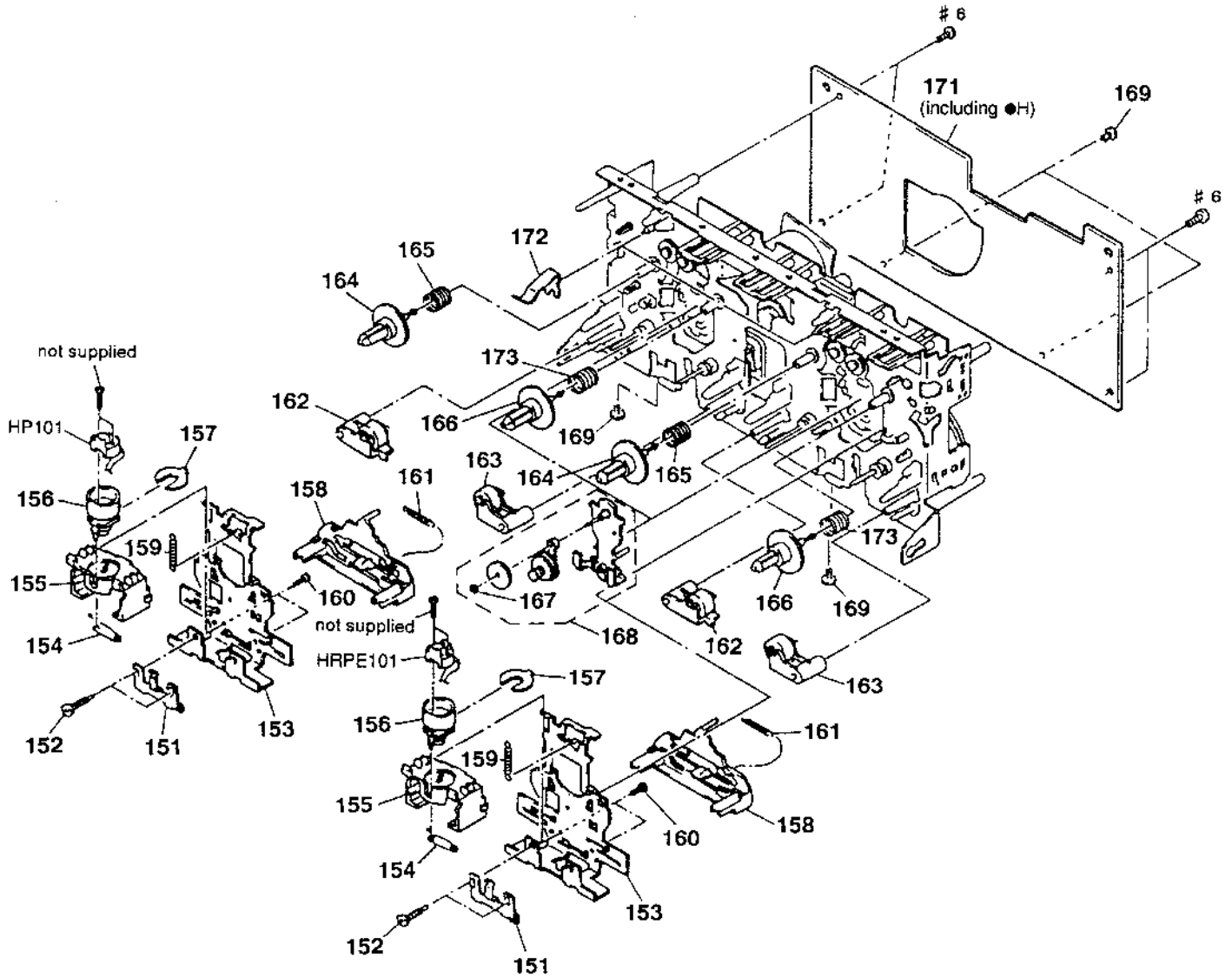

Ref. No.	Part No.	Description	Remark	Ref. No.	Part No.	Description	Remark
151	3-908-560-01	SPRING, AZIMUTH ADJUSTMENT		164	3-908-613-01	GEAR (S), REEL	
152	3-919-684-01	SCREW, AZIMUTH ADJUSTMENT		165	3-917-141-01	SPRING, COMPRESSION	
* 153	X-3367-584-2	SLIDER (HEAD) ASSY		166	X-3371-305-1	REEL (T) ASSY	
154	3-908-556-01	SPRING, HEAD TOGGLE		167	3-669-465-01	WASHER (1.5), STOPPER	
155	3-908-558-02	FITTING BLOCK, HEAD		168	X-3370-173-1	TU ASSY	
156	3-908-557-02	ROTARY BLOCK, HEAD		169	3-911-116-21	RIVET, PUSH	
* 157	3-908-559-01	STOPPER, AZIMUTH		* 171	A-2007-129-A	MD BOARD, COMPLETE (WE405)	
158	3-908-555-01	SLIDER (REV SLIDER)		* 171	A-2007-483-A	MD BOARD, COMPLETE (WR350Z/WR661)	
159	3-917-143-11	SPRING, TENSION		172	3-930-972-01	DETENT, HALF	
160	3-388-848-01	SCREW (P2X6) (B TIGHT)		173	3-917-142-01	SPRING, COMPRESSION	
161	3-911-113-01	SPRING, TENSION		HP101	1-500-093-11	HEAD, MAGNETIC (PLAYBACK)	
162	X-3370-643-1	PINCH LEVER (REV) ASSY		HRPE101	1-500-094-11	HEAD, MAGNETIC (REC/PB/ERASE)	
163	X-3367-588-1	PINCH LEVER (FWD) ASSY					

5-5. TC MECHANISM SECTION 3
(WE405: TCM-220WR1
WR350Z, WR661: TCM-220WR4E)

●H: MOTOR BOARD
 (Supplied with MD board)

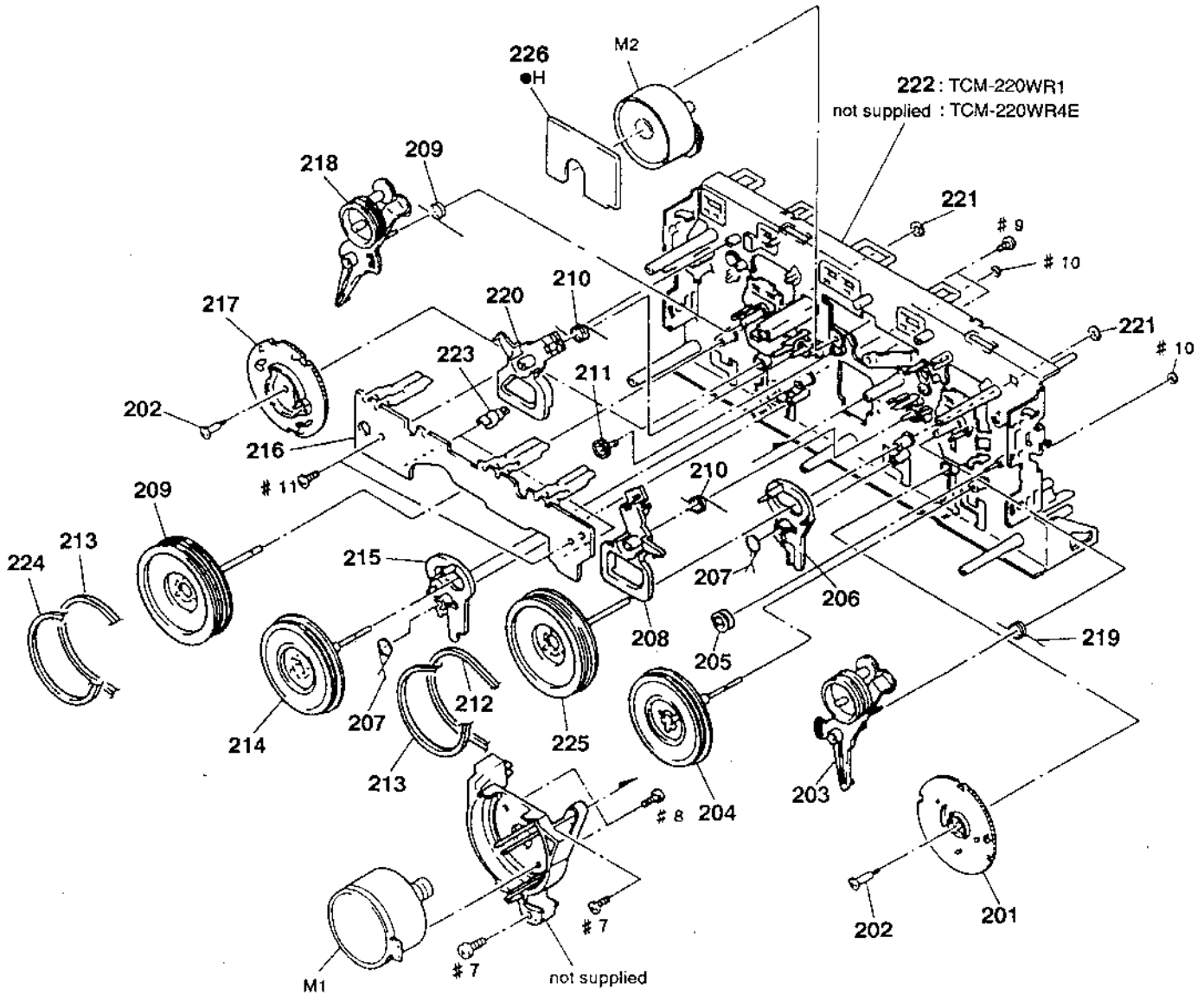

Ref. No.	Part No.	Description	Remark	Ref. No.	Part No.	Description	Remark
201	3-908-597-01	CAM (A)		* 216	1-650-669-11	LEAF SWITCH BOARD	
202	3-908-608-11	SCREW, STEP		217	3-908-598-01	CAM (B)	
203	X-3367-590-2	ARM (A) ASSY, FR		218	X-3369-849-2	ARM (B) ASSY, FR	
204	X-3370-169-1	FLYWHEEL (AR) ASSY		219	3-914-111-01	SPRING (FR), TORSION	
205	3-928-047-01	PULLEY, TENSION		220	3-908-604-01	LEVER (TRIGGER B)	
206	3-908-599-01	LEVER (REV-A)		221	3-911-115-01	WASHER, STOPPER	
207	3-908-601-01	SPRING (REV LEVER), TORSION		222	X-3371-441-1	CHASSIS ASSY, MECHANICAL (TCM-220WR1)	
208	3-908-603-01	LEVER (TRIGGER A)		224	3-917-176-11	BELT (B)	
209	X-3370-170-1	FLYWHEEL (BF) ASSY		225	X-3370-172-1	FLYWHEEL (AF) ASSY	
210	3-908-605-01	SPRING (TRIGGER), TORSION		* 226	A-2007-129-A	MD BOARD, COMPLETE (WE405)	
211	3-908-609-01	GEAR, TRIGGER		* 226	A-2007-483-A	MD BOARD, COMPLETE (WR350Z/WR661)	
212	3-913-845-11	BELT (A)		M1	X-3371-223-1	MOTOR ASSY (CAPSTAN)	
213	3-913-846-11	BELT (FR)		M2	A-2004-410-A	MOTOR ASSY, DC (TRIGGER)	
214	X-3370-171-1	FLYWHEEL (BR) ASSY					
215	3-908-600-01	LEVER (REV-B)					

LEAF SWITCH

MAIN

SECTION 6

ELECTRICAL PARTS LIST

NOTE:

The components identified by mark Δ or dotted line with mark Δ are critical for safety. Replace only with part number specified.

Les composants identifiés par une marque Δ sont critiques pour la sécurité. Ne les remplacer que par une pièce portant le numéro spécifié.

When indicating parts by reference number, please include the board name.

- Due to standardization, replacements in the parts list may be different from the parts specified in the diagrams or the components used on the set.
- Items marked "*" are not stocked since they are seldom required for routine service. Some delay should be anticipated when ordering these items.
- RESISTORS
All resistors are in ohms
METAL: Metal-film resistor
F: nonflammable
- SEMICONDUCTORS
In each case, u: μ , for example:
uA...: μ A..., uPA...: μ PA..., uPB...: μ PB...,
uPC...: μ PC..., uPD...: μ PD...

- CAPACITORS
uF: μ F
- COILS
uH: μ H
- Abbreviation
CND : Canadian model
G : German model
IT : Italian model
SP : Singapore model
MY : Malaysia model
AUS : Australian model
CHI : Chinese model

Ref. No.	Part No.	Description	Remark	Ref. No.	Part No.	Description	Remark
*	1-650-669-11	LEAF SWITCH BOARD *****		*	A-2007-484-A	MAIN BOARD, COMPLETE ***** (WR350Z/WR661:US, CND)	
		< CONNECTOR >					
* CN1001	1-568-854-11	SOCKET, CONNECTOR 11P < TRANSISTOR >		*	A-2007-486-A	MAIN BOARD, COMPLETE ***** (WR661:AEP, UK, G, IT)	
Q1001	8-749-010-90	TRANSISTOR PHOTO REFLECTOR NJL5165KA-HZ		*	A-2007-487-A	MAIN BOARD, COMPLETE (WR661:B) *****	
Q1002	8-749-010-90	TRANSISTOR PHOTO REFLECTOR NJL5165KA-HZ < RESISTOR >		*	A-2007-488-A	MAIN BOARD, COMPLETE ***** (WE405:AEP, UK, G, CH, MY, SP)	
R1001	1-249-412-11	CARBON 390 5% 1/4W F		*	A-2007-489-A	MAIN BOARD, COMPLETE (WE405:E) *****	
R1002	1-249-412-11	CARBON 390 5% 1/4W F		*	A-2007-490-A	MAIN BOARD, COMPLETE (WE405:AUS) *****	
R1003	1-249-414-11	CARBON 560 5% 1/4W F		*	A-2007-546-A	MAIN BOARD, COMPLETE (WE405:US, CND) *****	
R1004	1-247-834-11	CARBON 1.3K 5% 1/4W				MAIN (A) BOARD	
R1005	1-247-818-11	CARBON 300 5% 1/4W < SWITCH >				MAIN (B) BOARD	
S1001	1-692-832-11	SWITCH, PUSH (1 KEY) (A PLAY)				MAIN (C) BOARD	
S1002	1-692-832-11	SWITCH, PUSH (1 KEY) (B PLAY)				MAIN (D) BOARD	
S1003	1-572-248-11	SWITCH, LEAF (A HALF)				MAIN (E) BOARD (US, CND, E, AUS)	
S1004	1-571-281-21	SWITCH, LEAF (A CrO2)				MAIN (F) BOARD (EXCEPT US, CND, E, AUS)	
S1005	1-571-281-21	SWITCH, LEAF (REC A)				MAIN (G) BOARD *****	
S1006	1-572-248-11	SWITCH, LEAF (B HALF)					
S1007	1-571-281-21	SWITCH, LEAF (B METAL)					
S1008	1-571-281-21	SWITCH, LEAF (B CrO2)					
S1009	1-571-281-21	SWITCH, LEAF (REC B)		*	3-931-428-01	HOLDER (FL) < CAPACITOR >	

				C102	1-124-925-11	ELECT 2.2uF 20% 100V	
				C103	1-126-963-11	ELECT 4.7uF 20% 50V	
				C104	1-102-122-21	CERAMIC 0.0027uF 10% 50V	
							(WR350Z/WR661)
				C104	1-162-302-11	CERAMIC 0.0022uF 20% 16V (WE405)	
				C106	1-126-964-11	ELECT 10uF 20% 50V	
				C107	1-137-399-11	FILM 0.1uF 5% 50V	
				C108	1-137-375-11	FILM 0.068uF 5% 50V	
				C109	1-126-963-11	ELECT 4.7uF 20% 50V	
				C110	1-124-902-00	ELECT 0.47uF 20% 50V	
				C111	1-126-963-11	ELECT 4.7uF 20% 50V	

Ref.No.	Part No.	Description	Remark	Ref.No.	Part No.	Description	Remark
C112	1-126-963-11	ELECT	4.7uF 20% 50V	C810	1-161-494-00	CERAMIC	0.022uF 25V
C113	1-124-925-11	ELECT	2.2uF 20% 100V	C811	1-126-935-11	ELECT	470uF 20% 6.3V
C114	1-126-963-11	ELECT	4.7uF 20% 50V	C812	1-164-159-11	CERAMIC	0.1uF 50V
C115	1-162-294-31	CERAMIC	0.001uF 10% 50V (WE405:AEP, UK, G, IT, CH, MY, SP)	C813	1-137-446-11	FILM	0.18uF 5% 50V
C117	1-162-306-11	CERAMIC	0.01uF 20% 16V	C814	1-136-175-00	FILM	0.68uF 5% 50V
C202	1-124-925-11	ELECT	2.2uF 20% 100V	C815	1-137-370-11	FILM	0.01uF 5% 50V
C203	1-126-963-11	ELECT	4.7uF 20% 50V	C816	1-164-159-11	CERAMIC	0.1uF 50V
C204	1-102-122-21	CERAMIC	0.0027uF 10% 50V (WR350Z/WR661)	C817	1-161-494-00	CERAMIC	0.022uF 25V
C204	1-162-302-11	CERAMIC	0.0022uF 20% 16V (WE405)	C818	1-126-952-11	ELECT	1000uF 20% 16V
C206	1-126-964-11	ELECT	10uF 20% 50V	C819	1-126-963-11	ELECT	4.7uF 20% 50V
C207	1-137-399-11	FILM	0.1uF 5% 50V	C901	1-126-967-11	ELECT	47uF 20% 10V
C208	1-137-375-11	FILM	0.068uF 5% 50V	< CONNECTOR >			
C209	1-126-963-11	ELECT	4.7uF 20% 50V	* CN702	1-580-230-31	PIN, CONNECTOR (PC BOARD) 2P	
C210	1-124-902-00	ELECT	0.47uF 20% 50V	CN703	1-568-106-11	PIN, CONNECTOR 4P (WE405:E/WR661:E)	
C211	1-126-963-11	ELECT	4.7uF 20% 50V	CN705	1-568-226-11	PIN, CONNECTOR 2P (WE405:AEP, UK, G, IT, CH, MY, SP/WR661:AEP, UK, G, IT)	
C212	1-126-963-11	ELECT	4.7uF 20% 50V	CNA501	1-506-468-11	PIN, CONNECTOR 3P (WE405)	
C213	1-124-925-11	ELECT	2.2uF 20% 100V	* CNA808	1-568-954-11	PIN, CONNECTOR 5P (WE405:US, CND, E, AUS/WR350Z/WR661:US, CND, E)	
C214	1-126-963-11	ELECT	4.7uF 20% 50V	* CNF802	1-568-845-11	SOCKET, CONNECTOR 31P	
C215	1-162-294-31	CERAMIC	0.001uF 10% 50V (WE405:AEP, UK, G, IT, CH, MY, SP)	CNF803	1-568-838-11	SOCKET, CONNECTOR 21P	
C217	1-162-306-11	CERAMIC	0.01uF 20% 16V	* CNF804	1-568-830-11	SOCKET, CONNECTOR 11P	
C501	1-124-903-11	ELECT	1uF 20% 50V	* CNF805	1-568-830-11	SOCKET, CONNECTOR 11P	
C502	1-126-965-11	ELECT	22uF 20% 50V	* CNF806	1-568-830-11	SOCKET, CONNECTOR 11P	
C507	1-126-964-11	ELECT	10uF 20% 50V	* CNF807	1-568-873-11	SOCKET, CONNECTOR 31P	
C508	1-126-964-11	ELECT	10uF 20% 50V	CN701	1-766-269-11	PIN, CONNECTOR (PC BOARD) 7P	
C509	1-126-964-11	ELECT	10uF 20% 50V	< DIODE >			
C512	1-104-664-11	ELECT	47uF 20% 25V	D101	8-719-933-33	DIODE	HZS6A1L
C513	1-126-935-11	ELECT	470uF 20% 16V (WR350Z/WR661)	D201	8-719-933-33	DIODE	HZS6A1L
C514	1-161-494-00	CERAMIC	0.022uF 25V (WE405)	D501	8-719-987-63	DIODE	1N4148M
C701	1-126-946-11	ELECT	6800uF 20% 25V	D701	8-719-024-99	DIODE	11ES2-NTA2B
C702	1-126-946-11	ELECT	6800uF 20% 25V	D702	8-719-024-99	DIODE	11ES2-NTA2B
C703	1-124-903-11	ELECT	1uF 20% 50V	D703	8-719-024-99	DIODE	11ES2-NTA2B
C704	1-126-968-11	ELECT	100uF 20% 50V	D704	8-719-024-99	DIODE	11ES2-NTA2B
C705	1-128-551-11	ELECT	22uF 20% 25V	D705	8-719-987-63	DIODE	1N4148M
C706	1-126-927-11	ELECT	2200uF 20% 10V	D706	8-719-987-63	DIODE	1N4148M
C707	1-126-927-11	ELECT	2200uF 20% 10V	D707	8-719-024-99	DIODE	11ES2-NTA2B
C708	1-126-963-11	ELECT	4.7uF 20% 50V	D708	8-719-987-63	DIODE	1N4148M
C710	1-126-916-11	ELECT	1000uF 20% 6.3V	D709	8-719-933-33	DIODE	HZS6A1L
C711	1-126-965-11	ELECT	22uF 20% 50V	D710	8-719-000-54	DIODE	UZL-6L3
△C712	1-113-925-51	ELECT	0.01uF 20% 250V (WE405:AEP, UK, G, IT, CH, MY, SP/WR661:AEP, UK, G, IT)	D711	8-719-933-33	DIODE	HZS6A1L
C714	1-161-494-00	CERAMIC	0.022uF 25V	D712	8-719-933-38	DIODE	HZS6B3L
C801	1-162-306-11	CERAMIC	0.01uF 20% 16V	D713	8-719-987-63	DIODE	1N4148M
C802	1-162-306-11	CERAMIC	0.01uF 20% 16V	D714	8-719-987-63	DIODE	1N4148M
C806	1-164-159-11	CERAMIC	0.1uF 50V	D715	8-719-987-63	DIODE	1N4148M
C807	1-161-494-00	CERAMIC	0.022uF 25V	D716	8-719-000-78	DIODE	UZL-7L2
C808	1-161-494-00	CERAMIC	0.022uF 25V	D718	8-719-933-33	DIODE	HZS6A1L
C809	1-161-494-00	CERAMIC	0.022uF 25V	D901	8-719-313-48	DIODE	SEL6210S-TH12 (AUTO)

The components identified by mark Δ or dotted line with mark Δ are critical for safety.
Replace only with part number specified.

Les composants identifiés par une marque Δ sont critiques pour la sécurité.
Ne les remplacer que par une pièce portant le numéro spécifié.

Ref. No.	Part No.	Description	Remark	Ref. No.	Part No.	Description	Remark
< FLUORESCENT INDICATOR >				< RESISTOR >			
FLT901	1-517-491-11	INDICATOR TUBE, FLUORESCENT		R101	1-249-429-11	CARBON 10K 5% 1/4W	
< IC >				R102	1-247-887-00	CARBON 220K 5% 1/4W	
IC501	8-752-075-27	IC CXA1878Q		R103	1-249-423-11	CARBON 3.3K 5% 1/4W	F
IC502	8-759-634-51	IC M5218AP (WE405)		R104	1-247-887-00	CARBON 220K 5% 1/4W	
IC701	8-759-634-51	IC M5218AP		R105	1-247-848-11	CARBON 5.1K 5% 1/4W	
IC801	8-759-370-82	IC M38172M4-156FP		R106	1-249-420-11	CARBON 1.8K 5% 1/4W	F
IC802	8-759-634-51	IC M5218AP		R107	1-249-421-11	CARBON 2.2K 5% 1/4W	F
IC803	8-759-165-82	IC PST600E-T		R108	1-249-430-11	CARBON 12K 5% 1/4W	
IC804	8-759-822-09	IC LB1641		R109	1-249-417-11	CARBON 1K 5% 1/4W	F
IC806	8-759-000-48	IC MC14052BCP		R110	1-249-429-11	CARBON 10K 5% 1/4W	
IC901	8-741-780-51	IC SBX1780-51		R111	1-249-423-11	CARBON 3.3K 5% 1/4W	F
< JACK >				R112	1-249-417-11	CARBON 1K 5% 1/4W	F
J501	1-770-614-11	JACK, PIN 4P (LINE IN, OUT)		R113	1-249-439-11	CARBON 68K 5% 1/4W	
J502	1-750-733-11	JACK (LARGE TYPE) (PHONES) (WE405)		R114	1-249-429-11	CARBON 10K 5% 1/4W	
< FILTER >				R115	1-249-424-11	CARBON 3.9K 5% 1/4W	F
LPF101	1-235-175-11	FILTER, LOW PASS (WE405)		R116	1-249-425-11	CARBON 4.7K 5% 1/4W	F
LPF101	1-239-355-11	FILTER, LOW PASS (WR350Z/WR661)		R117	1-249-433-11	CARBON 22K 5% 1/4W	(WE405)
LPF201	1-235-175-11	FILTER, LOW PASS (WE405)		R118	1-249-437-11	CARBON 47K 5% 1/4W	(WE405)
LPF201	1-239-355-11	FILTER, LOW PASS (WR350Z/WR661)		R119	1-249-433-11	CARBON 22K 5% 1/4W	(WE405)
< TRANSISTOR >				R120	1-249-409-11	CARBON 220 5% 1/4W	F (WE405)
Q101	8-729-206-28	TRANSISTOR RN1210		R121	1-247-872-11	CARBON 51K 5% 1/4W	
Q102	8-729-142-25	TRANSISTOR 2SD1020-HFE		R201	1-249-429-11	CARBON 10K 5% 1/4W	
Q201	8-729-206-28	TRANSISTOR RN1210		R202	1-247-887-00	CARBON 220K 5% 1/4W	
Q202	8-729-142-25	TRANSISTOR 2SD1020-HFE		R203	1-249-423-11	CARBON 3.3K 5% 1/4W	F
Q501	8-729-900-65	TRANSISTOR DTA144ES		R204	1-247-887-00	CARBON 220K 5% 1/4W	
Q701	8-729-141-83	TRANSISTOR 2SB1094-LK		R205	1-247-848-11	CARBON 5.1K 5% 1/4W	
Q702	8-729-209-15	TRANSISTOR 2SD2012		R206	1-249-420-11	CARBON 1.8K 5% 1/4W	F
Q703	8-729-141-83	TRANSISTOR 2SB1094-LK		R207	1-249-421-11	CARBON 2.2K 5% 1/4W	F
Q704	8-729-620-05	TRANSISTOR 2SC2603-EF		R208	1-249-430-11	CARBON 12K 5% 1/4W	
Q705	8-729-900-80	TRANSISTOR DTC114ES (WE405:US, CND, E, AUS/WR350Z/WR661:US, CND, E)		R209	1-249-417-11	CARBON 1K 5% 1/4W	F
Q706	8-729-900-80	TRANSISTOR DTC114ES (WE405:US, CND, E, AUS/WR350Z/WR661:US, CND, E)		R210	1-249-429-11	CARBON 10K 5% 1/4W	
Q707	8-729-119-76	TRANSISTOR 2SA1175-HFE		R211	1-249-423-11	CARBON 3.3K 5% 1/4W	F
Q708	8-729-140-04	TRANSISTOR 2SB1116A-L		R212	1-249-417-11	CARBON 1K 5% 1/4W	F
Q801	8-729-206-28	TRANSISTOR RN1210 (WE405:US, CND, E, AUS/WR350Z/WR661:US, CND, E)		R213	1-249-439-11	CARBON 68K 5% 1/4W	
Q802	8-729-900-89	TRANSISTOR DTC144ES		R214	1-249-429-11	CARBON 10K 5% 1/4W	
Q803	8-729-801-93	TRANSISTOR 2SD1387		R215	1-249-424-11	CARBON 3.9K 5% 1/4W	F
Q804	8-729-900-61	TRANSISTOR DTA114ES		R216	1-249-425-11	CARBON 4.7K 5% 1/4W	F
Q805	8-729-119-76	TRANSISTOR 2SA1175-HFE		R217	1-249-433-11	CARBON 22K 5% 1/4W	(WE405)
Q806	8-729-900-89	TRANSISTOR DTC144ES		R218	1-249-437-11	CARBON 47K 5% 1/4W	(WE405)
Q807	8-729-206-28	TRANSISTOR RN1210		R219	1-249-433-11	CARBON 22K 5% 1/4W	(WE405)
Q808	8-729-119-76	TRANSISTOR 2SA1175-HFE		R220	1-249-409-11	CARBON 220 5% 1/4W	F (WE405)
				R221	1-247-872-11	CARBON 51K 5% 1/4W	
				R501	1-215-452-00	METAL 20K 1% 1/4W	
				R502	1-215-455-00	METAL 27K 1% 1/4W	
				R505	1-249-413-11	CARBON 470 5% 1/4W	F
				R506	1-249-429-11	CARBON 10K 5% 1/4W	
				R507	1-249-437-11	CARBON 47K 5% 1/4W	
				R509	1-249-417-11	CARBON 1K 5% 1/4W	F
				R510	1-247-807-31	CARBON 100 5% 1/4W	

Ref. No.	Part No.	Description	Remark	Ref. No.	Part No.	Description	Remark
R517	1-249-410-11	CARBON 270 5% 1/4W F		R826	1-249-429-11	CARBON 10K 5% 1/4W	
R520	1-249-437-11	CARBON 47K 5% 1/4W		R827	1-249-429-11	CARBON 10K 5% 1/4W	
R701	1-249-414-11	CARBON 560 5% 1/4W F		R828	1-249-431-11	CARBON 15K 5% 1/4W	
R702	1-249-429-11	CARBON 10K 5% 1/4W		R829	1-249-414-11	CARBON 560 5% 1/4W F	
		(WE405:US, CND, E, AUS/WR350Z/WR661:US, CND, E)		R830	1-249-433-11	CARBON 22K 5% 1/4W	
R704	1-249-425-11	CARBON 4.7K 5% 1/4W F		R831	1-249-433-11	CARBON 22K 5% 1/4W	
R705	1-247-852-11	CARBON 7.5K 5% 1/4W		R832	1-249-429-11	CARBON 10K 5% 1/4W	
R706	1-249-419-11	CARBON 1.5K 5% 1/4W F		R833	1-249-425-11	CARBON 4.7K 5% 1/4W F	
R707	1-249-429-11	CARBON 10K 5% 1/4W		R834	1-249-435-11	CARBON 33K 5% 1/4W (WE405)	
R708	1-249-419-11	CARBON 1.5K 5% 1/4W F		R835	1-249-432-11	CARBON 18K 5% 1/4W (WE405)	
R709	1-249-425-11	CARBON 4.7K 5% 1/4W F		R836	1-249-426-11	CARBON 5.6K 5% 1/4W (WE405)	
R710	1-249-417-11	CARBON 1K 5% 1/4W F		R837	1-249-421-11	CARBON 2.2K 5% 1/4W F	
R711	1-249-427-11	CARBON 6.8K 5% 1/4W F		R838	1-249-421-11	CARBON 2.2K 5% 1/4W F	
R712	1-249-427-11	CARBON 6.8K 5% 1/4W F		R839	1-249-421-11	CARBON 2.2K 5% 1/4W F	
R713	1-249-417-11	CARBON 1K 5% 1/4W F		R840	1-249-433-11	CARBON 22K 5% 1/4W	
R714	1-249-428-11	CARBON 8.2K 5% 1/4W F		R841	1-249-433-11	CARBON 22K 5% 1/4W	
R715	1-249-421-11	CARBON 2.2K 5% 1/4W F		R842	1-249-417-11	CARBON 1K 5% 1/4W F (WE405)	
R716	1-249-430-11	CARBON 12K 5% 1/4W		R844	1-249-429-11	CARBON 10K 5% 1/4W	
R717	1-249-421-11	CARBON 2.2K 5% 1/4W F				(WR350Z/WR661)	
R718	1-249-429-11	CARBON 10K 5% 1/4W		R845	1-249-416-11	CARBON 820 5% 1/4W F	
R719	1-249-437-11	CARBON 47K 5% 1/4W				(WR350Z/WR661)	
R720	1-249-413-11	CARBON 470 5% 1/4W F		R846	1-249-426-11	CARBON 5.6K 5% 1/4W	
						(WR350Z/WR661)	
R721	1-249-421-11	CARBON 2.2K 5% 1/4W F		R847	1-249-433-11	CARBON 22K 5% 1/4W	
△R722	1-219-137-11	FUSIBLE 0.33 10% 1/4W				(WR350Z/WR661)	
△R723	1-217-371-00	FUSIBLE 0.47 10% 1/4W		R849	1-249-441-11	CARBON 100K 5% 1/4W	
R724	1-249-409-11	CARBON 220 5% 1/4W F		R902	1-249-418-11	CARBON 1.2K 5% 1/4W F	
△R725	1-219-137-11	FUSIBLE 0.33 10% 1/4W		R903	1-249-420-11	CARBON 1.8K 5% 1/4W F	
R801	1-249-433-11	CARBON 22K 5% 1/4W		R904	1-249-422-11	CARBON 2.7K 5% 1/4W F	
R802	1-247-807-31	CARBON 100 5% 1/4W		R905	1-249-418-11	CARBON 1.2K 5% 1/4W F	
R803	1-249-429-11	CARBON 10K 5% 1/4W		R906	1-249-420-11	CARBON 1.8K 5% 1/4W F	
R804	1-249-433-11	CARBON 22K 5% 1/4W		R907	1-249-418-11	CARBON 1.2K 5% 1/4W F	
R805	1-249-433-11	CARBON 22K 5% 1/4W		R908	1-249-420-11	CARBON 1.8K 5% 1/4W F	
R806	1-247-895-00	CARBON 470K 5% 1/4W		R909	1-249-422-11	CARBON 2.7K 5% 1/4W F	
R807	1-247-895-00	CARBON 470K 5% 1/4W		R910	1-249-424-11	CARBON 3.9K 5% 1/4W F	
R808	1-249-425-11	CARBON 4.7K 5% 1/4W F		R911	1-249-427-11	CARBON 6.8K 5% 1/4W F	
R809	1-249-425-11	CARBON 4.7K 5% 1/4W F		R912	1-249-418-11	CARBON 1.2K 5% 1/4W F	
R810	1-249-425-11	CARBON 4.7K 5% 1/4W F		R913	1-249-420-11	CARBON 1.8K 5% 1/4W F	
R811	1-249-417-11	CARBON 1K 5% 1/4W F		R914	1-249-422-11	CARBON 2.7K 5% 1/4W F	
R812	1-249-436-11	CARBON 39K 5% 1/4W		R915	1-249-424-11	CARBON 3.9K 5% 1/4W F	
R813	1-249-436-11	CARBON 39K 5% 1/4W		R916	1-249-413-11	CARBON 470 5% 1/4W F	
R814	1-249-441-11	CARBON 100K 5% 1/4W		R917	1-249-422-11	CARBON 2.7K 5% 1/4W F	
R815	1-249-429-11	CARBON 10K 5% 1/4W		R918	1-249-424-11	CARBON 3.9K 5% 1/4W F	
R816	1-249-429-11	CARBON 10K 5% 1/4W		R919	1-247-807-31	CARBON 100 5% 1/4W	
R817	1-249-429-11	CARBON 10K 5% 1/4W		R920	1-249-407-11	CARBON 150 5% 1/4W F	
R818	1-249-429-11	CARBON 10K 5% 1/4W				< VARIABLE RESISTOR >	
R819	1-249-407-11	CARBON 150 5% 1/4W F		RV101	1-241-630-11	RES, ADJ, CARBON 10K	
R820	1-249-437-11	CARBON 47K 5% 1/4W		RV201	1-241-630-11	RES, ADJ, CARBON 10K	
R821	1-249-437-11	CARBON 47K 5% 1/4W		RV501	1-241-797-11	RES, VAR, CARBON 20K (REC LEVEL)	
R822	1-249-437-11	CARBON 47K 5% 1/4W					
R825	1-249-418-11	CARBON 1.2K 5% 1/4W F					

The components identified by mark △ or dotted line with mark △ are critical for safety. Replace only with part number specified.	Les composants identifiés par une marque △ sont critiques pour la sécurité. Ne les remplacer que par une pièce portant le numéro spécifié.
--	--

Ref. No.	Part No.	Description	Remark
< SWITCH >			
△S701	1-762-581-11	SWITCH, AC POWER PUSH (1 KEY) (POWER) (WE405:AEP, UK, G, IT, CH, MY, SP/WR661:AEP, UK, G, IT)	
△S901	1-762-580-11	SWITCH, PUSH (1 KEY) (POWER) (WE405:US, CND, E, AUS/WR350Z/WR661:US, CND, E)	
S902	1-762-567-11	SWITCH, SLIDE (DIRECTION)	
S903	1-762-567-11	SWITCH, SLIDE (DOLBY NR)	
S904	1-554-303-21	SWITCH, TACTILE (■ DECK A)	
S905	1-554-303-21	SWITCH, TACTILE (▷ DECK A)	
S906	1-554-303-21	SWITCH, TACTILE (◁ DECK A)	
S907	1-554-303-21	SWITCH, TACTILE (DECK A, COUNTER RESET)	
S908	1-554-303-21	SWITCH, TACTILE (◀◀ DECK A)	
S909	1-554-303-21	SWITCH, TACTILE (▶▶ DECK A)	
S910	1-554-303-21	SWITCH, TACTILE (DECK B, COUNTER RESET)	
S911	1-554-303-21	SWITCH, TACTILE (◀◀ DECK B)	
S912	1-554-303-21	SWITCH, TACTILE (▶▶ DECK B)	
S913	1-554-303-21	SWITCH, TACTILE (REC ● DECK B)	
S914	1-554-303-21	SWITCH, TACTILE (PAUSE ■ DECK B)	
S915	1-554-303-21	SWITCH, TACTILE (REC MUTE ● DECK B)	
S916	1-554-303-21	SWITCH, TACTILE (HIGH/NORMAL DECK B)	
S917	1-554-303-21	SWITCH, TACTILE (■ DECK B)	
S918	1-554-303-21	SWITCH, TACTILE (▷ DECK B)	
S919	1-554-303-21	SWITCH, TACTILE (◁ DECK B)	
S920	1-554-303-21	SWITCH, TACTILE (ARL)	
S921	1-554-303-21	SWITCH, TACTILE (FADER)	
< TRANSFORMER >			
△T901	1-429-387-11	TRANSFORMER, POWER (WE405:US, CND/WR350Z/WR661:US, CND)	
△T901	1-429-388-11	TRANSFORMER, POWER (WE405:AEP, UK, G, AUS, CH, MY, SP/WR661:AEP, UK, G, IT)	
△T901	1-429-389-11	TRANSFORMER, POWER (WE405:E/WR661:E)	
< TEST PIN >			
* TP801	1-560-060-00	PIN, CONNECTOR 2P	
< VIBRATOR >			
X801	1-577-358-21	VIBRATOR, CERAMIC (4MHz)	

A-2007-129-A MD BOARD, COMPLETE (WE405)			

(including MOTOR board)			
< CAPACITOR >			
C301	1-162-289-31	CERAMIC	390PF 10% 50V
C303	1-162-282-31	CERAMIC	100PF 10% 50V
C304	1-130-487-00	MYLAR	0.022uF 5% 50V
C305	1-124-234-00	ELECT	22uF 20% 16V
C311	1-162-289-31	CERAMIC	390PF 10% 50V

Ref. No.	Part No.	Description	Remark
C313	1-162-282-31	CERAMIC	100PF 10% 50V
C314	1-130-487-00	MYLAR	0.022uF 5% 50V
C315	1-126-233-11	ELECT	22uF 20% 50V
C331	1-107-609-11	CERAMIC	75PF 5% 500V
C332	1-162-288-31	CERAMIC	330PF 10% 50V
C341	1-161-494-00	CERAMIC	0.022uF 25V
C342	1-136-165-00	FILM	0.1uF 5% 50V
C343	1-162-306-11	CERAMIC	0.01uF 20% 16V
C344	1-130-472-00	MYLAR	0.0012uF 5% 50V
C345	1-102-973-00	CERAMIC	100PF 5% 50V
C346	1-136-356-11	FILM	470PF 5% 100V
C401	1-162-289-31	CERAMIC	390PF 10% 50V
C403	1-162-282-31	CERAMIC	100PF 10% 50V
C404	1-130-487-00	MYLAR	0.022uF 5% 50V
C405	1-124-234-00	ELECT	22uF 20% 16V
C411	1-162-289-31	CERAMIC	390PF 10% 50V
C413	1-162-282-31	CERAMIC	100PF 10% 50V
C414	1-130-487-00	MYLAR	0.022uF 5% 50V
C415	1-126-233-11	ELECT	22uF 20% 50V
C431	1-107-609-11	CERAMIC	75PF 5% 500V
C432	1-162-288-31	CERAMIC	330PF 10% 50V
C441	1-161-494-00	CERAMIC	0.022uF 25V
C442	1-136-165-00	FILM	0.1uF 5% 50V
C443	1-162-306-11	CERAMIC	0.01uF 20% 16V
C444	1-130-472-00	MYLAR	0.0012uF 5% 50V
C445	1-102-973-00	CERAMIC	100PF 5% 50V
C446	1-136-356-11	FILM	470PF 5% 100V
C601	1-124-907-11	ELECT	10uF 20% 50V
C602	1-124-907-11	ELECT	10uF 20% 50V
C611	1-124-907-11	ELECT	10uF 20% 50V
C612	1-124-907-11	ELECT	10uF 20% 50V
C621	1-136-293-11	FILM	0.0082uF 5% 100V
C622	1-136-173-00	FILM	0.47uF 5% 50V
C623	1-130-299-00	FILM	0.012uF 5% 50V
C624	1-137-436-11	FILM	0.0039uF 5% 50V
C625	1-137-436-11	FILM	0.0039uF 5% 50V
C641	1-126-233-11	ELECT	22uF 20% 50V
C642	1-104-664-11	ELECT	47uF 20% 16V
C643	1-124-465-00	ELECT	0.47uF 20% 50V
C644	1-107-584-11	CERAMIC	4PF 0.25PF 500V
C651	1-161-494-00	CERAMIC	0.022uF 25V
< CONNECTOR >			
* CN601	1-568-864-11	SOCKET, CONNECTOR 21P	
* CN651	1-564-521-11	PLUG, CONNECTOR 8P	
< DIODE >			
D601	8-719-987-63	DIODE 1N4148M	

The components identified by mark △ or dotted line with mark △ are critical for safety. Replace only with part number specified.	Les composants identifiés par une marque △ sont critiques pour la sécurité. Ne les remplacer que par une pièce portant le numéro spécifié.
--	--

Ref. No.	Part No.	Description	Remark	Ref. No.	Part No.	Description	Remark
< IC >				< VARIABLE RESISTOR >			
IC601	8-759-710-59	IC NJM4580D-D		△R621	1-212-851-00	FUSIBLE 5.6 5% 1/4W F	
IC611	8-759-710-59	IC NJM4580D-D		△R622	1-212-851-00	FUSIBLE 5.6 5% 1/4W F	
IC641	8-759-106-56	IC uPC1297CA		R623	1-249-440-11	CARBON 82K 5% 1/4W	
< COIL >				R624	1-249-440-11	CARBON 82K 5% 1/4W	
L331	1-410-780-11	INDUCTOR 27mH		R625	1-249-429-11	CARBON 10K 5% 1/4W	
L431	1-410-780-11	INDUCTOR 27mH		R626	1-249-429-11	CARBON 10K 5% 1/4W	
< MOTOR >				R651	1-247-856-00	CARBON 11K 5% 1/4W	
M2	A-2004-410-A	MOTOR ASSY, DC (TRIGGER)		R652	1-247-856-00	CARBON 11K 5% 1/4W	
< TRANSISTOR >				R653	1-249-441-11	CARBON 100K 5% 1/4W	
Q621	8-729-194-57	TRANSISTOR 2SC945-P		< RELAY >			
Q622	8-729-194-57	TRANSISTOR 2SC945-P		RY601	1-515-913-11	RELAY	
Q623	8-729-119-76	TRANSISTOR 2SA1175-HFE		< TRANSFORMER >			
Q651	8-729-900-65	TRANSISTOR DTA144ES		T341	1-433-381-11	TRANSFORMER, BIAS OSCILLATOR	
< RESISTOR >				T441	1-433-381-11	TRANSFORMER, BIAS OSCILLATOR	
R301	1-247-881-00	CARBON 120K 5% 1/4W		T621	1-429-222-11	TRANSFORMER, BIAS OSCILLATION	
R302	1-247-807-31	CARBON 100 5% 1/4W		< TEST PIN >			
R304	1-247-882-11	CARBON 130K 5% 1/4W		* TP341	1-568-449-11	HOUSING, CONNECTOR (PC BOARD) 3P	
R305	1-247-850-11	CARBON 6.2K 5% 1/4W		*****			
R311	1-247-881-00	CARBON 120K 5% 1/4W		* A-2007-483-A	MD BOARD, COMPLETE (WR350Z/WR661)		
R312	1-247-807-31	CARBON 100 5% 1/4W		*****			
R314	1-247-882-11	CARBON 130K 5% 1/4W		(including MOTOR board)			
R315	1-247-850-11	CARBON 6.2K 5% 1/4W		MOTOR BOARD			
R331	1-249-430-11	CARBON 12K 5% 1/4W		< CAPACITOR >			
R341	1-249-429-11	CARBON 10K 5% 1/4W		C301	1-162-289-31	CERAMIC 390PF 10% 50V	
R342	1-249-435-11	CARBON 33K 5% 1/4W		C302	1-126-968-11	ELECT 100uF 20% 6.3V	
R343	1-247-883-00	CARBON 150K 5% 1/4W		C303	1-162-282-31	CERAMIC 100PF 10% 50V	
△R344	1-212-857-00	FUSIBLE 10 5% 1/4W F		C304	1-130-483-00	MYLAR 0.01uF 5% 50V	
R401	1-247-881-00	CARBON 120K 5% 1/4W		C305	1-107-715-11	ELECT 22uF 20% 16V	
R402	1-247-807-31	CARBON 100 5% 1/4W		C311	1-162-289-31	CERAMIC 390PF 10% 50V	
R404	1-247-882-11	CARBON 130K 5% 1/4W		C313	1-162-282-31	CERAMIC 100PF 10% 50V	
R405	1-247-850-11	CARBON 6.2K 5% 1/4W		C314	1-130-487-00	MYLAR 0.022uF 5% 50V	
R411	1-247-881-00	CARBON 120K 5% 1/4W		C315	1-126-233-11	ELECT 22uF 20% 50V	
R412	1-247-807-31	CARBON 100 5% 1/4W		C331	1-136-434-11	FILM 120PF 5% 630V	
R414	1-247-882-11	CARBON 130K 5% 1/4W		C332	1-162-288-31	CERAMIC 330PF 10% 50V	
R415	1-247-850-11	CARBON 6.2K 5% 1/4W		*****			
R431	1-249-430-11	CARBON 12K 5% 1/4W		The components identified by mark			
R441	1-249-429-11	CARBON 10K 5% 1/4W		△ or dotted line with mark △ are			
R442	1-249-435-11	CARBON 33K 5% 1/4W		critical for safety.			
R443	1-247-883-00	CARBON 150K 5% 1/4W		Replace only with part number			
△R444	1-212-857-00	FUSIBLE 10 5% 1/4W F		specified.			
R601	1-249-409-11	CARBON 220 5% 1/4W F		Les composants identifiés par une			
R602	1-249-409-11	CARBON 220 5% 1/4W F		marque △ sont critiques pour la			
R611	1-249-409-11	CARBON 220 5% 1/4W F		sécurité.			
R612	1-249-409-11	CARBON 220 5% 1/4W F		Ne les remplacer que par une pièce			
				portant le numéro spécifié.			

<p>The components identified by mark △ or dotted line with mark △ are critical for safety. Replace only with part number specified.</p>	<p>Les composants identifiés par une marque △ sont critiques pour la sécurité. Ne les remplacer que par une pièce portant le numéro spécifié.</p>
---	---

Ref. No.	Part No.	Description	Remark	Ref. No.	Part No.	Description	Remark
C333	1-162-217-31	CERAMIC	56PF 5% 50V			< RESISTOR >	
C334	1-162-217-31	CERAMIC	56PF 5% 50V				
C401	1-162-289-31	CERAMIC	390PF 10% 50V	R301	1-247-881-00	CARBON 120K 5% 1/4W	
C402	1-126-968-11	ELECT	100uF 20% 6.3V	R302	1-249-409-11	CARBON 220 5% 1/4W	F
C403	1-162-282-31	CERAMIC	100PF 10% 50V	R303	1-249-433-11	CARBON 22K 5% 1/4W	
C404	1-130-483-00	MYLAR	0.01uF 5% 50V	R304	1-247-889-00	CARBON 270K 5% 1/4W	
C411	1-162-289-31	CERAMIC	390PF 10% 50V	R305	1-247-858-11	CARBON 13K 5% 1/4W	
C413	1-162-282-31	CERAMIC	100PF 10% 50V	R311	1-247-881-00	CARBON 120K 5% 1/4W	
C414	1-130-487-00	MYLAR	0.022uF 5% 50V	R312	1-247-807-31	CARBON 100 5% 1/4W	
C415	1-126-233-11	ELECT	22uF 20% 50V	R314	1-247-882-11	CARBON 130K 5% 1/4W	
C431	1-136-434-11	FILM	120PF 5% 630V	R315	1-247-850-11	CARBON 6.2K 5% 1/4W	
C432	1-162-288-31	CERAMIC	330PF 10% 50V	R331	1-249-430-11	CARBON 12K 5% 1/4W	
C433	1-162-217-31	CERAMIC	56PF 5% 50V	R401	1-247-881-00	CARBON 120K 5% 1/4W	
C434	1-162-217-31	CERAMIC	56PF 5% 50V	R402	1-249-409-11	CARBON 220 5% 1/4W	F
C601	1-126-157-11	ELECT	10uF 20% 16V	R403	1-249-433-11	CARBON 22K 5% 1/4W	
C602	1-126-157-11	ELECT	10uF 20% 16V	R404	1-247-889-00	CARBON 270K 5% 1/4W	
C611	1-124-907-11	ELECT	10uF 20% 50V	R405	1-247-858-11	CARBON 13K 5% 1/4W	
C612	1-124-907-11	ELECT	10uF 20% 50V	R411	1-247-881-00	CARBON 120K 5% 1/4W	
C621	1-137-150-11	FILM	0.01uF 5% 100V	R412	1-247-807-31	CARBON 100 5% 1/4W	
C622	1-126-961-11	ELECT	2.2uF 20% 50V	R414	1-247-882-11	CARBON 130K 5% 1/4W	
C623	1-136-155-00	FILM	0.015uF 5% 50V	R415	1-247-850-11	CARBON 6.2K 5% 1/4W	
C624	1-130-481-00	MYLAR	0.0068uF 5% 50V	R431	1-249-430-11	CARBON 12K 5% 1/4W	
C625	1-130-481-00	MYLAR	0.0068uF 5% 50V	R601	1-249-409-11	CARBON 220 5% 1/4W	F
C627	1-124-903-11	ELECT	1uF 20% 50V	R602	1-249-409-11	CARBON 220 5% 1/4W	F
C628	1-136-153-00	FILM	0.01uF 5% 50V	R608	1-249-409-11	CARBON 220 5% 1/4W	F
C642	1-104-664-11	ELECT	47uF 20% 16V	R609	1-249-433-11	CARBON 22K 5% 1/4W	
C651	1-161-494-00	CERAMIC	0.022uF 25V	R611	1-249-409-11	CARBON 220 5% 1/4W	F
		< CONNECTOR >		R612	1-249-409-11	CARBON 220 5% 1/4W	F
* CN601	1-568-864-11	SOCKET, CONNECTOR 21P		△R621	1-212-851-00	FUSIBLE 5.6 5% 1/4W	F
* CN651	1-564-521-11	PLUG, CONNECTOR 6P		△R622	1-212-851-00	FUSIBLE 5.6 5% 1/4W	F
		< IC >		R623	1-249-432-11	CARBON 18K 5% 1/4W	
IC601	8-759-710-59	IC NJM4580D-D		R624	1-249-432-11	CARBON 18K 5% 1/4W	
IC602	8-759-143-54	IC uPC1330HA		R625	1-249-429-11	CARBON 10K 5% 1/4W	
IC611	8-759-710-59	IC NJM4580D-D		R651	1-247-856-00	CARBON 11K 5% 1/4W	
		< COIL >		R652	1-247-856-00	CARBON 11K 5% 1/4W	
L331	1-410-780-11	INDUCTOR 27mH		R653	1-249-441-11	CARBON 100K 5% 1/4W	
L431	1-410-780-11	INDUCTOR 27mH				< VARIABLE RESISTOR >	
		< MOTOR >		RV301	1-238-598-11	RES, ADJ, CARBON 2.2K	
M2	A-2004-410-A	MOTOR ASSY, DC (TRIGGER)		RV311	1-238-598-11	RES, ADJ, CARBON 2.2K	
		< TRANSISTOR >		RV341	1-238-551-11	RES, ADJ, CARBON 220K	
Q621	8-729-142-46	TRANSISTOR 2SC2001-LK		RV401	1-238-598-11	RES, ADJ, CARBON 2.2K	
Q622	8-729-142-46	TRANSISTOR 2SC2001-LK		RV411	1-238-598-11	RES, ADJ, CARBON 2.2K	
Q623	8-729-801-93	TRANSISTOR 2SD1387		RV441	1-238-551-11	RES, ADJ, CARBON 220K	
Q651	8-729-900-85	TRANSISTOR DTA144ES		RV651	1-238-599-11	RES, ADJ, CARBON 4.7K	
		< TRANSFORMER >		RV652	1-238-599-11	RES, ADJ, CARBON 4.7K	
				T621	1-423-980-11	TRANSFORMER, BIAS OSCILLATION	

The components identified by mark Δ or dotted line with mark Δ are critical for safety. Replace only with part number specified.	Les composants identifiés par une marque Δ sont critiques pour la sécurité. Ne les remplacer que par une pièce portant le numéro spécifié.
--	---

Ref. No.	Part No.	Description	Remark	Ref. No.	Part No.	Description	Remark
		MISCELLANEOUS *****				***** HARDWARE LIST *****	
△7	1-558-945-21	CORD, POWER (POLAR. SPT-1) (WE405:US, CND, E/WR350Z/WR661:US, CND)		#1	7-682-548-04	SCREW +BVTT 3X8 (S)	
△7	1-575-651-21	CORD, POWER (WE405:AEP, CH, MY, SP, G/WR661:AEP, G, IT)		#2	7-685-871-01	SCREW +BVTT 3X6 (S)	
△7	1-696-027-11	CORD, POWER (WE405:E/WR661:E)		#3	7-685-646-79	SCREW +BVTP 3X8 TYPE2 N-S	
△7	1-696-845-11	CORD, POWER (WE405:AUS)		#4	7-685-134-19	SCREW (+ PTPWH) (2. 6X8) (WE405/WR350Z)	
△7	1-751-523-11	CORD, POWER (WE405:UK)		#5	7-621-770-67	SCREW +BVTT 2. 6X6 (S)	
△7	1-769-639-11	CORD, POWER (WR661:UK)		#6	7-685-131-19	SCREW +BTP 2. 6X4 TYPE2 N-S	
△8	1-569-007-11	ADAPTER, CONVERSION 2P (WE405:E/WR661:E)		#7	7-685-534-19	SCREW +BTP 2. 6X8 TYPE2 N-S	
67	1-773-332-11	WIRE (FLAT TYPE) (31 CORE)		#8	7-621-775-10	SCREW +B 2. 6X4	
68	1-769-950-11	WIRE (FLAT TYPE) (11 CORE)		#9	7-621-775-00	SCREW +B 2. 6X3	
69	1-773-153-11	WIRE (FLAT TYPE) (21 CORE)		#10	7-623-921-01	RING, RETAINING, CAPSTAN	
		FLT901 1-517-491-11 INDICATOR TUBE, FLUORESCENT		#11	7-685-533-19	SCREW +BTP 2. 6X6 TYPE2 N-S	
		HP101 1-500-093-11 HEAD, MAGNETIC (PLAYBACK)					
		HRPE1011-500-094-11 HEAD, MAGNETIC (REC/PB/ERASE)					
		M1 X-3371-223-1 MOTOR ASSY (CAPSTAN)					
		M2 A-2004-410-A MOTOR ASSY, DC (TRIGGER)					
△T901	429-387-11	TRANSFORMER, POWER (WE405:US, CND/WR350Z/WR661:US, CND)					
△T901	429-388-11	TRANSFORMER, POWER (WE405:AEP, CH, MY, SP, UK, G, AUS/WR661:AEP, UK, G, IT)					
△T901	429-389-11	TRANSFORMER, POWER (WE405:E/WR661:E)					
△VS901	692-155-11	SELECTOR, POWER VOLTAGE (WE405:E/WR661:E)					

ACCESSORIES & PACKING MATERIALS *****							
		1-551-734-11 CORD, CONNECTION (158cm AUDIO)					
		3-810-312-11 MANUAL, INSTRUCTION (ENGLISH) (WE405:US, CND, UK, AUS/WR350Z/WR661:US, CND)					
		3-810-312-21 MANUAL, INSTRUCTION (FRENCH) (CND)					
		3-810-312-31 MANUAL, INSTRUCTION (ENGLISH, FRENCH, SPANISH, PORTUGUESE) (WE405:AEP, CH, MY, SP, E)					
		3-810-312-41 MANUAL, INSTRUCTION (GERMAN, DUTCH, SWEDISH, ITALIAN) (WE405:AEP, CH, MY, SP)					
		3-810-312-51 MANUAL, INSTRUCTION (GERMAN) (WE405:G)					
		3-810-312-61 MANUAL, INSTRUCTION (CHINESE) (WE405:E)					
		3-810-312-71 MANUAL, INSTRUCTION (ARABIC) (WR661:E)					
*		3-932-083-01 CUSHION					
*		3-932-085-01 INDIVIDUAL CARTON (WE405/WR350Z:CND)					
*		3-932-086-01 INDIVIDUAL CARTON (WR661:AEP, UK, G, IT)					
*		3-932-087-01 INDIVIDUAL CARTON (WR350Z:US)					
*		3-934-928-01 INDIVIDUAL CARTON (WR661:US, CND)					

The components identified by mark △ or dotted line with mark △ are critical for safety. Replace only with part number specified.	Les composants identifiés par une marque △ sont critiques pour la sécurité. Ne les remplacer que par une pièce portant le numéro spécifié.
---	---

TC-WE405/WR350Z/WR661

SONY SERVICE MANUAL

US Model
Canadian Model
TC-WE405/WR350Z/WR661
AEP Model
UK Model
E Model
Australian Model
TC-WE405/WR661
Chinese Model
TC-WE405

SUPPLEMENT-1

File this supplement with the service manual.

**Subject : 1. CORRECTION
2. MODEL ADDITION (TC-WR661 : Singapore, Australian model)
3. PARTS CHANGE**

(ECN-TC600191)

- The suffix of MAIN board has changed from suffix-**[11]** to **[12]**. The large change cannot be find with this change, so it is not notified.
The common changes of suffix-**[11]** and **[12]** are notified in this supplement.

MODEL IDENTIFICATION

— BACK PANEL —



TC-WE405

MODEL	PARTS No.
US	3-931-433-0□
CND	3-931-433-1□
AEP, G, MY, SP, CH	3-931-433-2□
UK	3-931-433-3□
E	3-931-433-4□
AUS	3-931-433-5□

TC-WR350Z

MODEL	PARTS No.
US	3-934-887-0□
CND	3-934-887-1□

TC-WR661

MODEL	PARTS No.
US	3-931-436-0□
CND	3-931-436-1□
AEP, G, IT	3-931-436-2□
UK	3-931-436-3□
E	3-931-436-4□
AUS	3-931-436-5□
SP	3-931-436-6□

- Abbreviation
CND : Canadian model.
G : German model.
IT : Italian model.
SP : Singapore model.
MY : Malaysia model.
AUS : Australian model.
CH : Chinese model.

1. CORRECTION

- Correct your Service Manual as shown below.
- : Indicates corrected portion

Page	INCORRECT	CORRECT																		
6	<p>Torque Measurement</p> <table border="1"> <thead> <tr> <th>Torque</th> <th>Torque meter</th> <th>Meter reading</th> </tr> </thead> <tbody> <tr> <td>FWD tension</td> <td>CQ-403Q</td> <td>100g • cm or more (1.39 oz • inch or more)</td> </tr> <tr> <td>REV tension</td> <td>CQ-403R</td> <td>100g • cm or more (1.39 oz • inch or more)</td> </tr> </tbody> </table>	Torque	Torque meter	Meter reading	FWD tension	CQ-403Q	100g • cm or more (1.39 oz • inch or more)	REV tension	CQ-403R	100g • cm or more (1.39 oz • inch or more)	<p>Torque Measurement</p> <table border="1"> <thead> <tr> <th>Torque</th> <th>Torque meter</th> <th>Meter reading</th> </tr> </thead> <tbody> <tr> <td>FWD tension</td> <td>CQ-403Q</td> <td>100g or more (3.53 oz or more)</td> </tr> <tr> <td>REV tension</td> <td>CQ-403R</td> <td>100g or more (3.53 oz or more)</td> </tr> </tbody> </table>	Torque	Torque meter	Meter reading	FWD tension	CQ-403Q	100g or more (3.53 oz or more)	REV tension	CQ-403R	100g or more (3.53 oz or more)
Torque	Torque meter	Meter reading																		
FWD tension	CQ-403Q	100g • cm or more (1.39 oz • inch or more)																		
REV tension	CQ-403R	100g • cm or more (1.39 oz • inch or more)																		
Torque	Torque meter	Meter reading																		
FWD tension	CQ-403Q	100g or more (3.53 oz or more)																		
REV tension	CQ-403R	100g or more (3.53 oz or more)																		
29	<p>Ref. No Part No Description Remark</p> <p>*** EXPLODED VIEWS ***</p> <p>11 4-977-358-01 CUSHION (8X12.5) (WE405/WR350Z)</p> <p>▲T901 429-387-11 TRANSFORMER, POWER (WE405:US, CND/WR350Z/WR661:US, CND)</p> <p>▲T901 429-388-11 TRANSFORMER, POWER (WE405:AEP, CH, MY, SP, UK, G, AUS/WR661:AEP, SP, UK, G, IT)</p> <p>▲T901 429-389-11 TRANSFORMER, POWER (WE405:E/WR661:E)</p> <p>▲VS901 692-155-11 SELECTOR, POWER VOLTAGE (WE405:E/WR661:E)</p>	<p>Ref. No Part No Description Remark</p> <p>*** EXPLODED VIEWS *** not supplied</p> <p>▲T901 1-429-387-11 TRANSFORMER, POWER (WE405:US, CND/WR350Z/WR661:US, CND)</p> <p>▲T901 1-429-388-11 TRANSFORMER, POWER (WE405:AEP, CH, MY, SP, UK, G, AUS/WR661:AEP, SP, UK, G, IT)</p> <p>▲T901 1-429-389-11 TRANSFORMER, POWER (WE405:E/WR661:E)</p> <p>▲VS901 1-692-155-11 SELECTOR, POWER VOLTAGE (WE405:E/WR661:E)</p>																		

NOTE:

- Abbreviation
- CND : Canadian model
- G : German model
- IT : Italian model
- SP : Singapore model
- MY : Malaysia model
- AUS : Australian model
- CH : Chinese model

The components identified by mark ▲ or dotted line with mark ▲ are critical for safety. Replace only with part number specified.

Les composants identifiés par une marque ▲ sont critiques pour la sécurité. Ne les remplacer que par une pièce portant le numéro spécifié.

The components identified by mark Δ or dotted line with mark Δ are critical for safety. Replace only with part number specified.

Les composants identifiés par une marque Δ sont critiques pour la sécurité. Ne les remplacer que par une pièce portant le numéro spécifié.

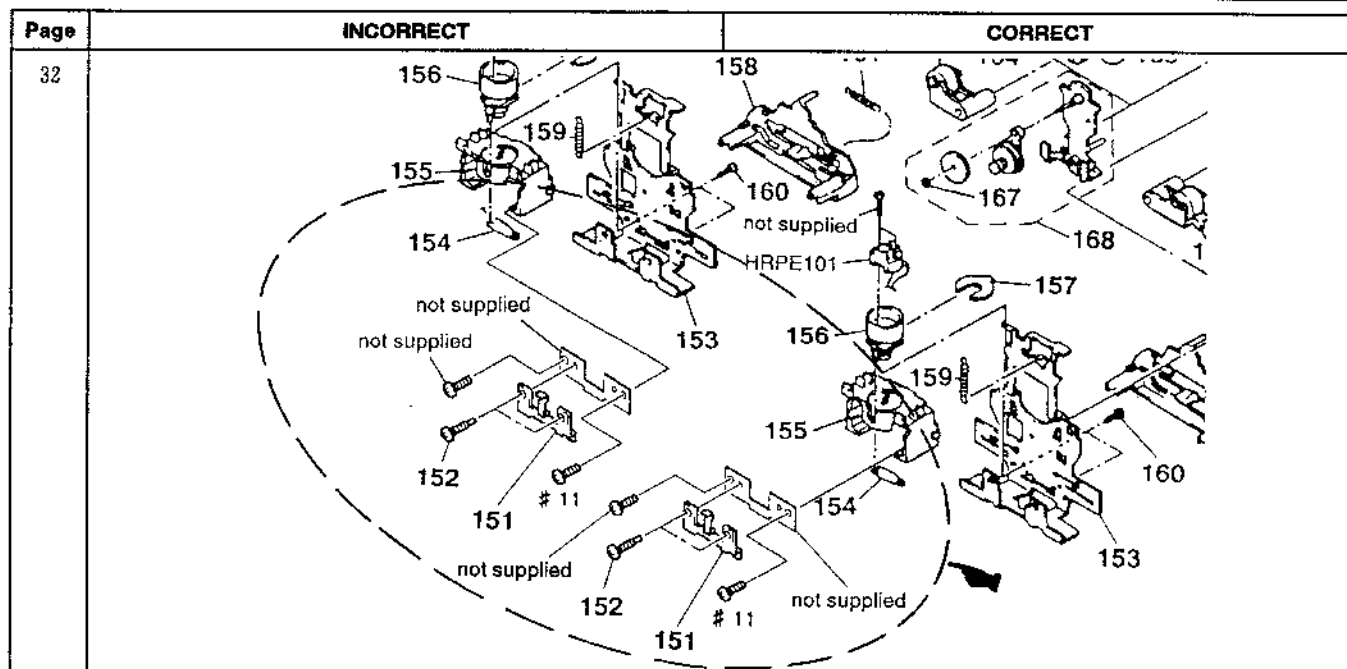

41	Ref. No	Part No	Description	Remark	Ref. No	Part No	Description	Remark
			*** MISCELLANEOUS ***				*** MISCELLANEOUS ***	
	Δ T901	429-387-11	TRANSFORMER, POWER (WE405:US, CND/WR350Z/WR661:US, CND)		Δ T901	1-429-387-11	TRANSFORMER, POWER (WE405:US, CND/WR350Z/WR661:US, CND)	
	Δ T901	429-388-11	TRANSFORMER, POWER (WE405:AEP, CH, MY, SP, UK, G, AUS/WR661:AEP, SP, UK, G, IT)		Δ T901	1-429-388-11	TRANSFORMER, POWER (WE405:AEP, CH, MY, SP, UK, G, AUS/WR661:AEP, SP, UK, G, IT)	
	Δ T901	429-389-11	TRANSFORMER, POWER (WE405:E/WR661:E)		Δ T901	1-429-389-11	TRANSFORMER, POWER (WE405:E/WR661:E)	
	Δ VS901	692-155-11	SELECTOR, POWER VOLTAGE (WE405:E/WR661:E)		Δ VS901	1-692-155-11	SELECTOR, POWER VOLTAGE (WE405:E/WR661:E)	

ACCESSORIES & PACKING MATERIALS (Revised including corrections and addition of models.)

Page	CURRENT				REVISED			
	Ref. No	Part No	Description	Remark	Ref. No	Part No	Description	Remark
41		1-551-734-11	CORD, CONNECTION (158cm AUDIO)			1-551-734-11	CORD, CONNECTION (158cm AUDIO)	
		3-810-312-11	MANUAL, INSTRUCTION (ENGLISH) (WE405:US, CND, UK, AUS/WR350Z/WR661:US, CND)			3-810-312-11	MANUAL, INSTRUCTION (ENGLISH) (WE405:US, CND, UK, AUS/WR350Z/WR661:US, CND, UK, AUS)	
		3-810-312-21	MANUAL, INSTRUCTION (FRENCH) (CND)			3-810-312-21	MANUAL, INSTRUCTION (FRENCH) (CND)	
		3-810-312-31	MANUAL, INSTRUCTION (ENGLISH, FRENCH, SPANISH, PORTUGUESE) (WE405:AEP, CH, MY, SP, E)			3-810-312-31	MANUAL, INSTRUCTION (ENGLISH, FRENCH, SPANISH, PORTUGUESE) (WE405:AEP, E/WR661:AEP, SP, E)	
		3-810-312-41	MANUAL, INSTRUCTION (GERMAN, DUTCH, SWEDISH, ITALIAN) (WE405:AEP, CH, MY, SP)			3-810-312-41	MANUAL, INSTRUCTION (GERMAN, DUTCH, SWEDISH, ITALIAN) (WE405:AEP/WR661:AEP)	
		3-810-312-51	MANUAL, INSTRUCTION (GERMAN) (WE405:G)			3-810-312-51	MANUAL, INSTRUCTION (GERMAN) (WE405:G/WR661:G)	
		3-810-312-61	MANUAL, INSTRUCTION (CHINESE) (WE405:E)			3-810-312-61	MANUAL, INSTRUCTION (CHINESE) (WE405:AEP, E, CH/WR661:SP, E)	
		3-810-312-71	MANUAL, INSTRUCTION (ARABIC) (WR661:E)			3-810-312-71	MANUAL, INSTRUCTION (ARABIC) (WR661:E)	
	*	3-932-083-01	CUSHION		*	3-932-083-01	CUSHION	
	*	3-932-085-01	INDIVIDUAL CARTON (WE405/WR350Z:CND)		*	3-932-085-01	INDIVIDUAL CARTON (WR350Z:CND)	
	*	3-932-086-01	INDIVIDUAL CARTON (WR661:AEP, UK, G, IT)		*	3-932-086-01	INDIVIDUAL CARTON (WR661:AEP, UK, G, IT)	
	*	3-932-087-01	INDIVIDUAL CARTON (WR350Z:US)		*	3-932-087-01	INDIVIDUAL CARTON (WR350Z:US)	
	*	3-934-928-01	INDIVIDUAL CARTON (WR661:US, CND)		*	3-934-927-01	INDIVIDUAL CARTON (WE405)	
					*	3-934-928-01	INDIVIDUAL CARTON (WR661:US)	
					*	3-936-956-01	INDIVIDUAL CARTON (WR661:CND, SP, E, AUS)	

2. MODEL ADDITION (TC-WR661: Singapore, Australian model)

• For detailed SP, AUS model, refer to E model.

Difference table

Page	TC-WR661: E model				TC-WR661: SP, AUS model			
	Ref.No	Part No	Description	Remark	Ref.No	Part No	Description	Remark
29	*** EXPLODED VIEWS ***				*** EXPLODED VIEWS ***			
	* 4	A-2007-487-A	MAIN BOARD, COMPLETE (WR661:E)		* 4	A-2007-487-A	MAIN BOARD, COMPLETE (WR661:SP, E)	
	* 6	3-703-571-11	BUSHING (S) (4516), CORD (WR661:E)		* 4	A-2007-590-A	MAIN BOARD, COMPLETE (WR661:AUS)	
	△7	1-696-027-11	CORD, POWER (WR661:E)		* 6	3-703-244-00	BUSHING (2104), CORD (WR661:SP, AUS)	
	△8	1-569-007-11	ADAPTER, CONVERSION 2P (WR661:E)		△7	1-575-651-21	CORD, POWER (WR661:SP, AUS)	
	* 9	3-931-436-42	PANEL, BACK (WR661:E)		* 9	3-931-436-51	PANEL, BACK (WR661:AUS)	
	△T901	1-429-389-11	TRANSFORMER, POWER (WR661:E)		* 9	3-931-436-61	PANEL, BACK (WR661:SP)	
	△VS901	1-692-155-11	SELECTOR, POWER VOLTAGE (WR661:E)		△T901	1-429-388-11	TRANSFORMER, POWER (WR661:AUS)	
					△T901	1-429-389-11	TRANSFORMER, POWER (WR661:SP, E)	
					△VS901	1-692-155-11	SELECTOR, POWER VOLTAGE (WR661:SP, E)	
34	*** ELECTRICAL PARTS LIST ***				*** ELECTRICAL PARTS LIST ***			
	*	A-2007-487-A	MAIN BOARD, COMPLETE (WR661:E)		*	A-2007-487-A	MAIN BOARD, COMPLETE (WR661:SP, E)	
					*	A-2007-590-A	MAIN BOARD, COMPLETE (AUS)	
35	CN703	1-568-106-11	PIN, CONNECTOR 4P (WR661:E)		CN703	1-568-106-11	PIN, CONNECTOR 4P (WR661:SP, E)	
38	△T901	1-429-389-11	TRANSFORMER, POWER (WR661:E)		△T901	1-429-388-11	TRANSFORMER, POWER (WR661:AUS)	
					△T901	1-429-389-11	TRANSFORMER, POWER (WR661:SP, E)	
41	*** MISCELLANEOUS ***				*** MISCELLANEOUS ***			
	△7	1-696-027-11	CORD, POWER (WR661:E)		△7	1-575-651-21	CORD, POWER (WR661:SP, AUS)	
	△8	1-569-007-11	ADAPTER, CONVERSION 2P (WR661:E)		△T901	1-429-388-11	TRANSFORMER, POWER (WR661:AUS)	
	△T901	1-429-389-11	TRANSFORMER, POWER (WR661:E)		△T901	1-429-389-11	TRANSFORMER, POWER (WR661:SP, E)	
	△VS901	1-692-155-11	SELECTOR, POWER VOLTAGE (WR661:E)		△VS901	1-692-155-11	SELECTOR, POWER VOLTAGE (WR661:SP, E)	
<p>Note: Refer to CORRECTION on page 3 about the ACCESSORIES & PACKING MATERIALS.</p>								

NOTE:

- Abbreviation
 SP : Singapore model
 AUS : Australian model

The components identified by mark △ or dotted line with mark △ are critical for safety. Replace only with part number specified.

3. PARTS CHANGE

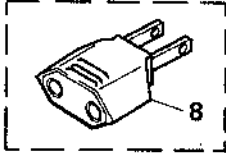
Page	FORMER				NEW			
	Ref. No	Part No	Description	Remark	Ref. No	Part No	Description	Remark
29	*** EXPLODED VIEWS ***				*** EXPLODED VIEWS ***			
					△8	1-569-008-21	ADAPTER, CONVERSION 2P (WE405:CH)	
								
					(WE405: CH)			
30	59	4-977-358-01	CUSHION (8X12.5)		59	4-977-358-11	CUSHION (8X12.5)	
	68	1-769-950-11	WIRE (FLAT TYPE)(11 CORE)		68	1-765-325-11	WIRE (FLAT TYPE)(11 CORE)	
35	*** MAIN BOARD, COMPLETE ***				*** MAIN BOARD, COMPLETE ***			
	C813	1-137-446-11	FILM 0.18uF 5%	50V	C813	1-136-168-00	FILM 0.18uF 5%	50V
	CNF803	1-568-838-11	SOCKET, CONNECTOR 21P		CNF803	1-695-344-11	SOCKET, CONNECTOR 21P	
	* CNF804	1-568-830-11	SOCKET, CONNECTOR 11P		* CNF804	1-695-334-11	SOCKET, CONNECTOR 11P	
	* CNF805	1-568-830-11	SOCKET, CONNECTOR 11P		* CNF805	1-695-334-11	SOCKET, CONNECTOR 11P	
	* CNF806	1-568-830-11	SOCKET, CONNECTOR 11P		* CNF806	1-695-334-11	SOCKET, CONNECTOR 11P	
36	R510	1-247-807-31	CARBON 10 5% 1/4W		R510		JUMPER WIRE	
37	R714	1-249-428-11	CARBON 8.2K 5% 1/4W F		R714	1-249-429-11	CARBON 10K 5% 1/4W F	
	△R723	1-217-371-00	FUSIBLE 0.47 10% 1/4W		△R723	1-219-138-91	FUSIBLE 0.47 10% 1/4W	
	R836	1-249-426-11	CARBON 5.6K 5% 1/4W (WE405)		R836	1-249-427-11	CARBON 6.8K 5% 1/4W F(WE405)	
41	*** MISCELLANEOUS ***				*** MISCELLANEOUS ***			
	68	1-769-950-11	WIRE (FLAT TYPE)(11 CORE)		△8	1-569-008-21	ADAPTER, CONVERSION 2P (WE405:CH)	
					68	1-765-325-11	WIRE (FLAT TYPE)(11 CORE)	

NOTE:

- Abbreviation
- SP : Singapore model
- MY : Malaysia model
- CH : Chinese model

The components identified by mark △ or dotted line with mark △ are critical for safety. Replace only with part number specified.

Les composants identifiés par une marque △ sont critiques pour la sécurité. Ne les remplacer que par une pièce portant le numéro spécifié.

TC-WE405/WR350Z/WR661

SONY

SERVICE MANUAL

*US Model
Canadian Model*

TC-WE405/WR350Z/WR661

AEP Model

UK Model

E Model

TC-WE405/WR661

Australian Model

Chinese Model

TC-WE405

CORRECTION-1

Correct your service manual as shown below.

Page	INCORRECT				CORRECT			
	Ref. No.	Part No.	Description	Remark	Ref. No.	Part No.	Description	Remark
31	101	X-4945-690-1	HOLDER (L) ASSY, CASSETTE		101	X-4945-691-1	HOLDER (R) ASSY, CASSETTE	
	102	X-4945-691-1	HOLDER (R) ASSY, CASSETTE		102	X-4945-690-1	HOLDER (L) ASSY, CASSETTE	

(RPC-99002)