

TC-W32/W290

SERVICE MANUAL

US Model
Canadian Model

TC-W32

AEP Model
E Model
Australian Model

TC-W290

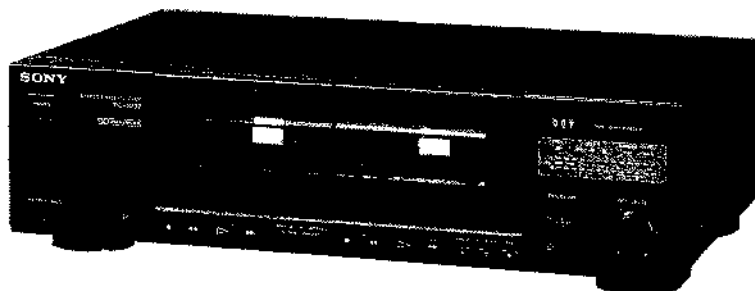

Photo : TC-W32

Model Name Using Similar Mechanism	NEW
Tape Transport Mechanism Type	TCM-210W1

SPECIFICATIONS

Recording system 4-track 2-channel stereo
Fast winding time Approx. 120 sec. (with Sony C-60 cassette)
Bias AC bias
Signal-to-noise ratio (at peak level)

Cassette (Dolby NR OFF)	Type IV (Sony Metal-Select/S)	Type II (Sony UX-S)	Type I (Sony HF-S)
	58 dB	57 dB	55 dB

Measured at peak level weighted without NR. The S/N is improved by about 15 dB at 500 Hz and by about 20 dB about 1 kHz with Dolby-C NR on, and by 5 dB at 1 kHz and by 10 dB about 5 kHz with Dolby-B NR on.

Harmonic distortion 0.4% (with Sony Type I, 160 nWb/m, 315 Hz, 3rd H.D.)
1.8% (with Sony Type IV, 250 nWb/m, 315 Hz, 3rd H.D.)

Frequency response (Dolby NR OFF)

Type IV cassette (Sony Metal-Select/S)	30 - 15,000 Hz (± 3 dB, IEC) 30 - 13,000 Hz (± 3 dB (-4dB recording))
Type II cassette (Sony UX-S)	30 - 14,000 Hz (± 3 dB, IEC)
Type I cassette (Sony HF-S)	30 - 13,000 Hz (± 3 dB, IEC)

Wow and flutter $\pm 0.15\%$ W.Peak (IEC)
0.1% W.RMS (NAB)
 $\pm 0.2\%$ W.Peak (DIN)

Inputs

Line inputs (phono jacks)	Sensitivity	0.16 V
	Input impedance	47 kilohms

Outputs

Line outputs (phono jacks)	Rated output level	0.5 V at a load impedance of 47 kilohms
	Load impedance	Over 10 kilohms
Headphones (stereo phone jack)	Output level	1 mW at a load impedance of 32 ohms

General

Power requirements Model for U.S.A.:
120 V AC, 60 Hz
Model for AEP :
220-230V AC. (or 240V AC adjustable by Sony personnel), 50/60Hz
Model for Canadian : 120V AC , 60Hz
Model for E : 120, 220, or 240 V AC adjustable, 50/60Hz
Model for the Australia:
240 V AC (or 220 V AC adjustable by Sony personnel), 50/60 Hz
Power consumption 15 W
Dimensions Approx. 430 x 123 x 290 mm (w/h/d)
(17 x 4 7/8 x 11 1/4 inches) including projecting parts and controls
Weight Approx. 3.8 kg (8 lbs 6 oz)

Supplied accessories
Audio connecting cords (2)

Design and specifications are subject to change without notice.

Note

This appliance conforms with EEC Directive 87/308/EEC regarding interference suppression.

STEREO CASSETTE DECK
SONY[®]

TABLE OF CONTENTS

Section	Title	Page
Specifications	1
1. SERVICING NOTE	3
2. GENERAL	Identifying the Parts	4
3. ADJUSTMENTS	3-1. Mechanical Adjustments	5
	3-2. Electrical Adjustments	5
4. DIAGRAMS	4-1. Block Diagram	8
	4-2. Printed Wiring Boards	11
	4-3. Schematic Diagrams	15
5. EXPLANATION OF IC TERMINALS	19
6. EXPLODED VIEWS	6-1. Chassis Section	22
	6-2. Front Panel Section	23
	6-3. Mechanism Section-1 (TCM-210W1).....	24
	6-4. Mechanism Section-2 (TCM-210W1).....	25
7. ELECTRICAL PARTS LIST	26

MODEL IDENTIFICATION

- Specification Label -

TC-W32
TC-W290

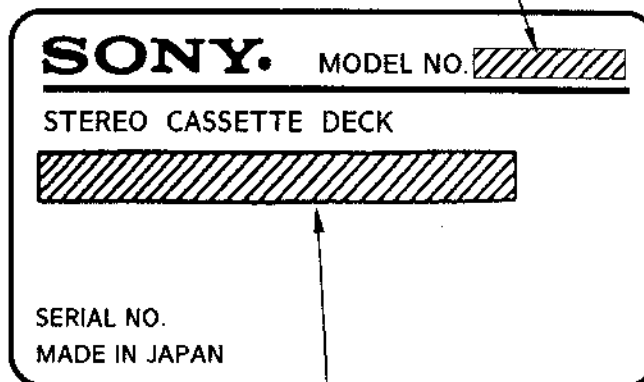

US, Canadian Model : AC 120V 60Hz 15W
 AEP Model : AC 220 - 230V ~ 50/60Hz
 E Model : AC 120, 220, 240V
 ~ 50/60Hz 15W
 Australian Model : AC 240V~ 50/60Hz

Operating voltage (E model)

Operate the unit on either 120,220 or 240V AC, 50/60Hz, Before connecting the unit to the power source, check that the operating voltage of your unit is the same as the local power line voltage.

The voltage selector is located on the rear panel.If the selector must be reset, disconnect the AC power cord and set the selector to the appropriate voltage.

VOLTAGE Selector

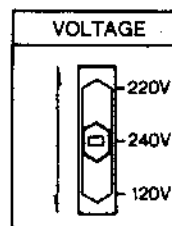

SAFETY-RELATED COMPONENT WARNING!!

COMPONENTS IDENTIFIED BY MARK Δ OR DOTTED LINE WITH MARK Δ ON THE SCHEMATIC DIAGRAMS AND IN THE PARTS LIST ARE CRITICAL TO SAFE OPERATION. REPLACE THESE COMPONENTS WITH SONY PARTS WHOSE PART NUMBERS APPEAR AS SHOWN IN THIS MANUAL OR IN SUPPLEMENTS PUBLISHED BY SONY.

ATTENTION AU COMPOSANT AYANT RAPPORT À LA SÉCURITÉ!

LES COMPOSANTS IDENTIFIÉS PAR UNE MARQUE Δ SUR LES DIAGRAMMES SCHÉMATIQUES ET LA LISTE DES PIÈCES SONT CRITIQUES POUR LA SÉCURITÉ DE FONCTIONNEMENT. NE REMPLACER CES COMPOSANTS QUE PAR DES PIÈCES SONY DONT LES NUMÉROS SONT DONNÉS DANS CE MANUEL OU DANS LES SUPPLÉMENTS PUBLIÉS PAR SONY.

SECTION 1 SERVICING NOTE

SAFETY CHECK-OUT

After correcting the original service problem, perform the following safety check before releasing the set to the customer :

Check the antenna terminals, metal trim, "metallized" knobs, screws, and all other exposed metal parts for AC leakage. Check leakage as described below.

LEAKAGE TEST

The AC leakage from any exposed metal part to earth ground and from all exposed metal parts to any exposed metal part having a return to chassis, must not exceed 0.5 mA (500 microampers.).

Leakage current can be measured by any one of three methods.

1. A commercial leakage tester, such as the Simpson 229 or RCA WT-540A. Follow the manufacturers' instructions to use these instruments.
2. A battery-operated AC milliammeter. The Data Precision 245 digital multimeter is suitable for this job.
3. Measuring the voltage drop across a resistor by means of a VOM or battery-operated AC voltmeter. The "limit" indication is 0.75V, so analog meters must have an accurate low-voltage scale. The Simpson 250 and Sanwa SH-63Trd are examples of a passive VOM that is suitable. Nearly all battery operated digital multimeters that have a 2V AC range are suitable. (See Fig. A)

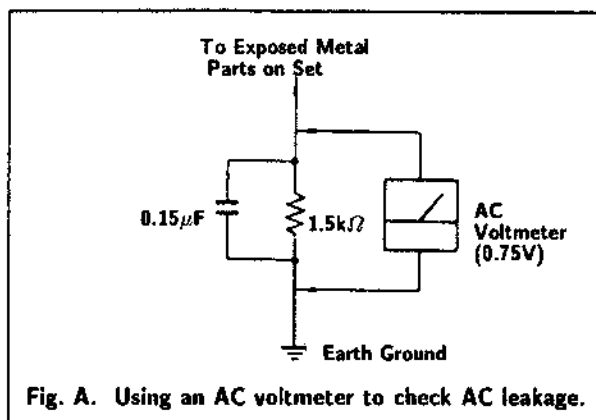

How to install CAM(A) and CAM(B)

When the CAM(A) and CAM(B) removed or replaced. Make sure to install these cam's (marked **A** position) with marked **B** position of chassis as show in Fig. 1.

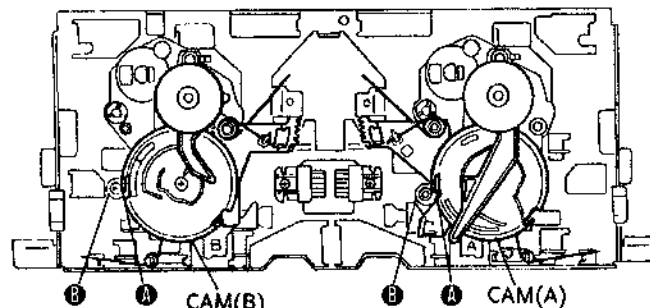

Fig. 1. STOP POSITION

TEST MODE

Turned the power on after connect ① pin of IC801 to ground. (shorted between 1 and 2 pin of TP801). There are two type of the test can be done as show in below.

1. ALL LED LIGHT

ALL LED will light one second after the power on.

2. HIGH SPEED PLAYBACK MODE

Excutes high speed dubbing when the HIGH SPEED button is pressed during normal speed mode of DECK-A or DECK-B.

Identifying the Parts

Front Panel

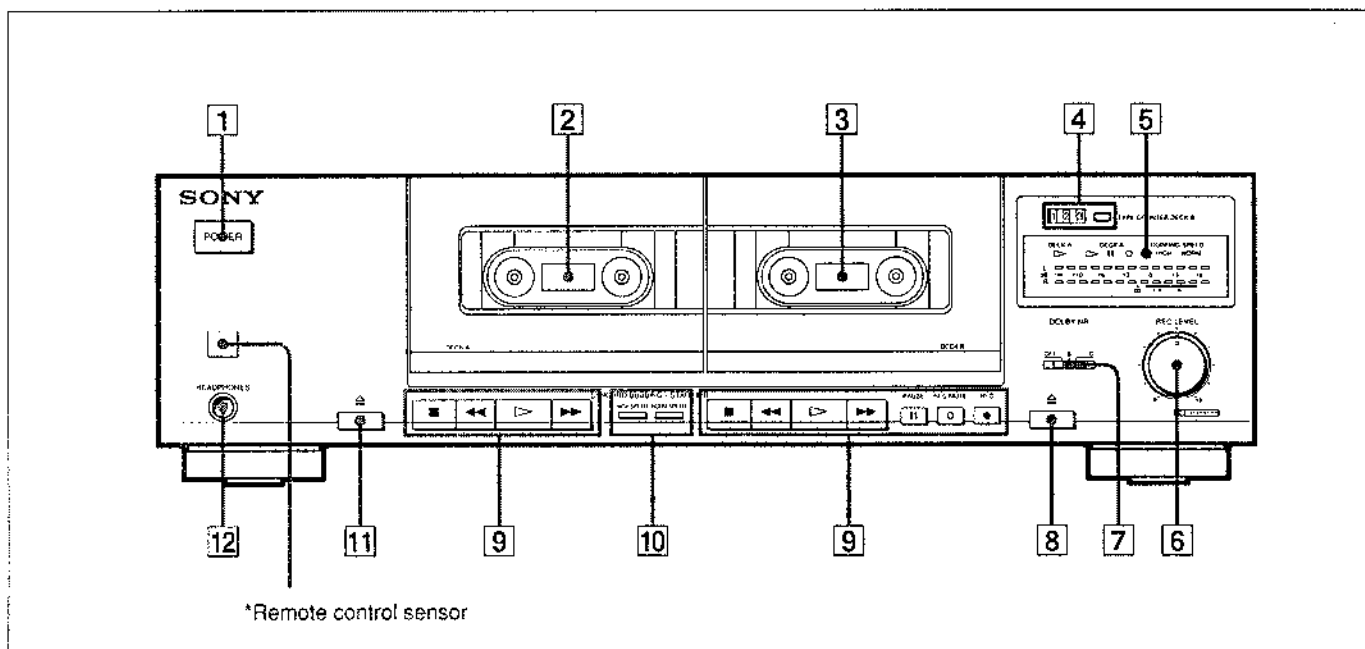



For details, refer to the page number indicated in parenthesis.

- 1 POWER switch
- 2 Deck A
- 3 Deck B
- 4 TAPE COUNTER and reset button (deck B)
- 5 Display panel
- 6 REC (recording) LEVEL control (pages 9 and 10)
- 7 DOLBY NR (Dolby noise reduction) switch (pages 7 and 9)
- 8 ▲ (eject) button (deck B)
- 9 Tape operation buttons
 - (stop) button
 - ◀◀ (leftward fast winding) button
 - ▶▶ (play) button
 - ▶▶ (rightward fast winding) button
 - || PAUSE button (deck B only)
 - REC MUTE (record muting) button (deck B only) (page 11)
 - REC (recording) button (deck B only)

- 10 SYNCHRO DUBBING buttons (page 12)
 - HIGH SPEED button
 - NORM (normal) SPEED button
- 11 ▲ (eject) button (deck A)
- 12 HEADPHONES jack (stereo phone jack)

*Remote control sensor

You can remotely control this cassette deck with:

- A remote commander that came with a Sony amplifier or receiver if it has the  mark and cassette deck control capability.
- Any optional Sony remote commander with the  mark and cassette deck control capability.

SECTION 3 ADJUSTMENTS

3-1. MECHANICAL ADJUSTMENTS

PRECAUTION

1. Clean the following parts with a denatured alcohol-moistened swab :

record/playback/erase head	pinch roller
rubber belts	capstan
idlers	
2. Demagnetize the record/playback head with a head demagnetizer.
(Head demagnetizer do not approach for the erase head.)
3. Do not use a magnetized screwdriver for the adjustment.
4. After the adjustments, apply suitable locking compound to the parts adjusted.
5. The adjustments should be performed with the rated power supply voltage unless otherwise noted.

Torque Measurement

Torque	Torque meter	Meter reading
Forward	CQ-102C	30 to 70 g-cm (0.42 - 0.97 oz-inch)
Forward back tension	CQ-102C	1.5 to 7 g-cm (0.02 to 0.096 oz-inch)
FF, REW	CQ-201B	less than 60 g-cm (less than 0.83 oz-inch)

3-2. ELECTRICAL ADJUSTMENTS

PRECAUTION

1. The adjustment should be performed in the publication.
(Be sure to make playback adjustment at first.)
2. The adjustment and measurement should be performed for both L-CH and R-CH.
 - Switch position
DOLBY NR switch : OFF
 - Standard record position :
Deliver the standard input signal level to input jack and set the REC LEVEL control to obtain the standard output signal level as follows.

—Record Mode—

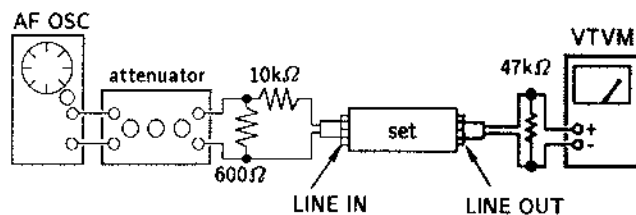

Standard Input Level

input terminal	LINE IN
source impedance	10kΩ
input signal level	0.5V (−3.8dB)

Standard Output Level

output terminal	LINE OUT
load impedance	47kΩ
output signal level	0.5V (−3.8dB)

Test Tape

Tape	Contents	Use
P-4-A100	10kHz, -10dB	Azimuth Adjustment
P-4-L300	315Hz, 0dB	PB Level Adjustment
WS-48B	3kHz, 0dB	Tape Speed Adjustment

0dB=0.775V

Record/Playback Head Azimuth Adjustment

Procedure :

1. Forward playback Mode

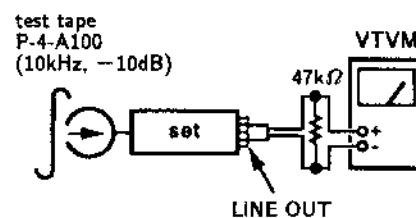

2. Turn the adjustment screw for the maximum output levels. If these levels do not match, turn the adjustment screw until both of output levels match together within 1dB.

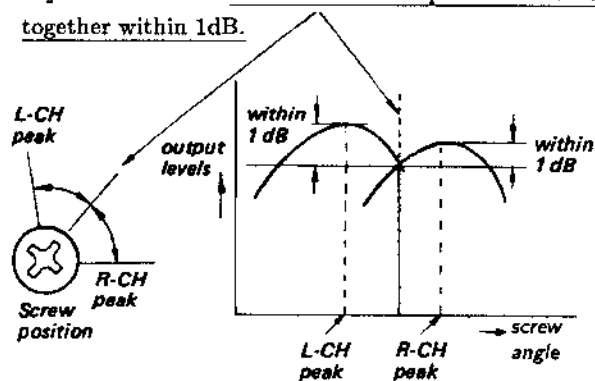

3. Playback Mode

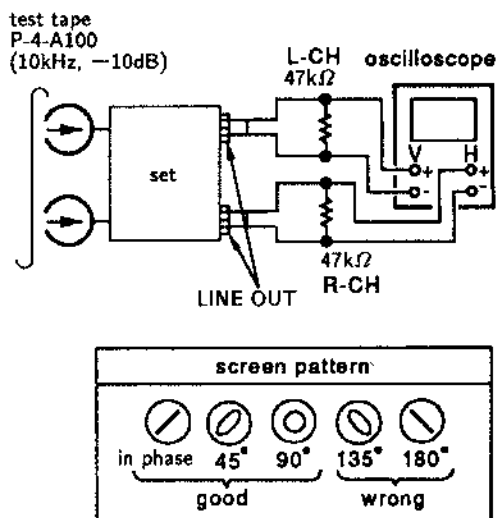

4. Change the revers playback mode and repeat the steps 1 to 3.
5. After the adjustment, lock the adjustment screws with suitable locking compound.

Adjustment Location : —record/playback head—

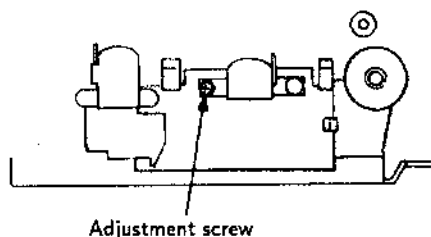

Tape Speed Adjustment

Procedure :

—Forward playback Mode—

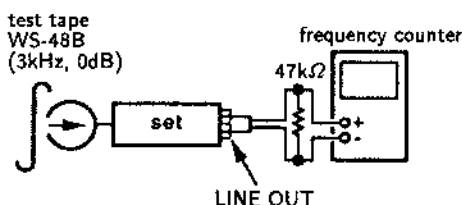

Perform high speed adjustment before normal speed adjustment.

<high speed adjustment>

1. Shorted the both terminal of the connector TP801 by read wire to short between ① pin of IC801 and Ground.
2. Set to FWD playback mode.
3. Keep on pressing the HIGH SPEED DUBBING switch.

4. Adjust RV601 so that the frequency counter reading becomes $5,700 \pm 20\text{Hz}$.
5. After adjustment, disconnect TP801 shorted in step 1.

<normal speed adjustment>

1. Set to FWD playback mode.
2. Adjust RV602 so that the frequency counter reading becomes $3,000 \pm 10\text{Hz}$.

Frequency difference between the beginning and the end of the tape should be within 1.5%.

Frequency difference between deck A and deck B the beginning of the tape should be within 1.5%.

Adjustment Location : AUDIO board

Playback Level Adjustment

Procedure :

—Forward playback Mode—

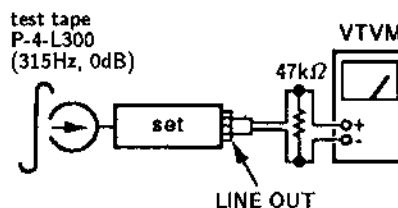

Adjust deck A (RV101/L-ch and RV201/R-ch), B (RV111/L-ch and RV211/R-ch) so the VTVM reading becomes the adjustment limits below.

Adjustment Value :

LINE OUT level : $-7.7 \pm 0.5\text{dB}$ (0.301 to 0.338V)

Level difference between channels : within 0.5dB.

Confirm the LINE OUT level does not change in playback mode while changing the mode from playback to stop several times.

Adjustment Location : AUDIO board

Record Bias Adjustment (DECK-B only)

Setting :

REC LEVEL control : Standard record position (Refer to page 5).

Procedure :

1. Record Mode

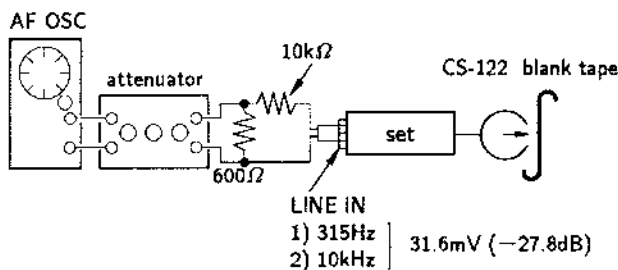

2. Playback Mode

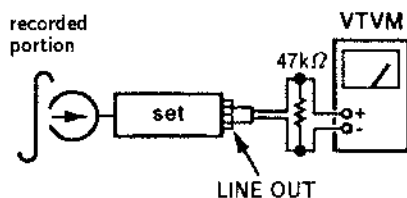

Playback the signal recorded in step 1.

Confirm that the 10kHz playback output is $0 \pm 0.5\text{dB}$ relative to the 315Hz output. If necessary, adjust RV102 (L-ch), RV202 (R-ch) and repeat the steps given above.

Adjustment Location : AUDIO board

Record Level Adjustment (DECK-B only)

Setting :

REC LEVEL control : Standard record position (Refer to page 5).

Procedure :

1. Record Mode

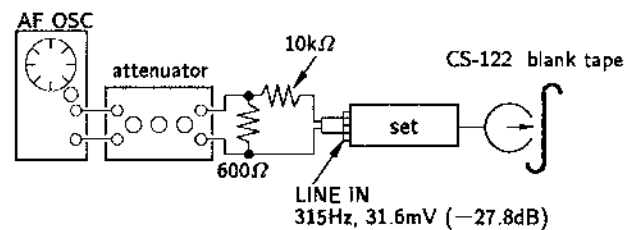

2. Playback Mode

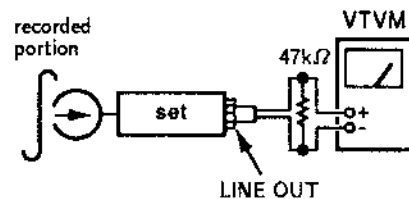

Confirm playback the tape recorded become adjustment level as follows.

If necessary, adjust RV103(L-ch), RV203(R-ch) and repeat the step 1 and 2.

Adjustment Value :

LINE OUT level : $-27.7 \pm 0.5\text{dB}$ (30.2 to 33.8mV)

Adjustment Location : AUDIO board

— Adjustment Parts Location Diagrams —

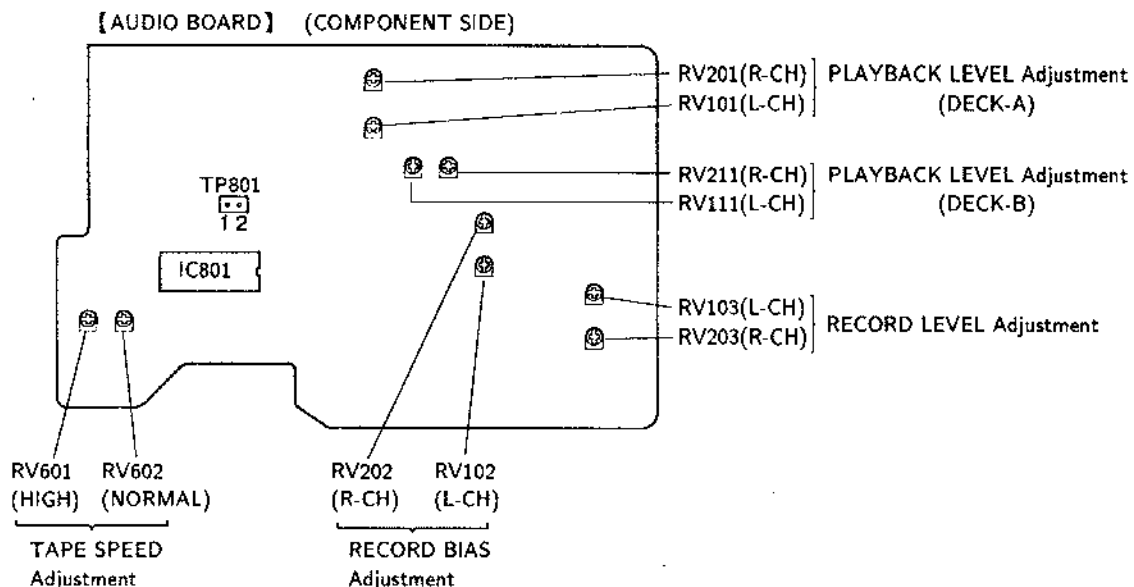

SECTION 4 DIAGRAMS

4-1. BLOCK DIAGRAM

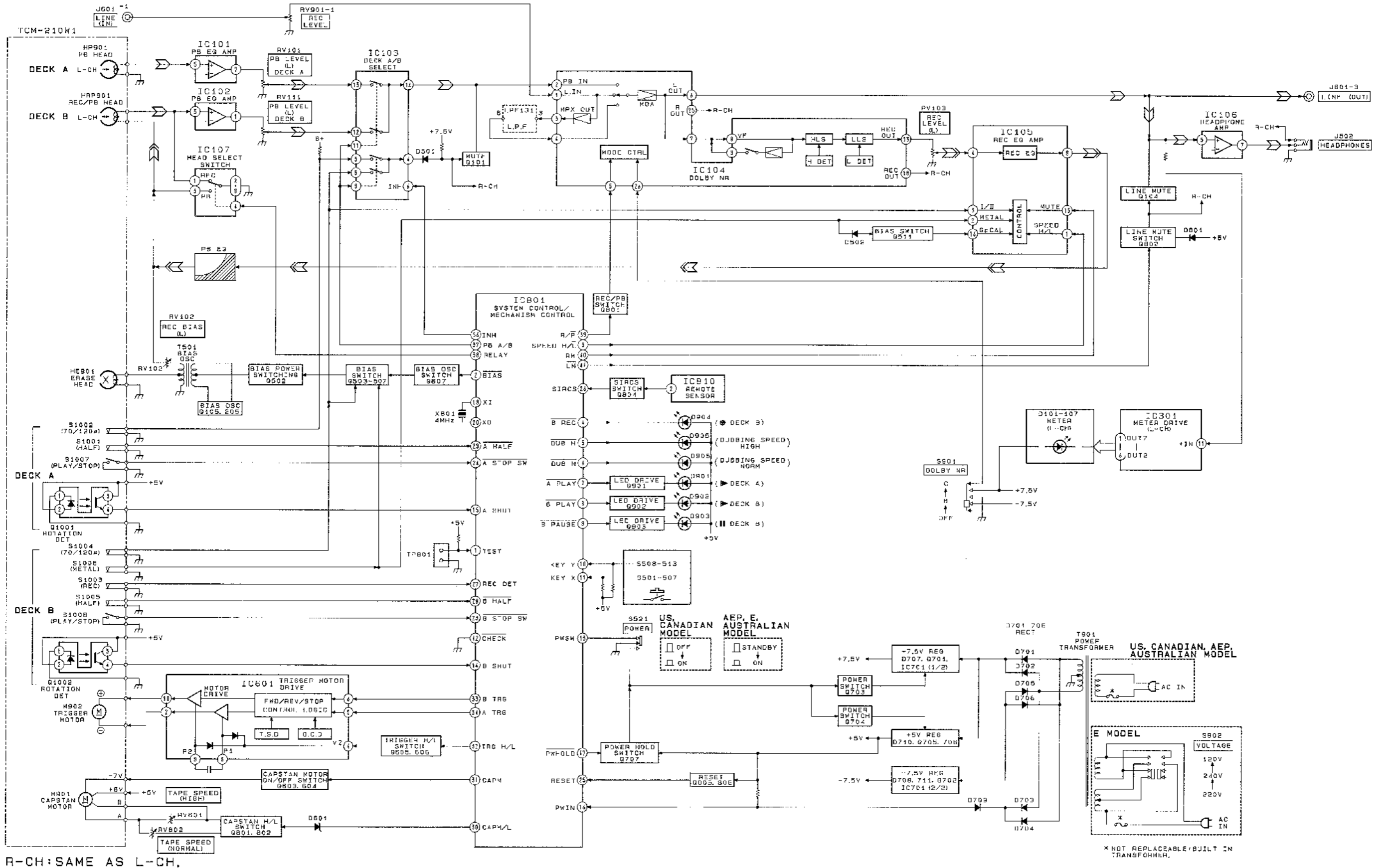

• Semiconductor Lead Layouts.

LB1641

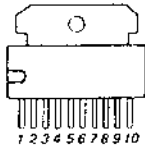

DTC144ES
2SA1175-HFE



2SC2001-LK
2SD1387-3



1N4148M
10E2N

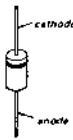

μPC1330HA-MA



NJL5615K-B

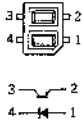

HZS6A1L
HZS6C3L
HZS9A2L

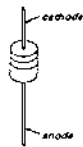

SEL4214S

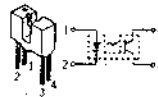

DTA114ES
DTA144ES
DTC114ES
DTC143TS
2SC2603-EF
2SD2144S-UVW



2SB1094-LK
2SD2012

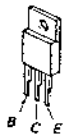

UZ-2.0BS

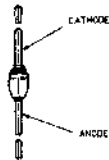

SEL4414E-C
SEL4914A-CD

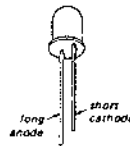

CIRCUIT BOARDS LOCATION

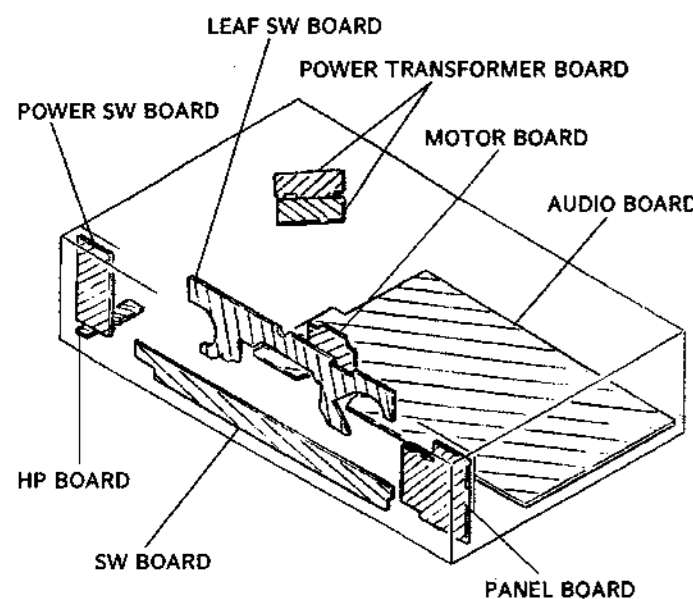

• SEMICONDUCTOR LOCATION

Ref. No.	Location	Ref. No.	Location
D101	H-1	IC701	B-12
D102	H-2	IC801	F-13
D103	H-2	IC810	F-16
D104	H-2		
D105	H-3		
D106	H-3	Q101	C-8
D107	H-4	Q104	C-8
D107	H-4	Q105	G-9
D201	G-1	Q201	C-8
D202	G-2	Q204	B-6
D203	G-2		
D204	G-2	Q205	F-10
D205	G-3	Q502	G-10
D206	G-3	Q503	G-8
D207	G-4	Q504	G-8
D207	G-4	Q505	G-8
D501	B-8		
D502	G-7	Q506	G-8
D601	F-14	Q507	G-8
D701	C-14	Q511	G-7
D701	C-14	Q601	E-15
D703	C-14	Q602	F-15
D704	C-14		
D705	B-14	Q603	G-14
D706	B-14	Q604	G-14
D707	C-11	Q605	G-14
D708	B-12	Q606	G-14
D709	B-14	Q701	A-12
D710	B-14		
D711	B-12	Q702	A-11
D801	H-10	Q703	C-12
D901	H-1	Q704	B-14
D902	H-2	Q705	B-14
D903	H-2	Q706	A-13
D904	H-3		
D905	H-3	Q707	D-13
D906	H-3	Q801	F-12
		Q802	G-11
		Q804	E-13
		Q805	E-14
		Q806	D-14
		Q807	E-12
		Q901	E-12
		Q902	E-12
		Q903	E-12
IC101	B-10	Q1001	F-19
IC102	D-10	Q1002	F-24
IC103	B-8		
IC104	D-8		
IC105	F-8		
IC106	B-5		
IC107	E-9		
IC301	G-3		
IC401	G-2		
IC601	G-14		

Note:
 : Pattern on the side which is seen.

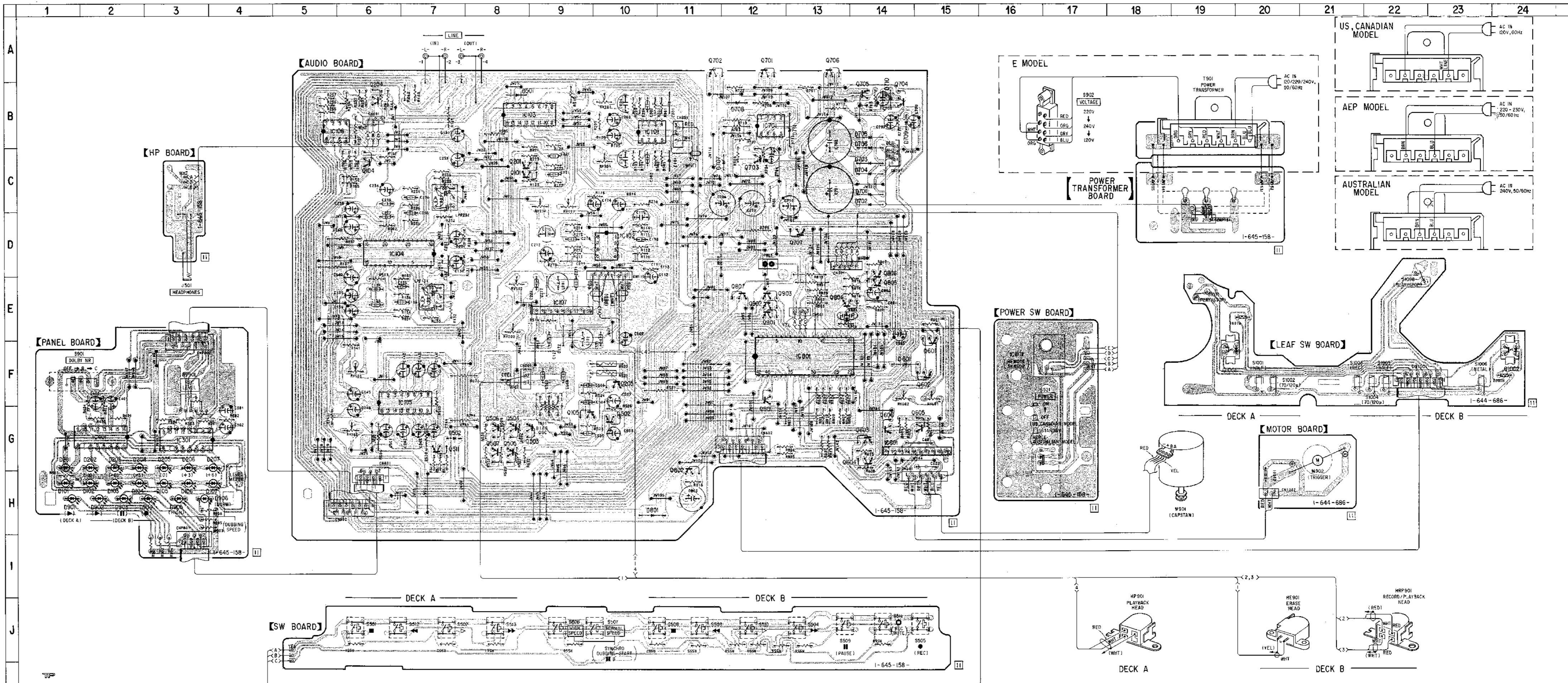

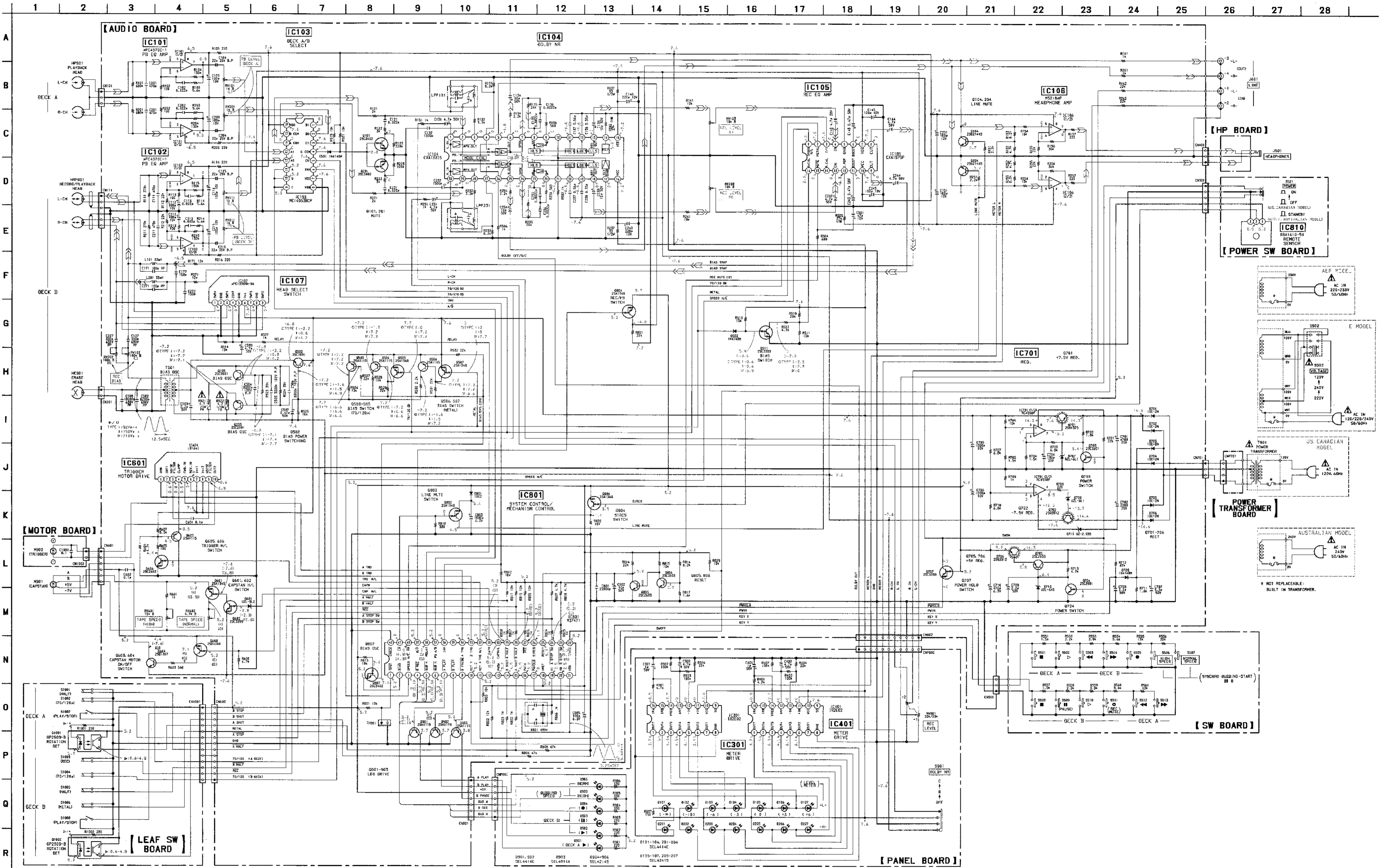

Note:

- All capacitors are in μ F unless otherwise noted. pF, μ F, or F 50WV or less are not indicated except for electrolytics and tantalums.
- All resistors are in Ω and $\frac{1}{4}W$ or less unless otherwise specified.
- Δ : Internal component.
- $\text{---}/\text{---}$: fusible resistor.

Note:
The components identified by mark Δ or dotted line with mark Δ are critical for safety. Replace only with part number specified.

Note:
Les composants identifiés par une marque Δ ou par une ligne pointillée avec une marque Δ sont critiques pour la sécurité. Ne les remplacer que par une pièce portant le numéro spécifié.

• --- : B = Line
• --- : B = Line
• --- : adjustment for repair.
• AC voltage readings in the bias oscillator with a VTVM.
• Voltage and waveforms are dc with respect to ground under no-signal (detuned) conditions.
no mark: STOP
(): DUBBING SPEED (NORMAL)
(): DUBBING SPEED (HIGH)
• Voltages are taken with a VOM (input impedance 10M Ω). Voltage variations may be noted due to normal production tolerances.
• Waveforms are taken with an oscilloscope. Voltage variations may be noted due to normal production tolerances.
• Signal path.
• PB
• REC

SECTION 5 EXPLANATION OF IC TERMINALS

● IC801 (M37471M2-118SP) SYSTEM CONTROL / MECHANISM CONTROL

Pin No.	Terminal Name	I/ O	Terminal explanation									
1	TEST	I	TEST mode selector terminal "H" : NORMAL MODE, "L" : TEST MODE									
2	BIAS	O	Bias osc terminal "L" : ON									
3	EQ H/L	O	NORMAL/ HIGH selector for recording equalizer, "H" : HIGH "L" : NORMAL									
4	B REC LED	O	LED drive terminal for B deck rec mode "L" : LIGHT									
5	DUB H LED	O	LED drive terminal for HIGH SPEED DUBBING "L" : LIGHT									
6	DUB N LED	O	LED drive terminal for NORMAL SPEED DUBBING "L" : LIGHT									
7	A PLAY LED	O	LED drive terminal for A deck play mode "L" : LIGHT									
8	B PLAY LED	O	LED drive terminal for B deck play mode "L" : LIGHT									
9	B PAU LED	O	LED drive terminal for B deck pause mode "L" : LIGHT									
10	KEY Y	I	KEY Y INPUT	STOP-A	PLAY-A	REW-B	FF-A	REC-B	DUB H	DUB N		
	KEY X		KEY X INPUT	STOP-B	PAUSE-B	PLAY-B	REC MUTE-B	REW-A	FF-A		-	
11	KEY X		IC801 ⑩⑪ピン	0V	0.65V	1.35V	2.15V	2.84V	3.57V		4.32V	
12	NC	-	Not in used (OPEN)									
13	PW IN (SW)	I	POWER switch input terminal "H" : POWER ON									
14	B SHUT	I	S-side reel rotation detection at DECK-B									
15	A SHUT	I	S-side reel rotation detection at DECK-A									
16	PW IN (AC)	I	power in terminal "H" : POWER ON									
17	PW HOLD	O	power holding output terminal "L" : POWER ON HOLDING									
18	VREF	I	Reference voltage +5V									
19	X IN	I	Oscillation input terminal (4MHz)									
20	X OUT	O	Oscillation output terminal									
21	VSS	-	GND terminal									
22	VCC	I	+5V power supply terminal									
23	B PLAY SW	I	Mechanism play mode switch input for DECK-B "H" : PLAY									
24	A PLAY SW	I	Mechanism play mode switch input for DECK-A "H" : PLAY									
25	RESET	I	RESET signal input terminal "L" : RESET									
26	SIRCS	I	SIRCS signal input terminal									
27	B REC DT	I	REC claw detection at DECK-B "L" : REC CLAW PROOF									
28	B HALF	I	Half pawl input for DECK-B "L" : AVAILABLE									
29	A HALF	I	Half pawl input for DECK-A "L" : AVAILABLE									
30	CAPM H/L	O	Tape speed selector "L" : HIGH SPEED "H" : NORMAL SPEED									
31	CAPM ON	O	Capstan motor ON/OFF switch "L" : ON									
32	TRGH/L	O	Clamp voltage output terminal									
33	BTRG	O	Trigger signal output for DECK-B									
34	ATRG	O	Trigger signal output for DECK-A									
35	NC	-	Not in used (OPEN)									
36	INH	O	INH signal output terminal									
37	PB A/B	O	DECK-A/ DECK-B play selector, at DECK-B, "H" : DECK-A "L" : DECK-B									
38	RELAY	O	Recording/ play selector at B-DECK, "H" : RECORDING									
39	REC/PB	O	Recording/ play selector for dolby IC, "H" : PLAY									
40	R MUTE	O	Recording MUTE ON/ OFF "L" : MUTE ON									
41	L MUTE	O	LINE MUTE ON/ OFF "L" : MUTE ON									
42	ER CHECK	O	Error check terminal "L" : Checked, "H" : Not Checked									

● IC105 CXA1579P

Pin No.	Terminal Name	I/ O	Terminal explanation
1	SPEED	I	Tape speed selector terminal "H" : HIGH
2	METAL	I	Metal tape selector terminal "H" : METAL
3	TAPE EQ	I	Tape equalizer selector terminal "H" : CrO2
4	REC IN1	I	Recording equalizer amp input terminal
5	GND	—	GND terminal
6	BOOST1	I	External capacitor for low-pass boost connecting terminal
7	VEE	—	-7.5V power supply terminal
8	REC OUT1	O	Recording equalizer amp output terminal
9	REC OUT2	O	Recording equalizer amp output terminal
10	VCC	—	+7.5V power supply terminal
11	BOOST2	I	External capacitor for low-pass boost connecting terminal
12	IREF	O	Standard current setting terminal of monolithic filter
13	REC IN2	I	Recording equalizer amp input terminal
14	REC CAL	I	Recording calibration terminal "H" : Recording level gain down (Not in used)
15	REC MUTE	I	Recording Mute ON/ OFF selector terminal "H" : Mute OFF "L" : Mute ON
16	GP CAL	I	High-pass calibration terminal "H" : High-pass level gain down "L" : High-pass level gain up

• IC BLOCK DIAGRAMS

CXA1579P

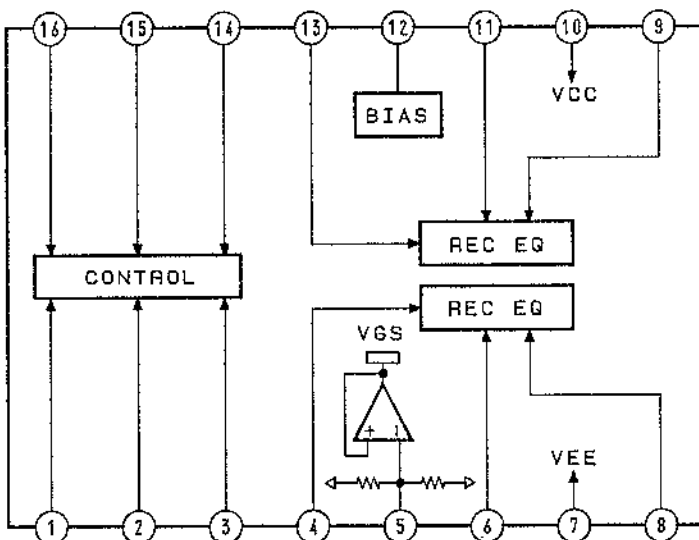

μPD4053BC

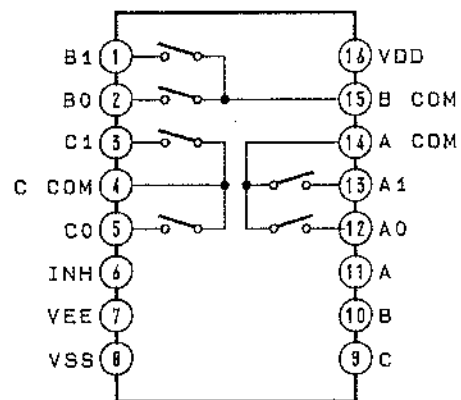

IR2E02

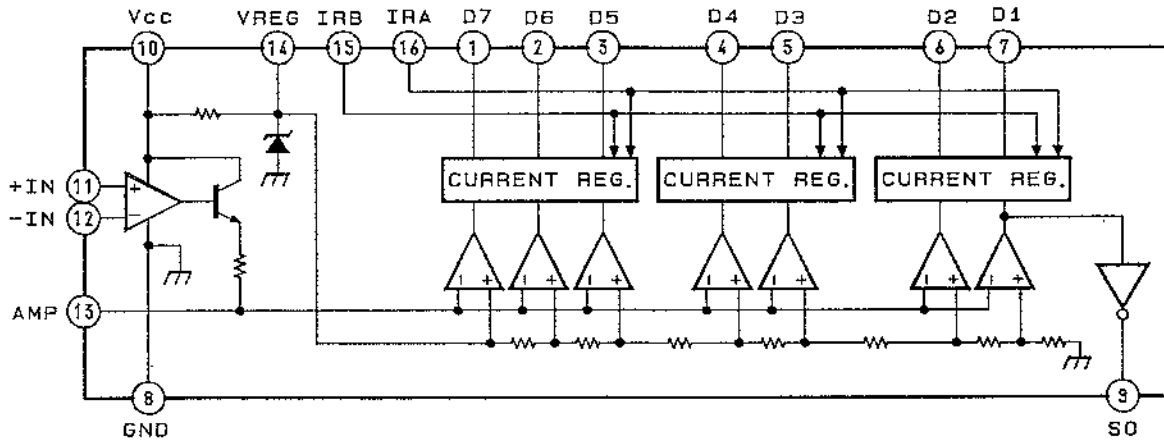

LB1641

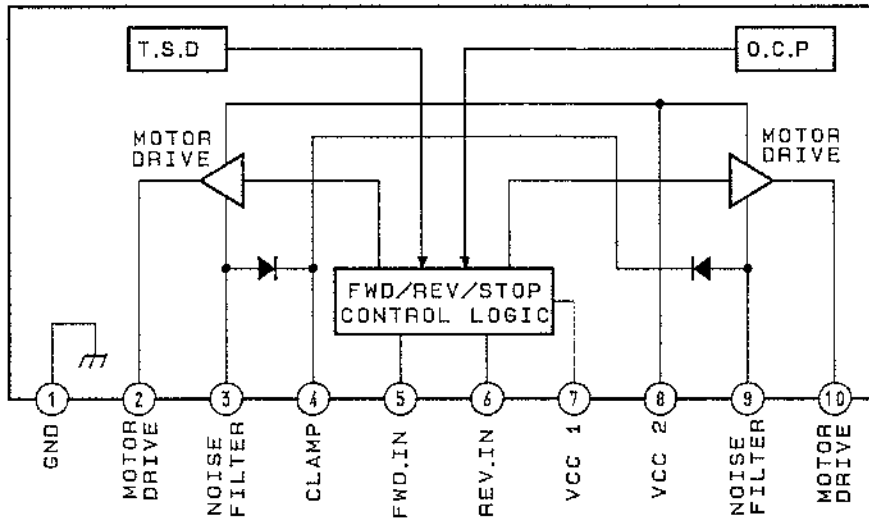

μPC1330HA

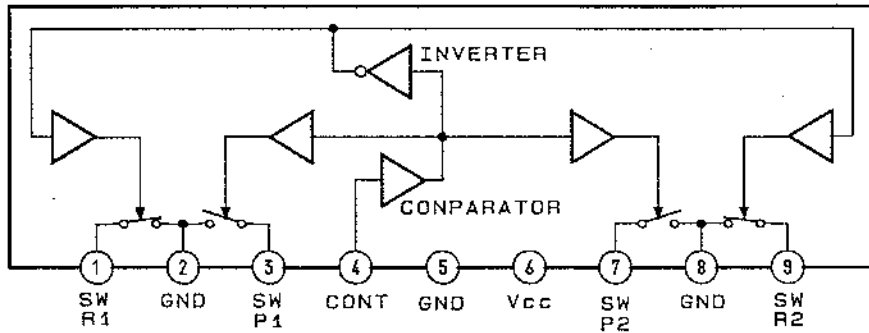

SECTION 6 EXPLODED VIEWS

NOTE:

- -XX, -X mean standardized parts, so they may have some differences from the original one.
- The construction parts of an assembled part are indicated with a collation number in the remark column.
- Color indication of Appearance Parts
Example:
KNOB, BALANCE (WHITE)....(RED)

Parts color Cabinet's color

- Items marked "*" are not stocked since they are seldom required for routine service. Some delay should be anticipated when ordering these items.
- The mechanical parts with no reference number in the exploded views are not supplied.
- Hardware (# mark) list is given in the last of this parts list.

The components identified by mark Δ or dotted line with mark Δ are critical for safety. Replace only with part number specified.

Les composants identifiés par une marque Δ sont critiques pour la sécurité. Ne les remplacer que par une pièce portant le numéro spécifié.

6-1. CHASSIS SECTION

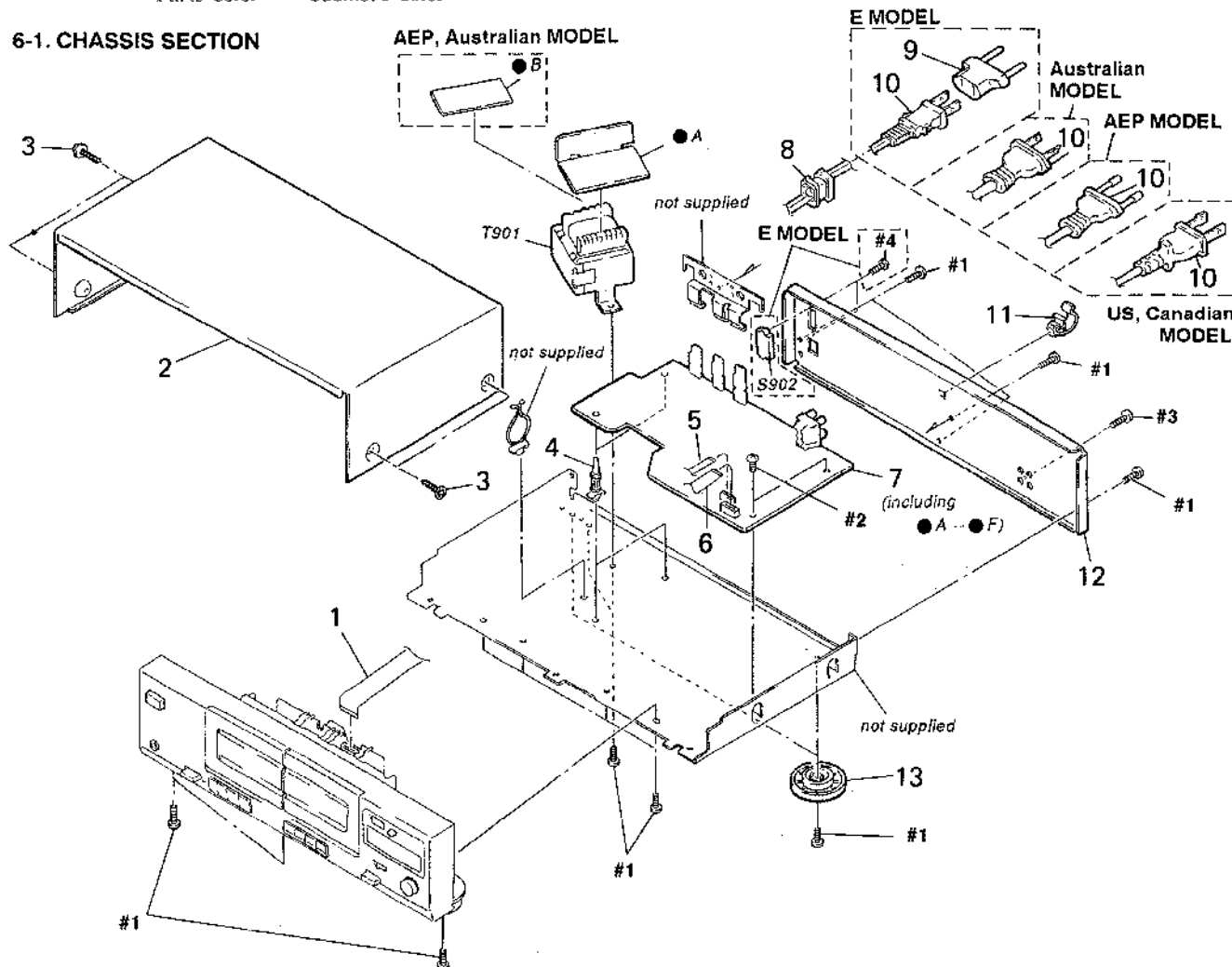

Ref. No.	Part No.	Description	Remark	Ref. No.	Part No.	Description	Remark
1	1-534-517-00	WIRE (FLAT TYPE) (13 CORE)		* 11	4-949-235-01	HOOK	
2	3-332-578-61	CASE		* 12	3-382-279-01	PANEL, BACK (US, Canadian)	
3	3-704-366-01	SCREW (CASE) (M3X8)		* 12	3-382-279-21	PANEL, BACK (AEP)	
* 4	3-346-265-11	HOLDER, PC BOARD		* 12	3-382-279-31	PANEL, BACK (Australian)	
5	1-690-420-11	WIRE, FLAT TYPE (7 CORE)		* 12	3-382-279-41	PANEL, BACK (E)	
6	1-575-784-11	WIRE (FLAT TYPE) (11 CORE)		13	4-943-148-32	FOOT (F58175SW)	
* 7	A-2006-824-A	AUDIO BOARD, COMPLETE		ΔS902	1-692-155-11	SELECTOR, POWER VOLTAGE (E)	
* 8	3-703-244-00	BUSHING (2104), CORD (AEP, Australian)		ΔT901	1-450-990-11	TRANSFORMER, POWER (US, Canadian)	
* 8	3-703-571-11	BUSHING (S) (4516), CORD (US, Canadian, E)		ΔT901	1-450-991-11	TRANSFORMER, POWER (AEP, Australian)	
Δ9	1-569-007-11	ADAPTER, CONVERSION 2P (E)		ΔT901	1-450-992-11	TRANSFORMER, POWER (E)	
Δ10	1-551-188-XX	CORD, POWER (E)					
Δ10	1-555-795-00	CORD, POWER, EURO PLUG (AEP)					
Δ10	1-558-945-11	CORD, POWER (POLAR. SPT-1) (US, Canadian)					
Δ10	1-559-912-11	CORD, POWER (Australian)					

6-2. FRONT PANEL SECTION

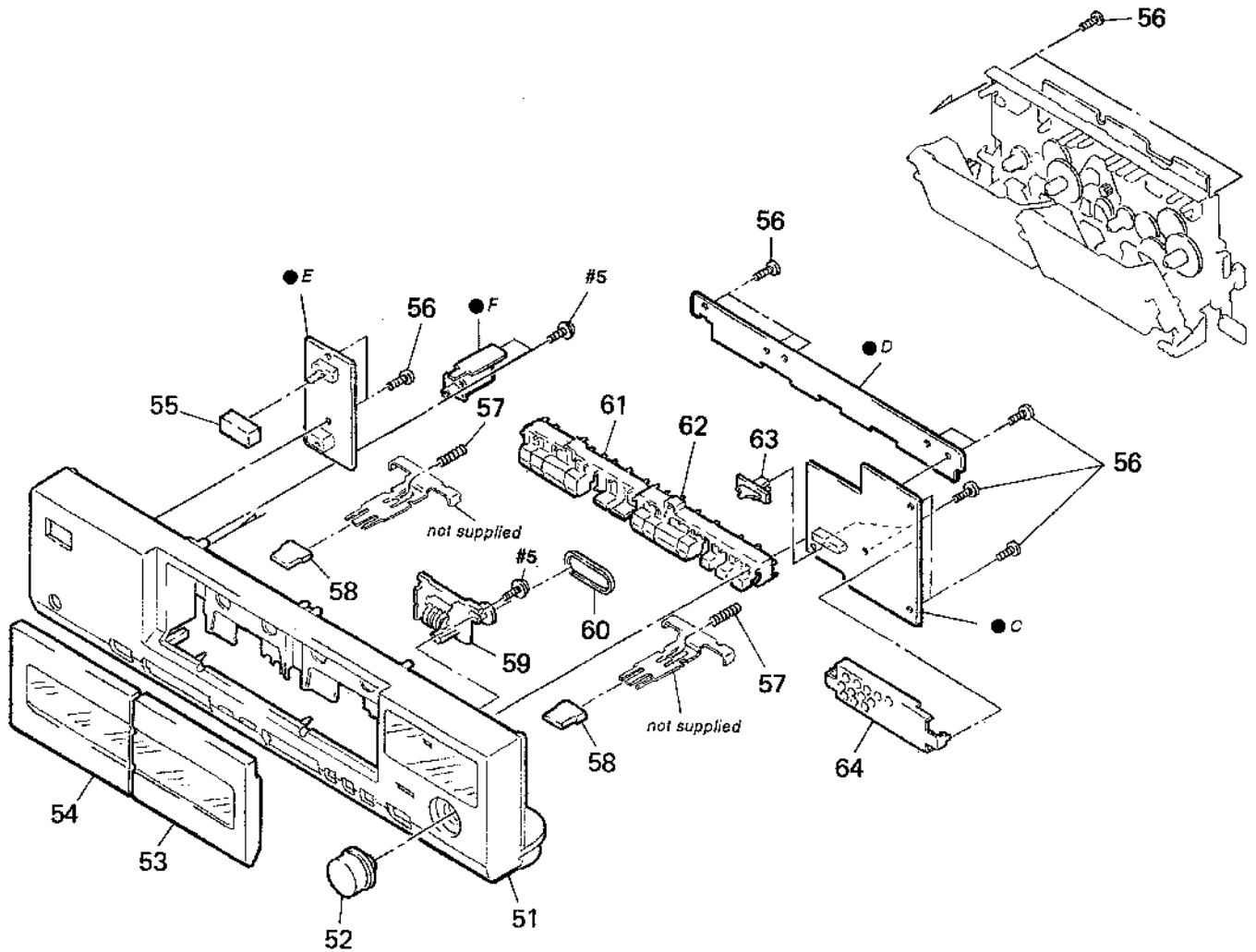

Ref. No.	Part No.	Description	Remark	Ref. No.	Part No.	Description	Remark
51	X-3365-514-1	PANEL ASSY, FRONT (W290)		57	3-382-382-01	SPRING, COMPRESSION	
51	X-3365-519-1	PANEL ASSY, FRONT (W32)		58	3-359-907-11	BUTTON (EJECT)	
52	3-382-266-01	KNOB (R)		59	1-548-586-41	COUNTER, TAPE (MIDDLE TYPE)	
53	X-3365-516-1	LID (B) ASSY, CASSETTE		60	3-143-124-XX	BELT, COUNTER	
54	X-3365-515-1	LID (A) ASSY, CASSETTE		61	3-382-269-01	BUTTON (A)	
55	4-922-921-01	BUTTON (POWER)		62	3-382-273-01	BUTTON (B)	
56	4-951-620-01	SCREW (2.6X8), +BVTP		63	3-382-254-01	KNOB (NR)	
				* 64	3-382-253-01	HOLDER, LED	

6-3. MECHANISM SECTION-1
(TCM-210W1)

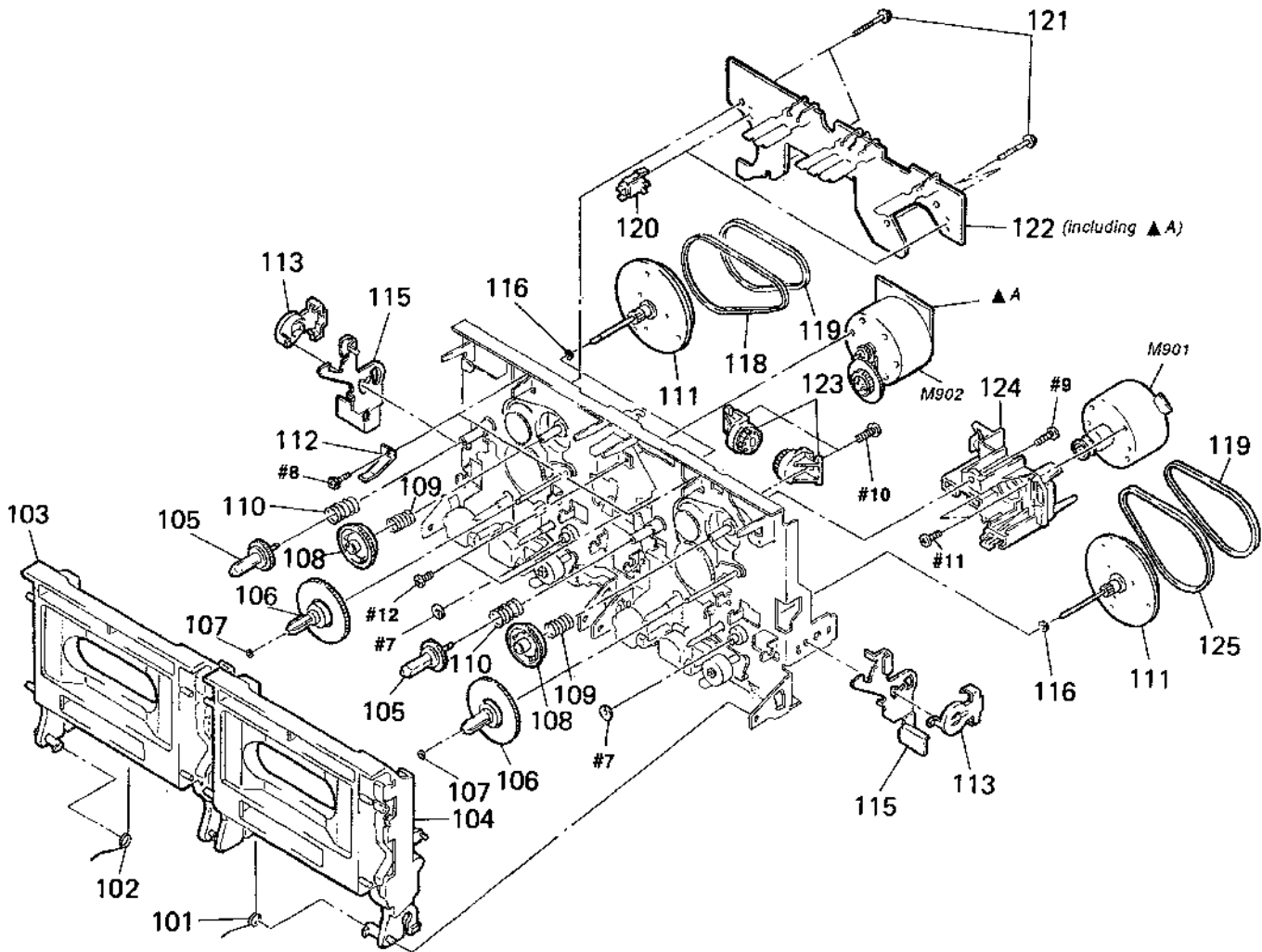

Ref. No.	Part No.	Description	Remark	Ref. No.	Part No.	Description	Remark
101	3-381-788-01	SPRING (LOADING B), TORSION		* 115	3-354-954-01	LEVER (LOCK LEVER R)	
102	3-381-787-01	SPRING (LOADING A), TORSION		116	3-701-437-21	WASHER	
103	X-3365-440-1	HOLDER (A) ASSY, CASSETTE		117	X-3365-437-1	FLYWHEEL (A) ASSYLAY (CAPSTAN)	
104	X-3365-441-1	HOLDER (B) ASSY, CASSETTE		118	3-382-859-01	BELT (CAPSTAN A)	
105	3-382-524-01	GEAR (S SIDE REEL)					
				119	3-358-230-01	BELT (A1)	
106	X-3365-559-1	TABLE (T) ASSY, REEL		* 120	3-381-776-01	HOLDER (LED)	
107	3-558-798-01	WASHER, STOPPER		121	3-381-811-01	SCREW (2X18)	
108	X-3365-447-1	GEAR (FF) ASSY		* 122	1-644-686-11	LEAF SW BOARD	
109	3-382-078-01	SPRING (FF), COMPRESSION					
				123	4-919-393-31	DAMPER	
110	3-358-208-01	SPRING (SUPPLY), COMPRESSION		124	3-381-777-01	BRACKET	
111	X-3365-438-1	FLYWHEEL (B) ASSY		125	3-382-860-01	BELT (CAPSTAN B)	
112	3-382-929-01	SPRING (CASSETTE DETENT), LEAF		M901	X-3362-377-1	MOTOR (WH) ASSY	
113	3-354-957-01	JOINT (LOCK LEVER)		M902	A-2004-136-A	MOTOR ASSY, DC (TRIGGER)	
* 114	3-354-953-01	LEVER (LOCK LEVER L)					

REVISED

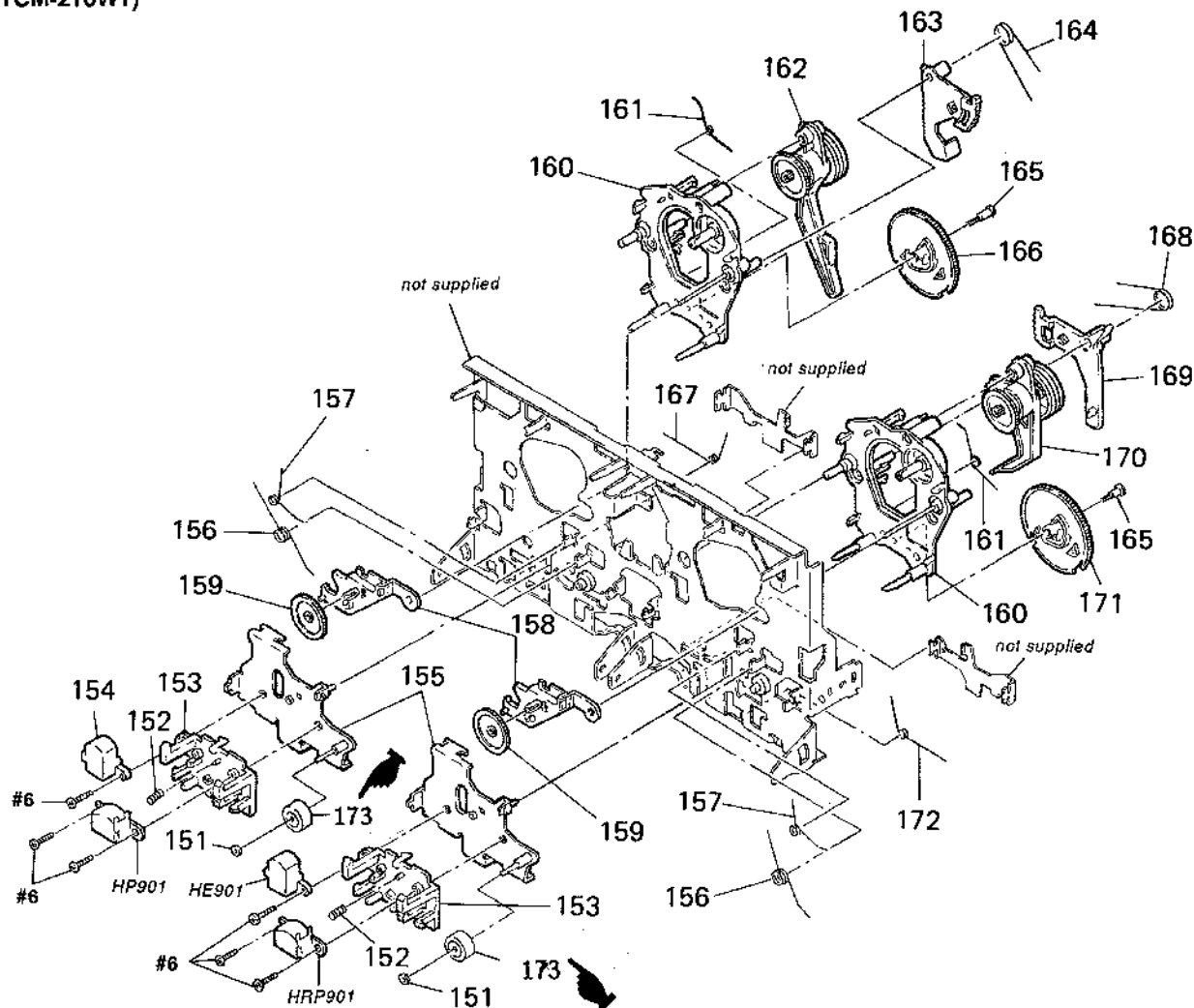
6-4. MECHANISM SECTION-2
(TCM-210W1)

Ref. No.	Part No.	Description	Remark	Ref. No.	Part No.	Description	Remark
151	3-669-465-00	WASHER (1.5), STOPPER		164	3-382-074-01	SPRING (TRIGGER A), TORSION	
152	3-343-484-01	SPRING, COMPRESSION		165	3-381-810-01	SCREW, STEP	
153	3-381-778-01	HOLDER (HEAD)		166	3-381-779-01	CAM (A)	
154	3-319-716-01	GUIDE, TAPE		167	3-383-056-01	SPRING (SLIDER A), TORSION	
* 155	X-3365-439-1	SLIDER (HEAD) ASSY		168	3-382-075-01	SPRING (TRIGGER B), TORSION	
156	3-382-076-01	SPRING (HEAD), TORSION		169	3-381-782-01	LEVER (TRIGGER B)	
157	3-382-077-01	SPRING (TU), TORSION		170	X-3365-445-1	LEVER (FR ARM B) ASSY	
158	3-381-785-01	LEVER (TU)		171	3-381-780-01	CAM (B)	
* 159	3-358-284-01	GEAR (TU GEAR)		172	3-383-057-01	SPRING (SLIDER B), TORSION	
* 160	X-3365-443-1	CHASSIS (M) ASSY		HE901	1-543-673-11	HEAD, MAGNETIC (ERASE)	
161	3-383-498-01	SPRING (CAM), TORSION		HP901	1-543-940-11	HEAD, MAGNETIC (PLAYBACK)	
162	X-3365-444-1	LEVER (FR ARM A) ASSY		HRP901	1-543-319-11	HEAD, MAGNETIC (REC/PB)	
163	3-381-781-01	LEVER (TRIGGER A)		173	*3-355-808-21	PINCH ROLLER	

SECTION 7
ELECTRICAL PARTS LIST

AUDIO

HP

PANEL

POWER SW

POWER TRANSFORMER

SW

NOTE:

- Due to standardization, replacements in the parts list may be different from the parts specified in the diagrams or the components used on the set.
- -XX and -X mean standardized parts, so they may have some difference from the original one.
- RESISTORS
All resistors are in ohms.
METAL: Metal-film resistor.
METAL OXIDE: Metal oxide-film resistor.
F: nonflammable

- Items marked "*" are not stocked since they are seldom required for routine service. Some delay should be anticipated when ordering these items.
- SEMICONDUCTORS
In each case, u: μ , for example:
uA ..: μ A. uPA..: μ PA.
uPB..: μ PB. uPC..: μ PC. uPD..: μ PD.
- CAPACITORS
uF: μ F
- COILS
uH: μ H

When indicating parts by reference number, please include the board.

The components identified by mark Δ or dotted line with mark Δ are critical for safety. Replace only with part number specified.

Les composants identifiés par une marque Δ sont critiques pour la sécurité. Ne les remplacer que par une pièce portant le numéro spécifié.

Ref. No.	Part No.	Description	Remark	Ref. No.	Part No.	Description	Remark
*	A-2006-824-A	AUDIO BOARD, COMPLETE HP BOARD PANEL BOARD POWER SW BOARD POWER TRANSFORMER BOARD SW BOARD *****		C204	1-124-282-00	ELECT 22uF 20% 25V	
				C211	1-162-290-31	CERAMIC 470PF 10% 50V	
				C212	1-124-443-00	ELECT 100uF 20% 10V	
				C213	1-136-157-00	FILM 0.022uF 5% 50V	
				C214	1-124-443-00	ELECT 100uF 20% 10V	
				C215	1-124-282-00	ELECT 22uF 20% 25V	
				C221	1-136-157-00	FILM 0.022uF 5% 50V	
				C227	1-136-439-11	FILM 330PF 5% 630V	
				C231	1-124-927-11	ELECT 4.7uF 20% 100V	
				C232	1-161-374-11	CERAMIC 0.0015uF 20% 50V	
*	3-382-253-01	HOLDER, LED < CAPACITOR >		C234	1-124-907-11	ELECT 10uF 20% 50V	
C101	1-162-290-31	CERAMIC 470PF 10% 50V		C235	1-130-475-00	MYLAR 0.0022uF 5% 50V	
C102	1-136-157-00	FILM 0.022uF 5% 50V		C236	1-130-475-00	MYLAR 0.0022uF 5% 50V	
C103	1-124-443-00	ELECT 100uF 20% 10V		C237	1-136-174-00	FILM 0.56uF 5% 50V	
C104	1-124-282-00	ELECT 22uF 20% 25V		C238	1-136-171-00	FILM 0.33uF 5% 50V	
C111	1-162-290-31	CERAMIC 470PF 10% 50V		C239	1-124-907-11	ELECT 10uF 20% 50V	
C112	1-124-443-00	ELECT 100uF 20% 10V		C240	1-126-176-11	ELECT 220uF 20% 10V	
C113	1-136-157-00	FILM 0.022uF 5% 50V		C242	1-124-927-11	ELECT 4.7uF 20% 100V	
C114	1-124-443-00	ELECT 100uF 20% 10V		C243	1-124-902-00	ELECT 0.47uF 20% 50V	
C115	1-124-282-00	ELECT 22uF 20% 25V		C244	1-124-927-11	ELECT 4.7uF 20% 100V	
C121	1-136-157-00	FILM 0.022uF 5% 50V		C245	1-124-443-00	ELECT 100uF 20% 10V	
C127	1-136-439-11	FILM 330PF 5% 630V		C251	1-124-443-00	ELECT 100uF 20% 10V	
C131	1-124-927-11	ELECT 4.7uF 20% 100V		C271	1-136-433-11	FILM 100PF 5% 630V	
C132	1-161-374-11	CERAMIC 0.0015uF 20% 50V		C272	1-162-284-31	CERAMIC 150PF 10% 50V	
C134	1-124-907-11	ELECT 10uF 20% 50V		C301	1-124-903-11	ELECT 1uF 20% 50V	
C135	1-130-475-00	MYLAR 0.0022uF 5% 50V		C302	1-124-927-11	ELECT 4.7uF 20% 100V	
C136	1-130-475-00	MYLAR 0.0022uF 5% 50V		C401	1-124-903-11	ELECT 1uF 20% 50V	
C137	1-136-174-00	FILM 0.56uF 5% 50V		C402	1-124-927-11	ELECT 4.7uF 20% 100V	
C138	1-136-171-00	FILM 0.33uF 5% 50V		C501	1-124-126-00	ELECT 47uF 20% 10V	
C139	1-124-907-11	ELECT 10uF 20% 50V		C502	1-136-562-11	FILM 0.0082uF 5% 630V	
C140	1-126-176-11	ELECT 220uF 20% 10V		C503	1-124-925-11	ELECT 2.2uF 20% 100V	
C142	1-124-927-11	ELECT 4.7uF 20% 100V		C504	1-130-848-00	FILM 0.0082uF 5% 100V	
C143	1-124-902-00	ELECT 0.47uF 20% 50V		C505	1-136-593-11	FILM 0.0033uF 5% 100V	
C144	1-124-927-11	ELECT 4.7uF 20% 100V		C506	1-136-593-11	FILM 0.0033uF 5% 100V	
C145	1-124-443-00	ELECT 100uF 20% 10V		C507	1-124-902-00	ELECT 0.47uF 20% 50V	
C151	1-124-443-00	ELECT 100uF 20% 10V		C508	1-136-601-11	FILM 0.01uF 5% 630V	
C171	1-136-433-11	FILM 100PF 5% 630V		C509	1-124-927-11	ELECT 4.7uF 20% 100V	
C172	1-162-284-31	CERAMIC 150PF 10% 50V		C601	1-164-159-11	CERAMIC 0.1uF 50V	
C201	1-162-290-31	CERAMIC 470PF 10% 50V		C602	1-164-159-11	CERAMIC 0.1uF 50V	
C202	1-136-157-00	FILM 0.022uF 5% 50V		C701	1-124-564-11	ELECT 4700uF 20% 25V	
C203	1-124-443-00	ELECT 100uF 20% 10V					

AUDIO

HP

PANEL

POWER SW

POWER TRANSFORMER

SW

Ref. No.	Part No.	Description	Remark
C702	1-124-563-11	ELECT 2200uF 20%	25V
C704	1-124-478-11	ELECT 100uF 20%	25V
C705	1-124-473-11	ELECT 1000uF 20%	10V
C706	1-124-473-11	ELECT 1000uF 20%	10V
C707	1-123-382-00	ELECT 3.3uF 20%	100V
C708	1-124-925-11	ELECT 2.2uF 20%	100V
C709	1-124-925-11	ELECT 2.2uF 20%	100V
C710	1-124-472-11	ELECT 470uF 20%	10V
C801	1-161-494-00	CERAMIC 0.022uF	25V
C802	1-124-907-11	ELECT 10uF 20%	50V
C803	1-124-471-00	ELECT 1000uF 20%	6.3V
C805	1-124-443-00	ELECT 100uF 20%	10V
< CONNECTOR >			
* CN101	1-564-506-11	PLUG, CONNECTOR 3P	
* CN111	1-564-509-11	PLUG, CONNECTOR 6P	
* CN201	1-564-505-11	PLUG, CONNECTOR 2P	
* CN301	1-564-339-00	PIN, CONNECTOR 5P	
* CN401	1-564-337-00	PIN, CONNECTOR 3P	
* CN501	1-564-337-00	PIN, CONNECTOR 3P	
* CN601	1-564-509-11	PLUG, CONNECTOR 6P	
* CN602	1-568-832-11	SOCKET, CONNECTOR 13P	
* CN701	1-564-506-11	PLUG, CONNECTOR 3P	
* CN801	1-568-826-11	SOCKET, CONNECTOR 7P	
* CN802	1-568-830-11	SOCKET, CONNECTOR 11P	
< CONNECTOR >			
* CNP801	1-568-826-11	SOCKET, CONNECTOR 7P	
* CNP802	1-568-830-11	SOCKET, CONNECTOR 11P	
< DIODE >			
D101	8-719-304-37	LED SEL4414E-C	
D102	8-719-304-37	LED SEL4414E-C	
D103	8-719-304-37	LED SEL4414E-C	
D104	8-719-304-37	LED SEL4414E-C	
D105	8-719-304-32	LED SEL4214S-C	
D106	8-719-304-32	LED SEL4214S-C	
D107	8-719-304-32	LED SEL4214S-C	
D201	8-719-304-37	LED SEL4414E-C	
D202	8-719-304-37	LED SEL4414E-C	
D203	8-719-304-37	LED SEL4414E-C	
D204	8-719-304-37	LED SEL4414E-C	
D205	8-719-304-32	LED SEL4214S-C	
D206	8-719-304-32	LED SEL4214S-C	
D207	8-719-304-32	LED SEL4214S-C	
D501	8-719-987-63	DIODE 1N4148M	
D502	8-719-987-63	DIODE 1N4148M	
D601	8-719-933-54	DIODE HZS9A2L	
D701	8-719-200-77	DIODE 10E2N	

Ref. No.	Part No.	Description	Remark
D702	8-719-200-77	DIODE 10E2N	
D703	8-719-200-77	DIODE 10E2N	
D704	8-719-200-77	DIODE 10E2N	
D705	8-719-200-77	DIODE 10E2N	
D706	8-719-200-77	DIODE 10E2N	
D707	8-719-933-33	DIODE HZS6A1L	
D708	8-719-933-33	DIODE HZS6A1L	
D709	8-719-987-63	DIODE 1N4148M	
D710	8-719-933-41	DIODE HZS6C3L	
D711	8-719-010-03	DIODE UZ-2. OBS	
D801	8-719-200-77	DIODE 10E2N	
D901	8-719-304-37	LED SEL4414E-C	
D902	8-719-304-37	LED SEL4414E-C	
D903	8-719-312-13	LED SEL4914A-CD	
D904	8-719-304-32	LED SEL4214S-C	
D905	8-719-304-32	LED SEL4214S-C	
D906	8-719-304-32	LED SEL4214S-C	
< IC >			
IC101	8-759-111-44	IC uPC4570C-1	
IC102	8-759-111-44	IC uPC4570C-1	
IC103	8-759-140-53	IC UPD4053BC	
IC104	8-752-059-55	IC CXA1331S	
IC105	8-752-055-62	IC CXA1579P	
IC106	8-759-634-51	IC M5218AP	
IC107	8-759-079-42	IC uPC1330HA-NA	
IC301	8-759-912-79	IC 1R2E02	
IC401	8-759-912-79	IC 1R2E02	
IC601	8-759-822-09	IC LB1641	
IC701	8-759-745-58	IC RC4558P	
IC801	8-759-073-43	IC M37471M2-118SP	
IC810	8-741-100-48	IC SBX1610-59	
< JACK >			
J501	1-507-796-71	JACK, LARGE TYPE (HEADPHONES)	
J601	1-565-258-11	JACK, PIN 4P (LINE)	
< COIL >			
L101	1-410-781-11	INDUCTOR 33mH	
L201	1-410-781-11	INDUCTOR 33mH	
< FILTER >			
LPF131	1-239-355-11	FILTER, LOW PASS	
LPF231	1-239-355-11	FILTER, LOW PASS	

AUDIO

HP

PANEL

POWER SW

POWER TRANSFORMER

SW

Ref. No.	Part No.	Description	Remark	Ref. No.	Part No.	Description	Remark
< TRANSISTOR >				R116	1-249-409-11	CARBON	220 5% 1/4W
Q101	8-729-900-80	TRANSISTOR	DTC114ES	R121	1-247-838-00	CARBON	2K 5% 1/4W
Q104	8-729-922-37	TRANSISTOR	2SD2144S-UVW	R122	1-247-842-11	CARBON	3K 5% 1/4W
Q105	8-729-142-46	TRANSISTOR	2SC2001-LK	R123	1-247-887-00	CARBON	220K 5% 1/4W
Q201	8-729-900-80	TRANSISTOR	DTC114ES	R131	1-249-417-11	CARBON	1K 5% 1/4W
Q204	8-729-922-37	TRANSISTOR	2SD2144S-UVW	R132	1-249-423-11	CARBON	3. 3K 5% 1/4W
Q205	8-729-142-46	TRANSISTOR	2SC2001-LK	R133	1-249-428-11	CARBON	8. 2K 5% 1/4W
Q502	8-729-142-46	TRANSISTOR	2SC2001-LK	R134	1-249-421-11	CARBON	2. 2K 5% 1/4W
Q503	8-729-119-76	TRANSISTOR	2SA1175-HFE	R135	1-247-864-11	CARBON	24K 5% 1/4W
Q504	8-729-119-76	TRANSISTOR	2SA1175-HFE	R136	1-249-414-11	CARBON	560 5% 1/4W
Q505	8-729-900-61	TRANSISTOR	DTA114ES	R137	1-260-081-81	CARBON	33 5% 1/2W
Q506	8-729-119-76	TRANSISTOR	2SA1175-HFE	R141	1-249-429-11	CARBON	10K 5% 1/4W
Q507	8-729-900-61	TRANSISTOR	DTA114ES	R151	1-249-421-11	CARBON	2. 2K 5% 1/4W
Q511	8-729-900-89	TRANSISTOR	DTC144ES	R152	1-249-425-11	CARBON	4. 7K 5% 1/4W
Q601	8-729-900-65	TRANSISTOR	DTA144ES	R153	1-249-428-11	CARBON	8. 2K 5% 1/4W
Q602	8-729-900-89	TRANSISTOR	DTC144ES	R154	1-249-429-11	CARBON	10K 5% 1/4W
Q603	8-729-900-61	TRANSISTOR	DTA114ES	R155	1-249-433-11	CARBON	22K 5% 1/4W
Q604	8-729-801-93	TRANSISTOR	2SD1387-3	R156	1-247-868-11	CARBON	36K 5% 1/4W
Q605	8-729-119-76	TRANSISTOR	2SA1175-HFE	R157	1-249-409-11	CARBON	220 5% 1/4W
Q606	8-729-620-05	TRANSISTOR	2SC2603-EF	R161	1-249-417-11	CARBON	1K 5% 1/4W
Q701	8-729-141-83	TRANSISTOR	2SB1094-LK	R162	1-249-433-11	CARBON	22K 5% 1/4W
Q702	8-729-209-15	TRANSISTOR	2SD2012	R171	1-249-430-11	CARBON	12K 5% 1/4W
Q703	8-729-900-74	TRANSISTOR	DTC143TS	R201	1-247-899-11	CARBON	680K 5% 1/4W
Q704	8-729-900-74	TRANSISTOR	DTC143TS	R202	1-249-405-11	CARBON	100 5% 1/4W
Q705	8-729-620-05	TRANSISTOR	2SC2603-EF	R203	1-249-426-11	CARBON	5. 6K 5% 1/4W
Q706	8-729-209-15	TRANSISTOR	2SD2012	R204	1-247-882-11	CARBON	130K 5% 1/4W
Q707	8-729-900-89	TRANSISTOR	DTC144ES	R205	1-249-409-11	CARBON	220 5% 1/4W
Q801	8-729-900-61	TRANSISTOR	DTA114ES	R211	1-247-889-00	CARBON	270K 5% 1/4W
Q802	8-729-900-61	TRANSISTOR	DTA114ES	R212	1-249-433-11	CARBON	22K 5% 1/4W
Q804	8-729-900-61	TRANSISTOR	DTA114ES	R213	1-249-405-11	CARBON	100 5% 1/4W
Q805	8-729-620-05	TRANSISTOR	2SC2603-EF	R214	1-249-426-11	CARBON	5. 6K 5% 1/4W
Q806	8-729-620-05	TRANSISTOR	2SC2603-EF	R215	1-247-882-11	CARBON	130K 5% 1/4W
Q807	8-729-900-80	TRANSISTOR	DTC114ES	R216	1-249-409-11	CARBON	220 5% 1/4W
Q901	8-729-119-76	TRANSISTOR	2SA1175-HFE	R221	1-247-838-00	CARBON	2K 5% 1/4W
Q902	8-729-119-76	TRANSISTOR	2SA1175-HFE	R222	1-247-842-11	CARBON	3K 5% 1/4W
Q903	8-729-119-76	TRANSISTOR	2SA1175-HFE	R223	1-247-887-00	CARBON	220K 5% 1/4W
< RESISTOR >				R231	1-249-417-11	CARBON	1K 5% 1/4W
R101	1-247-899-11	CARBON	680K 5% 1/4W	R232	1-249-423-11	CARBON	3. 3K 5% 1/4W
R102	1-249-405-11	CARBON	100 5% 1/4W	R233	1-249-428-11	CARBON	8. 2K 5% 1/4W
R103	1-249-426-11	CARBON	5. 6K 5% 1/4W	R234	1-249-421-11	CARBON	2. 2K 5% 1/4W
R104	1-247-882-11	CARBON	130K 5% 1/4W	R235	1-247-864-11	CARBON	24K 5% 1/4W
R105	1-249-409-11	CARBON	220 5% 1/4W	R236	1-249-414-11	CARBON	560 5% 1/4W
R111	1-247-889-00	CARBON	270K 5% 1/4W	R237	1-260-081-81	CARBON	33 5% 1/2W
R112	1-249-433-11	CARBON	22K 5% 1/4W	R241	1-249-429-11	CARBON	10K 5% 1/4W
R113	1-249-405-11	CARBON	100 5% 1/4W	R251	1-249-421-11	CARBON	2. 2K 5% 1/4W
R114	1-249-426-11	CARBON	5. 6K 5% 1/4W	R252	1-249-425-11	CARBON	4. 7K 5% 1/4W
R115	1-247-882-11	CARBON	130K 5% 1/4W	R253	1-249-428-11	CARBON	8. 2K 5% 1/4W
				R254	1-249-429-11	CARBON	10K 5% 1/4W
				R255	1-249-433-11	CARBON	22K 5% 1/4W

AUDIO	HP	PANEL	POWER SW	POWER TRANSFORMER	SW
--------------	-----------	--------------	-----------------	--------------------------	-----------

Ref. No.	Part No.	Description		Remark	Ref. No.	Part No.	Description		Remark
R256	1-247-868-11	CARBON	36K 5%	1/4W	R6D1	1-249-417-11	CARBON	1K 5%	1/4W
R257	1-249-409-11	CARBON	220 5%	1/4W	R603	1-249-414-11	CARBON	560 5%	1/4W
R261	1-249-417-11	CARBON	1K 5%	1/4W	R604	1-249-425-11	CARBON	4.7K 5%	1/4W
R262	1-249-433-11	CARBON	22K 5%	1/4W	R605	1-249-408-11	CARBON	180 5%	1/4W
R271	1-249-430-11	CARBON	12K 5%	1/4W	R607	1-249-423-11	CARBON	3.3K 5%	1/4W
R301	1-249-425-11	CARBON	4.7K 5%	1/4W	R608	1-249-425-11	CARBON	4.7K 5%	1/4W
R302	1-249-441-11	CARBON	100K 5%	1/4W	R701	1-249-433-11	CARBON	22K 5%	1/4W
R303	1-249-441-11	CARBON	100K 5%	1/4W	R702	1-249-420-11	CARBON	1.8K 5%	1/4W
R304	1-249-433-11	CARBON	22K 5%	1/4W	R703	1-249-427-11	CARBON	6.8K 5%	1/4W
R401	1-249-425-11	CARBON	4.7K 5%	1/4W	R704	1-249-419-11	CARBON	1.5K 5%	1/4W
R402	1-249-441-11	CARBON	100K 5%	1/4W	R705	1-249-419-11	CARBON	1.5K 5%	1/4W
R403	1-249-441-11	CARBON	100K 5%	1/4W	R706	1-249-429-11	CARBON	10K 5%	1/4W
R404	1-249-433-11	CARBON	22K 5%	1/4W	R707	1-249-427-11	CARBON	6.8K 5%	1/4W
R501	1-249-429-11	CARBON	10K 5%	1/4W	R708	1-249-409-11	CARBON	220 5%	1/4W
R502	1-249-417-11	CARBON	1K 5%	1/4W	R709	1-249-417-11	CARBON	1K 5%	1/4W
R503	1-215-455-00	METAL	27K 1%	1/6W	R710	1-249-427-11	CARBON	6.8K 5%	1/4W
R504	1-249-415-11	CARBON	680 5%	1/4W	R711	1-249-420-11	CARBON	1.8K 5%	1/4W
R505	1-215-455-00	METAL	27K 1%	1/6W	R712	1-249-437-11	CARBON	47K 5%	1/4W
R506	1-249-417-11	CARBON	1K 5%	1/4W	R713	1-249-425-11	CARBON	4.7K 5%	1/4W
R507	1-249-417-11	CARBON	1K 5%	1/4W	R801	1-249-429-11	CARBON	10K 5%	1/4W
R510	1-247-862-11	CARBON	20K 5%	1/4W	R802	1-249-429-11	CARBON	10K 5%	1/4W
R511	1-249-429-11	CARBON	10K 5%	1/4W	R803	1-249-429-11	CARBON	10K 5%	1/4W
R512	1-247-846-11	CARBON	4.3K 5%	1/4W	R804	1-249-437-11	CARBON	47K 5%	1/4W
R513	1-249-429-11	CARBON	10K 5%	1/4W	R805	1-249-437-11	CARBON	47K 5%	1/4W
R514	1-249-429-11	CARBON	10K 5%	1/4W	R806	1-247-903-00	CARBON	1M 5%	1/4W
R515	1-249-429-11	CARBON	10K 5%	1/4W	R807	1-249-425-11	CARBON	4.7K 5%	1/4W
△R521	1-212-849-00	FUSIBLE	4.7 5%	1/4W F	R808	1-249-425-11	CARBON	4.7K 5%	1/4W
△R522	1-212-849-00	FUSIBLE	4.7 5%	1/4W F	R809	1-249-429-11	CARBON	10K 5%	1/4W
R523	1-249-436-11	CARBON	39K 5%	1/4W	R810	1-249-429-11	CARBON	10K 5%	1/4W
R524	1-249-436-11	CARBON	39K 5%	1/4W	R811	1-249-429-11	CARBON	10K 5%	1/4W
R525	1-249-429-11	CARBON	10K 5%	1/4W	R812	1-249-429-11	CARBON	10K 5%	1/4W
R526	1-247-858-11	CARBON	13K 5%	1/4W	R813	1-249-429-11	CARBON	10K 5%	1/4W
R527	1-249-433-11	CARBON	22K 5%	1/4W	R814	1-249-433-11	CARBON	22K 5%	1/4W
R528	1-249-429-11	CARBON	10K 5%	1/4W	R815	1-249-429-11	CARBON	10K 5%	1/4W
R529	1-249-433-11	CARBON	22K 5%	1/4W	R816	1-249-428-11	CARBON	8.2K 5%	1/4W
R530	1-249-421-11	CARBON	2.2K 5%	1/4W	R817	1-247-836-11	CARBON	1.6K 5%	1/4W
R531	1-249-433-11	CARBON	22K 5%	1/4W	R818	1-249-411-11	CARBON	330 5%	1/4W
R532	1-249-433-11	CARBON	22K 5%	1/4W	R820	1-249-429-11	CARBON	10K 5%	1/4W
R551	1-249-419-11	CARBON	1.5K 5%	1/4W	R821	1-249-433-11	CARBON	22K 5%	1/4W
R552	1-249-421-11	CARBON	2.2K 5%	1/4W	R822	1-249-417-11	CARBON	1K 5%	1/4W
R553	1-249-424-11	CARBON	3.9K 5%	1/4W	R823	1-249-417-11	CARBON	1K 5%	1/4W
R554	1-249-426-11	CARBON	5.6K 5%	1/4W	R824	1-249-417-11	CARBON	1K 5%	1/4W
R555	1-249-430-11	CARBON	12K 5%	1/4W	R825	1-249-417-11	CARBON	1K 5%	1/4W
R556	1-249-436-11	CARBON	39K 5%	1/4W	R826	1-249-417-11	CARBON	1K 5%	1/4W
R557	1-249-419-11	CARBON	1.5K 5%	1/4W	R827	1-249-417-11	CARBON	1K 5%	1/4W
R558	1-249-421-11	CARBON	2.2K 5%	1/4W	R828	1-249-417-11	CARBON	1K 5%	1/4W
R559	1-249-424-11	CARBON	3.9K 5%	1/4W	R829	1-249-429-11	CARBON	10K 5%	1/4W
R560	1-249-426-11	CARBON	5.6K 5%	1/4W					
R561	1-249-430-11	CARBON	12K 5%	1/4W					

The components identified by mark △ or dotted line with mark △ are critical for safety. Replace only with part number specified.

les composants identifiés par une marque △ sont critiques pour la sécurité. Ne les remplacer que par une pièce portant le numéro spécifié.

AUDIO HP PANEL

POWER SW

POWER TRANSFORMER

SW

LEAF SW

MOTOR

Ref. No.	Part No.	Description	Remark
R901	1-249-409-11	CARBON 220 5% 1/4W	
R902	1-249-409-11	CARBON 220 5% 1/4W	
R903	1-249-410-11	CARBON 270 5% 1/4W	
R904	1-249-411-11	CARBON 330 5% 1/4W	
< VARIABLE RESISTOR >			
RV101	1-241-627-11	RES, ADJ. CARBON 1K	
RV102	1-241-767-21	RES, ADJ. CERMET 100K	
RV103	1-241-630-11	RES, ADJ. CARBON 10K	
RV111	1-241-627-11	RES, ADJ. CARBON 1K	
RV201	1-241-627-11	RES, ADJ. CARBON 1K	
RV202	1-241-767-21	RES, ADJ. CERMET 100K	
RV203	1-241-630-11	RES, ADJ. CARBON 10K	
RV211	1-241-627-11	RES, ADJ. CARBON 1K	
RV601	1-241-630-11	RES, ADJ. CARBON 10K	
RV602	1-241-629-11	RES, ADJ. CARBON 4.7K	
RV901	1-241-981-11	RES, VAR. CARBON 20K/20K (REC LEVEL)	
< SWITCH >			
S501	1-554-303-21	SWITCH, TACTILE (■ (DECK A))	
S502	1-554-303-21	SWITCH, TACTILE (▷ (DECK A))	
S503	1-554-303-21	SWITCH, TACTILE (◀◀ (DECK B))	
S504	1-554-303-21	SWITCH, TACTILE (▶▶ (DECK B))	
S505	1-554-303-21	SWITCH, TACTILE (● (DECK B))	
S506	1-554-303-21	SWITCH, TACTILE (HIGH SPEED) (SYNCHRO DUBBING-START ■ B)	
S507	1-554-303-21	SWITCH, TACTILE (NORMAL SPEED) (SYNCHRO DUBBING-START ■ B)	
S508	1-554-303-21	SWITCH, TACTILE (■ (DECK B))	
S509	1-554-303-21	SWITCH, TACTILE (■ PAUSE (DECK B))	
S510	1-554-303-21	SWITCH, TACTILE (▷ (DECK B))	
S511	1-554-303-21	SWITCH, TACTILE (● REC MUTE (DECK B))	
S512	1-554-303-21	SWITCH, TACTILE (◀◀ (DECK A))	
S513	1-554-303-21	SWITCH, TACTILE (▶▶ (DECK A))	
S521	1-554-118-00	SWITCH, PUSH (1 KEY) (POWER)	
S901	1-571-908-11	SWITCH, SLIDE (DOLBY NR)	
< TRANSFORMER >			
T501	1-433-400-11	TRANSFORMER, BIAS OSCILLATION	
< TEST PIN >			
* TP801	1-564-505-11	PLUG, CONNECTOR 2P	

Ref. No.	Part No.	Description	Remark
< VIBRATOR >			
X801	1-577-358-21	VIBRATOR, CERAMIC (4MHz)	

*	1-644-686-11	LEAF SW BOARD MOTOR BOARD *****	
*	3-381-776-01	HOLDER (LED)	
< CAPACITOR >			
C1001	1-164-159-11	CERAMIC 0.1uF 50V	
< CONNECTOR >			
+ CN1001	1-568-856-11	SOCKET, CONNECTOR 13P	
* CN1002	1-564-517-11	PLUG, CONNECTOR 2P	
< TRANSISTOR >			
Q1001	8-719-939-11	DIODE GP-2S09-B	
Q1002	8-719-939-11	DIODE GP-2S09-B	
< RESISTOR >			
R1001	1-249-409-11	CARBON 220 5% 1/4W	
R1002	1-249-409-11	CARBON 220 5% 1/4W	
< SWITCH >			
S1001	1-572-202-11	SWITCH, LEAF (HALF (DECK A))	
S1002	1-572-125-11	SWITCH, LEAF (70/120u (DECK A))	
S1003	1-572-125-11	SWITCH, LEAF (REC (DECK B))	
S1004	1-572-125-11	SWITCH, LEAF (70/120u (DECK B))	
S1005	1-572-202-11	SWITCH, LEAF (HALF (DECK B))	
S1006	1-572-125-11	SWITCH, LEAF (METAL (DECK B))	
S1007	1-692-193-11	SWITCH, PUSH (1 KEY) (PLAY/STOP (DECK A))	
S1008	1-692-193-11	SWITCH, PUSH (1 KEY) (PLAY/STOP (DECK B))	

MISCELLANEOUS *****			
1	1-534-517-00	WIRE (FLAT TYPE) (13 CORE)	
5	1-690-420-11	WIRE, FLAT TYPE (7 CORE)	
6	1-575-784-11	WIRE (FLAT TYPE) (11 CORE)	
△9	1-569-007-11	ADAPTER, CONVERSION 2P (E)	
△10	1-551-188-XX	CORD, POWER (E)	
△10	1-555-795-00	CORD, POWER, EULO PLUG (AEP)	
△10	1-558-945-11	CORD, POWER (POLAR SPT-1) (US, Canadian)	
△10	1-559-912-11	CORD, POWER (Australian)	

<p>The components identified by mark △ or dotted line with mark △ are critical for safety. Replace only with part number specified.</p>	<p>Les composants identifiés par une marque △ sont critiques pour la sécurité. Ne les remplacer que par une pièce portant le numéro spécifié.</p>
---	---

Ref. No.	Part No.	Description	Remark
59	1-548-596-41	COUNTER, TAPE (MIDDLE TYPE)	
HE901	1-543-673-11	HEAD, MAGNETIC (ERASE)	
HP901	1-543-940-11	HEAD, MAGNETIC (PLAYBACK)	
HRP901	1-543-319-11	HEAD, MAGNETIC (REC/PB)	
M901	X-3382-377-1	MOTOR (WH) ASSY	
M902	A-2004-136-A	MOTOR ASSY, DC (TRIGGER)	
△S902	1-692-155-11	SELECTOR, POWER VOLTAGE (E)	
△T901	1-450-990-11	TRANSFORMER, POWER (US, Canadian)	
△T901	1-450-991-11	TRANSFORMER, POWER (AEP, Australian)	
△T901	1-450-992-11	TRANSFORMER, POWER (E)	

 ACCESSORIES & PACKING MATERIALS

	1-558-271-11	CORD, CONNECTION
	1-558-271-11	CORD, CONNECTION
*	3-380-106-01	CUSHION
*	3-380-107-01	INDIVIDUAL CARTON (W32)
*	3-380-107-11	INDIVIDUAL CARTON (W290)
	3-755-498-11	MANUAL, INSTRUCTION (ENGLISH/FRENCH/ SPANISH/PORTUGUESE) (Canadian, AEP, E)
	3-755-498-21	MANUAL, INSTRUCTION (ENGLISH) (US, Australian)
	3-755-498-41	MANUAL, INSTRUCTION (GERMAN/DUTCH/ SWEDISH/ITALIAN) (AEP)
	3-755-498-51	MANUAL, INSTRUCTION (CHINESE) (E)

 HARDWARE LIST

#1	7-682-548-09	SCREW +BVTT 3X8 (S)
#2	7-682-547-04	SCREW +BVTT 3X6 (S)
#3	7-621-849-00	SCREW (BV/RING)
#4	7-685-646-79	SCREW +BVTP 3X8 TYPE2 N-S
#5	7-685-134-19	SCREW (+ PTPWH) (2.6X8)
#6	7-621-772-40	SCREW, AZIMUTH
#7	7-623-921-01	RING, RETAINING, CAPSTAN
#8	7-621-255-25	SCREW +BVTT 2X4 (S)
#9	7-621-770-XX	SCREW +BVTT 2.6X8 (S)
#10	7-621-770-67	SCREW +BVTT 2.6X6 (S)
#11	7-621-775-10	SCREW +B 2.6X4
#12	7-621-775-00	SCREW +B 2.6X3

The components identified by mark △ or dotted line with mark △ are critical for safety. Replace only with part number specified.

Les composants identifiés par une marque △ sont critiques pour la sécurité. Ne les remplacer que par une pièce portant le numéro spécifié.

