

TC-V925E

SERVICE MANUAL

AEP Model
UK Model

TC-V925E is the
cassette deck
section in LBT-V925CD.

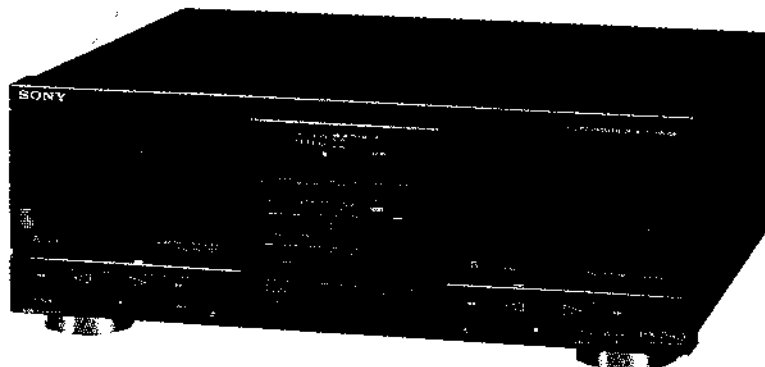

| | | |
|------------------------------------|---------|-------------|
| Model Name Using Similar Mechanism | TC-V901 | |
| Tape Transport Mechanism Type | DECK A | TCM-170RA4 |
| | DECK B | TCM-170RB10 |

SPECIFICATIONS

| | |
|--------------------|---|
| Recording system | 4-track, 2-channel stereo |
| Frequency response | DOLBY NR OFF (DIN) With TYPE IV cassette (SONY METAL-ES) 30 to 15,000 Hz ± 3 dB With TYPE II cassette (Sony UX-S) 30 to 14,000 Hz ± 3 dB With TYPE I cassette (Sony HF-S) 30 to 13,000 Hz ± 3 dB |
| Wow and flutter | ± 0.2 % (DIN) |
| AC outlet | 1 unswitched, max. 100 W |
| Dimensions | 355 × 133 × 308 mm (w/h/d) (14 × 5 ¹ / ₄ × 12 ¹ / ₈ inches) Incl. projecting parts and controls |
| Weight | Approx. 4.6 kg (10 lb 3 oz) |

Dolby noise reduction manufactured under license from
Dolby Laboratories Licensing Corporation.
"DOLBY" and the double-D symbol  are trademarks of
Dolby Laboratories Licensing Corporation.



STEREO CASSETTE DECK
SONY®

SECTION 1 GENERAL

TABLE OF CONTENTS

| Section | Title | Page |
|---------------------------------------|-------|------|
| Specifications | | 1 |
| Model Identification | | 2 |
| 1. GENERAL | | |
| Location and Function of Controls | | 2 |
| 2. DISASSEMBLY | | 3 |
| 3. ADJUSTMENTS | | |
| 3-1. Mechanical Adjustments | | 5 |
| 3-2. Electrical Adjustments | | 6 |
| 4. DIAGRAMS | | |
| 4-1. M50964-210SP (IC803) | | 9 |
| 4-2. Printed Wiring Boards | | 12 |
| 4-3. Schematic Diagram | | 17 |
| 4-4. Schematic Diagram (HX-PRO Board) | | 22 |
| 5. EXPLODED VIEWS | | 24 |
| 6. ELECTRICAL PARTS LIST | | 28 |

MODEL IDENTIFICATION (Specification Label)

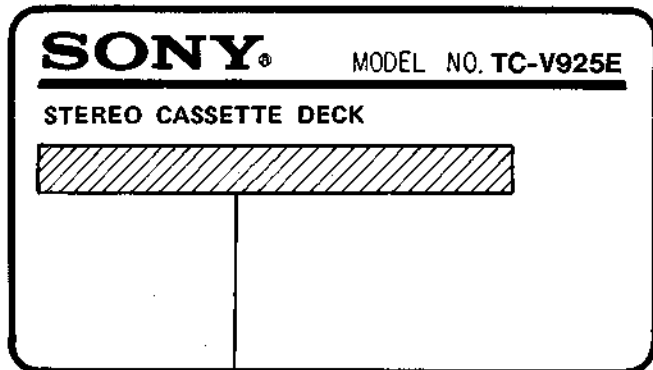

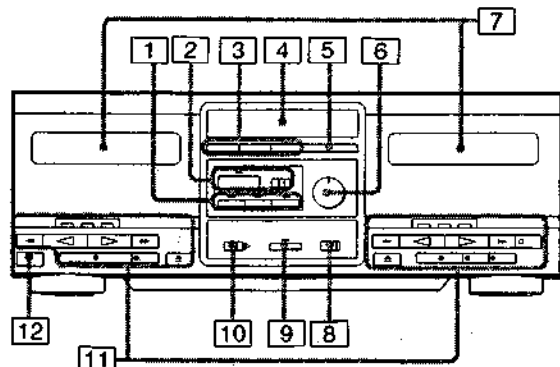

AEP, Italian model: AC 220V~50/60Hz 28W
UK model: AC 240V~50/60Hz 28W



- 1** SYNCHRO (synchronized) DUBBING and AUTO (automatic) PAUSE buttons and indicators
- 2** AUTO CD SYNCHRO (automatic CD synchronization) button and mode selector
- 3** Counter setting buttons
- 4** Display window
- 5** CCLA (Computer Controlled Level Adjustment) button
- 6** REC (recording) LEVEL control
- 7** Cassette holders
- 8** DOLBY NR (Noise Reduction) switch
- 9** AMS (Automatic Music Sensor)/BLANK SKIP button
- 10** DIRECTION MODE selector
- 11** Tape operation buttons and direction mode indicators
 ◀◀: Leftward fast winding, ▶▶: Rightward fast winding,
 ◀: Reverse play, ▶: Forward play, ■: Stop, ||| PAUSE: Pause,
 ○ REC MUTE: Recording mute (deck B only),
 ● REC: Recording (deck B only), ▲: Eject
- 12** POWER switch

SAFETY-RELATED COMPONENT WARNING!!

COMPONENTS IDENTIFIED BY MARK  OR DOTTED LINE WITH MARK  ON THE SCHEMATIC DIAGRAMS AND IN THE PARTS LIST ARE CRITICAL TO SAFE OPERATION. REPLACE THESE COMPONENTS WITH SONY PARTS WHOSE PART NUMBERS APPEAR AS SHOWN IN THIS MANUAL OR IN SUPPLEMENTS PUBLISHED BY SONY.

SECTION 2 DISASSEMBLY

Note: Follow the disassembly procedure in the numerical order given.

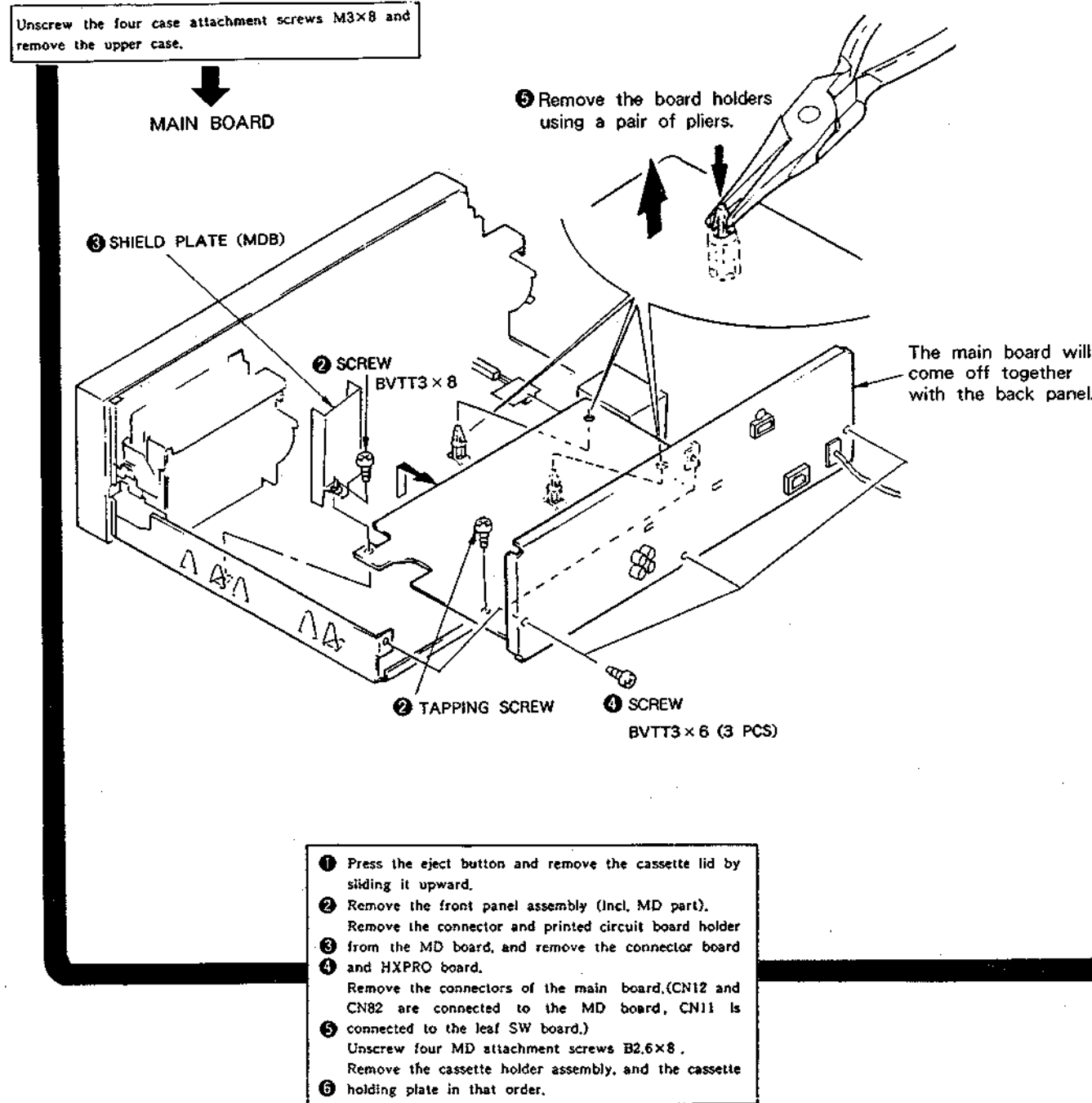

MOTOR Ass'y

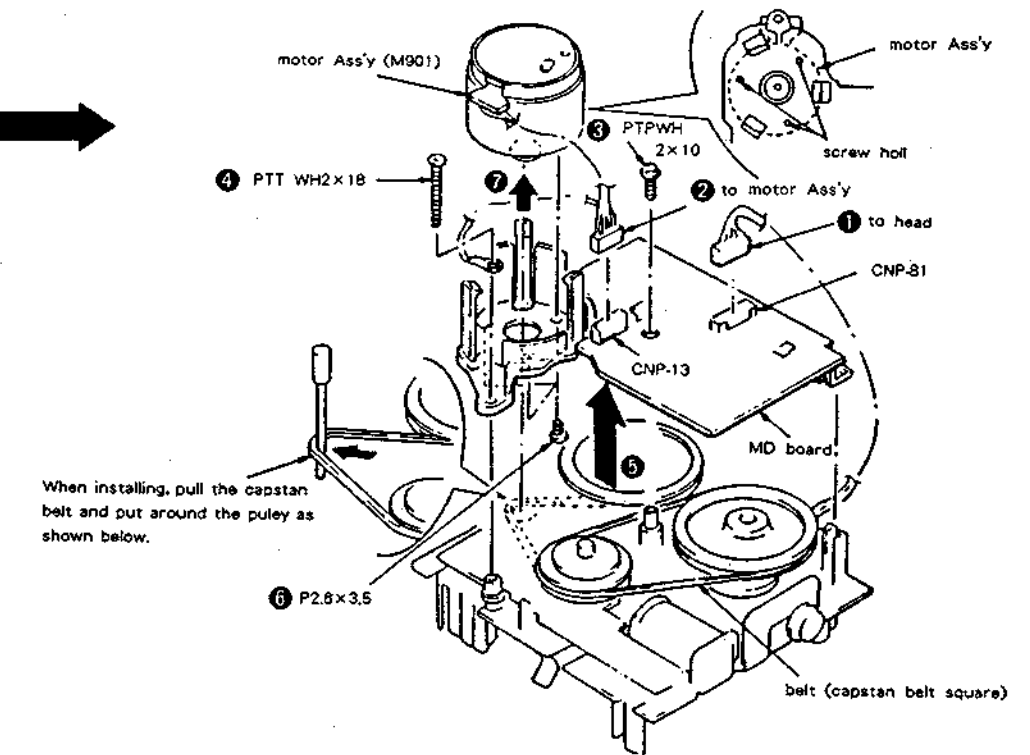

HEAD Ass'y

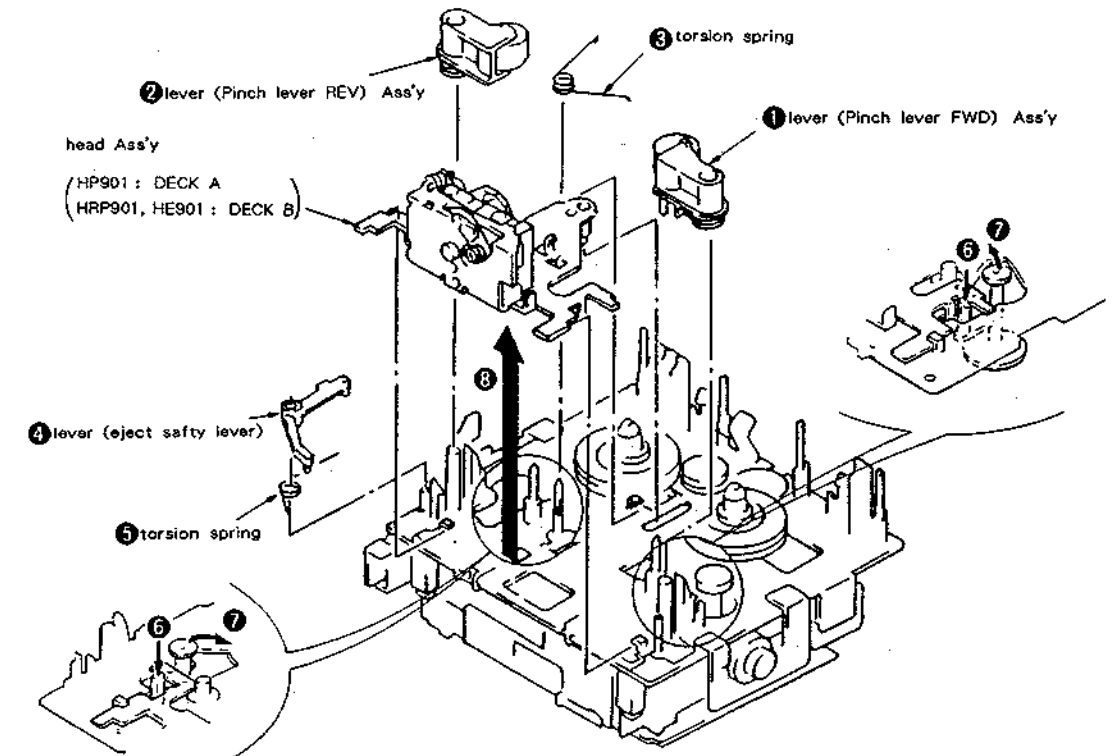

SECTION 3 ADJUSTMENTS

3-1. MECHANICAL ADJUSTMENT

PRECAUTION

- Clean the following parts with a denatured-alcohol-moistened swab:

| | |
|----------------------|--------------|
| record/playback head | pinch roller |
| erase head | rubber belts |
| capstan | idler |
- Demagnetize the record/playback head with a head demagnetizer.
- Do not use a magnetized screwdriver for the adjustments.
- The adjustments should be performed in the rated power supply voltage unless otherwise noted.

Torque Measurement

| Torque | Torque Meter | Meter Reading |
|------------------|--------------|--|
| FWD | CQ-102C | 27 to 75 g*cm (0.38 to 1.04 oz*inch) |
| FWD Back Tension | CQ-102C | 1 to 10 g*cm (0.014 to 0.13 oz*inch) |
| REV | CQ-102RC | 27 to 75 g*cm (0.38 to 1.04 oz*inch) |
| REV Back Tension | CQ-102RC | 1 to 10 g*cm (0.014 to 0.13 oz*inch) |
| FF, REW | CQ-201B | 95 to 165 g*cm (1.33 to 2.29 oz*inch) |

3-2. ELECTRICAL ADJUSTMENTS

Note: The adjustment should be performed in the order given in the service manual. As a rule, adjustment about playback should be performed before adjustment about recording.

The adjustments should be performed for both L-CH and R-CH.

- Switches and controls should be set as follows unless otherwise specified.

DOLBY NR switch : OFF

DIRECTION MODE switch : \equiv

- Standard Record:

Deliver the standard input signal level to the input jack and set the REC LEVEL control to obtain the standard output signal level.

Record Mode

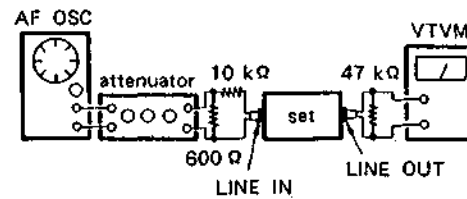

Standard Input Level

| | |
|------------------|-------------------|
| input terminal | LINE IN |
| source impedance | 10 kΩ |
| input level | 0.25 V (- 10 dB) |

Standard Output Level

| | |
|-----------------|------------------|
| output terminal | LINE OUT |
| load impedance | 47 kΩ |
| output level | 0.44 V (- 5 dB) |

Test tape

| Type | Signal | User for |
|----------|-----------------|-----------------------|
| P-4-A100 | 10 kHz, - 10 dB | Azimuth Adjustment |
| P-4-L300 | 315 Hz, 0 dB | PB Level Adjustment |
| WS-48B | 3 kHz, 0 dB | Tape Speed Adjustment |

Record/Playback Head Azimuth Adjustment

DECK A DECK B

Procedure:

- Mode: FWD playback

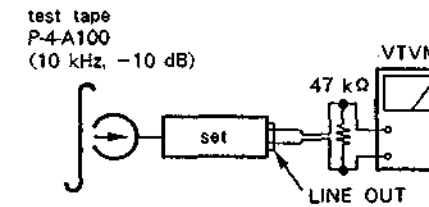

- Turn the adjustment screw for the maximum output levels. If these levels do not match, turn the adjustment screw until both of output levels match together within 1dB.

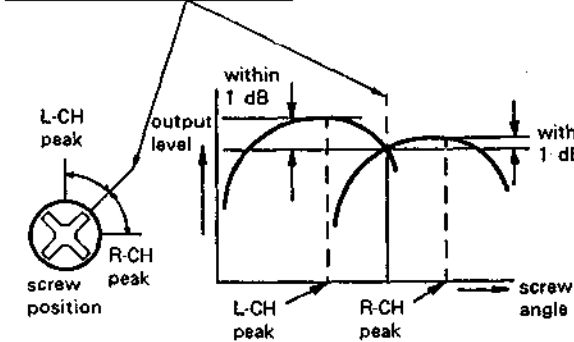

- Phase Check
Mode: playback

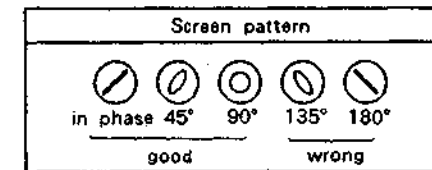
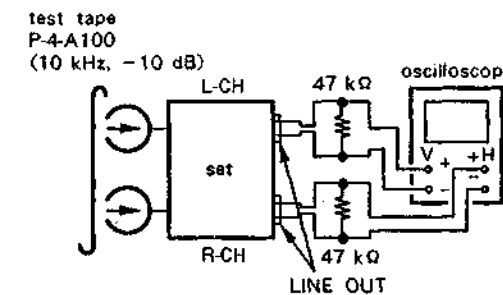

- Set in the REV mode and repeat the step 1 - 3.
- After the adjustment, lock the screws with locking compound.

Adjustment Location: record/playback head

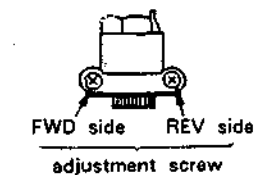

Tape Speed Adjustment DECK A DECK B

Perform high speed adjustment before normal speed adjustment.

Procedure:

Mode: FWD playback

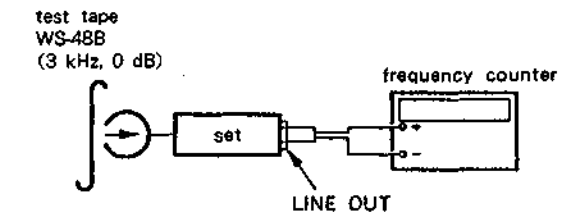

[High Speed Adjustment]

- Short test pin TPI on main board.
- Put the set to FWD playback state.
- Press and keep on pressing HIGH SPEED DUBBING switch (S802 on FL board).
- On this time, adjust with the semi-fixed variable resistors (H) on the rear side of M901A (Deck A) and M901B (Deck B) so that the reading on the frequency counter becomes the adjustment limits.
- After adjustment, release the short on TPI.

[Normal Speed Adjustment]

- Put the set to FWD playback state.
- On this time, adjust with the semi-fixed variable resistors (L) on the rear side of M901A (Deck A) and M901B (Deck B) so that the reading on the frequency counter becomes the adjustment limits.

Adjustment Limits:

| Speed | Frequency Counter |
|--------|-------------------|
| high | 5,960 ± 60 Hz |
| normal | 2,980 ± 30 Hz |

Frequency difference between the beginning and the end of the tape should be within 3%.
Frequency difference between Deck A and Deck B the beginning of the tape should be within 1.5%.

Adjustment Location:

Deck A: motor (M901A) rear side
Deck B: motor (M901B) rear side

Playback Level Adjustment **DECK A** **DECK B**

Procedure:

Mode: playback

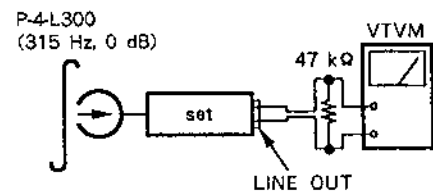

Adjust Deck A: RV41A (L-CH), RV61A (R-CH) and Deck B: RV41B (L-CH), RV61B (R-CH) so that the VTVM reading becomes the adjustment limits below.

Adjustment Limits:

LINE OUT level: -5 ± 1.5 dB (0.37 - 0.51V)

Level difference between channels: less than 1 dB.

Check that the LINE OUT level does not change in playback mode while changing the mode from playback to stop several times.

Adjustment Location: MD (A), B) board

Record Bias Step-Up Adjustment **DECK B**

This adjustment should be performed when replacing the head assy or the bias oscillating transformer (T51, T71), or DOLBY HX PRO IC (IC91).

Procedure:

() : R-CH

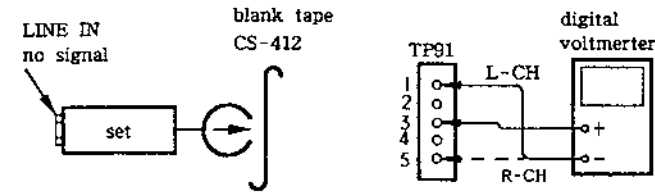

1. Connect the oscilloscope to test point TP91.
2. Set RV42 (RV62) to mechanical center.
3. Set to FWD record mode.
4. Adjust T51 (T71) so that the digital voltmeter reading becomes 40 mV.

Adjustment Location: HX PRO board

Record Bias Adjustment **DECK B**

Setting:

- REC LEVEL control: standard record (See page 5.)
- Short test pin TP1 on main board.

Procedure:

1. Mode: record

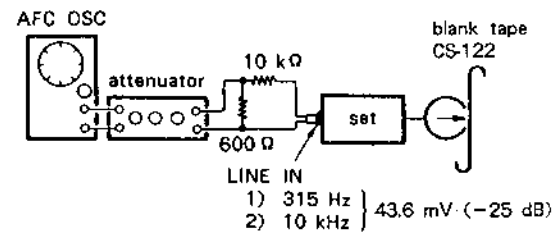

2. Mode: playback

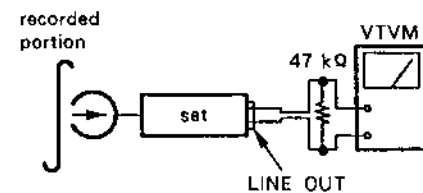

Playback the signal recorded in step 1. Confirm that the 10 kHz playback output is 0 ± 0.5 dB relative to the 315 Hz output. If necessary, adjust RV42 (L-CH), RV62 (R-CH) and repeat the steps given above.

3. After adjustment, release the short on TP1.

Adjustment Location: HX PRO board

Record Level Adjustment **DECK B**

Setting:

- REC LEVEL control: standard record (See page 5.)
- Short test pin TP1 on main board.

Procedure:

1. Mode: record

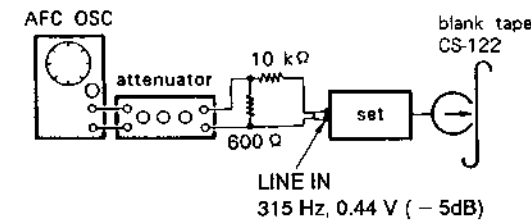

2. Mode: playback

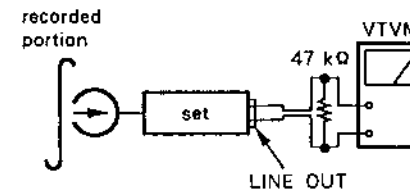

3. Playback the signal recorded in step 1. Confirm that the signal level is within the specification below. If necessary, adjust RV102 (L-CH), RV202 (R-CH) and repeat the step 1 and 2.
4. After adjustment, release the short on TP1.

Specification: LINE OUT level: -5 ± 0.5 dB (0.41 - 0.46 V)

Adjustment Location: main board (Component Side)

- Adjustment Parts Location Diagram -

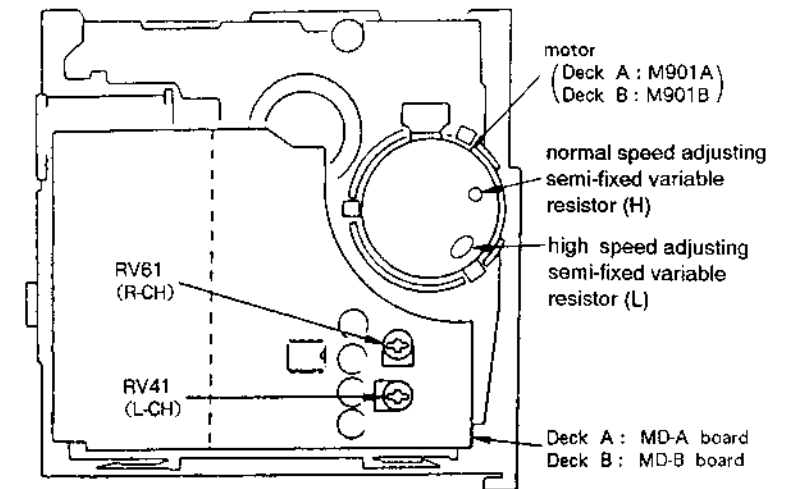

HX PRO board (Component side)

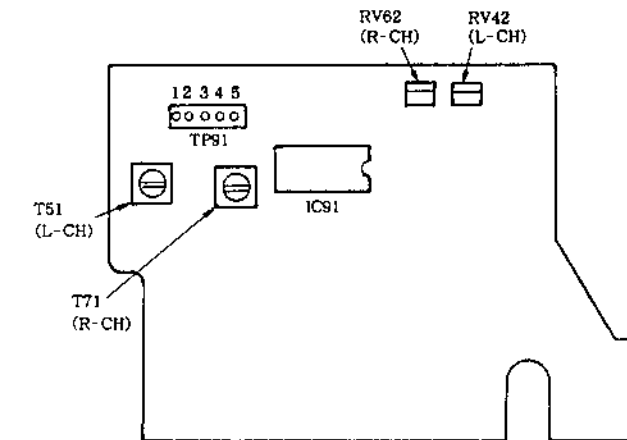

MAIN board (component side)

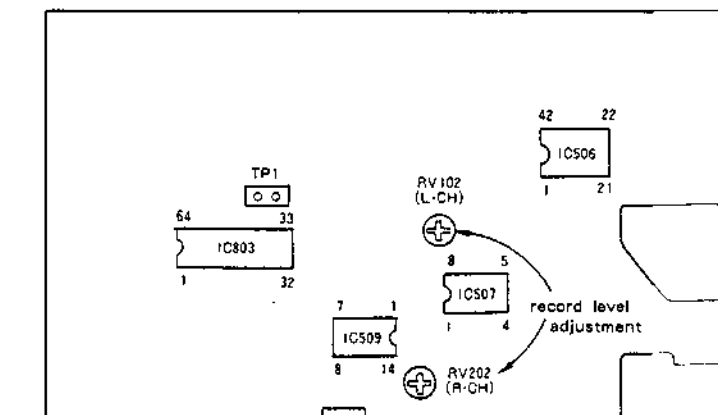

4-1. M50964-

| No. | PIN NAME |
|-----|----------|
| 1 | Vcc |
| 2 | AVss |
| 3 | VREF |
| 4 | D/A |
| 5 | PWM |
| 6 | P63 |
| 7 | P62 |
| 8 | P61 |
| 9 | P60 |
| 10 | AN7 |
| 11 | AN6 |
| 12 | AN5 |
| 13 | AN4 |
| 14 | AN3 |
| 15 | AN2 |
| 16 | P41 |
| 17 | P40 |
| 18 | P37 |
| 19 | P36 |
| 20 | P35 |
| 21 | P34 |
| 22 | P33 |
| 23 | P32/INT2 |
| 24 | P31 |
| 25 | P30 |
| 26 | INT1 |
| 27 | CN Vss |
| 28 | RESET |
| 29 | X IN |
| 30 | X OUT |
| 31 | φ |
| 32 | Vss |
| 33 | P57 |
| 34 | P56 |
| 35 | P55 |
| 36 | P54 |
| 37 | P53 |
| 38 | P52 |
| 39 | P51 |
| 40 | P50 |
| 41 | P17 |
| 42 | P16 |

SECTION 4 DIAGRAMS

-Adjustment Parts Location Diagram-

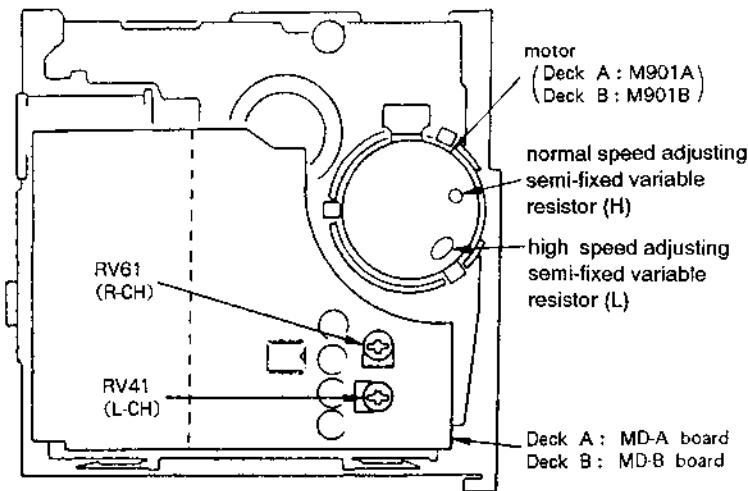

HX PRO board (Component side)

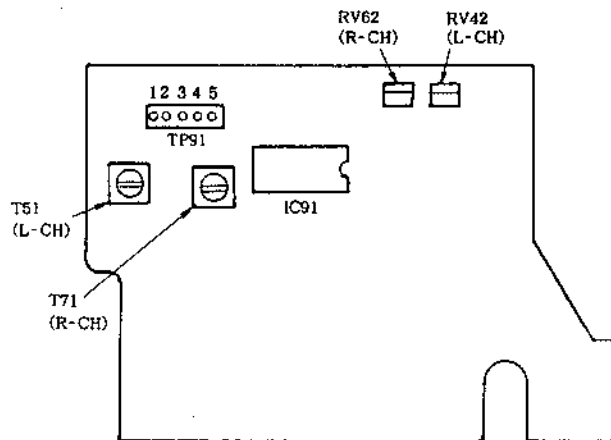

MAIN board (component side)

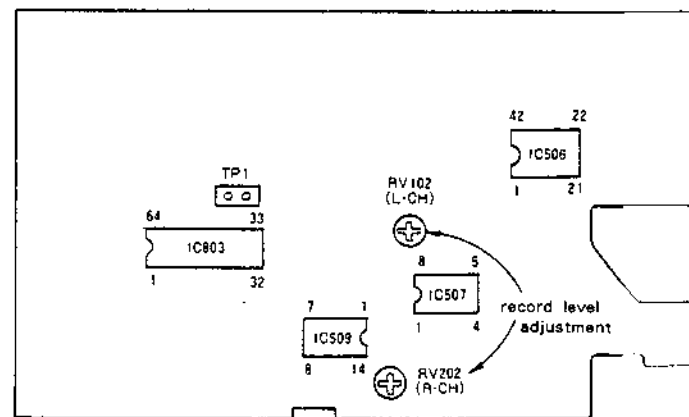

4-1. M50964-210SP (IC803)

| No. | PIN NAME | SIGNAL | I/O | FUNCTION |
|-----|----------|------------|-----|--|
| 1 | Vcc | | | Power supply |
| 2 | AVss | | | Ground |
| 3 | VREF | | | Power supply |
| 4 | D/A | Cμ OUT | O | Data output to counter microcomputer |
| 5 | PWM | | | Not used |
| 6 | P63 | AMS | O | LED output (L:light on) |
| 7 | P62 | A▶ | O | LED output (L:light on) |
| 8 | P61 | A◀ | O | LED output (L:light on) |
| 9 | P60 | A PLAY | O | LED output (L:light on) |
| 10 | AN7 | Cμ IN | I | Data input from counter microcomputer |
| 11 | AN6 | | | Not used |
| 12 | AN5 | B HALF DET | I | Cassette half detection and erase proof tab detection for deck B |
| 13 | AN4 | KEY Z | I | Input from operation switches |
| 14 | AN3 | KEY Y | I | Input from operation switches |
| 15 | AN2 | KEY X | I | Input from operation switches |
| 16 | P41 | B▶ | O | LED output (L:light on) |
| 17 | P40 | B◀ | O | LED output (L:light on) |
| 18 | P37 | B PLAY | O | LED output (L:light on) |
| 19 | P36 | B II | O | LED output (L:light on) |
| 20 | P35 | B●RELAY | O | LED output (L:light on) |
| 21 | P34 | NR B/C | O | Dolby NR B/C select |
| 22 | P33 | NR ON/OFF | O | Dolby NR ON/OFF select |
| 23 | P32/INT2 | AUB IN | I | AUDIO BUS input |
| 24 | P31 | 70/120 | O | 70μS playback equalizer select deck |
| 25 | P30 | AUB OUT | O | AUDIO BUS output |
| 26 | INT1 | AUB IN | I | AUDIO BUS reverse input |
| 27 | CN Vss | | | Ground |
| 28 | RESET | | I | Reset signal input |
| 29 | X IN | | I | 4,00MHz oscillation signal input |
| 30 | X OUT | | O | 4,00MHz oscillation signal output |
| 31 | φ | | | Not used |
| 32 | Vss | | | Ground |
| 33 | P57 | TEST | I | Test mode input |
| 34 | P56 | DIR B | I | Deck B direction switch input |
| 35 | P55 | B 70/120 | I | Deck B 70/120μS switch input |
| 36 | P54 | B SHUT | I | Deck B reel table rotation detect (the mechanism is shut off after one second with no signal change) |
| 37 | P53 | A 70/120 | I | Deck A 70/120μS switch input |
| 38 | P52 | A SHUT | I | Deck A reel table rotation detect (the mechanism is shut off after one second with no signal change) |
| 39 | P51 | A HALF DET | I | Cassette half detection for deck A |
| 40 | P50 | AMS IN | I | AMS signal input |
| 41 | P17 | M MUTE | O | Meter mute output (not used) |
| 42 | P16 | L MUTE | O | Line mute output (L:mute) |

| No. | PIN NAME | SIGNAL | I/O | FUNCTION |
|-----|----------|-----------|-----|---|
| 43 | P15 | PASS | O | Pass amp select output |
| 44 | P14 | REC/PB | O | RBC/PB select output (L:record) |
| 45 | P13 | AMS/BS | O | AMS/BS amp select output |
| 46 | P12 | AMS A/B | O | AMS/BS amp deck A or deck B select (L:deck B) |
| 47 | P11 | SEL A/B | O | AMS/BS amp deck A or deck B select (L:deck B) |
| 48 | P10 | BTAS | O | Deck B record bias select |
| 49 | P07 | REPLAY | O | REC/PB switching relay output |
| 50 | P06 | B PM | O | Output to hold deck B solenoid |
| 51 | P05 | B KICK | O | Output to kick deck B solenoid |
| 52 | P04 | A PM | O | Output to hold deck A solenoid |
| 53 | P03 | A KICK | O | Output to kick deck A solenoid |
| 54 | P02 | BM H/L | O | Deck B capstan motor high speed/normal speed select (H: high speed dubbing or FF/REW) |
| 55 | P01 | AM H/L | O | Deck A capstan motor high speed/normal speed select (H: high speed dubbing or FF/REW) |
| 56 | P00 | M ON/OFF | O | Capstan motor ON/OFF output (H:STOP) |
| 57 | P27 | B R MUTE | O | Deck B record mute signal output (H:mute) |
| 58 | P26 | 35μSEC | O | Deck A is set to L at 70μsec during high speed dubbing. |
| 59 | P25 | AP LED | O | LED output (L:light on) |
| 60 | P24 | DUB H | O | LED output (L:light on) |
| 61 | P23 | DUB N | O | LED output (L:light on) |
| 62 | P22 | CD DUB | O | LED output (L:light on) |
| 63 | P21 | A II | O | LED output (L:light on) |
| 64 | P20 | J600/J700 | I | Terminal of version setting (this set is H) |

• Test Mode

When making pin ③ of IC803 low (connect TP1 to ground with jumper wire), following function operates.

- Source monitor
Release the line mute while recording.
- High speed playback
On playing back, while pressing HIGH SPEED (DUBBING) button, high speed playback operates.
- Record memory stop
Using DIRECTION MODE switch \rightleftarrows , returns to the recording start point and stops or plays.
- LED indication of slide switch
When making Deck B pause, LED indicates the positions of DIRECTION MODE switch and (AUTO CD SYNCRO) MODE switch.

| Switch | Position | LED |
|----------------|--------------------|-------------------------------------|
| DIRECTION MODE | \rightleftarrows | Deck A ◀ Deck A PLAY Deck A ▶ |
| | RELAY | |
| MODE | NORM | Deck B ◀ |
| | FADE | Deck B PLAY |
| | ERASE | Deck B ▶ |

- AGC gain check
When setting DIRECTION MODE switch to \rightleftarrows and recording, AGC gain becomes maximum.

• Circuit Boards Location

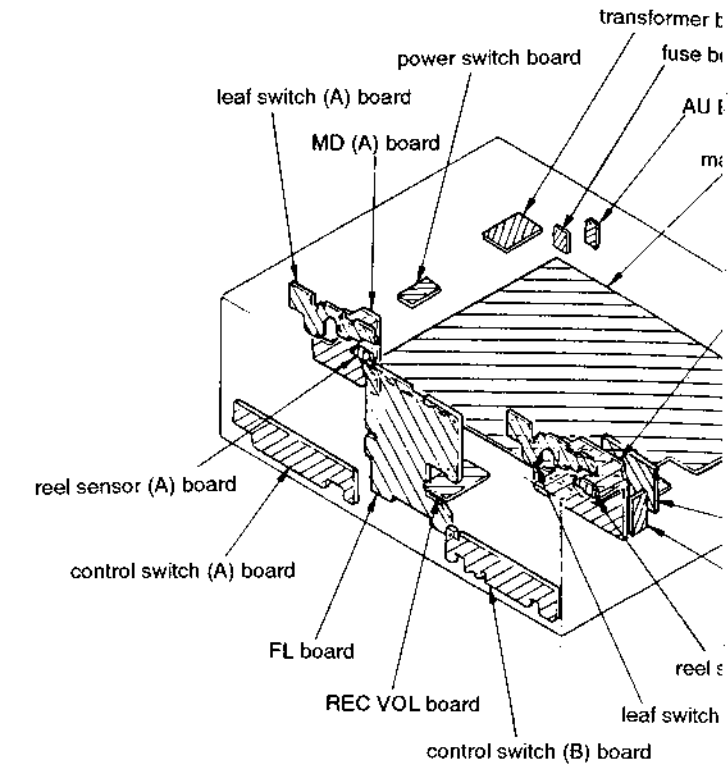

• Semiconductor Lead Layouts

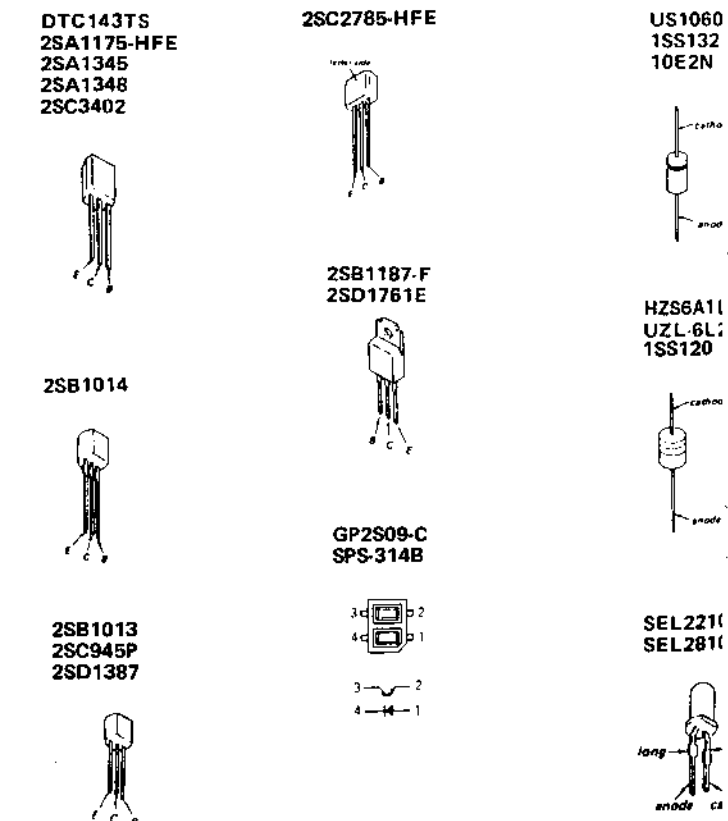

| I/O | FUNCTION |
|-----|--|
| ○ | Pass amp select output |
| ○ | REC/PB select output (L:record) |
| ○ | AMS/BS amp select output |
| ○ | AMS/BS amp deck A or deck B select (L:deck B) |
| ○ | AMS/BS amp deck A or deck B select (L:deck B) |
| ○ | Deck B record bias select |
| ○ | REC/PB switching relay output |
| ○ | Output to hold deck B solenoid |
| ○ | Output to kick deck B solenoid |
| ○ | Output to hold deck A solenoid |
| ○ | Output to kick deck A solenoid |
| ○ | Deck B capstan motor high speed/normal speed select(H: high speed dubbing or FF/REW) |
| ○ | Deck A capstan motor high speed/normal speed select(H: high speed dubbing or FF/REW) |
| ○ | Capstan motor ON/OFF output (H:STOP) |
| ○ | Deck B record mute signal output (H:mute) |
| ○ | Deck A is set to L at 70μsec during high speed dubbing. |
| ○ | LED output (L:light on) |
| ○ | LED output (L:light on) |
| ○ | LED output (L:light on) |
| ○ | LED output (L:light on) |
| ○ | LED output (L:light on) |
| I | Terminal of version setting (this set is H) |

● Circuit Boards Location

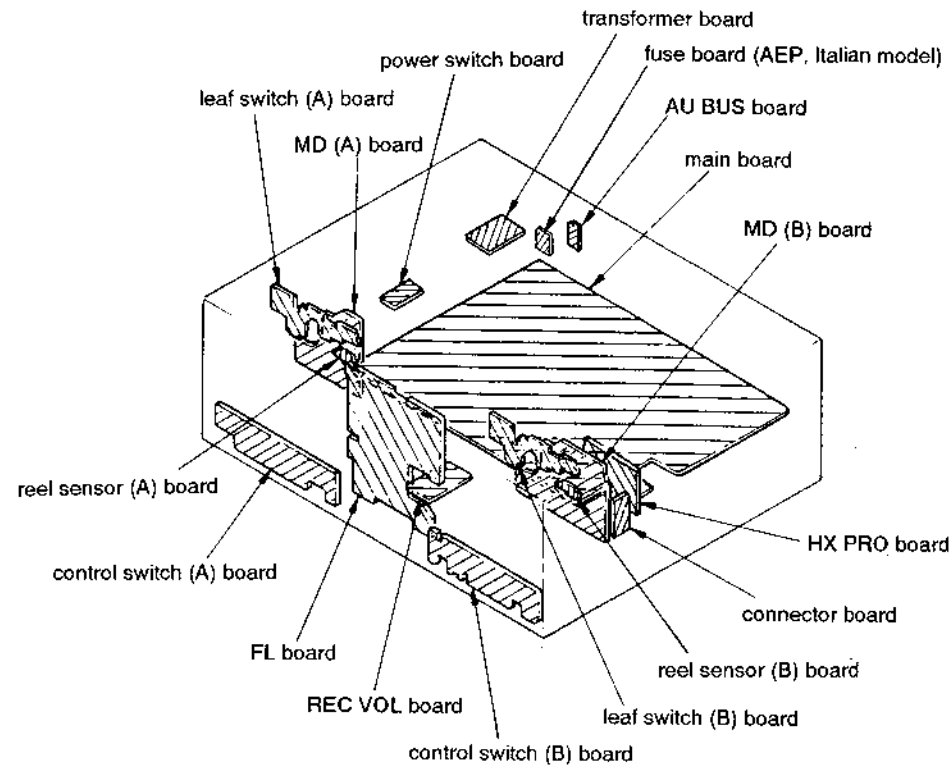

Note on Schematic Diagram:

- All capacitors are in μF unless otherwise noted. pF: μuF
- All resistors are in Ω and ¼ W or less unless otherwise specified.
- Components for right channel have same values as for left channel. Reference numbers are coded from
- \triangle : internal component.
- $\text{---}\text{---}\text{---}$: fusible resistor.

Note: The components identified by mark \triangle or dotted line with mark \triangle are critical for safety. Replace only with part number specified.

- $\text{B}+$: B + Line.
- $\text{B}-$: B - Line.
- --- : adjustment for repair.
- Voltages and waveforms are dc with respect to ground under no-signal conditions.
- no mark : STOP
- () : Normal speed dubbing
- (()) : High speed dubbing
- \blacktriangleright : FWD \blacktriangleleft : REV \blacksquare : STOP
- $\blacktriangleright\blacktriangleright$: FF $\blacktriangleleft\blacktriangleleft$: REW \bullet : REC
- Voltages are taken with a VOM (input impedance 10 MΩ). Voltage variations may be noted due to normal production tolerances.
- Signal path.
- --- : PB (DECK A)
- --- : PB (DECK B)
- --- : REC (DECK B)

● Semiconductor Lead Layouts

DTC143TS
2SA1175-HFE
2SA1345
2SA1348
2SC3402



2SC2785-HFE



US1060M
1SS132
10E2N

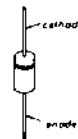

SEL2410G-D



2SB1187-F
2SD1761E



HZS6A1L
UZL-6L2
1SS120



SEL4425G-C
SEL4226R-C
SEL4825D-C
SEL4826D-C



2SB1014



GP2S09-C
SPS-314B



SEL2210R
SEL2810D-C

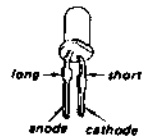

2SB1013
2SC945P
2SD1387



B low (connect TP1 to ground with jumper wires).

Recording.

Pressing HIGH SPEED (DUBBING) button, test.

MODE switch \rightleftarrows , returns to the recording start

switch pause, LED indicates the positions of switch and (AUTO CD SYNCRO) MODE

| Position | LED |
|-----------------------|------------------------------|
| \rightleftarrows | Deck A \blacktriangleleft |
| \rightleftarrows | Deck A PLAY |
| \blacktriangleright | Deck A \blacktriangleright |
| NORM | Deck B \blacktriangleleft |
| FADE | Deck B PLAY |
| ERASE | Deck B \blacktriangleleft |

MODE switch to \rightleftarrows and recording, AGC

• Semiconductor Location

| Ref. No. | Location | Ref. No. | Location |
|----------|----------|----------|----------|
| D11-A | D-33 | Q101 | B-8 |
| D11-B | I-33 | Q102 | B-9 |
| D81-B | I-28 | Q103 | B-9 |
| D101 | F-9 | Q104 | B-9 |
| D201 | E-9 | Q105 | B-9 |
| D503 | C-18 | Q108 | C-12 |
| D504 | C-18 | Q109 | F-12 |
| D505 | C-18 | Q110 | H-11 |
| D506 | C-18 | Q111 | H-9 |
| D507 | D-16 | Q112 | H-9 |
| D508 | D-16 | Q113 | H-9 |
| D509 | C-16 | Q114 | H-10 |
| D510 | D-17 | Q115 | H-11 |
| D511 | D-18 | Q117 | H-10 |
| D512 | D-18 | Q118 | H-10 |
| D513 | D-18 | Q119 | F-12 |
| D514 | D-17 | Q201 | C-8 |
| D515 | D-16 | Q202 | C-9 |
| D516 | D-16 | Q203 | C-9 |
| D517 | D-14 | Q204 | C-9 |
| D519 | D-18 | Q205 | C-9 |
| D520 | H-13 | Q208 | C-12 |
| D521 | H-13 | Q209 | F-12 |
| D522 | H-13 | Q210 | I-12 |
| D523 | C-14 | Q211 | H-8 |
| D524 | C-15 | Q212 | I-9 |
| D525 | D-18 | Q213 | I-9 |
| D801 | D-4 | Q214 | I-10 |
| D802 | B-4 | Q215 | I-11 |
| D803 | C-2 | Q217 | I-10 |
| D804 | C-3 | Q218 | I-10 |
| D805 | C-2 | Q219 | F-12 |
| D806 | C-4 | Q501 | H-13 |
| D807 | H-5 | Q502 | H-13 |
| D808 | I-4 | Q503 | H-13 |
| D809 | I-3 | Q504 | G-13 |
| D810 | I-3 | Q505 | D-14 |
| D811 | K-4 | Q506 | E-14 |
| D812 | K-3 | Q507 | C-14 |
| D813 | K-3 | Q508 | 8-14 |
| D814 | J-4 | Q509 | B-15 |
| D815 | K-5 | Q510 | B-16 |
| D816 | D-3 | Q511 | D-17 |
| D817 | H-14 | Q512 | E-18 |
| D818 | E-15 | Q513 | C-11 |
| D819 | E-16 | Q514 | C-11 |
| D820 | E-16 | Q515 | F-16 |
| D822 | D-4 | Q516 | H-11 |
| D823 | D-4 | Q517 | G-12 |
| D824 | G-16 | Q518 | G-12 |
| D825 | I-17 | Q801 | D-5 |
| D826 | H-18 | Q802 | D-5 |
| D827 | G-17 | Q803 | E-5 |
| D828 | G-17 | Q804 | E-5 |
| | | Q805 | E-5 |
| | | Q806 | D-2 |
| IC21 | J-20 | Q807 | E-2 |
| IC81-A | D-26 | Q808 | E-2 |
| IC81-B | I-26 | Q809 | E-5 |
| IC91 | I-21 | Q810 | H-14 |
| IC501 | C-10 | Q811 | H-15 |
| IC502 | C-13 | Q812 | I-14 |
| IC503 | C-12 | Q813 | F-14 |
| IC504 | E-9 | Q814 | H-15 |
| IC505 | E-13 | Q815 | H-15 |
| IC506 | F-11 | Q816 | H-15 |
| IC507 | H-12 | Q817 | H-16 |
| IC509 | I-13 | Q818 | H-16 |
| IC510 | C-16 | Q819 | H-16 |
| IC511 | D-14 | Q820 | H-16 |
| IC801 | E-3 | Q822 | F-15 |
| IC802 | H-18 | Q823 | F-15 |
| IC803 | G-15 | Q824 | F-16 |
| | | Q825 | F-18 |
| Q11-A | B-26 | Q826 | F-17 |
| Q11-B | G-26 | Q827 | F-17 |
| Q12-A | D-31 | Q828 | F-16 |
| Q12-B | I-31 | Q829 | F-17 |
| Q14-A | B-30 | Q830 | F-17 |
| Q14-B | G-31 | Q831 | G-18 |
| Q21 | J-20 | Q832 | G-18 |
| Q81-B | G-27 | Q833 | G-14 |
| Q82-B | H-27 | | |
| Q83-B | H-27 | | |

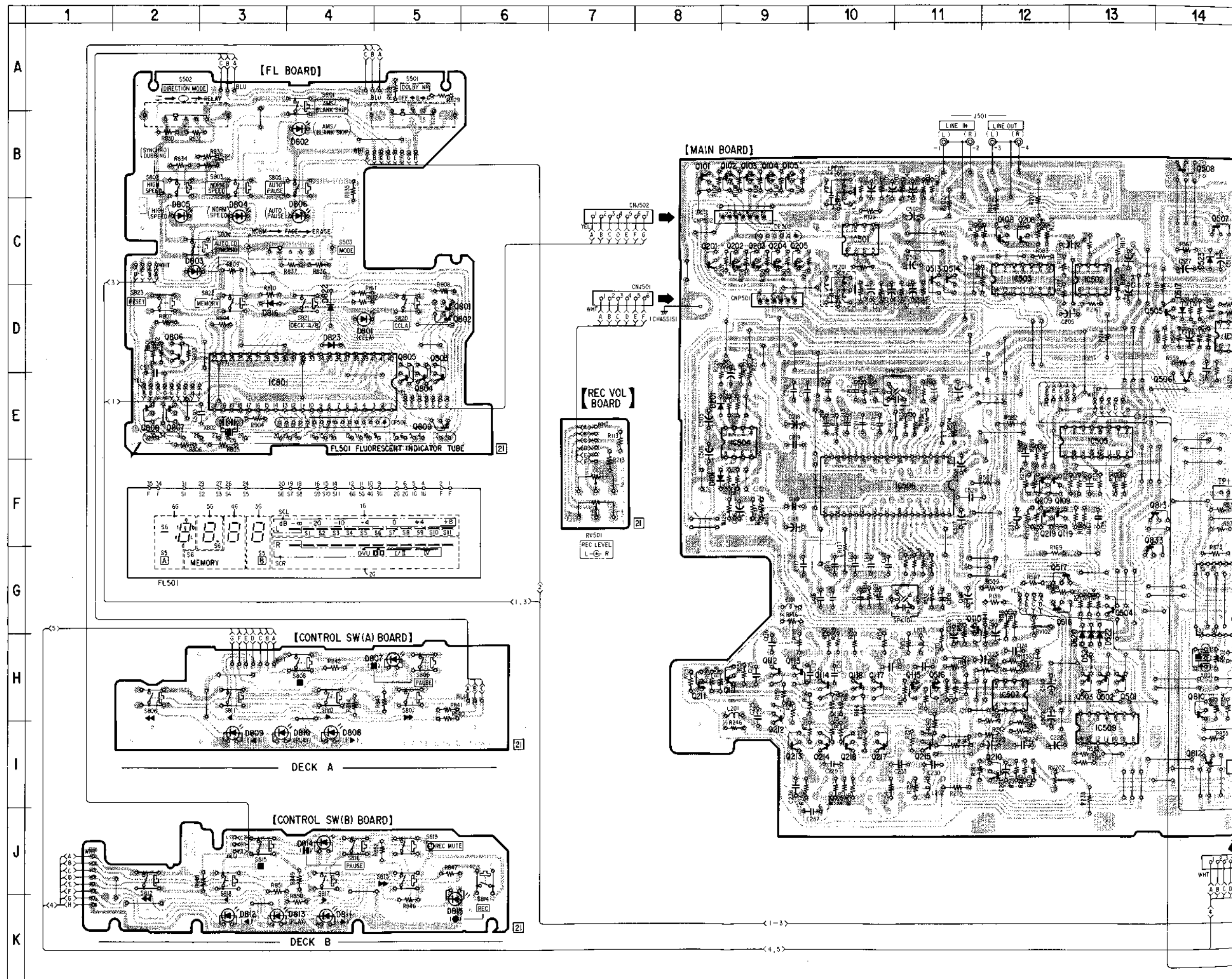

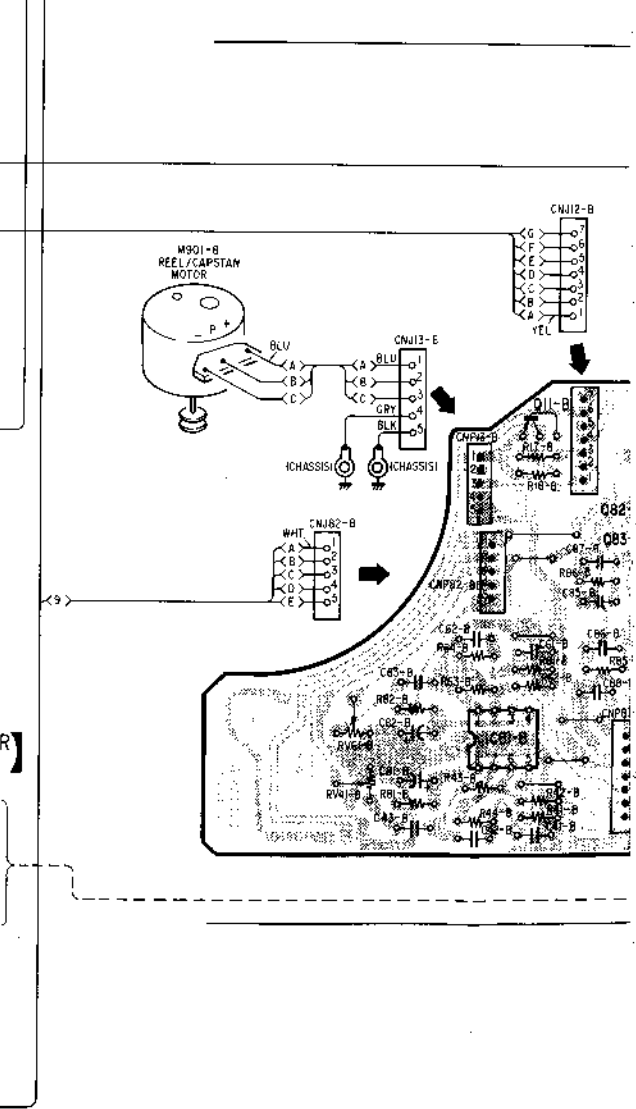
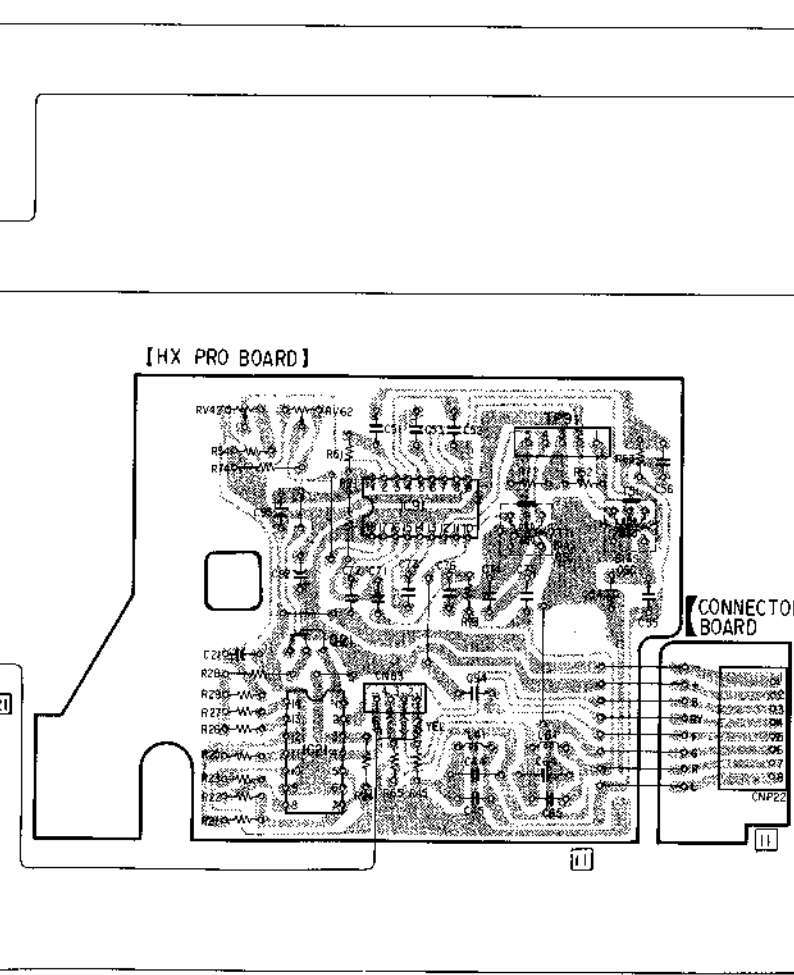
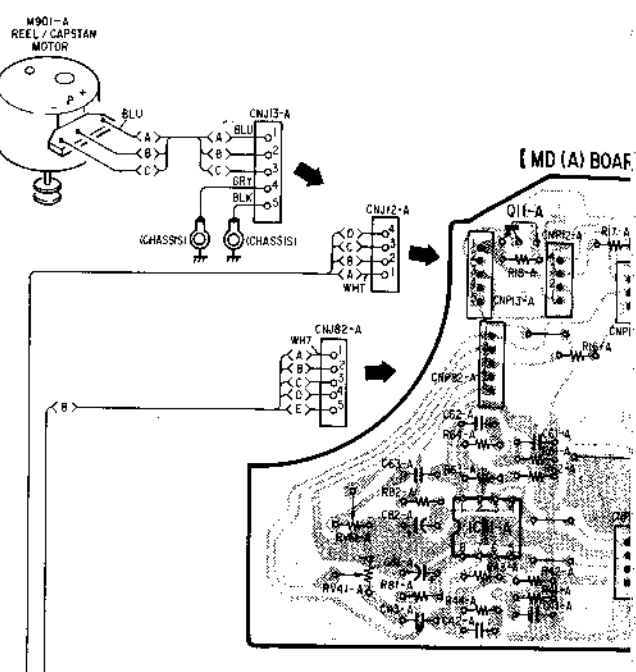
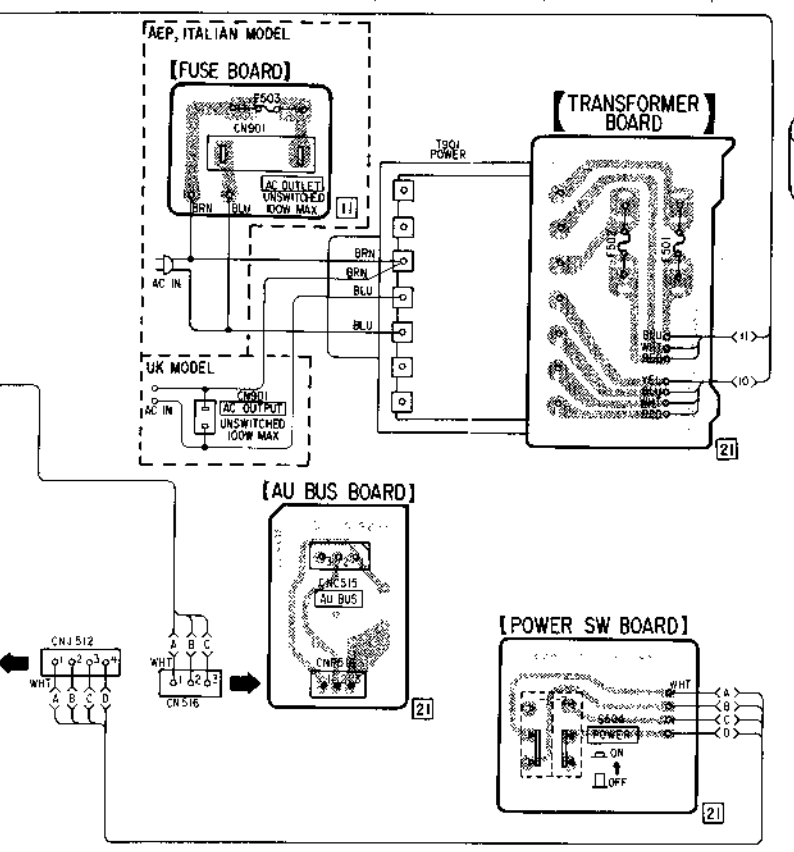
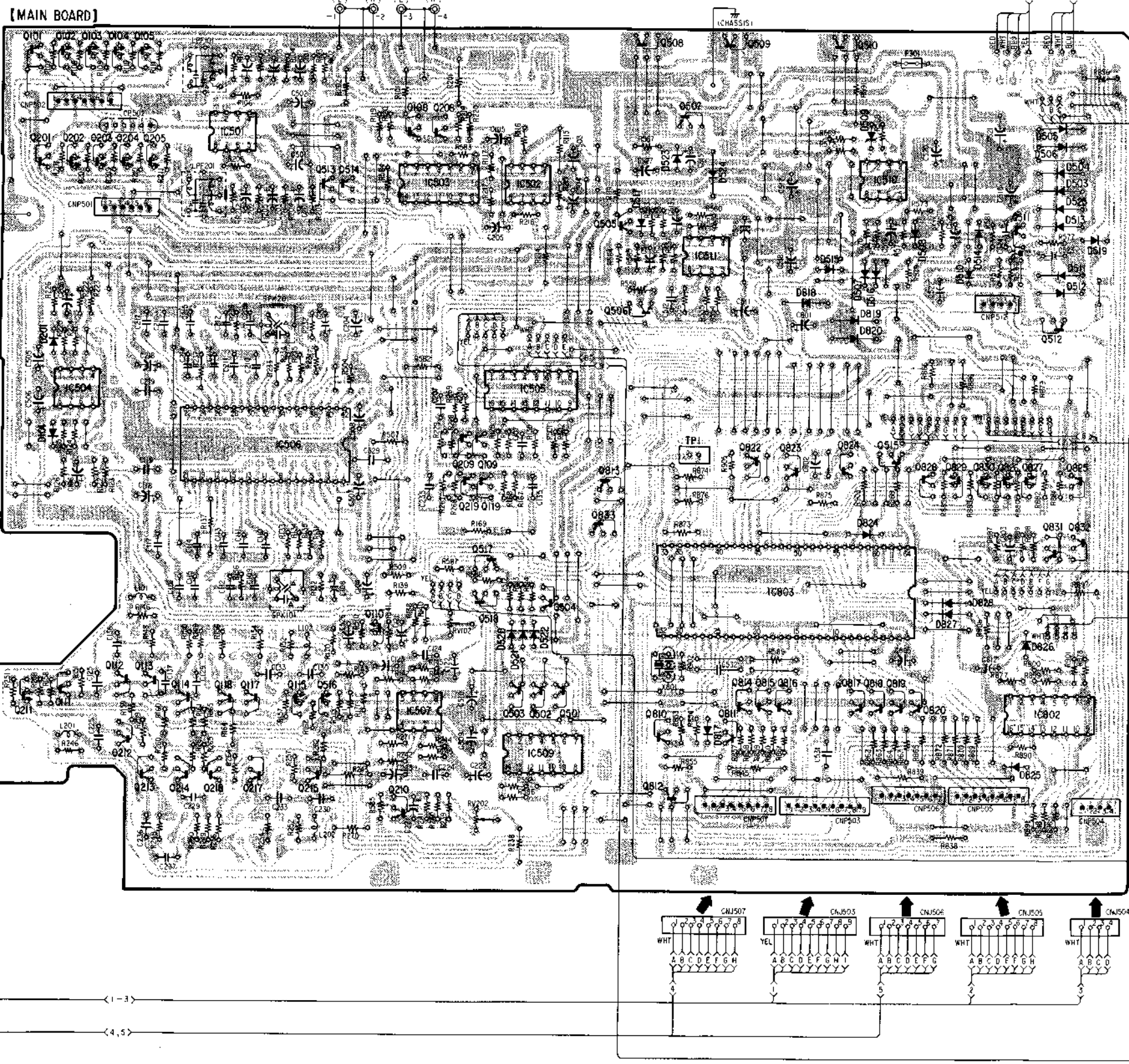

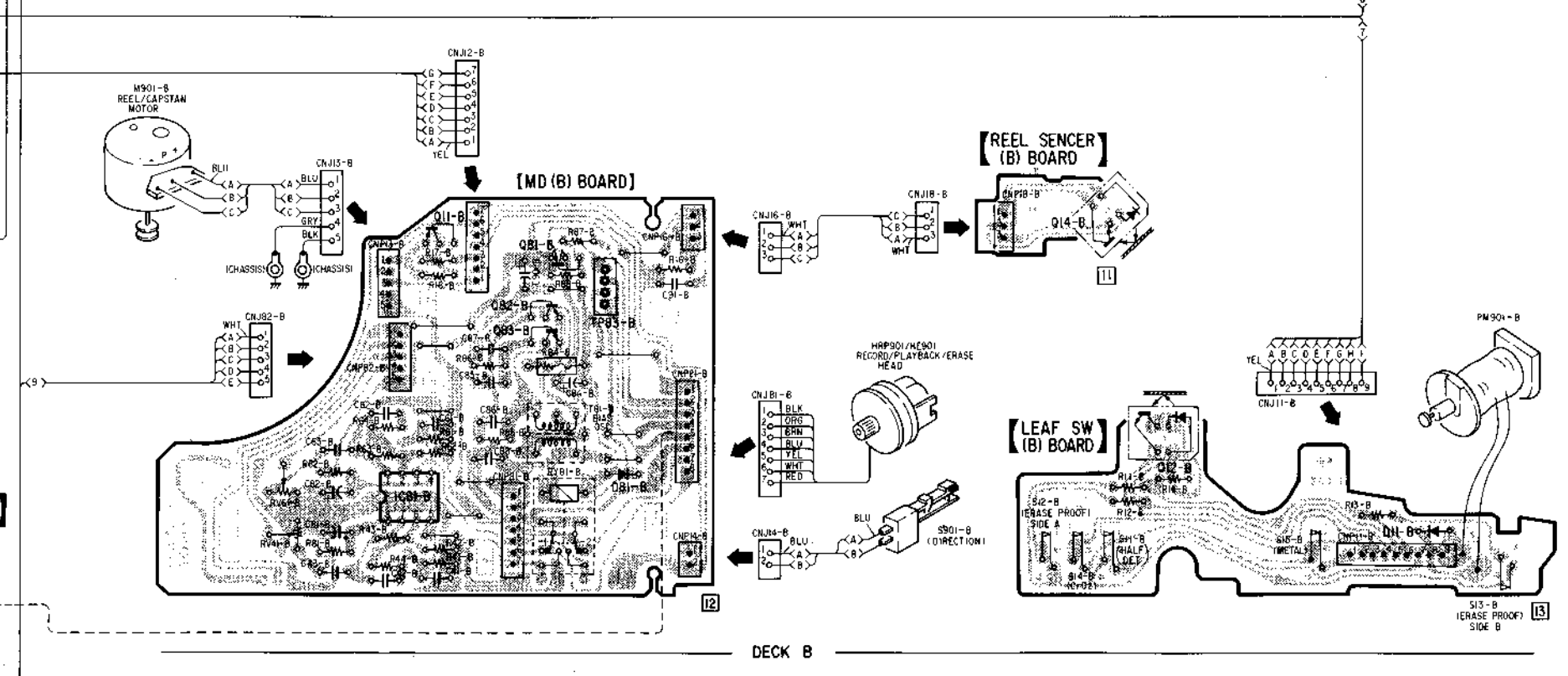
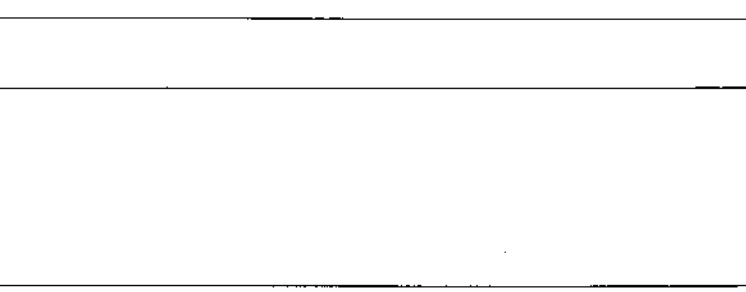
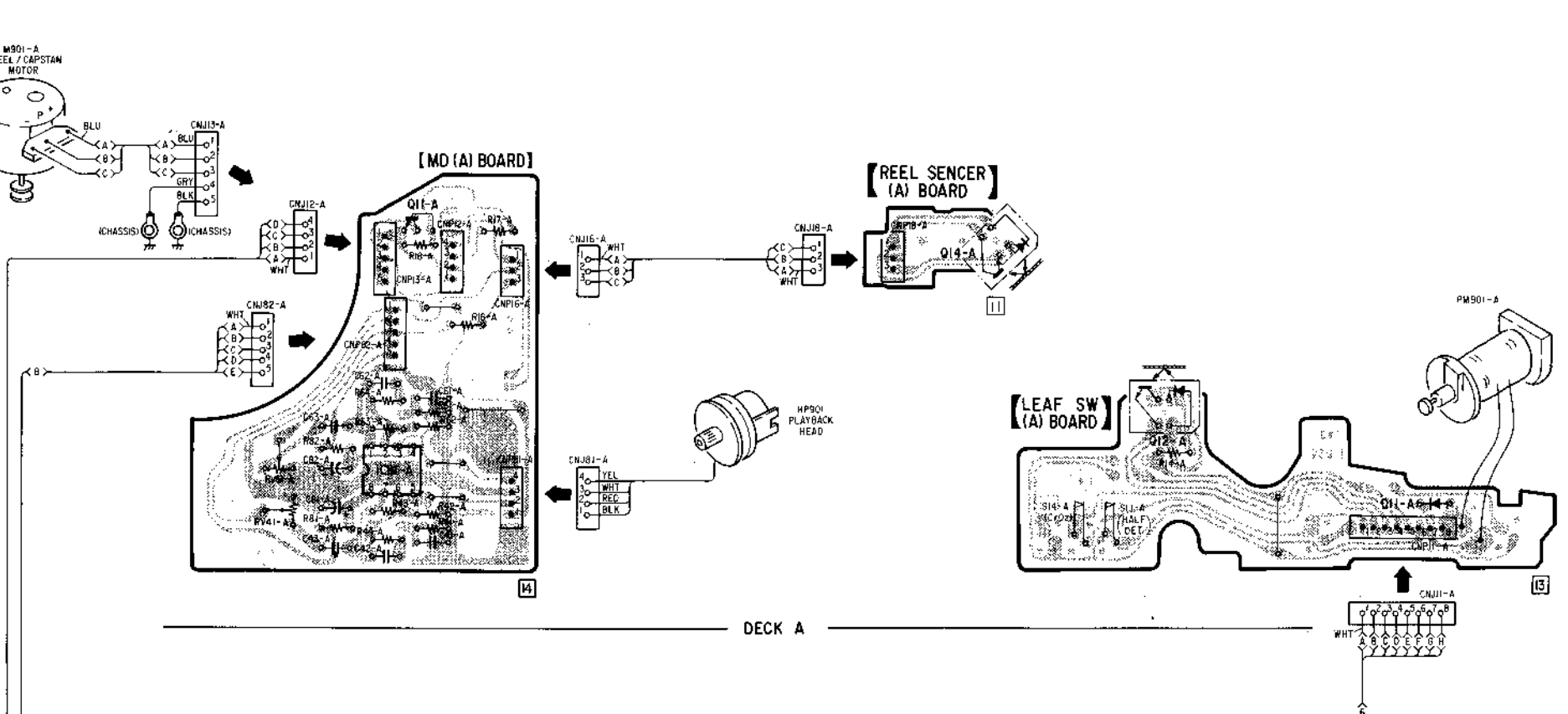
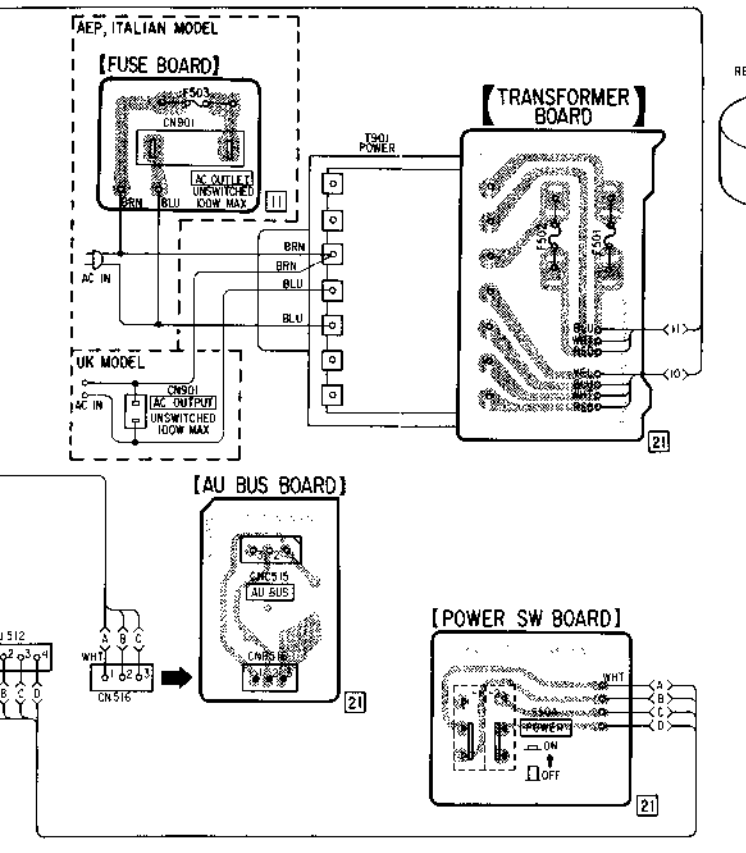

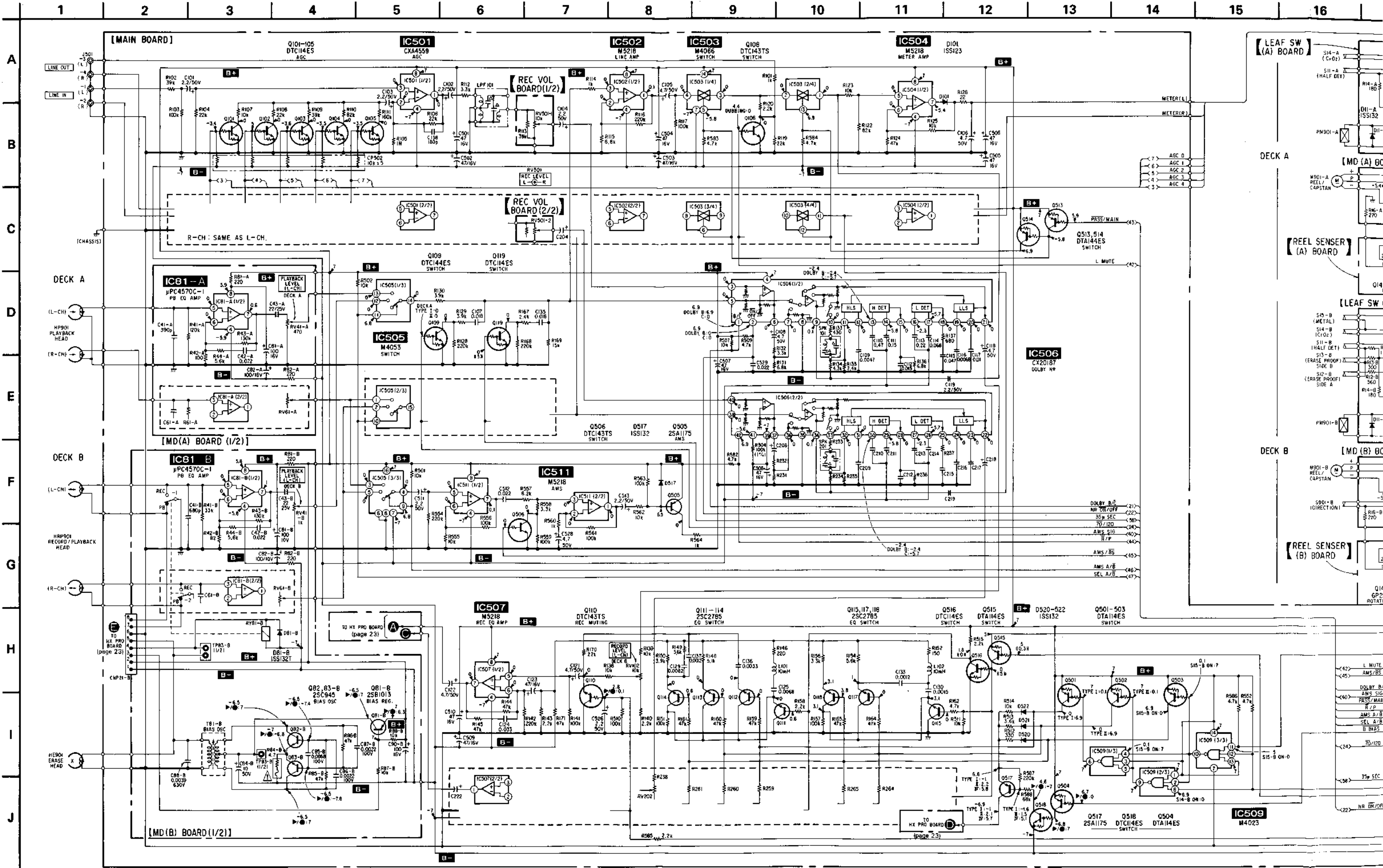

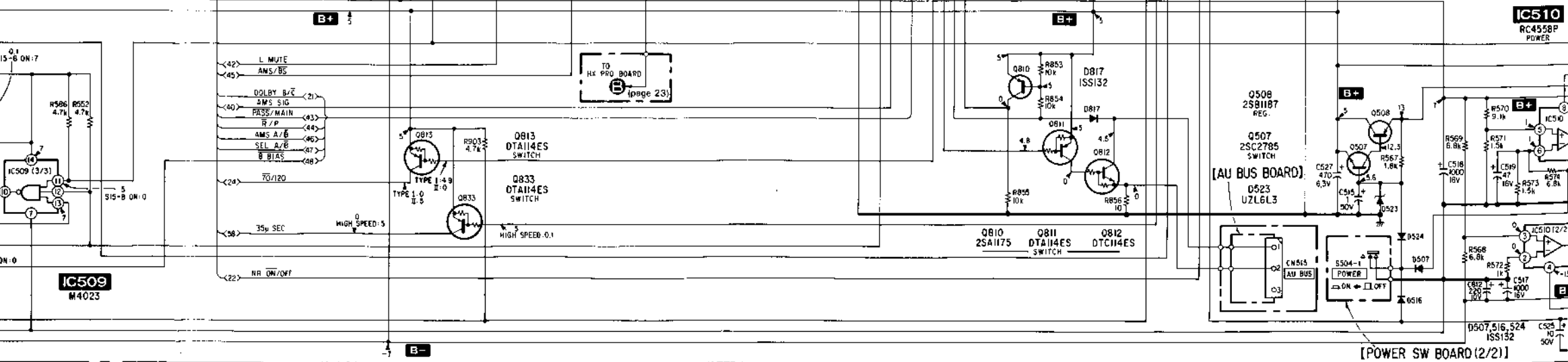
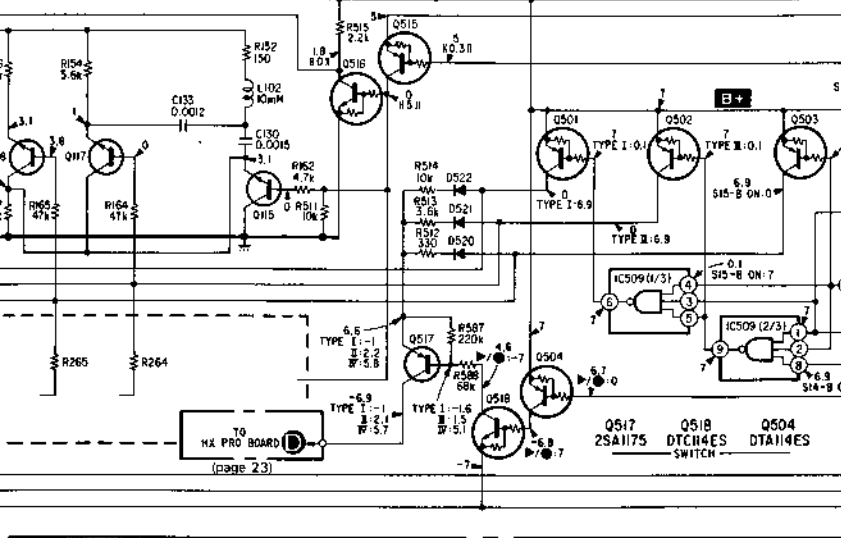
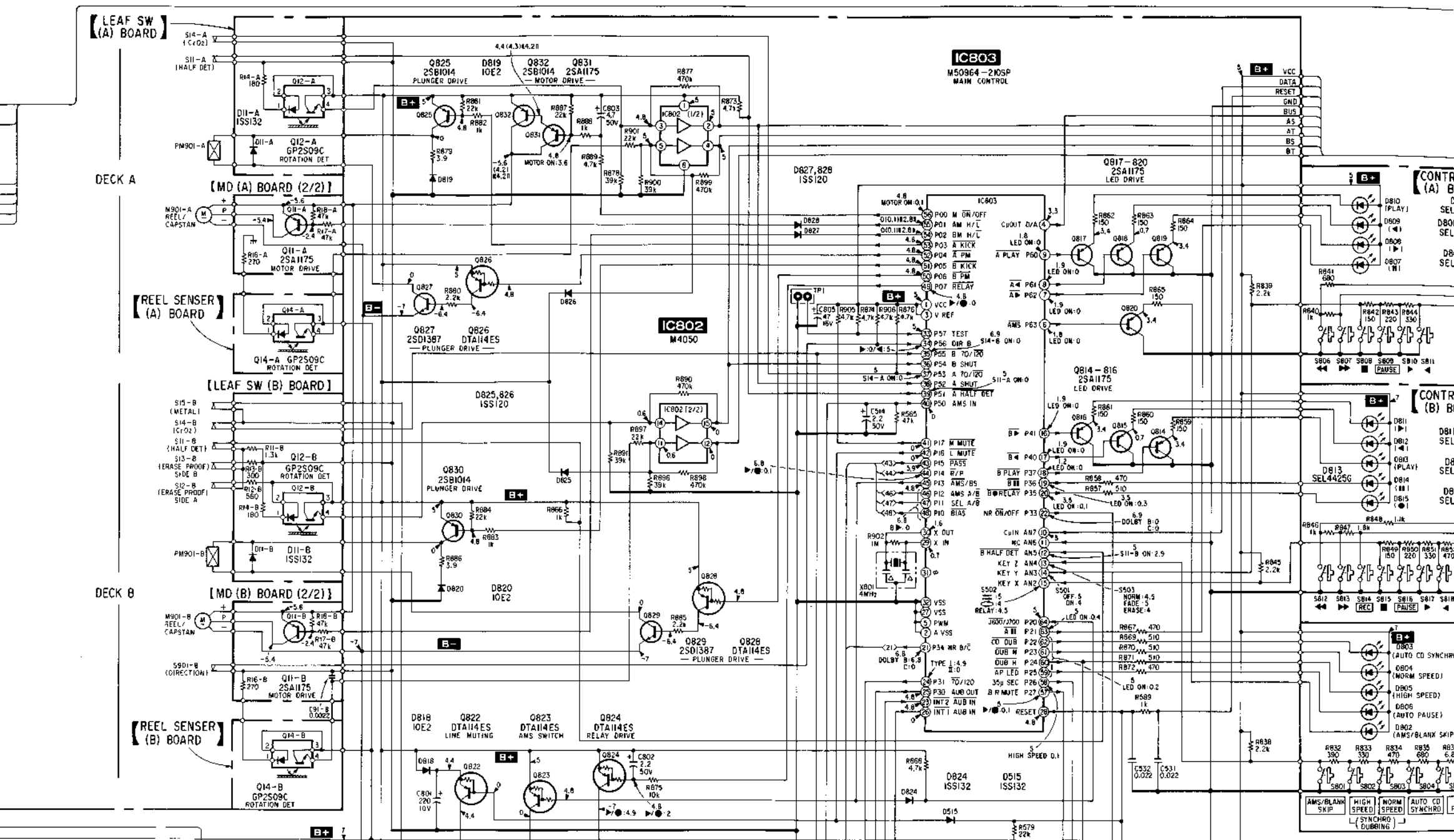
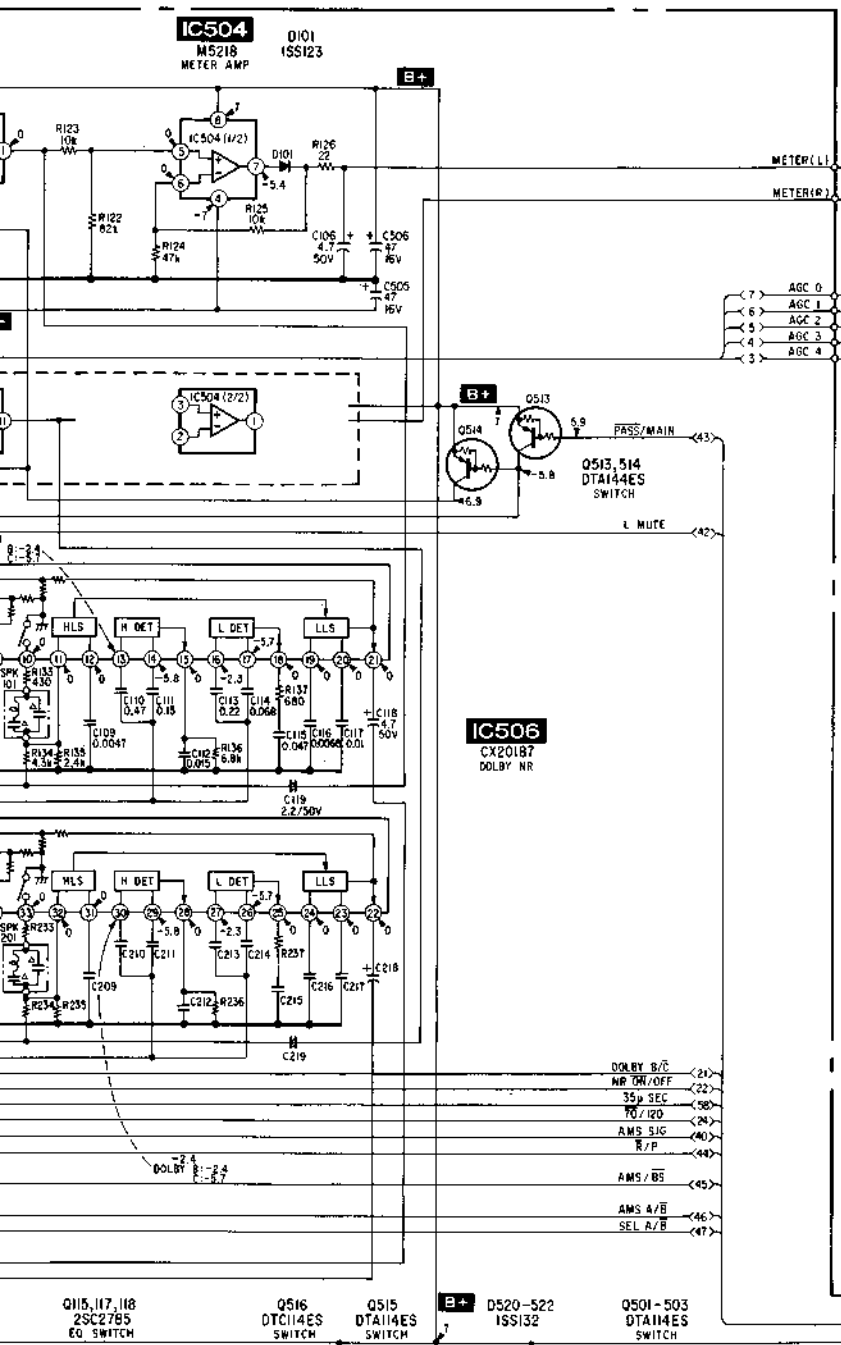

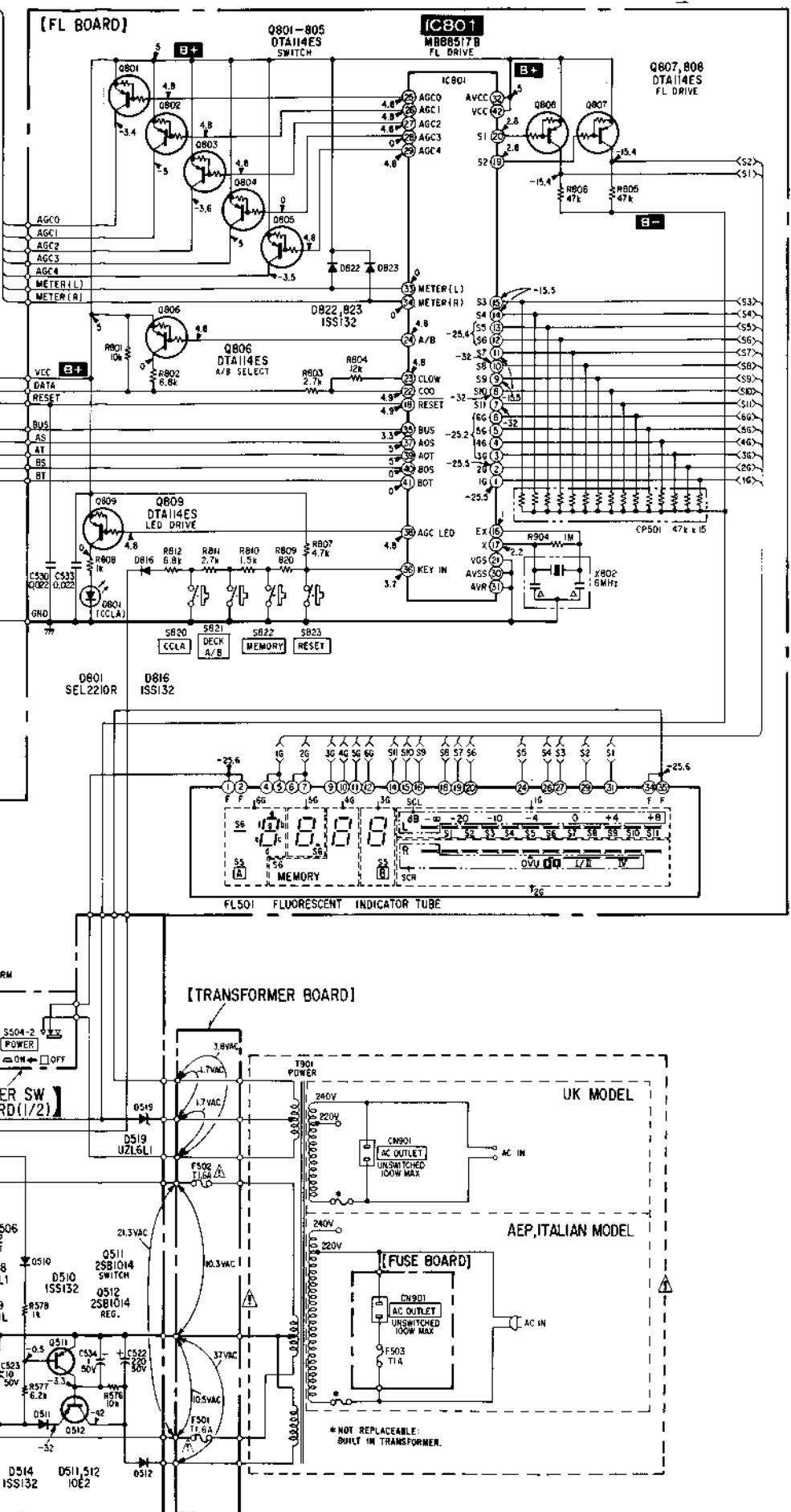
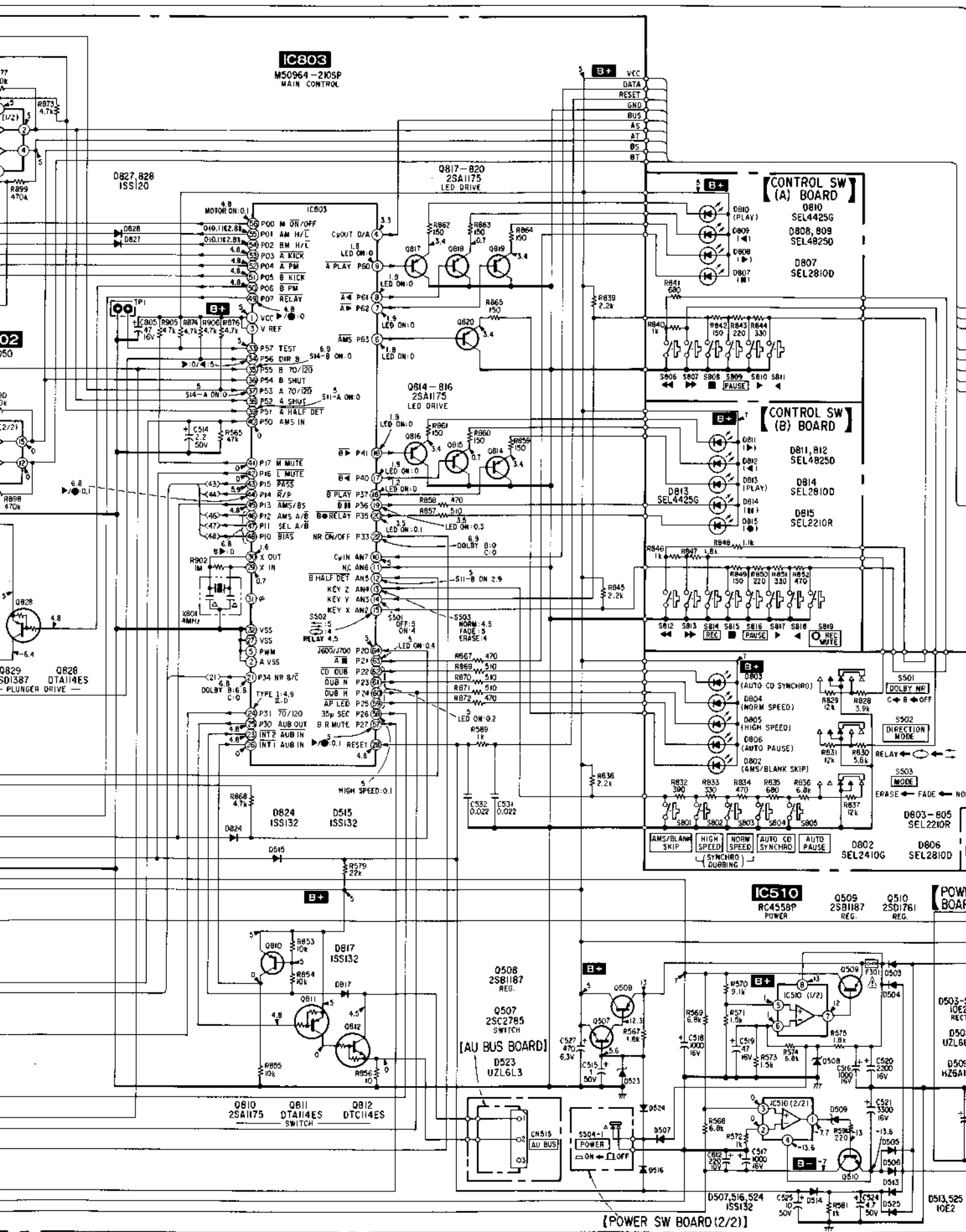

A
B
C
D
E
F
G
H
I
J

SECTION 5
EXPLODED VIEWS

4-4. SCHEMATIC DIAGRAM (HX PRO BOARD) - See page 11 for notes.

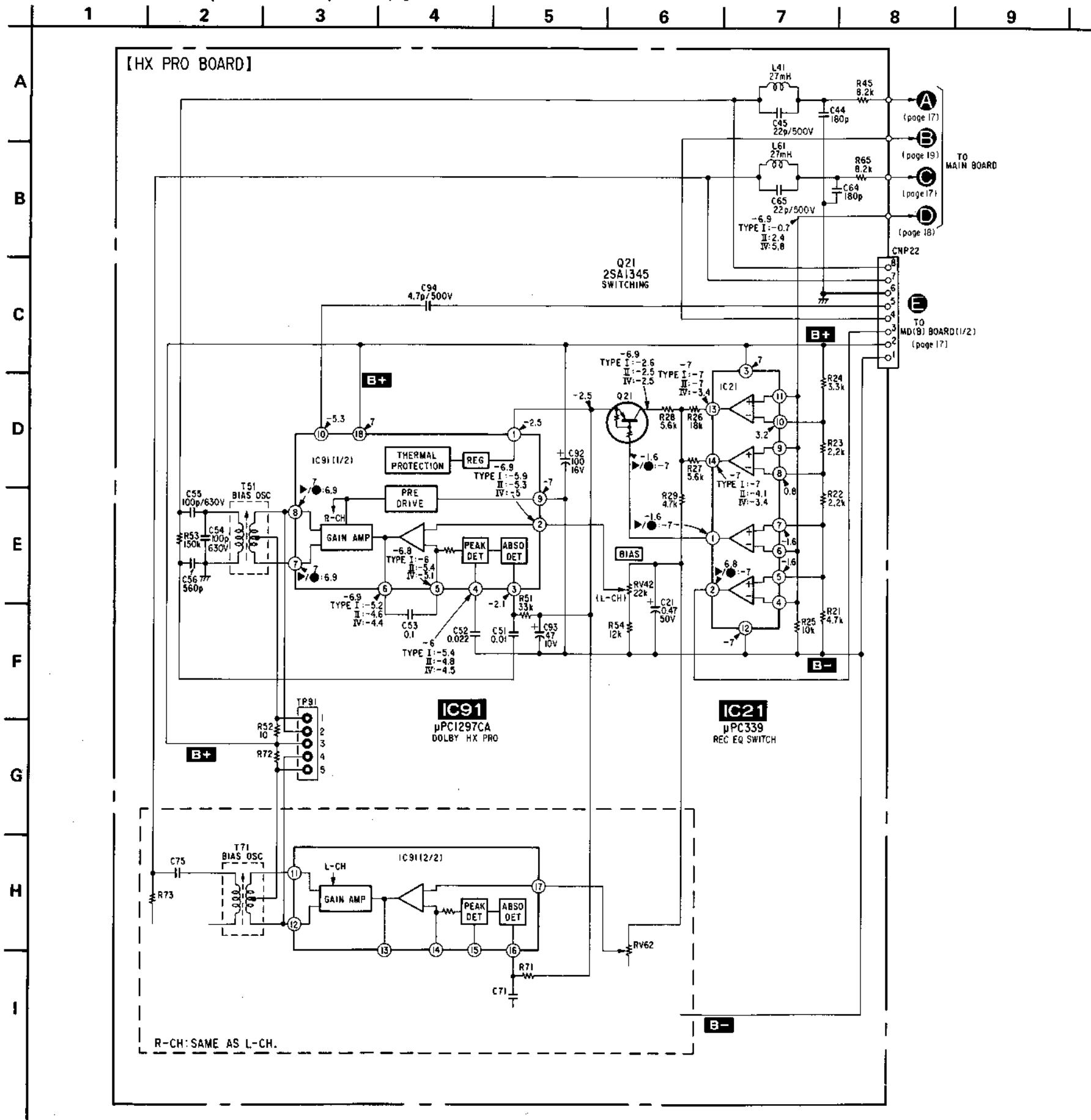

NOTE:

- The mechanical parts with no reference number in the exploded views are not supplied.
- The construction parts of an assembled part are indicated with a collation number in the remark column.
- Items marked "*" are not stocked since they are seldom required for routine service. Some delay should be anticipated when ordering these items.
- Due to standardization, parts with part number suffix -XX and -X may be different from the parts specified in the components used on the set.
- Color Indication of Appearance Parts Example:
(RED) ... KNOB, BALANCE (WHITE)
↑ Cabinet's Color ↑ Parts Color

5-1. CHASSIS SECTION

- A : TRANSFORMER board
- B : POWER SW board
- C : AU BUS board

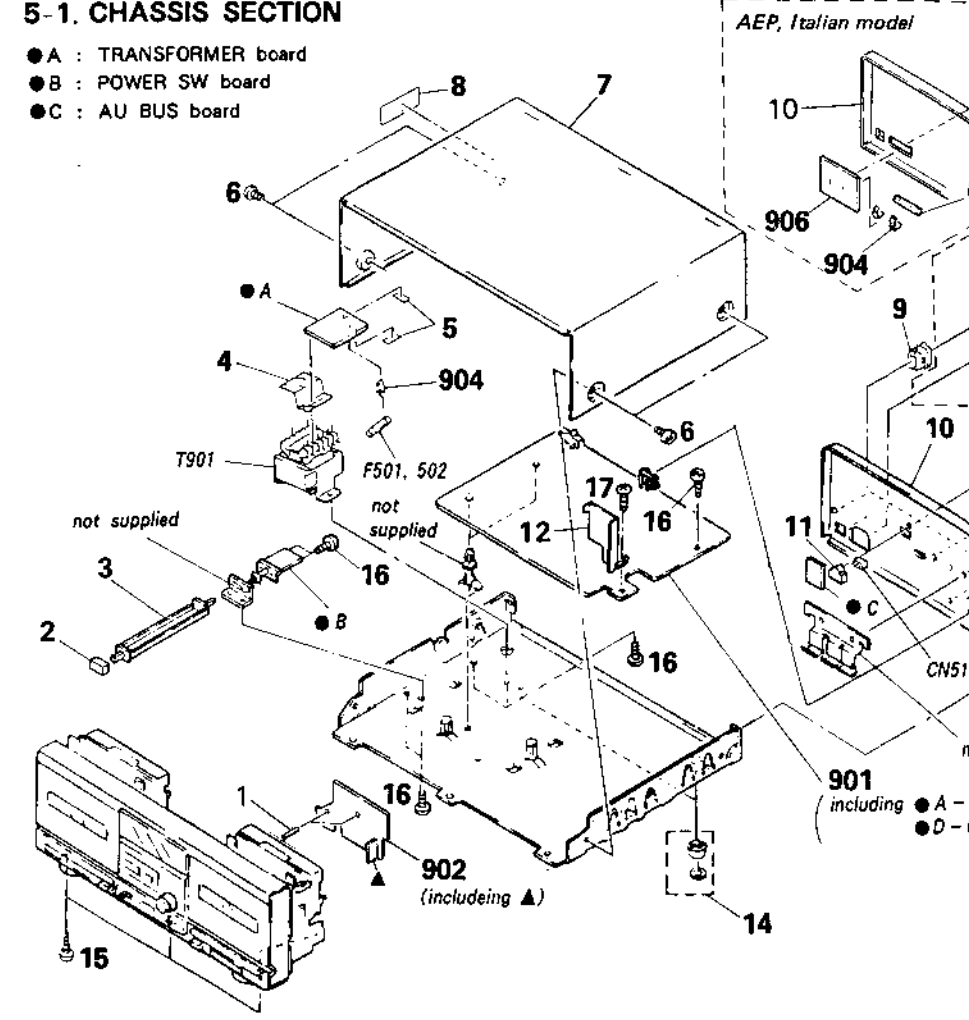

| Ref.No | Part No. | Description | Remark | Ref.No | Part No. | Description | Remark |
|--------|---------------|--------------------------------|--------|--------|---------------|---------------------|--------|
| 1 | *3-682-419-21 | HOLDER, P.C.B | | 17 | 7-685-646-79 | SCREW +BVTT 3X6 (S) | |
| 2 | 4-922-903-01 | BUTTON (POWER) | | 18 | 7-685-533-11 | SCREW +BVTT 3X6 (S) | |
| 3 | *3-350-114-01 | LEVER (POWER SW) | | 19 | 7-621-849-00 | SCREW +BVTT 3X6 (S) | |
| 4 | *3-337-136-01 | COVER, TRANSFORMER SAFETY | | 901 | *A-2006-125-A | MO | |
| 5 | *3-701-947-13 | LABEL (T1.6A), FUSE | | 902 | 1-630-423-11 | PC | |
| 6 | 3-704-366-01 | SCREW (CASE) (M3X8) | | 904 | 1-533-162-00 | HO | |
| 7 | 4-919-379-11 | CASE | | 905 | 1-555-750-00 | AI | |
| 8 | 3-703-079-21 | (UK) ... LABEL, CAUTION (BACK) | | | 1-556-562-00 | UI | |
| 9 | *3-703-244-00 | BUSHING (2104), CORD | | 906 | *1-626-652-11 | AE | |
| 10 | *3-350-131-41 | (AEP, Italian) ... PANEL, BACK | | CN515 | *1-565-562-11 | CO | |
| | | | | CN901 | 1-526-751-00 | UI | |
| 11 | 3-332-819-01 | HOLDER CONNECTOR | | | 1-526-794-11 | AI | |
| 12 | *3-350-123-01 | PLATE (MDB), SHIELD | | F501 | 1-532-259-00 | FU | |
| 13 | *3-337-402-01 | BAND, BINDING | | F502 | 1-532-259-00 | FU | |
| 14 | X-4917-254-1 | FOOT ASSY | | F503 | 1-532-078-00 | AF | |
| 15 | 7-682-547-09 | SCREW +BVTT 3X6 (S) | | T901 | 1-449-460-11 | TR | |
| 16 | 7-682-547-04 | SCREW +BVTT 3X6 (S) | | | | | |

SECTION 5 EXPLODED VIEWS

NOTE:

- The mechanical parts with no reference number in the exploded views are not supplied.
- The construction parts of an assembled part are indicated with a collation number in the remark column.
- Items marked "*" are not stocked since they are seldom required for routine service. Some delay should be anticipated when ordering these items.

- Due to standardization, parts with part number suffix -XX and -X may be different from the parts specified in the components used on the set.
- Color Indication of Appearance Parts
Example:
(RED) ... KNOB, BALANCE (WHITE)
↑ Cabinet's Color ↑ Parts Color

The components identified by mark or dotted line with mark are critical for safety. Replace only with part number specified.

5-1. CHASSIS SECTION

- A : TRANSFORMER board
- B : POWER SW board
- C : AU BUS board

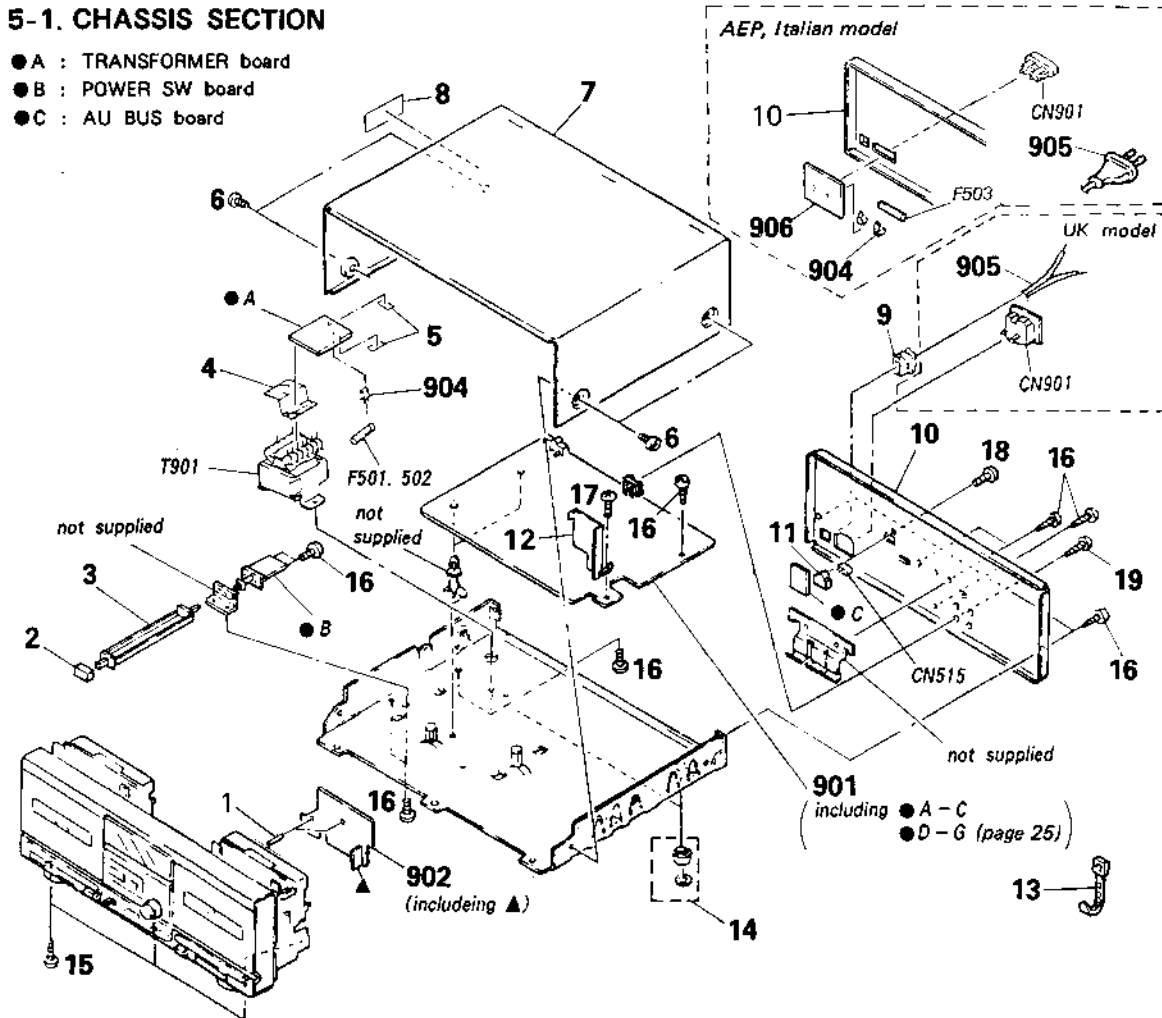

| Ref.No | Part No. | Description | Remark | Ref.No | Part No. | Description | Remark |
|--------|---------------|------------------------------|--------|--------|---------------|--------------------------------------|--------|
| 1 | *3-682-419-21 | HOLDER, P.C.B | | 17 | 7-685-646-79 | SCREW +BVT 3X8 TYPE2 N-S | |
| 2 | 4-922-903-01 | BUTTON (POWER) | | 18 | 7-685-533-11 | SCREW +BTP 2.6X6 TYPE2 N-S | |
| 3 | *3-350-114-01 | LEVER (POWER SW) | | 19 | 7-621-849-00 | SCREW, TAPPING | |
| 4 | *3-337-136-01 | COVER, TRANSFORMER SAFETY | | 901 | *A-2006-125-A | MOUNTED PCB, AUDIO | |
| 5 | *3-701-947-13 | LABEL (T1.6A), FUSE | | 902 | 1-630-423-11 | PC BOARD, HX PRO | |
| 6 | 3-704-366-01 | SCREW (CASE) (M3X8) | | 904 | 1-533-162-00 | HOLDER, FUSE | |
| 7 | 4-919-379-11 | CASE | | 905 | ▲1-555-750-00 | (AEP, Italian)...CORD, POWER | |
| 8 | 3-703-079-21 | (UK)...LABEL, CAUTION (BACK) | | | ▲1-556-562-00 | (UK)...CORD, POWER | |
| 9 | *3-703-244-00 | BUSHING (2104), CORD | | 906 | *1-626-652-11 | (AEP, Italian)...PC BOARD, FUSE | |
| 10 | *3-350-131-41 | (AEP, Italian)...PANEL, BACK | | CN515 | *1-565-562-11 | CONNECTOR (BASE POST) 3P (AU BUS) | |
| | 3-350-131-51 | (UK)...PANEL, BACK | | CN901 | ▲1-526-751-00 | (UK)...OUTLET, AC | |
| 11 | 3-332-819-01 | HOLDER CONNECTOR | | | ▲1-526-794-11 | (AEP, Italian)...OUTLET, AC | |
| 12 | *3-350-123-01 | PLATE (MDB), SHIELD | | F501 | ▲1-532-259-00 | FUSE, TIME-LAG (1.6A) | |
| 13 | *3-337-402-01 | BAND, BINDING | | F502 | ▲1-532-259-00 | FUSE, TIME-LAG (1.6A) | |
| 14 | X-4917-254-1 | FOOT ASSY | | F503 | ▲1-532-078-00 | (AEP, Italian)...FUSE, TIME-LAG (1A) | |
| 15 | 7-682-547-09 | SCREW +BVT 3X6 (S) | | T901 | ▲1-449-460-11 | TRANSFORMER, POWER | |
| 16 | 7-682-547-04 | SCREW +BVT 3X6 (S) | | | | | |

5-2. FRONT PANEL SECTION

- D : CONTROL SW (A) board
- E : CONTROL SW (B) board
- F : FL board
- G : REC VOL board

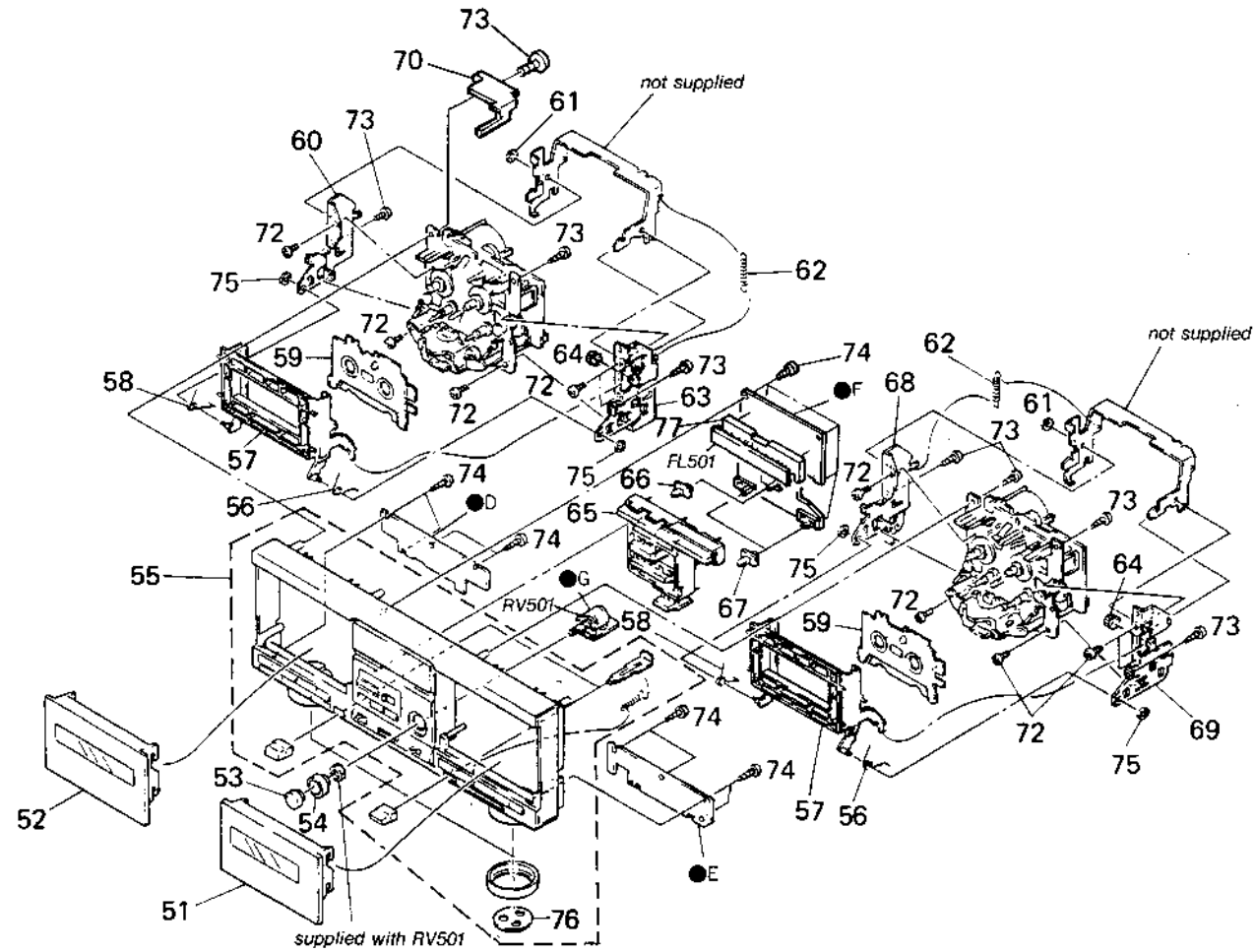

| Ref.No | Part No. | Description | Remark | Ref.No | Part No. | Description | Remark |
|--------|---------------|--------------------------|--------|--------|---------------|--------------------------------------|--------|
| 51 | 3-343-686-31 | LID, CASSETTE (DECK B) | | 64 | X-3332-464-1 | GEAR (DAMPER) ASSY | |
| 52 | 3-343-686-21 | LID, CASSETTE (DECK A) | | 65 | X-3343-632-1 | BUTTON (C) ASSY | |
| 53 | 3-343-633-01 | KNOB (φ21) (REC LEVEL R) | | 66 | 4-922-518-11 | KNOB (AUTO CD SYNCHRO; MODE) | |
| 54 | 3-343-634-01 | KNOB (φ23) (REC LEVEL L) | | 67 | 4-924-444-11 | KNOB (DIRECTION MODE/DOLBY NR) | |
| 55 | X-3343-636-1 | PANEL ASSY, FRONT | | 68 | *X-3343-626-1 | BRACKET (LB) ASSY | |
| 56 | 3-343-688-01 | SPRING (LOADING RIGHT) | | 69 | *X-3343-627-1 | BRACKET (RB) ASSY | |
| 57 | X-3343-628-1 | HOLDER ASSY, CASSETTE | | 70 | *3-350-117-01 | REINFORCEMENT (FP) | |
| 58 | 3-343-687-01 | SPRING (LOADING LEFT) | | 72 | 7-621-770-87 | SCREW +BVT 2.6X5 (S) | |
| 59 | *3-340-123-01 | RETAINER, CASSETTE | | 73 | 7-685-134-19 | SCREW +P 2.6X8 TYPE2 NON-SLIT | |
| 60 | *X-3343-624-1 | BRACKET (LA) ASSY | | 74 | 7-685-533-11 | SCREW +BTP 2.6X6 TYPE2 N-S | |
| 61 | 7-624-105-04 | STOP RING 2,3, TYPE -E | | 75 | 7-624-190-31 | STOP RING 4, TYPE-CS | |
| 62 | 3-343-689-01 | SPRING, TENSION | | 76 | 4-928-401-11 | FELT | |
| 63 | *X-3343-625-1 | BRACKET (RA) ASSY | | 77 | 3-350-116-02 | HOLDER (FL) | |
| | | | | FL501 | 1-519-493-11 | INDICATOR TUBE, FLUORESCENT | |
| | | | | RV501 | 1-238-300-11 | RES, VAR, CARBON 10K/10K (REC LEVEL) | |

5-3. MECH

- TCM-17
- TCM-17



| No. | Part No. | Description | Remark |
|-----|-------------|-------------|--------|
| 151 | *X-3343-471 | | |
| 152 | 3-343-471 | | |
| 153 | *3-343-471 | | |
| 154 | 7-685-101 | | |
| 155 | X-3343-471 | | |
| 156 | 7-621-770 | | |
| 157 | 3-343-401 | | |
| 158 | X-3343-471 | | |
| 159 | 3-343-431 | | |
| 160 | X-3343-471 | | |

ION

ard
ard

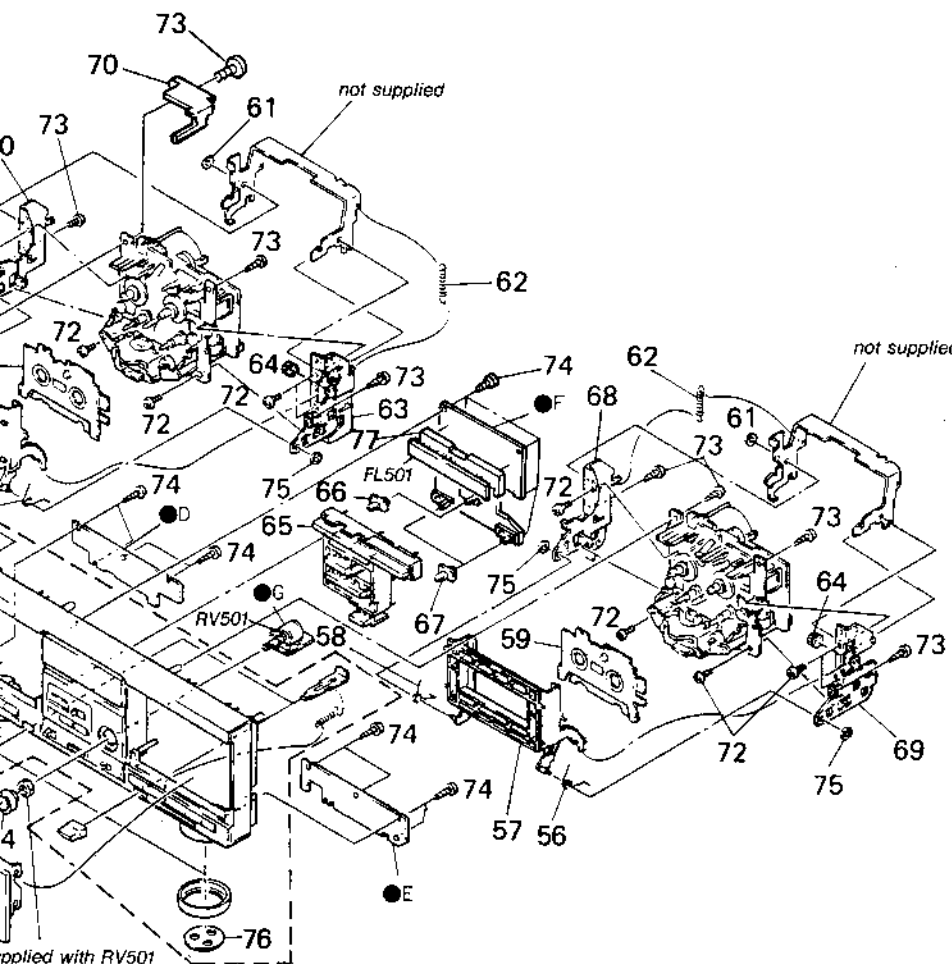

5-3. MECHANISM SECTION 1

TCM-170RA4 : DECK A

TCM-170RB10 : DECK B

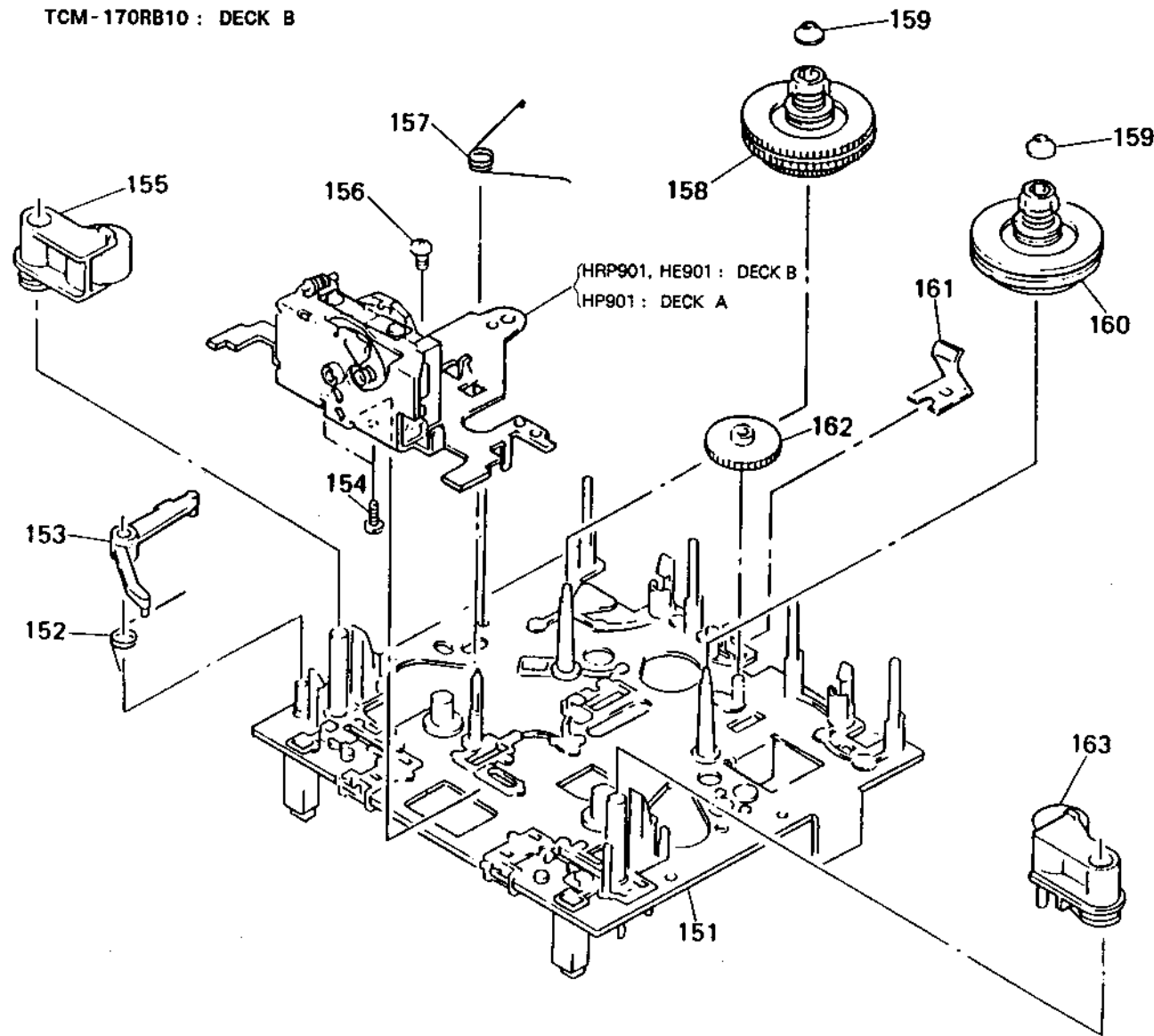

(DECK B)
(DECK A)
(REC LEVEL R)
(REC LEVEL L)
FRONT
(ING RIGHT)
CASSETTE
(ING LEFT)
CASSETTE
ASSY
, TYPE -E
ION
ASSY

| Remark | Ref.No | Part No. | Description | Remark |
|--------|--------|---------------|--------------------------------------|--------|
| | 64 | X-3332-464-1 | GEAR (DAMPER) ASSY | |
| | 65 | X-3343-632-1 | BUTTON (C) ASSY | |
| | 66 | 4-922-518-11 | KNOB (AUTO CD SYNCHRO; MODE) | |
| | 67 | 4-924-444-11 | KNOB (DIRECTION MODE/DOLBY NR) | |
| | 68 | *X-3343-626-1 | BRACKET (LB) ASSY | |
| | 69 | *X-3343-627-1 | BRACKET (RB) ASSY | |
| | 70 | *3-350-117-01 | REINFORCEMENT (FP) | |
| | 72 | 7-621-770-87 | SCREW +BYTT 2.6X5 (S) | |
| | 73 | 7-685-134-19 | SCREW +P 2.6X8 TYPE2 NON-SLIT | |
| | 74 | 7-685-533-11 | SCREW +BTP 2.6X6 TYPE2 N-S | |
| | 75 | 7-624-190-31 | STOP RING 4, TYPE-CS | |
| | 76 | 4-928-401-11 | FELT | |
| | 77 | 3-350-116-02 | HOLDER (FL) | |
| | FL501 | 1-519-493-11 | INDICATOR TUBE, FLUORESCENT | |
| | RV501 | 1-238-300-11 | RES, VAR, CARBON 10K/10K (REC LEVEL) | |

| No. | Part No. | Description |
|-----|---------------|-------------------------------|
| 151 | *X-3343-439-1 | CHASSIS ASSY, MECHANICAL |
| 152 | 3-343-477-01 | SPRING, TORSION (EJECT SAFTY) |
| 153 | *3-343-476-01 | LEVER (EJECT SAFETY LEVER) |
| 154 | 7-685-102-19 | SCREW +P 2X4 NON-SLIT TYPE 2 |
| 155 | X-3343-403-1 | LEVER (PINCH LEVER REV) ASSY |
| 156 | 7-621-773-86 | SCREW +BYTT 2.6X4 (S) |
| 157 | 3-343-401-01 | SPRING, TORSION |
| 158 | X-3343-415-1 | TABEL (REV) ASSY, REEL |
| 159 | 3-343-439-01 | CAP (REEL TABLE) |
| 160 | X-3343-401-1 | TABEL ASSY, REEL |

| Remarks | No. | Part No. | Description | Remarks |
|---------|--------|--------------|-------------------------------|---------|
| | 161 | 3-343-420-01 | SPRING, LEAF | |
| | 162 | 3-343-411-01 | GEAR (FF GEAR) | |
| | 163 | X-3343-402-1 | LEVER (PINCH LEVER FWD) ASSY | |
| | HP901 | A-2108-129-A | (DECK A)...CHASSIS ASSY, HEAD | |
| | HE901 | A-2108-124-A | (DECK B)...CHASSIS ASSY, HEAD | |
| | HRP901 | | | |

5-4. MECHANISM SECTION 2

TCM-170RA4 : DECK A
TCM-170RB10 : DECK B

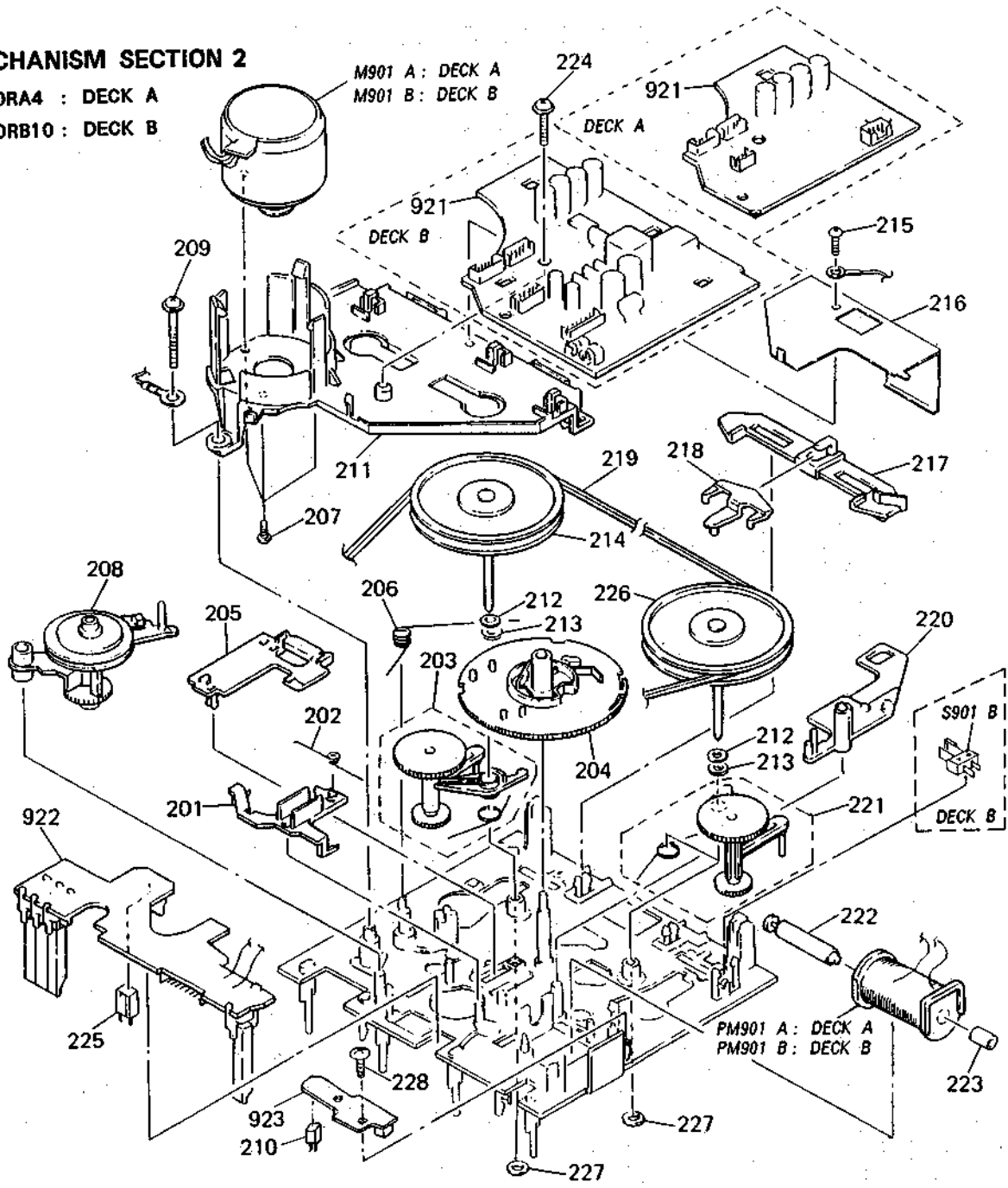

| No. | Part No. | Description | Remarks | No. | Part No. | Description | Remarks |
|-----|---------------|-----------------------------|---------|---------|---------------|----------------------------------|---------|
| 201 | 3-343-453-01 | SLIDER (BRAKE PLATE) | | 221 | X-3343-405-1 | LEVER (TU ARM FWD) ASSY | |
| 202 | 3-343-429-01 | SPRING, TORSION | | 222 | *3-343-425-01 | ARBOR(MOVABLE IRON ARBOR), IRON | |
| 203 | X-3343-406-1 | LEVER (TU ARM REV) ASSY | | 223 | *3-343-424-01 | ARBOR (FIXED IRON ARBOR), IRON | |
| 204 | 3-343-470-01 | GEAR (CAM GEAR) | | 224 | 3-343-404-01 | SCREW (PTPWH 2X10) | |
| 205 | *3-343-461-01 | SLIDER | | 225 | *3-343-419-01 | HOLDER (S SENSOR A) | |
| 206 | 3-343-430-01 | SPRING, TORSION | | 226 | X-3343-431-1 | FLYWHEEL (REV) COMPLETE ASSY | |
| 207 | 7-627-556-28 | SCREW +P 2.6X3.5 | | 227 | 3-343-473-01 | WASHER, NYLON | |
| 208 | X-3343-414-1 | LAYER (FR ARM) ASSY | | 228 | 7-685-103-19 | SCREW + PTPWH (2X5) | |
| 209 | 3-343-403-01 | SCREW (PTTWH 2X18) | | 921 | *1-624-147-11 | (DECK A)...PC BOARD, MD (A) | |
| 210 | *3-343-491-01 | HOLDER (S SENSOR B) | | | *1-629-211-11 | (DECK B)...PC BOARD, MD (B) | |
| 211 | *X-3343-407-1 | BASE (THRUST RETAINER) ASSY | | 922 | *1-624-148-11 | PC BOARD, LEAF SW | |
| 212 | 4-605-835-11 | WASHER (2.6), POLYSLIDER | | 923 | *1-628-656-11 | PC BOARD, REEL SENSOR | |
| 213 | 3-307-482-00 | WASHER, LUMILER | | M901-A | X-3343-408-1 | (DECK A)...MOTOR ASSY | |
| 214 | X-3343-429-1 | FLYWHEEL COMPLETE ASSY | | M901-B | X-3343-408-1 | (DECK B)...MOTOR ASSY | |
| 215 | 7-685-104-19 | SCREW +P 2X6 TYPE2 NON-SLIT | | PM901-A | 1-454-456-11 | (DECK A)...SOLENOID, PLUNGER | |
| 216 | 3-343-480-01 | PLATE, SHIELD | | PM901-B | 1-454-456-11 | (DECK B)...SOLENOID, PLUNGER | |
| 217 | *3-343-457-01 | SLIDER (REVERSE SLIDER) | | S901-B | 1-571-028-11 | (DECK B)...SWITCH, LEAF (REC SW) | |
| 218 | 3-343-462-01 | LEVER | | | | | |
| 219 | 3-343-426-02 | BELT (CAPSTAN BELT SQUARE) | | | | | |
| 220 | 3-343-493-01 | LEVER (PM LEVER) | | | | | |

SECTION 6 ELECTRICAL PARTS LIST

NOTE:

- Due to standardization, replacements in the parts list may be different from the parts specified in the diagrams or the components used on the set.
- Items marked "*" are not stocked since they are seldom required for routine service. Some delay should be anticipated when ordering these items.
- If there are two or more same circuits in a set such as a stereophonic machine, only typical circuit parts may be indicated and capacitors and resistors in other same circuits may be omitted.

CAPACITORS:

MF: μ F, PF: μ MF.

RESISTORS

- All resistors are in ohms.
- F: nonflammable

COILS

- MMH: mH, UH: μ H

SEMICONDUCTORS

In each case, U: μ , for example:

UA.... μ A...., UPA.... μ PA....,
UPC.... μ PC, UPD.... μ PD....

The components identified by mark or dotted line with mark are critical for safety. Replace only with part number specified.

| Ref.No | Part No. | Description | | | | |
|------------------|---------------|---------------------------------|----------|-------|------|--|
| 901 | *A-2006-125-A | MOUNTED PCB, AUDIO | | | | |
| 902 | *1-630-423-11 | PC BOARD, HX PRO | | | | |
| 904 | 1-533-162-00 | HOLDER, FUSE | | | | |
| 905 | 1-555-750-00 | (AEP, Italian)...CORD, POWER | | | | |
| | 1-555-562-00 | (UK)...CORD, POWER | | | | |
| 906 | *1-626-652-11 | (AEP, Italian)...PC BOARD, FUSE | | | | |
| 921 | *1-624-147-11 | (DECK A)...PC BOARD, MD (A) | | | | |
| | *1-629-211-11 | (DECK B)...PC BOARD, MD (B) | | | | |
| 922 | *1-624-148-11 | PC BOARD, LEAF SW | | | | |
| 923 | *1-628-656-11 | PC BOARD, REEL SENSOR | | | | |
| CAPACITOR | | | | | | |
| C21 | 1-124-902-00 | ELECT | 0.47MF | 20% | 50V | |
| C41A | 1-162-289-31 | CERAMIC | 390PF | 10% | 50V | |
| C41B | 1-130-469-00 | MYLAR | 880PF | 5% | 50V | |
| C42A | 1-136-157-00 | FILM | 0.022MF | 5% | 50V | |
| C42B | 1-136-157-00 | FILM | 0.022MF | 5% | 50V | |
| C43A | 1-124-282-00 | ELECT | 22MF | 20% | 25V | |
| C43B | 1-124-282-00 | ELECT | 22MF | 20% | 25V | |
| C44 | 1-162-285-31 | CERAMIC | 180PF | 10% | 50V | |
| C45 | 1-107-210-00 | MICA | 22PF | 5% | 500V | |
| C51 | 1-136-153-00 | FILM | 0.01MF | 5% | 50V | |
| C52 | 1-136-157-00 | FILM | 0.022MF | 5% | 50V | |
| C53 | 1-136-165-00 | FILM | 0.1MF | 5% | 50V | |
| C54 | 1-136-433-11 | FILM | 100PF | 5% | 630V | |
| C55 | 1-136-433-11 | FILM | 100PF | 5% | 630V | |
| C56 | 1-130-468-00 | MYLAR | 560PF | 5% | 50V | |
| C61A | 1-162-289-31 | CERAMIC | 390PF | 10% | 50V | |
| C61B | 1-130-469-00 | MYLAR | 880PF | 5% | 50V | |
| C62A | 1-136-157-00 | FILM | 0.022MF | 5% | 50V | |
| C62B | 1-136-157-00 | FILM | 0.022MF | 5% | 50V | |
| C63A | 1-124-282-00 | ELECT | 22MF | 20% | 25V | |
| C63B | 1-124-282-00 | ELECT | 22MF | 20% | 25V | |
| C64 | 1-162-285-31 | CERAMIC | 180PF | 10% | 50V | |
| C65 | 1-107-210-00 | MICA | 22PF | 5% | 500V | |
| C71 | 1-136-153-00 | FILM | 0.01MF | 5% | 50V | |
| C72 | 1-136-157-00 | FILM | 0.022MF | 5% | 50V | |
| C73 | 1-136-165-00 | FILM | 0.1MF | 5% | 50V | |
| C74 | 1-136-433-11 | FILM | 100PF | 5% | 630V | |
| C75 | 1-136-433-11 | FILM | 100PF | 5% | 630V | |
| C76 | 1-130-468-00 | MYLAR | 560PF | 5% | 50V | |
| C81A | 1-126-101-11 | ELECT | 100MF | 20% | 16V | |
| C81B | 1-124-443-00 | ELECT | 100MF | 20% | 10V | |
| C82A | 1-126-101-11 | ELECT | 100MF | 20% | 16V | |
| C82B | 1-124-443-00 | ELECT | 100MF | 20% | 10V | |
| C84B | 1-123-875-11 | ELECT | 10MF | 20% | 50V | |
| C85B | 1-130-856-00 | FILM | 0.0068MF | 5% | 100V | |
| C86B | 1-136-230-00 | FILM | 0.0022MF | 5% | 100V | |
| C87B | 1-136-230-00 | FILM | 0.0022MF | 5% | 100V | |
| C88B | 1-136-558-11 | FILM | 0.0039MF | 5% | 630V | |
| C90B | 1-126-101-11 | ELECT | 100MF | 20% | 16V | |
| C91B | 1-161-375-00 | CERAMIC | 0.0022MF | 30% | 16V | |
| C92 | 1-126-101-11 | ELECT | 100MF | 20% | 16V | |
| C93 | 1-124-446-11 | ELECT | 47MF | 20% | 10V | |
| C94 | 1-107-046-00 | MICA | 4.7PF | 0.5PF | 500V | |

| Ref.No | Part No. | Description | | | | |
|--------|--------------|-------------|----------|-----|-----|--|
| C101 | 1-124-925-11 | ELECT | 2.2MF | 20% | 50V | |
| C102 | 1-124-925-11 | ELECT | 2.2MF | 20% | 50V | |
| C103 | 1-124-925-11 | ELECT | 2.2MF | 20% | 50V | |
| C104 | 1-124-925-11 | ELECT | 2.2MF | 20% | 50V | |
| C105 | 1-124-927-11 | ELECT | 4.7MF | 20% | 50V | |
| C106 | 1-124-927-11 | ELECT | 4.7MF | 20% | 50V | |
| C107 | 1-136-156-00 | FILM | 0.018MF | 5% | 50V | |
| C108 | 1-124-927-11 | ELECT | 4.7MF | 20% | 50V | |
| C109 | 1-130-479-00 | MYLAR | 0.0047MF | 5% | 50V | |
| C110 | 1-136-173-00 | FILM | 0.47MF | 5% | 50V | |
| C111 | 1-136-167-00 | FILM | 0.15MF | 5% | 50V | |
| C112 | 1-136-155-00 | FILM | 0.015MF | 5% | 50V | |
| C113 | 1-136-169-00 | FILM | 0.22MF | 5% | 50V | |
| C114 | 1-136-163-00 | FILM | 0.068MF | 5% | 50V | |
| C115 | 1-136-161-00 | FILM | 0.047MF | 5% | 50V | |
| C116 | 1-130-481-00 | MYLAR | 0.0068MF | 5% | 50V | |
| C117 | 1-136-153-00 | FILM | 0.01MF | 5% | 50V | |
| C118 | 1-124-927-11 | ELECT | 4.7MF | 20% | 50V | |
| C119 | 1-124-767-00 | ELECT | 2.2MF | 20% | 50V | |
| C121 | 1-124-927-11 | ELECT | 4.7MF | 20% | 50V | |
| C122 | 1-124-927-11 | ELECT | 4.7MF | 20% | 50V | |
| C123 | 1-124-477-11 | ELECT | 47MF | 20% | 16V | |
| C124 | 1-136-159-00 | FILM | 0.033MF | 5% | 50V | |
| C125 | 1-130-481-00 | MYLAR | 0.0068MF | 5% | 50V | |
| C129 | 1-130-482-00 | MYLAR | 0.0082MF | 5% | 50V | |
| C130 | 1-130-473-00 | MYLAR | 0.0015MF | 5% | 50V | |
| C133 | 1-130-472-00 | MYLAR | 0.0012MF | 5% | 50V | |
| C135 | 1-136-156-00 | FILM | 0.018MF | 5% | 50V | |
| C136 | 1-130-477-00 | MYLAR | 0.0033MF | 5% | 50V | |
| C137 | 1-130-472-00 | MYLAR | 0.0012MF | 5% | 50V | |
| C138 | 1-162-285-31 | CERAMIC | 180PF | 10% | 50V | |
| C201 | 1-124-925-11 | ELECT | 2.2MF | 20% | 50V | |
| C202 | 1-124-925-11 | ELECT | 2.2MF | 20% | 50V | |
| C203 | 1-124-925-11 | ELECT | 2.2MF | 20% | 50V | |
| C204 | 1-124-925-11 | ELECT | 2.2MF | 20% | 50V | |
| C205 | 1-124-927-11 | ELECT | 4.7MF | 20% | 50V | |
| C206 | 1-124-927-11 | ELECT | 4.7MF | 20% | 50V | |
| C207 | 1-136-156-00 | FILM | 0.018MF | 5% | 50V | |
| C208 | 1-124-927-11 | ELECT | 4.7MF | 20% | 50V | |
| C209 | 1-130-479-00 | MYLAR | 0.0047MF | 5% | 50V | |
| C210 | 1-136-173-00 | FILM | 0.47MF | 5% | 50V | |
| C211 | 1-136-167-00 | FILM | 0.15MF | 5% | 50V | |
| C212 | 1-136-155-00 | FILM | 0.015MF | 5% | 50V | |
| C213 | 1-136-169-00 | FILM | 0.22MF | 5% | 50V | |
| C214 | 1-136-163-00 | FILM | 0.068MF | 5% | 50V | |
| C215 | 1-136-161-00 | FILM | 0.047MF | 5% | 50V | |
| C216 | 1-130-481-00 | MYLAR | 0.0068MF | 5% | 50V | |
| C217 | 1-136-153-00 | FILM | 0.01MF | 5% | 50V | |
| C218 | 1-124-927-11 | ELECT | 4.7MF | 20% | 50V | |
| C219 | 1-124-767-00 | ELECT | 2.2MF | 20% | 50V | |
| C221 | 1-124-927-11 | ELECT | 4.7MF | 20% | 50V | |
| C222 | 1-124-927-11 | ELECT | 4.7MF | 20% | 50V | |
| C223 | 1-124-477-11 | ELECT | 47MF | 20% | 16V | |
| C224 | 1-136-159-00 | FILM | 0.033MF | 5% | 50V | |
| C225 | 1-130-481-00 | MYLAR | 0.0068MF | 5% | 50V | |

| Ref.No | Part No. | Description | | | |
|--------|---------------|-----------------------------------|----------|-----|------|
| C229 | 1-130-482-00 | MYLAR | 0.0082MF | 5% | 50V |
| C230 | 1-130-473-00 | MYLAR | 0.0015MF | 5% | 50V |
| C233 | 1-130-472-00 | MYLAR | 0.0012MF | 5% | 50V |
| C235 | 1-136-156-00 | FILM | 0.018MF | 5% | 50V |
| C236 | 1-130-477-00 | MYLAR | 0.0033MF | 5% | 50V |
| C237 | 1-130-472-00 | MYLAR | 0.0012MF | 5% | 50V |
| C238 | 1-162-285-31 | CERAMIC | 180PF | 10% | 50V |
| C501 | 1-124-477-11 | ELECT | 47MF | 20% | 16V |
| C502 | 1-124-477-11 | ELECT | 47MF | 20% | 16V |
| C503 | 1-124-477-11 | ELECT | 47MF | 20% | 16V |
| C504 | 1-124-477-11 | ELECT | 47MF | 20% | 16V |
| C505 | 1-124-477-11 | ELECT | 47MF | 20% | 16V |
| C506 | 1-124-477-11 | ELECT | 47MF | 20% | 16V |
| C507 | 1-124-477-11 | ELECT | 47MF | 20% | 16V |
| C508 | 1-124-477-11 | ELECT | 47MF | 20% | 16V |
| C509 | 1-124-477-11 | ELECT | 47MF | 20% | 16V |
| C510 | 1-124-477-11 | ELECT | 47MF | 20% | 16V |
| C511 | 1-124-925-11 | ELECT | 2.2MF | 20% | 50V |
| C512 | 1-136-157-00 | FILM | 0.022MF | 5% | 50V |
| C513 | 1-124-925-11 | ELECT | 2.2MF | 20% | 50V |
| C514 | 1-124-925-11 | ELECT | 2.2MF | 20% | 50V |
| C515 | 1-124-499-11 | ELECT | 1MF | 20% | 50V |
| C516 | 1-124-360-00 | ELECT | 1000MF | 20% | 16V |
| C517 | 1-124-360-00 | ELECT | 1000MF | 20% | 16V |
| C518 | 1-124-360-00 | ELECT | 1000MF | 20% | 16V |
| C519 | 1-124-477-11 | ELECT | 47MF | 20% | 16V |
| C520 | 1-124-556-11 | ELECT | 2200MF | 20% | 16V |
| C521 | 1-124-887-00 | ELECT | 3300MF | 20% | 16V |
| C522 | 1-124-911-11 | ELECT | 220MF | 20% | 50V |
| C523 | 1-123-875-11 | ELECT | 10MF | 20% | 50V |
| C524 | 1-124-927-11 | ELECT | 4.7MF | 20% | 50V |
| C525 | 1-123-875-11 | ELECT | 10MF | 20% | 50V |
| C526 | 1-124-925-11 | ELECT | 2.2MF | 20% | 50V |
| C527 | 1-124-472-11 | ELECT | 470MF | 20% | 6.3V |
| C528 | 1-124-927-11 | ELECT | 4.7MF | 20% | 50V |
| C529 | 1-161-494-00 | CERAMIC | 0.022MF | | 25V |
| C530 | 1-161-494-00 | CERAMIC | 0.022MF | | 25V |
| C531 | 1-161-494-00 | CERAMIC | 0.022MF | | 25V |
| C532 | 1-161-494-00 | CERAMIC | 0.022MF | | 25V |
| C533 | 1-161-494-00 | CERAMIC | 0.022MF | | 25V |
| C534 | 1-124-499-11 | ELECT | 1MF | 20% | 50V |
| C801 | 1-126-176-11 | ELECT | 220MF | 20% | 10V |
| C802 | 1-124-925-11 | ELECT | 2.2MF | 20% | 50V |
| C803 | 1-124-927-11 | ELECT | 4.7MF | 20% | 50V |
| C805 | 1-124-477-11 | ELECT | 47MF | 20% | 16V |
| C812 | 1-126-176-11 | ELECT | 220MF | 20% | 10V |
| CN501 | *1-564-708-11 | PIN, CONNECTOR (SMALL TYPE) 6P | | | |
| CN502 | *1-564-341-11 | PIN, CONNECTOR 7P | | | |
| CN503 | *1-506-503-11 | PIN, CONNECTOR 9P | | | |
| CN504 | *1-564-338-00 | PIN, CONNECTOR 4P | | | |
| CN505 | *1-564-342-61 | PIN, CONNECTOR 8P | | | |
| CN506 | *1-564-341-71 | PIN, CONNECTOR 7P | | | |
| CN507 | *1-564-342-11 | PIN, CONNECTOR 8P | | | |
| CN512 | *1-564-338-00 | PIN, CONNECTOR 4P | | | |
| CN515 | *1-565-562-11 | CONNECTOR (BASE POST) 3P (AU BUS) | | | |
| CN516 | *1-564-496-11 | PIN, CONNECTOR 3P | | | |
| CN901 | ▲1-526-751-00 | (UK).....OUTLET, AC | | | |
| | ▲1-526-794-11 | (AEP).....OUTLET, AC | | | |
| CNP11A | *1-564-501-11 | PIN, CONNECTOR 8P | | | |
| CNP11B | *1-506-615-11 | PIN, CONNECTOR 9P | | | |
| CNP12A | *1-564-338-00 | PIN, CONNECTOR 4P | | | |
| CNP12B | *1-564-341-11 | PIN, CONNECTOR 7P | | | |
| CNP13A | *1-564-707-11 | PIN, CONNECTOR (SMALL TYPE) 5P | | | |
| CNP13B | *1-564-707-11 | PIN, CONNECTOR (SMALL TYPE) 5P | | | |

| Ref.No | Part No. | Description |
|--------|---------------|---------------------------------|
| CNP14B | *1-564-704-11 | PIN, CONNECTOR (SMALL TYPE) 2P |
| CNP16A | *1-564-337-00 | PIN, CONNECTOR 3P |
| CNP16B | *1-564-337-00 | PIN, CONNECTOR 3P |
| CNP18A | *1-564-496-11 | PIN, CONNECTOR 3P |
| CNP18B | *1-564-496-11 | PIN, CONNECTOR 3P |
| CNP21B | *1-565-344-11 | PIN, CONNECTOR (PC BOARD) 8P |
| CNP22 | *1-565-347-11 | SOCKET, CONNECTOR (PC BOARD) 8P |
| CNP81A | *1-564-706-11 | PIN, CONNECTOR (SMALL TYPE) 4P |
| CNP81B | *1-564-709-11 | PIN, CONNECTOR (SMALL TYPE) 7P |
| CNP82A | *1-564-339-00 | PIN, CONNECTOR 5P |
| CNP82B | *1-564-339-61 | PIN, CONNECTOR 5P |
| CNP83 | *1-564-338-00 | PIN, CONNECTOR 4P |
| CP501 | 1-233-167-11 | COMPOSITION CIRCUIT BLOCK |
| CP502 | 1-233-166-11 | COMPOSITION CIRCUIT BLOCK |
| D11A | 8-719-107-94 | DIODE 1SS132 |
| D11B | 8-719-107-94 | DIODE 1SS132 |
| D81B | 8-719-107-94 | DIODE 1SS132 |
| D101 | 8-719-912-20 | DIODE 1SS120 |
| D201 | 8-719-912-20 | DIODE 1SS120 |
| D503 | 8-719-200-77 | DIODE 10E2N |
| D504 | 8-719-200-77 | DIODE 10E2N |
| D505 | 8-719-200-77 | DIODE 10E2N |
| D506 | 8-719-200-77 | DIODE 10E2N |
| D507 | 8-719-912-20 | DIODE 1SS120 |
| D508 | 8-719-933-33 | DIODE HZS6A1L |
| D509 | 8-719-933-33 | DIODE HZS6A1L |
| D510 | 8-719-912-20 | DIODE 1SS120 |
| D511 | 8-719-200-77 | DIODE 10E2N |
| D512 | 8-719-200-77 | DIODE 10E2N |
| D513 | 8-719-200-77 | DIODE 10E2N |
| D514 | 8-719-912-20 | DIODE 1SS120 |
| D515 | 8-719-912-20 | DIODE 1SS120 |
| D516 | 8-719-912-20 | DIODE 1SS120 |
| D517 | 8-719-912-20 | DIODE 1SS120 |
| D519 | 8-719-933-33 | DIODE HZS6A1L |
| D520 | 8-719-912-20 | DIODE 1SS120 |
| D521 | 8-719-912-20 | DIODE 1SS120 |
| D522 | 8-719-912-20 | DIODE 1SS120 |
| D523 | 8-719-000-51 | DIODE UZL-6L2 |
| D524 | 8-719-912-20 | DIODE 1SS120 |
| D525 | 8-719-200-77 | DIODE 10E2N |
| D801 | 8-719-300-71 | DIODE SEL2210R |
| D802 | 8-719-304-85 | DIODE SEL2410G-D |
| D803 | 8-719-300-71 | DIODE SEL2210R |
| D804 | 8-719-300-71 | DIODE SEL2210R |
| D805 | 8-719-300-71 | DIODE SEL2210R |
| D806 | 8-719-311-61 | DIODE SEL2810D-D |
| D807 | 8-719-312-29 | DIODE SEL4826D-C |
| D808 | 8-719-311-70 | DIODE SEL4825D-C |
| D809 | 8-719-311-70 | DIODE SEL4825D-C |
| D810 | 8-719-304-96 | DIODE SEL4425G-C |
| D811 | 8-719-311-70 | DIODE SEL4825D-C |
| D812 | 8-719-311-70 | DIODE SEL4825D-C |
| D813 | 8-719-304-96 | DIODE SEL4425G-C |
| D814 | 8-719-312-29 | DIODE SEL4826D-C |
| D815 | 8-719-312-30 | DIODE SEL4226R-C |
| D816 | 8-719-912-20 | DIODE 1SS120 |
| D817 | 8-719-912-20 | DIODE 1SS120 |
| D818 | 8-719-200-77 | DIODE 10E2N |
| D819 | 8-719-200-77 | DIODE 10E2N |
| D820 | 8-719-200-77 | DIODE 10E2N |
| D822 | 8-719-912-20 | DIODE 1SS120 |
| D823 | 8-719-912-20 | DIODE 1SS120 |
| D824 | 8-719-912-20 | DIODE 1SS120 |

Note: The components identified by mark ▲ or dotted line with mark ▲ are critical for safety. Replace only with part number specified.

| Ref.No | Part No. | Description |
|---------|---------------------------|---------------------------------------|
| D825 | 8-719-912-20 | DIODE 1SS120 |
| D826 | 8-719-912-20 | DIODE 1SS120 |
| D827 | 8-719-912-20 | DIODE 1SS120 |
| D828 | 8-719-912-20 | DIODE 1SS120 |
| F301 | △ 1-532-675-00 | LINK, IC |
| F501 | △ 1-532-259-00 | FUSE, TIME-LAG (1.6A) |
| F502 | △ 1-532-259-00 | FUSE, TIME-LAG (1.6A) |
| F503 | △ 1-532-078-00 | (AEP, Italian)... FUSE, TIME-LAG (1A) |
| FL501 | 1-519-493-11 | INDICATOR TUBE, FLUORESCENT |
| HE901 | A-2108-124-A (DECK B).... | CHASSIS ASSY, HEAD |
| HP901 | A-2108-129-A (DECK A).... | CHASSIS ASSY, HEAD |
| HRP901 | A-2108-124-A (DECK B).... | CHASSIS ASSY, HEAD |
| IC21 | 8-759-133-90 | IC UPC339C |
| IC81A | 8-759-111-44 | IC UPC4570C-1 |
| IC81B | 8-759-111-44 | IC UPC4570C-1 |
| IC91 | 8-759-106-56 | IC UPC1297CA |
| IC501 | 8-759-601-02 | IC M5218P |
| IC502 | 8-759-601-02 | IC M5218P |
| IC503 | 8-759-601-43 | IC M4066BP |
| IC504 | 8-759-601-02 | IC M5218P |
| IC505 | 8-759-601-41 | IC M4053BP |
| IC506 | 8-752-018-70 | IC CX20187 |
| IC507 | 8-759-601-02 | IC M5218P |
| IC509 | 8-759-601-23 | IC M4023BP |
| IC510 | 8-759-945-58 | IC RC4558P |
| IC511 | 8-759-601-02 | IC M5218P |
| IC801 | 8-759-979-32 | IC MB88517B-659N |
| IC802 | 8-759-601-38 | IC M4050BP |
| IC803 | 8-759-633-22 | IC M50964-210SP |
| J501 | 1-565-258-11 | JACK, PIN 4P (LINE IN/OUT) |
| L41 | 1-410-780-11 | INDUCTOR 27MMH |
| L61 | 1-410-780-11 | INDUCTOR 27MMH |
| L101 | 1-410-775-21 | INDUCTOR 10MMH |
| L102 | 1-410-775-21 | INDUCTOR 10MMH |
| L201 | 1-410-775-21 | INDUCTOR 10MMH |
| L202 | 1-410-775-21 | INDUCTOR 10MMH |
| LPF101 | 1-236-147-11 | FILTER, LOW PASS |
| LPF201 | 1-236-147-11 | FILTER, LOW PASS |
| M901-A | X-3343-408-1 (DECK A).... | MOTOR ASSY |
| M901-B | X-3343-408-1 (DECK B).... | MOTOR ASSY |
| PM901-A | 1-454-456-11 (DECK A).... | SOLENOID, PLUNGER |
| PM901-B | 1-454-456-11 (DECK B).... | SOLENOID, PLUNGER |
| Q11A | 8-729-119-76 | TRANSISTOR 2SA1175-HFE |
| Q11B | 8-729-119-76 | TRANSISTOR 2SA1175-HFE |
| Q12A | 8-719-939-23 | GP2S09-C |
| Q12B | 8-719-939-23 | GP2S09-C |
| Q14A | 8-719-939-23 | GP2S09-C |
| Q14B | 8-719-939-23 | GP2S09-C |
| Q21 | 8-729-806-20 | TRANSISTOR 2SA1345 |
| Q81B | 8-729-116-57 | TRANSISTOR 2SB1013 |
| Q82B | 8-729-194-57 | TRANSISTOR 2SC945P |
| Q83B | 8-729-194-57 | TRANSISTOR 2SC945P |
| Q101 | 8-729-806-28 | TRANSISTOR 2SC3402 |
| Q102 | 8-729-806-28 | TRANSISTOR 2SC3402 |
| Q103 | 8-729-806-28 | TRANSISTOR 2SC3402 |
| Q104 | 8-729-806-28 | TRANSISTOR 2SC3402 |
| Q105 | 8-729-806-28 | TRANSISTOR 2SC3402 |
| Q108 | 8-729-900-74 | TRANSISTOR DTC143TS |
| Q109 | 8-729-806-28 | TRANSISTOR 2SC3402 |

| Ref.No | Part No. | Description |
|--------|--------------|------------------------|
| Q110 | 8-729-900-74 | TRANSISTOR DTC143TS |
| Q111 | 8-729-119-78 | TRANSISTOR 2SC2785-HFE |
| Q112 | 8-729-119-78 | TRANSISTOR 2SC2785-HFE |
| Q113 | 8-729-119-78 | TRANSISTOR 2SC2785-HFE |
| Q114 | 8-729-119-78 | TRANSISTOR 2SC2785-HFE |
| Q115 | 8-729-119-78 | TRANSISTOR 2SC2785-HFE |
| Q117 | 8-729-119-78 | TRANSISTOR 2SC2785-HFE |
| Q118 | 8-729-119-78 | TRANSISTOR 2SC2785-HFE |
| Q119 | 8-729-806-28 | TRANSISTOR 2SC3402 |
| Q201 | 8-729-806-28 | TRANSISTOR 2SC3402 |
| Q202 | 8-729-806-28 | TRANSISTOR 2SC3402 |
| Q203 | 8-729-806-28 | TRANSISTOR 2SC3402 |
| Q204 | 8-729-806-28 | TRANSISTOR 2SC3402 |
| Q205 | 8-729-806-28 | TRANSISTOR 2SC3402 |
| Q208 | 8-729-900-74 | TRANSISTOR DTC143TS |
| Q209 | 8-729-806-28 | TRANSISTOR 2SC3402 |
| Q210 | 8-729-900-74 | TRANSISTOR DTC143TS |
| Q211 | 8-729-119-78 | TRANSISTOR 2SC2785-HFE |
| Q212 | 8-729-119-78 | TRANSISTOR 2SC2785-HFE |
| Q213 | 8-729-119-78 | TRANSISTOR 2SC2785-HFE |
| Q214 | 8-729-119-78 | TRANSISTOR 2SC2785-HFE |
| Q215 | 8-729-119-78 | TRANSISTOR 2SC2785-HFE |
| Q217 | 8-729-119-78 | TRANSISTOR 2SC2785-HFE |
| Q218 | 8-729-119-78 | TRANSISTOR 2SC2785-HFE |
| Q219 | 8-729-806-28 | TRANSISTOR 2SC3402 |
| Q501 | 8-729-806-10 | TRANSISTOR 2SA1348 |
| Q502 | 8-729-806-10 | TRANSISTOR 2SA1348 |
| Q503 | 8-729-806-10 | TRANSISTOR 2SA1348 |
| Q504 | 8-729-806-10 | TRANSISTOR 2SA1348 |
| Q505 | 8-729-119-76 | TRANSISTOR 2SA1175-HFE |
| Q506 | 8-729-900-74 | TRANSISTOR DTC143TS |
| Q507 | 8-729-119-78 | TRANSISTOR 2SC2785-HFE |
| Q508 | 8-729-920-91 | TRANSISTOR 2SB1187-F |
| Q509 | 8-729-920-91 | TRANSISTOR 2SB1187-F |
| Q510 | 8-729-808-76 | TRANSISTOR 2SD1761-E |
| Q511 | 8-729-802-22 | TRANSISTOR 2SB1014 |
| Q512 | 8-729-802-22 | TRANSISTOR 2SB1014 |
| Q513 | 8-729-806-20 | TRANSISTOR 2SA1345 |
| Q514 | 8-729-806-20 | TRANSISTOR 2SA1345 |
| Q515 | 8-729-806-10 | TRANSISTOR 2SA1348 |
| Q516 | 8-729-806-28 | TRANSISTOR 2SC3402 |
| Q517 | 8-729-119-76 | TRANSISTOR 2SA1175-HFE |
| Q518 | 8-729-806-28 | TRANSISTOR 2SC3402 |
| Q801 | 8-729-806-10 | TRANSISTOR 2SA1348 |
| Q802 | 8-729-806-10 | TRANSISTOR 2SA1348 |
| Q803 | 8-729-806-10 | TRANSISTOR 2SA1348 |
| Q804 | 8-729-806-10 | TRANSISTOR 2SA1348 |
| Q805 | 8-729-806-10 | TRANSISTOR 2SA1348 |
| Q806 | 8-729-806-10 | TRANSISTOR 2SA1348 |
| Q807 | 8-729-806-10 | TRANSISTOR 2SA1348 |
| Q808 | 8-729-806-10 | TRANSISTOR 2SA1348 |
| Q809 | 8-729-806-10 | TRANSISTOR 2SA1348 |
| Q810 | 8-729-119-76 | TRANSISTOR 2SA1175-HFE |
| Q811 | 8-729-806-10 | TRANSISTOR 2SA1348 |
| Q812 | 8-729-806-28 | TRANSISTOR 2SC3402 |
| Q813 | 8-729-806-10 | TRANSISTOR 2SA1348 |
| Q814 | 8-729-119-76 | TRANSISTOR 2SA1175-HFE |
| Q815 | 8-729-119-76 | TRANSISTOR 2SA1175-HFE |
| Q816 | 8-729-119-76 | TRANSISTOR 2SA1175-HFE |
| Q817 | 8-729-119-76 | TRANSISTOR 2SA1175-HFE |
| Q818 | 8-729-119-76 | TRANSISTOR 2SA1175-HFE |
| Q819 | 8-729-119-76 | TRANSISTOR 2SA1175-HFE |
| Q820 | 8-729-119-76 | TRANSISTOR 2SA1175-HFE |
| Q822 | 8-729-806-10 | TRANSISTOR 2SA1348 |
| Q823 | 8-729-806-10 | TRANSISTOR 2SA1348 |

Note: The components identified by mark **△** or dotted line with mark **△** are critical for safety. Replace only with part number specified.

| Ref.No | Part No. | Description | | | |
|-----------------|----------------|------------------------|------|----|------|
| Q824 | 8-729-806-10 | TRANSISTOR 2SA1348 | | | |
| Q825 | 8-729-802-22 | TRANSISTOR 2SB1014 | | | |
| Q826 | 8-729-806-10 | TRANSISTOR 2SA1348 | | | |
| Q827 | 8-729-901-93 | TRANSISTOR 2SD1387 | | | |
| Q828 | 8-729-806-10 | TRANSISTOR 2SA1348 | | | |
| Q829 | 8-729-901-93 | TRANSISTOR 2SD1387 | | | |
| Q830 | 8-729-802-22 | TRANSISTOR 2SB1014 | | | |
| Q831 | 8-729-119-76 | TRANSISTOR 2SA1175-HFE | | | |
| Q832 | 8-729-802-22 | TRANSISTOR 2SB1014 | | | |
| Q833 | 8-729-806-10 | TRANSISTOR 2SA1348 | | | |
| RESISTOR | | | | | |
| R11B | 1-247-834-11 | CARBON | 1.3K | 5% | 1/4W |
| R12B | 1-249-414-11 | CARBON | 560 | 5% | 1/4W |
| R13B | 1-247-818-11 | CARBON | 300 | 5% | 1/4W |
| R14A | 1-249-408-11 | CARBON | 180 | 5% | 1/4W |
| R14B | 1-249-408-11 | CARBON | 180 | 5% | 1/4W |
| R16A | 1-249-410-11 | CARBON | 270 | 5% | 1/4W |
| R16B | 1-249-410-11 | CARBON | 270 | 5% | 1/4W |
| R17A | 1-249-437-11 | CARBON | 47K | 5% | 1/4W |
| R17B | 1-249-437-11 | CARBON | 47K | 5% | 1/4W |
| R18A | 1-249-437-11 | CARBON | 47K | 5% | 1/4W |
| R18B | 1-249-437-11 | CARBON | 47K | 5% | 1/4W |
| R21 | 1-249-425-11 | CARBON | 4.7K | 5% | 1/4W |
| R22 | 1-249-421-11 | CARBON | 2.2K | 5% | 1/4W |
| R23 | 1-249-421-11 | CARBON | 2.2K | 5% | 1/4W |
| R24 | 1-249-423-11 | CARBON | 3.3K | 5% | 1/4W |
| R25 | 1-249-429-11 | CARBON | 10K | 5% | 1/4W |
| R26 | 1-249-432-11 | CARBON | 18K | 5% | 1/4W |
| R27 | 1-249-426-11 | CARBON | 5.6K | 5% | 1/4W |
| R28 | 1-249-426-11 | CARBON | 5.6K | 5% | 1/4W |
| R29 | 1-249-425-11 | CARBON | 4.7K | 5% | 1/4W |
| R41A | 1-247-881-00 | CARBON | 120K | 5% | 1/4W |
| R41B | 1-249-435-11 | CARBON | 33K | 5% | 1/4W |
| R42A | 1-249-405-11 | CARBON | 100 | 5% | 1/4W |
| R42B | 1-249-404-00 | CARBON | 82 | 5% | 1/4W |
| R43A | 1-247-882-11 | CARBON | 130K | 5% | 1/4W |
| R43B | 1-247-882-11 | CARBON | 130K | 5% | 1/4W |
| R44A | 1-249-426-11 | CARBON | 5.6K | 5% | 1/4W |
| R44B | 1-249-426-11 | CARBON | 5.6K | 5% | 1/4W |
| R45 | 1-249-428-11 | CARBON | 8.2K | 5% | 1/4W |
| R51 | 1-249-435-11 | CARBON | 33K | 5% | 1/4W |
| R52 | 1-249-393-11 | CARBON | 10 | 5% | 1/4W |
| R53 | 1-247-883-00 | CARBON | 150K | 5% | 1/4W |
| R54 | 1-249-430-11 | CARBON | 12K | 5% | 1/4W |
| R61A | 1-247-881-00 | CARBON | 120K | 5% | 1/4W |
| R61B | 1-249-435-11 | CARBON | 33K | 5% | 1/4W |
| R62A | 1-249-405-11 | CARBON | 100 | 5% | 1/4W |
| R62B | 1-249-404-00 | CARBON | 82 | 5% | 1/4W |
| R63A | 1-247-882-11 | CARBON | 130K | 5% | 1/4W |
| R63B | 1-247-882-11 | CARBON | 130K | 5% | 1/4W |
| R64A | 1-249-426-11 | CARBON | 5.6K | 5% | 1/4W |
| R64B | 1-249-426-11 | CARBON | 5.6K | 5% | 1/4W |
| R65 | 1-249-428-11 | CARBON | 8.2K | 5% | 1/4W |
| R71 | 1-249-435-11 | CARBON | 33K | 5% | 1/4W |
| R72 | 1-249-393-11 | CARBON | 10 | 5% | 1/4W |
| R73 | 1-247-883-00 | CARBON | 150K | 5% | 1/4W |
| R74 | 1-249-430-11 | CARBON | 12K | 5% | 1/4W |
| R81A | 1-249-409-11 | CARBON | 220 | 5% | 1/4W |
| R81B | 1-249-409-11 | CARBON | 220 | 5% | 1/4W |
| R82A | 1-249-409-11 | CARBON | 220 | 5% | 1/4W |
| R82B | 1-249-409-11 | CARBON | 220 | 5% | 1/4W |
| R84B | △ 1-212-849-00 | FUSIBLE | 4.7 | 5% | 1/4W |
| R85B | 1-249-437-11 | CARBON | 47K | 5% | 1/4W |
| R86B | 1-249-437-11 | CARBON | 47K | 5% | 1/4W |
| R87B | 1-249-429-11 | CARBON | 10K | 5% | 1/4W |



| Ref.No | Part No. | Description | | | |
|--------|--------------|-------------|------|----|------|
| R88B | 1-249-429-11 | CARBON | 10K | 5% | 1/4W |
| R101 | 1-249-417-11 | CARBON | 1K | 5% | 1/4W |
| R102 | 1-249-436-11 | CARBON | 39K | 5% | 1/4W |
| R103 | 1-249-441-11 | CARBON | 100K | 5% | 1/4W |
| R104 | 1-249-433-11 | CARBON | 22K | 5% | 1/4W |
| R105 | 1-247-903-00 | CARBON | 1M | 5% | 1/4W |
| R106 | 1-249-433-11 | CARBON | 22K | 5% | 1/4W |
| R107 | 1-249-429-11 | CARBON | 10K | 5% | 1/4W |
| R108 | 1-249-433-11 | CARBON | 22K | 5% | 1/4W |
| R109 | 1-249-436-11 | CARBON | 39K | 5% | 1/4W |
| R110 | 1-249-440-11 | CARBON | 82K | 5% | 1/4W |
| R111 | 1-247-884-11 | CARBON | 160K | 5% | 1/4W |
| R112 | 1-249-423-11 | CARBON | 3.3K | 5% | 1/4W |
| R113 | 1-249-436-11 | CARBON | 39K | 5% | 1/4W |
| R114 | 1-249-417-11 | CARBON | 1K | 5% | 1/4W |
| R115 | 1-249-427-11 | CARBON | 6.8K | 5% | 1/4W |
| R116 | 1-247-887-00 | CARBON | 220K | 5% | 1/4W |
| R117 | 1-249-441-11 | CARBON | 100K | 5% | 1/4W |
| R119 | 1-249-433-11 | CARBON | 22K | 5% | 1/4W |
| R120 | 1-249-421-11 | CARBON | 2.2K | 5% | 1/4W |
| R122 | 1-249-440-11 | CARBON | 82K | 5% | 1/4W |
| R123 | 1-249-429-11 | CARBON | 10K | 5% | 1/4W |
| R124 | 1-249-437-11 | CARBON | 47K | 5% | 1/4W |
| R125 | 1-249-429-11 | CARBON | 10K | 5% | 1/4W |
| R126 | 1-249-397-11 | CARBON | 22 | 5% | 1/4W |
| R128 | 1-247-887-00 | CARBON | 220K | 5% | 1/4W |
| R129 | 1-249-424-11 | CARBON | 3.9K | 5% | 1/4W |
| R130 | 1-249-424-11 | CARBON | 3.9K | 5% | 1/4W |
| R131 | 1-249-427-11 | CARBON | 6.8K | 5% | 1/4W |
| R132 | 1-249-423-11 | CARBON | 3.3K | 5% | 1/4W |
| R133 | 1-247-822-11 | CARBON | 430 | 5% | 1/4W |
| R134 | 1-247-846-11 | CARBON | 4.3K | 5% | 1/4W |
| R135 | 1-247-840-00 | CARBON | 2.4K | 5% | 1/4W |
| R136 | 1-249-427-11 | CARBON | 6.8K | 5% | 1/4W |
| R137 | 1-249-415-11 | CARBON | 680 | 5% | 1/4W |
| R138 | 1-249-429-11 | CARBON | 10K | 5% | 1/4W |
| R139 | 1-249-429-11 | CARBON | 10K | 5% | 1/4W |
| R140 | 1-249-421-11 | CARBON | 2.2K | 5% | 1/4W |
| R141 | 1-249-441-11 | CARBON | 100K | 5% | 1/4W |
| R142 | 1-247-887-00 | CARBON | 220K | 5% | 1/4W |
| R143 | 1-249-421-11 | CARBON | 2.2K | 5% | 1/4W |
| R144 | 1-249-437-11 | CARBON | 47K | 5% | 1/4W |
| R145 | 1-249-437-11 | CARBON | 47K | 5% | 1/4W |
| R146 | 1-249-409-11 | CARBON | 220 | 5% | 1/4W |
| R148 | 1-247-848-11 | CARBON | 5.1K | 5% | 1/4W |
| R149 | 1-249-426-11 | CARBON | 5.6K | 5% | 1/4W |
| R150 | 1-249-424-11 | CARBON | 3.9K | 5% | 1/4W |
| R151 | 1-249-441-11 | CARBON | 100K | 5% | 1/4W |
| R152 | 1-249-407-11 | CARBON | 150 | 5% | 1/4W |
| R154 | 1-249-426-11 | CARBON | 5.6K | 5% | 1/4W |
| R156 | 1-249-423-11 | CARBON | 3.3K | 5% | 1/4W |
| R157 | 1-249-441-11 | CARBON | 100K | 5% | 1/4W |
| R158 | 1-249-421-11 | CARBON | 2.2K | 5% | 1/4W |
| R159 | 1-249-437-11 | CARBON | 47K | 5% | 1/4W |
| R160 | 1-249-437-11 | CARBON | 47K | 5% | 1/4W |
| R161 | 1-249-437-11 | CARBON | 47K | 5% | 1/4W |
| R162 | 1-249-425-11 | CARBON | 4.7K | 5% | 1/4W |
| R164 | 1-249-437-11 | CARBON | 47K | 5% | 1/4W |
| R165 | 1-249-437-11 | CARBON | 47K | 5% | 1/4W |
| R167 | 1-247-840-00 | CARBON | 2.4K | 5% | 1/4W |
| R168 | 1-247-887-00 | CARBON | 220K | 5% | 1/4W |
| R169 | 1-249-431-11 | CARBON | 15K | 5% | 1/4W |
| R170 | 1-249-433-11 | CARBON | 22K | 5% | 1/4W |
| R171 | 1-249-437-11 | CARBON | 47K | 5% | 1/4W |
| R201 | 1-249-417-11 | CARBON | 1K | 5% | 1/4W |

F

Note: The components identified by mark △ or dotted line with mark △ are critical for safety. Replace only with part number specified.

| Ref.No | Part No. | Description | | | | Ref.No | Part No. | Description | | | |
|--------|--------------|-------------|------|----|------|--------|--------------|-------------|------|----|------|
| R202 | 1-249-436-11 | CARBON | 39K | 5% | 1/4W | R507 | 1-249-429-11 | CARBON | 10K | 5% | 1/4W |
| R203 | 1-249-441-11 | CARBON | 100K | 5% | 1/4W | R509 | 1-249-425-11 | CARBON | 4.7K | 5% | 1/4W |
| R204 | 1-249-433-11 | CARBON | 22K | 5% | 1/4W | R510 | 1-249-441-11 | CARBON | 100K | 5% | 1/4W |
| R205 | 1-247-903-00 | CARBON | 1M | 5% | 1/4W | R511 | 1-249-429-11 | CARBON | 10K | 5% | 1/4W |
| R206 | 1-249-433-11 | CARBON | 22K | 5% | 1/4W | R512 | 1-249-411-11 | CARBON | 330 | 5% | 1/4W |
| R207 | 1-249-429-11 | CARBON | 10K | 5% | 1/4W | R513 | 1-247-844-11 | CARBON | 3.6K | 5% | 1/4W |
| R208 | 1-249-433-11 | CARBON | 22K | 5% | 1/4W | R514 | 1-249-429-11 | CARBON | 10K | 5% | 1/4W |
| R209 | 1-249-436-11 | CARBON | 39K | 5% | 1/4W | R515 | 1-249-421-11 | CARBON | 2.2K | 5% | 1/4W |
| R210 | 1-249-440-11 | CARBON | 82K | 5% | 1/4W | R552 | 1-249-425-11 | CARBON | 4.7K | 5% | 1/4W |
| R211 | 1-247-884-11 | CARBON | 160K | 5% | 1/4W | R554 | 1-247-887-00 | CARBON | 220K | 5% | 1/4W |
| R212 | 1-249-423-11 | CARBON | 3.3K | 5% | 1/4W | R555 | 1-249-429-11 | CARBON | 10K | 5% | 1/4W |
| R213 | 1-249-436-11 | CARBON | 39K | 5% | 1/4W | R556 | 1-249-441-11 | CARBON | 100K | 5% | 1/4W |
| R214 | 1-249-417-11 | CARBON | 1K | 5% | 1/4W | R557 | 1-249-428-11 | CARBON | 8.2K | 5% | 1/4W |
| R215 | 1-249-427-11 | CARBON | 6.8K | 5% | 1/4W | R558 | 1-249-423-11 | CARBON | 3.3K | 5% | 1/4W |
| R216 | 1-247-887-00 | CARBON | 220K | 5% | 1/4W | R559 | 1-249-441-11 | CARBON | 100K | 5% | 1/4W |
| R217 | 1-249-441-11 | CARBON | 100K | 5% | 1/4W | R560 | 1-249-417-11 | CARBON | 1K | 5% | 1/4W |
| R219 | 1-249-433-11 | CARBON | 22K | 5% | 1/4W | R561 | 1-249-441-11 | CARBON | 100K | 5% | 1/4W |
| R220 | 1-249-421-11 | CARBON | 2.2K | 5% | 1/4W | R562 | 1-249-429-11 | CARBON | 10K | 5% | 1/4W |
| R222 | 1-249-440-11 | CARBON | 82K | 5% | 1/4W | R563 | 1-249-441-11 | CARBON | 100K | 5% | 1/4W |
| R223 | 1-249-429-11 | CARBON | 10K | 5% | 1/4W | R564 | 1-249-417-11 | CARBON | 1K | 5% | 1/4W |
| R224 | 1-249-437-11 | CARBON | 47K | 5% | 1/4W | R565 | 1-249-437-11 | CARBON | 47K | 5% | 1/4W |
| R225 | 1-249-429-11 | CARBON | 10K | 5% | 1/4W | R567 | 1-249-420-11 | CARBON | 1.8K | 5% | 1/4W |
| R226 | 1-249-397-11 | CARBON | 22 | 5% | 1/4W | R568 | 1-249-427-11 | CARBON | 6.8K | 5% | 1/4W |
| R228 | 1-247-887-00 | CARBON | 220K | 5% | 1/4W | R569 | 1-249-427-11 | CARBON | 6.8K | 5% | 1/4W |
| R229 | 1-249-424-11 | CARBON | 3.9K | 5% | 1/4W | R570 | 1-247-854-11 | CARBON | 9.1K | 5% | 1/4W |
| R230 | 1-249-424-11 | CARBON | 3.9K | 5% | 1/4W | R571 | 1-249-419-11 | CARBON | 1.5K | 5% | 1/4W |
| R231 | 1-249-427-11 | CARBON | 6.8K | 5% | 1/4W | R572 | 1-249-417-11 | CARBON | 1K | 5% | 1/4W |
| R232 | 1-249-423-11 | CARBON | 3.3K | 5% | 1/4W | R573 | 1-249-419-11 | CARBON | 1.5K | 5% | 1/4W |
| R233 | 1-247-822-11 | CARBON | 430 | 5% | 1/4W | R574 | 1-249-427-11 | CARBON | 6.8K | 5% | 1/4W |
| R234 | 1-247-846-11 | CARBON | 4.3K | 5% | 1/4W | R575 | 1-249-420-11 | CARBON | 1.8K | 5% | 1/4W |
| R235 | 1-247-840-00 | CARBON | 2.4K | 5% | 1/4W | R576 | 1-249-429-11 | CARBON | 10K | 5% | 1/4W |
| R236 | 1-249-427-11 | CARBON | 6.8K | 5% | 1/4W | R577 | 1-247-850-11 | CARBON | 5.2K | 5% | 1/4W |
| R237 | 1-249-415-11 | CARBON | 680 | 5% | 1/4W | R578 | 1-249-417-11 | CARBON | 1K | 5% | 1/4W |
| R238 | 1-249-429-11 | CARBON | 10K | 5% | 1/4W | R579 | 1-249-433-11 | CARBON | 22K | 5% | 1/4W |
| R239 | 1-249-429-11 | CARBON | 10K | 5% | 1/4W | R581 | 1-249-417-11 | CARBON | 1K | 5% | 1/4W |
| R240 | 1-249-421-11 | CARBON | 2.2K | 5% | 1/4W | R582 | 1-249-425-11 | CARBON | 4.7K | 5% | 1/4W |
| R241 | 1-249-441-11 | CARBON | 100K | 5% | 1/4W | R583 | 1-249-425-11 | CARBON | 4.7K | 5% | 1/4W |
| R242 | 1-247-887-00 | CARBON | 220K | 5% | 1/4W | R584 | 1-249-425-11 | CARBON | 4.7K | 5% | 1/4W |
| R243 | 1-249-421-11 | CARBON | 2.2K | 5% | 1/4W | R585 | 1-249-421-11 | CARBON | 2.2K | 5% | 1/4W |
| R244 | 1-249-437-11 | CARBON | 47K | 5% | 1/4W | R586 | 1-249-425-11 | CARBON | 4.7K | 5% | 1/4W |
| R245 | 1-249-437-11 | CARBON | 47K | 5% | 1/4W | R587 | 1-247-887-00 | CARBON | 220K | 5% | 1/4W |
| R246 | 1-249-409-11 | CARBON | 220 | 5% | 1/4W | R588 | 1-249-439-11 | CARBON | 68K | 5% | 1/4W |
| R248 | 1-247-848-11 | CARBON | 5.1K | 5% | 1/4W | R589 | 1-249-417-11 | CARBON | 1K | 5% | 1/4W |
| R249 | 1-249-426-11 | CARBON | 5.6K | 5% | 1/4W | R591 | 1-249-409-11 | CARBON | 220 | 5% | 1/4W |
| R250 | 1-249-424-11 | CARBON | 3.9K | 5% | 1/4W | R801 | 1-249-429-11 | CARBON | 10K | 5% | 1/4W |
| R251 | 1-249-441-11 | CARBON | 100K | 5% | 1/4W | R802 | 1-249-427-11 | CARBON | 6.8K | 5% | 1/4W |
| R252 | 1-249-407-11 | CARBON | 150 | 5% | 1/4W | R803 | 1-249-422-11 | CARBON | 2.7K | 5% | 1/4W |
| R254 | 1-249-426-11 | CARBON | 5.6K | 5% | 1/4W | R804 | 1-249-430-11 | CARBON | 12K | 5% | 1/4W |
| R256 | 1-249-423-11 | CARBON | 3.3K | 5% | 1/4W | R805 | 1-249-437-11 | CARBON | 47K | 5% | 1/4W |
| R257 | 1-249-441-11 | CARBON | 100K | 5% | 1/4W | R806 | 1-249-437-11 | CARBON | 47K | 5% | 1/4W |
| R258 | 1-249-421-11 | CARBON | 2.2K | 5% | 1/4W | R807 | 1-249-425-11 | CARBON | 4.7K | 5% | 1/4W |
| R259 | 1-249-437-11 | CARBON | 47K | 5% | 1/4W | R808 | 1-249-417-11 | CARBON | 1K | 5% | 1/4W |
| R260 | 1-249-437-11 | CARBON | 47K | 5% | 1/4W | R809 | 1-249-416-11 | CARBON | 820 | 5% | 1/4W |
| R261 | 1-249-437-11 | CARBON | 47K | 5% | 1/4W | R810 | 1-249-419-11 | CARBON | 1.5K | 5% | 1/4W |
| R262 | 1-249-425-11 | CARBON | 4.7K | 5% | 1/4W | R811 | 1-249-422-11 | CARBON | 2.7K | 5% | 1/4W |
| R264 | 1-249-437-11 | CARBON | 47K | 5% | 1/4W | R812 | 1-249-427-11 | CARBON | 6.8K | 5% | 1/4W |
| R265 | 1-249-437-11 | CARBON | 47K | 5% | 1/4W | R828 | 1-249-424-11 | CARBON | 3.9K | 5% | 1/4W |
| R267 | 1-247-840-00 | CARBON | 2.4K | 5% | 1/4W | R829 | 1-249-430-11 | CARBON | 12K | 5% | 1/4W |
| R268 | 1-247-887-00 | CARBON | 220K | 5% | 1/4W | R830 | 1-249-426-11 | CARBON | 5.6K | 5% | 1/4W |
| R269 | 1-249-431-11 | CARBON | 15K | 5% | 1/4W | R831 | 1-249-430-11 | CARBON | 12K | 5% | 1/4W |
| R270 | 1-249-433-11 | CARBON | 22K | 5% | 1/4W | R832 | 1-249-412-11 | CARBON | 390 | 5% | 1/4W |
| R271 | 1-249-437-11 | CARBON | 47K | 5% | 1/4W | R833 | 1-249-411-11 | CARBON | 330 | 5% | 1/4W |
| R501 | 1-249-429-11 | CARBON | 10K | 5% | 1/4W | R834 | 1-249-413-11 | CARBON | 470 | 5% | 1/4W |
| R502 | 1-249-429-11 | CARBON | 10K | 5% | 1/4W | R835 | 1-249-415-11 | CARBON | 680 | 5% | 1/4W |
| R504 | 1-215-469-00 | METAL | 100K | 1% | 1/6W | R836 | 1-249-427-11 | CARBON | 6.8K | 5% | 1/4W |

| Ref.No | Part No. | Description | | | | |
|--------|----------------|---|------|----|------|--|
| R837 | 1-249-430-11 | CARBON | 12K | 5% | 1/4W | |
| R838 | 1-249-421-11 | CARBON | 2.2K | 5% | 1/4W | |
| R839 | 1-249-421-11 | CARBON | 2.2K | 5% | 1/4W | |
| R840 | 1-249-417-11 | CARBON | 1K | 5% | 1/4W | |
| R841 | 1-249-415-11 | CARBON | 680 | 5% | 1/4W | |
| R842 | 1-249-407-11 | CARBON | 150 | 5% | 1/4W | |
| R843 | 1-249-409-11 | CARBON | 220 | 5% | 1/4W | |
| R844 | 1-249-411-11 | CARBON | 330 | 5% | 1/4W | |
| R845 | 1-249-421-11 | CARBON | 2.2K | 5% | 1/4W | |
| R846 | 1-249-417-11 | CARBON | 1K | 5% | 1/4W | |
| R847 | 1-249-420-11 | CARBON | 1.8K | 5% | 1/4W | |
| R848 | 1-247-832-11 | CARBON | 1.1K | 5% | 1/4W | |
| R849 | 1-249-407-11 | CARBON | 150 | 5% | 1/4W | |
| R850 | 1-249-409-11 | CARBON | 220 | 5% | 1/4W | |
| R851 | 1-249-411-11 | CARBON | 330 | 5% | 1/4W | |
| R852 | 1-249-413-11 | CARBON | 470 | 5% | 1/4W | |
| R853 | 1-249-429-11 | CARBON | 10K | 5% | 1/4W | |
| R854 | 1-249-429-11 | CARBON | 10K | 5% | 1/4W | |
| R855 | 1-249-429-11 | CARBON | 10K | 5% | 1/4W | |
| R856 | 1-249-393-11 | CARBON | 10 | 5% | 1/4W | |
| R857 | 1-249-442-11 | CARBON | 510 | 5% | 1/4W | |
| R858 | 1-249-413-11 | CARBON | 470 | 5% | 1/4W | |
| R859 | 1-249-407-11 | CARBON | 150 | 5% | 1/4W | |
| R860 | 1-249-407-11 | CARBON | 150 | 5% | 1/4W | |
| R861 | 1-249-407-11 | CARBON | 150 | 5% | 1/4W | |
| R862 | 1-249-407-11 | CARBON | 150 | 5% | 1/4W | |
| R863 | 1-249-407-11 | CARBON | 150 | 5% | 1/4W | |
| R864 | 1-249-407-11 | CARBON | 150 | 5% | 1/4W | |
| R865 | 1-249-407-11 | CARBON | 150 | 5% | 1/4W | |
| R866 | 1-249-417-11 | CARBON | 1K | 5% | 1/4W | |
| R867 | 1-249-413-11 | CARBON | 470 | 5% | 1/4W | |
| R868 | 1-249-425-11 | CARBON | 4.7K | 5% | 1/4W | |
| R869 | 1-249-442-11 | CARBON | 510 | 5% | 1/4W | |
| R870 | 1-249-442-11 | CARBON | 510 | 5% | 1/4W | |
| R871 | 1-249-442-11 | CARBON | 510 | 5% | 1/4W | |
| R872 | 1-249-413-11 | CARBON | 470 | 5% | 1/4W | |
| R873 | 1-249-425-11 | CARBON | 4.7K | 5% | 1/4W | |
| R874 | 1-249-425-11 | CARBON | 4.7K | 5% | 1/4W | |
| R875 | 1-249-429-11 | CARBON | 10K | 5% | 1/4W | |
| R876 | 1-249-425-11 | CARBON | 4.7K | 5% | 1/4W | |
| R877 | 1-247-895-00 | CARBON | 470K | 5% | 1/4W | |
| R878 | 1-249-436-11 | CARBON | 39K | 5% | 1/4W | |
| R879 | 1-249-388-11 | CARBON | 3.9 | 5% | 1/4W | |
| R880 | 1-249-421-11 | CARBON | 2.2K | 5% | 1/4W | |
| R881 | 1-249-433-11 | CARBON | 22K | 5% | 1/4W | |
| R882 | 1-249-417-11 | CARBON | 1K | 5% | 1/4W | |
| R883 | 1-249-417-11 | CARBON | 1K | 5% | 1/4W | |
| R884 | 1-249-433-11 | CARBON | 22K | 5% | 1/4W | |
| R885 | 1-249-421-11 | CARBON | 2.2K | 5% | 1/4W | |
| R886 | 1-249-388-11 | CARBON | 3.9 | 5% | 1/4W | |
| R887 | 1-249-433-11 | CARBON | 22K | 5% | 1/4W | |
| R888 | 1-249-417-11 | CARBON | 1K | 5% | 1/4W | |
| R889 | 1-249-425-11 | CARBON | 4.7K | 5% | 1/4W | |
| R890 | 1-247-895-00 | CARBON | 470K | 5% | 1/4W | |
| R891 | 1-249-436-11 | CARBON | 39K | 5% | 1/4W | |
| R896 | 1-249-436-11 | CARBON | 39K | 5% | 1/4W | |
| R897 | 1-249-433-11 | CARBON | 22K | 5% | 1/4W | |
| R898 | 1-247-895-00 | CARBON | 470K | 5% | 1/4W | |
| R899 | 1-247-895-00 | CARBON | 470K | 5% | 1/4W | |
| R900 | 1-249-436-11 | CARBON | 39K | 5% | 1/4W | |
| R901 | 1-249-433-11 | CARBON | 22K | 5% | 1/4W | |
| R902 | 1-247-903-00 | CARBON | 1M | 5% | 1/4W | |
| R903 | 1-249-425-11 | CARBON | 4.7K | 5% | 1/4W | |
| R904 | 1-247-903-00 | CARBON | 1M | 5% | 1/4W | |
| R905 | 1-249-425-11 | CARBON | 4.7K | 5% | 1/4W | |
| R906 | 1-249-425-11 | CARBON | 4.7K | 5% | 1/4W | |
| RV41A | 1-228-989-00 | RES, ADJ, CARBON 470 | | | | |
| RV41B | 1-228-990-00 | RES, ADJ, CARBON 1K | | | | |
| RV42 | 1-230-497-11 | RES, ADJ, CARBON 22K | | | | |
| RV61A | 1-228-989-00 | RES, ADJ, CARBON 470 | | | | |
| RV61B | 1-228-990-00 | RES, ADJ, CARBON 1K | | | | |
| RV62 | 1-230-497-11 | RES, ADJ, CARBON 22K | | | | |
| RV102 | 1-228-994-00 | RES, ADJ, CARBON 10K | | | | |
| RV202 | 1-228-994-00 | RES, ADJ, CARBON 10K | | | | |
| RV501 | 1-238-300-11 | RES, VAR, CARBON 10K/10K (REC LEVEL) | | | | |
| RY81B | 1-515-614-11 | RELAY | | | | |
| S11A | 1-571-281-21 | SWITCH, LEAF (HALF DET) | | | | |
| S11B | 1-571-281-21 | SWITCH, LEAF (HALF DET) | | | | |
| S12B | 1-571-281-21 | SWITCH, LEAF (ERASE PROOF : SIDE A) | | | | |
| S13B | 1-571-281-21 | SWITCH, LEAF (ERASE PROOF : SIDE B) | | | | |
| S14A | 1-571-281-21 | SWITCH, LEAF (CrO2) | | | | |
| S14B | 1-571-281-21 | SWITCH, LEAF (CrO2) | | | | |
| S15B | 1-571-281-21 | SWITCH, LEAF (METAL) | | | | |
| S501 | 1-571-520-21 | SWITCH, SLIDE (DOLBY NR) | | | | |
| S502 | 1-571-520-21 | SWITCH, SLIDE (DIRECTION MODE) | | | | |
| S503 | 1-571-520-21 | SWITCH, SLIDE (MODE) | | | | |
| S504 | 1-570-103-21 | SWITCH, PUSH (1 KEY) (POWER) | | | | |
| S801 | 1-554-303-21 | SWITCH, KEY BOARD (AMS/BLANK SKIP) | | | | |
| S802 | 1-554-303-21 | SWITCH, KEY BOARD (HIGH SPEED) | | | | |
| S803 | 1-554-303-21 | SWITCH, KEY BOARD (NORM SPEED) | | | | |
| S804 | 1-554-303-21 | SWITCH, KEY BOARD (AUTO CD SYNCHRO) | | | | |
| S805 | 1-554-303-21 | SWITCH, KEY BOARD (AUTO PAUSE) | | | | |
| S806 | 1-554-303-21 | SWITCH, KEY BOARD (◀ (DECK A)) | | | | |
| S807 | 1-554-303-21 | SWITCH, KEY BOARD (▶ (DECK A)) | | | | |
| S808 | 1-554-303-21 | SWITCH, KEY BOARD (■ (DECK A)) | | | | |
| S809 | 1-554-303-21 | SWITCH, KEY BOARD (PAUSE (DECK A)) | | | | |
| S810 | 1-554-303-21 | SWITCH, KEY BOARD (▶ (DECK A)) | | | | |
| S811 | 1-554-303-21 | SWITCH, KEY BOARD (◀ (DECK A)) | | | | |
| S812 | 1-554-303-21 | SWITCH, KEY BOARD (◀ (DECK B)) | | | | |
| S813 | 1-554-303-21 | SWITCH, KEY BOARD (▶ (DECK B)) | | | | |
| S814 | 1-554-303-21 | SWITCH, KEY BOARD (REC (DECK B)) | | | | |
| S815 | 1-554-303-21 | SWITCH, KEY BOARD (■ (DECK B)) | | | | |
| S816 | 1-554-303-21 | SWITCH, KEY BOARD (PAUSE (DECK B)) | | | | |
| S817 | 1-554-303-21 | SWITCH, KEY BOARD (▶ (DECK B)) | | | | |
| S818 | 1-554-303-21 | SWITCH, KEY BOARD (◀ REC MUTE (DECK B)) | | | | |
| S819 | 1-554-303-21 | SWITCH, KEY BOARD (○ REC MUTE (DECK B)) | | | | |
| S820 | 1-554-303-21 | SWITCH, KEY BOARD (CCLA) | | | | |
| S821 | 1-554-303-21 | SWITCH, KEY BOARD (DECK A/B) | | | | |
| S822 | 1-554-303-21 | SWITCH, KEY BOARD (MEMORY) | | | | |
| S823 | 1-554-303-21 | SWITCH, KEY BOARD (RESET) | | | | |
| S901-B | 1-571-028-11 | (DECK B)...SWITCH, LEAF (REC SW) | | | | |
| SPK101 | 1-235-186-00 | ENCAPSULATED COMPONENT | | | | |
| SPK201 | 1-235-186-00 | ENCAPSULATED COMPONENT | | | | |
| T51 | 1-433-335-11 | TRANSFORMER, BIAS OSCILLATION | | | | |
| T71 | 1-433-335-11 | TRANSFORMER, BIAS OSCILLATION | | | | |
| T81B | 1-433-335-11 | TRANSFORMER, BIAS OSCILLATION | | | | |
| T901 | △ 1-449-460-11 | TRANSFORMER, POWER | | | | |
| TP1 | * 1-564-336-00 | PIN, CONNECTOR 2P | | | | |
| TP83B | * 1-564-338-00 | PIN, CONNECTOR 4P | | | | |
| TP91 | * 1-564-508-11 | PLUG, CONNECTOR 5P | | | | |
| X801 | 1-577-358-21 | VIBRATOR, CERAMIC 4MHz | | | | |
| X802 | 1-577-360-11 | VIBRATOR, CERAMIC 6MHz | | | | |

Note: The components identified by mark  or dotted line with mark  are critical for safety. Replace only with part number specified.