

TC-K370/RX370

SERVICE MANUAL

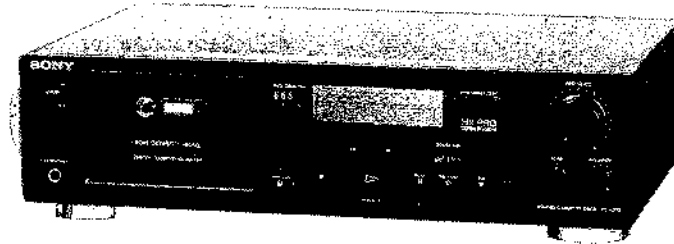



Photo: TC-K370

AEP Model
UK Model
Australian Model
 TC-K370
US Model
Canadian Model
AEP Model
 TC-RX370

* Dolby noise reduction and HX Pro headroom extension manufactured under license from Dolby Laboratories Licensing Corporation. HX Pro originated by Bang & Olufsen.

"DOLBY", the double-D symbol  and "HX PRO" are trademarks of Dolby Laboratories Licensing Corporation.

SPECIFICATIONS

Recording system 4-track 2-channel stereo
 Fast-winding time Approx. 90 sec. (with Sony C-60 cassette)
 Bias AC bias
 Motors Capstan motor x 1 (DC motor)
 Reel motor x 1 (DC motor)

Signal-to-noise ratio (at peak level)

Cassette	Dolby NR switch	OFF	B-Type ON	C-Type ON
	Type IV (Sony METAL-SLT)		58 dB	66 dB
Type II (Sony UX-S)		57 dB	65 dB	72 dB
Type I (Sony HF-S)		55 dB	63 dB	70 dB

Total harmonic distortion 1% (with Sony METAL-SLT cassette)

Frequency response (DOLBY NR OFF)

Type IV cassette (Sony METAL-SLT)	30 - 15,000 Hz (± 3 dB, IEC)
	30 - 13,000 Hz [± 3 dB, 0VU (-4 dB) recording]
Type II cassette (Sony UX-S)	30 - 15,000 Hz (± 3 dB, IEC)
Type I cassette (Sony HF-S)	30 - 14,000 Hz (± 3 dB, IEC)

Wow and flutter $\pm 0.13\%$ W. Peak (IEC)
 0.07% WRMS (NAB)
 $\pm 0.18\%$ W. Peak (DIN)

Inputs

Line inputs (phono jacks)	Sensitivity	77.5 mV
	Input impedance	47 k ohms

Model Name Using Similar Mechanism	TC-W370/W411 /WR511/WR570	
Tape Transport Mechanism Type	TC-K370	TCM-190VB12C
	TC-RX370	TCM-190RB12C

Outputs

Line outputs (phono jacks)	Rated output level	0.32 V at a load impedance of 47 k ohms
	Load impedance	Over 10 k ohms
Headphones (stereo phone jack)	Output level	0.3 mW at a load impedance of 32 ohms

General

Power requirements US, Canadian model: 120V AC, 60Hz
 AEP, Germany, Australian model: 220-230V AC, (or 240V AC adjustable by Sony personnel) 50/60Hz
 UK model: 240V AC, (or 220V AC adjustable by Sony personnel) 50/60Hz

Power consumption 20 W

Dimensions Approx. 430 x 123 x 287 mm (w/h/d)
 (17 x 4 $\frac{7}{8}$ x 11 $\frac{3}{8}$ inches)
 including projecting parts and controls

Weight Approx. 3.9 kg (8 lbs 10 oz)

Supplied accessory Audio connecting cords (2)

Design and specifications subject to change without notice.

STEREO CASSETTE DECK
SONY[®]

SAFETY CHECK-OUT

After correcting the original service problem, perform the following safety check before releasing the set to the customer:

Check the antenna terminals, metal trim, "metallized" knobs, screws, and all other exposed metal parts for AC leakage. Check leakage as described below.

LEAKAGE TEST

The AC leakage from any exposed metal part to earth ground and from all exposed metal parts to any exposed metal part having a return to chassis, must not exceed 0.5 mA (500 microamperes). Leakage current can be measured by any one of three methods.

1. A commercial leakage tester, such as the Simpson 229 or RCA WT-540A. Follow the manufacturers' instructions to use these instruments.
2. A battery-operated AC milliammeter. The Data Precision 245 digital multimeter is suitable for this job.
3. Measuring the voltage drop across a resistor by means of a VOM or battery-operated AC voltmeter. The "limit" indication is 0.75 V, so analog meters must have an accurate low-voltage scale. The Simpson 250 and Sanwa SH-63Trd are examples of a passive VOM that is suitable. Nearly all battery operated digital multimeters that have a 2 V AC range are suitable. (See Fig. A)

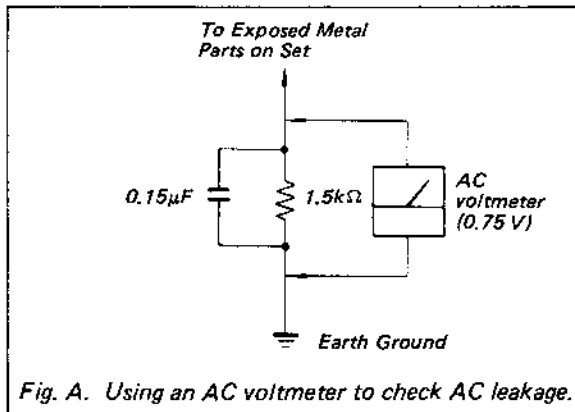

Fig. A. Using an AC voltmeter to check AC leakage.

SAFETY-RELATED COMPONENT WARNING!!



COMPONENTS IDENTIFIED BY MARK  OR DOTTED LINE WITH MARK  ON THE SCHEMATIC DIAGRAMS AND IN THE PARTS LIST ARE CRITICAL TO SAFE OPERATION. REPLACE THESE COMPONENTS WITH SONY PARTS WHOSE PART NUMBERS APPEAR AS SHOWN IN THIS MANUAL OR IN SUPPLEMENTS PUBLISHED BY SONY.

TABLE OF CONTENTS

<i>Section</i>	<i>Title</i>	<i>Page</i>
SECTION 1.	GENERAL · · · · ·	3
SECTION 2.	DISASSEMBLY · · · · ·	4
SECTION 3.	ADJUSTMENTS · · · · ·	6
SECTION 4.	DIAGRAMS	
4-1.	Circuit Boards Location · · · · ·	11
4-2.	Semiconductor Lead Layouts · · · · ·	11
4-3.	Printed Wiring Boards · · · · ·	12
4-4.	Schematic Diagram · · · · ·	16
SECTION 5.	EXPLODED VIEWS	
5-1.	Chassis Section · · · · ·	19
5-2.	Front Panel Section · · · · ·	20
5-3.	Mechanism Section-1 · · · · ·	21
5-4.	Mechanism Section-2 · · · · ·	22
SECTION 6.	ELECTRICAL PARTS LIST · · · · ·	23

MODEL IDENTIFICATION

(Specification Label)

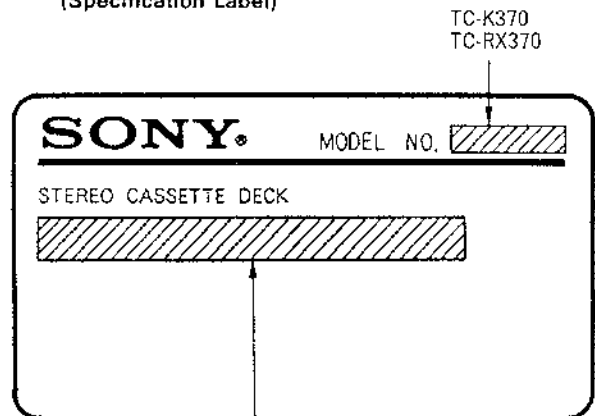

US, Canadian model: AC120V 60Hz 20W
 UK, Australian model: AC240V ~50/60Hz
 Germany, AEP model: AC220-230V ~50/60Hz

ATTENTION AU COMPOSANT AYANT RAPPORT À LA SÉCURITÉ!

LES COMPOSANTS IDENTIFIÉS PAR UNE MARQUE  SUR LES DIAGRAMMES SCHÉMATIQUES ET LA LISTE DES PIÈCES SONT CRITIQUES POUR LA SÉCURITÉ DE FONCTIONNEMENT. NE REMPLACER CES COMPOSANTS QUE PAR DES PIÈCES SONY DONT LES NUMÉROS SONT DONNÉS DANS CE MANUEL OU DANS LES SUPPLÉMENTS PUBLIÉS PAR SONY.

SECTION 1 GENERAL

Identification of Front Panel Parts

This section is extracted from instruction manual.

TC-K370

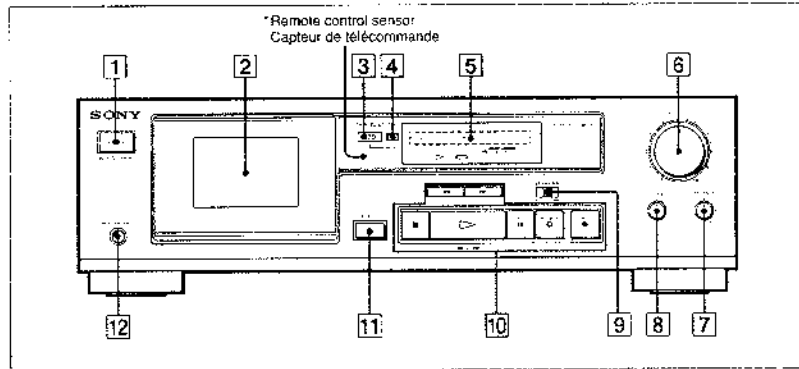

For details, refer to the page number indicated in ●

- 1 POWER switch
 - 2 Cassette holder
 - 3 TAPE COUNTER
 - 4 RESET button
 - 5 PEAK LEVEL METER ●
 - 6 REC (recording) LEVEL control ● ●
 - 7 BALANCE control ●
 - 8 BIAS control ●
 - 9 DOLBY NR (noise reduction switch) ● ●
 - 10 Tape operation buttons
 - ◀◀ (leftward fast winding) button
 - (stop) button
 - ▶▶ (play) button
 - ▶▶▶ (rightward fast winding) button
 - || PAUSE button
 - 11 EJECT button
 - 12 HEADPHONES jack (stereo phone jack) ●
- *Remote control sensor
Capteur de télécommande
- You can remotely control this cassette deck with:
 — A remote commander that came with a Sony amplifier or receiver if it has the mark and cassette deck control capability.
 — An optional Sony remote commander with the mark and cassette deck control capability.

TC-RX370

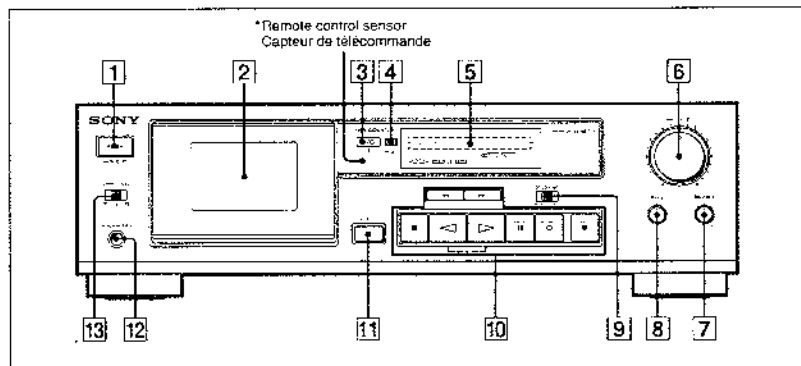

For details, refer to the page number indicated in ●

- 1 POWER switch
 - 2 Cassette holder
 - 3 TAPE COUNTER
 - 4 RESET button
 - 5 PEAK LEVEL METER ●
 - 6 REC (recording) LEVEL control ● ●
 - 7 BALANCE control ●
 - 8 BIAS control ●
 - 9 DOLBY NR (noise reduction) switch ● ●
 - 10 Tape operation buttons
 - ◀◀ (leftward fast winding) button
 - (stop) button
 - ◀ (reverse play) button
 - ▶ (play) button
 - ▶▶▶ (rightward fast winding) button
 - || PAUSE button
 - 11 EJECT button
 - 12 HEADPHONES jack (stereo phone jack) ●
 - 13 DIRECTION mode switch ● ●
- *Remote control sensor
Capteur de télécommande
- You can remotely control this cassette deck with:
 — A remote commander that came with a Sony amplifier or receiver if it has the mark and cassette deck control capability.
 — An optional Sony remote commander with the mark and cassette deck control capability.

SECTION 2 DISASSEMBLY

Note: Follow the disassembly procedure in the numerical order given.

CASE
Unscrew the four case attachment screws M3×8 and remove the case.

FRONT PANEL

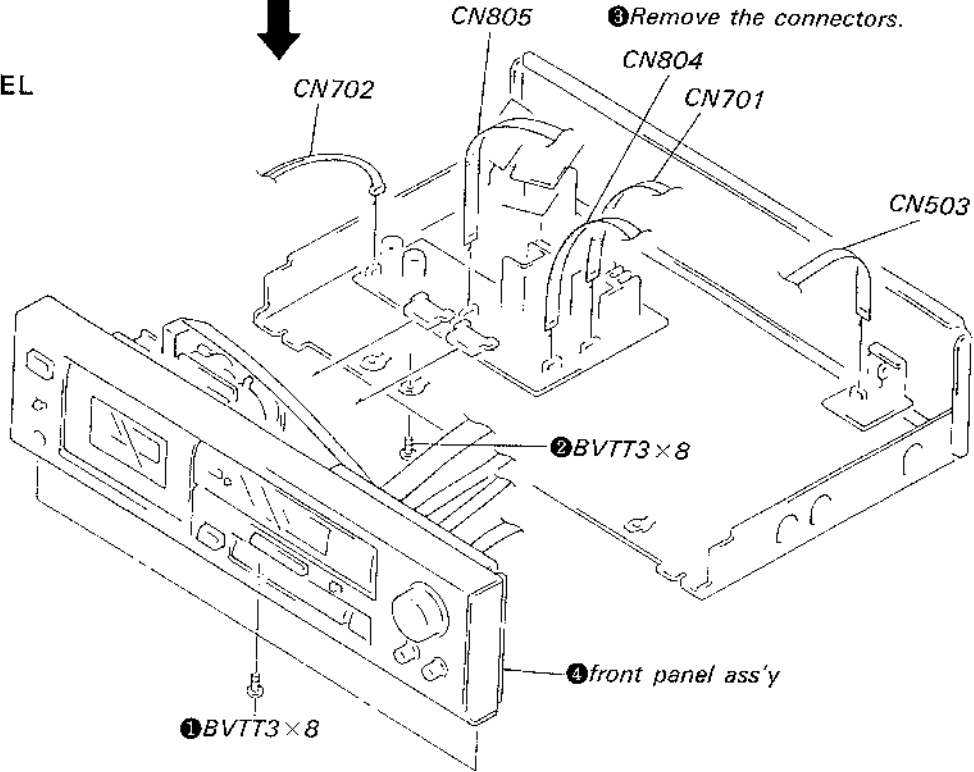

MECHANISM DECK

1 Press the eject button.

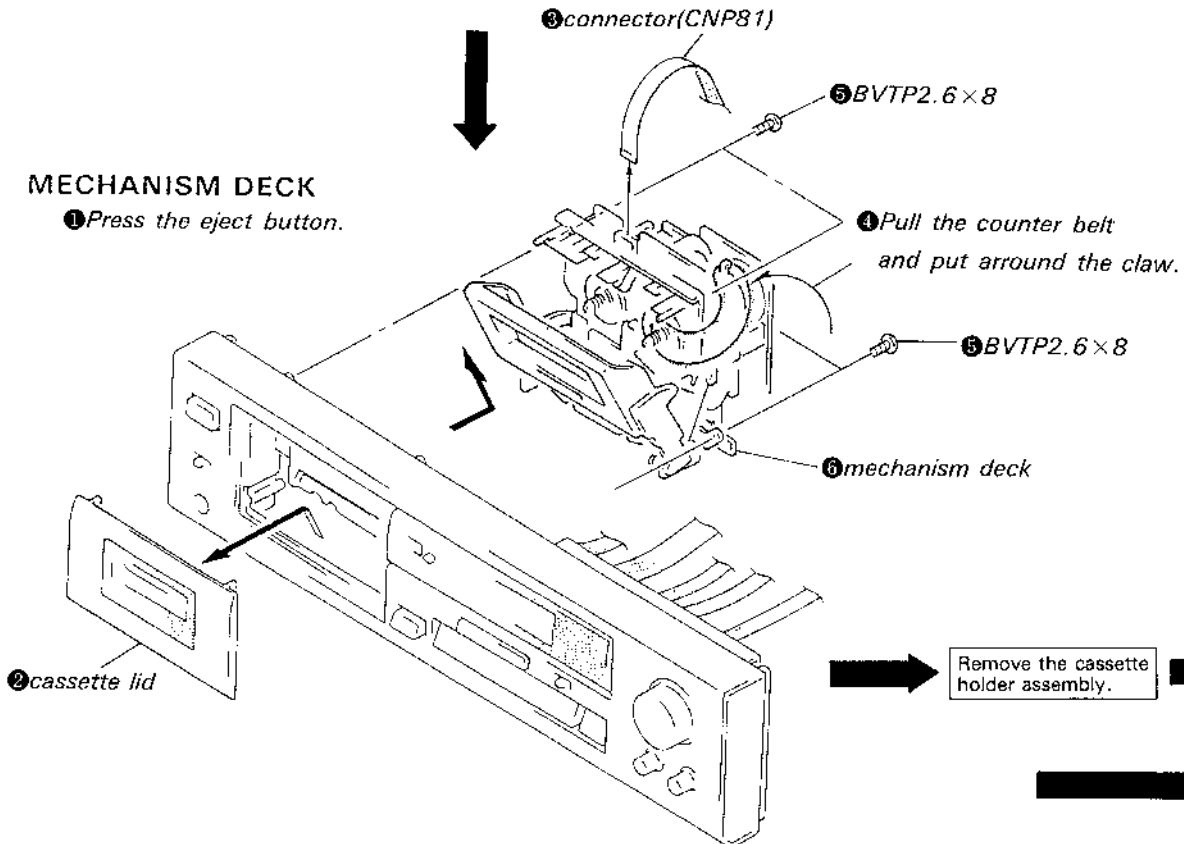

HEAD

(TC-K370)

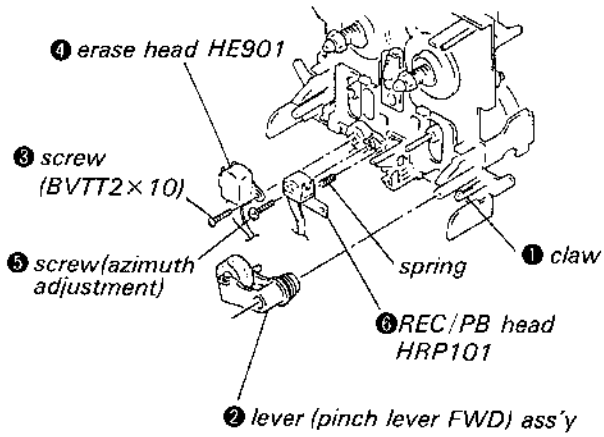

(TC-RX370)

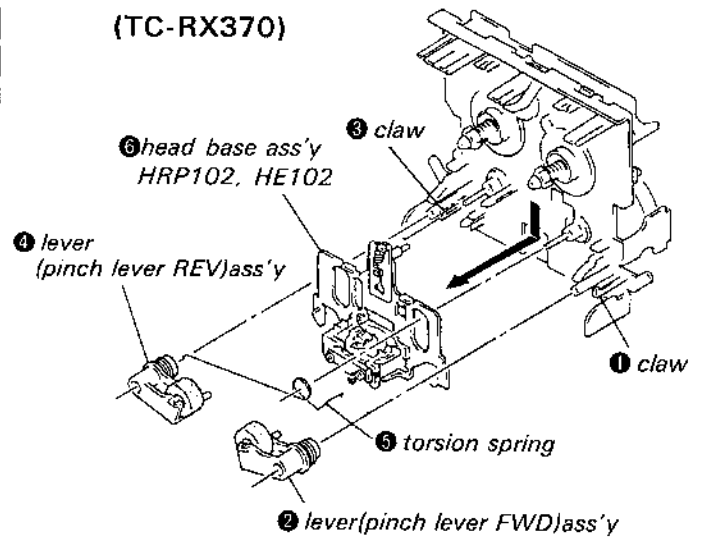

MOTOR

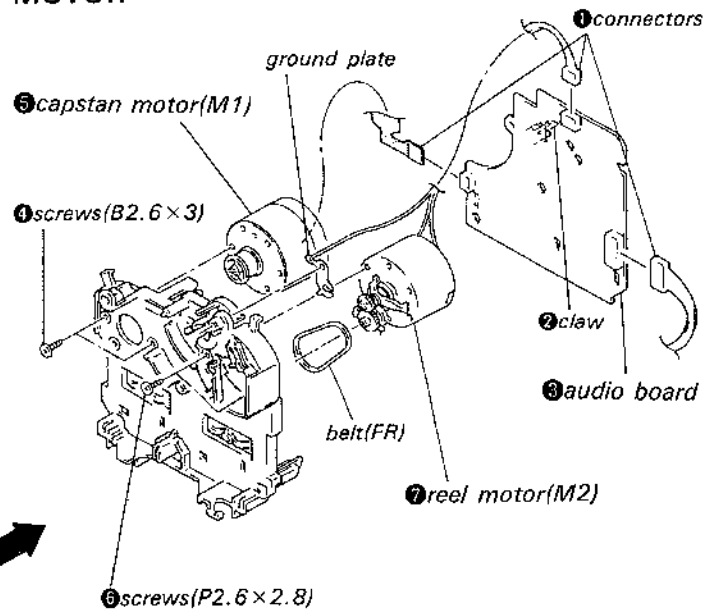

FITTING BASE BLOCK

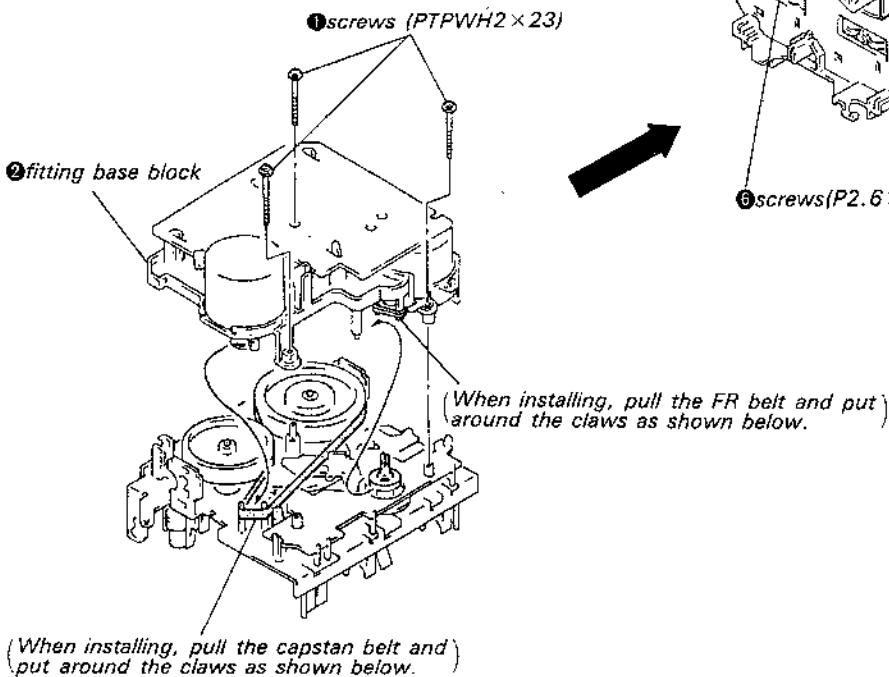

SECTION 3 ADJUSTMENTS

3-1. MECHANICAL ADJUSTMENTS

PRECAUTION

1. Clean the following parts with a denatured alcohol-moistened swab :

record/playback/erase head(TC-RX370)	pinch roller
record/playback(TC-K370) erase head(TC-K370)	rubber belts
capstan	idlers
2. Demagnetize the record/playback head with a head demagnetizer.
(Head demagnetizer do not approach for the erase head.)
3. Do not use a magnetized screwdriver for the adjustment.
4. After the adjustments, apply suitable locking compound to the parts adjusted.
5. The adjustments should be performed with the rated power supply voltage unless otherwise noted.

Torque Measurement

Torque	Torque meter	Meter reading
Forward	CQ-102C	30 to 65g · cm (0.42 to 0.9 oz · inch)
Forward back tension	CQ-102C	DECK A : 1 to 6g · cm (0.014 to 0.08 oz · inch) DECK B : 2 to 9g · cm (0.03 to 0.12 oz · inch)
Reverse (TC-RX370)	CQ-102RC	30 to 65g · cm (0.42 to 0.9 oz · inch)
Reverse back tension (TC-RX370)	CQ-102RC	1 to 6g · cm (0.014 to 0.08 oz · inch)
FF, REW	CQ-201B	70 to 120g · cm (0.98 to 1.67 oz · inch)

Standard Input Level

Input terminal	LINE IN
source impedance	10kΩ
input signal level	0.25V (-10dB)

Standard Output Level

Output terminal	LINE OUT
load impedance	47kΩ
output signal level	0.44V (-5dB)

Test Tape

Tape	Contents	Use
P-4-A100	10kHz, -10dB	Azimuth Adjustment
P-4-L300	315Hz, 0dB	PB Level Adjustment
WS-48B	3kHz, 0dB	Tape Speed Adjustment

0dB=0.775V

Record/Playback Head(TC-K370) Azimuth Adjustment Record/Playback/Erase Head(TC-RX370)

Procedure :

1. Forward Playback Mode

test tape
P-4-A100
(10kHz, -10dB)

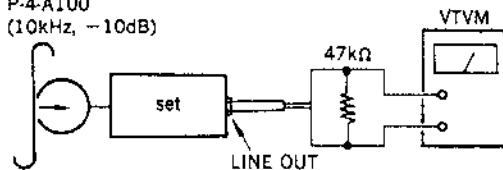

2. Turn the adjustment screw for the maximum output levels. If these levels do not match, turn the adjustment screw until both of output levels match together within 1dB.

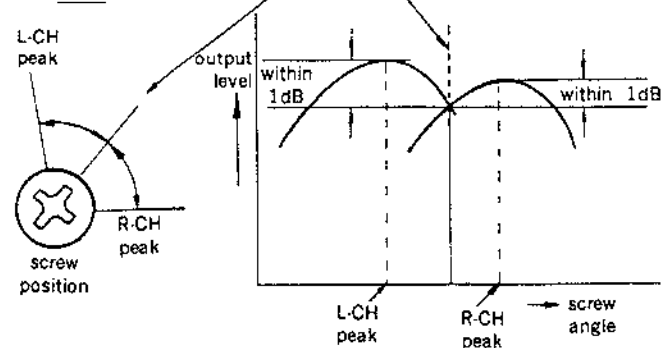

3-2. ELECTRICAL ADJUSTMENTS

PRECAUTION

1. The adjustment should be performed in the publication.
(Be sure to make playback adjustment at first.)
2. The adjustment and measurement should be performed for both L-CH and R-CH.
 - Switch position
DOLBY NR switch : OFF
DIR MODE switch : ⇄
 - Standard record position
Deliver the standard input signal level to input jack and set the REC LEVEL control to obtain the standard output signal level as follows.

—Record Mode—

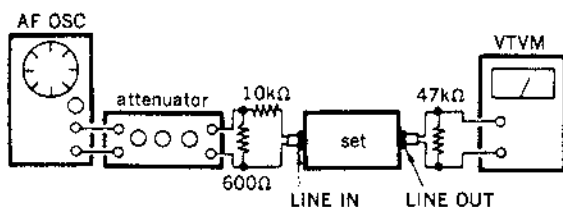

3. Phase check

Playback Mode

test tape
P-4-A100
(10kHz, -10dB)

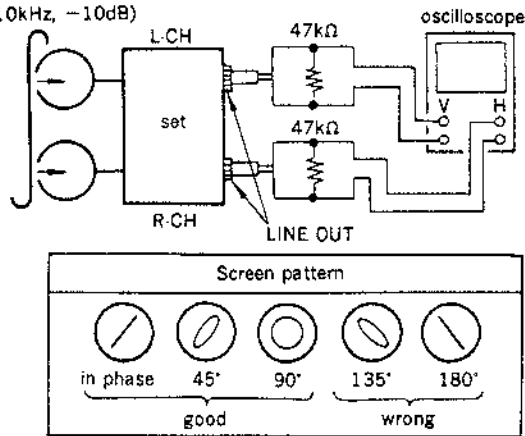

4. Change the reverse playback mode and repeat the steps 1 to 3. (TC-RX370)
5. After the adjustment, lock the adjustment screw with suitable locking compound.

Adjustment Location : — record/playback/erase head —

TC-K370

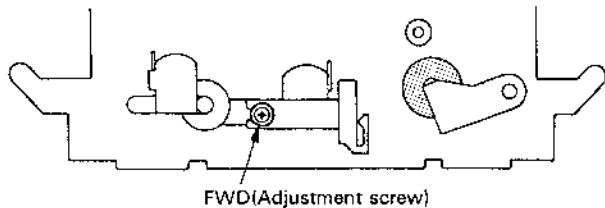

TC-RX370

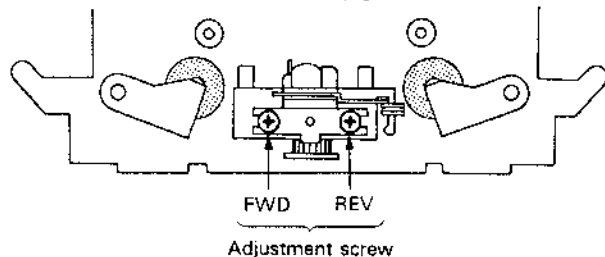

Tape Speed Adjustment

Procedure :

—Forward Playback Mode—

test tape
WS-48B
(3kHz, 0dB)

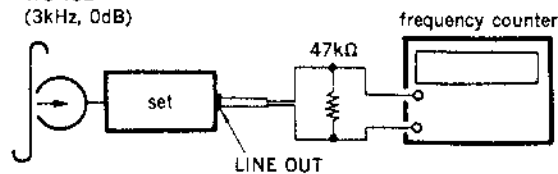

Perform high speed adjustment before normal speed adjustment.

(high speed adjustment)

1. Set to FWD playback mode.
2. Keep on pressing the HIGH SPEED DUBBING switch.
3. Adjust RV72 so that the frequency counter reading becomes $6,000 \pm 30\text{Hz}$.

(normal speed adjustment)

1. Set to FWD playback mode.
2. Adjust RV71 so that the frequency counter reading becomes $3,000 \pm 10\text{Hz}$.

Frequency difference between the beginning and the end of the tape should be within 3%.

Adjustment Location : AUDIO board

Playback Level Adjustment

Procedure :

—Forward Playback Mode—

test tape
P-4-L300
(315Hz, 0dB)

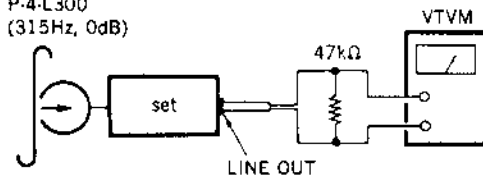

Adjust RV11 (L-CH) and RV21 (R-CH) so the VTVM reading becomes the adjustment limits below.

Adjustment Value :

LINE OUT level : $-5 \pm 0.5\text{dB}$ (0.412 to 0.461V)

Level Difference between Channels : within 0.5dB

Confirm the LINE OUT level does not change in playback mode while changing the mode from playback to stop several times.

Adjustment Location : AUDIO board

Bias Consumption Current Adjustment

This adjustment should be performed when replacing the head assy or the bias oscillating transformer (T81, T91).

Procedure :

() : R-CH

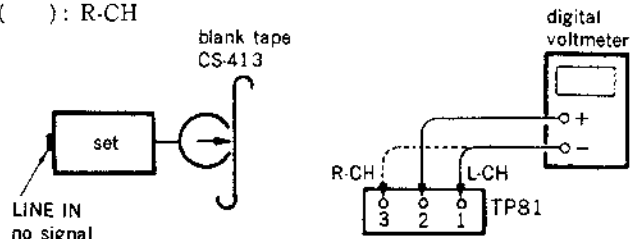

1. Connect the digital voltmeter to test point TP81.
2. Set RV81 (RV91) to mechanical center.
3. Set to FWD record mode.
4. Adjust T81 (T91) so that the digital voltmeter reading becomes minimum.

Adjustment Location : AUDIO board

Record Bias Adjustment

Setting :

REC LEVEL control : standard record position (Refer to page 6.)

Procedure :

1. Record Mode

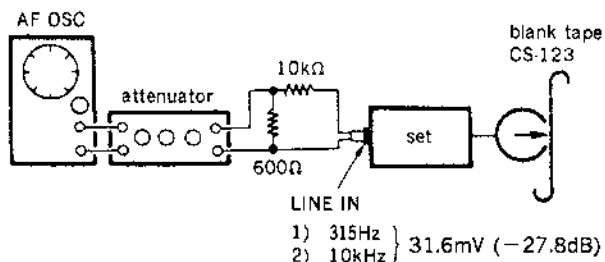

2. Playback Mode

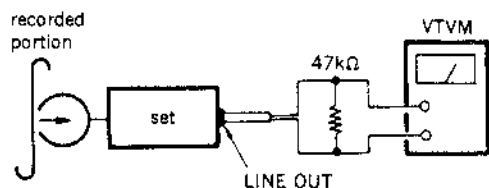

Playback the signal recorded in step 1.
Confirm that the 10kHz playback output is $0 \pm 0.5\text{dB}$ relative to the 315Hz output. If necessary, adjust RV81 (L-CH), RV91 (R-CH) and repeat the steps given above.

Adjustment Location : AUDIO board

Record Level Adjustment

Setting :

REC LEVEL control : standard record position (Refer to page 6.)

Procedure :

1. Record Mode

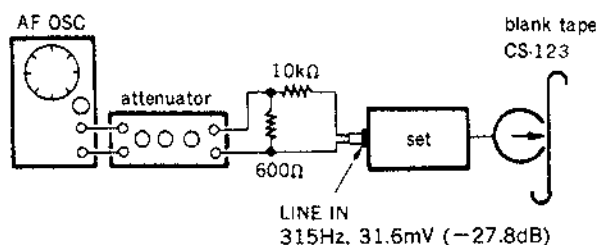

2. Playback Mode

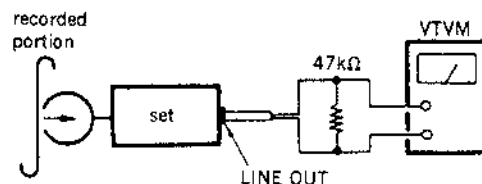

Confirm playback the tape recorded become adjustment level as follows.

If necessary, adjust RV101 (L-CH), RV201 (R-CH) and repeat steps 1 and 2.

Adjustment Value :

LINE OUT level : $-27.8 \pm 0.5\text{dB}$ (29 to 33.4mV)

Adjustment Location : PANEL Board

—Adjustment Parts Location Diagrams—

[PANEL BOARD] (COMPONENT SIDE)

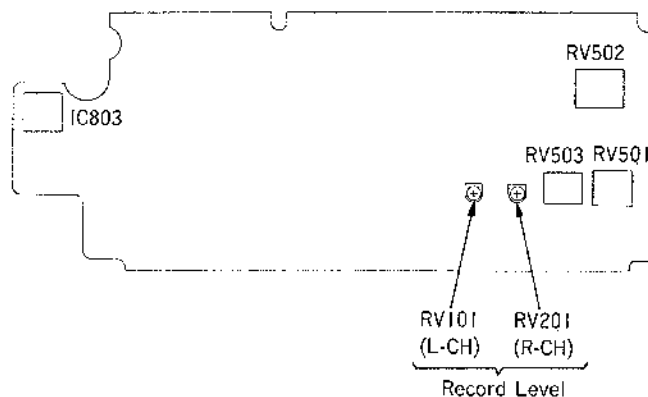

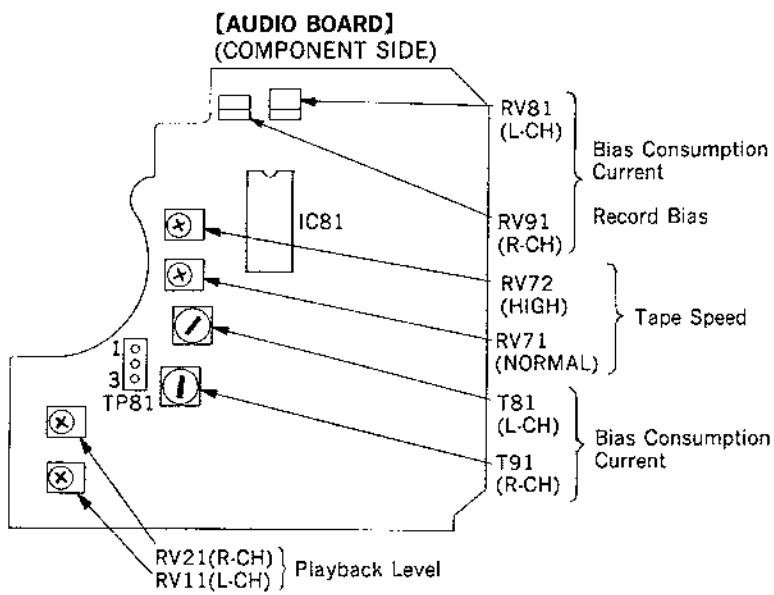

SECTION 4
DIAGRAMS

4-1. CIRCUIT BOARDS LOCATION

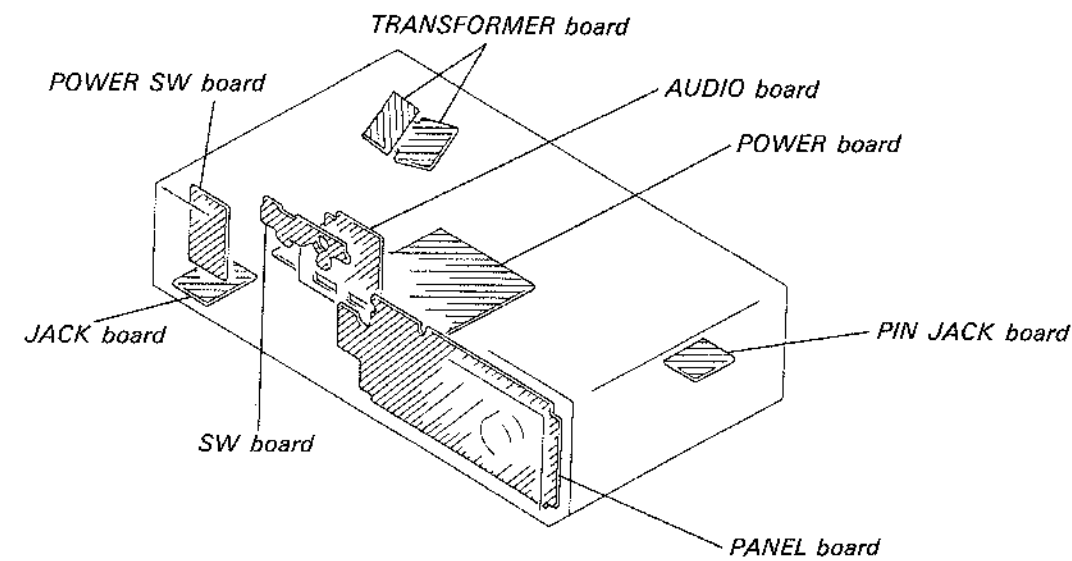

4-2. SEMICONDUCTOR LEAD LAYOUTS

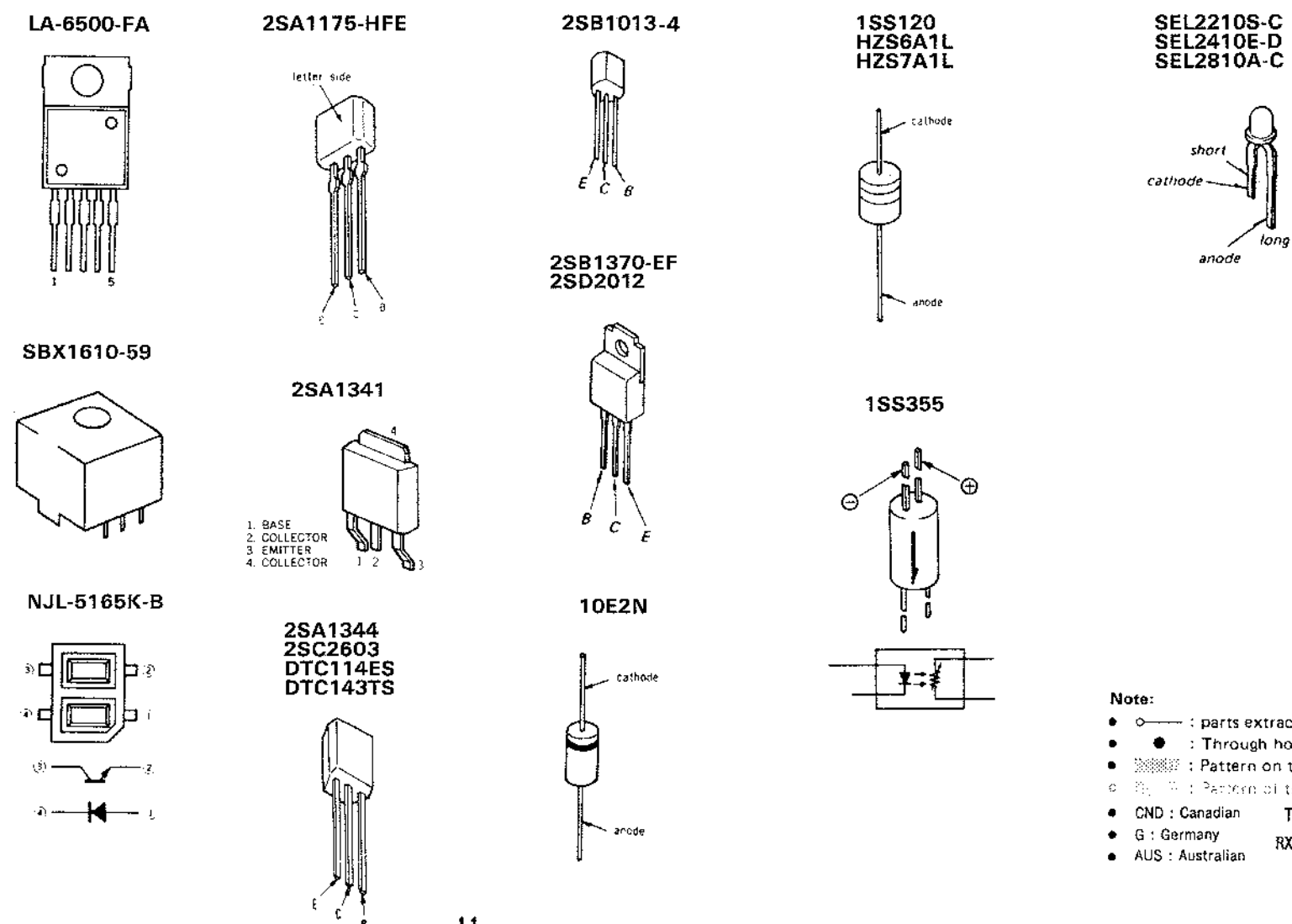

Note:
 ○ : parts extracted from the component side.
 ● : Through hole.
 ▨ : Pattern on the side which is seen.
 ◊ : Pattern of the rear side.
 ● GND : Canadian T370:TC-K370
 ● G : Germany RX370:TC-RX370
 ● AUS : Australian

● Semiconductor Location

Ref. No.	Location	Ref. No.	Location
D31	I-12	IC31	I-13
D101	B-5	IC81(AUDIO)	H-14
D102	B-5	IC81(SW)	D-15
D201	C-6	IC501	C-4
D501	D-5	IC502	D-4
D502	E-3	IC503	E-2
D701	H-5	IC504	C-5
D702	H-5	IC505	C-5
D703	H-5	IC506	D-5
D704	H-5	IC701	G-8
D705	H-5	IC801	C-7
D706	H-5	IC802	G-10
D707	F-5	IC803	C-10
D708	G-7		
D709	H-8	Q51	H-12
D710	G-6	Q52	H-13
D711	I-10	Q53	H-12
D801	F-10	Q71	H-14
D802	E-5	Q101	A-2
D810	B-9	Q102	B-4
D818	B-9	Q201	B-2
D819	C-8	Q202	B-3
D820	C-8	Q501	E-2
D821	C-9	Q701	I-8
D822	C-9	Q702	H-8
D823	C-9	Q703	G-6
D824	C-7	Q704	H-10
D825	C-7	Q705	I-10
D826	C-7	Q706	I-10
D827	C-8	Q707	H-10
D828	B-7	Q801	F-10
D829	B-7	Q802	F-10
D830	B-7	Q803	E-2
D831	B-7	Q804	F-7
D832	B-7	Q805	C-5
D833	B-7	Q806	B-5
D834	B-8	Q808	D-4
D835	B-8	Q809	C-10
D836	B-8	Q810	D-9
D837	B-8	Q811	D-10
D838	B-8	Q812	D-1
D839	B-8		
D849	B-9		
D850	B-9		

4-3. PRINTED WIRING BOARDS

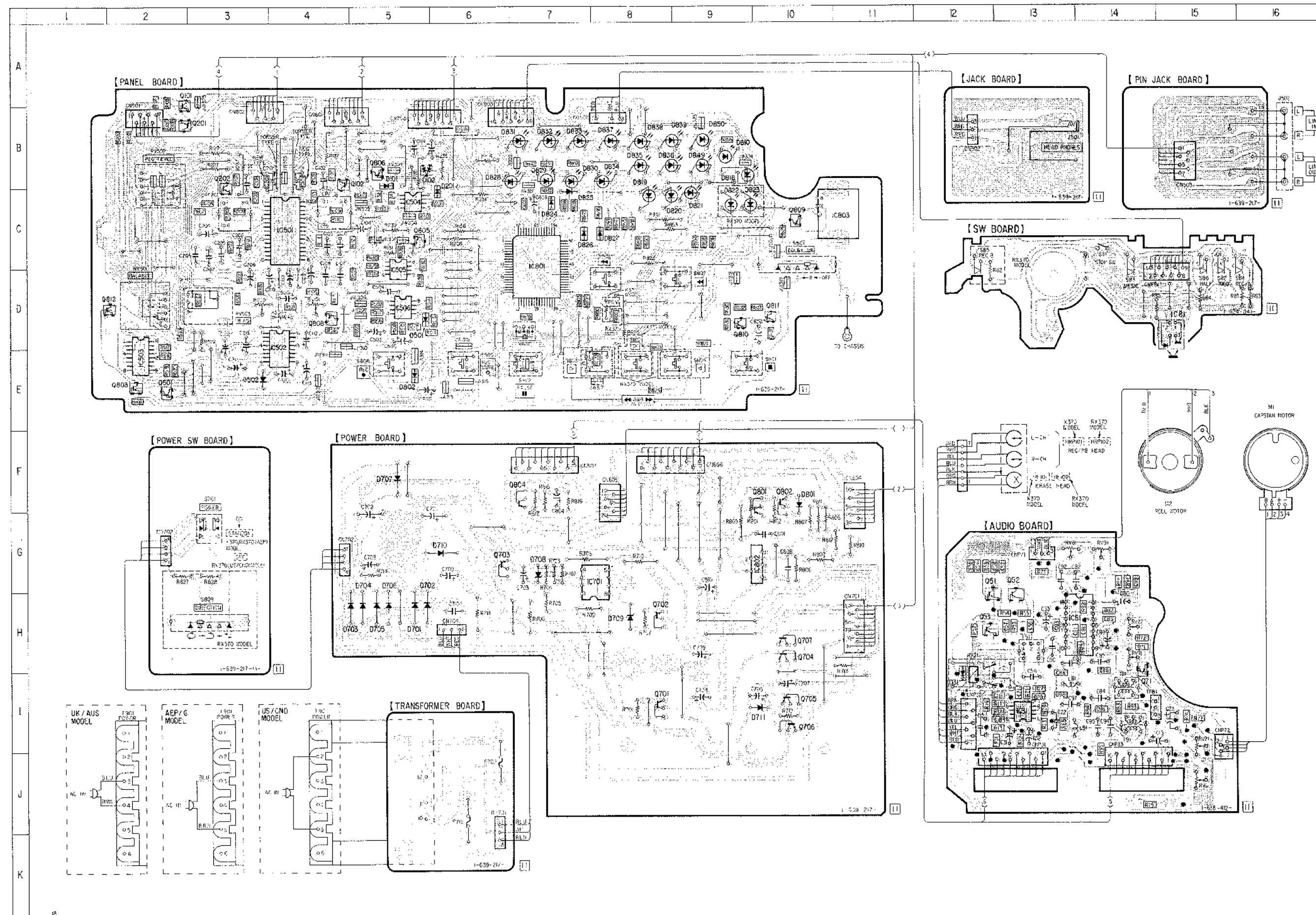

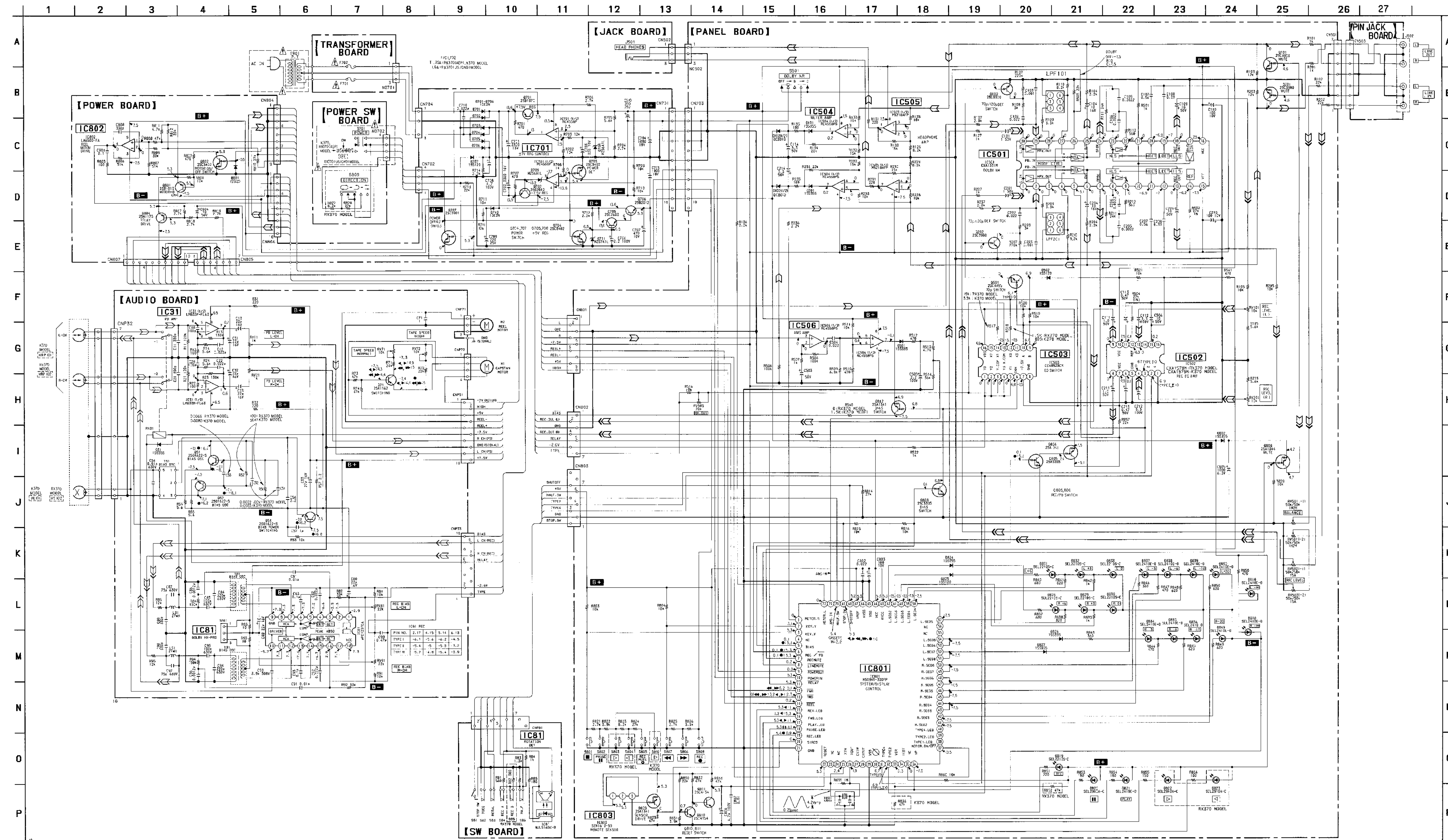

IC502
CX1578M
CX1579M

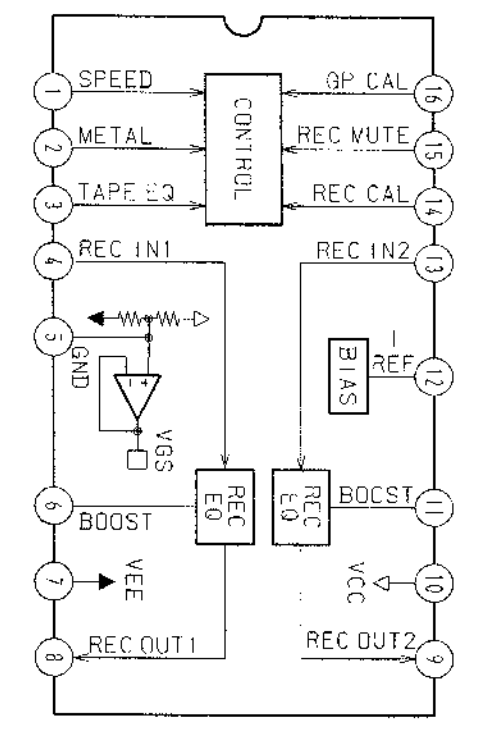

Note:

- All capacitors are in μF unless otherwise noted. pF : μF 50WV or less are not indicated except for electrolytics and tantalums.
- All resistors are in Ω and $\frac{1}{2}\text{W}$ or less unless otherwise specified.
- % : indicates tolerance.

Note:
The components identified by mark Δ or dotted line with mark Δ are critical for safety. Replace only with part number specified.

Note:
Les composants identifiés par une marque Δ ou une ligne pointillée avec une marque Δ sont critiques pour la sécurité. Ne les remplacer que par une pièce portant le numéro spécifié.

- Δ : Internal component.
- B+** : B+ Line
- B-** : B- Line
- \square : adjustment for repair.
- Voltage and waveforms are dc with respect to ground under no-signal (detuned) conditions. no mark: STOP
- Signal path: \curvearrowright : PB, \curvearrowleft : REC
- \blacktriangleright : FWD, \blacktriangleleft : REV, \bullet : REC
- \blacktriangleright : FF, \blacktriangleleft : REW
- Voltages are taken with a VOM (input impedance 10M Ω). Voltage variations may be noted due to normal production tolerances.
- CND : Canadian
- T370:TC-K370
- RX370:TC-RX370

**SECTION 5
EXPLODED VIEWS**

NOTE:

- -X, -X mean standardized parts, so they may have some differences from the original one.
- The mechanical parts with no reference number in the exploded views are not supplied.
- Items marked "*" are not stocked since they are seldom required for routine service. Some delay should be anticipated when ordering these items.

● Color Indication of Appearance Parts
Example:
KNOB, BALANCE(WHITE)...(RED)
↑ ↑
Part's Color Cabinet's Color

● Hardware (#mark) list is given in the last of this parts list.

● CND: Canadian
● G: Germany
● AUS: Australian
● K370:TC-K370
● RX370:TC-RX370

The components identified by mark **A** or dotted line with mark **A** are critical for safety. Replace only with part number specified.

Les composants identifiés par une marque **A** sont critiques pour la sécurité. Ne les remplacer que par une pièce portant le numéro spécifié.

5-1. CHASSIS SECTION

- A: TRANSFORMER board
- B: POWER board
- C: PIN JACK board

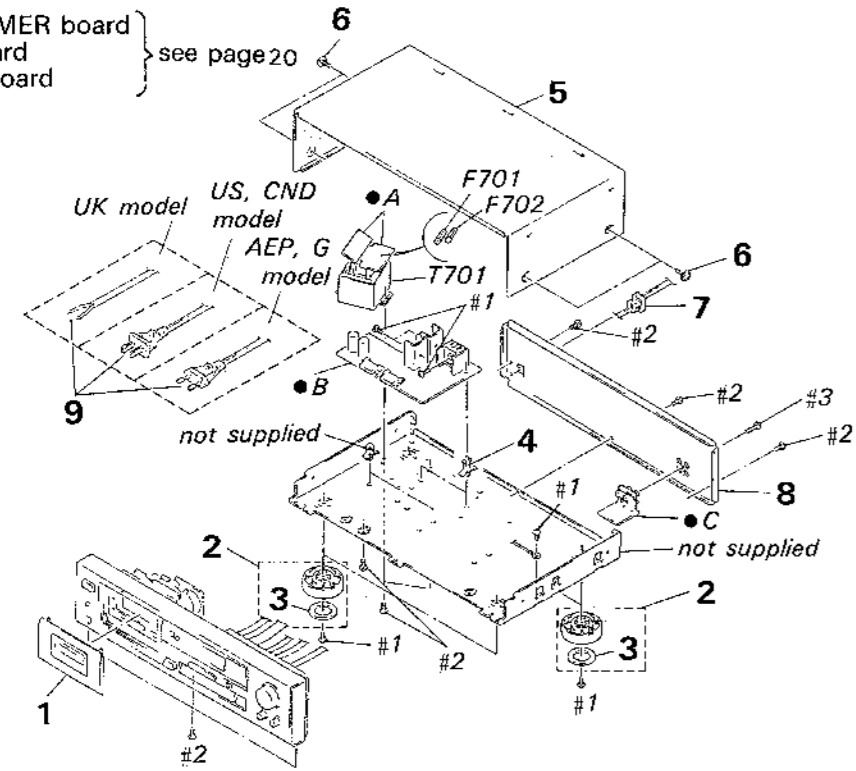

5-2. FRONT PANEL SECTION

- D: POWER SW board
- E: JACK board

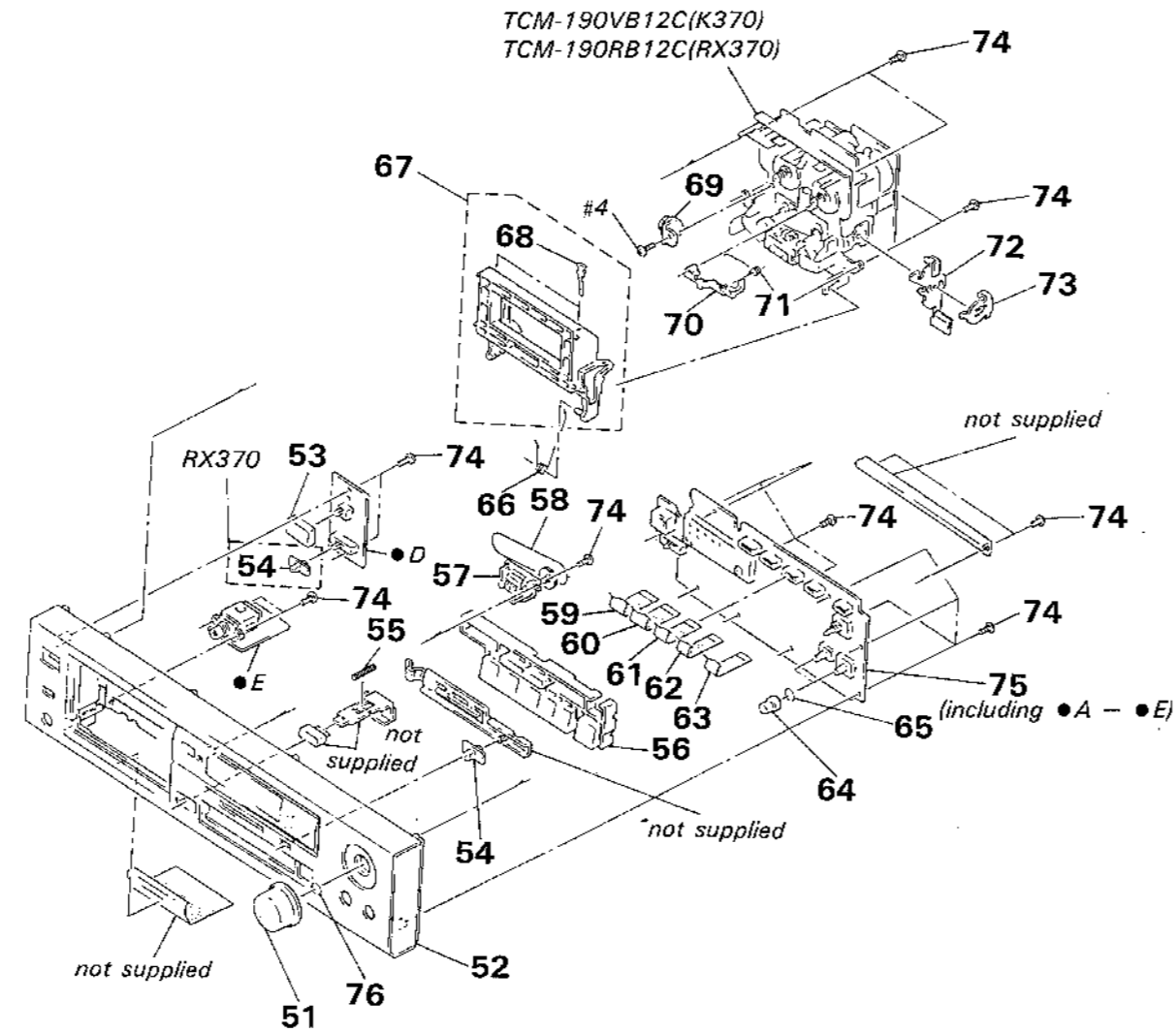

5-3. MECHANISM SECTION 1

- TCM-190VB12C(TC-K370)
- TCM-190RB12C(TC-RX370)

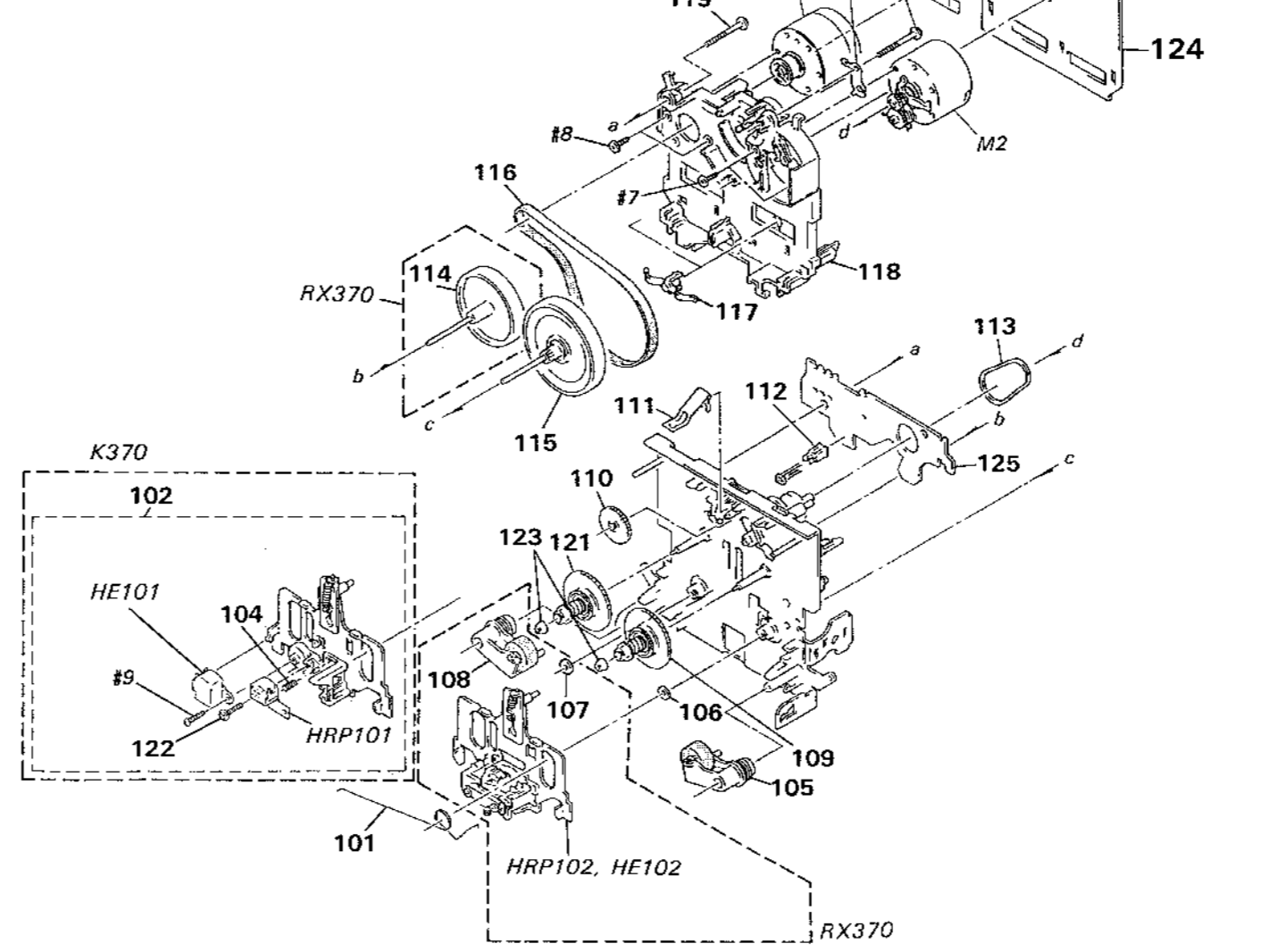

5-4. MECHANISM SECTION 2

- TCM-190VB12C(TC-K370)
- TCM-190RB12C(TC-RX370)

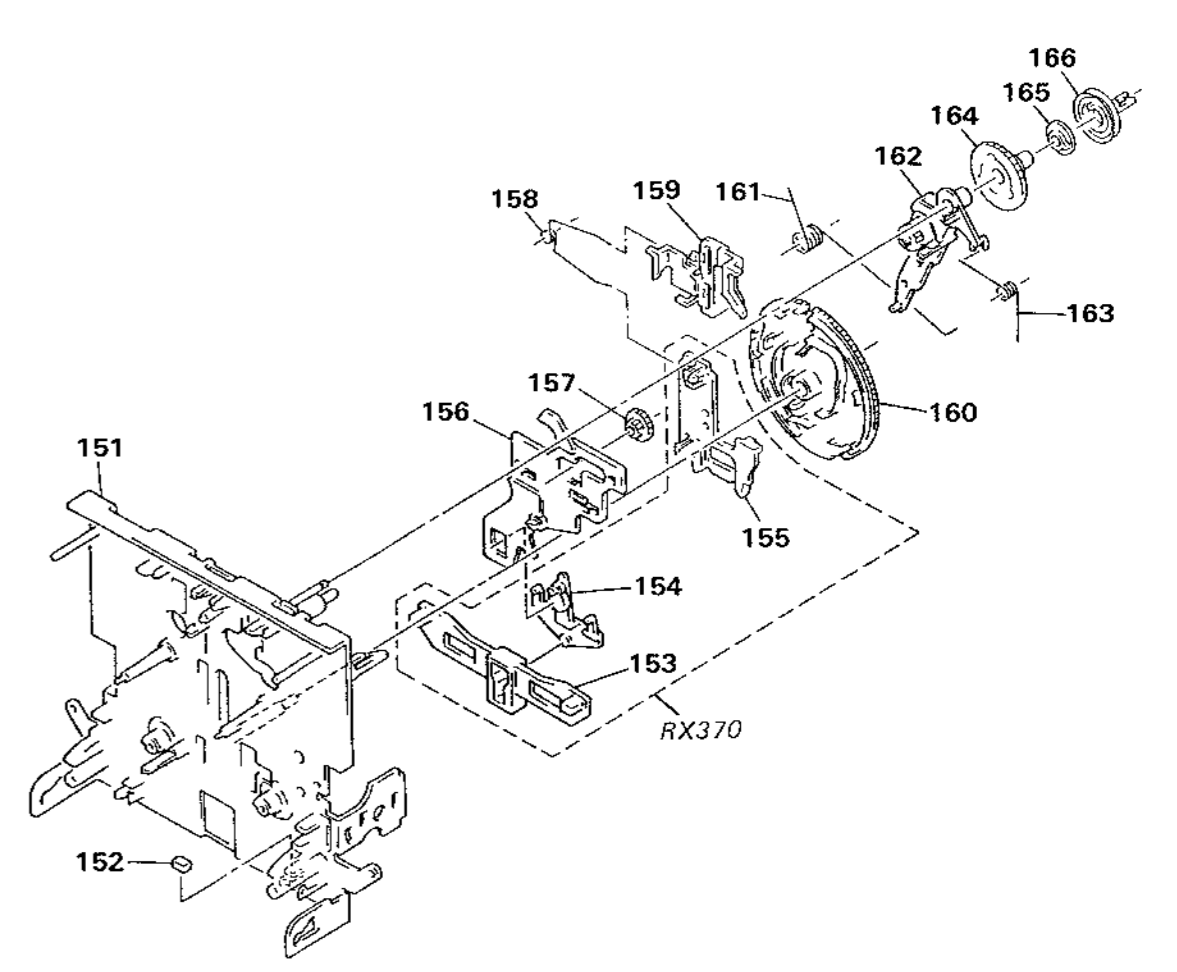

Ref. No.	Part No.	Description	Remark
1	X-3363-329-1	LID ASSY (R), CASSETTE (RX370)	
1	X-3363-329-1	LID ASSY (V), CASSETTE (K370)	
2	X-3384-898-2	FOOT ASSY (RX370:AEP/K370)	
2	X-4885-959-1	FOOT ASSY (RX370:US,Canadian)	
3	4-829-836-11	CUSHION	
4	* 3-345-265-11	HOLDER, PC BOARD	
5	3-332-578-81	CASE	
6	3-704-366-91	SCREW (CASE) (MX8)	
7	* 3-703-242-00	BUSHING (2104), CORD (RX370:AEP/K370)	
7	* 3-703-571-11	BUSHING (S) (4516), CORD (RX370:US,Canadian)	
8	* 3-367-827-02	PANEL, BACK (K370:AEP, G)	
8	* 3-367-827-12	PANEL, BACK (K370:AEP)	
8	* 3-367-827-22	PANEL, BACK (K370:UK, AUS)	
8	* 3-367-828-02	PANEL, BACK (RX370:US,Canadian)	
8	* 3-367-828-12	PANEL, BACK (RX370:AEP)	
8	* 3-367-828-22	PANEL, BACK (RX370:AEP)	

Ref. No.	Part No.	Description	Remark
9	▲ 1-551-506-XX	CORD, POWER (RX370:US,Canadian)	
9	▲ 1-555-795-00	CORD, POWER, EURO PLUG (K370:AEP, G/RX370:AEP)	
9	▲ 1-566-035-00	CORD, POWER (K370:UK, AUS)	
F701	▲ 1-532-285-00	FUSE, TIME-LAG (T1.25A) (RX370:AEP/K370)	
F702	▲ 1-532-741-11	FUSE, GLASS TUBE (1.6A) (RX370:US,Canadian)	
F702	▲ 1-532-285-00	FUSE, TIME-LAG (T1.25A) (RX370:AEP/K370)	
F702	▲ 1-532-741-11	FUSE, GLASS TUBE (1.6A) (RX370:US,Canadian)	
T901	▲ 1-450-505-11	TRANSFORMER, POWER (RX370:US,Canadian)	
T901	▲ 1-460-507-11	TRANSFORMER, POWER (RX370:AEP/K370)	

Ref. No.	Part No.	Description	Remark
51	3-367-438-11	KNOB (REC)	
52	X-3363-327-2	PANEL ASSY, FRONT (RX370:US,Canadian)	
52	X-3363-328-2	PANEL ASSY, FRONT (RX370:AEP)	
52	X-3363-330-2	PANEL ASSY, FRONT (K370)	
53	4-922-921-01	BUTTON (POWER)	
54	4-922-518-01	KNOB (TIMER)	
55	3-359-906-01	SPRING, COMPRESSION	
F702	▲ 1-532-285-00	FUSE, TIME-LAG (T1.25A) (RX370:AEP/K370)	
F702	▲ 1-532-741-11	FUSE, GLASS TUBE (1.6A) (RX370:US,Canadian)	
T901	▲ 1-450-505-11	TRANSFORMER, POWER (RX370:US,Canadian)	
T901	▲ 1-460-507-11	TRANSFORMER, POWER (RX370:AEP/K370)	
57	1-548-595-71	COUNTER, TAPE (MIDDLE TYPE)	
58	3-330-314-01	BELT (DIA. 57X1.2)	
59	1-575-782-11	WIRE, FLAT TYPE (9 CORE)	
60	1-590-046-11	WIRE, FLAT TYPE (11 CORE)	
61	1-680-045-11	WIRE, FLAT TYPE (9 CORE)	

Ref. No.	Part No.	Description	Remark
62	1-690-047-11	WIRE, FLAT TYPE (7 CORE)	
63	1-590-963-11	WIRE, SHIELD, FLAT TYPE	
64	3-367-431-01	KNOB (BAL)	
65	3-356-957-01	SPRING (RX370)	
65	3-354-950-01	SPRING (LOADING R), TORSION	
67	X-3340-195-11	HOLDER (R) ASSY, CASSETTE	
68	3-308-823-11	SPRING	
69	3-364-963-01	DAMPER	
70	3-354-956-01	LEVER (EJ SAFTY LEVER R)	
71	3-354-952-01	SPRING (EJ SAFTY SPRING R)	
72	* 3-354-954-01	LEVER (LOCK LEVER R)	
73	3-354-957-01	JOINT (LOCK LEVER)	
74	4-928-635-01	SCREW, +BV (2.6XS) TAPPING	
75	* A-2006-509-A	PANEL BOARD, COMPLETE (K370)	
75	* A-2006-510-A	PANEL BOARD, COMPLETE (RX370)	
76	3-350-426-01	SPRING	

Ref. No.	Part No.	Description	Remark
101	3-359-455-01	SPRING, TORSION	
102	A-2003-817-A	BASE (ONE) ASSY, HEAD (K370)	
103	1-638-983-11	PC BOARD, MOTOR FLEXIBLE	
104	3-343-484-01	SPRING, COMPRESSION (K370)	
105	X-3359-408-1	LEVER (PINCH LEVER FWD) ASSY	
106	3-356-713-01	WASHER	
107	3-356-714-01	WASHER (RX370)	
108	X-3359-409-1	LEVER (PINCH LEVER REV) ASSY (RX370)	
109	X-3359-404-1	TABLE ASSY, REEL	
110	3-359-424-01	GEAR (REV GEAR)	
111	3-359-430-01	SPRING (CASSETTE RETAINER), LEAF	
112	3-343-419-01	HOLDER (S SENSER A)	
113	3-359-466-01	BELT (FR), SQUARE	
114	X-3359-410-1	FLYWHEEL (REV) ASSY (RX370)	
115	X-3359-408-1	FLYWHEEL (FWD) COMPLETE ASSY	
116	3-359-417-01	BELT (FLAT), CAPSTAN (RX370)	
116	3-359-467-01	BELT (1 WAY FLAT BELT) (K370)	

Ref. No.	Part No.	Description	Remark
117	3-575-321-00	RETAINER, THRUST, CAPSTAN	
118	* 3-359-436-01	BASE (THRUST RETAINER), FITTING	
119	3-359-414-01	SCREW (+PTPHW 2X2)	
120	3-359-450-01	PLATE, GROUND	
121	X-3362-078-11	TABLE ASSY (G), REEL	
122	3-359-446-01	SCREW (AZIMUTH ADJUSTMENT) (K370)	
123	3-362-308-01	CAP (REEL)	
124	* A-2006-401-A	AUDIO BOARD, COMPLETE (RX370)	
124	* A-2006-508-A	AUDIO BOARD, COMPLETE (K370)	
125	* 1-634-841-11	SW BOARD	
HE101	1-543-505-11	HEAD, MAGNETIC (ERASE) (K370)	
HE102	A-2003-838-A	BASE ASSY, HEAD (RX370)	
HRP101	1-543-507-11	HEAD, MAGNETIC (REC/PS) (K370)	
HRP102	A-2003-838-A	BASE ASSY, HEAD (RX370)	
M1	X-3359-417-1	MOTOR (CAPSTAN) ASSY	
M2	A-2003-474-A	MOTOR (REEL) ASSY	

Ref. No.	Part No.	Description	Remark
151	X-3359-415-1	CHASSIS ASSY, MECHANICAL (RX370)	
151	X-3359-416-1	CHASSIS ASSY, MECHANICAL (K370)	
152	3-359-469-01	SPACER	
153	* 3-359-425-01	SLIDER (REVERSE SLIDER) (RX370)	
154	3-359-426-01	LEVER (REVERSE LEVER) (RX370)	
155	* 3-359-427-01	SLIDER (LEVERSE SLIDER) (RX370)	
156	* 3-359-415-01	SLIDER (TRIGGER SLIDER)	
157	3-359-448-01	GEAR (TRIGGER)	

Ref. No.	Part No.	Description	Remark
158	3-359-454-01	SPRING, TORSION	
159	3-359-429-01	SLIDER (BRAKE PLATE)	
160	3-359-423-01	GEAR (CAM GEAR)	
161	3-359-456-01	SPRING (TRIGGER SPRING), TORSION	
162	X-3359-405-1	LEVER (FR ARM) ASSY	
163	3-359-453-01	SPRING (FR ARM), TORSION	
164	3-359-419-01	GEAR (FR GEAR)	
165	3-359-421-01	CLUTCH (REEL DISK)	
166	3-359-418-01	PULLEY (FR PULLEY)	

SECTION 6 ELECTRICAL PARTS LIST

AUDIO

NOTE:

- Due to standardization, replacements in the parts list may be different from the parts specified in the diagrams or the components used on the set.
- Items marked "*" are not stocked since they are seldom required for routine service. Some delay should be anticipated when ordering these items.
- -XX, -X mean standardized parts, so they may have some differences from the original one.
- RESISTORS
All resistors are in ohms

METAL: Metal-film resistor
METAL OXIDE: Metal Oxide-film resistor
F: nonflammable

● SEMICONDUCTORS

In each case, u: μ , for example:
uA...: μ A..., uPA...: μ P A...,
uPB...: μ P B..., uPC...: μ P C...,
uPD...: μ P D...

● CAPACITORS

uF: μ F

● COILS

uH: μ H

- CND: Canadian
- G: Germany
- AUS: Australian
- K370:TC-K370
- RX370:TC-RX370

The components identified by mark or dotted line with mark are critical for safety. Replace only with part number specified.

Les composants identifiés par une marque sont critiques pour la sécurité. Ne les remplacer que par une pièce portant le numéro spécifié.

Ref. No.	Part No.	Description	Remark	Ref. No.	Part No.	Description	Remark
	* A-2006-401-A	AUDIO BOARD, COMPLETE (RX370)		C86	1-163-143-00	CERAMIC CHIP	0.0012uF 5% 50V
	* A-2006-508-A	AUDIO BOARD, COMPLETE (K370)		C87	1-136-273-91	FILM	75PF 5% 630V
	***** < CAPACITOR >			C88	1-163-003-11	CERAMIC CHIP	330PF 10% 50V
C11	1-163-131-00	CERAMIC CHIP	330PF 5% 50V	C89	1-124-234-00	ELECT	22uF 20% 16V
C12	1-136-157-00	FILM	0.022uF 5% 50V	C90	1-107-045-00	MICA	3.9PF 500V
C13	1-124-234-00	ELECT	22uF 20% 16V	C91	1-164-232-11	CERAMIC CHIP	0.01uF 50V
C18	1-163-117-00	CERAMIC CHIP	100PF 5% 50V	C92	1-136-157-00	FILM	0.022uF 5% 50V
C21	1-163-131-00	CERAMIC CHIP	330PF 5% 50V	C93	1-164-004-11	CERAMIC CHIP	0.1uF 10% 25V
C22	1-136-157-00	FILM	0.022uF 5% 50V	C94	1-136-437-11	FILM	220PF 5% 630V
C23	1-124-234-00	ELECT	22uF 20% 16V	C95	1-136-433-11	FILM	100PF 5% 630V
C28	1-163-117-00	CERAMIC CHIP	100PF 5% 50V	C96	1-163-143-00	CERAMIC CHIP	0.0012uF 5% 50V
C31	1-124-234-00	ELECT	22uF 20% 16V	C97	1-136-273-91	FILM	75PF 5% 630V
C32	1-124-234-00	ELECT	22uF 20% 16V	C98	1-163-003-11	CERAMIC CHIP	330PF 10% 50V
C33	1-124-234-00	ELECT	22uF 20% 16V	C99	1-164-005-11	CERAMIC CHIP	0.47uF 25V
C51	1-164-161-11	CERAMIC CHIP	0.0022uF 10% 100V (RX370)	< CONNECTOR >			
C51	1-164-182-11	CERAMIC CHIP	0.0033uF 10% 50V (K370)	CNP31	* 1-580-782-11	CONNECTOR, BOARD TO BOARD	
C52	1-164-161-11	CERAMIC CHIP	0.0022uF 10% 100V (RX370)	CNP32	* 1-580-781-11	PIN, CONNECTOR (PC BOARD) 7P	
C52	1-164-182-11	CERAMIC CHIP	0.0033uF 10% 50V (K370)	CNP33	* 1-580-782-11	CONNECTOR, BOARD TO BOARD	
C53	1-163-019-00	CERAMIC CHIP	0.0068uF 10% 50V (RX370)	CNP71	* 1-564-719-11	PIN, CONNECTOR (SMALL TYPE) 3P	
C53	1-163-020-00	CERAMIC CHIP	0.0082uF 10% 50V (K370)	CNP72	* 1-580-411-11	SOCKET, CONNECTOR 4P	
C54	1-136-601-11	FILM	0.01uF 5% 630V	< DIODE >			
C56	1-164-505-11	CERAMIC CHIP	2.2uF 16V	D31	8-719-988-62	DIODE 1SS355	
C57	1-164-346-11	CERAMIC CHIP	1uF 16V	< IC >			
C71	1-164-346-11	CERAMIC CHIP	1uF 16V	IC31	8-759-970-66	IC LM833M	
C80	1-124-234-00	ELECT	22uF 20% 16V	IC81	8-759-106-56	IC uPC1297CA	
C81	1-164-232-11	CERAMIC CHIP	0.01uF 50V	< COIL >			
C82	1-136-157-00	FILM	0.022uF 5% 50V	L81	1-410-780-11	INDUCTOR	27mH
C83	1-164-004-11	CERAMIC CHIP	0.1uF 10% 25V	L91	1-410-780-11	INDUCTOR	27mH
C84	1-136-437-11	FILM	220PF 5% 630V				
C85	1-136-433-11	FILM	100PF 5% 630V				

AUDIO

PANEL

INCLUDING JACK, PIN JACK, POWER, POWER SW, TRANSFORMER

Ref. No.	Part No.	Description	Remark
< TRANSISTOR >			
Q51	8-729-808-01	TRANSISTOR 2SD1622-S	
Q52	8-729-808-01	TRANSISTOR 2SD1622-S	
Q53	8-729-808-01	TRANSISTOR 2SD1622-S	
Q71	8-729-216-22	TRANSISTOR 2SA1162-6	
< RESISTOR >			
R11	1-216-099-00	METAL CHIP 120K	5% 1/10W
R12	1-216-025-00	METAL CHIP 100	5% 1/10W
R13	1-216-100-00	METAL GLAZE 130K	5% 1/10W
R14	1-216-067-00	METAL CHIP 5.6K	5% 1/10W
R21	1-216-099-00	METAL CHIP 120K	5% 1/10W
R22	1-216-025-00	METAL CHIP 100	5% 1/10W
R23	1-216-100-00	METAL GLAZE 130K	5% 1/10W
R24	1-216-067-00	METAL CHIP 5.6K	5% 1/10W
R31	1-216-033-00	METAL CHIP 220	5% 1/10W
R32	1-216-033-00	METAL CHIP 220	5% 1/10W
R51	1-216-091-00	METAL CHIP 56K	5% 1/10W(K370)
R51	1-216-097-00	METAL CHIP 100K	5% 1/10W(RX370)
R52	1-216-091-00	METAL CHIP 56K	5% 1/10W(K370)
R52	1-216-097-00	METAL CHIP 100K	5% 1/10W(RX370)
R53	1-216-073-00	METAL CHIP 10K	5% 1/10W
R54	1-216-309-00	METAL CHIP 5.6	5% 1/10W
R55	1-216-309-00	METAL CHIP 5.6	5% 1/10W
R57	1-216-298-00	METAL CHIP 2.2	5% 1/10W
R71	1-216-082-00	METAL GLAZE 24K	5% 1/10W
R72	1-216-081-00	METAL CHIP 22K	5% 1/10W
R73	1-216-089-00	METAL CHIP 47K	5% 1/10W
R74	1-216-089-00	METAL CHIP 47K	5% 1/10W
R81	1-216-073-00	METAL CHIP 10K	5% 1/10W
R82	1-216-085-00	METAL CHIP 33K	5% 1/10W
R83	1-216-001-00	METAL CHIP 10	5% 1/10W
R84	1-216-101-00	METAL CHIP 150K	5% 1/10W
R85	1-216-075-00	METAL CHIP 12K	5% 1/10W
R91	1-216-073-00	METAL CHIP 10K	5% 1/10W
R92	1-216-085-00	METAL CHIP 33K	5% 1/10W
R93	1-216-001-00	METAL CHIP 10	5% 1/10W
R94	1-216-101-00	METAL CHIP 150K	5% 1/10W
R95	1-216-075-00	METAL CHIP 12K	5% 1/10W

< VARIABLE RESISTOR >

RV11	1-238-012-11	RES. ADJ. CARBON 1K
RV21	1-238-012-11	RES. ADJ. CARBON 1K
RV71	1-238-016-11	RES. ADJ. CARBON 10K
RV72	1-238-016-11	RES. ADJ. CARBON 10K
RV81	1-238-548-11	RES. ADJ. CARBON 22K
RV91	1-238-548-11	RES. ADJ. CARBON 22K

Ref. No.	Part No.	Description	Remark
< RELAY >			
RY31	1-515-726-11	RELAY	
< TRANSFORMER >			
T51	1-406-417-11	COIL, BIAS OSCILLATION	
T81	1-433-367-11	TRANSFORMER, BIAS OSCILLATION	
T91	1-433-367-11	TRANSFORMER, BIAS OSCILLATION	
< TEST PIN >			
TP81	* 1-568-449-11	HOUSING, CONNECTOR(PC BOARD) 3P	

* A-2006-509-A PANEL BOARD, COMPLETE (INCLUDING JACK BOARD, PIN JACK BOARD, POWER BOARD, POWER SW BOARD, TRANSFORMER BOARD) (K370)			
* A-2006-510-A PANEL BOARD, COMPLETE (INCLUDING JACK BOARD, PIN JACK BOARD, POWER BOARD, POWER SW BOARD, TRANSFORMER BOARD) (RX370)			

* 1-533-213-31 HOLDER, FUSE			
* 4-363-147-00 HEAT SINK, H. PIN			
* 4-880-403-11 HEAT SINK			
< CAPACITOR >			
C101	1-126-301-11	ELECT 1uF	20% 50V
C102	1-136-157-00	FILM 0.022uF	5% 50V
C103	1-163-009-11	CERAMIC CHIP 0.001uF	10% 50V
C104	1-126-157-11	ELECT 10uF	20% 16V
C105	1-130-475-00	MYLAR 0.0022uF	5% 50V
C106	1-130-475-00	MYLAR 0.0022uF	5% 50V
C107	1-136-174-00	FILM 0.56uF	5% 50V
C108	1-136-171-00	FILM 0.33uF	5% 50V
C109	1-124-907-11	ELECT 10uF	20% 50V
C110	1-124-443-00	ELECT 100uF	20% 10V
C111	1-124-903-11	ELECT 1uF	20% 50V
C112	1-123-382-00	ELECT 3.3uF	20% 100V
C113	1-124-902-00	ELECT 0.47uF	20% 50V
C114	1-126-162-11	ELECT 3.3uF	20% 50V
C201	1-126-301-11	ELECT 1uF	20% 50V
C202	1-136-157-00	FILM 0.022uF	5% 50V
C203	1-163-009-11	CERAMIC CHIP 0.001uF	10% 50V
C204	1-126-157-11	ELECT 10uF	20% 16V
C205	1-130-475-00	MYLAR 0.0022uF	5% 50V
C206	1-130-475-00	MYLAR 0.0022uF	5% 50V
C207	1-136-174-00	FILM 0.56uF	5% 50V
C208	1-136-171-00	FILM 0.33uF	5% 50V
C209	1-124-907-11	ELECT 10uF	20% 50V

PANEL

INCLUDING JACK, PIN JACK, POWER, POWER SW, TRANSFORMER

Ref. No.	Part No.	Description		Remark	Ref. No.	Part No.	Description		Remark
C210	1-124-443-00	ELECT	100uF	20% 10V	D501	8-719-988-62	DIODE 1SS355		
C211	1-124-903-11	ELECT	1uF	20% 50V	D502	8-719-912-20	DIODE 1SS120		
C212	1-123-382-00	ELECT	3.3uF	20% 100V	D701	8-719-200-77	DIODE 10E2N		
C213	1-124-902-00	ELECT	0.47uF	20% 50V	D702	8-719-200-77	DIODE 10E2N		
C214	1-126-162-11	ELECT	3.3uF	20% 50V	D703	8-719-200-77	DIODE 10E2N		
C503	1-124-903-11	ELECT	1uF	20% 50V	D704	8-719-200-77	DIODE 10E2N		
C504	1-163-494-00	CERAMIC	0.022uF	25V	D705	8-719-200-77	DIODE 10E2N		
C505	1-124-925-11	ELECT	2.2uF	20% 100V	D706	8-719-200-77	DIODE 10E2N		
C506	1-124-907-11	ELECT	10uF	20% 50V	D707	8-719-912-20	DIODE 1SS120		
C510	1-124-120-11	ELECT	220uF	20% 25V	D708	8-719-933-33	DIODE HZS6A1L		
C701	1-124-887-00	ELECT	3300uF	20% 16V	D709	8-719-933-33	DIODE HZS6A1L		
C702	1-124-887-00	ELECT	3300uF	20% 16V	D710	8-719-200-77	DIODE 10E2N		
C703	1-126-176-11	ELECT	220uF	20% 10V	D711	8-719-933-43	DIODE HZS7A1L		
C704	1-126-926-11	ELECT	1000uF	20% 10V	D801	8-719-912-20	DIODE 1SS120		
C705	1-126-926-11	ELECT	1000uF	20% 10V	D802	8-719-988-62	DIODE 1SS355		
C706	1-124-925-11	ELECT	2.2uF	20% 100V	D810	8-719-301-44	LED SEL2410E-D		
C707	1-124-472-11	ELECT	470uF	20% 10V	D818	8-719-301-44	LED SEL2410E-D		
C708	1-124-927-11	ELECT	4.7uF	20% 100V	D819	8-719-301-38	LED SEL2210S-C		
C709	1-124-120-11	ELECT	220uF	20% 25V	D820	8-719-301-52	LED SEL2810A-C		
C710	1-136-157-00	FILM	0.022uF	5% 50V	D821	8-719-301-44	LED SEL2410E-D		
C801	1-136-165-00	FILM	0.1uF	5% 50V	D822	8-719-301-52	LED SEL2810A-C (RX370)		
C802	1-163-097-11	CERAMIC CHIP	0.022uF	10% 25V	D823	8-719-301-52	LED SEL2810A-C (RX370)		
C803	1-126-177-11	ELECT	100uF	20% 10V	D824	8-719-988-62	DIODE 1SS355		
C804	1-124-907-11	ELECT	10uF	20% 50V	D825	8-719-912-20	DIODE 1SS120		
C805	1-126-916-11	ELECT	1000uF	20% 5.3V	D826	8-719-988-62	DIODE 1SS355		
C806	1-124-927-11	ELECT	4.7uF	20% 100V	D827	8-719-988-62	DIODE 1SS355		
C807	1-164-232-11	CERAMIC CHIP	0.01uF	50V	D828	8-719-301-38	LED SEL2210S-C		
C808	1-162-288-31	CERAMIC	330PF	10% 50V	D829	8-719-301-38	LED SEL2210S-C		
< CONNECTOR >									
CN501	* 1-568-826-11	SOCKET, CONNECTOR 7P			D832	8-719-301-38	LED SEL2210S-C		
CN502	* 1-573-262-11	PIN, CONNECTOR			D833	8-719-301-38	LED SEL2210S-C		
CN503	* 1-568-826-11	SOCKET, CONNECTOR 7P			D834	8-719-301-44	LED SEL2410E-D		
CN701	* 1-568-830-11	SOCKET, CONNECTOR 11P			D835	8-719-301-44	LED SEL2410E-D		
CN702	* 1-564-338-00	PIN, CONNECTOR 4P			D836	8-719-301-44	LED SEL2410E-D		
CN703	* 1-568-830-11	SOCKET, CONNECTOR 11P			D837	8-719-301-44	LED SEL2410E-D		
CN704	* 1-573-262-11	PIN, CONNECTOR			D838	8-719-301-44	LED SEL2410E-D		
CN801	* 1-568-828-11	SOCKET, CONNECTOR 9P			D839	8-719-301-44	LED SEL2410E-D		
CN802	* 1-568-826-11	SOCKET, CONNECTOR 7P			D849	8-719-301-44	LED SEL2410E-D		
CN803	* 1-568-828-11	SOCKET, CONNECTOR 9P			D850	8-719-301-44	LED SEL2410E-D		
CN804	* 1-568-828-11	SOCKET, CONNECTOR 9P			< IC >				
CN805	* 1-568-826-11	SOCKET, CONNECTOR 7P			IC501	8-752-055-08	IC CXA1331M		
CN806	* 1-580-824-11	CONNECTOR, BOARD TO BOARD			IC502	8-752-055-60	IC CXA1578M (RX370)		
CN807	* 1-580-824-11	CONNECTOR, BOARD TO BOARD			IC502	8-752-055-63	IC CXA1579M (K370)		
< DIODE >									
D101	8-719-988-62	DIODE 1SS355			IC503	8-759-516-41	IC CD4052BCM		
D102	8-719-990-39	DIODE DCB010			IC504	8-759-981-95	IC RC4558S		
D201	8-719-988-62	DIODE 1SS355			IC505	8-759-636-55	IC M5218AFP		

PANEL

INCLUDING JACK, PIN JACK, POWER, POWER SW, TRANSFORMER

Ref. No.	Part No.	Description	Remark	Ref. No.	Part No.	Description	Remark
IC5C6	8-759-981-95	IC RC4558S		Q701	8-729-924-90	TRANSISTOR 2SB1370-EF	
IC701	8-759-945-58	IC RC4558P		Q702	8-729-209-15	TRANSISTOR 2SD2012	
IC801	8-759-636-68	IC M50940-330FP		Q703	8-729-900-80	TRANSISTOR DTC114ES	
IC802	8-759-803-42	IC LA6500-FA		Q704	8-729-900-80	TRANSISTOR DTC114ES	
IC803	8-741-100-48	IC SBX1610-59		Q705	8-729-620-05	TRANSISTOR 2SC2603-EF	
< JACK >							
J501	1-507-981-11	JACK (LARGE TYPE) (HEAD PHONES)		Q706	8-729-209-15	TRANSISTOR 2SD2012	
J502	1-565-258-11	JACK, PIN 4P (LINE IN/OUT)		Q707	8-729-900-74	TRANSISTOR DTC143TS	
< JUMPER >							
JW301	1-216-295-00	METAL CHIP	0 5% 1/10W	Q801	8-729-801-84	TRANSISTOR 2SB1013-4	
JW302	1-216-295-00	METAL CHIP	0 5% 1/10W	Q802	8-729-900-80	TRANSISTOR DTC114ES	
JW303	1-216-295-00	METAL CHIP	0 5% 1/10W	Q803	8-729-805-45	TRANSISTOR 2SC3395	
JW304	1-216-295-00	METAL CHIP	0 5% 1/10W	Q804	8-729-119-76	TRANSISTOR 2SA1175-HFE	
JW305	1-216-295-00	METAL CHIP	0 5% 1/10W	Q805	8-729-805-45	TRANSISTOR 2SC3395	
JW306	1-216-295-00	METAL CHIP	0 5% 1/10W	Q806	8-729-805-69	TRANSISTOR 2SA1341	
JW307	1-216-295-00	METAL CHIP	0 5% 1/10W	Q808	8-729-805-65	TRANSISTOR 2SA1344	
JW308	1-216-295-00	METAL CHIP	0 5% 1/10W	Q809	8-729-805-69	TRANSISTOR 2SA1341	
JW309	1-216-295-00	METAL CHIP	0 5% 1/10W	Q810	8-729-602-21	TRANSISTOR 2SC4154-F	
JW310	1-216-295-00	METAL CHIP	0 5% 1/10W	Q811	8-729-602-21	TRANSISTOR 2SC4154-F	
JW311	1-216-295-00	METAL CHIP	0 5% 1/10W	Q812	8-729-805-69	TRANSISTOR 2SA1341	
JW312	1-216-295-00	METAL CHIP	0 5% 1/10W	< RESISTOR >			
JW313	1-216-295-00	METAL CHIP	0 5% 1/10W	R101	1-216-049-00	METAL CHIP 1K	5% 1/10W
JW314	1-216-296-00	METAL CHIP	0 5% 1/8W	R102	1-216-081-00	METAL CHIP 22K	5% 1/10W
JW315	1-216-296-00	METAL CHIP	0 5% 1/8W	R103	1-216-075-00	METAL CHIP 12K	5% 1/10W
JW316	1-216-296-00	METAL CHIP	0 5% 1/8W	R104	1-216-206-00	METAL GLAZE 2.2K	5% 1/8W
JW317	1-216-295-00	METAL CHIP	0 5% 1/10W	R105	1-216-073-00	METAL CHIP 10K	5% 1/10W
JW318	1-216-295-00	METAL CHIP	0 5% 1/10W	R107	1-216-105-00	METAL CHIP 220K	5% 1/10W
JW319	1-216-295-00	METAL CHIP	0 5% 1/10W	R108	1-216-060-00	METAL GLAZE 3K	5% 1/10W
JW320	1-216-295-00	METAL CHIP	0 5% 1/10W	R109	1-216-061-00	METAL CHIP 3.3K	5% 1/10W
JW321	1-216-295-00	METAL CHIP	0 5% 1/10W	R110	1-216-071-00	METAL CHIP 8.2K	5% 1/10W
JW322	1-216-295-00	METAL CHIP	0 5% 1/10W	R111	1-216-082-00	METAL GLAZE 24K	5% 1/10W
JW323	1-216-295-00	METAL CHIP	0 5% 1/10W	R112	1-216-043-00	METAL CHIP 560	5% 1/10W
JW324	1-216-295-00	METAL CHIP	0 5% 1/10W	R115	1-216-067-00	METAL CHIP 5.6K	5% 1/10W
JW325	1-216-295-00	METAL CHIP	0 5% 1/10W	R127	1-249-417-11	CARBON 1K	5% 1/4W
JW327	1-216-296-00	METAL CHIP	0 5% 1/8W	R128	1-216-073-00	METAL CHIP 10K	5% 1/10W
< FILTER >							
LPF101	1-239-087-11	FILTER, MPX		R129	1-216-071-00	METAL CHIP 8.2K	5% 1/10W
LPF201	1-239-087-11	FILTER, MPX		R130	1-216-077-00	METAL CHIP 15K	5% 1/10W
< TRANSISTOR >							
Q101	8-729-805-40	TRANSISTOR 2SC3900		R131	1-249-409-11	CARBON 220	5% 1/4W
Q102	8-729-805-40	TRANSISTOR 2SC3900		R132	1-216-077-00	METAL CHIP 15K	5% 1/10W
Q201	8-729-805-40	TRANSISTOR 2SC3900		R133	1-216-073-00	METAL CHIP 10K	5% 1/10W
Q202	8-729-805-40	TRANSISTOR 2SC3900		R134	1-216-081-00	METAL CHIP 22K	5% 1/10W
Q501	8-729-805-45	TRANSISTOR 2SC3395		R135	1-249-408-11	CARBON 180	5% 1/4W
				R136	1-249-421-11	CARBON 2.2K	5% 1/4W
				R137	1-247-838-00	CARBON 2K	5% 1/4W
				R201	1-216-049-00	METAL CHIP 1K	5% 1/10W
				R202	1-216-081-00	METAL CHIP 22K	5% 1/10W
				R203	1-216-075-00	METAL CHIP 12K	5% 1/10W
				R204	1-216-057-00	METAL CHIP 2.2K	5% 1/10W
				R205	1-216-073-00	METAL CHIP 10K	5% 1/10W
				R207	1-216-105-00	METAL CHIP 220K	5% 1/10W

PANEL

INCLUDING JACK, PIN JACK, POWER, POWER SW, TRANSFORMER

Ref. No.	Part No.	Description	Remark			Ref. No.	Part No.	Description	Remark		
R208	1-216-060-00	METAL GLAZE	3K	5%	1/10W	R706	1-249-422-11	CARBON	2.7K	5%	1/4W
R209	1-216-061-00	METAL CHIP	3.3K	5%	1/10W	R707	1-249-413-11	CARBON	470	5%	1/4W
R210	1-216-071-00	METAL CHIP	8.2K	5%	1/10W	R708	1-249-417-11	CARBON	1K	5%	1/4W
R211	1-216-082-00	METAL GLAZE	24K	5%	1/10W	R709	1-249-429-11	CARBON	10K	5%	1/4W
R212	1-216-043-00	METAL CHIP	560	5%	1/10W	R710	1-249-429-11	CARBON	10K	5%	1/4W
R215	1-216-067-00	METAL CHIP	5.6K	5%	1/10W	R711	1-249-429-11	CARBON	10K	5%	1/4W
R227	1-249-417-11	CARBON	1K	5%	1/4W	R712	1-249-421-11	CARBON	2.2K	5%	1/4W
R228	1-216-073-00	METAL CHIP	10K	5%	1/10W	R713	1-249-433-11	CARBON	22K	5%	1/4W
R229	1-216-071-00	METAL CHIP	8.2K	5%	1/10W	R714	1-249-421-11	CARBON	2.2K	5%	1/4W
R230	1-216-077-00	METAL CHIP	15K	5%	1/10W	R801	1-249-429-11	CARBON	10K	5%	1/4W
R231	1-249-409-11	CARBON	220	5%	1/4W	R802	1-249-413-11	CARBON	470	5%	1/4W
R232	1-249-431-11	CARBON	15K	5%	1/4W	R803	1-216-073-00	METAL CHIP	10K	5%	1/10W
R233	1-216-073-00	METAL CHIP	10K	5%	1/10W	R804	1-216-073-00	METAL CHIP	10K	5%	1/10W
R234	1-216-081-00	METAL CHIP	22K	5%	1/10W	R805	1-249-405-11	CARBON	100	5%	1/4W
R235	1-249-408-11	CARBON	180	5%	1/4W	R806	1-247-872-11	CARBON	51K	5%	1/4W
R236	1-249-421-11	CARBON	2.2K	5%	1/4W	R807	1-247-872-11	CARBON	51K	5%	1/4W
R237	1-247-838-00	CARBON	2K	5%	1/4W	R808	1-249-437-11	CARBON	47K	5%	1/4W
R501	1-216-049-00	METAL CHIP	1K	5%	1/10W	R809	1-247-866-11	CARBON	30K	5%	1/4W
R502	1-216-158-11	METAL GLAZE	27K	1%	1/10W	R810	1-249-434-11	CARBON	27K	5%	1/4W
R503	1-216-081-00	METAL CHIP	22K	5%	1/10W	R811	1-249-425-11	CARBON	4.7K	5%	1/4W
R504	1-216-455-00	METAL	27K	1%	1/6W	R812	1-247-862-11	CARBON	20K	5%	1/4W
R506	1-216-097-00	METAL CHIP	100K	5%	1/10W	R814	1-249-434-11	CARBON	27K	5%	1/4W
R507	1-216-049-00	METAL CHIP	1K	5%	1/10W	R815	1-216-073-00	METAL CHIP	10K	5%	1/10W
R508	1-216-097-00	METAL CHIP	100K	5%	1/10W	R816	1-216-073-00	METAL CHIP	10K	5%	1/10W
R509	1-216-069-00	METAL CHIP	6.8K	5%	1/10W	R817	1-249-422-11	CARBON	2.7K	5%	1/4W
R510	1-216-041-00	METAL CHIP	470	5%	1/10W	R818	1-249-422-11	CARBON	2.7K	5%	1/4W
R511	1-216-073-00	METAL CHIP	10K	5%	1/10W	R819	1-249-422-11	CARBON	2.7K	5%	1/4W
R512	1-216-041-00	METAL CHIP	470	5%	1/10W	R821	1-216-059-00	METAL CHIP	2.7K	5%	1/10W
R513	1-216-065-00	METAL CHIP	4.7K	5%	1/10W	R822	1-216-063-00	METAL CHIP	3.9K	5%	1/10W
R514	1-216-086-00	METAL GLAZE	36K	5%	1/10W	R823	1-216-071-00	METAL CHIP	8.2K	5%	1/10W
R516	1-216-073-00	METAL CHIP	10K	5%	1/10W	R824	1-216-083-00	METAL CHIP	27K	5%	1/10W
R517	1-216-069-00	METAL CHIP	6.8K	5%	1/10W	R825	1-249-422-11	CARBON	2.7K	5%	1/4W
R518	1-216-049-00	METAL CHIP	1K	5%	1/10W(K370)	R826	1-249-424-11	CARBON	3.9K	5%	1/4W
R518	1-216-053-00	METAL CHIP	1.5K	5%	1/10W(RX370)	R827	1-249-428-11	CARBON	8.2K	5%	1/4W(RX370)
R519	1-216-073-00	METAL CHIP	10K	5%	1/10W	R828	1-249-434-11	CARBON	27K	5%	1/4W(RX370)
R520	1-216-073-00	METAL CHIP	10K	5%	1/10W	R829	1-216-089-00	METAL CHIP	47K	5%	1/10W
R521	1-216-073-00	METAL CHIP	10K	5%	1/10W	R830	1-216-081-00	METAL CHIP	22K	5%	1/10W
R522	1-249-417-11	CARBON	1K	5%	1/4W	R831	1-216-063-00	METAL CHIP	3.9K	5%	1/10W
R540	1-216-053-00	METAL CHIP	1.5K	5%	1/10W(K370)	R832	1-216-089-00	METAL CHIP	47K	5%	1/10W
R540	1-216-295-00	METAL CHIP	0	5%	1/10W(RX370)	R833	1-216-089-00	METAL CHIP	47K	5%	1/10W
R541	1-216-041-00	METAL CHIP	470	5%	1/10W	R835	1-216-121-00	METAL CHIP	1M	5%	1/10W
R701	1-249-413-11	CARBON	470	5%	1/4W	R836	1-249-437-11	CARBON	47K	5%	1/4W(K370)
R702	1-249-429-11	CARBON	10K	5%	1/4W	R837	1-216-045-00	METAL CHIP	680	5%	1/10W
R703	1-249-430-11	CARBON	12K	5%	1/4W	R838	1-216-047-00	METAL CHIP	820	5%	1/10W
R704	1-249-422-11	CARBON	2.7K	5%	1/4W	R839	1-216-049-00	METAL CHIP	1K	5%	1/10W
R705	1-249-426-11	CARBON	5.6K	5%	1/4W	R840	1-216-045-00	METAL CHIP	680	5%	1/10W
						R841	1-216-047-00	METAL CHIP	820	5%	1/10W
						R842	1-216-049-00	METAL CHIP	1K	5%	1/10W
						R843	1-216-038-00	METAL CHIP	360	5%	1/10W

PANEL

INCLUDING JACK, PIN JACK, POWER, POWER SW, TRANSFORMER

SW

Ref. No.	Part No.	Description	Quantity	Remark
R844	1-216-041-00	METAL CHIP	470	5% 1/10W
R845	1-216-044-00	METAL CHIP	620	5% 1/10W
R846	1-216-038-00	METAL CHIP	360	5% 1/10W
R847	1-216-041-00	METAL CHIP	470	5% 1/10W
R848	1-216-044-00	METAL CHIP	620	5% 1/10W
R849	1-216-044-00	METAL CHIP	620	5% 1/10W
R850	1-216-044-00	METAL CHIP	620	5% 1/10W
R851	1-249-409-11	CARBON	220	5% 1/4W
R852	1-216-089-00	METAL CHIP	47K	5% 1/10W(RX370)
R853	1-249-408-11	CARBON	180	5% 1/4W
R854	1-216-031-00	METAL CHIP	180	5% 1/10W
R855	1-216-029-00	METAL CHIP	150	5% 1/10W
R856	1-216-031-00	METAL CHIP	180	5% 1/10W
R857	1-216-081-00	METAL CHIP	22K	5% 1/10W
R858	1-216-041-00	METAL CHIP	470	5% 1/10W
R859	1-216-073-00	METAL CHIP	10K	5% 1/10W
R860	1-216-073-00	METAL CHIP	10K	5% 1/10W

< VARIABLE RESISTOR >

RV101	1-238-600-11	RES. ADJ. CARBON 10K
RV201	1-238-600-11	RES. ADJ. CARBON 10K
RV501	1-241-523-11	RES. VAR. CARBON 50K/50K (BALANCE)
RV502	1-241-524-11	RES. VAR. CARBON 50K/50K (REC LEVEL)
RV503	1-241-525-11	RES. VAR. CARBON 20K (BIAS)

< SWITCH >

S501	1-572-268-11	SWITCH, SLIDE (DOLBY NR)
S701	△ 1-554-118-00	SWITCH, PUSH (1 KEY) (POWER)
S801	1-554-303-21	SWITCH, TACTILE (STOP)
S802	1-554-303-21	SWITCH, TACTILE (PAUSE)
S803	1-554-303-21	SWITCH, TACTILE (FWD) (RX370)
S804	1-554-303-21	SWITCH, TACTILE (REV) (RX370)
S805	1-554-303-21	SWITCH, TACTILE (REC MUTE)
S806	1-554-303-21	SWITCH, TACTILE (FF)
S807	1-554-303-21	SWITCH, TACTILE (REW)
S808	1-554-303-21	SWITCH, TACTILE (REC)
S809	1-571-520-11	SWITCH, SLIDE (DIRECTION) (RX370)
S810	1-554-303-21	SWITCH, TACTILE (FWD) (K370)

< CERAMIC >

X801	1-577-358-21	VIBRATOR, CERAMIC (4MHz)
------	--------------	--------------------------

* 1-634-841-11 SW BOARD

3-343-419-01 HOLDER (S SENSER A)

Ref. No.	Part No.	Description	Quantity	Remark
< CONNECTOR >				
CNP81	* 1-568-852-11	SOCKET, CONNECTOR 9P		
< IC >				
IC81	8-719-710-03	PHOTO INTERRUPTOR KJL5165X-B		
< RESISTOR >				
R81	1-249-414-11	CARBON	560	5% 1/4W
R82	1-247-818-11	CARBON	300	5% 1/4W(RX370)
R83	1-247-834-11	CARBON	1.3K	5% 1/4W
R84	1-249-417-11	CARBON	1K	5% 1/4W
R85	1-249-408-11	CARBON	180	5% 1/4W
< SWITCH >				
S81	1-571-958-11	SWITCH, PUSH (1 KEY) (STOP)		
S82	1-571-281-21	SWITCH, LEAF (70EQ)		
S83	1-571-281-21	SWITCH, LEAF (METAL)		
S84	1-571-281-21	SWITCH, LEAF (REC A)		
S85	1-571-281-21	SWITCH, LEAF (REC B) (RX370)		
S86	1-571-281-21	SWITCH, LEAF (HALF)		

MISCELLANEOUS

9	△ 1-551-506-XX	CORD, POWER (RX370:US, Canadian)
5	△ 1-555-795-00	CORD, POWER, EURO PLUG (K370:AEP, G/RX370:AEP)
9	△ 1-556-035-00	CORD, POWER (K370:UK)
57	1-548-596-71	COUNTER, TAPE (MIDDLE TYPE)
59	1-575-782-11	WIRE, FLAT TYPE (9 CORE)
60	1-690-046-11	WIRE, FLAT TYPE (11 CORE)
61	1-690-045-11	WIRE, FLAT TYPE (9 CORE)
62	1-690-047-11	WIRE, FLAT TYPE (7 CORE)
63	1-590-963-11	WIRE, SHIELD, FLAT TYPE
103	1-638-983-11	PC BOARD, MOTOR FLEXIBLE
F701	△ 1-532-285-00	FUSE, TIME-LAG (T1, 25A) (RX370:AEP/K370)
F701	△ 1-532-741-11	FUSE, GLASS TUBE (1.6A) (RX370:US, Canadian)
F702	△ 1-532-285-00	FUSE, TIME-LAG (T1, 25A) (RX370:AEP/K370)
F702	△ 1-532-741-11	FUSE, GLASS TUBE (1.6A) (RX370:US, Canadian)
HE101	1-543-535-11	HEAD, MAGNETIC (ERASE) (K370)
HE102	A-2003-838-A	BASE ASSY, HEAD (RX370)
HRP101	1-543-537-11	HEAD, MAGNETIC (REC/P8) (K370)
HRP102	A-2003-838-A	BASE ASSY, HEAD (RX370)
M1	X-3359-417-1	MOTOR (CAPSTAN) ASSY
M2	A-2003-474-A	MOTOR (REEL) ASSY
T901	△ 1-450-505-11	TRANSFORMER, POWER (RX370:US, Canadian)
T901	△ 1-450-507-11	TRANSFORMER, POWER (RX370:AEP/K370)

The components identified by mark **△** or dotted line with mark **△** are critical for safety. Replace only with part number specified.

Les composants identifiés par une marque **△** sont critiques pour la sécurité. Ne les remplacer que par une pièce portant le numéro spécifié.

Ref. No.	Part No.	Description	Remark
ACCESSORY & PACKING MATERIAL			

	1-559-533-11	CORD, CONNECTION	
*	3-350-830-01	CUSHION	
*	3-366-700-81	INDIVIDUAL CARTON (K370)	
*	3-366-700-91	INDIVIDUAL CARTON (RX370)	
	3-703-450-01	INSTRUCTION (RX370:US)	
*	3-704-343-01	SHEET (STANDARD). PROTECTION	
	3-753-518-11	MANUAL, INSTRUCTION (ENGLISH, FRENCH, SPANISH, PORTUGUESE) (RX370:Canadian, AEP)	
	3-753-518-21	MANUAL, INSTRUCTION (ENGLISH) (RX370:US)	
	3-753-518-41	MANUAL, INSTRUCTION (GERMAN, DUTCH, SWEDISH, ITALIAN) (RX370:AEP)	
	3-753-519-11	MANUAL, INSTRUCTION (ENGLISH, FRENCH, SPANISH, CHINESE) (K370:AEP, UK, AUS)	
	3-753-519-41	MANUAL, INSTRUCTION (GERMAN, DUTCH, SWEDISH, ITALIAN) (K370:AEP)	
	3-753-519-51	MANUAL, INSTRUCTION (GERMAN) (K370:G)	

HARDWARE LIST

# 1	7-682-548-04	SCREW +BVTT 3X8 (S)
# 2	7-682-548-09	SCREW +BVTT 3X8 (S)
# 3	7-621-849-00	SCREW (BV/RING)
# 4	7-621-773-95	SCREW +BVTT 2.6X6 (S)
# 7	7-627-556-08	SCREW +P 2.6X2.8
# 8	7-621-775-00	SCREW +8 2.6X3
# 9	7-621-772-58	SCREW (+82X10) (K370)

