

TC-R502/R502ES

SERVICE MANUAL

TC-R502:
US Model
Canadian Model

TC-R502ES:
AEP Model
UK Model
E Model

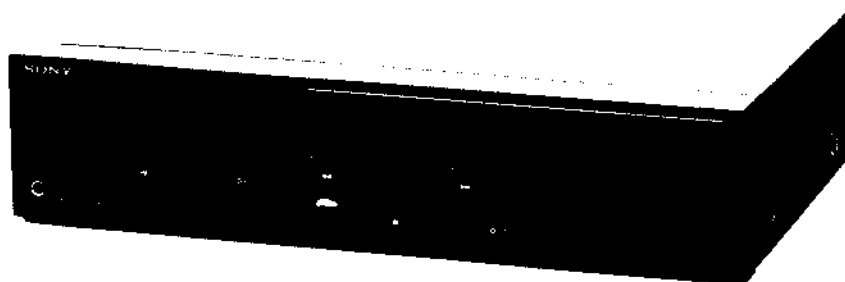

SPECIFICATIONS

Recording system 4-track 2-channel stereo
Fast-forward and rewind time
Approx. 90 sec. (with C-60 cassette)
Bias frequency 105 kHz
Signal-to-noise ratio
(NAB, at peak level)

Dolby NR switch Cassette	OFF	B-TYPE ON	C-TYPE ON
TYPE IV (Sony METAL-ES)	59 dB	66 dB	72 dB
TYPE II (Sony UCX-S)	58 dB	65 dB	71 dB
TYPE I (Sony HF-S)	54 dB	61 dB	67 dB

Total harmonic distortion
1.0% (with Sony METAL-ES cassettes)

Frequency response

DOLBY NR OFF

- With TYPE IV cassette (Sony METAL-ES)
30 - 17,000 Hz (± 3 dB)
- With TYPE II cassette (Sony UCX-S)
30 - 17,000 Hz (± 3 dB)
- With TYPE I cassette (Sony HF-S)
30 - 15,000 Hz (± 3 dB)

Wow and flutter

0.05% WRMS (NAB)

Inputs

Line inputs (phono jacks)
Sensitivity 77.5 mV (-20 dB)
Input impedance 50 k ohms

Outputs

Line outputs (phono jacks)
Rated output level 0.44 V (-5 dB) at load impedance 47 k ohms
Load impedance over 10 k ohms
Headphone output (stereo phone jack)
Output level variable from -20 dB to $-\infty$ dB
at load impedance of 8 ohms

General

Power requirements

US, Canadian model: 120 V ac, 60 Hz
AEP model: 220 V ac, 50/60 Hz
UK model: 240 V ac, 50/60 Hz
E model: 120, 220, 240 V ac adjustable, 50/60 Hz

Power consumption

20 watts

Dimensions

Approx. 430 x 105 x 285 mm (w/h/d)
(17 x 4 $\frac{1}{4}$ x 11 $\frac{1}{4}$ inches)
including projecting parts and controls

Weight

Approx. 4.7 kg (10 lbs 6 oz)

Supplied accessories

Connecting cord (2)
Remote control cord (1; 4-pin)

Design and specifications subject to change without notice.

SAFETY-RELATED COMPONENT WARNING!!

COMPONENTS IDENTIFIED BY SHADING AND MARK  ON THE SCHEMATIC DIAGRAMS AND IN THE PARTS LIST ARE CRITICAL TO SAFE OPERATION. REPLACE THESE COMPONENTS WITH SONY PARTS WHOSE PART NUMBERS APPEAR AS SHOWN IN THIS MANUAL OR IN SUPPLEMENTS PUBLISHED BY SONY.

ATTENTION AU COMPOSANT AYANT RAPPORT À LA SÉCURITÉ!

LES COMPOSANTS IDENTIFIÉS PAR UNE TRAME ET UNE MARQUE  SUR LES DIAGRAMMES SCHEMATIQUES ET LA LISTE DES PIÈCES SONT CRITIQUES POUR LA SÉCURITÉ DE FONCTIONNEMENT. NE REMPLACER CES COMPOSANTS QUE PAR DES PIÈCES SONY DONT LES NUMÉROS SONT DONNÉS DANS CE MANUEL OU DANS LES SUPPLÉMENTS PUBLIÉS PAR SONY.

STEREO CASSETTE DECK
SONY[®]



FEATURES

- The Dolby HX PRO* system improves the linearity of the tape's high range response during recording.
- The record/playback head is made of a laser amorphous magnetic alloy using LC-OFC winding.
- The roto-bilateral head assures the same performance characteristics in either tape transport direction.
- For optimum performance in the Dolby NR system, the recording level can be calibrated to the sensitivity of each tape played back.
- Quick reverse function prevents tape transport on the leader tape.
- The AMS, blank skip and music scan functions allow easy access to a desired selection.

- Timer-activated play/recording is possible using the optional timer.
- The optional remote control unit enables various operations to be remotely controlled.
- The digital linear counter indicates the recording or playback time which has elapsed on the tape.
- Bright FL-display peak program meters indicate the transient peaks.
- B and C type Dolby NR system reduces noise.

* "Dolby", the double-D symbol and HX PRO are trade marks of the Dolby Laboratories Licensing Corporation. Noise reduction and HX PRO headroom extension manufactured under license from Dolby Laboratories Licensing Corporation. HX PRO originated by Bang and Olufsen.

SAFETY CHECK-OUT (US Model)

After correcting the original service problem, perform the following safety check before releasing the set to the customer:

Check the antenna terminals, metal trim, "metallized" knobs, screws, and all other exposed metal parts for AC leakage. Check leakage as described below.

LEAKAGE TEST

The AC leakage from any exposed metal part to earth ground and from all exposed metal parts to any exposed metal part having a return to chassis, must not exceed 0.5 mA (500 microamperes). Leakage current can be measured by any one of three methods.

1. A commercial leakage tester, such as the Simpson 229 or RCA WT-540A. Follow the manufacturers' instructions to use these instruments.
2. A battery-operated AC milliammeter. The Data Precision 245 digital multimeter is suitable for this job.

3. Measuring the voltage drop across a resistor by means of a VOM or battery-operated AC voltmeter. The "limit" indication is 0.75 V, so analog meters must have an accurate low-voltage scale. The Simpson 250 and Sanwa SH-63Trd are examples of a passive VOM that is suitable. Nearly all battery operated digital multimeters that have a 2 V AC range are suitable. (See Fig. A)

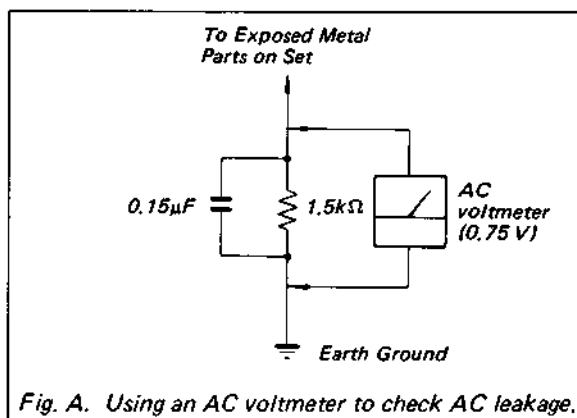
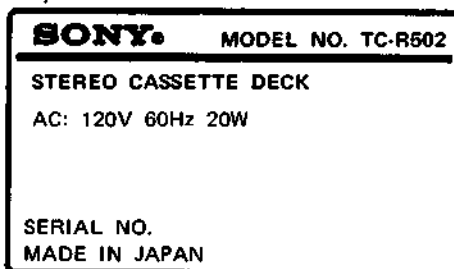

Fig. A. Using an AC voltmeter to check AC leakage.

MODEL IDENTIFICATION

— Specification Label —

US, Canadian model



AEP model

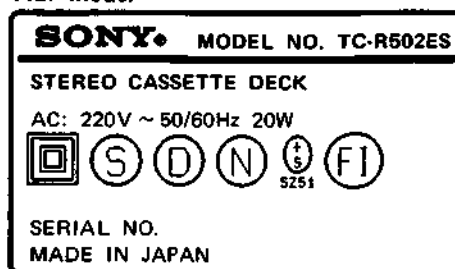

UK model

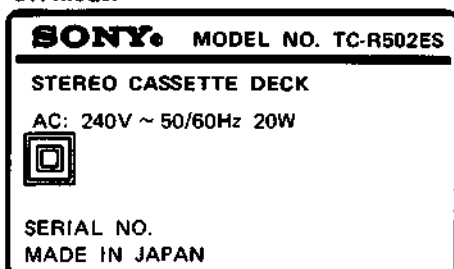

E model

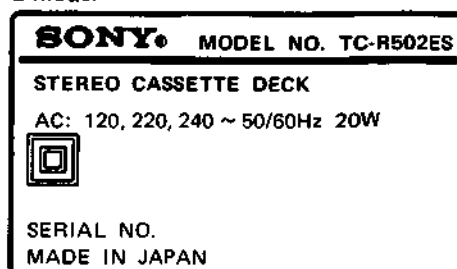

FUNCTION OF CONTROLS

Front panel

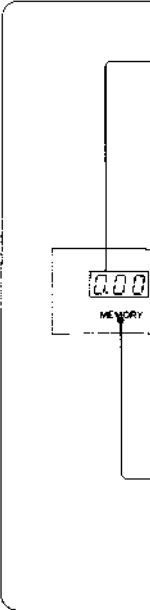
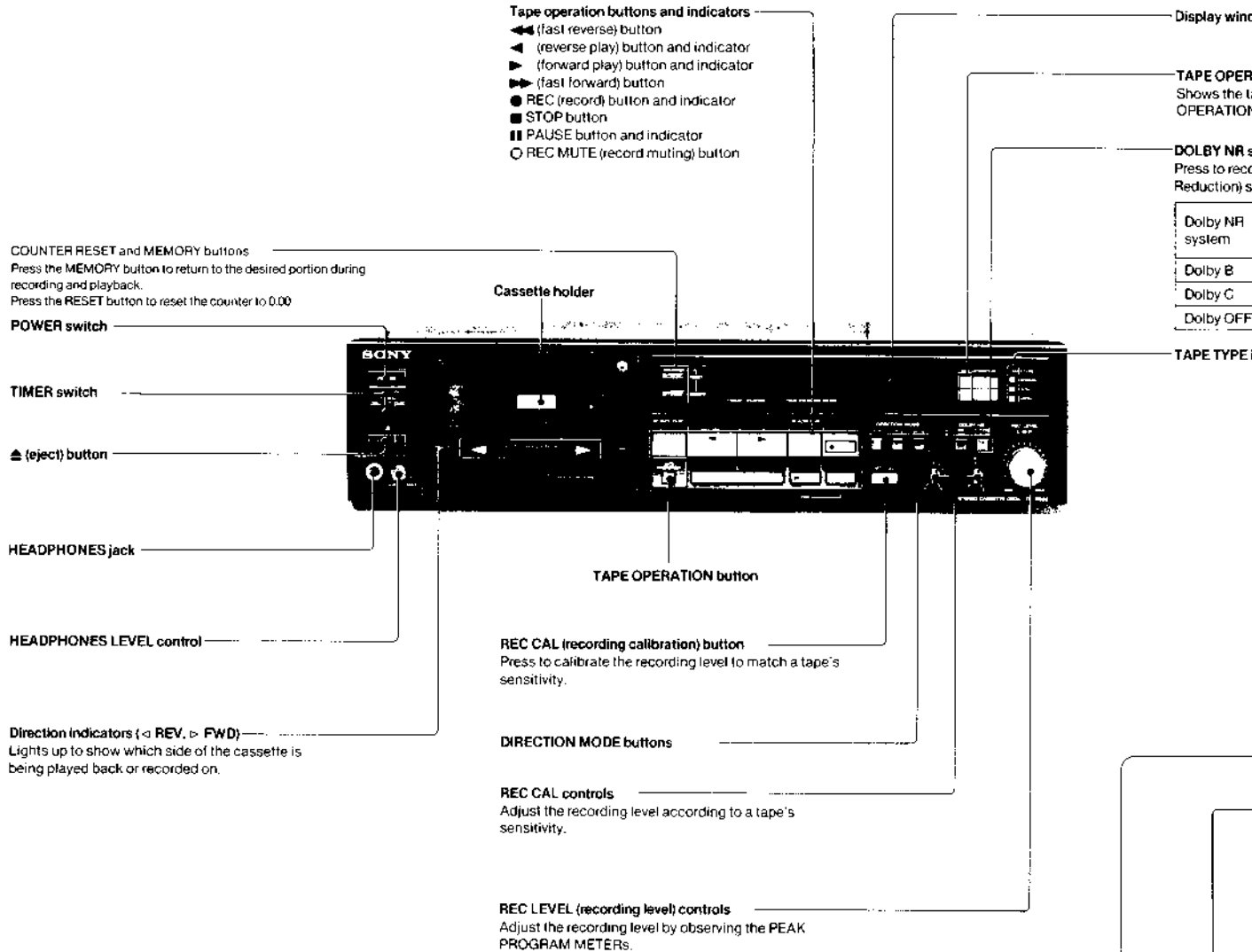

TC-R502/R502ES

Rear panel

OPERATION indicator
Indicates the operation selected with the TAPE button.

Switches
Switches for play back using the Dolby NR (Noise Reduction) system.

Switch setting	
Left switch	Right switch
☐ ON	☐ B-TYPE
☐ ON	☐ C-TYPE
☐ OFF	Either position

Indicator

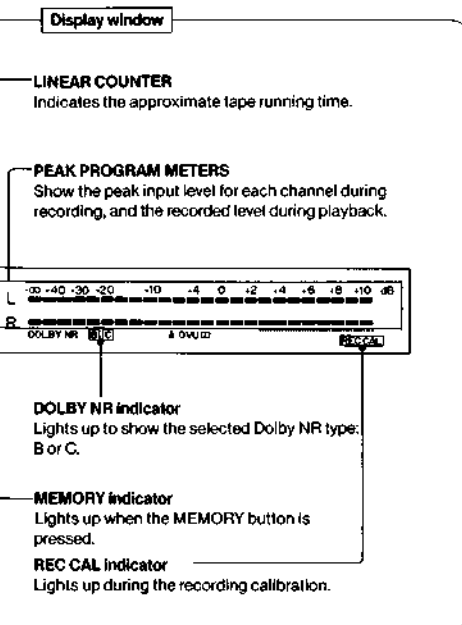
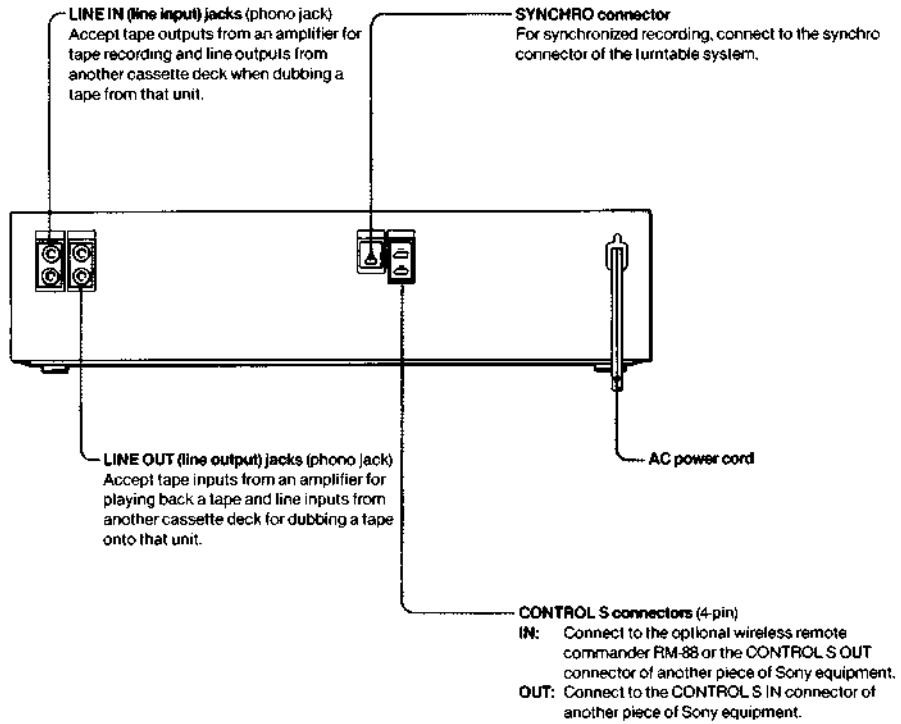

TC-R502/R502ES TC-R502/R502ES

SECTION 1 BLOCK DIAGRAM

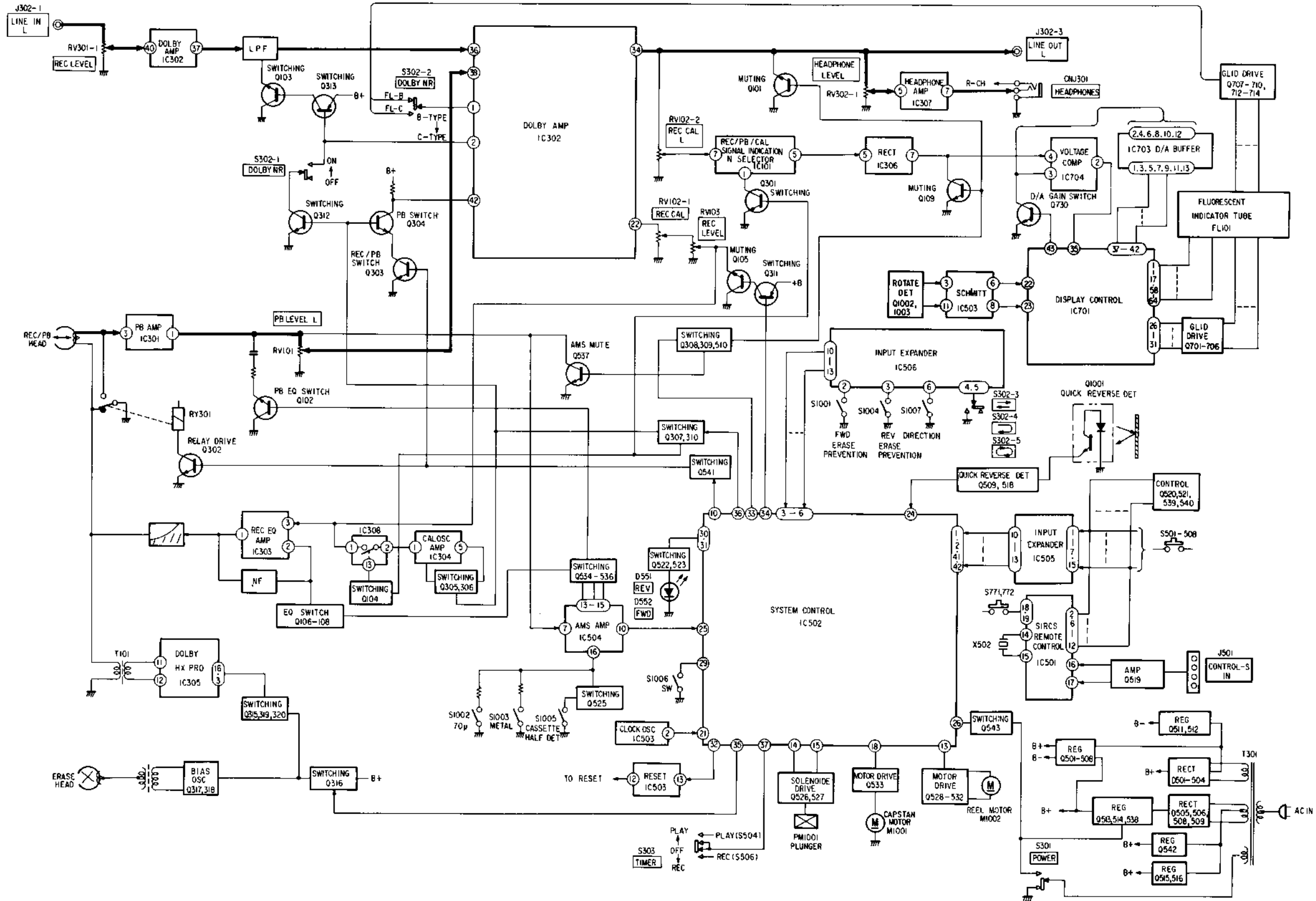

SECTION 2
DISASSEMBLY

• Follow the disassembly procedure in the numerical order given.

CASE
Remove four case screws.

CASSETTE WINDOW

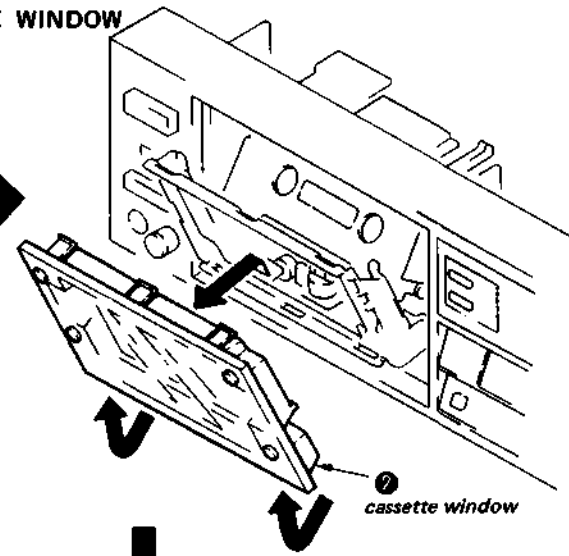

FRONT PANEL

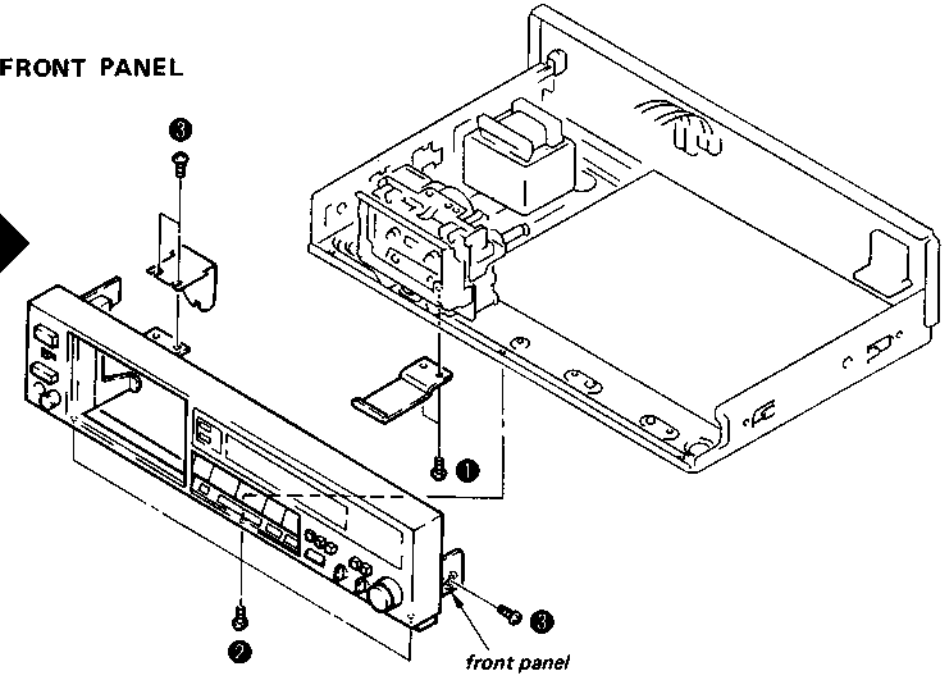

PINCH ROLLER

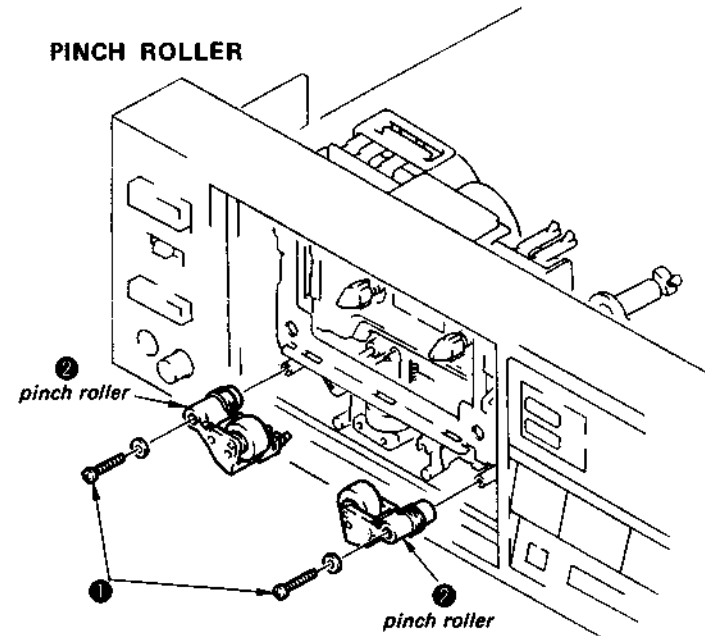

MECHANISM BLOCK

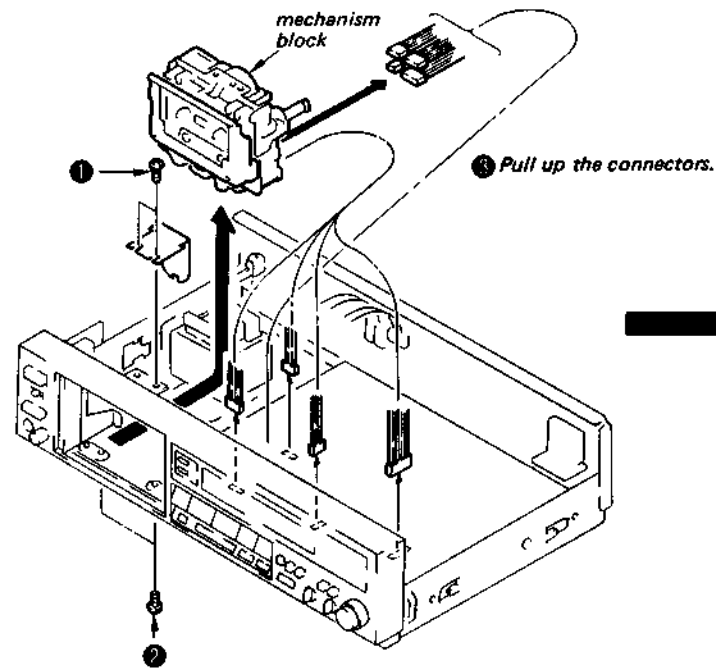

CASSETTE HOLDER

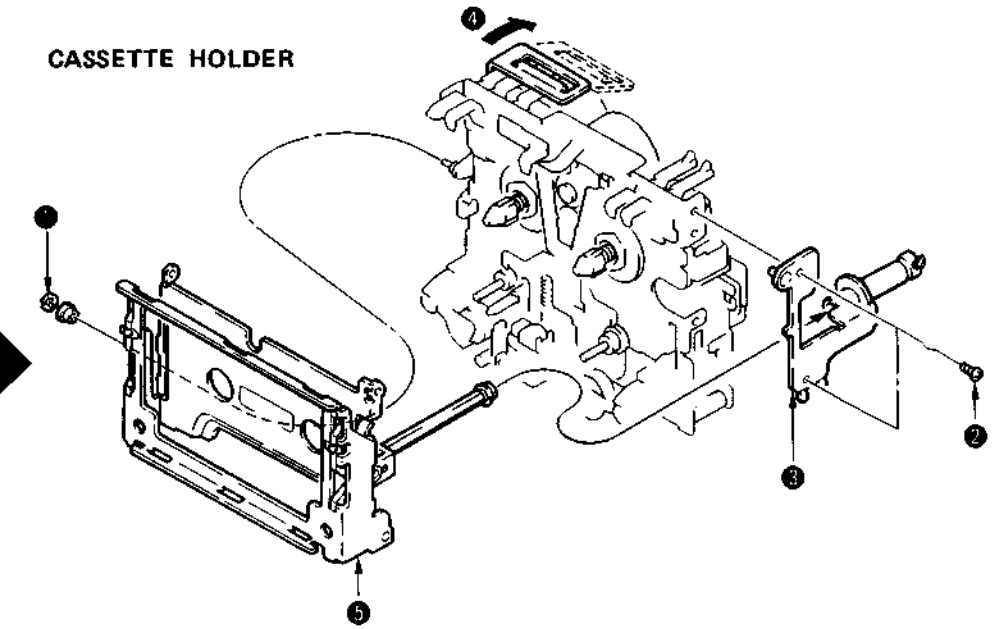

TC-R502/R502ES TC-R502/R502ES

DISPLAY BOARD

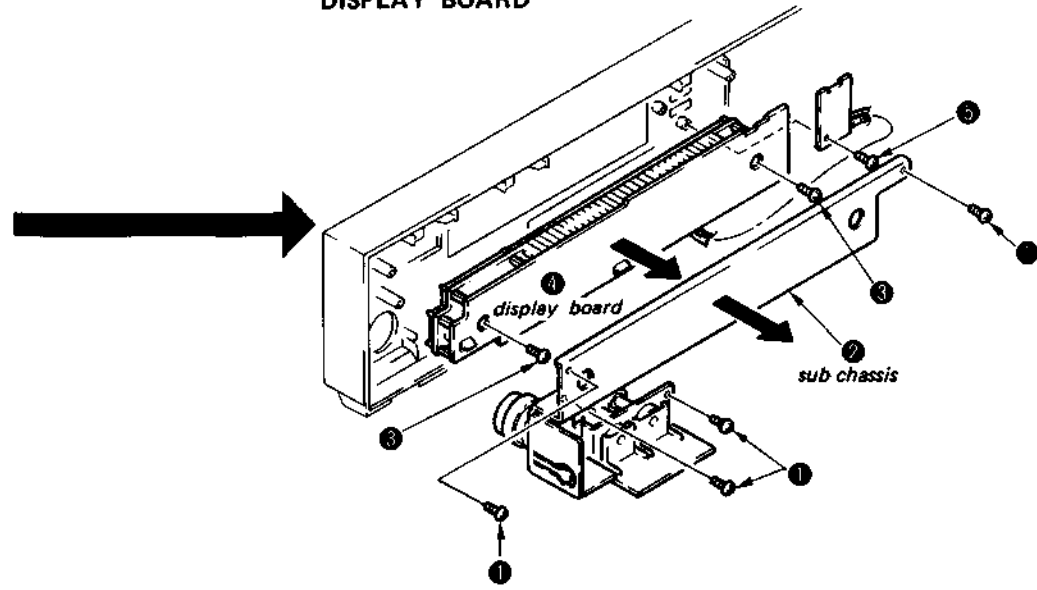

REEL MOTOR

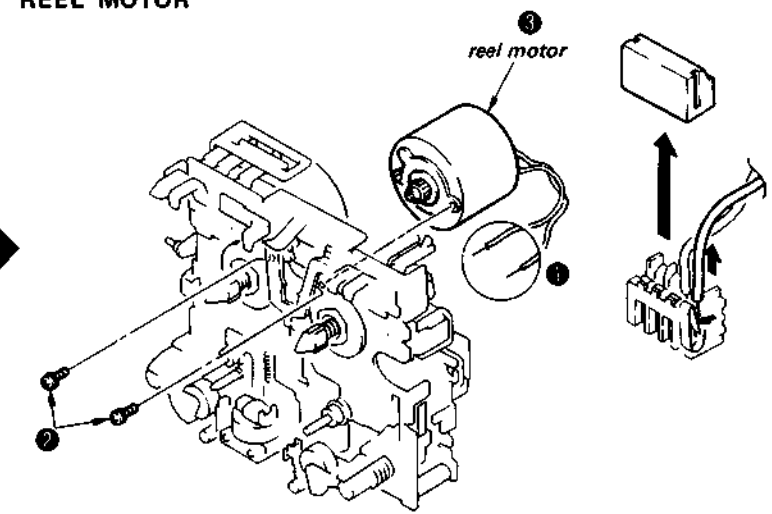

REEL TABLE

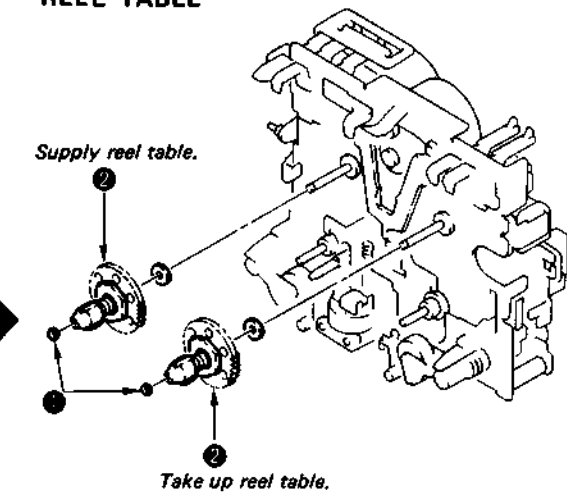

CAPSTAN MOTOR, BELT

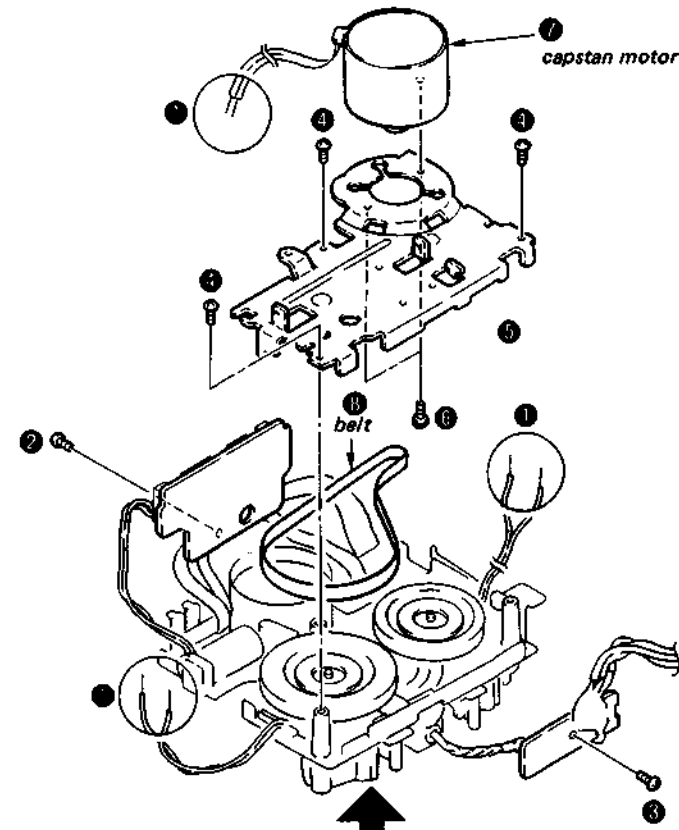

FLYWHEEL

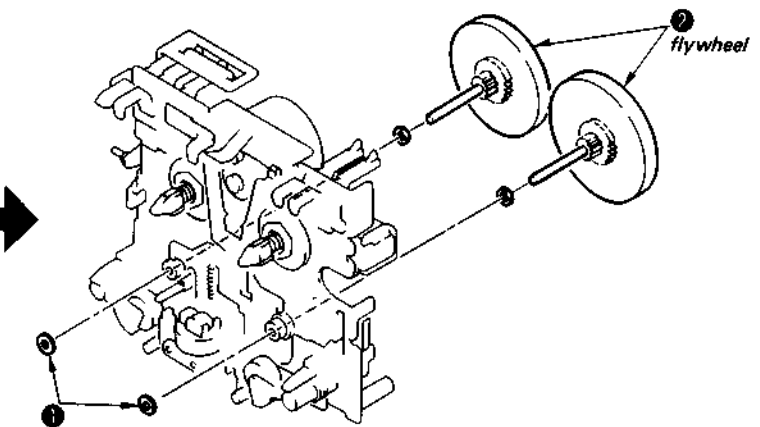

HEAD

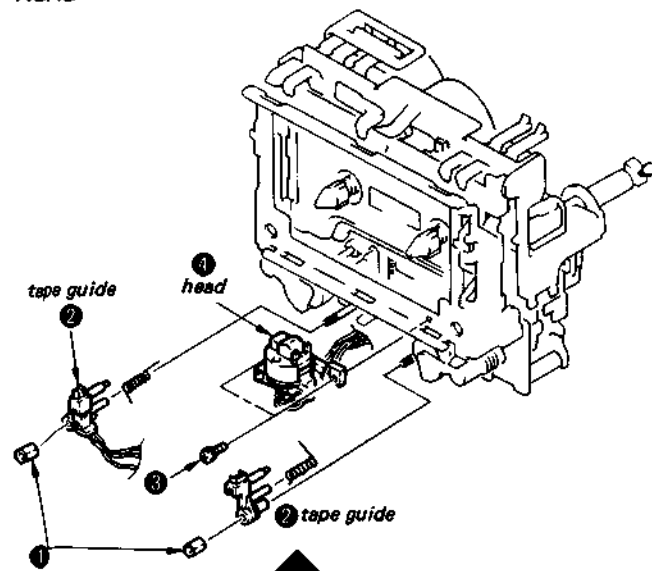

**SECTION 3
ADJUSTMENTS**

3-1. MECHANICAL ADJUSTMENTS

PRECAUTION

1. Clean the following parts with a denatured-alcohol-moistened swab:

record/playback head	pinch roller
erase head	rubber belts
capstan	idler
2. Demagnetize the record/playback head with a head demagnetizer.
3. Do not use a magnetized screwdriver for the adjustments.
4. After the adjustments, apply suitable locking compound to the parts adjusted.
5. The adjustments should be performed with the rated power supply voltage unless otherwise noted.

Torque measurement

Torque	Torque meter	Meter reading
FWD Torque	CQ102C	30 – 70 g·cm (0.42 – 0.97 oz·inch)
REV Torque	CQ102RC	30 – 70 g·cm (0.42 – 0.97 oz·inch)
FF·REW Torque	CQ201B	90 – 160 g·cm (1.3 – 2.2 oz·inch)

3-2. ELECTRICAL ADJUSTMENTS

1. The adjustments in the following sections are to be performed with the mechanism deck in the set.
2. The adjustment should be performed in the order given in this service manual.
3. The adjustments should be performed for both L-CH and R-CH.

- Set the TAPE select switches according to the tape as follows.

Tape	Tape type indicator
CS-17	TYPE I
CS-26	TYPE II
CS-42	TYPE IV

- Switch position
 DOLBY NR OFF
 TIMER OFF
 REC CAL CENTER (center click)
- Standard Record:
 Deliver the standard input signal level to the input jack and set the REC LEVEL control to obtain the standard output signal level.

Standard Input Level

	LINE IN
source impedance	10kΩ
input level	0.25V (-10dB)

Standard output Level

	LINE OUT
load impedance	47kΩ
output level	0.44V (-5dB)

Tape Speed Adjustment

Procedure:

Mode: FWD playback

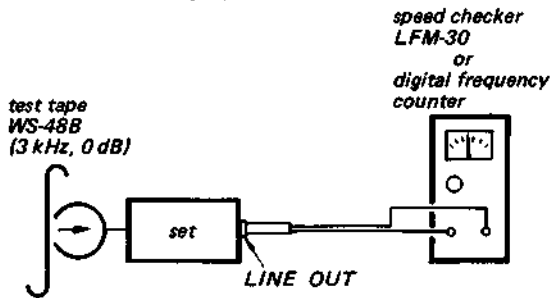

Specification:

Speed checker	Digital frequency counter
-1 - +1%	2,970 - 3,030 Hz

Frequency difference between the beginning and the end of the tape should be within 0.84% (25Hz).

Adjustment Location:

Adjust by using a screwdriver when turning in the direction of clockwise, speed will be fast.

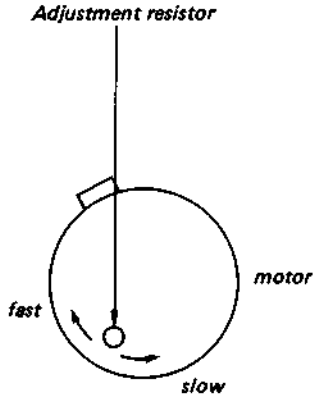

Record/Playback Head Azimuth Adjustment

Procedure: Adjust both NOR and REV.

1. Mode: playback

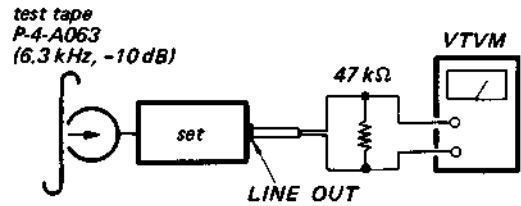

2. Turn the adjustment screw for the maximum output levels. If these levels do not match, turn the adjustment screw until both of output levels match together within 1 dB.

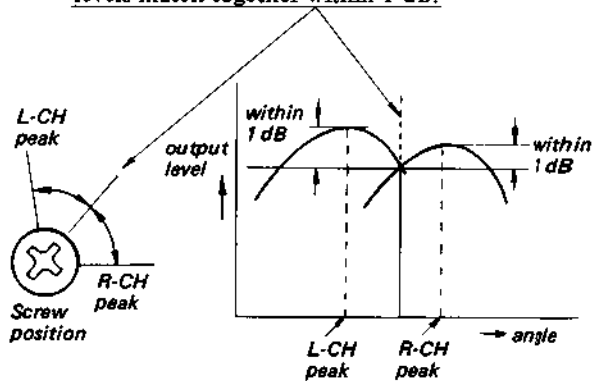

3. Phase Check

Mode: playback

test tape
P-4-A100
(6.3 kHz, -10 dB)

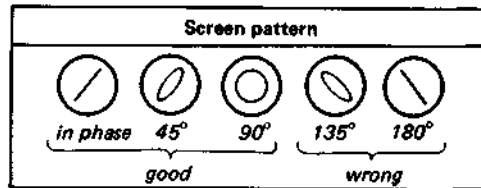
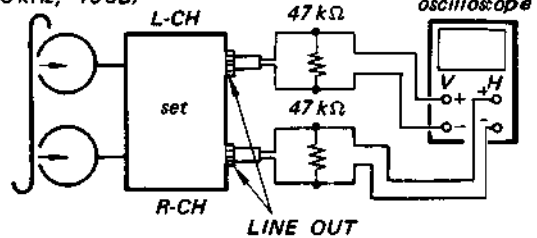

Adjustment Location:

- Record/Playback head -

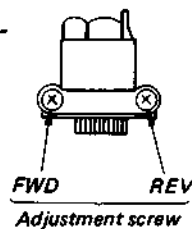

Playback Level adjustment

Procedure:

1. Mode: playback
test tape
P-4-L300
(315 Hz, 0 dB)

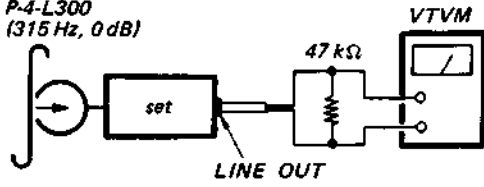

2. Adjust RV101 (L-CH) and RV201 (R-CH) to obtain the specified LINE OUT level.

Specification: LINE OUT level: 0.41 – 0.46 V
(–5.5 to –4.5 dB)

Level difference between channels: less than 0.5 dB

Confirm that the LINE OUT level is not changed when repeating playback and stop modes.

Adjustment Location: AUDIO board

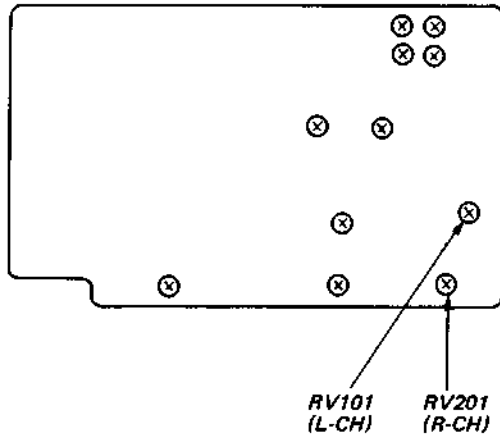

Record Bias Adjustment

Setting:

REC LEVEL control: standard record
(See page 11.)

Procedure:

1. Mode: record

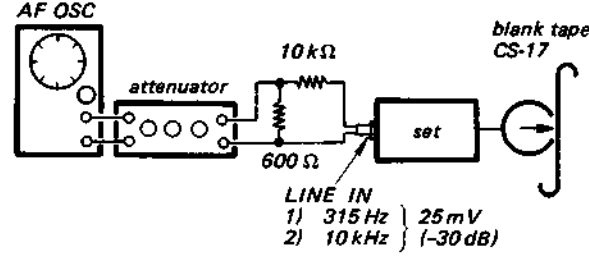

2. Mode: playback

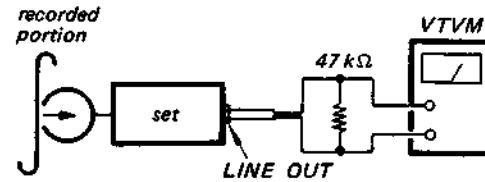

3. Adjust RV104 (L-CH), RV204 (R-CH) so that the LINE OUT level of 10 kHz signal is 0 ± 0.5 dB relative to that of 315 Hz.

Adjustment Location: AUDIO board

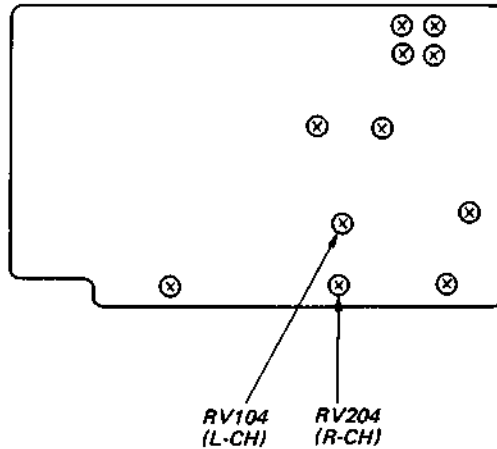

Record Level Adjustment

Setting:

REC LEVEL control: standard record
(See page 11.)

Procedure:

1. Mode: record

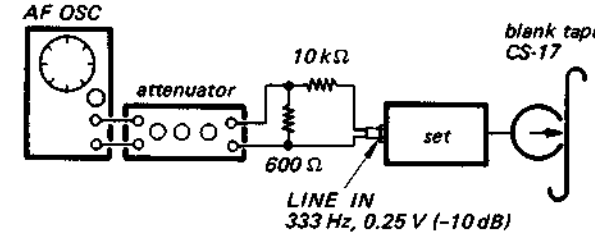

2. Mode: playback

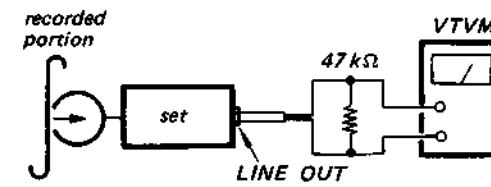

3. Adjust RV103 (L-CH) and RV203 (R-CH) to obtain the specified LINE OUT level.

Specification:

LINE OUT level: 0.41 – 0.46 V
(–5.5 to –4.5 dB)

Adjustment Location: AUDIO board

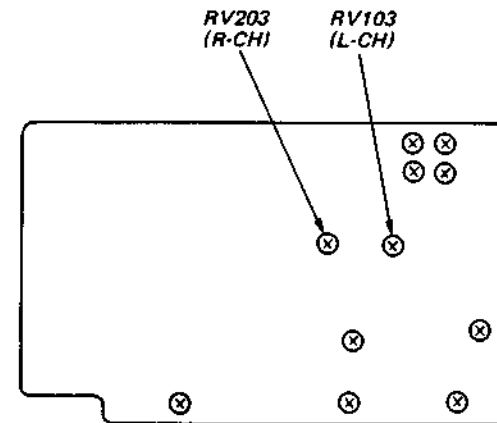

Meter Level adjustment

Procedure:

1. Mode: record

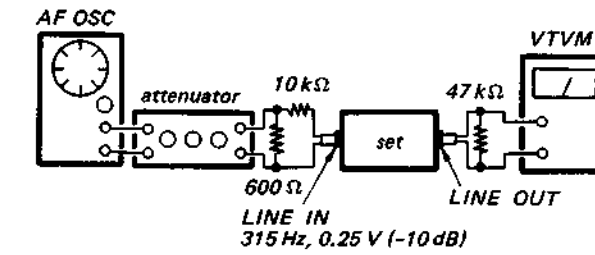

2. Adjust the REC LEVEL (RV301) for –5 dB LINE OUT level.

3. Adjust RV106 (L-CH) and RV206 (R-CH) for the point where meter 0 VU (–4 dB) section segments lights up.

4. Confirm that all the meter segments light up when LINE OUT level is +9 dB.

Adjustment Location: AUDIO board

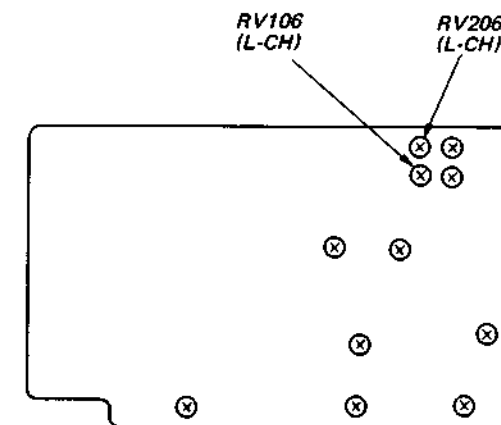

CAL Oscill...

Conditions

- REC CA
- Ground shown i and CA

CAL mo

(C R)

1. Insert abou play (R-CH refer
2. After syste

Record Level Adjustment

Setting:

REC LEVEL control: standard record
(See page 11.)

Procedure:

1. Mode: record

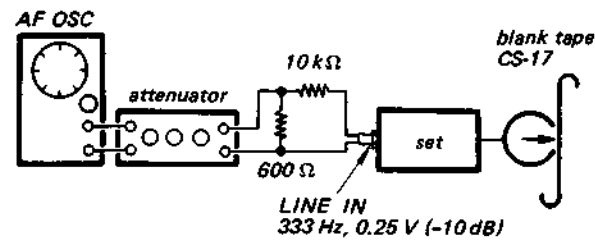

2. Mode: playback

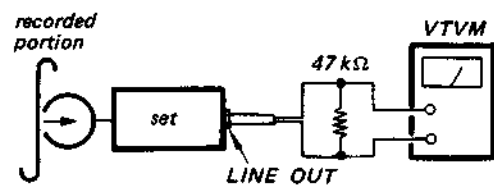

3. Adjust RV103 (L-CH) and RV203 (R-CH) to obtain the specified LINE OUT level.

Specification:

LINE OUT level: 0.41 – 0.46 V
(-5.5 to -4.5 dB)

Adjustment Location: AUDIO board

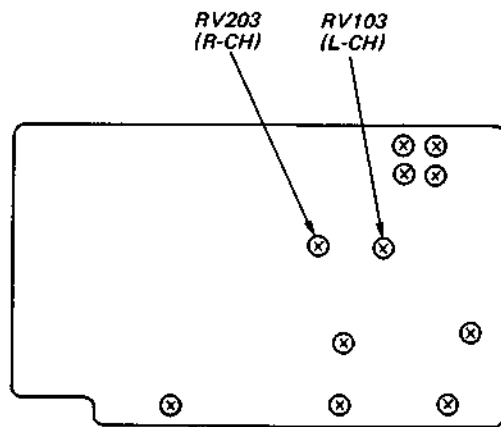

Meter Level adjustment

Procedure:

1. Mode: record

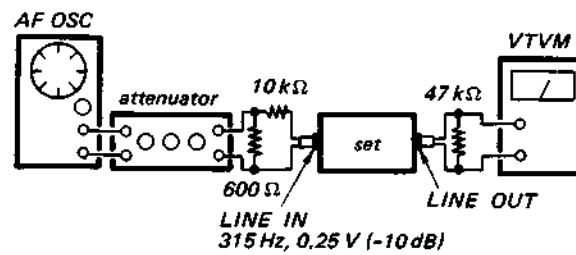

2. Adjust the REC LEVEL (RV301) for -5 dB LINE OUT level.
3. Adjust RV106 (L-CH) and RV206 (R-CH) for the point where meter 0 VU (-4 dB) section segments lights up.
4. Confirm that all the meter segments light up when LINE OUT level is +9 dB.

Adjustment Location: AUDIO board

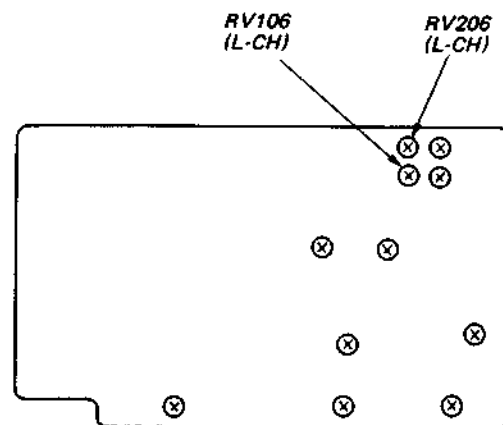

CAL Oscillation Level/CAL Meter Level Adjustment

Conditions:

- REC CAL knob: center (center click)
- Ground system control board TP-1 (CAL mode) as shown in the figure. (Display tube displays CAL, and CAL oscillation state begins.)

CAL mode display

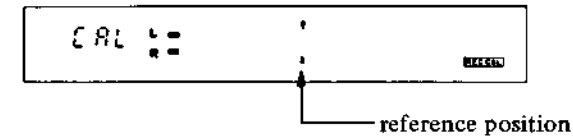

1. Insert CS-15, perform recording operation for about 10 seconds, then rewind the tape and play it back. Adjust RV105 (L-CH) and RV205 (R-CH) so that the segment one above the reference position lights up at this time.
2. After adjustment, remove the connection to system control board TP-3 (CAL mode).

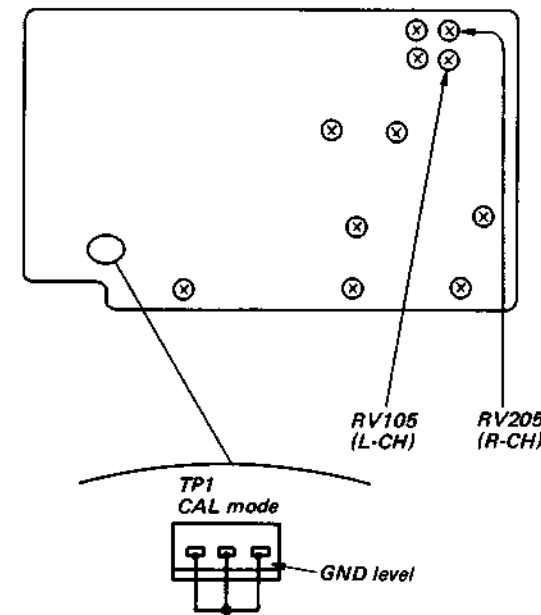

Quick Reverse Sensitivity Adjustment

Conditions:

Direction mode switch: \rightleftarrows

Adjustment Method:

1. Connect a DC voltmeter to system control board TP2.
2. Insert an empty cassette and put into FWD state.
3. Adjust RV501 for 10 V reading on the DC voltmeter.







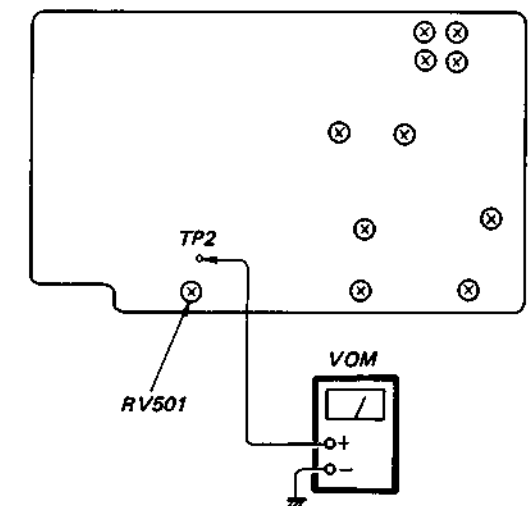

Specification: 10 V \pm 0.5 V

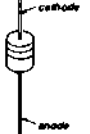
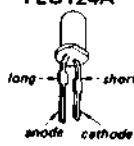
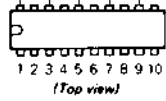
4. Repeat FWD, STOP two or three times and check the voltage again.
5. Confirm that the tape reverses at joint portion of leader tape and magnetic tape.

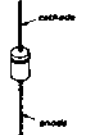
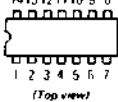
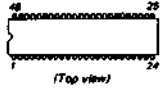
Adjustment Location: AUDIO board

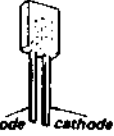
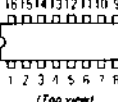
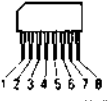
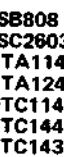
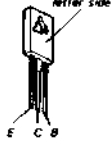

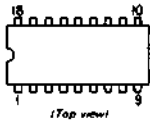
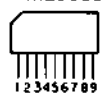
● Semiconductor Lead Layouts

1SS202-1 	GL-3PR7 GL-3HY7 SEL2410E TLG124A 	M50761-3079 20 18 16 14 12 19 17 15 13 11  (Top view)	2SA1409-L 2SB1013 2SC2001 2SC3622A-L 2SD1387 	2SD1585-L 
HZS6A1L HZS7B2L HZS9B3L HZS9C1L HZS12C1L 	TC4069UBP μPD4066C 14 13 12 11 10 9 8  (Top view)	LC6520C-3079  (Top view)	2SB647 	2SD774 
GL-9NG260 	CX10034 TC4019BP 16 15 14 13 12 11 10 9  (Top view)	M5201L M5218L 	2SB808 2SC2603F DTA114ES DTA124ES DTC114ES DTC144ES DTC143TS 	2SB731 2SD809 
HD614042SA87 M5220P μPC4570C  (Top view)	μPC1297CA  (Top view)	NJM2903S 	2SK246-GR2 	2SA1175 

● Semiconductor Location

Ref. No.	Location	Ref. No.	Location	Ref. No.	Location	Ref. No.	Location	Ref. No.	Location	Ref. No.	Location
D101	B-9	D521	B-19	D768	D-24	Q103	F-11	Q317	G-15	Q530	F-19
D201	A-9	D522	D-20	D769	D-24	Q104	D-12	Q318	G-15	Q531	F-19
D301	I-11	D523	C-16	D770	D-24	Q105	E-12	Q319	G-14	Q532	F-19
D302	D-17	D524	C-16	D771	C-31	Q106	F-11	Q320	G-14	Q533	E-19
D303	I-14	D525	E-17	D772	C-23	Q107	F-11	Q501	A-13	Q534	H-16
D305	E-15	D526	E-16	D773	C-23	Q108	E-11	Q502	B-13	Q535	H-16
D306	F-15	D527	E-15	D774	C-23	Q109	B-8	Q503	A-12	Q536	H-16
D307	F-11	D528	E-16	D775	D-24	Q201	C-9	Q504	B-13	Q537	G-17
D308	G-11	D530	C-16	D776	C-25	Q202	H-9	Q505	B-12	Q538	C-15
D310	G-16	D531	D-18	Q203	F-8	Q506	C-13	Q539	D-17	Q540	E-17
D311	F-16	D532	G-17	IC101	B-10	Q204	D-13	Q507	C-13	Q541	E-17
D312	F-28	D533	F-15	IC201	B-10	Q205	E-13	Q508	B-13	Q542	B-19
D501	B-14	D534	B-19	IC301	H-10	Q206	G-14	Q509	H-16	Q543	B-19
D502	B-14	D548	E-19	IC302	E-10	Q207	F-14	Q510	F-16	Q701	C-32
D503	B-14	D549	E-20	IC303	F-13	Q208	E-14	Q511	A-18	Q702	C-32
D504	B-14	D550	B-20	IC304	D-15	Q209	B-8	Q612	A-18	Q703	D-32
D505	B-15	D551	I-7	IC305	H-12	Q301	C-11	Q513	B-24	Q704	D-32
D506	B-15	D552	I-5	IC306	D-9	Q302	H-11	Q514	C-16	Q705	D-32
D507	B-16	D553	H-28	IC307	C-6	Q303	F-10	Q515	B-19	Q706	D-31
D508	A-15	D564	H-28	IC308	D-12	Q304	F-10	Q516	B-19	Q707	D-31
D509	B-15	D555	H-30	IC501	D-16	Q305	D-15	Q518	H-17	Q708	D-31
D510	B-12	D556	H-29	IC502	F-18	Q306	D-14	Q519	E-16	Q709	D-30
D511	C-18	D731	D-24	IC503	G-19	Q307	D-13	Q520	E-17	Q710	D-30
D512	F-17	D732	D-24	IC504	G-16	Q308	F-16	Q521	F-16	Q712	C-24
D513	C-9	D760	C-24	IC505	C-19	Q309	F-16	Q522	F-17	Q713	C-24
D514	C-16	D761	D-23	IC506	E-19	Q310	F-15	Q523	F-17	Q714	C-23
D515	B-16	D762	D-23	IC701	D-28	Q311	F-15	Q525	D-20	Q730	D-24
D516	B-16	D763	D-23	IC703	D-25	Q312	G-11	Q526	E-19	Q1001	I-20
D517	B-16	D764	D-24	IC704	D-24	Q313	G-11	Q527	E-19	Q1003	A-3
D518	B-18	D765	C-23	Q315	H-14	Q528	F-19	Q1002	D-3		
D519	B-16	D766	D-24	Q101	C-11	Q316	G-13	Q529	F-19		
D520	C-16	D767	D-24	Q102	G-9						

4-1. SCHEMATIC DIAGRAM

-Display Section-

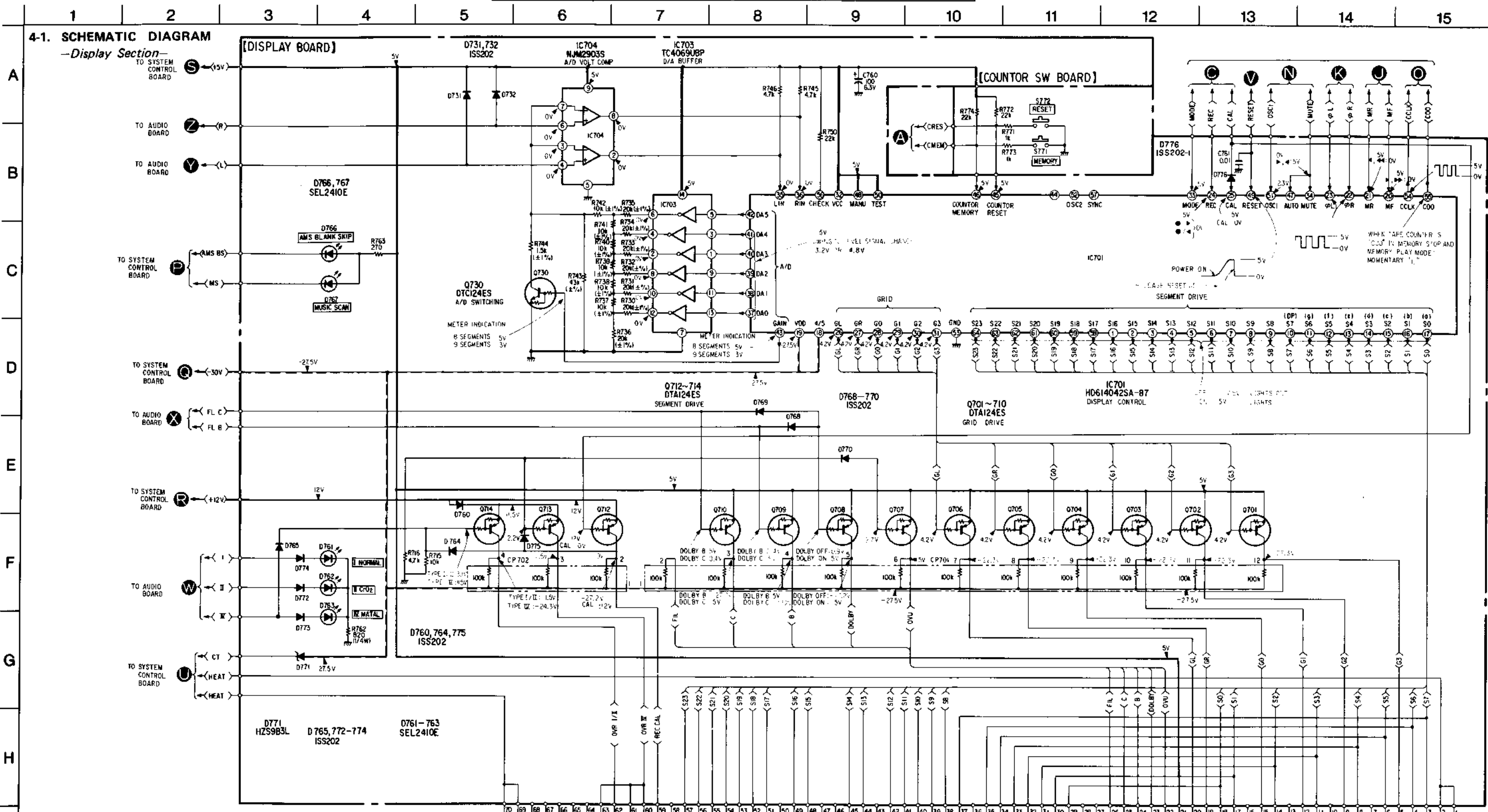

- Note:**
- All capacitors are in μF unless otherwise noted. pF : μpF
 - 50WV or less are not indicated except for electrolytics and tantalums.
 - All resistors are in Ω and $1/8\text{W}$ or less unless otherwise specified.
 - — : B+ bus.
 - - - - : B- bus.
 - Voltages are dc with respect to ground unless otherwise noted.
 - Readings are taken under no-signal conditions with VOM (50k Ω /V).
 - ▶ : FWD ◀ : REW ◀ : REV
 - ▶▶ : FF • : REC

• Switches

Ref. No.	Switch	Position
S771	MEMORY	OFF
S772	RESET	OFF

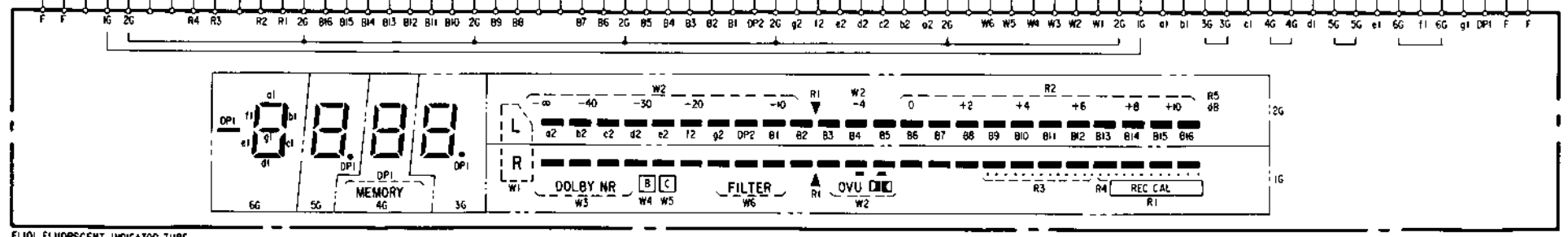

• See page 16 for semiconductor lead layouts and semiconductor location.

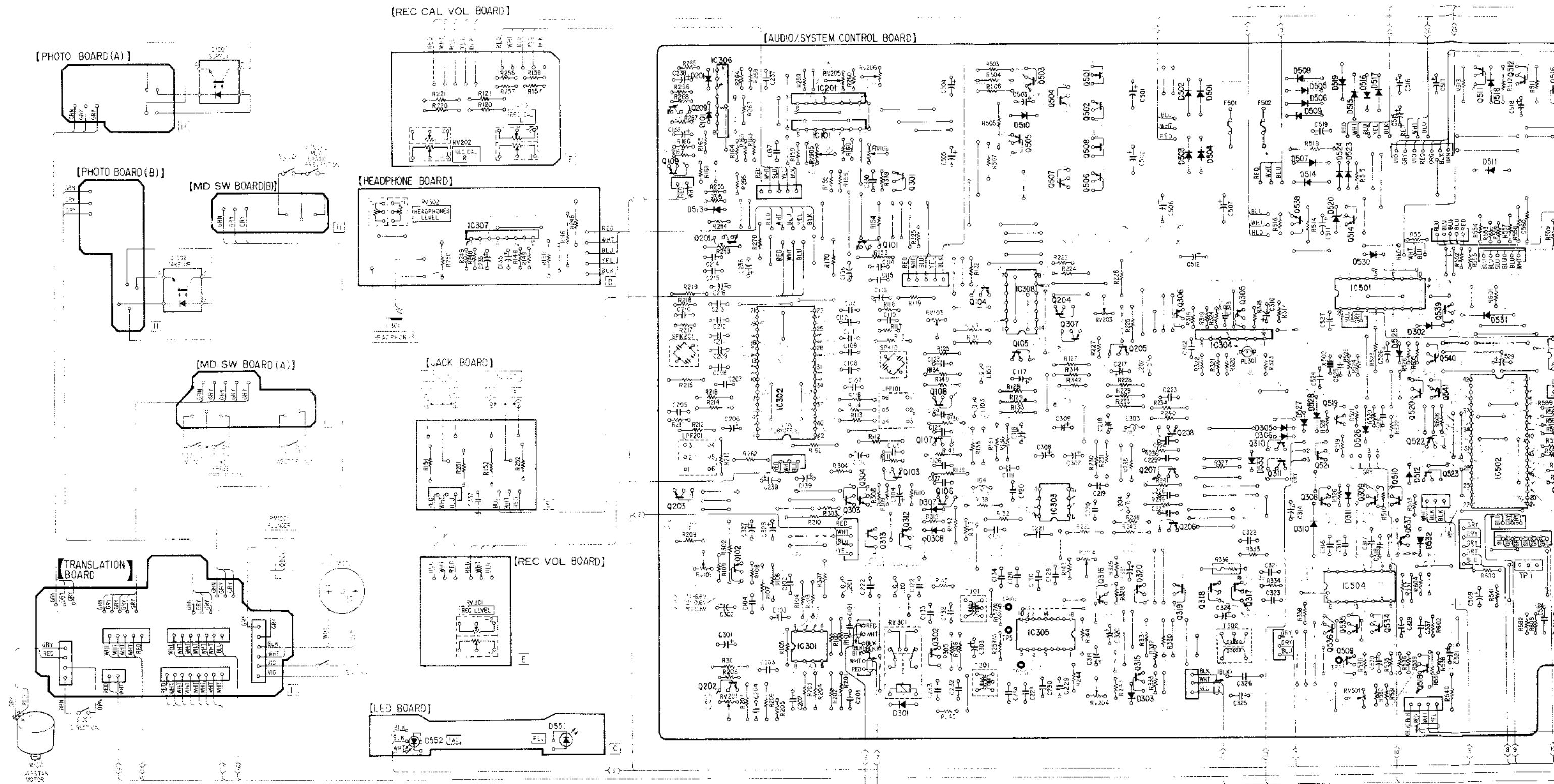

Note:

- Color code of sleeving over the end of the jacket.
- — : parts extracted from the component side.
- — : parts extracted from the conductor side.

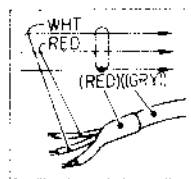

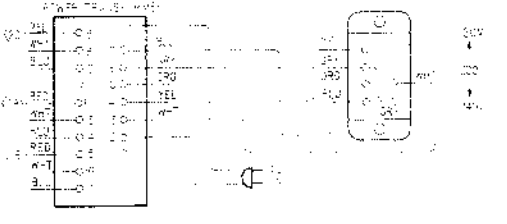
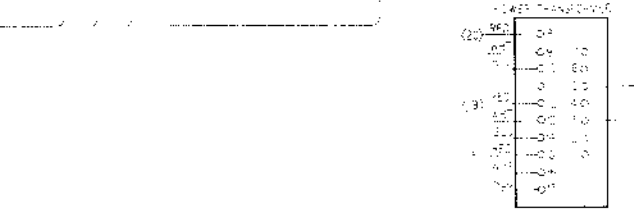
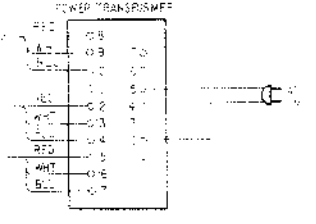
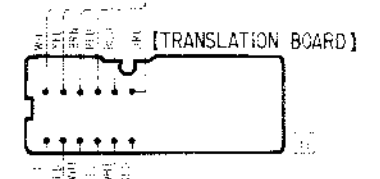
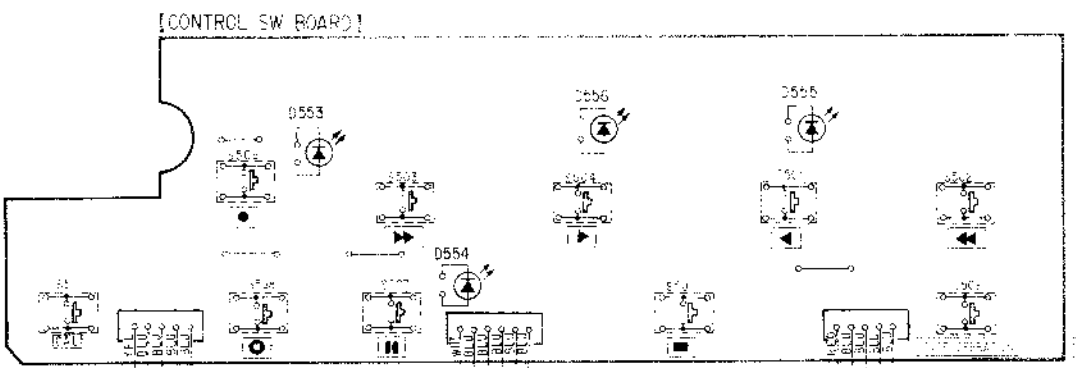
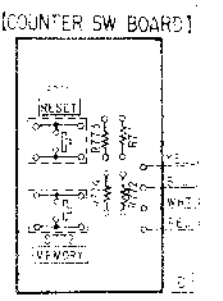
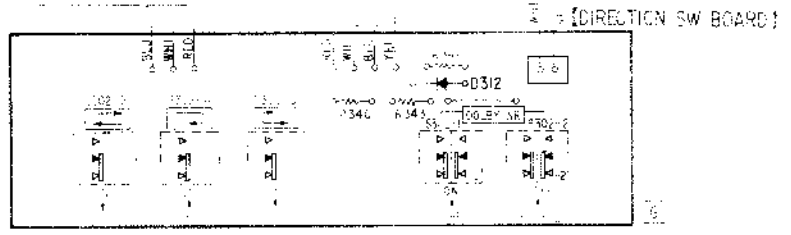
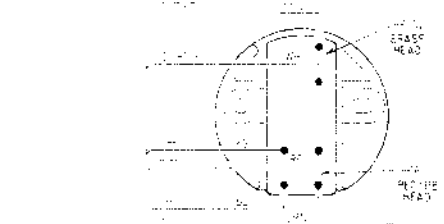
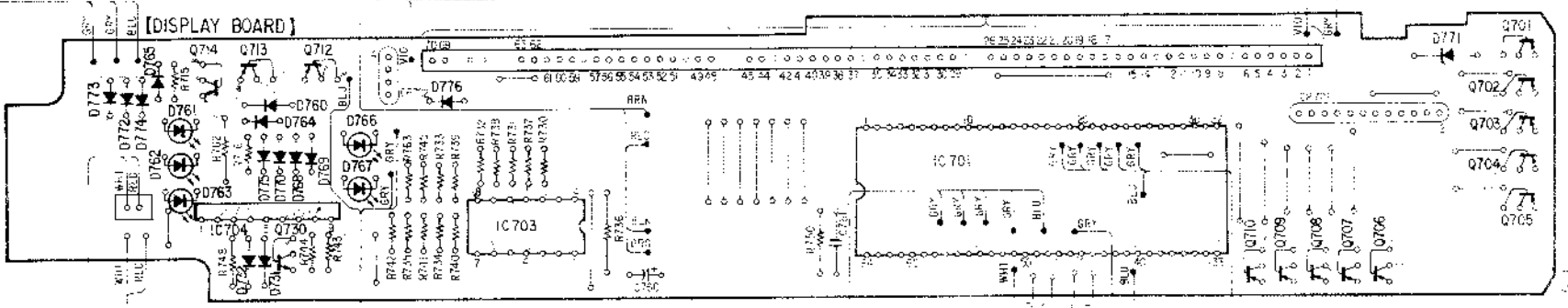
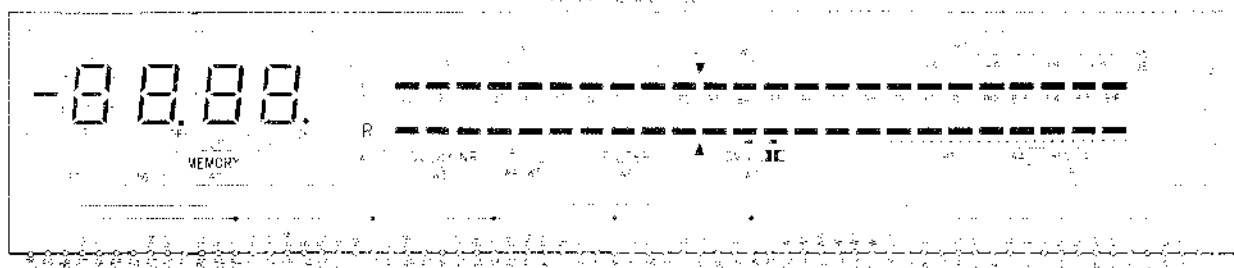
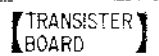
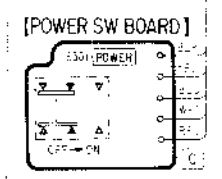
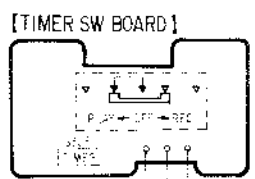
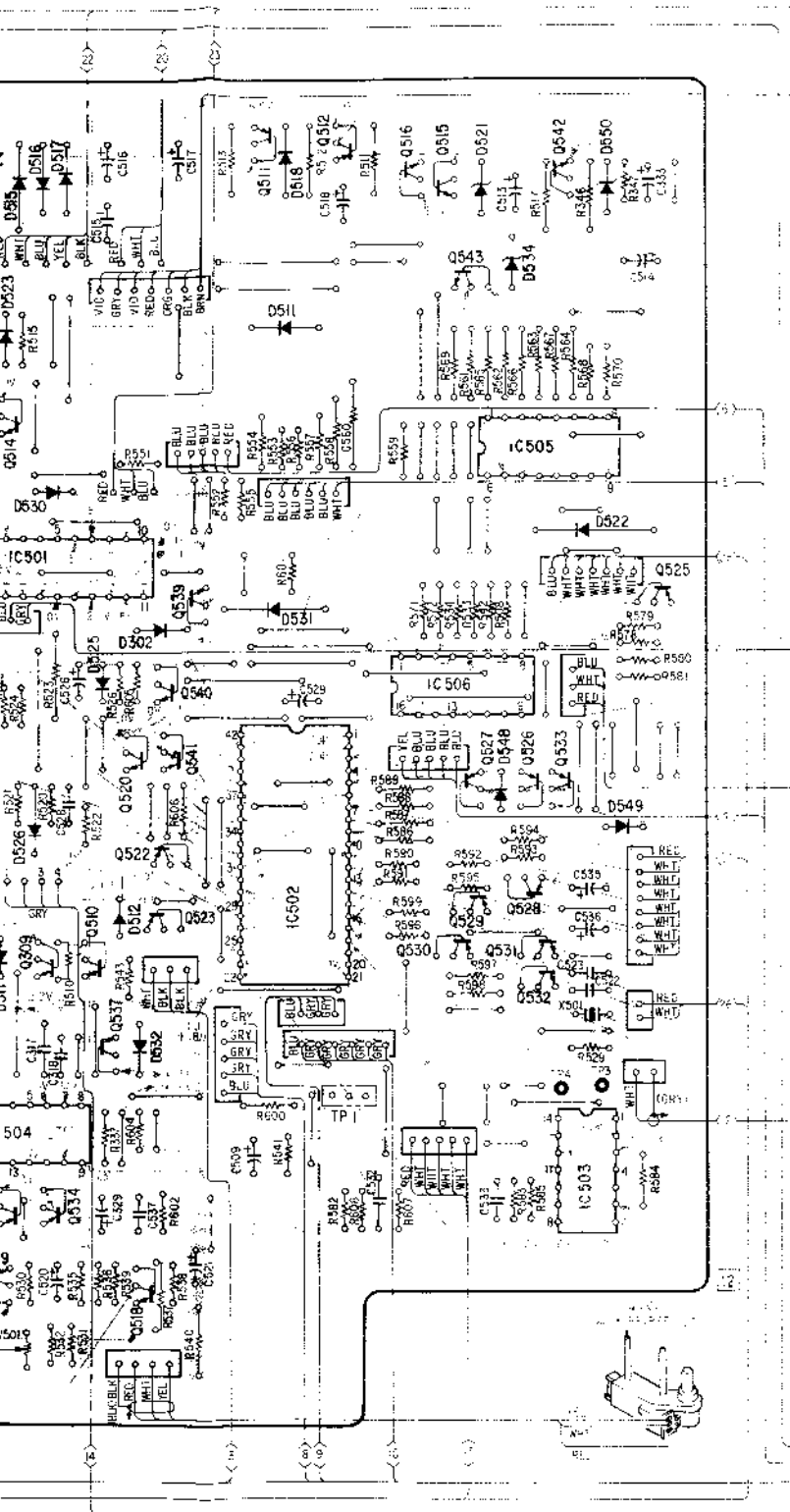

4-3. SCHEMATIC DIAGRAM

-Audio Section-

Note:

- All capacitors are in μF unless otherwise noted. pF : μF 50WV or less are not indicated except for electrolytics and tantalums.
- All resistors are in Ω and $1/8\text{W}$ or less unless otherwise specified.

- : signal path.
- - -: L-CH signal path.
- · - ·: R-CH signal path.
- Components for right channel have same values as for left channel. Reference numbers are coded from 200.
- Δ : internal component.
- \square : fusible resistor.
- --- : B+ bus.
- --- : B- bus.
- \square : adjustment for repair.
- AC voltage readings in the bias oscillator with a VTVM.
- Voltages are dc with respect to ground unless otherwise noted.
- Readings are taken under no-signal conditions with VOM (50k Ω /V).

- Voltage variations may be noted due to normal production tolerances.

- \blacktriangleright : FWD \blacktriangleleft : REW \blacktriangleleft : REV
- $\blacktriangleright\blacktriangleright$: FF \blacksquare : STOP \bullet : REC

Switches

Ref. No.	Switch	Position
S302-1	DOLBY NR	OFF
S302-2	DOLBY NR	B

Note: The components identified by shading and mark Δ are critical for safety. Replace only with part number specified.

Note: Les composants identifiés par une trame et une marque Δ sont critiques pour la sécurité. Ne les remplacer que par une pièce portant le numéro spécifié.

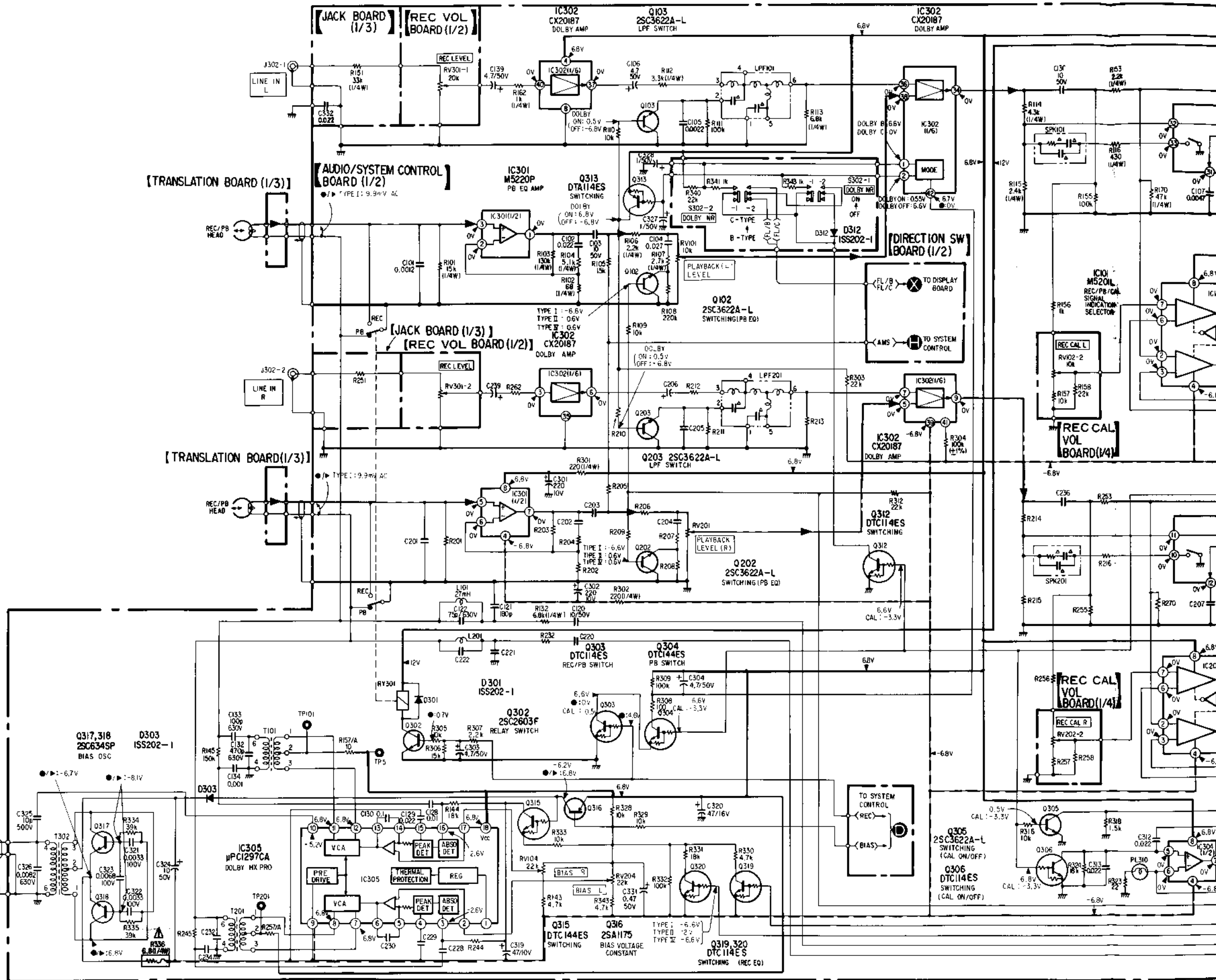

TC-R502/R502ES TC-R502/R502ES

15 16 17 18 19 20 21 22 23 24 25 26 27 28 29 30 31

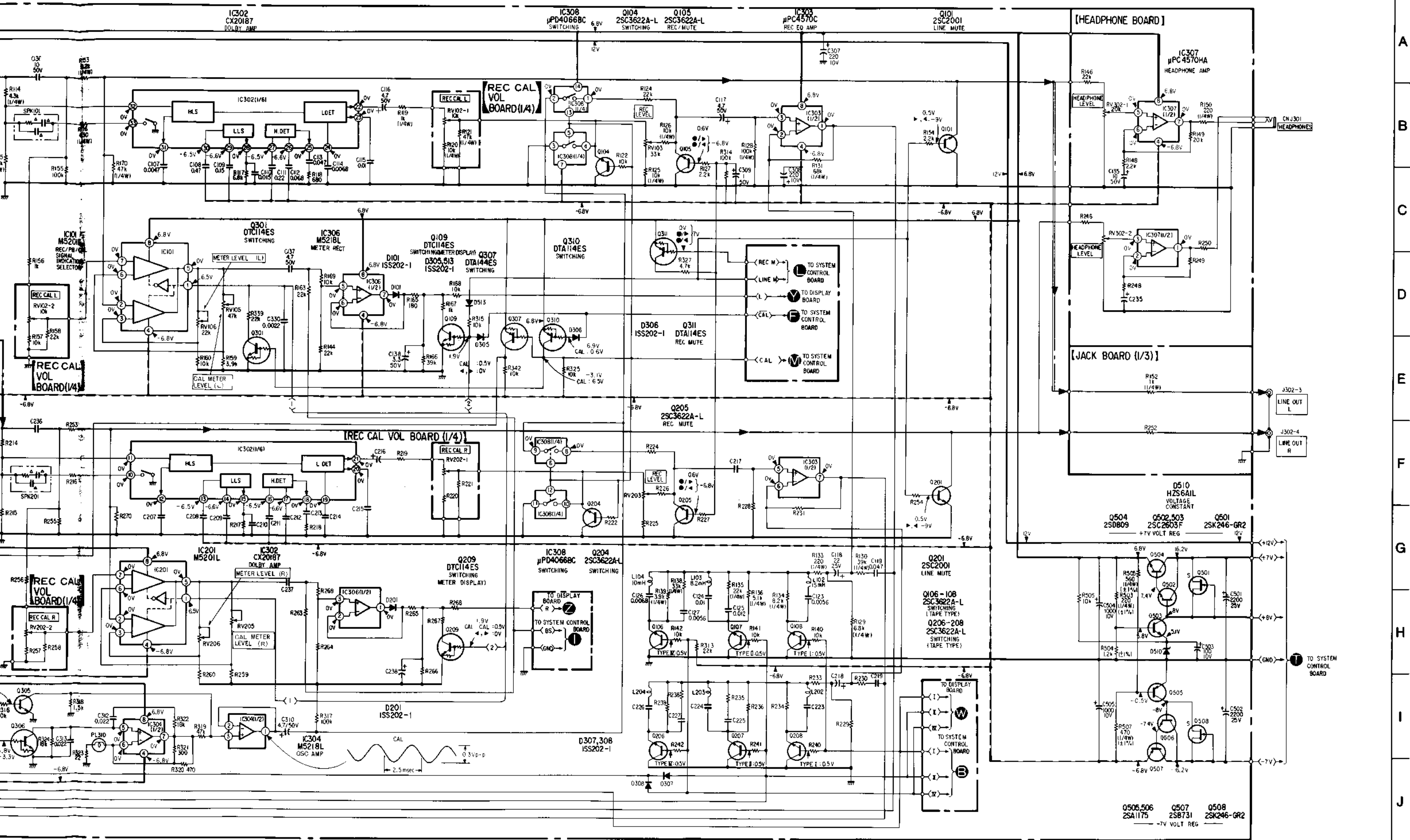

4.4. SCHEMATIC DIAGRAM

-System Control Section-

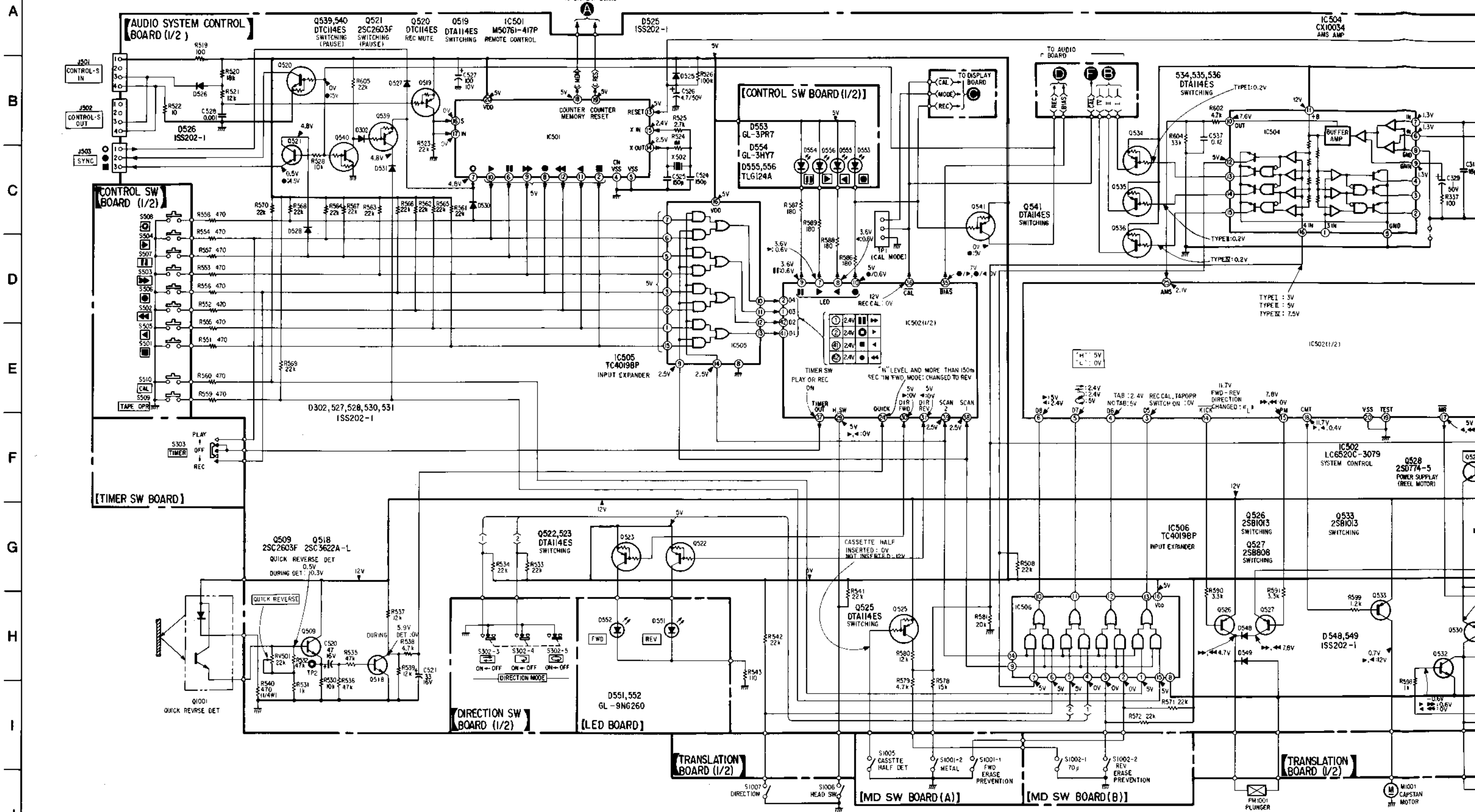

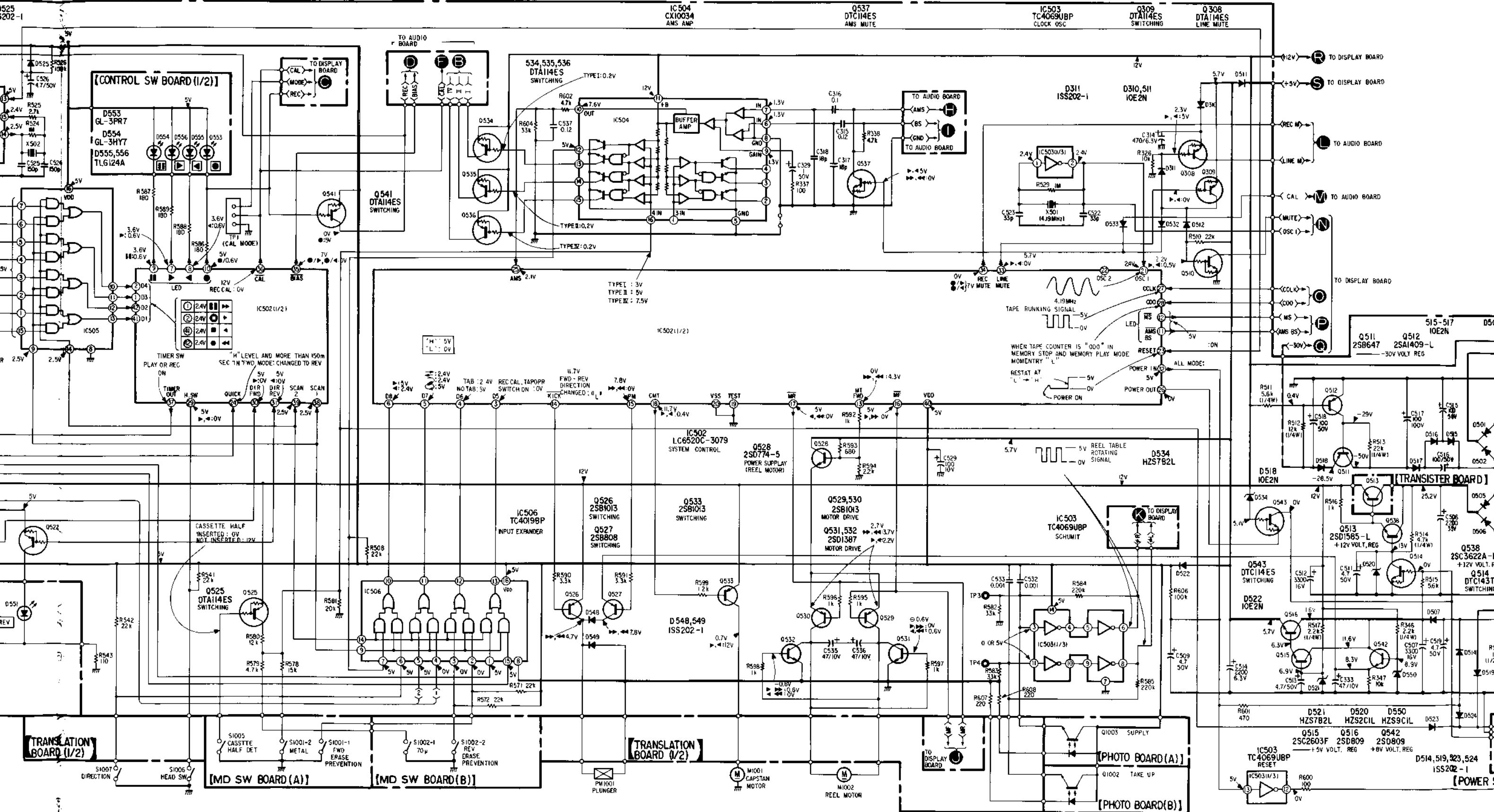

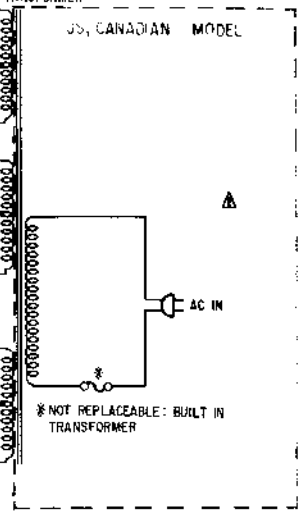
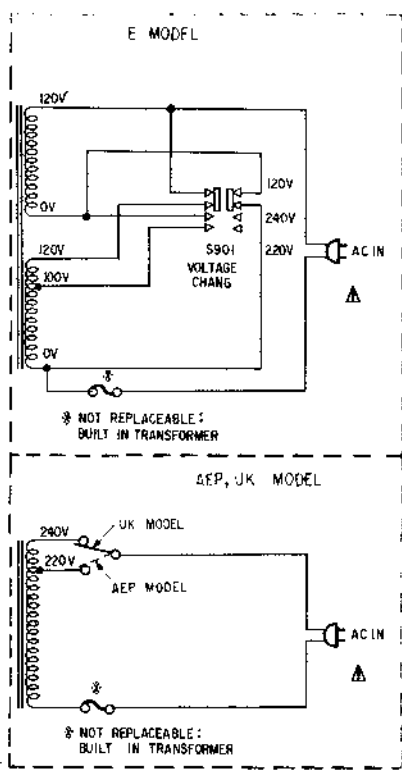
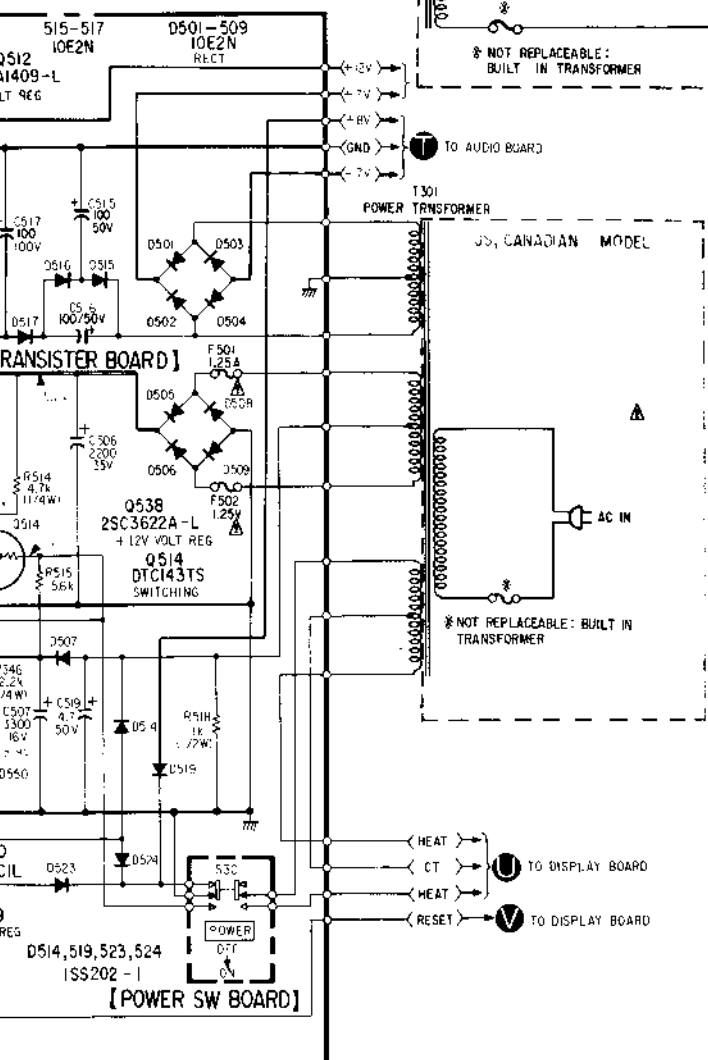

- Note:**
- All capacitors are in μF unless otherwise noted. pF : $\mu\mu\text{F}$
 - 50WV or less are not indicated except for electrolytics and tantalums.
 - All resistors are in Ω and $\frac{1}{4}\text{W}$ or less unless otherwise specified.
 - : nonflammable resistor.
 - : fusible resistor.
 - : B- bus.
 - : B- bus.
 - : adjustment for repair.
 - Voltages are d.c. unless otherwise noted.
 - Resistors are in Ω unless otherwise noted.
 - VOM (50K Ω)
 - ▶ FWD ◀◀ REW ● REC ● REC MUTE
 - ▶▶ FF ■ STOP ◀◀ REV ● PAUSE
 - Switches

Ref. No.	Switch	Position
S301	POWER	OFF
S501	OPERATION	OFF
S510	KEYBOARD SWITCH	OFF
S303	TIMER	OFF
S302-3	DIRECTION MODE	↔
S1001-1	ERASE PREVENTION (FWD)	BE CLAW
S1002-1	70/120 μ	TYPE 1
S1001-2	METAL	TYPE 1
S1002-2	ERASE PREVENTION (REV)	BE CLAW
S1005	CASSETTE HALF DET	NO CLAW
S1006	HEAD SW	FWD
S1007	DIRECTION	FWD

Note: The components identified by shading and mark are critical for safety. Replace only with part number specified.

Note: Les composants identifiés par une trame et une marque sont critiques pour la sécurité. Ne les remplacer que par une pièce portant le numéro spécifié.

SECTION 5
EXPLODED VIEWS AND PARTS LIST

NOTE:

- The mechanical parts with no reference number in the exploded views are not supplied.
- Items marked "*" are not stocked since they are seldom required for routine service. Some delay should be anticipated when ordering these items.
- The construction parts of an assembled part are indicated with a collation number in the remark column.

The components identified by shading and mark **A** are critical for safety. Replace only with part number specified.

Les composants identifiés par une trame et une marque **A** sont critiques pour la sécurité. Ne les remplacer que par une pièce portant le numéro spécifié.

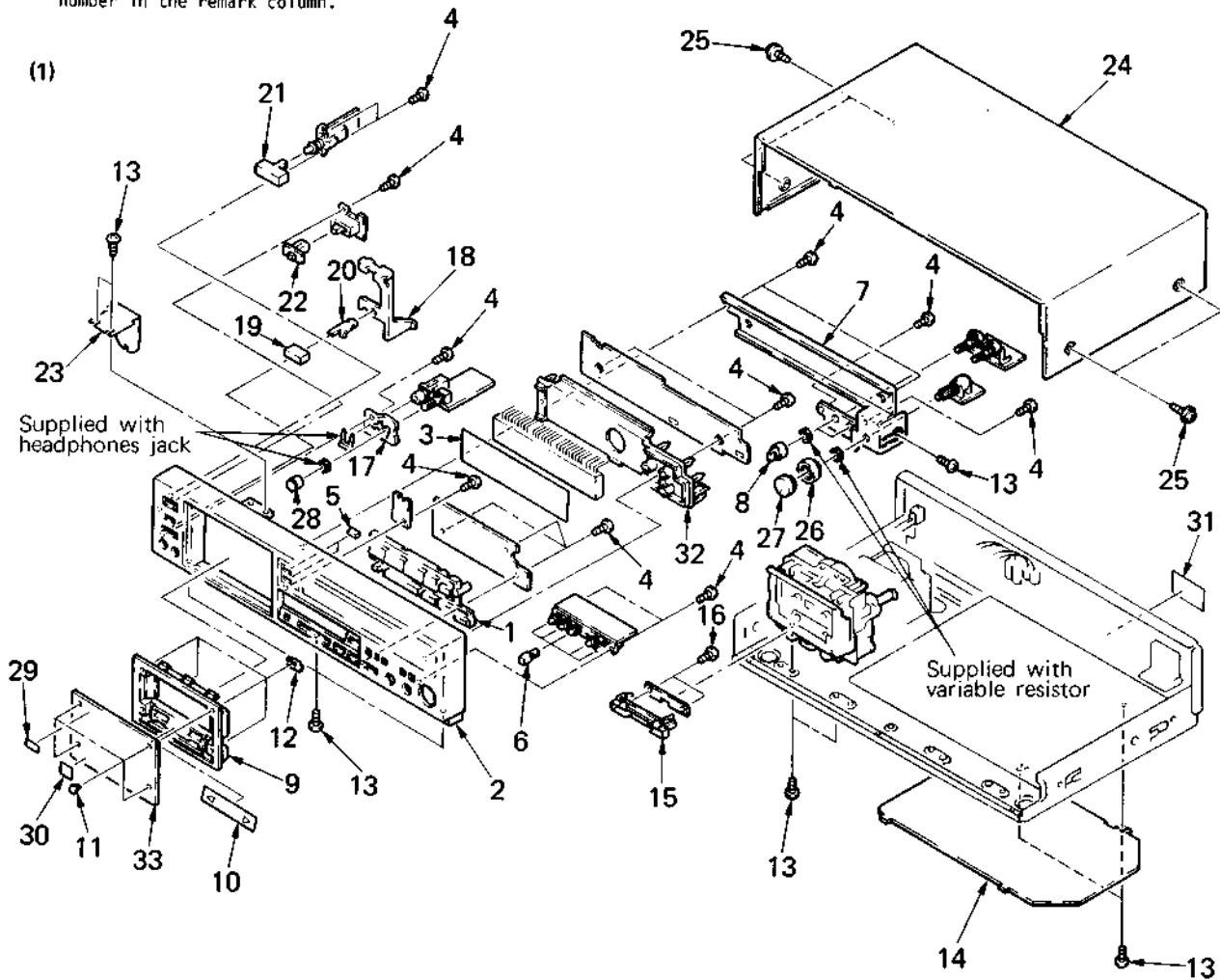

No.	Part No.	Description	Remarks	No.	Part No.	Description	Remarks
1	X-3332-502-1	BUTTON ASSY, CONTROL		17	*3-332-517-01	BRACKET, HEADPHONE	
2	X-3332-504-1	(US,Canadian)...PANEL ASSY, FRONT		18	*3-332-516-01	LEVER, EJECT	
	X-3332-505-1	(AEP,UK,E)...PANEL ASSY, FRONT		19	3-304-419-31	BUTTON, EJECT	
3	*3-332-505-01	FILTER		20	*3-332-515-01	SLIDER, EJECT	
4	7-685-646-71	SCREW +BVTP 3X8 TYPE2 N-S		21	3-332-417-01	KNOB (POWER), PUSH	
5	3-332-502-01	BUTTON, RESET		22	3-307-538-21	KNOB, SWITCH, TIMER	
6	4-855-804-11	KNOB, SQUARE		23	*3-333-616-01	PLATE, SHIELD, REEL MOTOR	
7	*3-332-508-01	CHASSIS (H), SUB		24	3-332-511-01	CASE	
8	3-304-929-11	KNOB, HEADPHONE		25	4-886-821-01	SCREW, M3 CASE	
9	3-332-526-01	LID, CASSETTE		26	3-332-519-01	KNOB (LEFT), REC VOL	
10	3-332-530-11	PLATE, INDICATION, DIRECTION		27	3-332-518-01	KNOB (RIGHT), REC VOL	
11	3-330-003-01	PIN, STOPPER, CASSETTE WINDOW		28	4-902-067-11	KNOB, CONTROL	
12	3-324-813-01	SPRING		29	4-911-673-01	SHEET, CAVER	
13	7-685-752-04	SCREW +BVTT 3X8 (S)		30	3-703-710-41	STICKER, SONY SYMBOL (12)	
14	*3-332-418-01	PLATE, BOTTOM		31	4-302-759-00	LABEL, SERIAL NUMBER	
15	3-332-532-01	HOUSE, LED		32	*3-332-507-01	HOLDER, FL TUBE	
16	7-685-133-14	SCREW +BTP 2.6X6 TYPE2 N-S		33	3-332-514-11	WINDOW, CASSETTE	

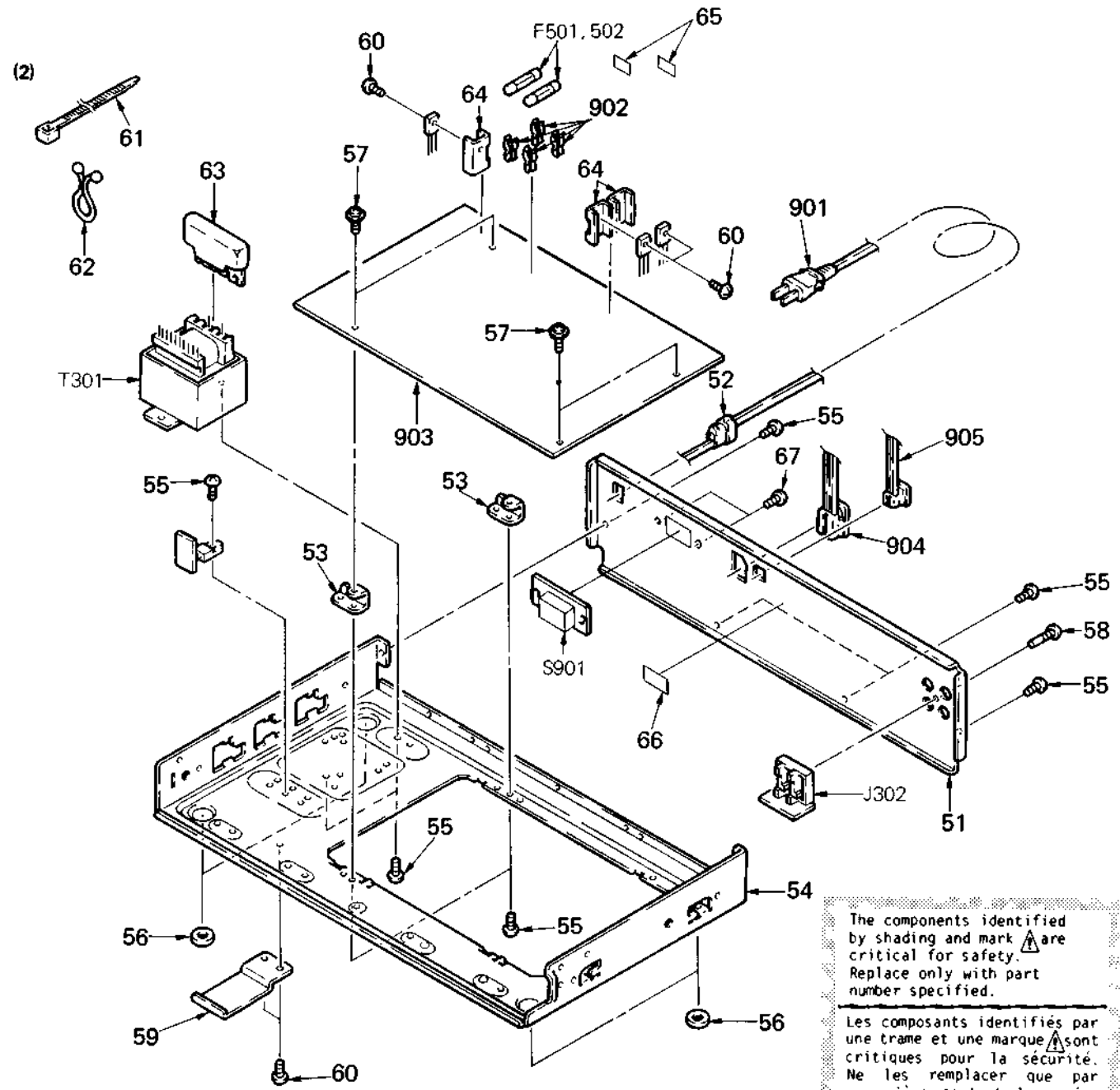

The components identified by shading and mark **A** are critical for safety. Replace only with part number specified.

Les composants identifiés par une trame et une marque **A** sont critiques pour la sécurité. Ne les remplacer que par une pièce portant le numéro spécifié.

No.	Part No.	Description	Remarks	No.	Part No.	Description	Remarks
51	*3-332-509-01	(US,Canadian)...PLATE, JACK		66	3-703-044-26	(US,Canadian)...LABEL, CAUTION	
	3-332-509-21	(E)...PLATE, JACK		67	7-685-133-14	SCREW +BTP 2.6X6 TYPE2 N-S	
	3-332-509-31	(AEP)...PLATE, JACK		901	A 1-534-817-XX	(AEP)...CORD, POWER	
	3-332-509-41	(UK)...PLATE, JACK			A 1-551-188-XX	(E)...CORD, POWER	
52	3-703-244-00	(AEP,UK)...BUSHING, CORD			A 1-551-628-00	(US,Canadian)...CORD, POWER	
	3-703-571-00	(US,Canadian)...BUSHING (S)(4516), CORD			A 1-551-884-00	(UK)...CORD, POWER	
53	*3-332-410-01	BRACKET (2), PC BOARD		902	1-533-162-00	HOLDER, FUSE	
54	*3-332-426-11	CHASSIS		903	*A-2095-583-A	MOUNTED PCB, AUDIO	
55	7-685-752-04	SCREW +BVTT 3X8 (S)		F501	A 1-532-285-11	(AEP,UK,E)...FUSE (1.25A)	
56	3-576-731-00	FELT (H)		F501	A 1-532-741-11	(US,Canadian)...FUSE, GLASS TUBE (1.25A)	
57	3-703-249-01	SCREW, S TIGHT, +PTTMH 3X6		F502	A 1-532-285-11	(AEP,UK,E)...FUSE (1.25A)	
58	3-703-473-00	SCREW, TERMINAL		F502	A 1-532-741-11	(US,Canadian)...FUSE, GLASS TUBE (1.25A)	
59	*3-332-534-01	PLATE, SHIELD, HEAD		J302	1-507-908-11	JACK, PIN 4P (LINE)	
60	7-685-871-01	SCREW +BVTT 3X6 (S)		S901	A 1-570-307-11	(E)...SWITCH, VOLTAGE CHANGE	
61	3-701-748-00	CLAMP		T301	A 1-448-551-11	(US,Canadian)...TRANSFORMER, POWER	
62	3-315-159-01	PURSE LOCK (DIA. 14)		T301	A 1-448-552-11	(AEP,UK)...TRANSFORMER, POWER	
63	*3-332-444-01	COVER, TRANSFORMER SAFETY		T301	A 1-448-553-11	(E)...TRANSFORMER, POWER	
64	*3-312-615-31	HEAT SINK					
65	3-701-948-15	(AEP,UK,E)...LABEL FUSE					

TC-R502/R502ES TC-R502/R502ES

(3)

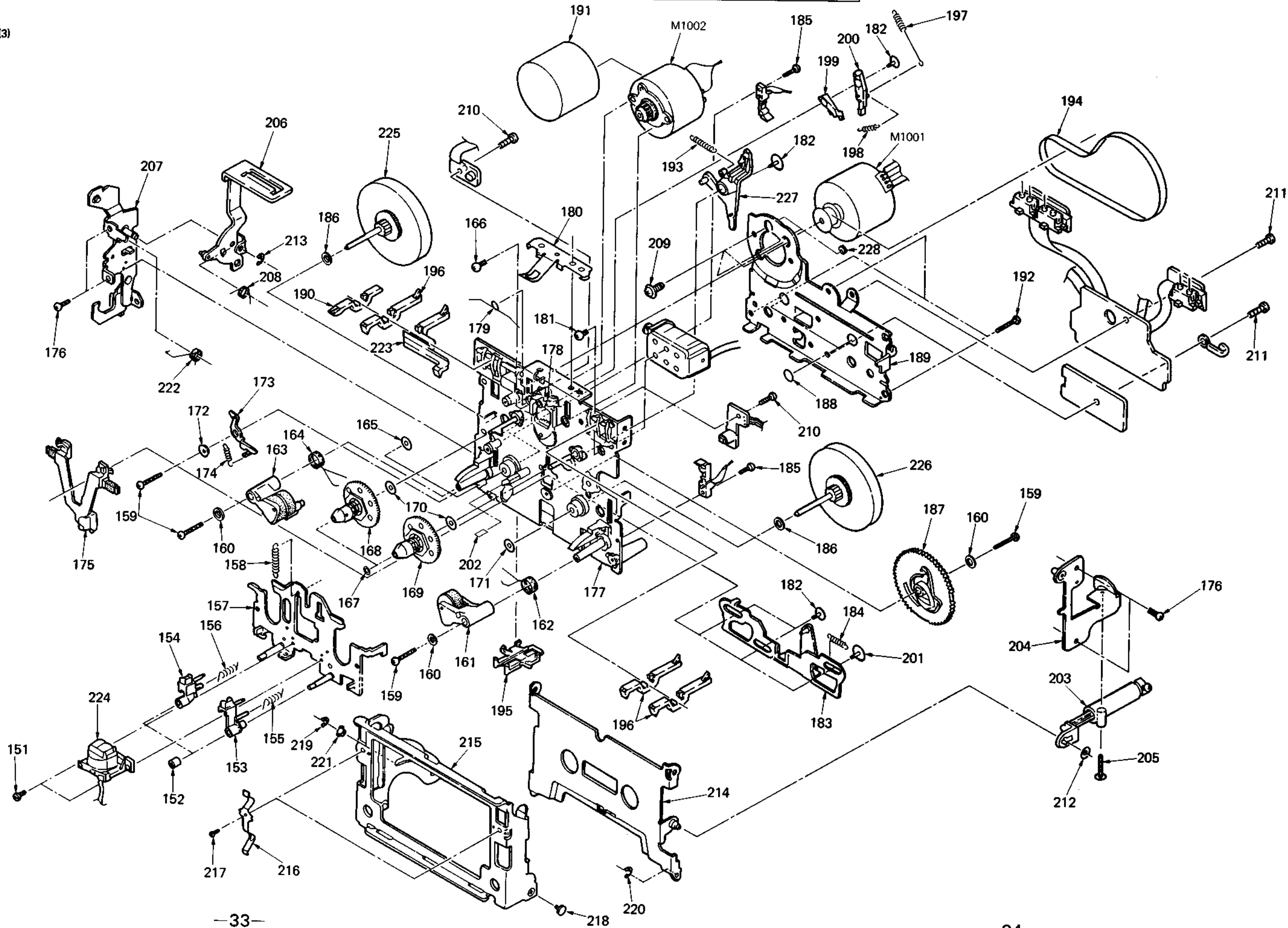

05

- 55
- 58
- 55

Identified
mark are
safety.
with part
ed.

Identifiés par
ne marque sont
r la sécurité.
acer que par
tant le numéro

Remarks

ION
S

TUBE (1/25A)

TUBE (1/25A)

POWER
POWER
POWER

TC-R502/R502ES TC-R502/R502ES

SECTION 6
ELECTRICAL PARTS LIST

NOTE:

Items marked " * " are not stocked since they are seldom required for routine service. Some delay should be anticipated when ordering these items.

If there are two or more same circuits in a set such as a stereophonic machine, only typical circuit parts may be indicated and capacitors and resistors in other same circuits may be omitted.

CAPACITORS:
MF:µF, PF:µµF.

RESISTORS
All resistors are in ohms.
F : nonflammable

COILS
MMH : mH, UH : µH

SEMICONDUCTORS
In each case, U : µ, for example:
UA...: µA..., UPA...: µPA..., UPC...: µPC,
UPD...: µPD...

The components identified by shading and mark  are critical for safety. Replace only with part number specified.

Les composants identifiés par une trame et une marque  sont critiques pour la sécurité. Ne les remplacer que par une pièce portant le numéro spécifié.

No.	Part No.	Description	Remarks
151	3-391-109-01	SCREW, WASHER	
152	3-391-110-01	NUT, ADJUSTMENT	
153	3-391-111-01	GUIDE, TAPE	
154	X-3391-124-1	SENCER ASSY	
155	3-391-112-01	SPRING (RIGHT)	
156	3-391-113-01	SPRING (LEFT)	
157	X-3391-103-1	HEAD ASSY, PLATE	
158	3-391-114-01	SPRING	
159	7-685-107-21	SCREW +P 2X12 TYPE2 SLIT	
160	7-688-001-11	W 2, MIDDLE	
161	X-3391-104-1	PINCH ROLLER ASSY	
162	3-391-115-01	SPRING (RIGHT)	
163	X-3391-105-1	PINCH ROLLER ASSY	
164	3-391-116-01	SPRING (LEFT)	
165	3-391-117-01	SEAL, WASHER OIL	
166	3-391-118-01	SCREW, WASHER	
167	3-701-436-11	WASHER, 1.6	
168	X-3391-106-1	REEL ASSY	
169	X-3391-107-1	REEL ASSY, T.U	
170	3-327-708-31	WASHER	
171	3-391-119-01	SEAL, WASHER OIL	
172	3-391-120-01	CALLOR	
173	3-391-121-01	ARM, EJECT SAFETY	
174	3-391-122-01	SPRING (A)	
175	X-3391-108-1	BRAKE ASSY	
176	7-685-790-04	SCREW +PTT 2.6X4 (S)	
177	X-3391-110-1	CHASSIS ASSY	
178	X-3391-111-1	IDLER ASSY	
179	3-391-124-01	SPRING	
180	3-391-125-01	SPRING	
181	7-628-253-95	SCREW +PS 2.6X4	
182	3-391-126-01	CAP	
183	X-3391-112-1	PLATE ASSY, SLIDE	
184	3-391-127-01	SPRING	
185	7-685-104-14	SCREW +P 2X6 TYPE2 SLIT	
186	3-701-438-11	WASHER, 2.5	
187	3-391-128-01	GEAR (B), CAM	
188	3-391-129-01	SPACER	
189	*3-391-130-01	BRACKET (B), F/W	

No.	Part No.	Description	Remarks
190	3-391-131-01	LEVER, PACK INSPECTION	
191	3-391-132-01	PLATE, SHIELD	
192	7-685-131-19	SCREW +P 2.6X4 TYPE2 NON-SLIT	
193	3-391-133-01	SPRING	
194	3-391-134-01	BELT, MAIN	
195	3-391-137-01	HOLDER, REED	
196	3-391-157-01	LEVER, REC INSPECTION	
197	3-391-139-01	SPRING	
198	3-391-140-01	SPRING (A)	
199	3-391-141-01	ARM (A)	
200	3-391-142-01	ARM (B)	
201	3-391-143-01	CAP	
202	3-391-162-01	REFLECTOR	
203	*X-3391-115-1	DAMPER ASSY	
204	*3-391-144-01	BRACKET (R), DAMPER	
205	7-621-955-75	SCREW, TOTSU PMH 2X12	
206	3-391-163-01	LEVER (B), EJECT	
207	X-3391-126-1	ARM ASSY, EJECT	
208	3-391-146-01	SPRING (B)	
209	3-391-147-01	SCREW, MOTOR FITTING	
210	7-624-105-04	STOP RING 2.3, TYPE -E	
211	7-685-781-04	SCREW +BVT 2X4 (S)	
212	*3-391-148-01	WASHER LOCK	
213	7-685-105-14	SCREW +P 2X8 TYPE2 SLIT	
214	3-391-149-01	PLATE, ORNAMENTAL	
215	3-391-150-01	HOLDER, CASSETTE	
216	3-391-151-01	SPRING	
217	7-685-780-04	SCREW +PTT 2X3 (S)	
218	3-391-152-01	STUD, DOOR	
219	7-624-104-04	STOP RING 2.0, TYPE -E	
220	7-624-102-04	STOP RING 1.5, TYPE -E	
221	3-391-153-01	ROLLER	
222	3-391-154-01	SPRING (A)	
223	3-391-159-01	LEVER, METAL INSPECTION	
224	X-3391-132-1	HEAD ASSY, ROTARY	
225	X-3391-129-1	ASSY F/W	
226	X-3391-133-1	ASSY F/W	
227	X-3391-114-1	ARM ASSY, PLAY	
228	3-391-138-01	MOTOR, CUSHION	

ELECTRICAL PARTS

Ref.No.	Part No.	Description			
901	1-534-817-XX	(AEP).....CORD, POWER			
902	1-551-188-XX	(E).....CORD, POWER			
903	1-551-628-00	(US, Canadian).....CORD, POWER			
904	1-551-884-00	(UK).....CORD, POWER			
902	1-533-162-00	HOLDER, FUSE			
903	*A-2095-583-A	MOUNTED PCB, AUDIO			
904	*1-558-235-11	CORD (WITH CONNECTOR) 4P			
905	*1-558-520-11	CORD (WITH CONNECTOR) 3P			
906	1-618-917-11	PC BOARD, METER			
C101	1-110-196-00	MYLAR	0.0012MF	5%	50V
C102	1-136-157-00	FILM	0.022MF	5%	50V
C103	1-124-186-00	ELECT	10MF	20%	50V
C104	1-136-158-00	FILM	0.027MF	5%	50V
C105	1-162-302-31	CERAMIC	0.0022MF	30%	16V
C106	1-124-927-11	ELECT	4.7MF	20%	50V
C107	1-110-203-00	MYLAR	0.0047MF	5%	50V
C108	1-136-173-00	FILM	0.47MF	5%	50V
C109	1-136-167-00	FILM	0.15MF	5%	50V
C110	1-136-155-00	FILM	0.015MF	5%	50V
C111	1-136-169-00	FILM	0.22MF	5%	50V
C112	1-136-163-00	FILM	0.068MF	5%	50V
C113	1-136-161-00	FILM	0.047MF	5%	50V
C114	1-110-205-00	MYLAR	0.0068MF	5%	50V
C115	1-136-153-00	FILM	0.01MF	5%	50V
C116	1-124-927-11	ELECT	4.7MF	20%	50V
C117	1-124-927-11	ELECT	4.7MF	20%	50V
C118	1-124-481-11	ELECT	22MF	20%	25V
C119	1-136-161-00	FILM	0.047MF	5%	50V
C120	1-124-186-00	ELECT	10MF	20%	50V
C121	1-162-285-31	CERAMIC	180PF	10%	50V
C122	1-136-273-91	FILM	75PF	5%	630V
C123	1-110-204-00	MYLAR	0.0056MF	5%	50V
C124	1-136-153-00	FILM	0.01MF	5%	50V
C125	1-136-154-00	FILM	0.012MF	5%	50V
C126	1-110-204-00	MYLAR	0.0056MF	5%	50V
C127	1-110-204-00	MYLAR	0.0056MF	5%	50V
C128	1-136-153-00	FILM	0.01MF	5%	50V
C129	1-136-157-00	FILM	0.022MF	5%	50V
C130	1-136-165-00	FILM	0.1MF	5%	50V
C132	1-136-478-11	FILM	470PF	5%	630V
C133	1-136-433-11	FILM	100PF	5%	630V
C134	1-110-195-00	MYLAR	0.001MF	5%	50V
C135	1-124-907-00	ELECT	10MF	20%	50V
C136	1-124-186-00	ELECT	10MF	20%	50V
C137	1-124-185-00	ELECT	4.7MF	20%	50V

ELECTRICAL PARTS

Ref.No.	Part No.	Description			
C138	1-124-905-11	ELECT	3.3MF	20%	50V
C139	1-124-927-11	ELECT	4.7MF	20%	50V
C301	1-124-444-00	ELECT	220MF	20%	10V
C302	1-124-444-00	ELECT	220MF	20%	10V
C303	1-124-927-11	ELECT	4.7MF	20%	50V
C304	1-124-927-11	ELECT	4.7MF	20%	50V
C307	1-124-444-00	ELECT	220MF	20%	10V
C308	1-124-444-00	ELECT	220MF	20%	10V
C309	1-124-903-00	ELECT	1MF	20%	50V
C310	1-124-927-11	ELECT	4.7MF	20%	50V
C312	1-136-157-00	FILM	0.022MF	5%	50V
C313	1-136-157-00	FILM	0.022MF	5%	50V
C314	1-124-470-11	ELECT	470MF	20%	6.3V
C315	1-136-166-00	FILM	0.12MF	5%	50V
C316	1-136-165-00	FILM	0.1MF	5%	50V
C317	1-162-205-31	CERAMIC	18PF	5%	50V
C318	1-162-205-31	CERAMIC	18PF	5%	50V
C319	1-124-892-11	ELECT	47MF	20%	10V
C320	1-123-332-00	ELECT	47MF	20%	16V
C321	1-130-285-00	FILM	0.0033MF	5%	100V
C322	1-130-285-00	FILM	0.0033MF	5%	100V
C323	1-130-293-00	FILM	0.0068MF	5%	100V
C324	1-124-907-00	ELECT	10MF	20%	50V
C325	1-107-202-00	MICA	10PF	5%	500V
C326	1-129-713-00	FILM	0.0082MF	10%	630V
C327	1-124-903-00	ELECT	1MF	20%	50V
C328	1-124-903-00	ELECT	1MF	20%	50V
C329	1-124-903-00	ELECT	1MF	20%	50V
C330	1-162-302-31	CERAMIC	0.0022MF	30%	16V
C331	1-124-902-00	ELECT	0.47MF	20%	50V
C332	1-161-494-00	CERAMIC	0.022MF	30%	25V
C333	1-124-892-11	ELECT	47MF	20%	10V
C501	1-124-563-11	ELECT	2200MF	20%	25V
C502	1-124-563-11	ELECT	2200MF	20%	25V
C503	1-124-443-00	ELECT	100MF	20%	10V
C504	1-124-473-11	ELECT	1000MF	20%	10V
C505	1-124-473-11	ELECT	1000MF	20%	10V
C506	1-124-618-11	ELECT	2200MF	20%	35V
C507	1-124-898-11	ELECT	4700MF	20%	16V
C509	1-124-927-11	ELECT	4.7MF	20%	50V
C511	1-124-927-11	ELECT	4.7MF	20%	50V
C512	1-124-897-11	ELECT	3300MF	20%	16V
C513	1-124-927-11	ELECT	4.7MF	20%	50V
C514	1-124-888-11	ELECT	2200MF	20%	6.3V
C515	1-124-122-11	ELECT	100MF	20%	50V

TC-R502/R502ES TC-R502/R502ES

ELECTRICAL PARTS

Ref.No.	Part No.	Description			
C516	1-124-122-11	ELECT	100MF	20%	50V
C517	1-124-932-11	ELECT	100MF	20%	100V
C518	1-124-122-11	ELECT	100MF	20%	50V
C519	1-124-927-11	ELECT	4.7MF	20%	50V
C520	1-123-332-00	ELECT	47MF	20%	16V
C521	1-124-896-00	ELECT	33MF	20%	16V
C522	1-162-211-31	CERAMIC	33PF	5%	50V
C523	1-162-211-31	CERAMIC	33PF	5%	50V
C524	1-162-284-31	CERAMIC	150PF	10%	50V
C525	1-162-284-31	CERAMIC	150PF	10%	50V
C526	1-124-927-11	ELECT	4.7MF	20%	50V
C527	1-124-443-00	ELECT	100MF	20%	10V
C528	1-162-294-31	CERAMIC	0.001MF	10%	50V
C529	1-124-443-00	ELECT	100MF	20%	10V
C532	1-162-294-31	CERAMIC	0.001MF	10%	50V
C533	1-162-294-31	CERAMIC	0.001MF	10%	50V
C535	1-124-892-11	ELECT	47MF	20%	10V
C536	1-124-892-11	ELECT	47MF	20%	10V
C537	1-136-166-00	FILM	0.12MF	5%	50V
C760	1-123-661-00	ELECT	100MF	20%	6.3V
C761	1-162-306-31	CERAMIC	0.01MF	30%	16V
CNP301*	1-564-509-11	PLUG, CONNECTOR	6P		
CNP302*	1-564-506-11	PLUG, CONNECTOR	3P		
CNP303*	1-564-508-11	PLUG, CONNECTOR	5P		
CNP304*	1-564-506-11	PLUG, CONNECTOR	3P		
CNP305*	1-564-506-11	PLUG, CONNECTOR	3P		
CNP307*	1-564-508-11	PLUG, CONNECTOR	5P		
CNP308*	1-564-507-21	PLUG, CONNECTOR	4P		
CNP505*	1-564-507-11	PLUG, CONNECTOR	4P		
CNP507*	1-564-506-11	PLUG, CONNECTOR	3P		
CNP509*	1-564-339-00	PIN, CONNECTOR	5P		
CNP510*	1-564-340-00	PIN, CONNECTOR	6P		
CNP511*	1-564-339-00	PIN, CONNECTOR	5P		
CNP512*	1-564-506-11	PLUG, CONNECTOR	3P		
CNP701*	1-564-510-11	PLUG, CONNECTOR	7P		
CNP702*	1-564-505-11	PLUG, CONNECTOR	2P		
CNP703*	1-564-506-11	PLUG, CONNECTOR	3P		
CNP704*	1-564-508-11	PLUG, CONNECTOR	5P		
CNP705*	1-564-509-11	PLUG, CONNECTOR	6P		
CNP706*	1-564-505-31	PLUG, CONNECTOR	2P		
CNP708*	1-564-506-11	PLUG, CONNECTOR	3P		
CNP709*	1-564-505-41	PLUG, CONNECTOR	2P		
CP701	1-232-239-00	COMPOSITION CIRCUIT BLOCK			
D101	8-719-107-94	DIODE	1SS202-1		
D201	8-719-107-94	DIODE	1SS202-1		
D301	8-719-107-94	DIODE	1SS202-1		
D302	8-719-107-94	DIODE	1SS202-1		
D303	8-719-107-94	DIODE	1SS202-1		
D305	8-719-107-94	DIODE	1SS202-1		
D306	8-719-107-94	DIODE	1SS202-1		
D307	8-719-107-94	DIODE	1SS202-1		
D308	8-719-107-94	DIODE	1SS202-1		
D310	8-719-200-77	DIODE	10E2N		
D311	8-719-107-94	DIODE	1SS202-1		
D312	8-719-107-94	DIODE	1SS202-1		
D501	8-719-200-77	DIODE	10E2N		
D502	8-719-200-77	DIODE	10E2N		
D503	8-719-200-77	DIODE	10E2N		

ELECTRICAL PARTS

Ref.No.	Part No.	Description
D504	8-719-200-77	DIODE 10E2N
D505	8-719-200-77	DIODE 10E2N
D506	8-719-200-77	DIODE 10E2N
D507	8-719-200-77	DIODE 10E2N
D508	8-719-200-77	DIODE 10E2N
D509	8-719-200-77	DIODE 10E2N
D510	8-719-933-33	DIODE HZS6ALL
D511	8-719-200-77	DIODE 10E2N
D512	8-719-107-94	DIODE 1SS202-1
D513	8-719-107-94	DIODE 1SS202-1
D514	8-719-107-94	DIODE 1SS202-1
D515	8-719-200-77	DIODE 10E2N
D516	8-719-200-77	DIODE 10E2N
D517	8-719-200-77	DIODE 10E2N
D518	8-719-200-77	DIODE 10E2N
D519	8-719-107-94	DIODE 1SS202-1
D520	8-719-933-79	DIODE HZS12C1L
D521	8-719-933-47	DIODE HZS7B2L
D522	8-719-200-77	DIODE 10E2N
D523	8-719-107-94	DIODE 1SS202-1
D524	8-719-107-94	DIODE 1SS202-1
D525	8-719-107-94	DIODE 1SS202-1
D526	8-719-107-94	DIODE 1SS202-1
D527	8-719-107-94	DIODE 1SS202-1
D528	8-719-107-94	DIODE 1SS202-1
D530	8-719-107-94	DIODE 1SS202-1
D531	8-719-107-94	DIODE 1SS202-1
D532	8-719-107-94	DIODE 1SS202-1
D533	8-719-107-94	DIODE 1SS202-1
D534	8-719-933-47	DIODE HZS7B2L
D548	8-719-107-94	DIODE 1SS202-1
D549	8-719-107-94	DIODE 1SS202-1
D550	8-719-933-47	DIODE HZS9C1L
D551	8-719-919-20	DIODE GL-9NG260
D552	8-719-919-20	DIODE GL-9NG260
D553	8-719-933-27	DIODE GL-3PR7
D554	8-719-919-00	DIODE GL-3HY7
D555	8-719-812-43	DIODE TLG124A
D556	8-719-812-43	DIODE TLG124A
D731	8-719-107-94	DIODE 1SS202-1
D732	8-719-107-94	DIODE 1SS202-1
D760	8-719-107-94	DIODE 1SS202-1
D761	8-719-301-43	DIODE SEL2410E
D762	8-719-301-43	DIODE SEL2410E
D763	8-719-301-43	DIODE SEL2410E
D764	8-719-107-94	DIODE 1SS202-1
D765	8-719-107-94	DIODE 1SS202-1
D766	8-719-301-43	DIODE SEL2410E
D767	8-719-301-43	DIODE SEL2410E
D768	8-719-107-94	DIODE 1SS202-1
D769	8-719-107-94	DIODE 1SS202-1
D770	8-719-107-94	DIODE 1SS202-1
D771	8-719-933-58	DIODE HZS9B3L
D772	8-719-107-94	DIODE 1SS202-1
D773	8-719-107-94	DIODE 1SS202-1
D774	8-719-107-94	DIODE 1SS202-1
D775	8-719-107-94	DIODE 1SS202-1
D776	8-719-107-94	DIODE 1SS202-1

ELECTRICAL PARTS

Ref.No.	Part No.	Description
F501	1-532-285-11	(AEP, UK, E) FUSE (1.25A)
F501	1-532-741-11	(US, Canada) FUSE, GLASS TUBE (1.25A)
F502	1-532-285-11	(AEP, UK, E) FUSE (1.25A)
F502	1-532-741-11	(US, Canada) FUSE, GLASS TUBE (1.25A)
FL101	1-519-340-11	INDICATOR TUBE, FLUORESCENT
IC101	8-759-602-48	IC M5201L
IC201	8-759-602-48	IC M5201L
IC301	8-759-602-01	IC M5220P
IC302	8-752-018-70	IC CX20187
IC303	8-759-106-41	IC UPC4570C
IC304	8-759-600-02	IC M5218L
IC305	8-759-106-56	IC UPC1297CA
IC306	8-759-600-02	IC M5218L
IC307	8-759-106-61	IC UPC4570HA
IC308	8-759-240-66	IC TC4066BP
IC501	8-759-602-47	IC M50761-417P
IC502	8-759-802-56	IC LC6520C-3079
IC503	8-759-240-69	IC TC4069UBP
IC504	8-759-700-46	IC CX10034
IC505	8-759-240-19	IC TC4019BP
IC506	8-759-240-19	IC TC4019BP
IC701	8-759-302-98	IC HD614042SA87
IC703	8-759-240-69	IC TC4069UBP
IC704	8-759-700-48	IC NJM2903S
J301	1-507-796-21	JACK
J302	1-507-908-11	JACK, PIN 4P (LINE)
L101	1-408-929-00	MICRO INDUCTOR 27MMH
L102	1-408-926-11	MICRO INDUCTOR 15MMH
L103	1-408-923-00	MICRO INDUCTOR 8.2MMH
L104	1-408-924-00	MICRO INDUCTOR 10MMH
L201	1-408-929-00	MICRO INDUCTOR 27MMH
L202	1-408-926-11	MICRO INDUCTOR 15MMH
L203	1-408-923-00	MICRO INDUCTOR 8.2MMH
L204	1-408-924-00	MICRO INDUCTOR 10MMH
LPF101	1-231-388-00	FILTER, LOW PASS
LPF201	1-231-388-00	FILTER, LOW PASS
M1001	X-3391-130-1	MOTOR ASSY
M1002	X-3391-131-1	MOTOR ASSY
PL301	1-518-386-00	LAMP, PILOT
PM1001	1-454-428-11	SOLENOID, PLUNGER
Q101	8-729-100-13	TRANSISTOR 2SC2001-K2
Q102	8-729-107-88	TRANSISTOR 2SC3622A-L
Q103	8-729-107-88	TRANSISTOR 2SC3622A-L
Q104	8-729-107-88	TRANSISTOR 2SC3622A-L
Q105	8-729-107-88	TRANSISTOR 2SC3622A-L
Q106	8-729-107-88	TRANSISTOR 2SC3622A-L
Q107	8-729-107-88	TRANSISTOR 2SC3622A-L
Q108	8-729-107-88	TRANSISTOR 2SC3622A-L
Q109	8-729-900-80	TRANSISTOR DTC114ES
Q201	8-729-100-13	TRANSISTOR 2SC2001-K2
Q202	8-729-107-88	TRANSISTOR 2SC3622A-L
Q203	8-729-107-88	TRANSISTOR 2SC3622A-L
Q204	8-729-107-88	TRANSISTOR 2SC3622A-L
Q205	8-729-107-88	TRANSISTOR 2SC3622A-L
Q206	8-729-107-88	TRANSISTOR 2SC3622A-L

ELECTRICAL PARTS

Ref.No.	Part No.	Description
Q207	8-729-107-88	TRANSISTOR 2SC3622A-L
Q208	8-729-107-88	TRANSISTOR 2SC3622A-L
Q209	8-729-900-80	TRANSISTOR DTC114ES
Q301	8-729-900-80	TRANSISTOR DTC114ES
Q302	8-729-606-33	TRANSISTOR 2SC2603F
Q303	8-729-900-80	TRANSISTOR DTC114ES
Q304	8-729-900-80	TRANSISTOR DTC144ES
Q305	8-729-107-88	TRANSISTOR 2SC3622A-L
Q306	8-729-900-80	TRANSISTOR DTC114ES
Q307	8-729-900-65	TRANSISTOR DTA114ES
Q308	8-729-900-61	TRANSISTOR DTA114ES
Q309	8-729-900-61	TRANSISTOR DTA114ES
Q310	8-729-900-61	TRANSISTOR DTA114ES
Q311	8-729-900-61	TRANSISTOR DTA114ES
Q312	8-729-900-80	TRANSISTOR DTC114ES
Q313	8-729-900-61	TRANSISTOR DTA114ES
Q315	8-729-900-80	TRANSISTOR DTC144ES
Q316	8-729-117-54	TRANSISTOR 2SA1175
Q317	8-729-600-27	TRANSISTOR 2SC634SP
Q318	8-729-600-27	TRANSISTOR 2SC634SP
Q319	8-729-900-80	TRANSISTOR DTC114ES
Q320	8-729-900-80	TRANSISTOR DTC114ES
Q501	8-729-201-56	TRANSISTOR 2SK246-GR2
Q502	8-729-606-33	TRANSISTOR 2SC2603F
Q503	8-729-606-33	TRANSISTOR 2SC2603F
Q504	8-729-180-93	TRANSISTOR 2SD809
Q505	8-729-117-54	TRANSISTOR 2SA1175
Q506	8-729-117-54	TRANSISTOR 2SA1175
Q507	8-729-173-13	TRANSISTOR 2SB731
Q508	8-729-201-56	TRANSISTOR 2SK246-GR2
Q509	8-729-606-33	TRANSISTOR 2SC2603F
Q510	8-729-900-80	TRANSISTOR DTC114ES
Q511	8-729-364-72	TRANSISTOR 2SB647
Q512	8-729-110-68	TRANSISTOR 2SA1409-L
Q513	8-729-107-25	TRANSISTOR 2SD1585-L
Q514	8-729-900-74	TRANSISTOR DTC143TS
Q515	8-729-606-33	TRANSISTOR 2SC2603F
Q516	8-729-180-93	TRANSISTOR 2SD809
Q518	8-729-107-88	TRANSISTOR 2SC3622A-L
Q519	8-729-900-61	TRANSISTOR DTA114ES
Q520	8-729-900-80	TRANSISTOR DTC114ES
Q521	8-729-606-33	TRANSISTOR 2SC2603F
Q522	8-729-900-61	TRANSISTOR DTA114ES
Q523	8-729-900-61	TRANSISTOR DTA114ES
Q525	8-729-900-61	TRANSISTOR DTA114ES
Q526	8-729-801-83	TRANSISTOR 2SB1013
Q527	8-729-800-83	TRANSISTOR 2SB808
Q528	8-729-177-44	TRANSISTOR 2S0774-5
Q529	8-729-801-83	TRANSISTOR 2SB1013
Q530	8-729-801-83	TRANSISTOR 2SB1013
Q531	8-729-801-93	TRANSISTOR 2SD1387
Q532	8-729-801-93	TRANSISTOR 2SD1387
Q533	8-729-801-83	TRANSISTOR 2SB1013
Q534	8-729-900-61	TRANSISTOR DTA114ES
Q535	8-729-900-61	TRANSISTOR DTA114ES
Q536	8-729-900-61	TRANSISTOR DTA114ES
Q537	8-729-900-61	TRANSISTOR DTC114ES

The components identified by shading and mark  are critical for safety. Replace only with part number specified.

Les composants identifiés par une trame et une marque  sont critiques pour la sécurité. Ne les remplacer que par une pièce portant le numéro spécifié.

ELECTRICAL PARTS

Ref.No.	Part No.	Description
Q538	8-729-107-88	TRANSISTOR 2SC3622A-L
Q539	8-729-900-80	TRANSISTOR DTC114ES
Q540	8-729-900-80	TRANSISTOR DTC114ES
Q541	8-729-900-61	TRANSISTOR DTA114ES
Q542	8-729-180-93	TRANSISTOR 2SD809
Q543	8-729-900-83	TRANSISTOR DTC114ES
Q701	8-729-900-63	TRANSISTOR DTA124ES
Q702	8-729-900-63	TRANSISTOR DTA124ES
Q703	8-729-900-63	TRANSISTOR DTA124ES
Q704	8-729-900-63	TRANSISTOR DTA124ES
Q705	8-729-900-63	TRANSISTOR DTA124ES
Q706	8-729-900-63	TRANSISTOR DTA124ES
Q707	8-729-900-63	TRANSISTOR DTA124ES
Q708	8-729-900-63	TRANSISTOR DTA124ES
Q709	8-729-900-63	TRANSISTOR DTA124ES
Q710	8-729-900-63	TRANSISTOR DTA124ES
Q712	8-729-900-63	TRANSISTOR DTA124ES
Q713	8-729-900-63	TRANSISTOR DTA124ES
Q714	8-729-900-63	TRANSISTOR DTA124ES
Q730	8-729-900-63	TRANSISTOR DTC124ES
Q1002	1-807-509-11	PHOTO SENSOR
Q1003	1-807-509-11	PHOTO SENSOR
R001	1-247-240-00	CARBON 1K 5% 1/2W
R101	1-249-460-11	CARBON 15K 5% 1/4W
R102	1-247-698-11	CARBON 68 5% 1/4W
R103	1-246-524-00	CARBON 130K 5% 1/4W
R104	1-247-148-00	CARBON 5.1K 5% 1/4W
R105	1-247-859-00	CARBON 15K 5% 1/6W
R106	1-247-717-11	CARBON 2.2K 5% 1/4W
R107	1-247-718-11	CARBON 2.7K 5% 1/4W
R108	1-247-887-00	CARBON 220K 5% 1/6W
R109	1-249-429-11	CARBON 10K 5% 1/6W
R110	1-249-429-11	CARBON 10K 5% 1/6W
R111	1-249-441-11	CARBON 100K 5% 1/6W
R112	1-247-719-11	CARBON 3.3K 5% 1/4W
R113	1-247-151-00	CARBON 6.8K 5% 1/4W
R114	1-246-488-00	CARBON 4.3K 5% 1/4W
R115	1-247-140-00	CARBON 2.4K 5% 1/4W
R116	1-247-122-00	CARBON 430 5% 1/4W
R117	1-247-851-00	CARBON 6.8K 5% 1/6W
R118	1-249-415-11	CARBON 680 5% 1/6W
R119	1-247-713-11	CARBON 1K 5% 1/4W
R120	1-247-725-11	CARBON 10K 5% 1/4W
R121	1-249-465-11	CARBON 47K 5% 1/4W
R122	1-249-429-11	CARBON 10K 5% 1/6W
R124	1-249-433-11	CARBON 22K 5% 1/6W
R125	1-247-725-11	CARBON 10K 5% 1/4W
R126	1-247-725-11	CARBON 10K 5% 1/4W
R127	1-249-421-11	CARBON 2.2K 5% 1/6W
R128	1-249-469-11	CARBON 100K 5% 1/4W
R129	1-247-151-00	CARBON 6.8K 5% 1/4W
R130	1-247-169-00	CARBON 39K 5% 1/4W
R131	1-249-467-11	CARBON 68K 5% 1/4W
R132	1-247-151-00	CARBON 6.8K 5% 1/4W
R133	1-247-704-11	CARBON 220 5% 1/4W
R134	1-247-153-00	CARBON 8.2K 5% 1/4W
R135	1-247-163-00	CARBON 22K 5% 1/4W
R136	1-247-148-00	CARBON 5.1K 5% 1/4W

ELECTRICAL PARTS

Ref.No.	Part No.	Description
R138	1-247-167-00	CARBON 33K 5% 1/4W
R139	1-247-145-00	CARBON 3.9K 5% 1/4W
R140	1-249-429-11	CARBON 10K 5% 1/6W
R141	1-249-429-11	CARBON 10K 5% 1/6W
R142	1-249-429-11	CARBON 10K 5% 1/6W
R143	1-249-425-11	CARBON 4.7K 5% 1/6W
R144	1-249-432-11	CARBON 18K 5% 1/6W
R145	1-247-883-00	CARBON 150K 5% 1/6W
R146	1-249-433-11	CARBON 22K 5% 1/6W
R148	1-249-421-11	CARBON 2.2K 5% 1/6W
R149	1-247-862-00	CARBON 20K 5% 1/6W
R150	1-247-704-11	CARBON 220 5% 1/4W
R151	1-247-167-00	CARBON 33K 5% 1/4W
R152	1-247-713-11	CARBON 1K 5% 1/4W
R153	1-247-717-11	CARBON 2.2K 5% 1/4W
R154	1-249-421-11	CARBON 2.2K 5% 1/6W
R155	1-249-441-11	CARBON 100K 5% 1/6W
R156	1-249-417-11	CARBON 1K 5% 1/6W
R157	1-249-429-11	CARBON 10K 5% 1/6W
R158	1-249-433-11	CARBON 22K 5% 1/6W
R159	1-247-845-00	CARBON 3.9K 5% 1/6W
R160	1-249-429-11	CARBON 10K 5% 1/6W
R162	1-247-713-11	CARBON 1K 5% 1/4W
R163	1-249-433-11	CARBON 22K 5% 1/6W
R164	1-249-433-11	CARBON 22K 5% 1/6W
R165	1-247-813-00	CARBON 180 5% 1/6W
R166	1-247-869-00	CARBON 39K 5% 1/6W
R167	1-249-417-11	CARBON 1K 5% 1/6W
R168	1-249-429-11	CARBON 10K 5% 1/6W
R169	1-249-429-11	CARBON 10K 5% 1/6W
R170	1-249-465-11	CARBON 47K 5% 1/4W
R301	1-247-704-11	CARBON 220 5% 1/4W
R302	1-247-704-11	CARBON 220 5% 1/4W
R303	1-249-433-11	CARBON 22K 5% 1/6W
R304	1-215-469-00	METAL 100K 1% 1/6W
R305	1-249-429-11	CARBON 10K 5% 1/6W
R306	1-247-859-00	CARBON 15K 5% 1/6W
R307	1-249-421-11	CARBON 2.2K 5% 1/6W
R308	1-249-405-11	CARBON 100 5% 1/6W
R309	1-249-441-11	CARBON 100K 5% 1/6W
R312	1-249-433-11	CARBON 22K 5% 1/6W
R313	1-249-433-11	CARBON 22K 5% 1/6W
R314	1-249-441-11	CARBON 100K 5% 1/6W
R315	1-249-429-11	CARBON 10K 5% 1/6W
R316	1-249-429-11	CARBON 10K 5% 1/6W
R317	1-249-441-11	CARBON 100K 5% 1/6W
R318	1-249-419-11	CARBON 1.5K 5% 1/6W
R319	1-249-437-11	CARBON 47K 5% 1/6W
R320	1-247-823-00	CARBON 470 5% 1/6W
R321	1-247-819-00	CARBON 330 5% 1/6W
R322	1-249-432-11	CARBON 18K 5% 1/6W
R323	1-247-791-00	CARBON 22 5% 1/6W
R324	1-249-432-11	CARBON 18K 5% 1/6W
R325	1-249-429-11	CARBON 10K 5% 1/6W
R326	1-249-429-11	CARBON 10K 5% 1/6W
R327	1-249-425-11	CARBON 4.7K 5% 1/6W
R328	1-249-429-11	CARBON 10K 5% 1/6W

ELECTRICAL PARTS

Ref.No.	Part No.	Description				
R329	1-249-429-11	CARBON	10K	5%	1/6W	
R330	1-249-425-11	CARBON	4.7K	5%	1/6W	
R331	1-249-432-11	CARBON	18K	5%	1/6W	
R332	1-249-441-11	CARBON	100K	5%	1/6W	
R333	1-249-429-11	CARBON	10K	5%	1/6W	
R334	1-247-869-00	CARBON	39K	5%	1/6W	
R335	1-247-869-00	CARBON	39K	5%	1/6W	
R336	1-212-853-00	FUSIBLE	6.3	5%	1/4W	F
R337	1-249-405-11	CARBON	100	5%	1/6W	
R338	1-249-425-11	CARBON	4.7K	5%	1/6W	
R339	1-249-433-11	CARBON	22K	5%	1/6W	
R340	1-249-433-11	CARBON	22K	5%	1/6W	
R341	1-249-417-11	CARBON	1K	5%	1/6W	
R342	1-249-429-11	CARBON	10K	5%	1/6W	
R343	1-249-417-11	CARBON	1K	5%	1/6W	
R346	1-247-717-11	CARBON	2.2K	5%	1/4W	
R347	1-249-429-11	CARBON	10K	5%	1/6W	
R503	1-214-713-00	METAL	220	1%	1/4W	
R504	1-214-731-00	METAL	1.2K	1%	1/4W	
R505	1-214-723-00	METAL	560	1%	1/4W	
R506	1-249-429-11	CARBON	10K	5%	1/6W	
R507	1-214-721-00	METAL	470	1%	1/4W	
R508	1-249-433-11	CARBON	22K	5%	1/6W	
R510	1-249-433-11	CARBON	22K	5%	1/6W	
R511	1-214-747-00	METAL	5.6K	1%	1/4W	
R512	1-214-755-00	METAL	12K	1%	1/4W	
R513	1-247-163-00	CARBON	22K	5%	1/4W	
R514	1-247-721-11	CARBON	4.7K	5%	1/4W	
R515	1-247-849-00	CARBON	5.6K	5%	1/6W	
R516	1-249-417-11	CARBON	1K	5%	1/6W	
R517	1-247-717-11	CARBON	2.2K	5%	1/4W	
R518	1-247-240-00	CARBON	1K	5%	1/2W	
R519	1-249-405-11	CARBON	100	5%	1/6W	
R520	1-249-432-11	CARBON	18K	5%	1/6W	
R521	1-247-857-00	CARBON	12K	5%	1/6W	
R522	1-247-783-00	CARBON	10	5%	1/6W	
R523	1-249-433-11	CARBON	22K	5%	1/6W	
R524	1-247-903-00	CARBON	1M	5%	1/6W	
R525	1-249-422-11	CARBON	2.7K	5%	1/6W	
R526	1-249-441-11	CARBON	100K	5%	1/6W	
R528	1-249-429-11	CARBON	10K	5%	1/6W	
R529	1-247-903-00	CARBON	1M	5%	1/6W	
R530	1-249-429-11	CARBON	10K	5%	1/6W	
R531	1-249-417-11	CARBON	1K	5%	1/6W	
R532	1-249-437-11	CARBON	47K	5%	1/6W	
R533	1-249-433-11	CARBON	22K	5%	1/6W	
R534	1-249-433-11	CARBON	22K	5%	1/6W	
R535	1-249-437-11	CARBON	47K	5%	1/6W	
R536	1-249-437-11	CARBON	47K	5%	1/6W	
R537	1-247-857-00	CARBON	12K	5%	1/6W	
R538	1-249-425-11	CARBON	4.7K	5%	1/6W	
R539	1-247-857-00	CARBON	12K	5%	1/6W	
R540	1-247-708-11	CARBON	470	5%	1/4W	
R541	1-249-433-11	CARBON	22K	5%	1/6W	
R542	1-249-433-11	CARBON	22K	5%	1/6W	
R543	1-247-808-00	CARBON	110	5%	1/6W	
R544	1-249-425-11	CARBON	4.7K	5%	1/6W	

ELECTRICAL PARTS

Ref.No.	Part No.	Description				
R551	1-247-823-00	CARBON	470	5%	1/6W	
R552	1-247-823-00	CARBON	470	5%	1/6W	
R553	1-247-823-00	CARBON	470	5%	1/6W	
R554	1-247-823-00	CARBON	470	5%	1/6W	
R555	1-247-823-00	CARBON	470	5%	1/6W	
R556	1-247-823-00	CARBON	470	5%	1/6W	
R557	1-247-823-00	CARBON	470	5%	1/6W	
R558	1-247-823-00	CARBON	470	5%	1/6W	
R559	1-247-823-00	CARBON	470	5%	1/6W	
R560	1-247-823-00	CARBON	470	5%	1/6W	
R561	1-249-433-11	CARBON	22K	5%	1/6W	
R562	1-249-433-11	CARBON	22K	5%	1/6W	
R563	1-249-433-11	CARBON	22K	5%	1/6W	
R564	1-249-433-11	CARBON	22K	5%	1/6W	
R565	1-249-433-11	CARBON	22K	5%	1/6W	
R566	1-249-433-11	CARBON	22K	5%	1/6W	
R567	1-249-433-11	CARBON	22K	5%	1/6W	
R568	1-249-433-11	CARBON	22K	5%	1/6W	
R569	1-249-433-11	CARBON	22K	5%	1/6W	
R570	1-249-433-11	CARBON	22K	5%	1/6W	
R571	1-249-433-11	CARBON	22K	5%	1/6W	
R572	1-249-433-11	CARBON	22K	5%	1/6W	
R578	1-247-859-00	CARBON	15K	5%	1/6W	
R579	1-249-425-11	CARBON	4.7K	5%	1/6W	
R580	1-247-857-00	CARBON	12K	5%	1/6W	
R581	1-247-862-00	CARBON	20K	5%	1/6W	
R582	1-249-435-11	CARBON	33K	5%	1/6W	
R583	1-249-435-11	CARBON	33K	5%	1/6W	
R584	1-247-887-00	CARBON	220K	5%	1/6W	
R585	1-247-887-00	CARBON	220K	5%	1/6W	
R586	1-247-813-00	CARBON	180	5%	1/6W	
R587	1-247-813-00	CARBON	180	5%	1/6W	
R588	1-247-813-00	CARBON	180	5%	1/6W	
R589	1-247-813-00	CARBON	180	5%	1/6W	
R590	1-247-843-00	CARBON	3.3K	5%	1/6W	
R591	1-247-843-00	CARBON	3.3K	5%	1/6W	
R592	1-249-417-11	CARBON	1K	5%	1/6W	
R593	1-249-415-11	CARBON	680	5%	1/6W	
R594	1-249-421-11	CARBON	2.2K	5%	1/6W	
R595	1-249-417-11	CARBON	1K	5%	1/6W	
R596	1-249-417-11	CARBON	1K	5%	1/6W	
R597	1-249-417-11	CARBON	1K	5%	1/6W	
R598	1-249-417-11	CARBON	1K	5%	1/6W	
R599	1-247-833-00	CARBON	1.2K	5%	1/6W	
R600	1-249-405-11	CARBON	100	5%	1/6W	
R601	1-247-823-00	CARBON	470	5%	1/6W	
R602	1-249-425-11	CARBON	4.7K	5%	1/6W	
R604	1-249-435-11	CARBON	33K	5%	1/6W	
R605	1-249-433-11	CARBON	22K	5%	1/6W	
R606	1-249-441-11	CARBON	100K	5%	1/6W	
R607	1-247-815-00	CARBON	220	5%	1/6W	
R608	1-247-815-00	CARBON	220	5%	1/6W	
R715	1-249-429-11	CARBON	10K	5%	1/6W	
R716	1-249-425-11	CARBON	4.7K	5%	1/6W	
R730	1-215-452-00	METAL	20K	1%	1/6W	
R731	1-215-452-00	METAL	20K	1%	1/6W	
R732	1-215-452-00	METAL	20K	1%	1/6W	

The components identified by shading and mark Δ are critical for safety. Replace only with part number specified.

Les composants identifiés par une trame et une marque Δ sont critiques pour la sécurité. Ne les remplacer que par une pièce portant le numéro spécifié.

ELECTRICAL PARTS

Ref.No.	Part No.	Description			
R733	1-215-452-00	METAL	20K	1%	1/6W
R734	1-215-452-00	METAL	20K	1%	1/6W
R735	1-215-452-00	METAL	20K	1%	1/6W
R736	1-215-452-00	METAL	20K	1%	1/6W
R737	1-215-445-00	METAL	10K	1%	1/6W
R738	1-215-445-00	METAL	10K	1%	1/6W
R739	1-215-445-00	METAL	10K	1%	1/6W
R740	1-215-445-00	METAL	10K	1%	1/6W
R741	1-215-445-00	METAL	10K	1%	1/6W
R742	1-215-445-00	METAL	10K	1%	1/6W
R743	1-215-460-00	METAL	43K	1%	1/6W
R744	1-215-425-00	METAL	1.5K	1%	1/6W
R745	1-249-425-11	CARBON	4.7K	5%	1/6W
R746	1-249-425-11	CARBON	4.7K	5%	1/6W
R750	1-249-433-11	CARBON	22K	5%	1/6W
R762	1-247-712-11	CARBON	820	5%	1/4W
R771	1-249-417-11	CARBON	1K	5%	1/6W
R772	1-249-433-11	CARBON	22K	5%	1/6W
R773	1-249-417-11	CARBON	1K	5%	1/6W
R774	1-249-433-11	CARBON	22K	5%	1/6W
RV101	1-228-994-00	RES, ADJ, CARBON 10K			
RV102	1-237-274-11	RES, VAR, CARBON 10K/10K			
RV103	1-230-632-11	RES, ADJ, CARBON 33K			
RV104	1-228-995-00	RES, ADJ, CARBON 22K			
RV105	1-228-996-00	RES, ADJ, CARBON 47K			
RV106	1-228-995-00	RES, ADJ, CARBON 22K			
RV201	1-228-994-00	RES, ADJ, CARBON 10K			
RV202	1-237-274-11	RES, VAR, CARBON 10K/10K			
RV203	1-230-632-11	RES, ADJ, CARBON 33K			
RV204	1-228-995-00	RES, ADJ, CARBON 22K			
RV205	1-228-996-00	RES, ADJ, CARBON 47K			
RV206	1-228-995-00	RES, ADJ, CARBON 22K			
RV301	1-226-754-31	RES, VAR 20K/20K			
RV302	1-230-313-00	RES, VAR, CARBON 20K/20K			
RV501	1-228-995-00	RES, ADJ, CARBON 22K			
RY301	1-515-547-11	RELAY			
S301	1-570-103-21	SWITCH, PUSH (1 KEY){POWER}			
S302	1-570-532-11	SWITCH, PUSH (5 KEY){DOLBY NR}			
S303	1-554-208-00	SWITCH, SLIDE (TIMER)			
S501	1-554-980-11	SWITCH, KEY BOARD (STOP)			
S502	1-554-980-11	SWITCH, KEY BOARD (REW)			
S503	1-554-980-11	SWITCH, KEY BOARD (FF)			
S504	1-554-980-11	SWITCH, KEY BOARD (FWD)			
S505	1-554-980-11	SWITCH, KEY BOARD (REV)			
S506	1-554-980-11	SWITCH, KEY BOARD (REC)			

ELECTRICAL PARTS

Ref.No.	Part No.	Description
S507	1-554-980-11	SWITCH, KEY BOARD (PAUSE)
S508	1-554-980-11	SWITCH, KEY BOARD (REC MUTE)
S509	1-554-980-11	SWITCH, KEY BOARD (TAPE OPR)
S510	1-554-980-11	SWITCH, KEY BOARD (CAL)
S771	1-554-980-11	SWITCH, KEY BOARD (RESET)
S772	1-554-980-11	SWITCH, KEY BOARD (MEMORY)
S1001	1-570-707-11	(S) SWITCH, VOLTAGE CHANGE
S1001	1-570-720-11	SWITCH, PUSH (1 KEY)
S1002	1-570-720-11	SWITCH, PUSH (1 KEY)
S1005	1-570-723-11	SWITCH, PUSH (1 KEY)
S1006	1-570-719-11	SWITCH, LEAF
S1007	1-570-721-11	SWITCH, LEAF
SPK101	1-235-186-00	ENCAPSULATED COMPONENT
SPK201	1-235-186-00	ENCAPSULATED COMPONENT
T101	1-433-316-11	TRANSFORMER, BIAS STEP UP
T201	1-433-316-11	TRANSFORMER, BIAS STEP UP
T301	1-433-315-11	(US,Canadian) TRANSFORMER, POWER
T302	1-433-315-11	(AEP,UK,E) TRANSFORMER, POWER
T302	1-433-315-11	TRANSFORMER, BIAS OSCILLATION
TP1	*1-560-061-00	PIN, CONNECTOR 3P
X501	1-567-160-00	OSCILLATOR, CERAMIC
X502	1-527-532-00	OSCILLATOR, CERAMIC

ACCESSORY & PACKING MATERIAL

Part No.	Description
1-558-233-11	CORD (WITH CONNECTOR)(SIRCS)4P
1-558-543-11	CORD, CONNECTION
3-318-958-01	CUSHION (LEFT), LOWER
3-318-959-01	CUSHION (RIGHT), LOWER
3-318-960-01	CUSHION (LEFT), UPPER
3-318-961-01	CUSHION (RIGHT), UPPER
3-324-801-41	(US,Canadian)...INDIVIDUAL CARTON
3-324-801-51	(AEP,UK,E).....INDIVIDUAL CARTON
3-701-630-00	BAG, POLYETHYLENE
3-703-450-01	INSTRUCTION
3-703-680-00	LABEL, CAUTION, SUB, NEW UL
3-765-223-11	(AEP,UK,E).....MANUAL, INSTRUCTION
3-765-223-21	(US,Canadian)...MANUAL, INSTRUCTION
3-765-223-31	(Canadian).....MANUAL, INSTRUCTION
3-765-223-41	(AEP).....MANUAL, INSTRUCTION
4-876-352-00	SHEET, PROTECTION

The components identified by shading and mark **A** are critical for safety. Replace only with part number specified.

Les composants identifiés par une trame et une marque **A** sont critiques pour la sécurité. Ne les remplacer que par une pièce portant le numéro spécifié.

