

TC-KE200/KE300/KE400S/RX300

SERVICE MANUAL

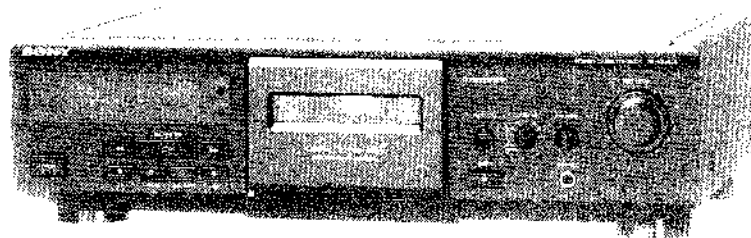

Photo: TC-KE400S.

US Model
TC-KE400S

Canadian Model
TC-RX300

AEP Model
TC-KE200/KE300/KE400S

UK Model
TC-KE200/KE300S

E Model
TC-KE200

Austrian Model
TC-KE300SE-01

* Dolby C noise reduction system is a registered trademark and a license from Dolby Laboratories Licensing Corporation, 345 Page Street, Redwood City, California.

"DOLBY" the double-D symbol, CC, and "DNR" are trademarks of Dolby Laboratories Licensing Corporation.

© 1981 Sony Electronics Corporation
All rights reserved.

Printed in Japan
1981

TC-KE400S (USA) 50X36

TC-KE200/KE300 (AEP) 50X36

TC-KE200/KE300S (UK) 50X36

TC-KE200 (E) 50X36

TC-RX300 (CAN) 50X36

SPECIFICATIONS

System

Standard
Type I (C-60, C-90, C-120)
Type II (C-60, C-90, C-120)

Recording system

4 track 2 channel stereo

Frequency response: 20 Hz to 20 kHz
±1 dB

Fast winding time (approx.)

At 100% speed: 10 min. or less

At 50% speed: 20 min. or less

Bias

AC bias

Frequency response: 20 Hz to 20 kHz
±1 dB
Distortion: 0.1% or less
S/N ratio: 50 dB or more

Heads

Printing head: 1.5 inch
Playing/Recording head: 1.5 inch

Frequency response: 20 Hz to 20 kHz
±1 dB
Distortion: 0.1% or less
S/N ratio: 50 dB or more

Motors

Capstan motor: 1.4 W synchronous
Reel motor: 1.1 W, motor

Frequency response: 20 Hz to 20 kHz
±1 dB
Distortion: 0.1% or less
S/N ratio: 50 dB or more

Signal-to-noise ratio (at peak level, weighted, and with Dolby noise reduction)

Type I tape: Sony Type I (N) G-M, 50 dB
Type II tape: Sony Type II (H) G-M, 57 dB
Type W tape: Sony Type W (M) G-M, 57 dB

Frequency response: 20 Hz to 20 kHz
±1 dB
Distortion: 0.1% or less
S/N ratio: 50 dB or more

Continued on page 2

S/N ratio improvement (approximate values)

With Dolby B NR: 11 dB (Type I), 13 dB (Type II)
With Dolby C NR: 15 dB (Type I), 17 dB (Type II)



STEREO CASSETTE DECK
SONY

TABLE OF CONTENTS

Type IV tape, Sony Type IV (METAL) :

EXCEPT KE200

30-18,000 Hz (± 3 dB, IEC)

30-13,000 Hz (± 3 dB, - 4 dB recording)

20-19,000 Hz (± 6 dB)

KE200

30-15,000 Hz (± 3 dB, IEC)

30-13,000 Hz (± 3 dB, - 4 dB recording)

20-16,000 Hz (± 6 dB)

Wow and flutter

± 0.13% W. Peak (IEC)

0.07% W. RMS (NAB)

± 0.18% W. Peak (DIN)

Inputs

Line inputs (phono jacks)

Sensitivity: 0.16 V

Input impedance: 47 kilohms

Outputs

Line outputs (phono jacks)

Rated output level: 0.5 V at a load impedance of
47 kilohms

Load impedance: Over 10 kilohms

Headphones (stereo phone jack)

Output level: 0.25 mW at a load impedance of
32 ohms

General

Power requirements

Where purchased	Power requirements
US, Canadian model	120 V AC, 60 Hz
AEP, UK, German, Malaysia, Singapore model	220 - 230 V AC, 50/60 Hz
Australian model	240 V AC, 50/60 Hz
E model	110 - 120 V or 220 - 240 V AC, 50/60 Hz adjustable with the voltage selector

Power consumption

19 W (EXCEPT KE400S)

20 W (KE400S)

Dimensions (approx.) (w/h/d)

430 × 120 × 310 mm (17 × 4 3/4 × 12 1/4 inches)

incl. projecting parts and controls

Mass (approx.)

3.5 kg (7 lbs 11 oz)

Supplied accessories

Audio connecting cords (2)

Design and specifications are subject to change without notice.

Specifications 1

1. GENERAL

Identifying the Parts on the Front Panel 4

2. DISASSEMBLY

2-1. Front Panel Removal 5

2-2. Mechanism Deck Section Removal 5

2-3. Head and Pinch Roller Removal 6

2-4. Fitting Base Block Removal 6

2-5. Motor Removal 6

3. ADJUSTMENTS

3-1. Mechanical Adjustments 7

3-2. Electrical Adjustments 7

4. EXPLANATION OF IC TERMINALS 10

5. DIAGRAMS

5-1. Printed Wiring Boards - Main Section -
(TC-KE200/KE300/RX300) 12

5-2. Schematic Diagram - Main Section -
(TC-KE200/KE300/RX300) 15

5-3. Schematic Diagram - Main Section -
(TC-KE400S) 20

5-4. Printed Wiring Boards - Main Section -
(TC-KE400S) 25

5-5. Circuit Boards Location 28

5-6. Printed Wiring Boards - Audio Section - 29

5-7. Schematic Diagram - Audio Section - 33

6. EXPLODED VIEWS

6-1. Chassis Section 37

6-2. Front Panel Section 39

6-3. Mechanism Section 1 40

6-4. Mechanism Section 2 41

7. ELECTRICAL PARTS LIST 42

SAFETY CHECK-OUT

After correcting the original service problem, perform the following safety check before releasing the set to the customer:

Check the antenna terminals, metal trim, "metallized" knobs, screws, and all other exposed metal parts for AC leakage. Check leakage as described below.

LEAKAGE TEST

The AC leakage from any exposed metal part to earth ground and from all exposed metal parts to any exposed metal part having a return to chassis, must not exceed 0.5 mA (500 microamperes). Leakage current can be measured by any one of three methods.

1. A commercial leakage tester, such as the Simpson 229 or RCA WT-540A. Follow the manufacturers' instructions to use these instruments.
2. A battery-operated AC milliammeter. The Data Precision 245 digital multimeter is suitable for this job.
3. Measuring the voltage drop across a resistor by means of a VOM or battery-operated AC voltmeter. The "limit" indication is 0.75 V, so analog meters must have an accurate low-voltage scale. The Simpson 250 and Sanwa SH-63Trd are examples of a passive VOM that is suitable. Nearly all battery operated digital multimeters that have a 2V AC range are suitable. (See Fig. A)

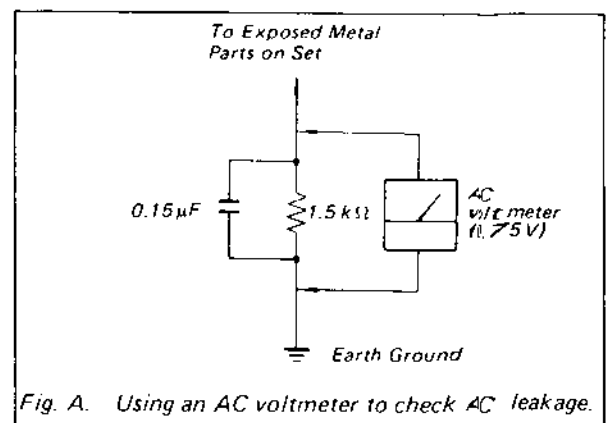
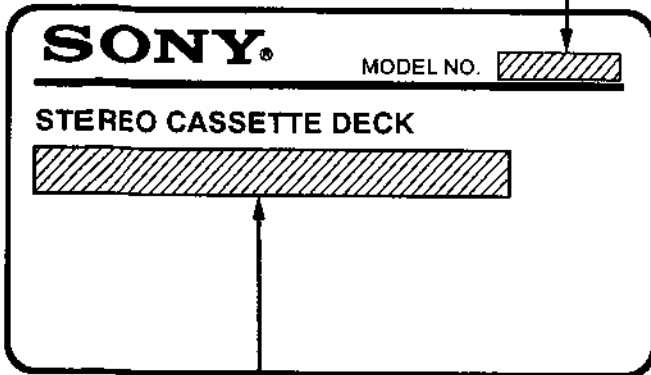

Fig. A. Using an AC voltmeter to check AC leakage.

MODEL IDENTIFICATION



US, Canadian model : AC 120V 60Hz
 Australian model : AC 240V~50/60Hz
 AEP, UK, German, Malaysia,
 Singapore model : AC 220-230V~50/60Hz
 E model : AC 110-120V or 220-240V~50/60Hz

SAFETY-RELATED COMPONENT WARNING!!

COMPONENTS IDENTIFIED BY MARK \triangle OR DOTTED LINE WITH MARK \triangle ON THE SCHEMATIC DIAGRAMS AND IN THE PARTS LIST ARE CRITICAL TO SAFE OPERATION. REPLACE THESE COMPONENTS WITH SONY PARTS WHOSE PART NUMBERS APPEAR AS SHOWN IN THIS MANUAL OR IN SUPPLEMENTS PUBLISHED BY SONY.

ATTENTION AU COMPOSANT AYANT RAPPORT À LA SÉCURITÉ!

LES COMPOSANTS IDENTIFIÉS PAR UNE MARQUE \triangle SUR LES DIAGRAMMES SCHÉMATIQUES ET LA LISTE DES PIÈCES SONT CRITIQUES POUR LA SÉCURITÉ DE FONCTIONNEMENT. NE REMPLACER CES COMPOSANTS QUE PAR DES PIÈCES SONY DONT LES NUMÉROS SONT DONNÉS DANS CE MANUEL OU DANS LES SUPPLÉMENTS PUBLIÉS PAR SONY.

SECTION 1 GENERAL

IDENTIFYING THE PARTS ON THE FRONT PANEL

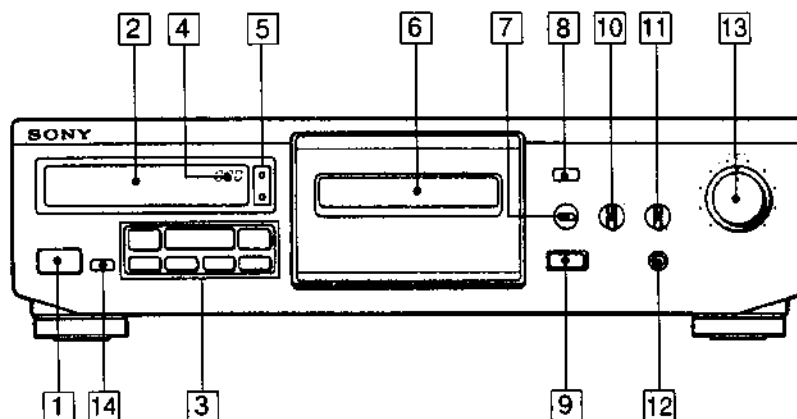

- | | |
|--|---|
| <p>1 POWER switch</p> <p>2 Display panel</p> <p>3 Tape operation buttons</p> <ul style="list-style-type: none"> ◀◀ (rewind) (Multi-AMS™) button ▶ (play) button (KE200/KE300/KE400S) ▶/◀ (forward play and reverse play) button (RX300) ▶▶ (fast-forward) (Multi-AMS™) button ■ (stop) button ⏸ PAUSE button ○ REC MUTE (record muting) button ● REC (record) button <p>4 Tape counter</p> <p>5 Counter buttons</p> <ul style="list-style-type: none"> RESET button MEMORY button | <p>6 Cassette holder</p> <p>7 AUTO CAL button (EXCEPT KE200)</p> <p>8 Remote control sensor</p> <p>9 ⏏ (eject) button</p> <p>10 DOLBY NR (noise reduction) button</p> <p>11 BALANCE control</p> <p>12 PHONES jack (stereo phone jack)</p> <p>13 REC (recording) LEVEL control</p> <p>14 DIRECTION MODE switch (RX300 only)</p> <p style="margin-left: 2em;">*AMS is an abbreviation for Automatic Music Sensor</p> |
|--|---|

SECTION 2 DISASSEMBLY

Note : Follow the disassembly procedure in the numerical order given.

CASE

Unscrew the four case attachment screws M3 × 8 and remove the case.

2-1. FRONT PANEL REMOVAL

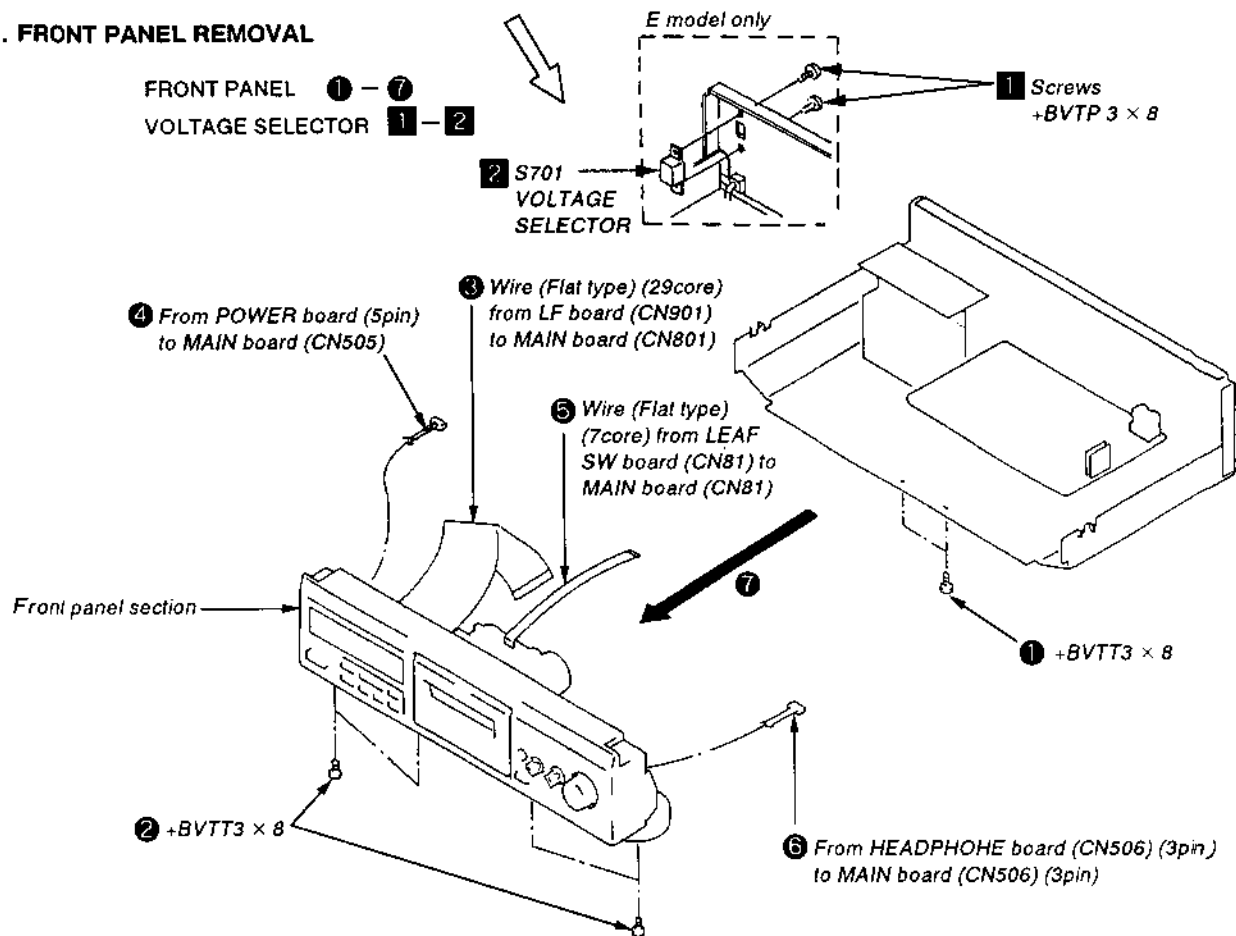

2-2. MECHANISM DECK SECTION REMOVAL

① Press the EJECT button.

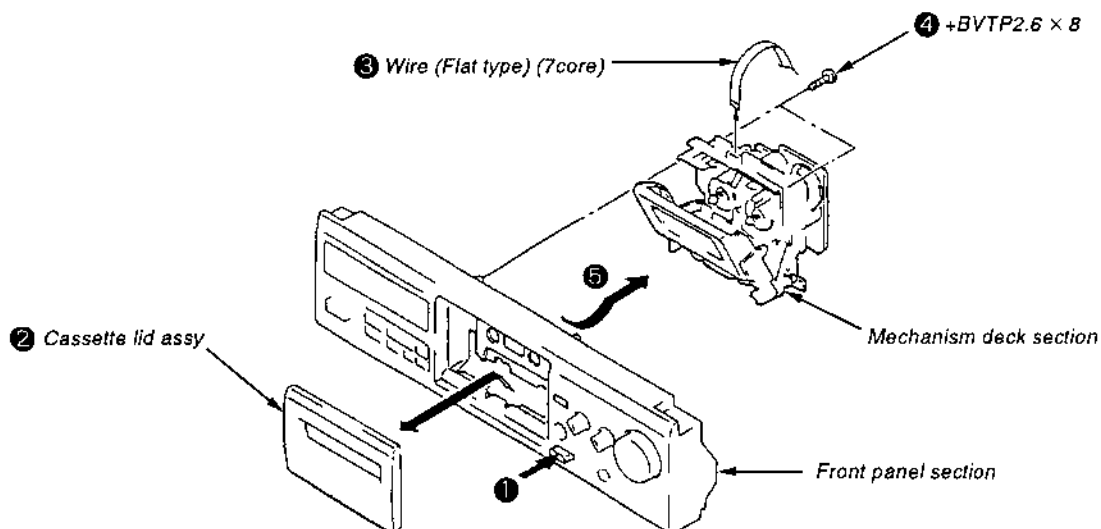

2-3. HEAD AND PINCH ROLLER REMOVAL

EXCEPT TC-RX300 :

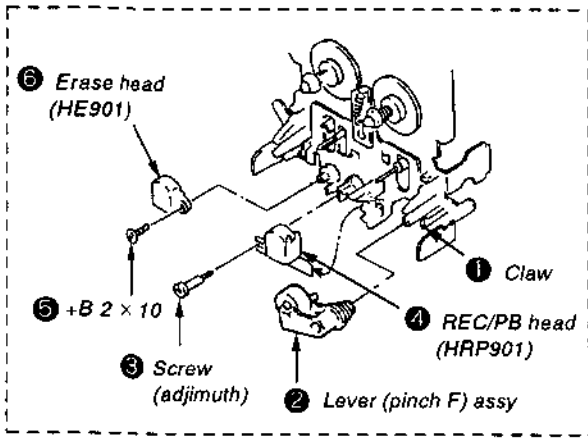

TC-RX300 :

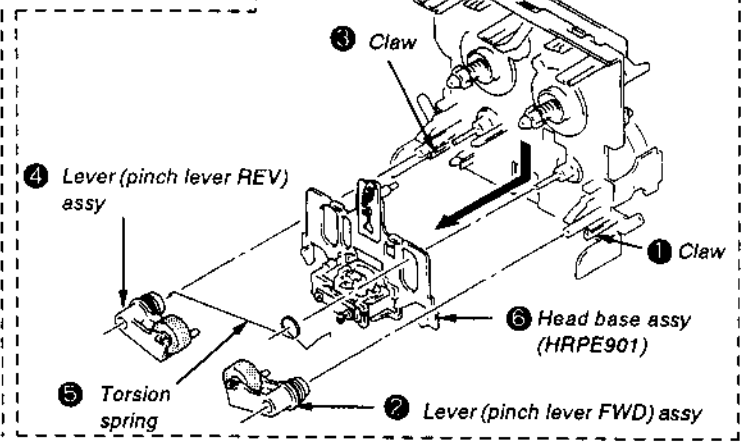

2-4. FITTING BASE BLOCK REMOVAL

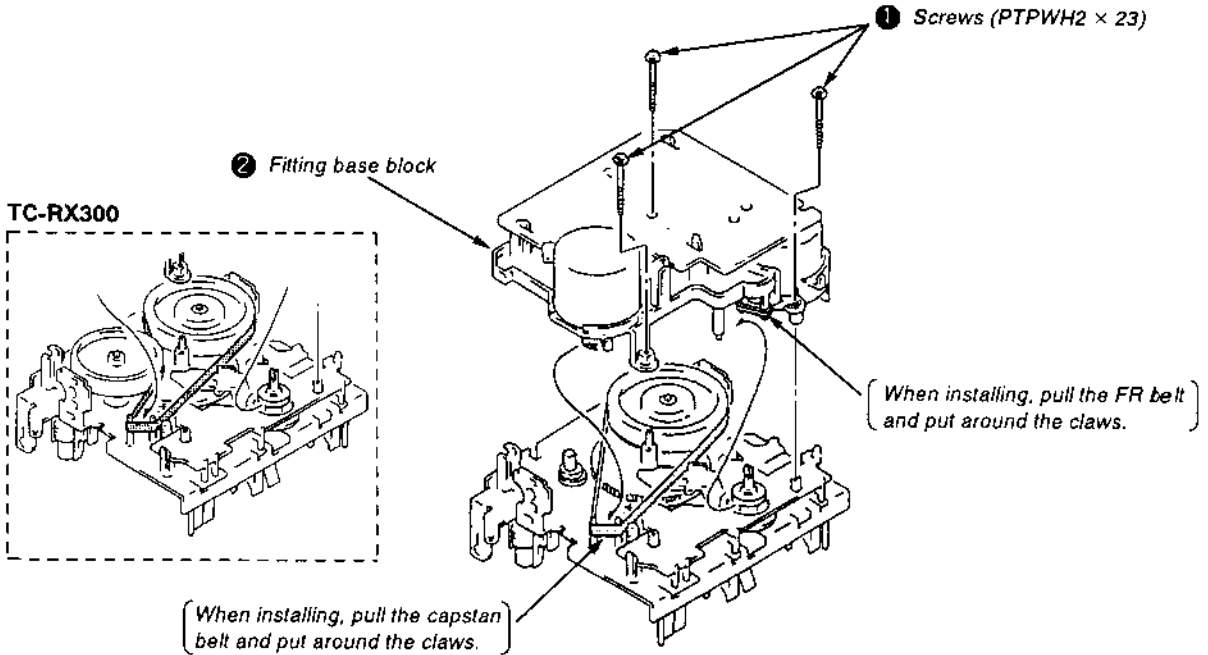

2-5. MOTOR REMOVAL

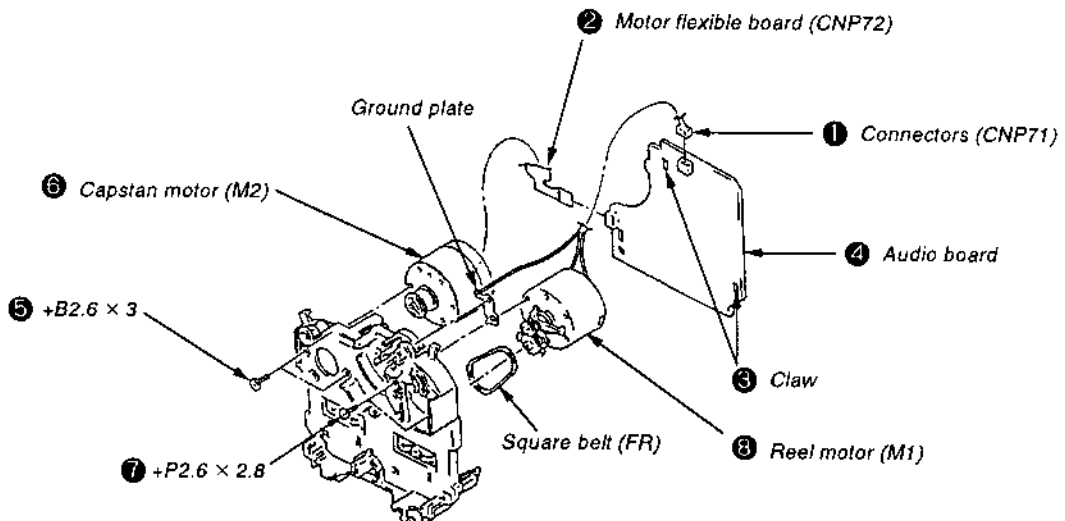

SECTION 3 ADJUSTMENTS

3-1. MECHANICAL ADJUSTMENTS

PRECAUTION

1. Clean the following parts with a denatured alcohol-moistened swab:

record/playback/erase head	pinch roller
rubber belts	capstan
2. Demagnetize the record/playback head with a head demagnetizer.
3. Do not use a magnetized screwdriver for the adjustment.
4. After the adjustments, apply suitable locking compound to the parts adjusted.
5. The adjustments should be performed with the rated power supply voltage unless otherwise noted.

Torque Measurement

Mode	Torque meter	Meter reading
Forward	CQ-102C	35 to 60g • cm (0.48 to 0.83 oz • inch)
Forward back tension	CQ-102C	2 to 60g • cm (0.03 to 0.08 oz • inch)
Reverse (RX300 only)	CQ-102RC	35 to 60g • cm (0.48 to 0.83 oz • inch)
Reverse back tension (RX300 only)	CQ-102RC	2 to 6g • cm (0.03 to 0.08 oz • inch)
FF/REW	CQ-201B	70 to 110g • cm (0.98 to 1.52 oz • inch)

3-2. ELECTRICAL ADJUSTMENTS

PRECAUTION

1. The adjustment should be performed in the publication.
(Be sure to make playback adjustment at first.)
2. The adjustments and measurement should be performed for both L-CH and R-CH.
 - Position of switches and controls knobs
DOLBY NR switch : OFF
 - Standard record position:
Deliver the standard input signal level to input jack and set the REC LEVEL control to obtain the standard output signal level as follows.

— Record Mode —

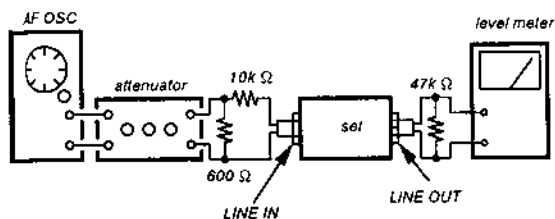

Standard Input Level

Input terminal	LINE IN
source impedance	10k Ω
input signal level	0.5V (- 3 8dB)

Standard Output Level

Output terminal	LINE OUT
load impedance	47k Ω
output signal level	0.5V (- 3 8dB)

Test Tape

Tape	Contents	Use
P-4-A100	10kHz, - 10dB	Azimuth Adjustment
P-4-L300	315Hz, 0dB	PB Level Adjustment
WS-48B	3kHz, 0dB	Tape Speed Adjustment

0dB=0.775V

Test Mode

1. Insert a short-circuit plug into TP801 (2P) and turn ON the power switch. (Earth pin ⑦ of IC801 and turn ON the power switch.)
At first, all the fluorescent tubes light up, then the system returns to normal display. (However, "00 00" is not displayed on the counter.)
2. To release the test mode, remove the short plug and turn off the power switch.
3. Remove the short plug after completion of adjustment.

Record/Playback Head Azimuth Adjustment

Procedure :

1. playback Mode

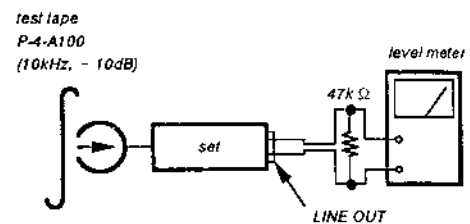

2. Turn the adjustment screw for the maximum output levels. If these levels do not match, turn the adjustment screw until both of output levels match together within 1dB.

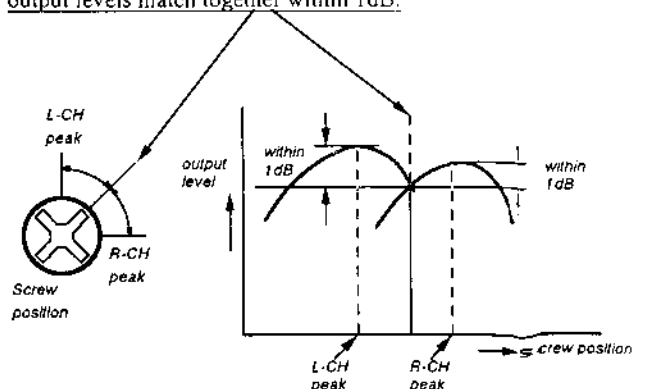

3. Phase check
Playback Mode

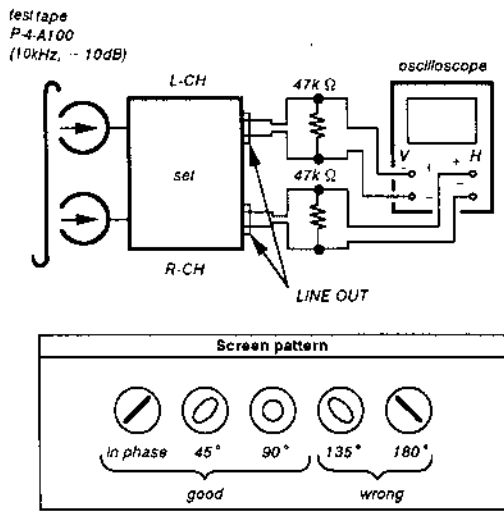

4. After the adjustment, lock the adjustment screws with suitable locking compound.

Adjustment Location : - record/playback head -

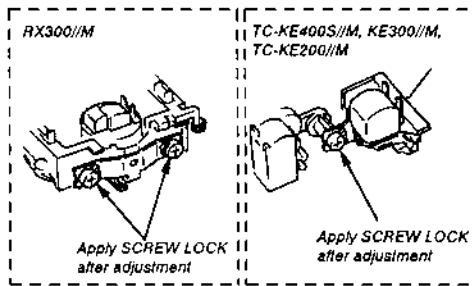

Tape Speed Adjustment

Procedure :
- Playback Mode -

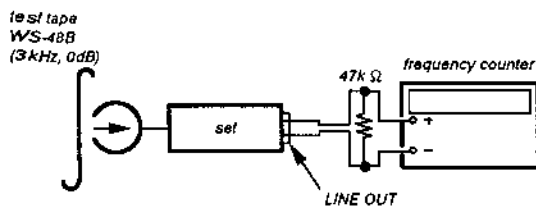

1. Adjust RV71 so that the frequency counter reading becomes $3,000 \pm 10\text{Hz}$.
2. If, the frequency counter reading does not become $3,000 \pm 10\text{Hz}$. Turn RV72 and back to 1st. step again.

Note :

- Turn RV72 to clockwise - Tape speed becomes fast.
- Turn RV72 to counter clockwise - Tape speed becomes slow.

Frequency difference between the beginning and the end of the tape should be within 1%.

Adjustment Location : AUDIO board (Page 9)

Playback Level Adjustment

Procedure :
- Playback Mode -

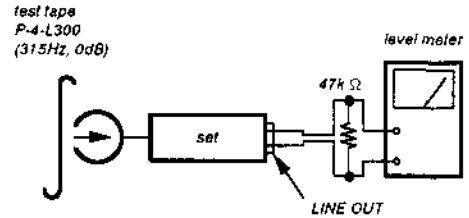

Adjust RV11 (L-CH) and RV21 (R-CH) so the level meter reading becomes the adjustment limits below.

Adjustment Value :

LINE OUT level : $-7.7 \pm 0.5\text{dB}$ (0.301 to 0.338V)

Level difference between channels : within 0.5dB

Confirm the LINE OUT level does not change in playback mode while changing the mode from playback to stop several times

Adjustment Location : AUDIO board (Page 9)

Bias Consumption Current Adjustment

This adjustment should be performed when replacing the head assy or the bias oscillating transformer (T81, T91).

Procedure :
- Record Mode -

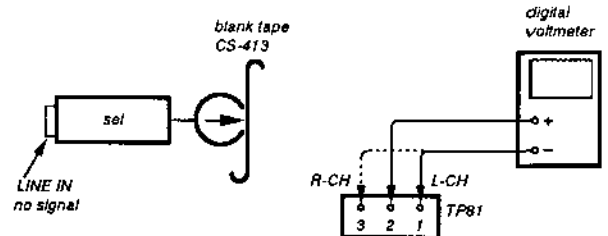

1. Connect the digital voltmeter to test point TP81.
2. Set RV81 (L-CH) and RV91 (R-CH) to mechanical center.
3. Set to record mode.
4. Adjust T81 (L-CH) and T91 (R-CH) so that the digital voltmeter reading becomes minimum.

Adjustment Location : AUDIO board (Page 9)

Record Bias Adjustment

Setting :

REC LEVEL control : standard record position (Refer to page 7)

Procedure :

1. Record Mode

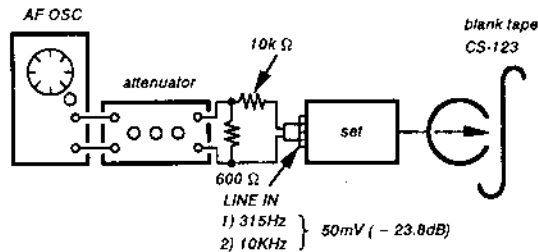

2. Playback Mode

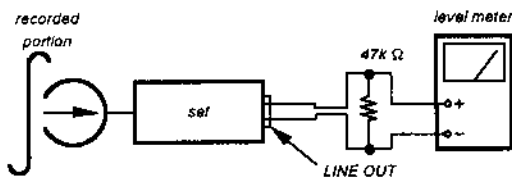

Confirm that the 10kHz playback output is $0 \pm 0.5\text{dB}$ relative to the 315Hz output. If necessary, adjust semi-fixed resistor as shown below and repeat the steps given above.

TC-KE200 : RV12 (L-CH), RV22 (R-CH)

TC-KE300/KE400S/RX300 : RV81 (L-CH), RV91 (R-CH)

Adjustment Location : AUDIO board

Record Level Adjustment

Setting :

REC LEVEL control : standard record position (Refer to page 7)

Procedure :

1. Record Mode

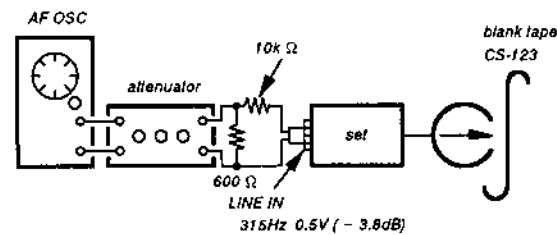

2. Playback Mode

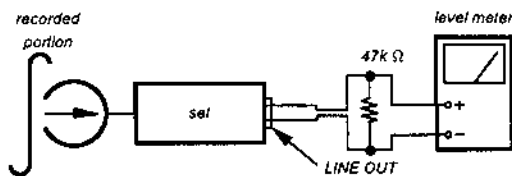

Confirm playback the tape recorded become adjustment level as follows.

If necessary, adjust RV111 (L-CH), RV211 (R-CH) and repeat the steps 1 and 2.

Adjustment Value :

LINE OUT level : $-3.8 \pm 0.5\text{dB}$ (0.47 to 0.53V)

Adjustment Location : MAIN board

- Adjustment Parts Location Diagrams -

[MAIN BOARD]

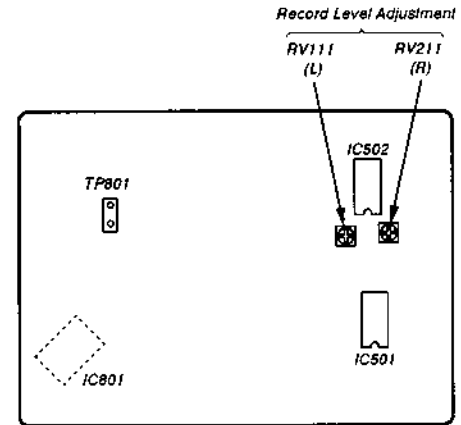

[AUDIO BOARD]

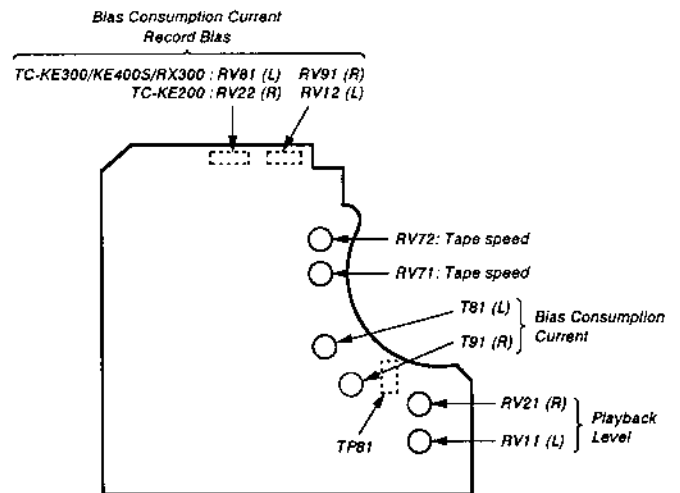

SECTION 4 EXPLANATION OF IC TERMINALS

IC801 CXP82612-022Q (SYSTEM CONTROL)

Pin No.	Pin name	I/O	Description
1	STOP SW	I	Mechanism stop switch input terminal.
2	SIRCS IN	I	SIRCS signal input terminal.
3	VRSION 2	I	Version selector.
4	NC	-	Not used.
5	NC	-	Not used.
6	NC	-	Not used.
7	MPX ON/OFF	O	MPX filter ON/OFF control terminal. OFF=L
8	CAL ON/OFF	O	Calibration ON/OFF control terminal.
9	REC CAL 0	I	REC calibration terminal.
10	REC CAL 1	O	REC calibration terminal.
11	GP CAL 0	O	GP calibration terminal.
12	GP CAL 1	I	GP calibration terminal.
13	LINE MUTE	O	Line mute ON/OFF. 0V=Mute
14	AMS IN	I	AMS signal input terminal.
15	NC	-	Not used.
16	REC MUTE	O	REC out mute terminal.
17	REEL -	O	Reel motor - control terminal.
18	REEL +	O	Reel motor+ control terminal.
19	BIAS	O	Bias ON/OFF.
20	RELAY	O	Relay selector terminal.
21	CAL KEY	I	Calibration ON/OFF switch input terminal.
22	METER L	I	Meter level L ch.
23	KEY X	I	Key switch input terminal.
24	KEY Y	I	Key switch input terminal.
25	METER R	I	Meter level R ch.
26	DOLBY AD	I	Dolby OFF/B/C/S select terminal.
27	HALF	I	Half pawl input terminal.
28	METAL CHROM	I	Metal, CrO ₂ tape selector terminal. "H": Metal, CrO ₂
29	S. REEL	I	Supply pulse input terminal.
30	RESET	I	Reset terminal.
31	XO	O	System clock input terminal.
32	XI	I	System clock output terminal.
33	Vss	-	Ground.
34	BIAS CAL 0	O	Bias calibration terminal.
35	BIAS CAL 1	O	Bias calibration terminal.
36	BIAS CAL 2	O	Bias calibration terminal.
37	BIAS CAL 3	O	Bias calibration terminal.
38	CAP. M ON/OFF	O	Capstan motor ON/OFF terminal.
39	OSC H/L	O	OSC H/L control.
40	OSC ON/OFF	O	OSC ON/OFF control.

Pin No.	Pin name	I/O	Description
41	BC/S	O	Dolby B, C/S select terminal.
42	DOLCON	O	Dolby B/C control terminal.
43	REC/PB	O	Recording/Playback selector for dolby IC.
44	NC	-	Not used.
45	NC	-	Not used.
46	S1	O	Fluorescent indicator tube segment output.
47	S2	O	Fluorescent indicator tube segment output.
48	S3	O	Fluorescent indicator tube segment output.
49	S4	O	Fluorescent indicator tube segment output.
50	S5	O	Fluorescent indicator tube segment output.
51	S6	O	Fluorescent indicator tube segment output.
52	S7	O	Fluorescent indicator tube segment output.
53	S8	O	Fluorescent indicator tube segment output.
54	S9	O	Fluorescent indicator tube segment output.
55	S10	O	Fluorescent indicator tube segment output.
56	S11	O	Fluorescent indicator tube segment output.
57	S12	O	Fluorescent indicator tube segment output.
58	S13	O	Fluorescent indicator tube segment output.
59	S14	O	Fluorescent indicator tube segment output.
60	S15	O	Fluorescent indicator tube segment output.
61	S16	O	Fluorescent indicator tube segment output.
62	S17	O	Fluorescent indicator tube segment output.
63	NC	-	Not used.
64	NC	-	Not used.
65	NC	-	Not used.
66	G5	O	Fluorescent indicator tube grid output.
67	G4	O	Fluorescent indicator tube grid output.
68	G3	O	Fluorescent indicator tube grid output.
69	G2	O	Fluorescent indicator tube grid output.
70	G1	O	Fluorescent indicator tube grid output.
71	V-DISP	-	Fluorescent indicator tube power supply. (-20V)
72	V _{DD}	-	Power supply. (+5V)
73	NC	-	Not used.
74	NC	-	Not used.
75	V _{DD}	-	Power supply. (+5V)
76	POWER IN	I	0V= Power OFF
77	POWER OUT	O	Power ON/OFF. ON=0V
78	V _{DD}	-	Power supply. (+5V)
79	TEST MODE	I	Test mode selector. 0V= Test mode
80	VERSION 1	I	Version selector.

SECTION 5
DIAGRAMS

SEMICONDUCTOR LOCATION

Ref. No.	Location	Ref. No.	Location
D131	D-11	IC511	F-16
D132	D-11	IC601	B-9
D231	D-11	IC701	G-10
D232	D-12	IC801	C-8
D511	B-13	IC802	E-8
D512	B-13		
D513	F-13	Q101	B-14
D551	B-11	Q102	C-14
D701	H-8	Q121	G-12
D702	H-8	Q122	D-13
		Q201	A-14
D703	G-8		
D704	G-8	Q202	C-16
D705	G-8	Q221	G-12
D706	G-8	Q222	E-13
D707	G-8	Q503	G-14
		Q504	G-14
D708	H-9		
D709	H-11	Q505	F-14
D710	G-9	Q511	C-13
D711	G-10	Q512	C-13
D712	F-9	Q521	G-14
		Q531	C-11
D713	G-7		
D714	F-9	Q532	C-11
D715	G-10	Q551	B-11
D801	E-8	Q572	F-13
D802	E-8	Q573	D-13
		Q601	C-10
IC501	D-15	Q701	H-12
IC502	G-15	Q702	H-11
IC503	D-13	Q703	H-9
IC504	D-11	Q704	H-10
IC505	D-11	Q705	G-10
IC506	B-15	Q706	G-9
IC507	C-13	Q707	F-9
IC508	B-10	Q708	F-8
IC509	D-10	Q803	B-7
IC510	C-12	Q805	E-8

Note:

- : parts extracted from the component side.
- △ : internal component.
- ⋯ : Pattern from the side which enables seeing. (The other layers' patterns are not indicated)

Caution:

Pattern face side : Parts on the pattern face side seen from (Conductor Side) the pattern face are indicated.
 Parts face side : Parts on the parts face side seen from the (Component side) parts face are indicated.

Abbreviation
 CND : Canadian

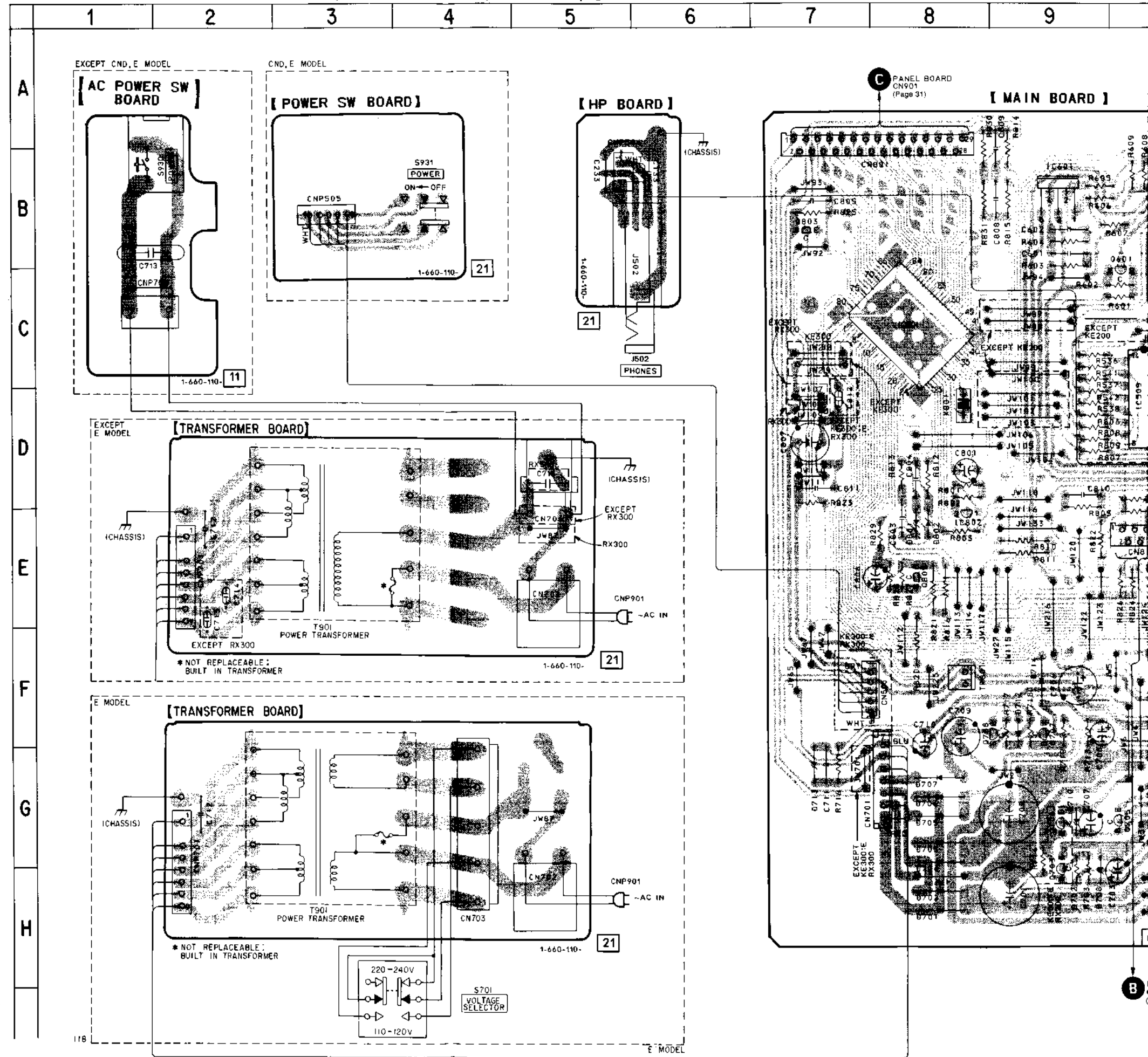

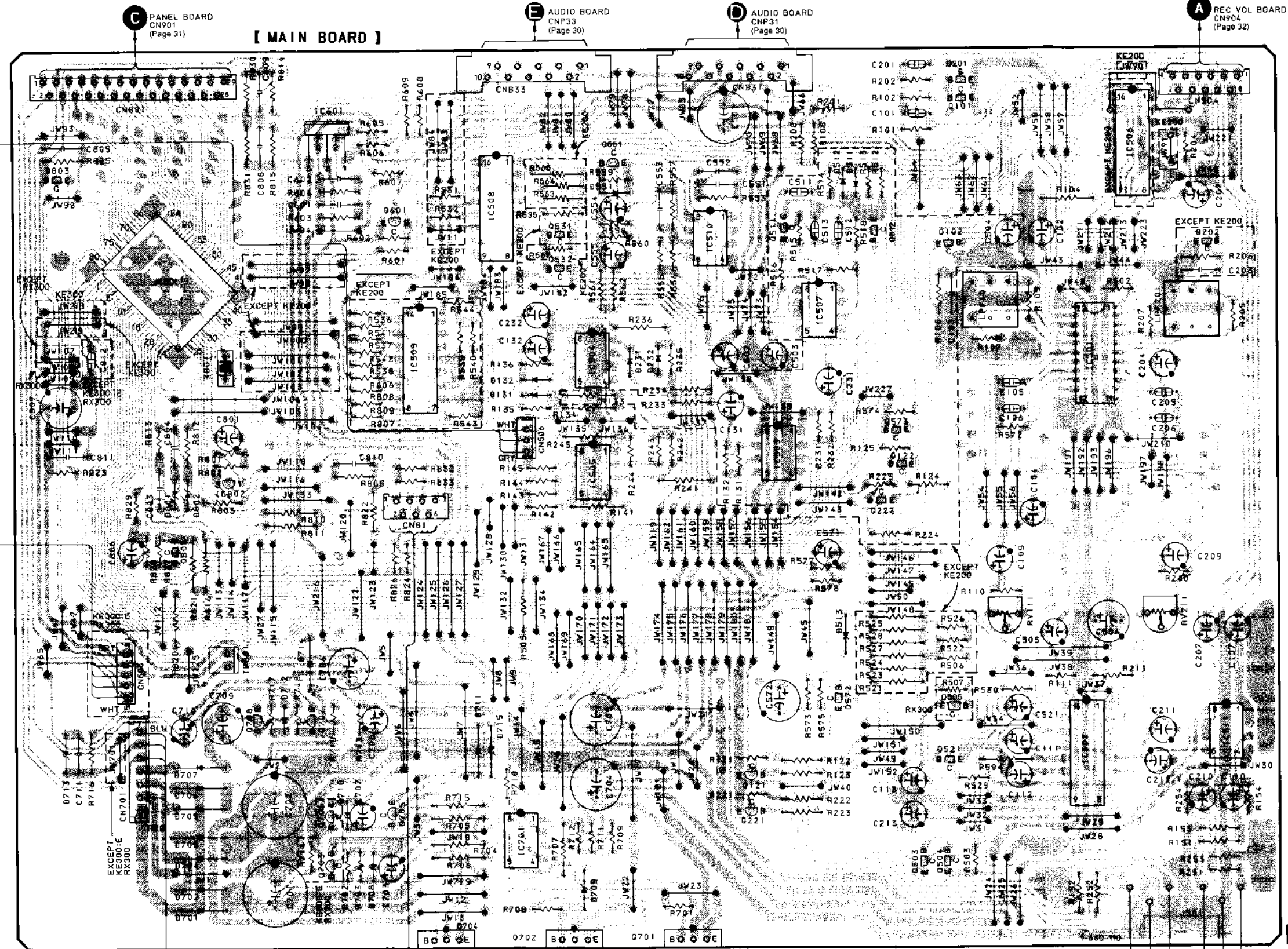
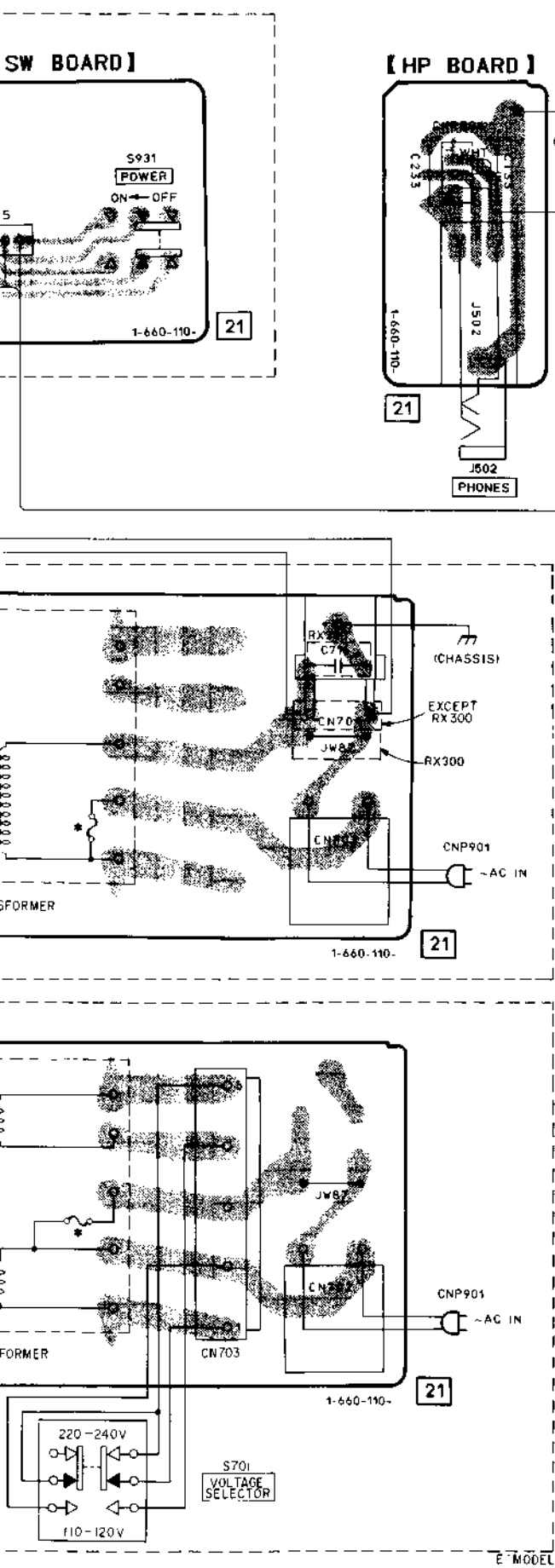

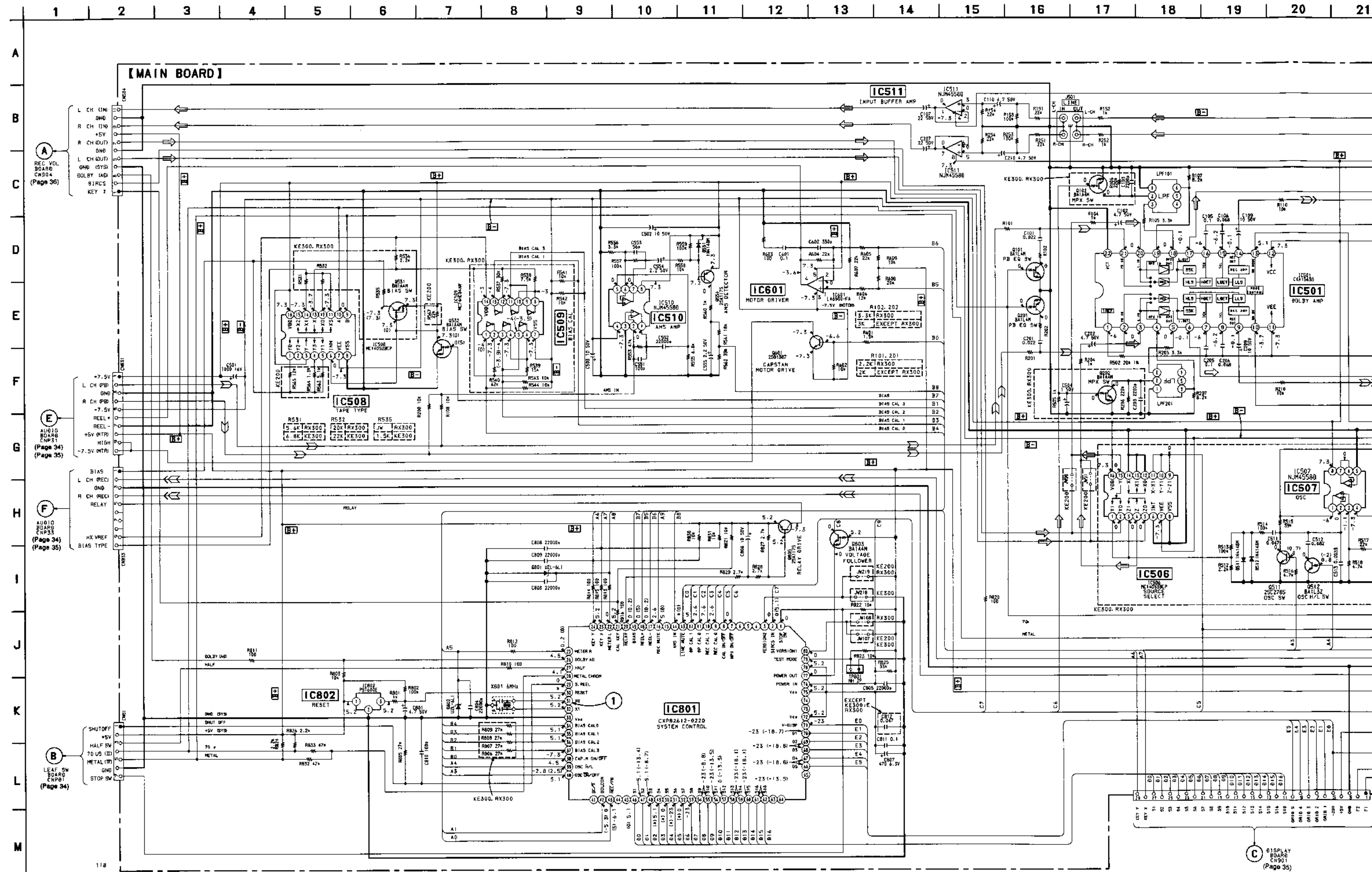

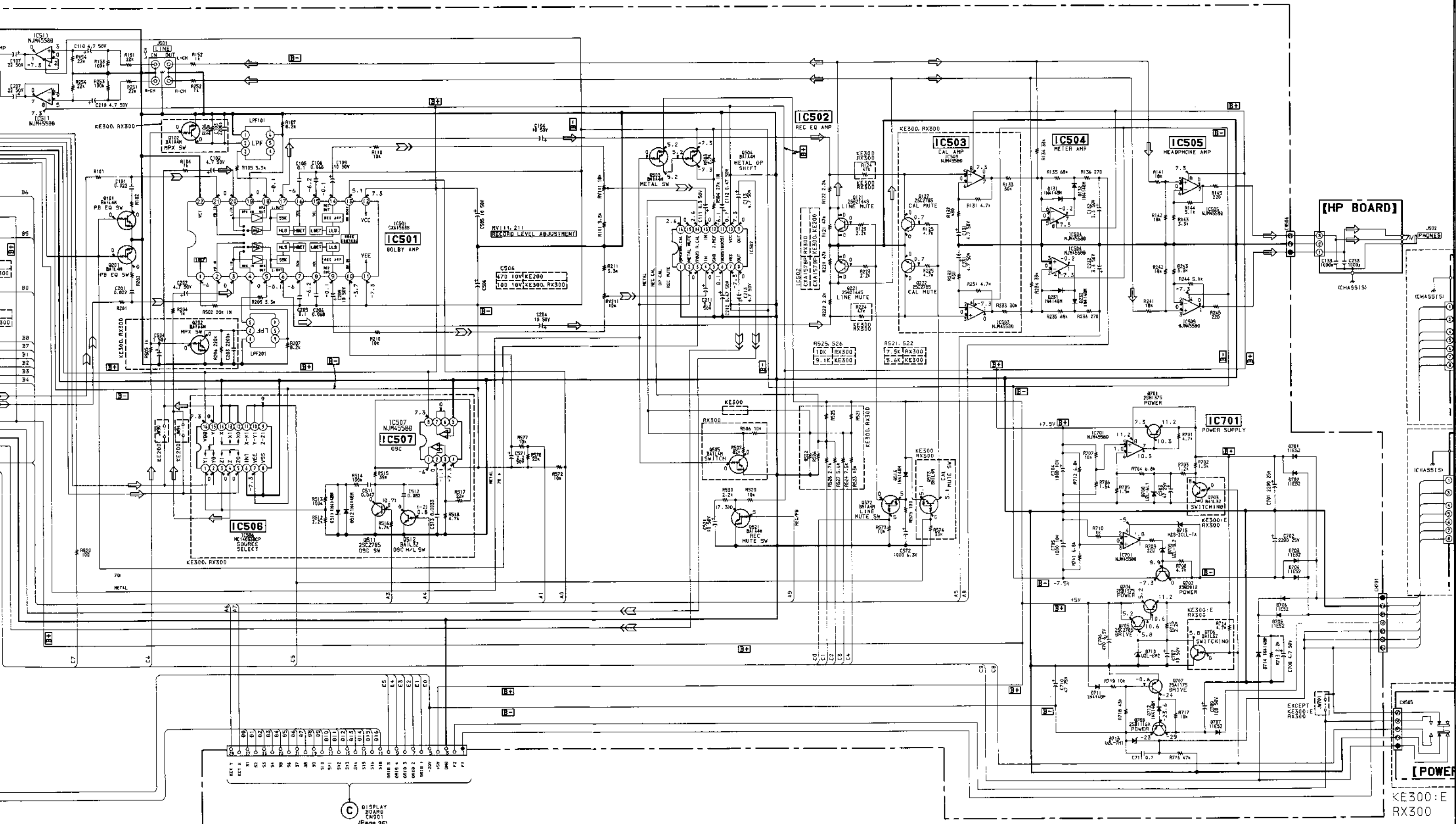

C DISPLAY BOARD CWS01 (Page 35)

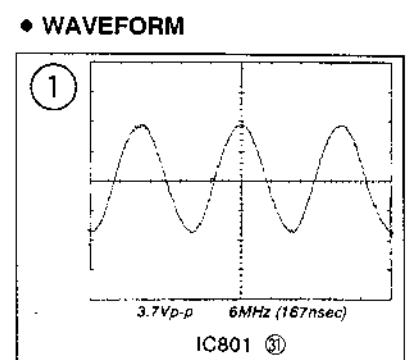
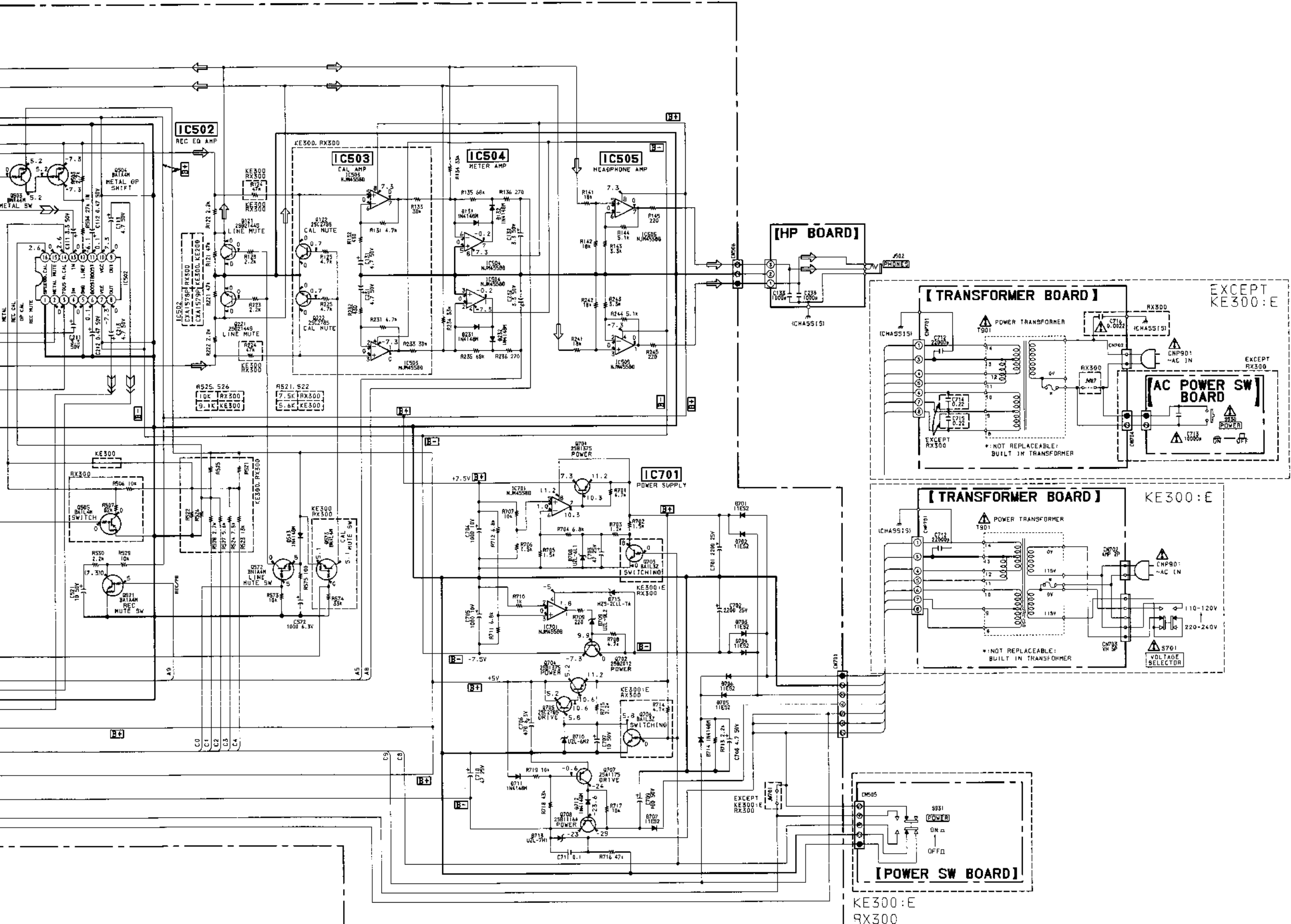

- Note :
- All capacitors are in μF unless otherwise noted. pF , μF 50V or less are not indicated except for electrolytics and tantalums.
 - All resistors are in Ω and $1/4W$ or less unless otherwise specified.
 - % : indicates tolerance.
 - Δ : internal component.
 - \square : panel designation.
 - **B+** : B+ Line
 - **B-** : B- Line
 - \square : adjustment for repair.
 - Voltage and waveforms are dc with respect to ground under no-signal conditions.
 - no mark : PLAYBACK
 - () : REC
 - * : can not be measured.
 - Voltages are taken with a VOM (Input impedance 10M Ω). Voltage variations may be noted due to normal production tolerances.
 - Waveforms are taken with a oscilloscope. Voltage variations may be noted due to normal production tolerances.
 - Circled numbers refer to waveforms.
 - Signal path.
 - \Rightarrow : LINE
 - \Rightarrow : PB
 - \Rightarrow : REC
 - Abbreviation
 - CND : Canadian

• WAVEFORM

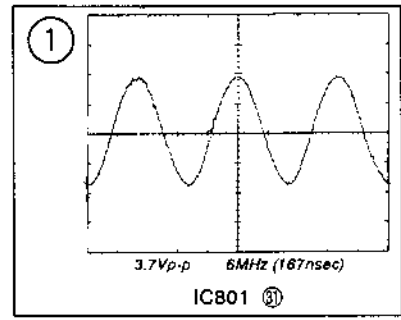

Note :

- All capacitors are in μ F unless otherwise noted. pF: μ F
- 50WV or less are not indicated except for electrolytics and tantalums.
- All resistors are in Ω and $\frac{1}{4}W$ or less unless otherwise specified.
- % : indicates tolerance.
- Δ : internal component.
- \square : panel designation.
- B+ : B+ Line
- B- : B- Line
- \square : adjustment for repair.
- Voltage and waveforms are dc with respect to ground under no-signal conditions.
- no mark : PLAYBACK
- () : REC
- * : can not be measured.
- Voltages are taken with a VOM (Input impedance 10M Ω). Voltage variations may be noted due to normal production tolerances.
- Waveforms are taken with a oscilloscope. Voltage variations may be noted due to normal production tolerances.
- Circled numbers refer to waveforms.
- Signal path.
- \Rightarrow : LINE
- \Rightarrow : PB
- \Rightarrow : REC

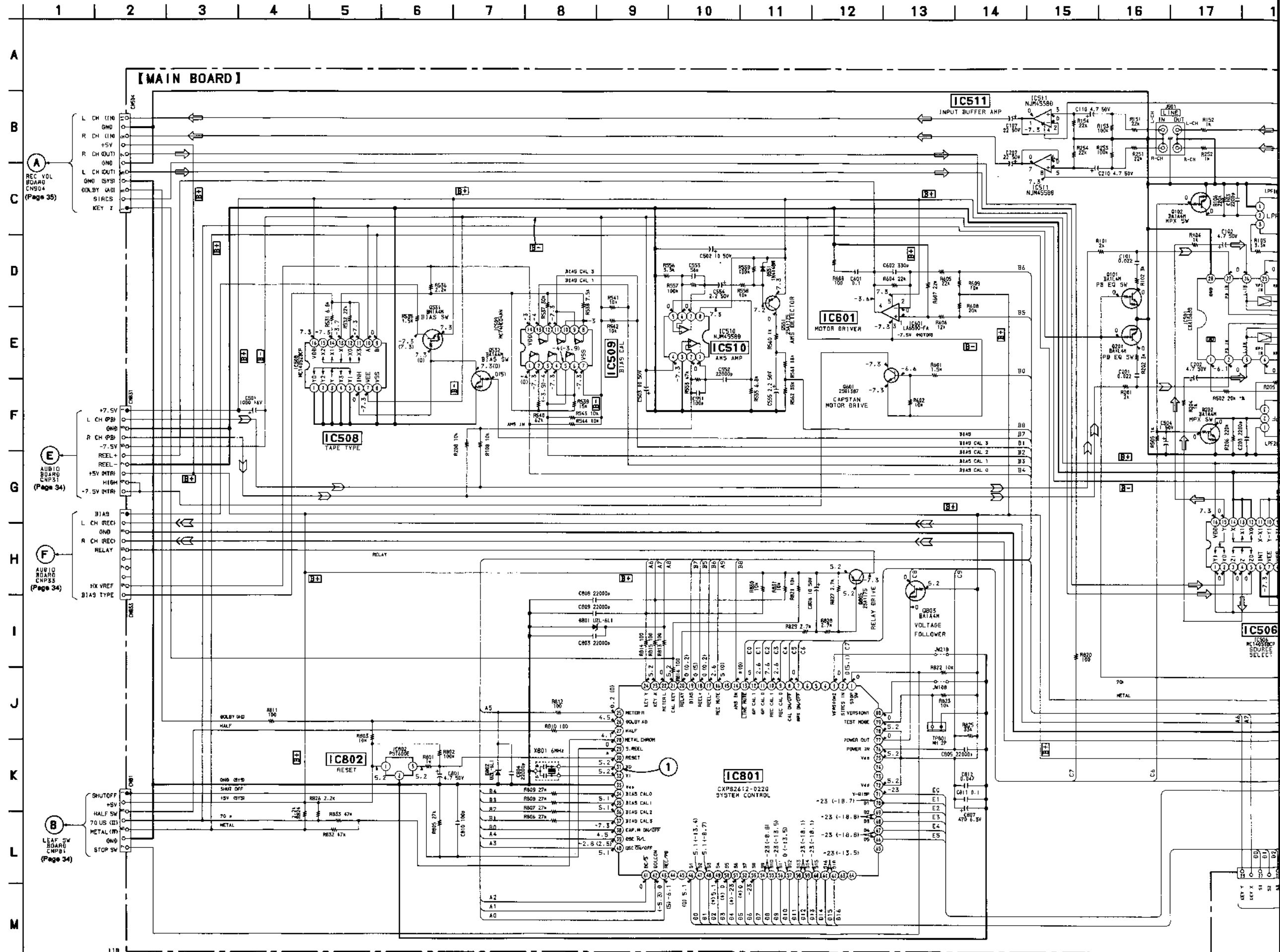

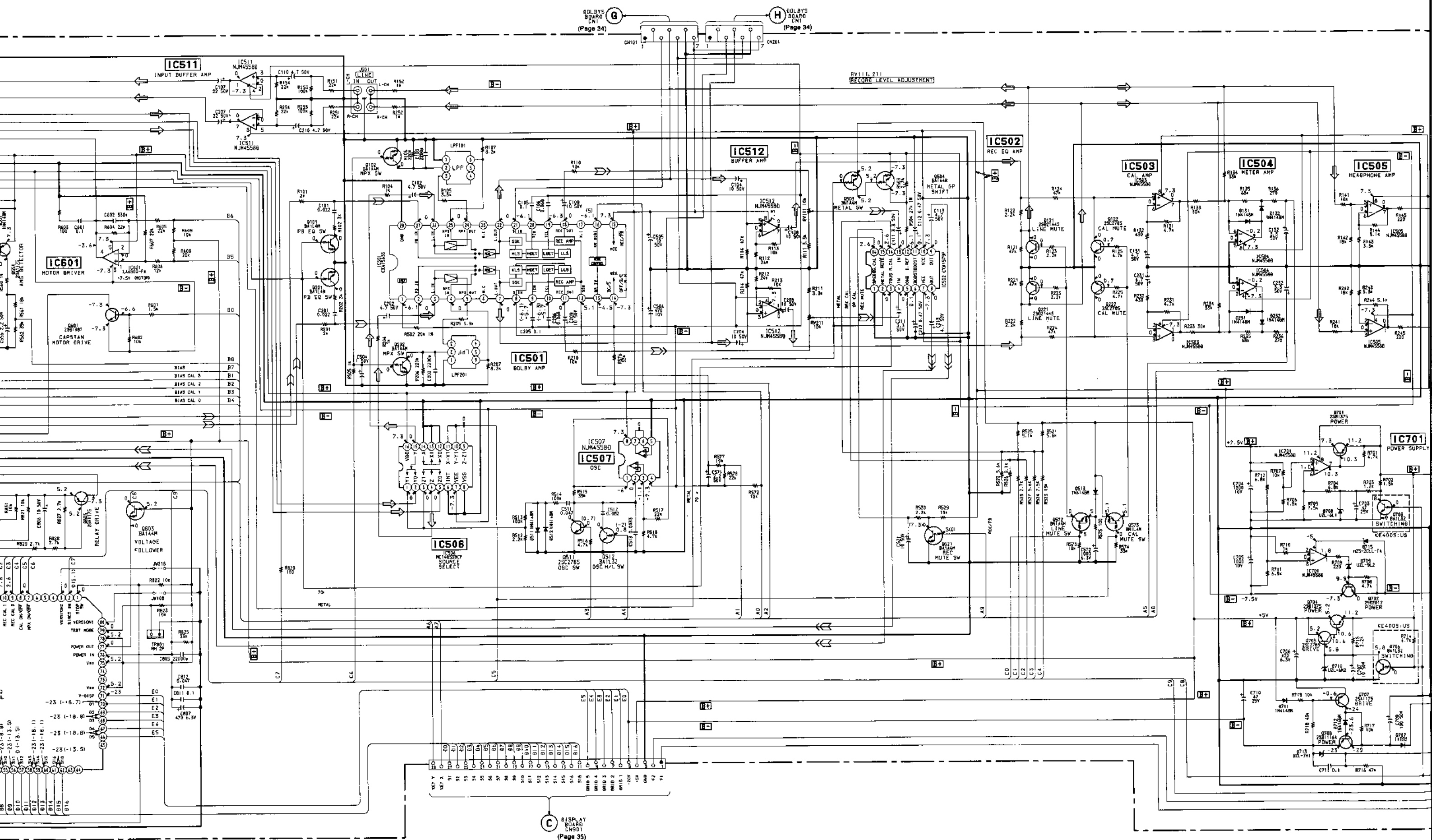

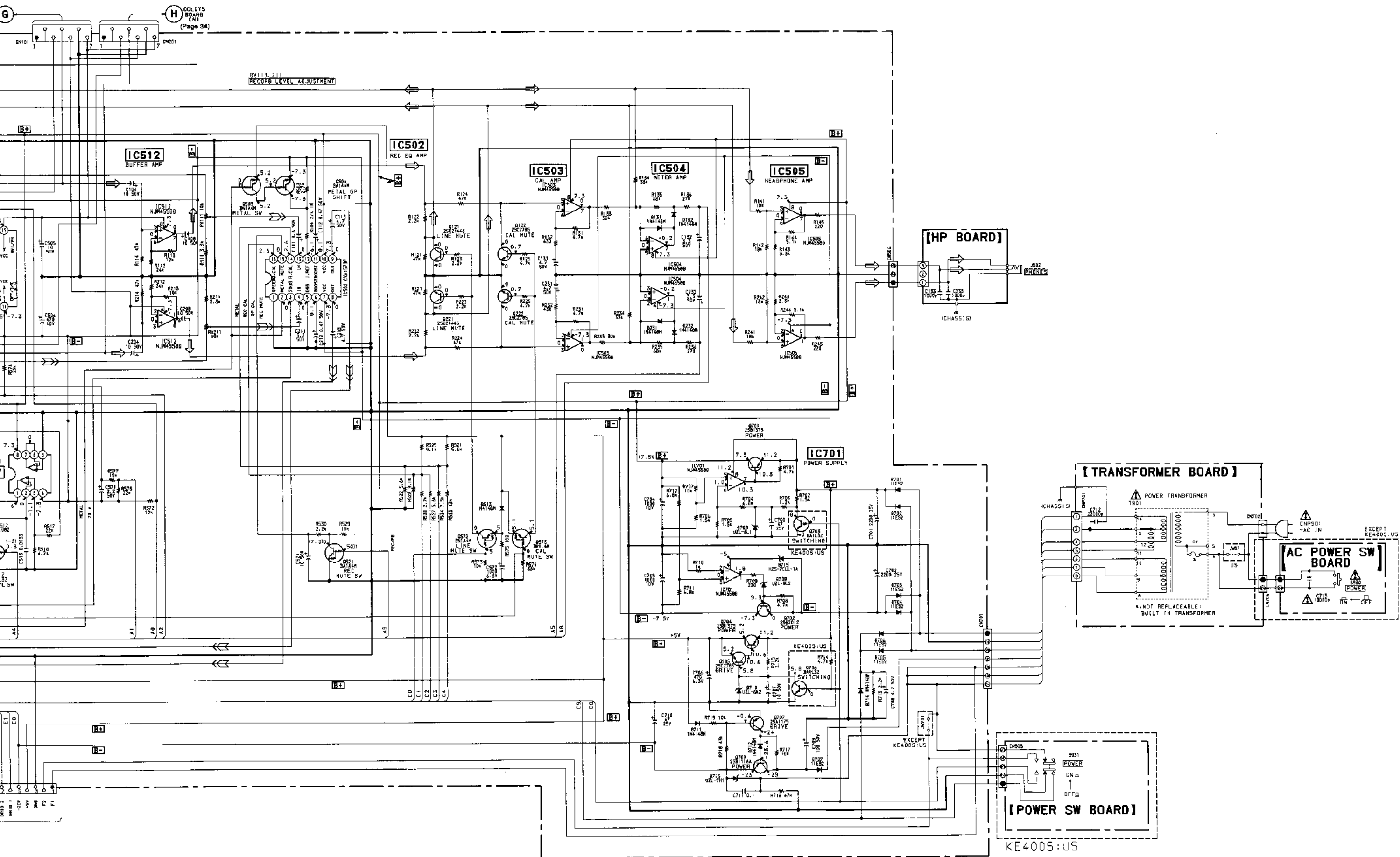

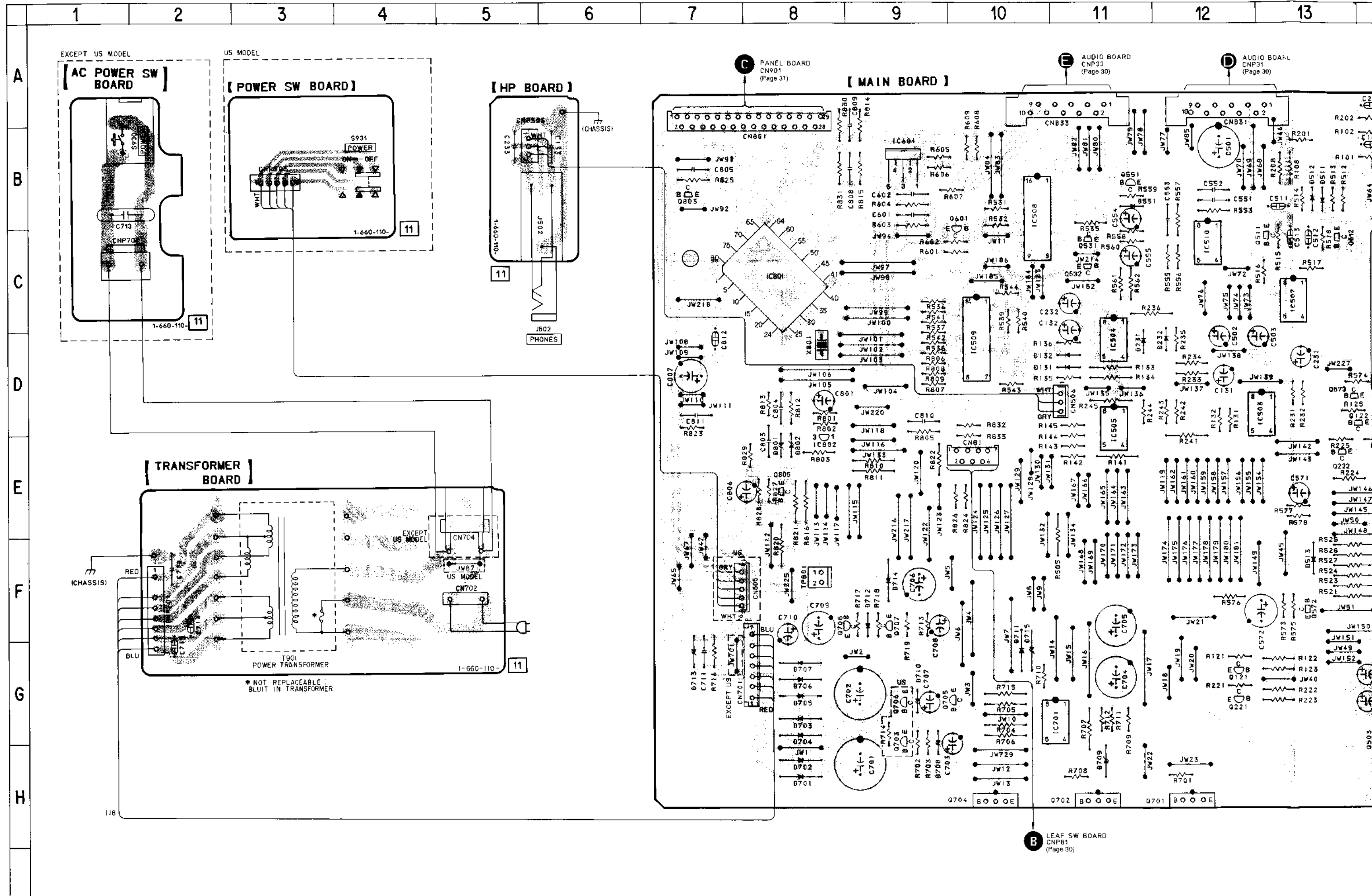

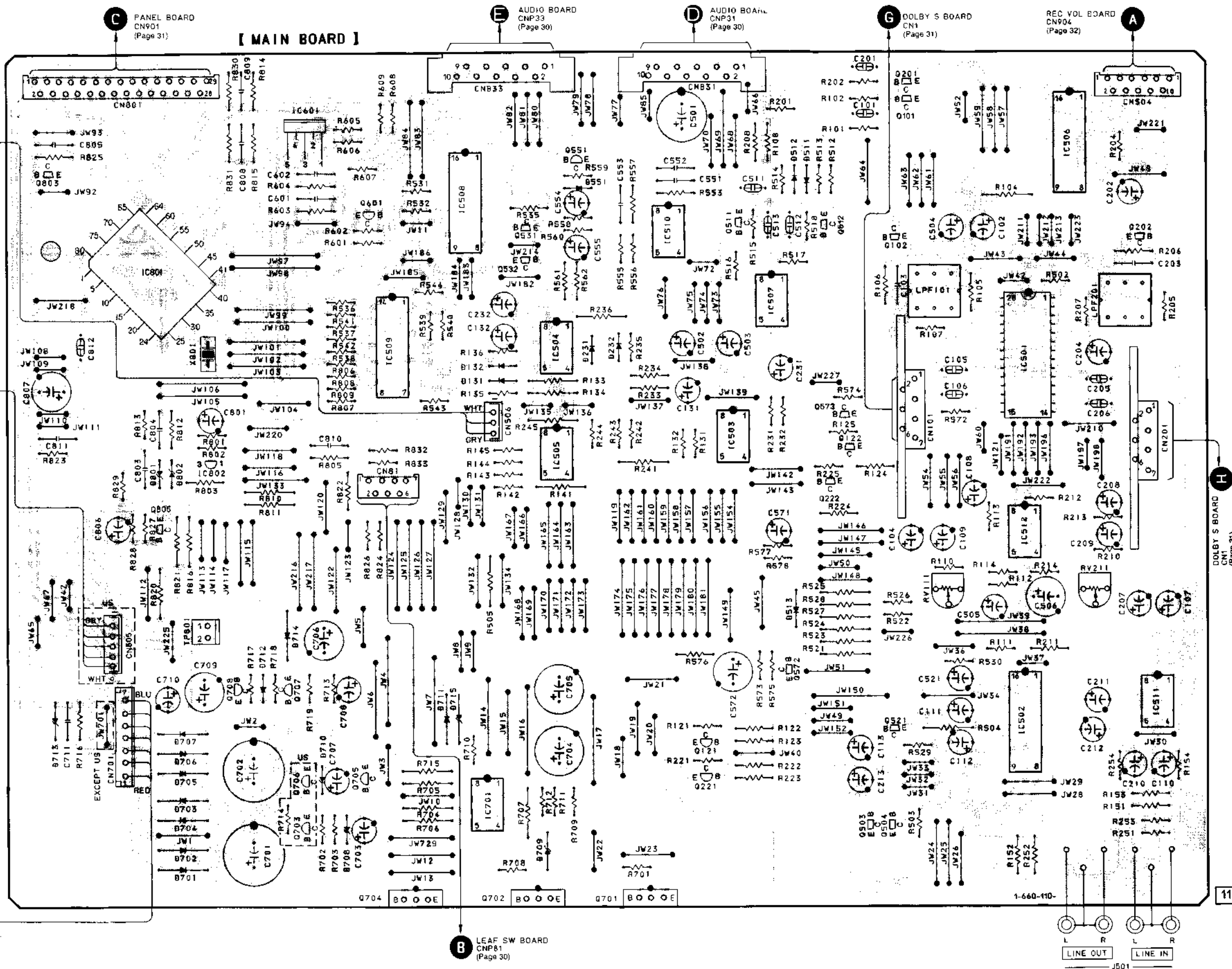

• SEMICONDUCTOR LOCATION

Ref. No.	Location	Ref. No.	Location
D131	D-11	IC512	E-15
D132	D-11	IC601	B-9
D231	D-11	IC701	G-11
D232	D-12	IC801	C-8
D511	B-13	IC802	E-8
D512	B-13	Q101	B-14
D513	F-13	Q102	C-14
D551	B-11	Q121	G-12
D701	H-8	Q122	D-13
D702	H-8	Q201	A-14
D703	G-8	Q202	C-16
D704	G-8	Q221	G-12
D705	G-8	Q222	E-13
D706	G-8	Q503	G-14
D707	G-8	Q504	G-14
D708	H-9	Q505	
D709	H-11	Q511	C-13
D710	G-9	Q512	C-13
D711	G-10	Q521	G-14
D712	F-9	Q531	C-11
D713	G-7	Q532	C-11
D714	F-9	Q551	B-11
D715	G-10	Q572	F-13
D801	E-8	Q573	D-13
D802	E-8	Q601	B-10
IC501	D-15	Q701	H-12
IC502	G-15	Q702	H-11
IC503	D-13	Q703	G-9
IC504	D-11	Q704	H-10
IC505	D-11	Q705	G-10
IC506	B-15	Q706	G-9
IC507	C-13	Q707	F-9
IC508	B-10	Q708	F-8
IC509	D-10	Q803	B-7
IC510	C-12	Q805	E-8
IC511	F-16		

Note:

- : parts extracted from the component side.
- △ : internal component.
- ▨ : Pattern from the side which enables seeing. (The other layers' patterns are not indicated)

Caution:

Pattern face side: Parts on the pattern face side seen from (Conductor Side) the pattern face are indicated.
 Parts face side: Parts on the parts face side seen from the (Component side) parts face are indicated.

TRANS

LEAF SW

PANEL

AC POWER (EXCEPT KE300: E)

IC BL

IC502
IC502

1-660-110-

J501

LINE OUT

LINE IN

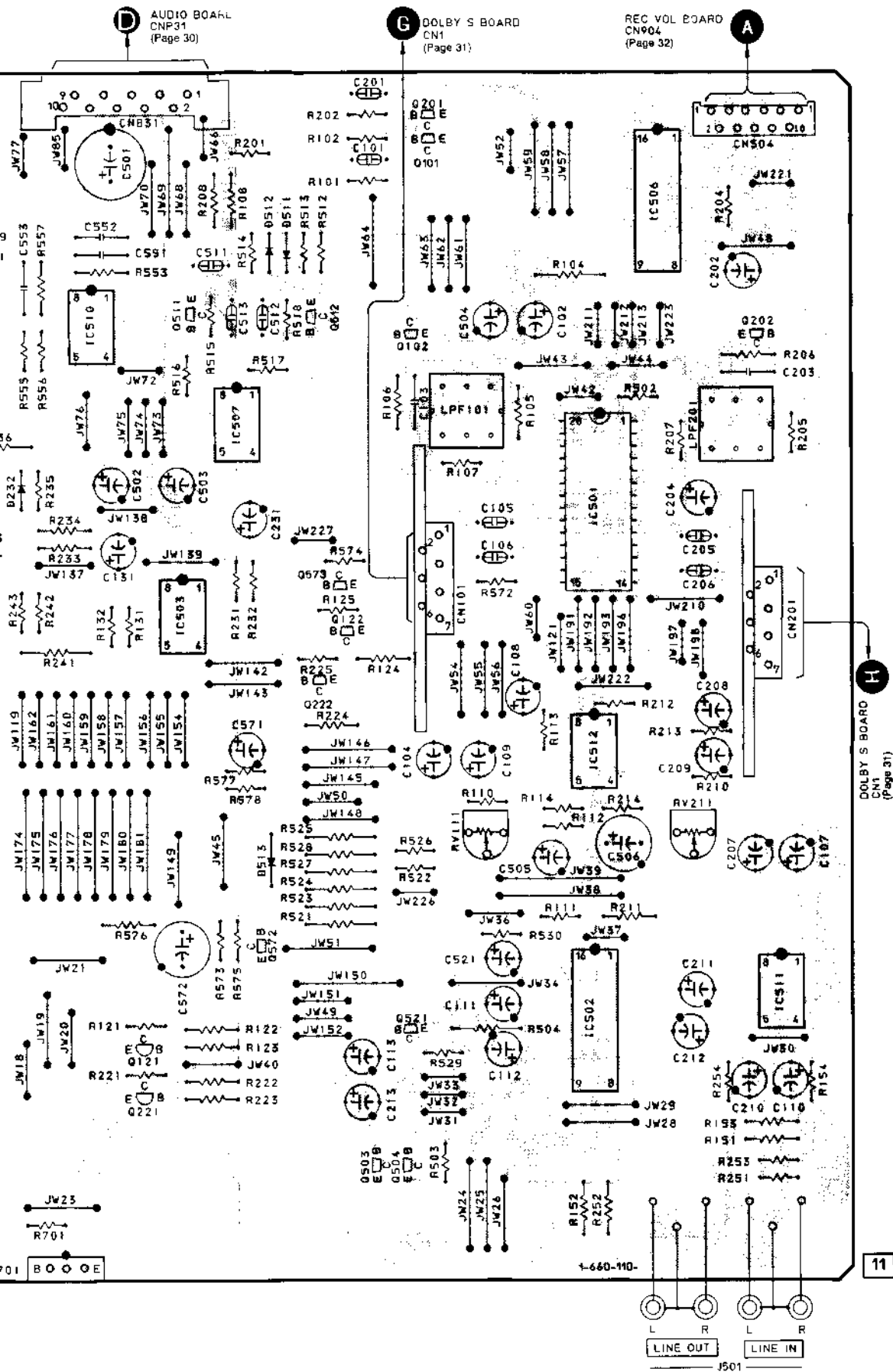

• SEMICONDUCTOR LOCATION

Ref. No.	Location	Ref. No.	Location
D131	D - 11	IC512	E - 15
D132	D - 11	IC601	B - 9
D231	D - 11	IC701	G - 11
D232	D - 12	IC801	C - 8
D511	B - 13	IC802	E - 8
D512	B - 13	Q101	B - 14
D513	F - 13	Q102	C - 14
D551	B - 11	Q121	G - 12
D701	H - 8	Q122	D - 13
D702	H - 8	Q201	A - 14
D703	G - 8	Q202	C - 16
D704	G - 8	Q221	G - 12
D705	G - 8	Q222	E - 13
D706	G - 8	Q503	G - 14
D707	G - 8	Q504	G - 14
D708	H - 9	Q505	
D709	H - 11	Q511	C - 13
D710	G - 9	Q512	C - 13
D711	G - 10	Q521	G - 14
D712	F - 9	Q531	C - 11
D713	G - 7	Q532	C - 11
D714	F - 9	Q551	B - 11
D715	G - 10	Q572	F - 13
D801	E - 8	Q573	D - 13
D802	E - 8	Q601	B - 10
IC501	D - 15	Q701	H - 12
IC502	G - 15	Q702	H - 11
IC503	D - 13	Q703	G - 9
IC504	D - 11	Q704	H - 10
IC505	D - 11	Q705	G - 10
IC506	B - 15	Q706	G - 9
IC507	C - 13	Q707	F - 9
IC508	B - 10	Q708	F - 8
IC509	D - 10	Q803	B - 7
IC510	C - 12	Q805	E - 8
IC511	F - 16		

5-5. CIRCUIT BOARDS LOCATION

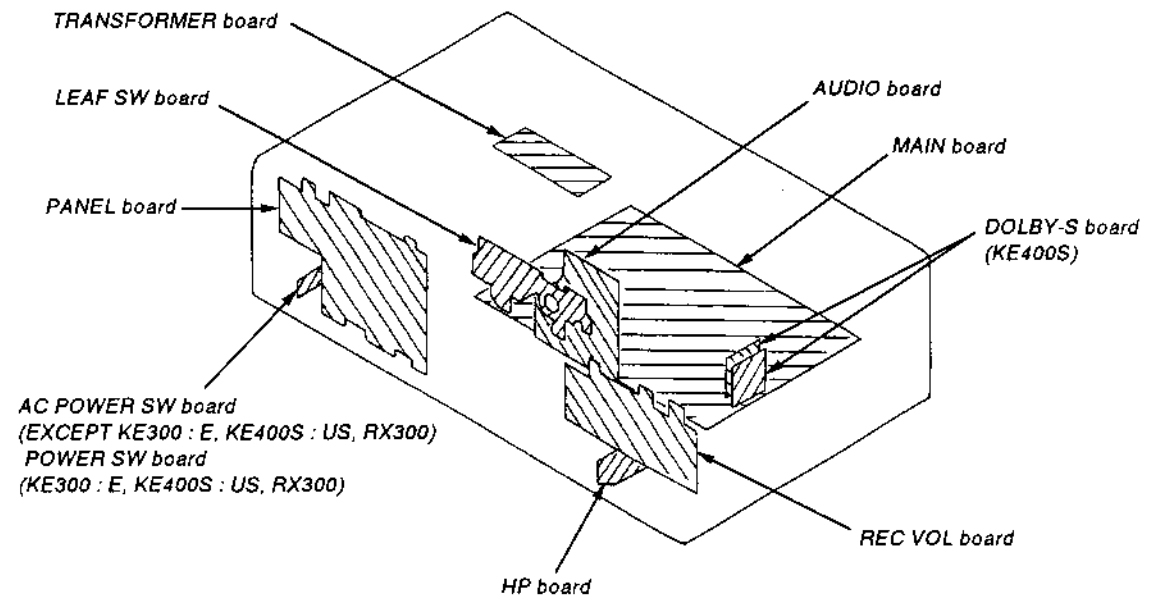

• IC BLOCK DIAGRAM

IC502 CXA1579P (EXCEPT TC-RX300)
 IC502 CXA1578P (TC-RX300 only)

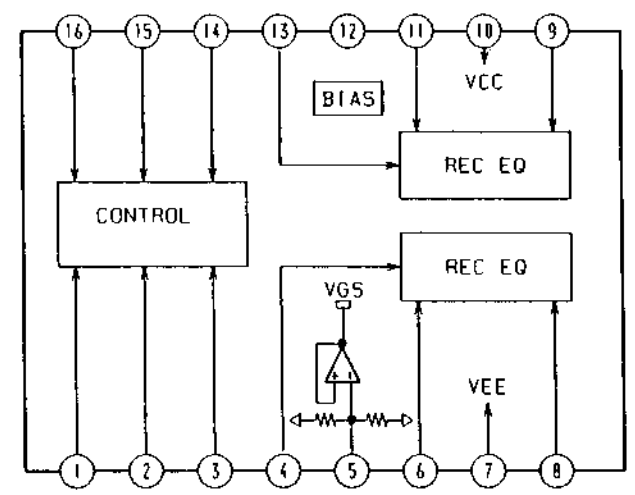

Note:
 • ○ : parts extracted from the component side.
 • △ : internal component.
 • [Pattern] : Pattern from the side which enables seeing.
 (The other layers' patterns are not indicated)

Caution:
 Pattern face side : Parts on the pattern face side seen from (Conductor Side) the pattern face are indicated.
 Parts face side : Parts on the parts face side seen from the (Component side) parts face are indicated.

● SEMICONDUCTOR LOCATION

Ref. No.	Location
D31	H - 1
IC1	I - 2
IC81	H - 7 (LEAF SW BOARD)
Q51	H - 2
Q52	G - 2
Q53	H - 2
Q71	H - 3

● SEMICONDUCTOR LOCATION

Ref. No.	Location
D31	C - 1
IC1	G - 16 (KE400S)
IC31	C - 2
IC81	B - 3 (AUDIO BOARD)
IC81	H - 7 (LEAF SW BOARD)
IC901	B - 23 (KE400S)
IC901	G - 23 (KE200/KE300/RX300)
Q51	B - 2
Q52	B - 2
Q53	B - 1
Q71	C - 3

Note:

- : parts extracted from the component side.
- ⊙ : Pattern from the side which enables seeing.
(The other layers' patterns are not indicated)

Caution :

Pattern face side : Parts on the pattern face side seen from (Conductor Side) the pattern face are indicated.
Parts face side : Parts on the parts face side seen from the (Component side) parts face are indicated.

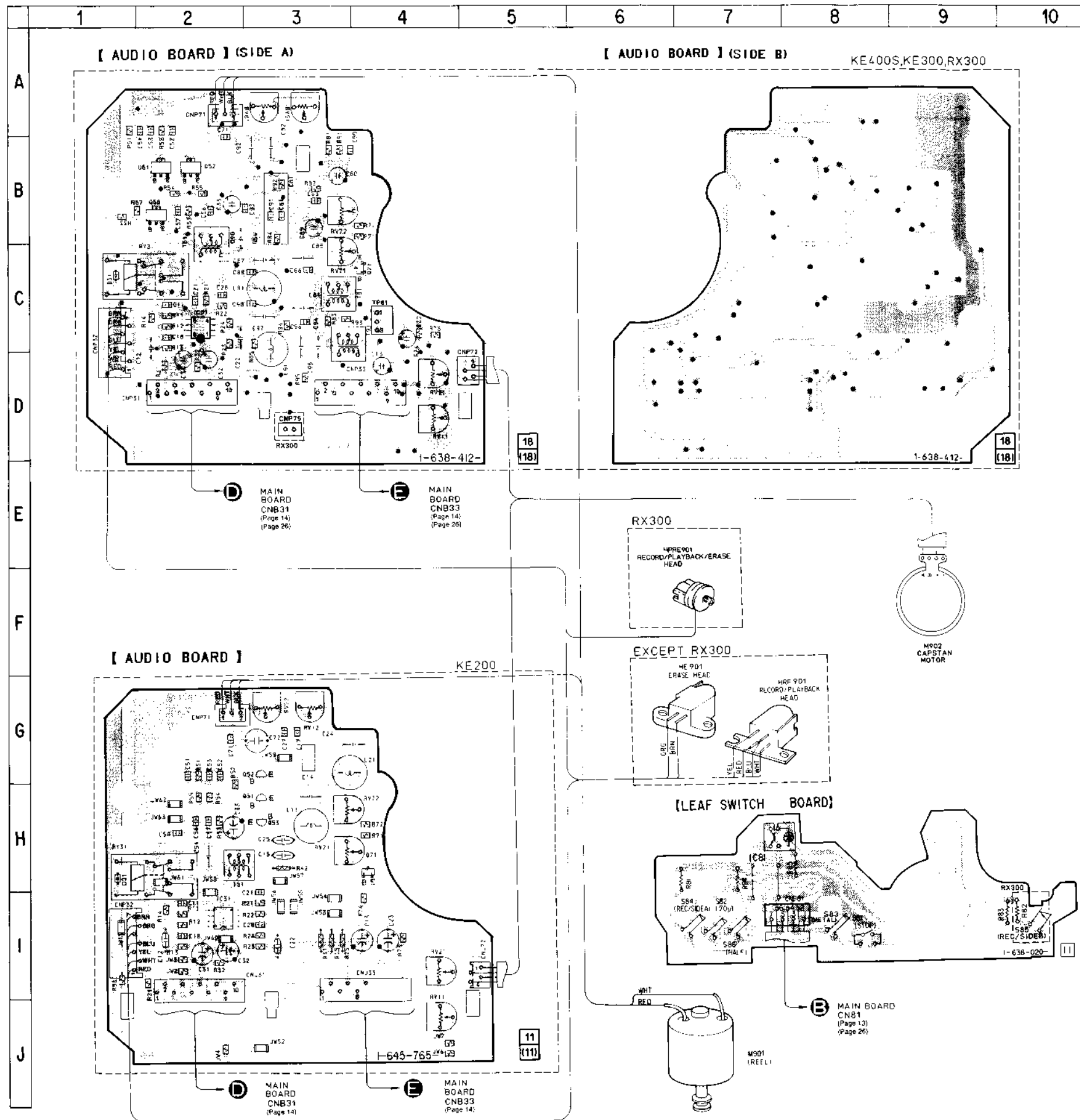

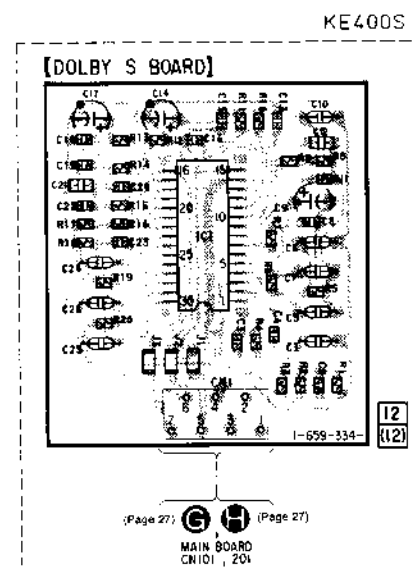
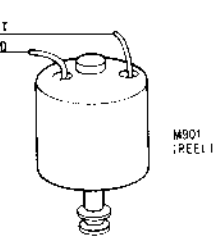
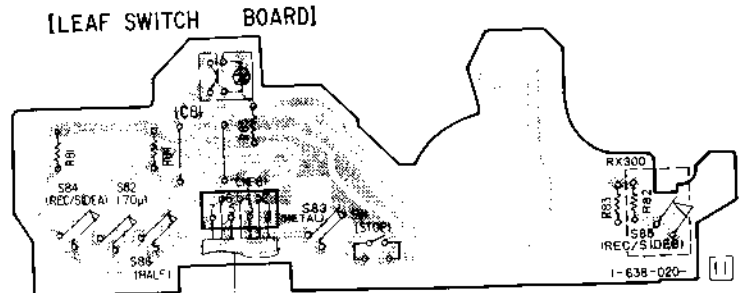
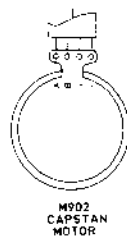
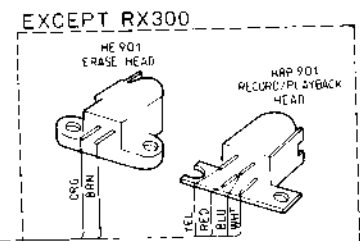
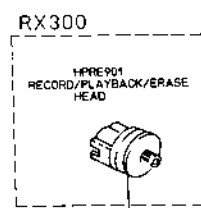
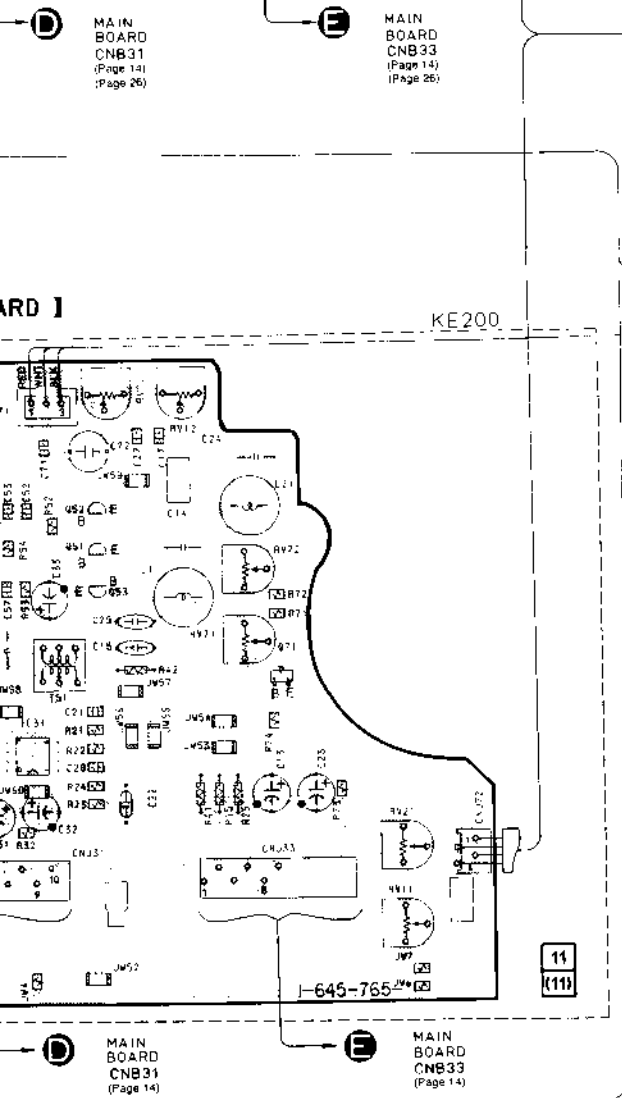
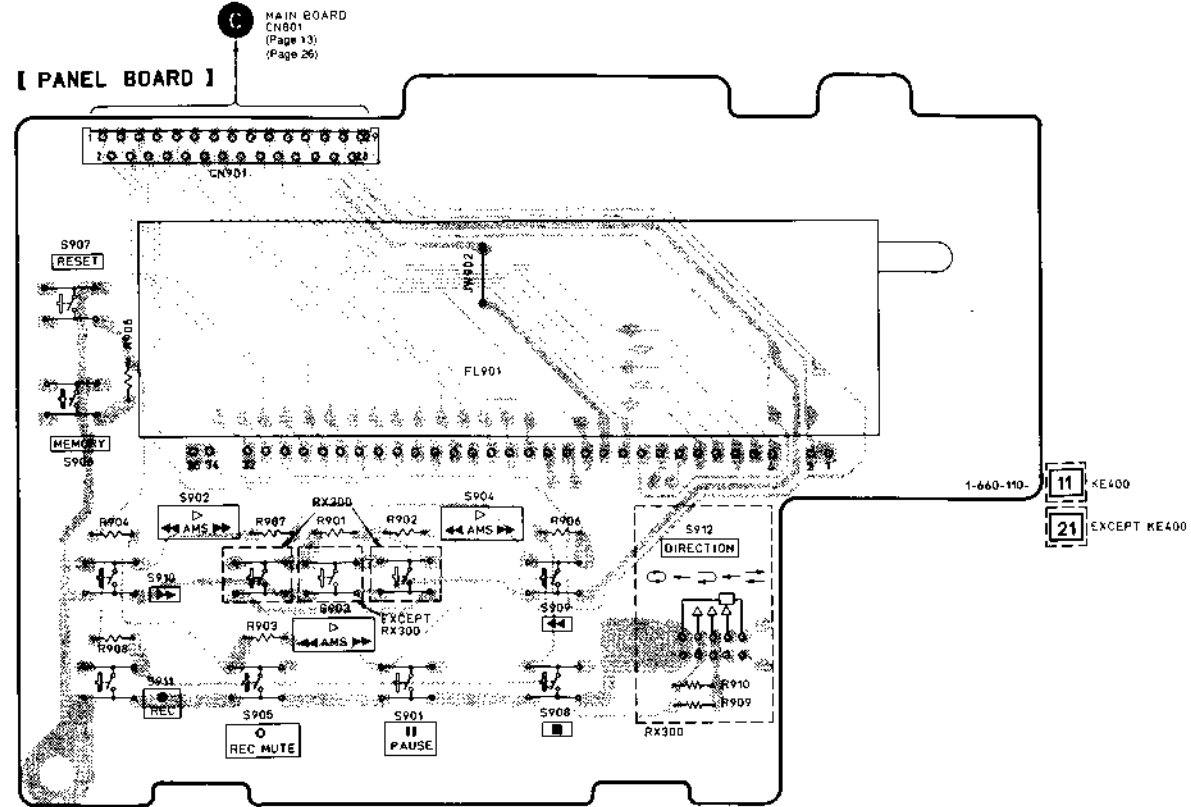
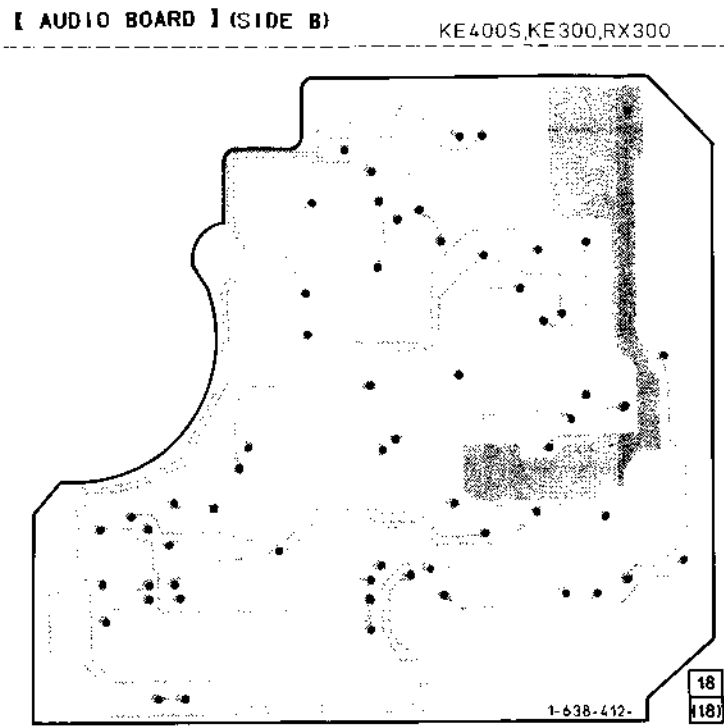
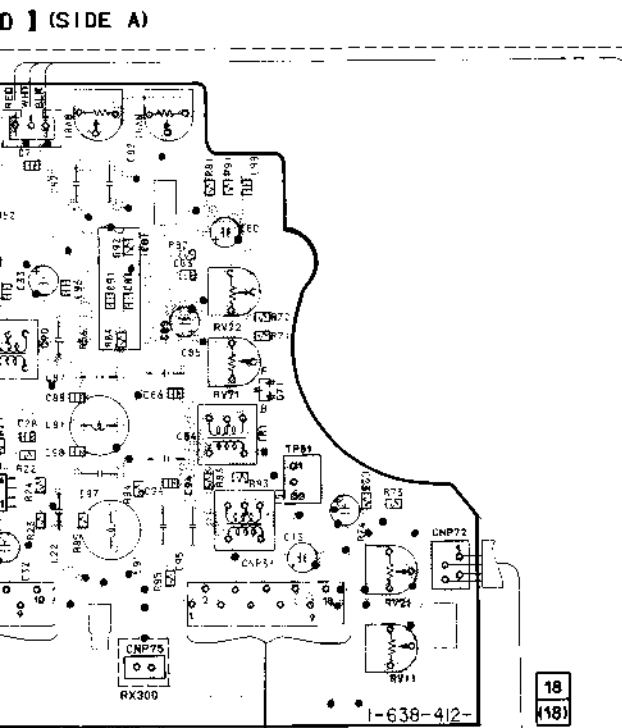

KE400S, KE300, RX300

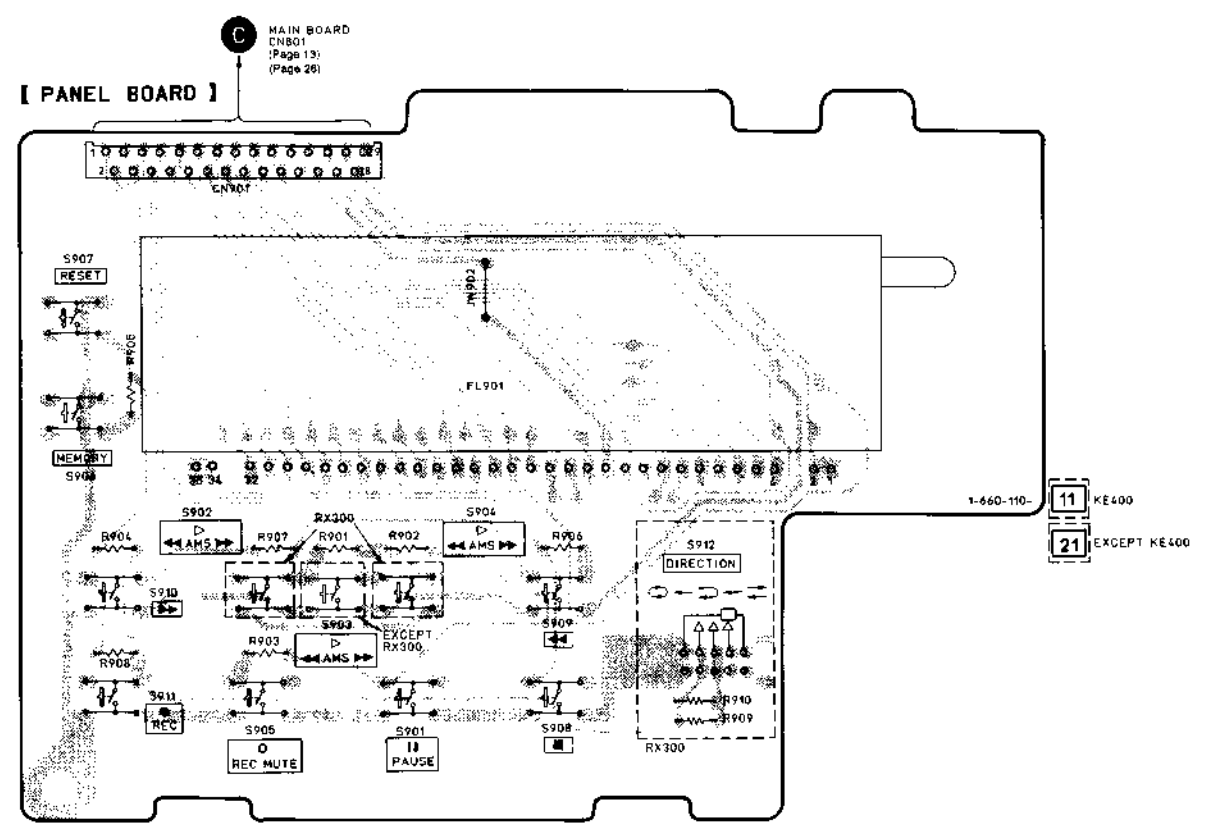
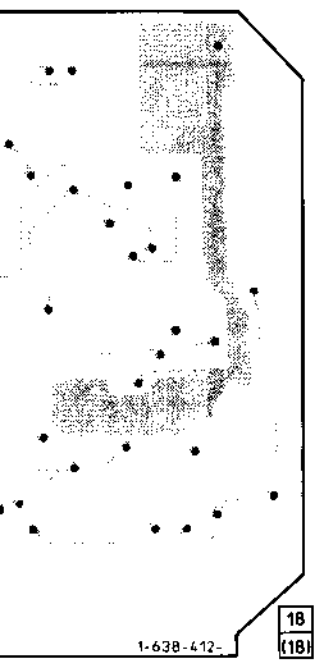

1-660-110-11 KE400
21 EXCEPT KE400

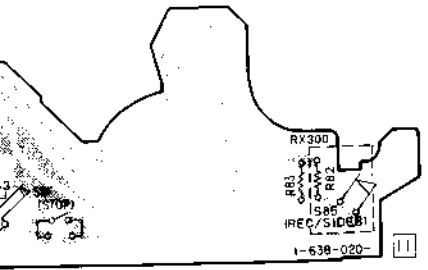
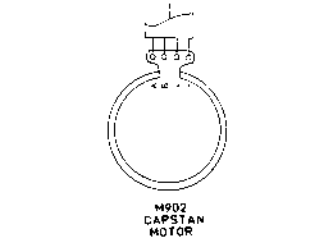

MAIN BOARD
CN81
(Page 13)
(Page 26)

KE400S

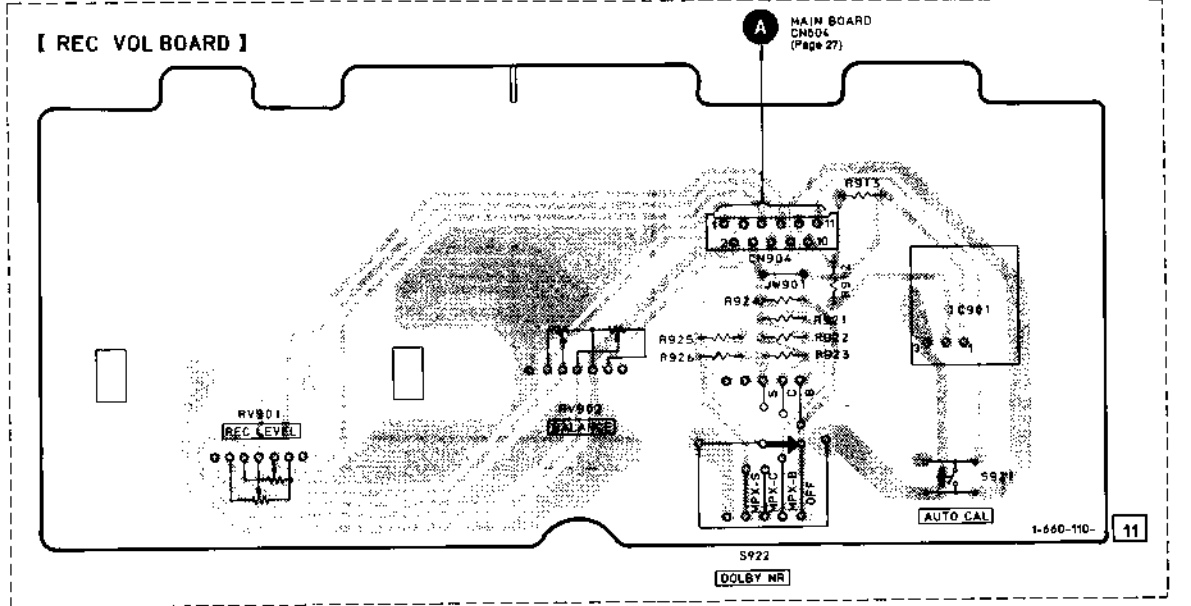

1-660-110-11

KE300, RX300, KE200

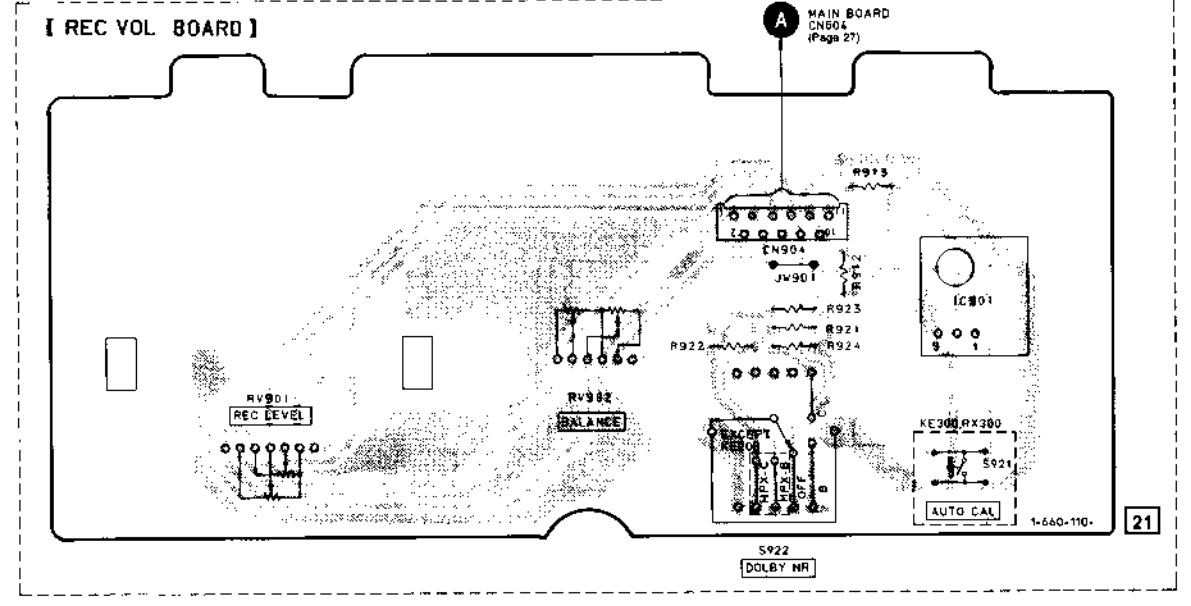

1-660-110-21

KE400S

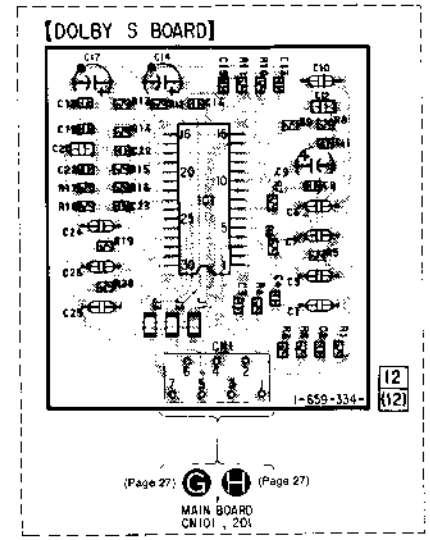

1-659-334-12
12

(Page 27) G (Page 27)
MAIN BOARD
CN101, 201

5-7. SCHEMATIC DIAGRAM - AUDIO SECTION -

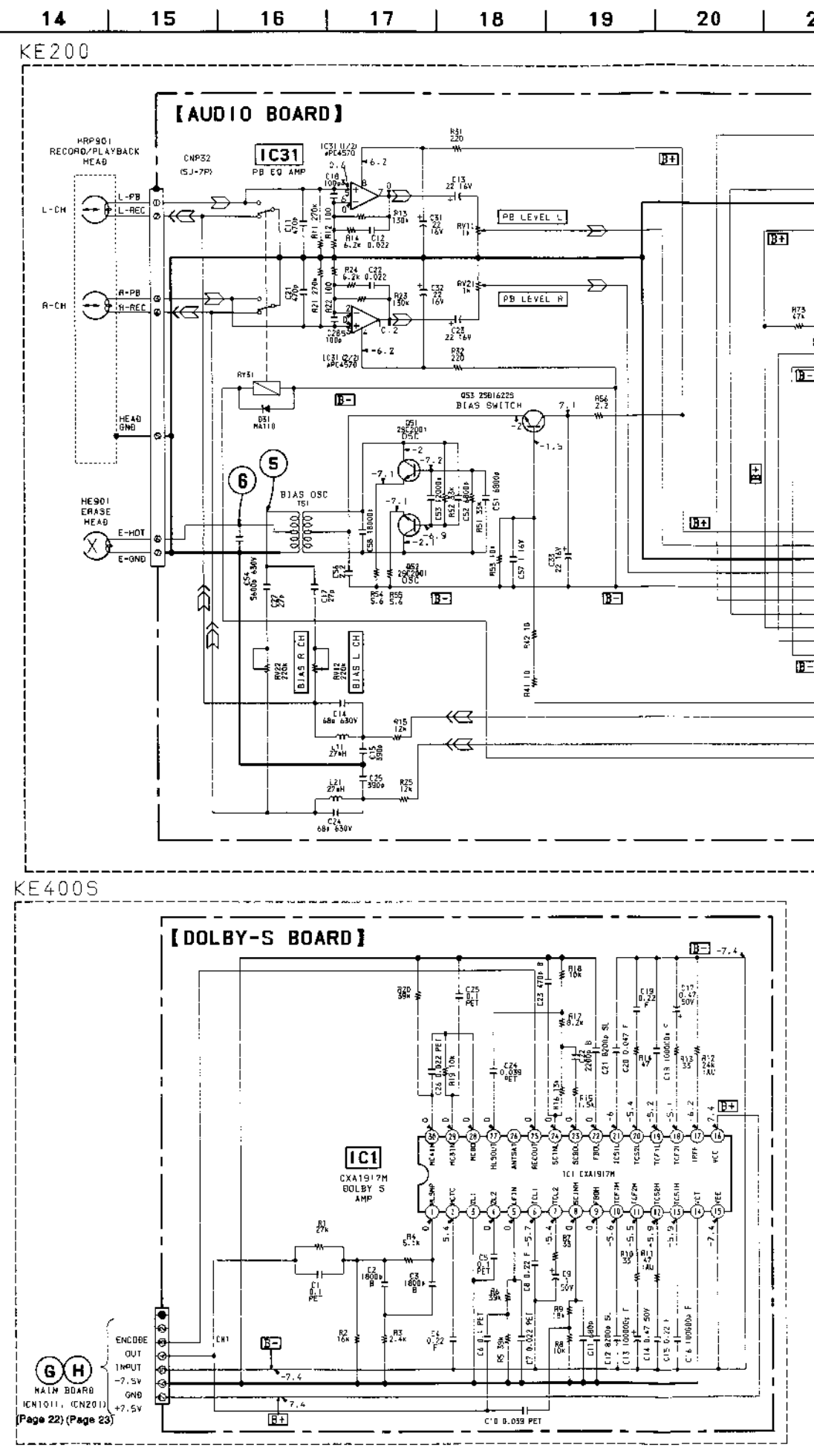
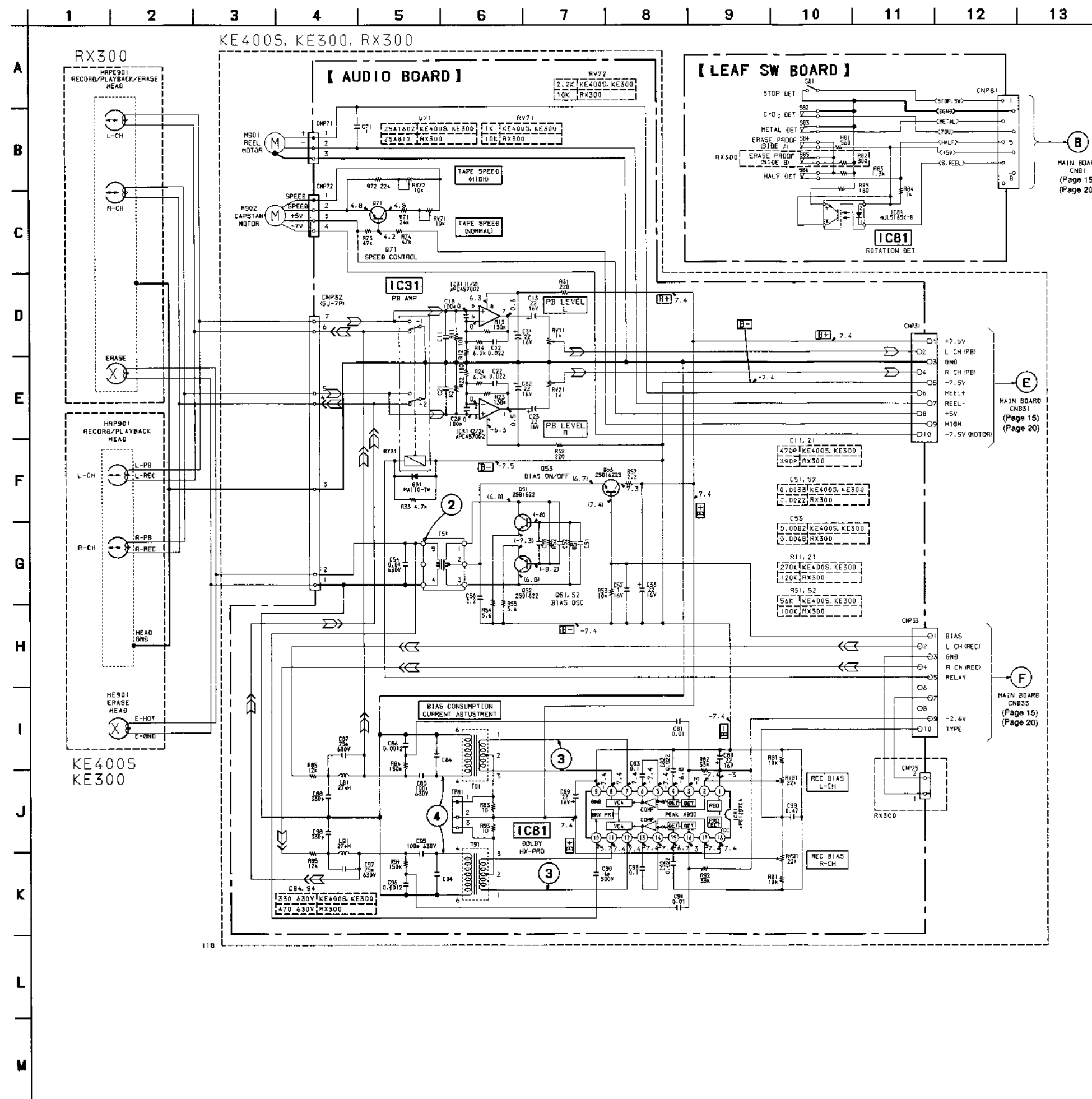

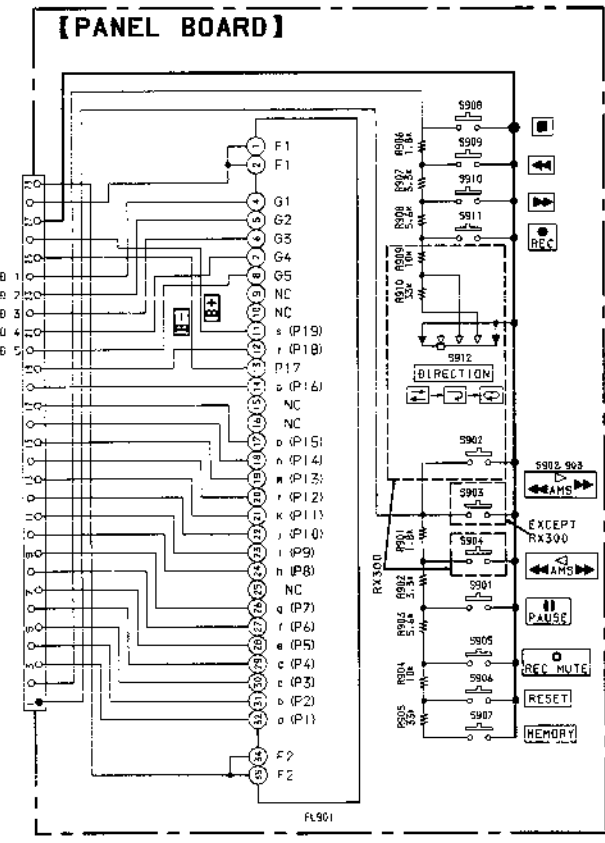
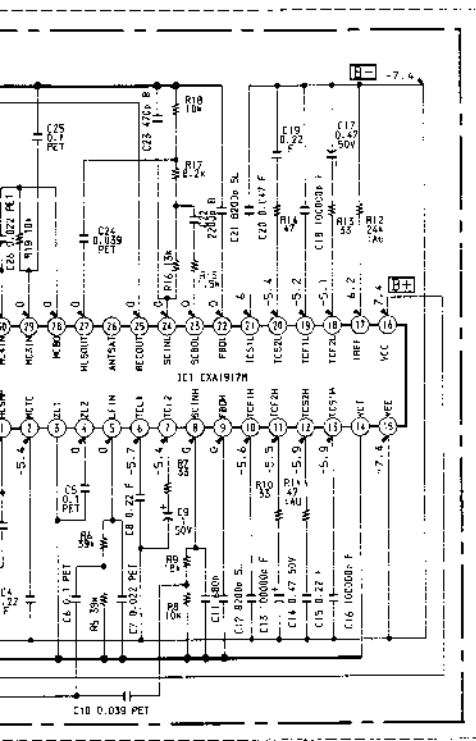
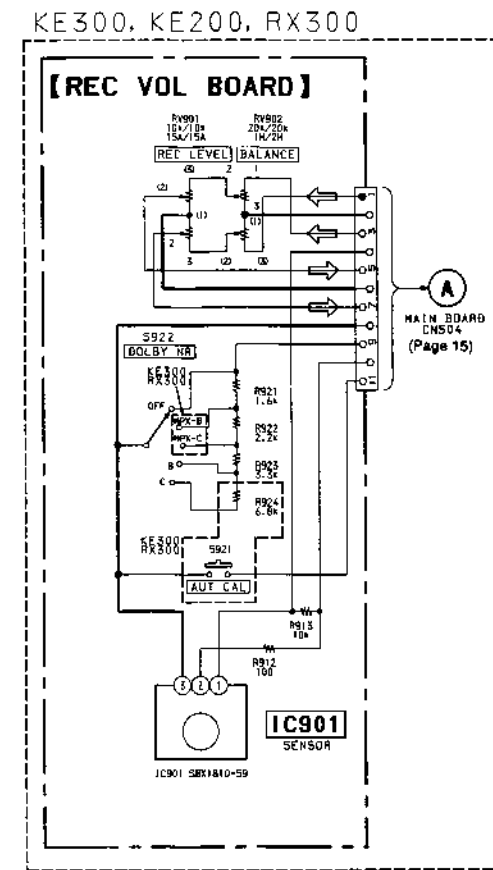
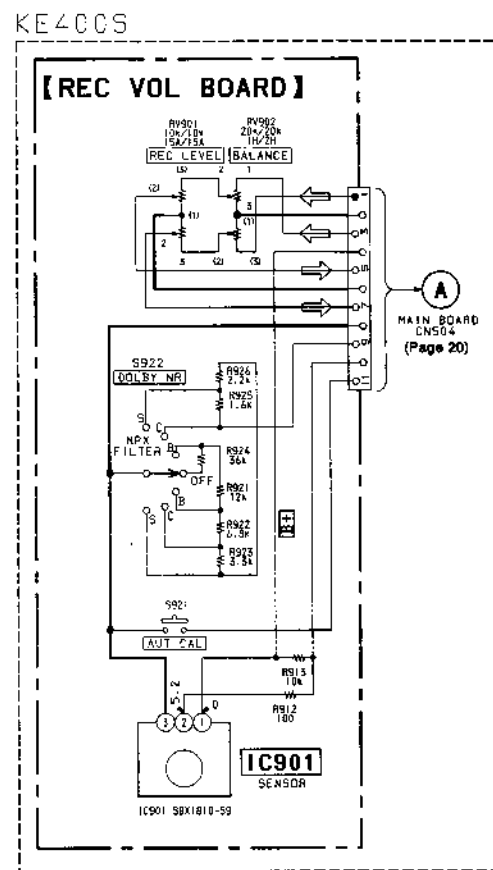
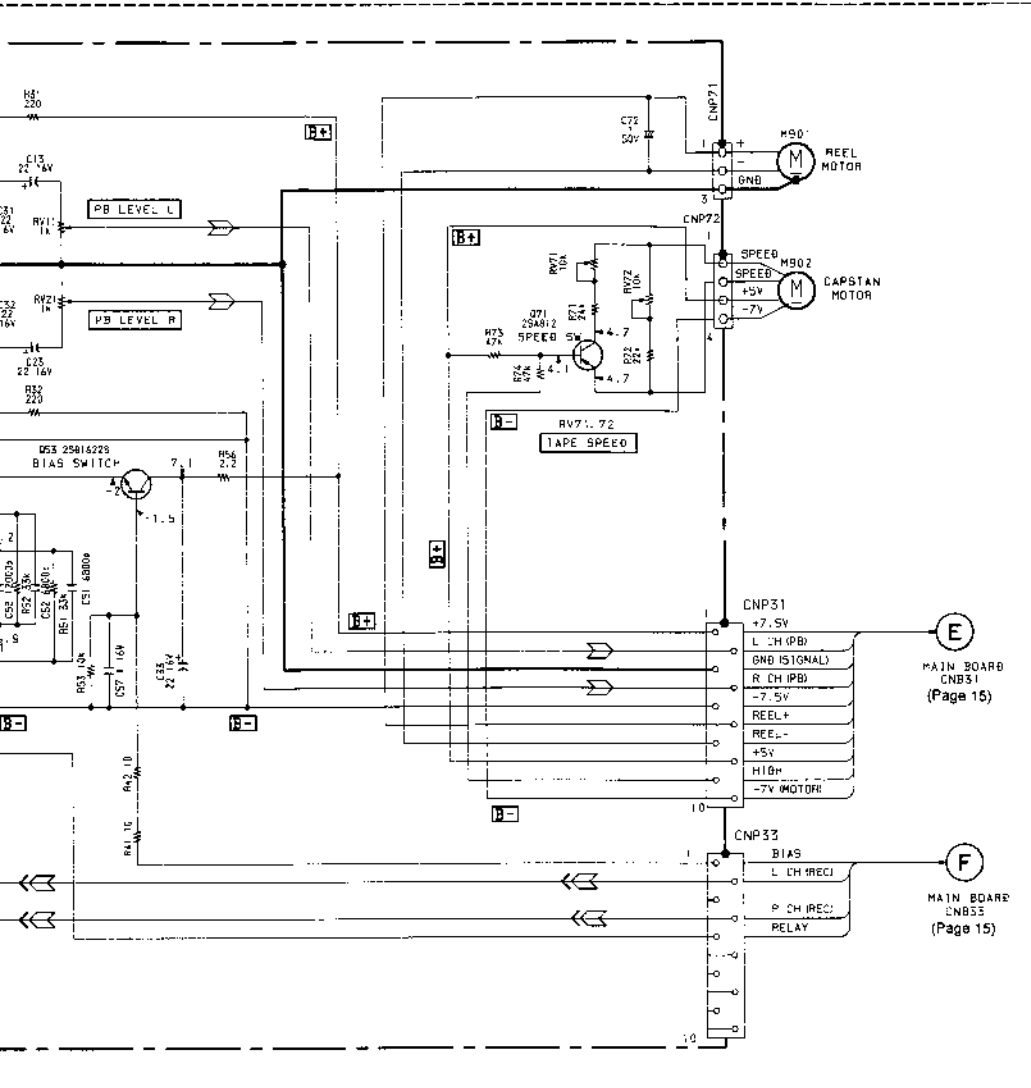

• WAVEFORMS

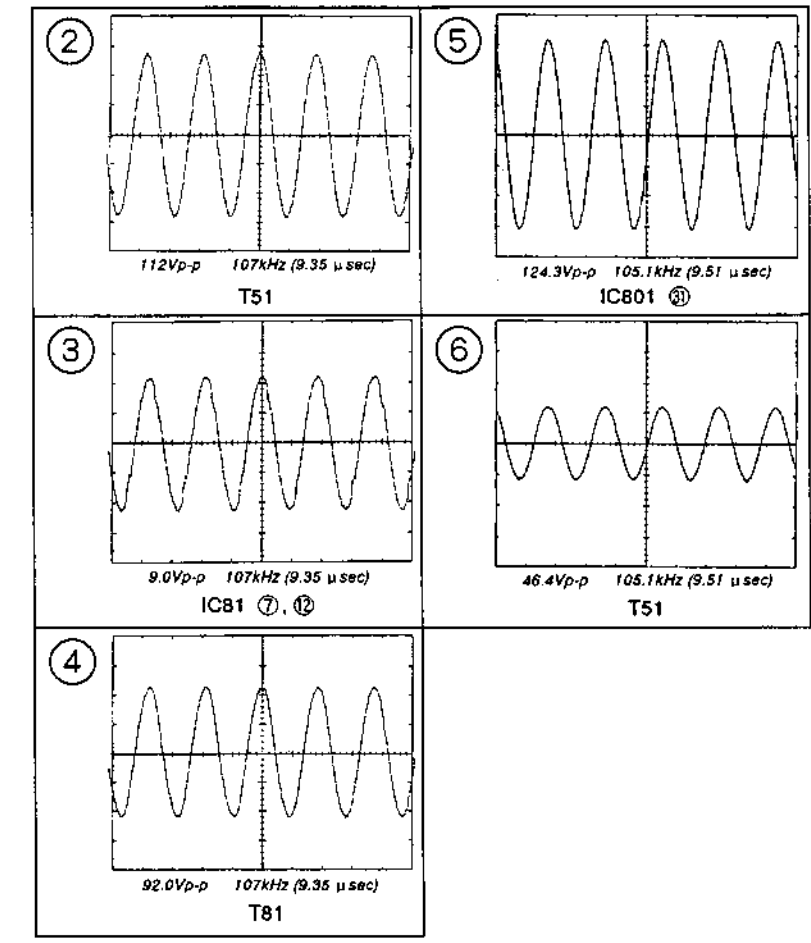

Note :

- All capacitors are in μF unless otherwise noted. $pF: \mu \mu F$ 50WV or less are not indicated except for electrolytics and tantalums.
- All resistors are in Ω and $\frac{1}{4}W$ or less unless otherwise specified.
- : panel designation.

Note :
The components identified by mark \blacktriangle or dotted line with mark \blacktriangle are critical for safety. Replace only with part number specified.

Note :
Les composants identifiés par une marque \blacktriangle sont critiques pour la sécurité. Ne les remplacer que par une pièce portant le numéro spécifié.

- **B+** : B+ Line
- **B-** : B- Line
- : adjustment for repair.
- Voltage and waveforms are dc with respect to ground under no-signal conditions.
- Voltages are taken with a VOM (Input impedance 10M Ω). Voltage variations may be noted due to normal production tolerances.
- Waveforms are taken with a oscilloscope. Voltage variations may be noted due to normal production tolerances.
- Circled numbers refer to waveforms.
- Signal path.
 : PB
 : REC

SECTION 6 EXPLODED VIEWS

NOTE :

- -XX, -X mean standardized parts, so they may have some difference from the original one.
- Items marked " * " are not stocked since they are seldom required for routine service. Some delay should be anticipated when ordering these items.

- The mechanical parts with no reference number in the exploded views are not supplied.
- Hardware (# mark) list and accessories and packing materials are given in the last of this parts list.
- Abbreviation
 CND : Canadian SP : Singapore
 AUS : Australian MY : Malaysia
 G : German

The components identified by mark Δ or dotted line with mark Δ are critical for safety.
 Replace only with part number specified.

Les composants identifiés par une marque Δ sont critiques pour la sécurité.
 Ne les remplacer que par une pièce portant le numéro spécifié.

6-1. CHASSIS SECTION

Δ A : TRANS board

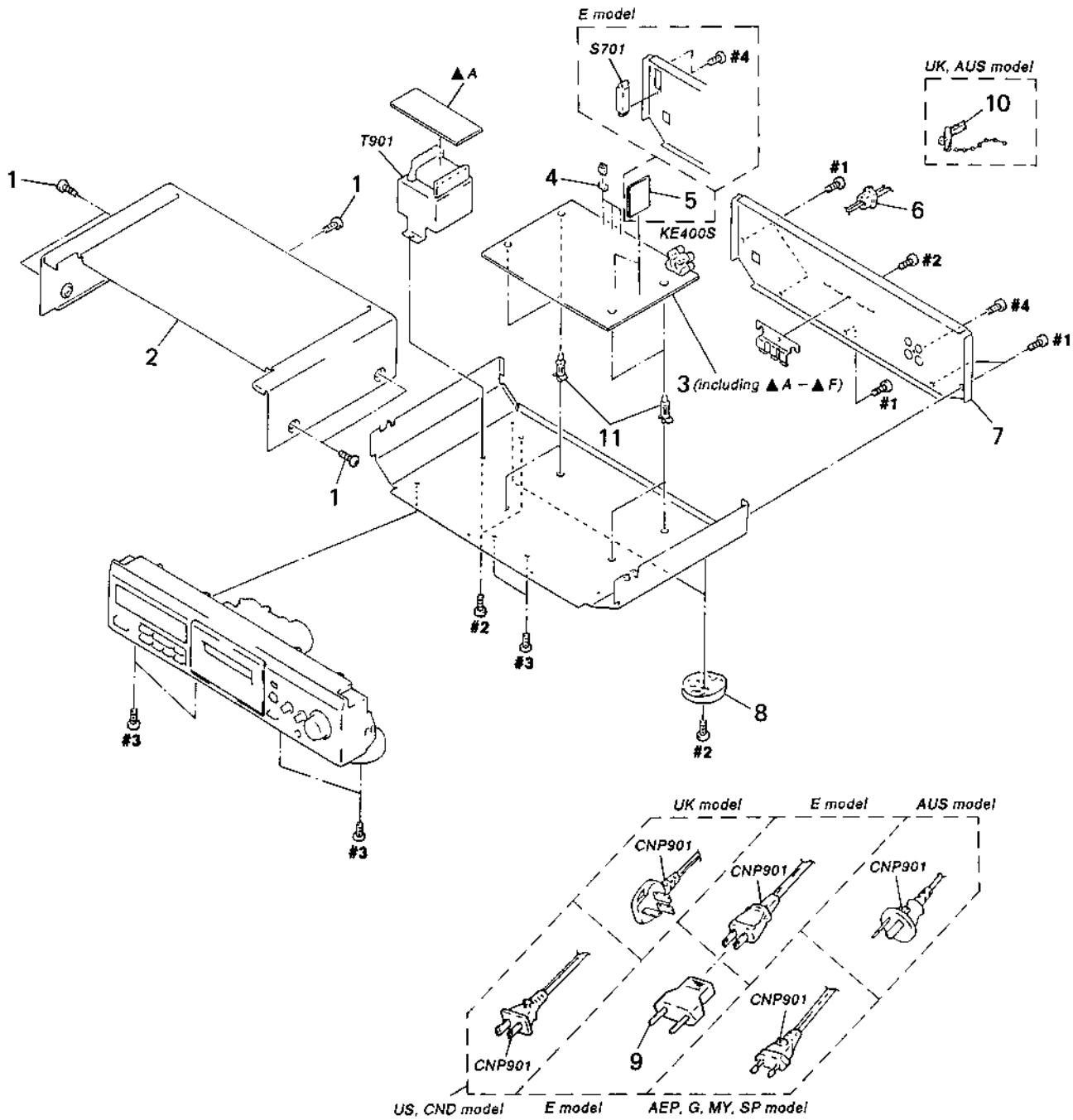

6-2. FRONT PANEL SECTION

Δ B : PANEL board
 Δ C : POWER SW board
 Δ D : REC VOL board
 Δ E : HP board
 Δ F : AC POWER SW board

Ref. No.	Part No.	Description	Remark
1	3-704-366-01	SCREW (CASE) (M3X8)	
* 2	3-931-432-01	CASE (410726)	
* 3	A-2007-523-A	MAIN BOARD, COMPLETE (KE200)	
* 3	A-2007-524-A	MAIN BOARD, COMPLETE (KE400S:EXCEPT US)	
* 3	A-2007-525-A	MAIN BOARD, COMPLETE (KE400S:US)	
* 3	A-2007-526-A	MAIN BOARD, COMPLETE (KE300:EXCEPT E)	
* 3	A-2007-527-A	MAIN BOARD, COMPLETE (KE300:E)	
* 3	A-2007-591-A	MAIN BOARD, COMPLETE (RX300)	
* 4	3-923-762-11	HOLDER (TR)	
* 5	A-2007-481-A	DOLBY-S BOARD, COMPLETE (KE400S)	
* 6	3-703-244-00	BUSHING (2104), CORD (EXCEPT US,E,CND)	
6	3-703-571-11	BUSHING (S) (4516), CORD (US,E,CND)	
* 7	3-933-281-01	PANEL, BACK (KE400S:US)	
* 7	3-933-281-11	PANEL, BACK (KE400S:AEP,G)	
* 7	3-933-281-21	PANEL, BACK (KE400S:UK)	
* 7	3-933-281-31	PANEL, BACK (KE400S:AUS)	
* 7	3-933-281-41	PANEL, BACK (KE300:AEP,G,MY,SP)	
* 7	3-933-281-51	PANEL, BACK (KE300:AUS)	
* 7	3-933-281-61	PANEL, BACK (KE300:E)	
* 7	3-933-281-81	PANEL, BACK (RX300)	

Ref. No.	Part No.	Description	Remark
* 7	3-933-307-01	PANEL, BACK (KE200:AEP,G)	
* 7	3-933-307-11	PANEL, BACK (KE200:UK)	
8	X-4947-207-1	FOOT ASSY (F50150S) (EXCEPT US,CND)	
8	X-4947-208-1	FOOT ASSY (F50150S) (US,CND)	
Δ 9	1-569-007-11	ADAPTER, CONVERSION 2P (E)	
10	4-956-370-12	BAND, PLUG FIXED (UK,AUS)	
* 11	3-346-265-31	HOLDER, PC BOARD	
Δ CNP901	1-558-945-21	CORD, POWER (POLAR.SPT-1) (US,CND)	
Δ CNP901	1-575-651-21	CORD, POWER (AEP,G,MY,SP)	
Δ CNP901	1-696-027-11	CORD, POWER (E)	
Δ CNP901	1-696-586-11	CORD, POWER (UK)	
Δ CNP901	1-696-845-11	CORD, POWER (AUS)	
Δ CNP901	1-751-523-11	CORD, POWER (UK)	
Δ S701	1-570-046-21	SWITCH, VOLTAGE CHANGE (E)	
Δ T901	1-426-651-11	TRANSFORMER, POWER (KE200,KE300:EXCEPT E)	
Δ T901	1-426-652-11	TRANSFORMER, POWER (KE300:E)	
Δ T901	1-427-743-11	TRANSFORMER, POWER (RX300)	
Δ T901	1-427-751-11	TRANSFORMER, POWER (KE400S:EXCEPT US)	
Δ T901	1-427-752-11	TRANSFORMER, POWER (KE400S:US)	

Ref. No.	Part No.	Description
51	X-3371-687-2	P
51	X-3371-688-2	P
51	X-3371-690-2	P
51	X-3371-694-2	P
51	X-3371-696-2	P
52	3-933-300-11	K
53	3-933-299-01	K
54	X-3371-691-2	L
54	X-3371-692-2	L
54	X-3371-693-2	L
55	3-931-429-01	B
56	1-773-287-11	W
* 57	3-377-337-11	H
58	4-951-620-01	S
59	A-4325-164-A	H
59	X-3368-119-1	H
60	3-354-963-01	D

6-2. FRONT PANEL SECTION

- ▲ B : PANEL board
- ▲ C : POWER SW board (US, CND, E)
- ▲ D : REC VOL board
- ▲ E : HP board
- ▲ F : AC POWER SW board (EXCEPT US, CND, E)

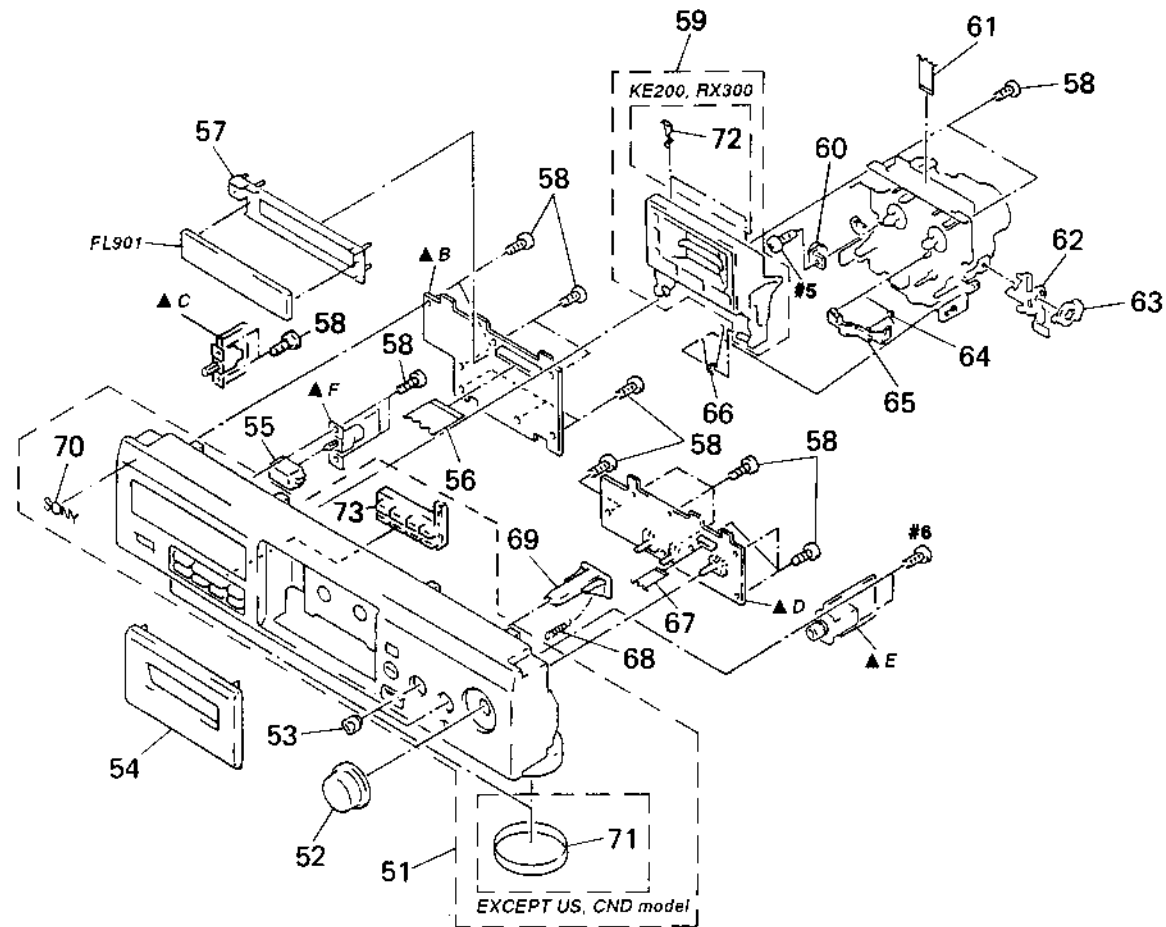

Ref. No.	Part No.	Description	Remark
51	X-3371-687-2	PANEL ASSY, FRONT (KE400S:EXCEPT US)	
51	X-3371-688-2	PANEL ASSY, FRONT (KE300)	
51	X-3371-690-2	PANEL ASSY, FRONT (KE200)	
51	X-3371-694-2	PANEL ASSY, FRONT (KE400S:US)	
51	X-3371-696-2	PANEL ASSY, FRONT (RX300)	
52	3-933-300-11	KNOB (REC)	
53	3-933-299-01	KNOB (DIA. 12)	
54	X-3371-691-2	LID ASSY, CASSETTE (KE400S,KE300)	
54	X-3371-692-2	LID ASSY, CASSETTE (RX300)	
54	X-3371-693-2	LID ASSY, CASSETTE (KE200)	
55	3-931-429-01	BUTTON (POWER)	
56	1-773-287-11	WIRE (FLAT TYPE) (29 CORE)	
* 57	3-377-337-11	HOLDER (FL)	
58	4-951-620-01	SCREW (2.6X8), +BVT	
59	A-4325-164-A	HOLDER (R) ASSY, CASSETTE (KE200,RX300)	
59	X-3368-119-1	HOLDER (R) ASSY, CASSETTE (KE300,KE400S)	
60	3-354-963-01	DAMPER	

Ref. No.	Part No.	Description	Remark
61	1-765-318-11	WIRE (FLAT TYPE) (7 CORE)	
* 62	3-354-954-01	LEVER (LOCK LEVER R)	
63	3-354-957-01	JOINT (LOCK LEVER)	
64	3-354-962-01	SPRING (EJ SAFTY SPRING R)	
65	3-354-956-01	LEVER (EJ SAFTY LEVER R)	
66	3-354-960-01	SPRING (LOADING R), TORSION	
67	1-769-947-11	WIRE (FLAT TYPE) (11 CORE)	
68	3-937-169-01	SPRING, TENSION	
69	3-933-295-01	BUTTON (EJECT)	
70	4-963-404-21	EMBLEM (5-A), SONY	
71	4-977-593-11	RING (DIA 50), ORNAMENTAL (EXCEPT US,CND)	
72	3-308-823-11	DETENT, CASSETTE (KE200,RX300)	
73	3-933-293-01	BUTTON (FWD) (EXCEPT RX300)	
73	3-933-294-01	BUTTON (REV) (RX300)	
FL901	1-517-173-11	INDICATOR TUBE, FLUORESCENT (KE200,KE300,RX300)	
FL901	1-517-374-11	INDICATOR TUBE, FLUORESCENT (KE400S)	

6-3. MECHANISM SECTION 1
 TC-KE200 : TCM-190VB22CS
 TC-KE300/KE400S : TCM-190VB12CS
 TC-RX300 : TCM-190RB12C

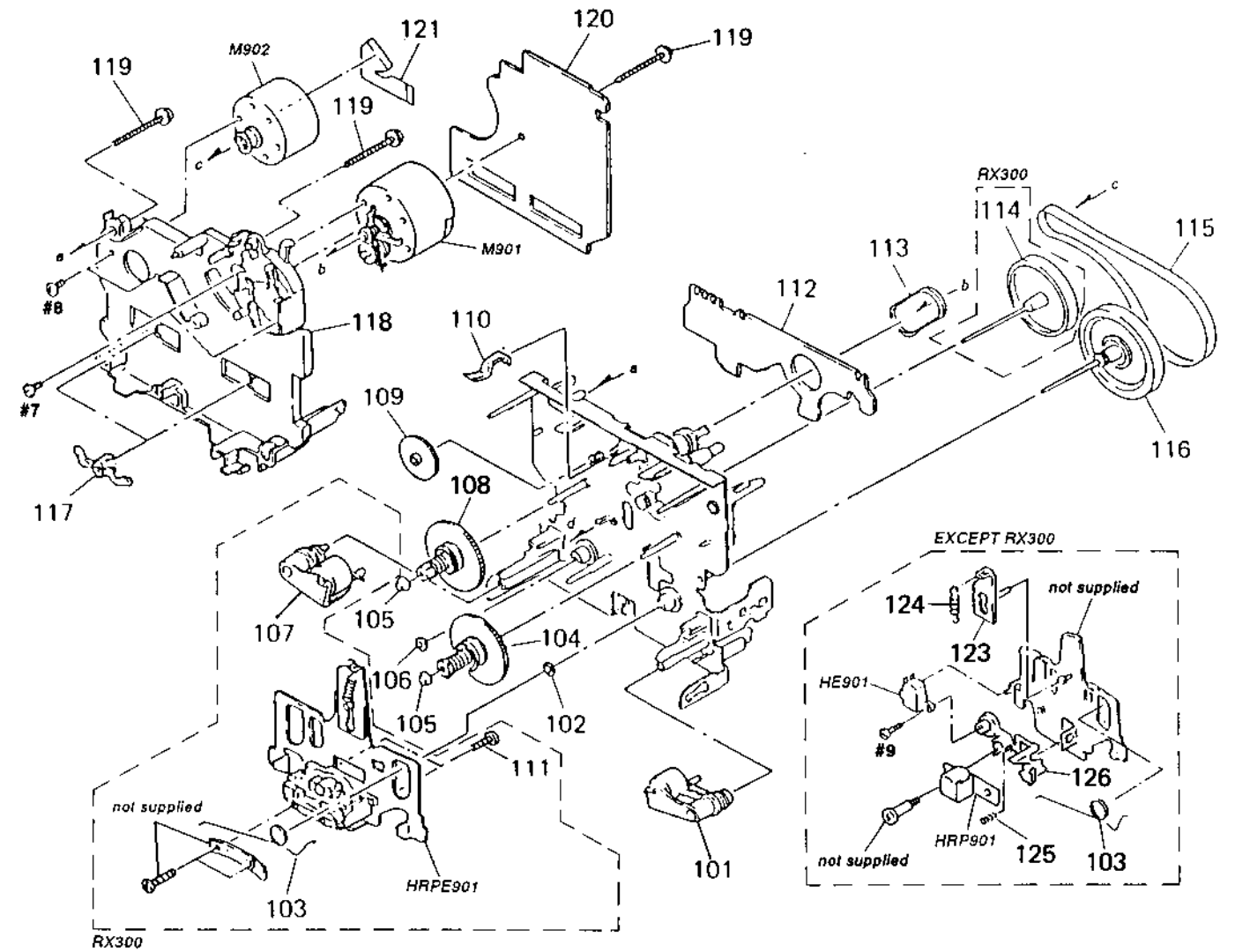

Ref. No.	Part No.	Description	Remark
101	X-3366-047-1	LEVER (PINCH F) ASSY	
102	3-356-713-01	WASHER	
103	3-907-362-01	SPRING, TORSION	
104	X-3366-970-1	TABLE ASSY, REEL	
105	3-362-308-01	CAP (REEL)	
106	3-356-714-01	WASHER (RX300)	
107	X-3366-048-1	LEVER (PINCH R) ASSY (RX300)	
108	X-3366-971-1	TABLE ASSY (B), REEL	
109	3-359-424-01	GEAR (REV GEAR)	
110	3-359-430-01	SPRING(CASSETTE RETAINER),LEAF	
111	3-388-848-01	SCREW (P2X6) (B TIGHT)(RX300)	
* 112	1-638-020-11	LEAF SW BOARD	
113	3-359-466-01	BELT (FR), SQUARE	
114	X-3367-630-1	FLYWHEEL (REV) ASSY (RX300)	
115	3-359-417-01	BELT (FLAT), CAPSTAN (RX300)	
115	3-359-467-01	BELT (1 WAY FLAT BELT) (EXCEPT RX300)	
116	X-3367-629-1	FLYWHEEL (1WD) ASSY	
117	3-575-321-00	RETAINER, THRUST, CAPSTAN	

Ref. No.	Part No.	Description	Remark
118	3-359-436-11	BASE (THRUST RETAINER),FITTING	
119	3-359-414-01	SCREW (+PTPWH 2X23)	
* 120	A-2006-890-A	AUDIO BOARD, COMPLETE (KE400S,KE300)	
* 120	A-2007-040-A	AUDIO BOARD, COMPLETE (RX300)	
* 120	A-2007-171-A	AUDIO BOARD, COMPLETE (KE200)	
121	1-638-983-11	MOTOR FLEXIBLE BOARD	
* 123	X-3368-865-1	SLIDER (LIMITER) ASSY (EXCEPT RX300)	
124	3-363-868-01	SPRING (HEAD CHASSIS), TENSION (EXCEPT RX300)	
125	3-343-484-01	SPRING, COMPRESSION (EXCEPT RX300)	
* 126	3-359-445-11	HOLDER (1 WAY HEAD)(EXCEPT RX300)	
HE901	1-543-673-11	HEAD, MAGNETIC (ERASE)(EXCEPT RX300)	
HRP901	1-543-919-11	HEAD,MAGNETIC(RECORD/PLAYBACK) (EXCEPT RX300)	
HRPE901A-2004-527-A		DECK ASSY, HEAD (RECORD/PLAYBACK/ERASE) (RX300)	
M901	X-3363-501-1	MOTOR ASSY,REEL (REEL)	
M902	X-3365-377-2	MOTOR ASSY,CAPSTAN (CAPSTAN)	

6-4. MECHANISM SECTION 2
 TC-KE200 : TCM-190VB22CS
 TC-KE300/KE400S : TCM-190VB12CS
 TC-RX300 : TCM-190RB12C

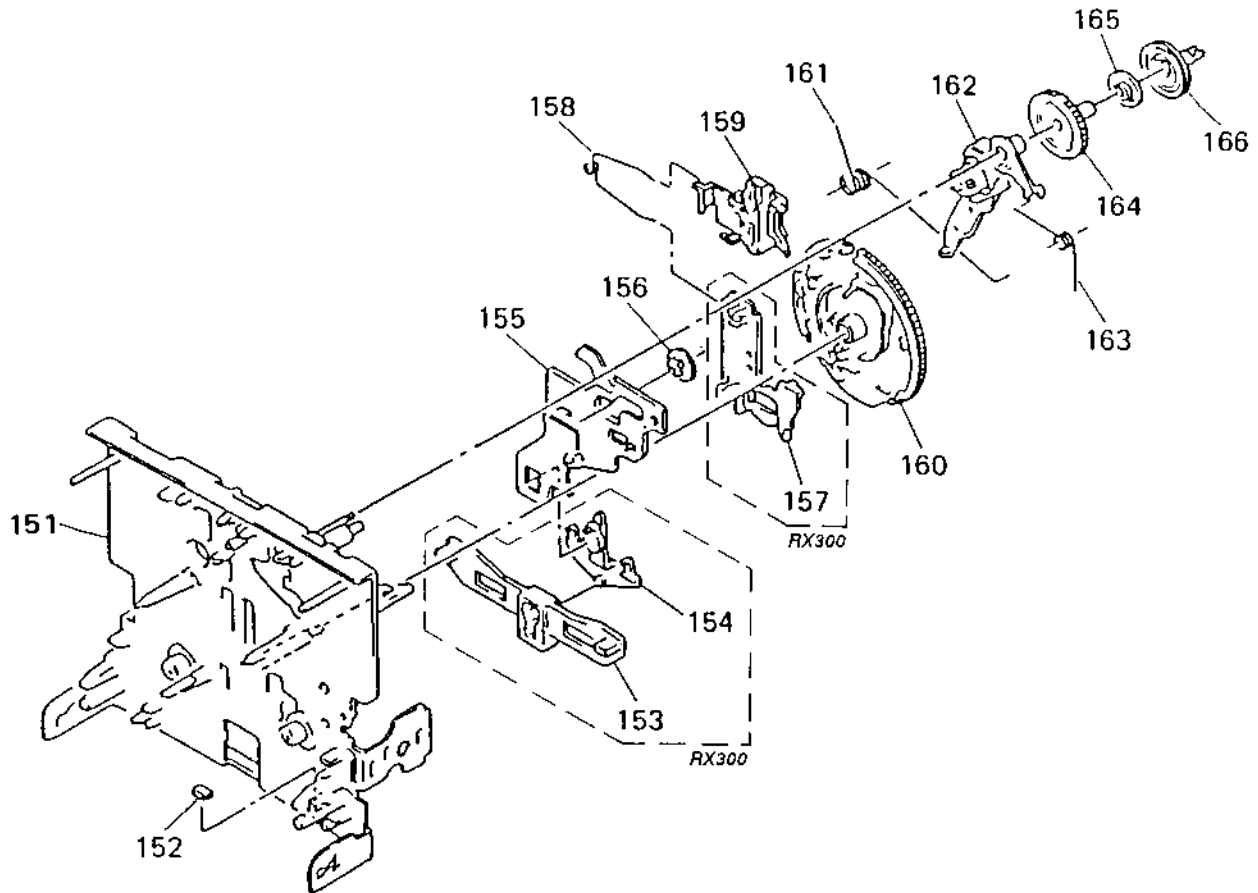

Ref. No.	Part No.	Description	Remark	Ref. No.	Part No.	Description	Remark
151	X-3359-415-1	CHASSIS ASSY, MECHANICAL		160	3-359-420-01	GEAR (CAM GEAR)(KE200)	
152	3-359-469-01	SPACER		160	3-936-483-01	GEAR (CAM GEAR)(EXCEPT KE200)	
153	3-359-425-01	SLIDER (REVERSE SLIDER)(RX300)		161	3-359-456-01	SPRING (TRIGGER SPRING), TORSION	
154	3-359-426-01	LEVER (REVERSE LEVER)(RX300)		162	X-3366-569-1	ARM ASSY, FR	
* 155	3-359-415-01	SLIDER (TRIGGER SLIDER)		163	3-924,187-11	S+RING (FR ARM), TORSION	
156	3-359-448-01	GEAR (TRIGGER)		164	3-359-419-11	GEAR (FR GEAR)	
157	3-359-427-01	SLIDER (LEVERSE SLIDER)(RX300)		165	3-359-421-01	CLUTCH (REEL DISK)	
158	3-359-454-01	SPRING, TORSION		166	3-359-418-01	PULLEY (FR PULLEY)	
159	3-359-429-01	SLIDER (BRAKE PLATE)					

AUDIO

SECTION 7 ELECTRICAL PARTS LIST

NOTE:

- Due to standardization, replacements in the parts list may be different from the parts specified in the diagrams or the components used on the set.
- -XX, -X mean standardized parts, so they may have some difference from the original one.
- RESISTORS
All resistors are in ohms
METAL : Metal-film resistor
METAL OXIDE : Metal oxide-film resistor
F : nonflammable
- Items marked " * " are not stocked since they are seldom required for routine service. Some delay should be anticipated when ordering these items.

● SEMICONDUCTORS

In each case, μ : μ , for example :
 μA : μA , μPA : μPA ...
 μPB : μPB , μPC : μPC ...
 μPD : μPD ...

● CAPACITORS

μF : μF

● COILS

μH : μH

● Abbreviation

CND : Canadian SP : Singapore
 AUS : Australian MY : Malaysia
 G : German

The components identified by mark Δ or dotted line with mark Δ are critical for safety.
 Replace only with part number specified.

Les composants identifiés par une marque Δ sont critiques pour la sécurité.
 Ne les remplacer que par une pièce portant le numéro spécifié.

When indicating parts by reference number, please include the board.

Ref. No.	Part No.	Description	Remark	Ref. No.	Part No.	Description	Remark
*	A-2006-890-A	AUDIO BOARD, COMPLETE (KE300,KE400S)		C51	1-164-161-11	CERAMIC CHIP 0.0022 μ F 10% 100V	
*	A-2007-040-A	AUDIO BOARD, COMPLETE (RX300)		C52	1-164-182-11	CERAMIC CHIP 0.0033 μ F 10% 50V	(RX300)
*	A-2007-171-A	AUDIO BOARD, COMPLETE (KE200)		C52	1-163-019-00	CERAMIC CHIP 0.0068 μ F 10% 50V	(KE300,KE400S)
		*****		C52	1-164-161-11	CERAMIC CHIP 0.0022 μ F 10% 100V	(KE200)
		< CAPACITOR >		C52	1-164-161-11	CERAMIC CHIP 0.0022 μ F 10% 100V	(RX300)
C11	1-163-133-00	CERAMIC CHIP 470PF 5% 50V	(KE200,KE300,KE400S)	C53	1-163-020-00	CERAMIC CHIP 0.0082 μ F 10% 50V	(KE300,KE400S)
C11	1-163-131-00	CERAMIC CHIP 390PF 5% 50V	(RX300)	C53	1-163-022-00	CERAMIC CHIP 0.012 μ F 10% 50V	(KE200)
C12	1-136-157-00	FILM 0.022 μ F 5% 50V		C53	1-163-019-00	CERAMIC CHIP 0.0068 μ F 10% 50V	(RX300)
C13	1-124-234-00	ELECT 22 μ F 20% 16V		C54	1-136-601-11	FILM 0.01 μ F 5% 630V	(EXCEPT KE200)
C14	1-136-272-00	FILM 68PF 5% 630V	(KE200)	C54	1-136-560-11	FILM 0.0056 μ F 5% 630V	(KE200)
C15	1-102-113-00	CERAMIC 390PF 10% 50V	(KE200)	C56	1-164-505-11	CERAMIC CHIP 2.2 μ F 16V	
C17	1-163-237-11	CERAMIC CHIP 27PF 5% 50V	(KE200)	C57	1-164-346-11	CERAMIC CHIP 1 μ F 16V	
C18	1-163-251-11	CERAMIC CHIP 100PF 5% 50V		C58	1-163-024-00	CERAMIC CHIP 0.018 μ F 10% 50V	(KE200)
C21	1-163-133-00	CERAMIC CHIP 470PF 5% 50V	(KE200,KE300,KE400S)	C71	1-164-346-11	CERAMIC CHIP 1 μ F 16V	(EXCEPT KE200)
C21	1-163-131-00	CERAMIC CHIP 390PF 5% 50V	(RX300)	C72	1-109-889-11	ELECT 1 μ F 20% 50V	(KE200)
C22	1-136-157-00	FILM 0.022 μ F 5% 50V		C80	1-124-234-00	ELECT 22 μ F 20% 16V	(EXCEPT KE200)
C23	1-124-234-00	ELECT 22 μ F 20% 16V		C81	1-164-232-11	CERAMIC CHIP 0.01 μ F 50V	(EXCEPT KE200)
C24	1-136-272-00	FILM 68PF 5% 630V	(KE200)	C82	1-136-157-00	FILM 0.022 μ F 5% 50V	(EXCEPT KE200)
C25	1-102-113-00	CERAMIC 390PF 10% 50V	(KE200)	C83	1-164-004-11	CERAMIC CHIP 0.1 μ F 10% 25V	(EXCEPT KE200)
C27	1-163-237-11	CERAMIC CHIP 27PF 5% 50V	(KE200)	C84	1-136-439-11	FILM 330PF 5% 630V	(KE300,KE400S)
C28	1-163-251-11	CERAMIC CHIP 100PF 5% 50V		C84	1-136-478-11	FILM 470PF 5% 630V	(RX300)
C31	1-124-234-00	ELECT 22 μ F 20% 16V		C85	1-136-433-11	FILM 100PF 5% 630V	(EXCEPT KE200)
C32	1-124-234-00	ELECT 22 μ F 20% 16V					
C33	1-124-234-00	ELECT 22 μ F 20% 16V					
C51	1-164-182-11	CERAMIC CHIP 0.0033 μ F 10% 50V	(KE300,KE400S)				
C51	1-163-019-00	CERAMIC CHIP 0.0068 μ F 10% 50V	(KE200)				

AUDIO

Ref. No.	Part No.	Description	Remark	Ref. No.	Part No.	Description	Remark
C86	1-163-143-00	CERAMIC CHIP	0.0012uF 5% 50V (EXCEPT KE200)	JW4	1-216-295-00	METAL CHIP	0 5% 1/10W (KE200)
C87	1-136-273-91	FILM	75PF 5% 630V (EXCEPT KE200)	JW6	1-216-295-00	METAL CHIP	0 5% 1/10W (KE200)
C88	1-163-003-11	CERAMIC CHIP	330PF 10% 50V (EXCEPT KE200)	JW7	1-216-295-00	METAL CHIP	0 5% 1/10W (KE200)
C89	1-124-234-00	ELECT	22uF 20% 16V (EXCEPT KE200)	JW52	1-216-296-00	METAL CHIP	0 5% 1/8W (KE200)
C90	1-107-584-11	CERAMIC	4PF 0.25PF 500V (EXCEPT KE200)	JW53	1-216-296-00	METAL CHIP	0 5% 1/8W (KE200)
C91	1-164-232-11	CERAMIC CHIP	0.01uF 50V (EXCEPT KE200)	JW54	1-216-296-00	METAL CHIP	0 5% 1/8W (KE200)
C92	1-136-157-00	FILM	0.022uF 5% 50V (EXCEPT KE200)	JW55	1-216-296-00	METAL CHIP	0 5% 1/8W (KE200)
C93	1-164-004-11	CERAMIC CHIP	0.1uF 10% 25V (EXCEPT KE200)	JW56	1-216-296-00	METAL CHIP	0 5% 1/8W (KE200)
C94	1-136-439-11	FILM	330PF 5% 630V (KE300,KE400S)	JW57	1-216-296-00	METAL CHIP	0 5% 1/8W (KE200)
C94	1-136-478-11	FILM	470PF 5% 630V (RX300)	JW58	1-216-296-00	METAL CHIP	0 5% 1/8W (KE200)
C95	1-136-433-11	FILM	100PF 5% 630V (EXCEPT KE200)	JW59	1-216-296-00	METAL CHIP	0 5% 1/8W (KE200)
C96	1-163-143-00	CERAMIC CHIP	0.0012uF 5% 50V (EXCEPT KE200)	JW60	1-216-296-00	METAL CHIP	0 5% 1/8W (KE200)
C97	1-136-273-91	FILM	75PF 5% 630V (EXCEPT KE200)	JW61	1-216-296-00	METAL CHIP	0 5% 1/8W (KE200)
C98	1-163-003-11	CERAMIC CHIP	330PF 10% 50V (EXCEPT KE200)	JW62	1-216-296-00	METAL CHIP	0 5% 1/8W (KE200)
C99	1-164-005-11	CERAMIC CHIP	0.47uF 25V (EXCEPT KE200)	JW63	1-216-296-00	METAL CHIP	0 5% 1/8W (KE200)
< CONNECTOR >				< COIL >			
* CNP31	1-580-782-11	CONNECTOR, BOARD TO BOARD		L11	1-410-780-11	INDUCTOR	27mH (KE200)
* CNP32	1-580-781-11	PIN, CONNECTOR (PC BOARD) 7P		L21	1-410-780-11	INDUCTOR	27mH (KE200)
* CNP33	1-580-782-11	CONNECTOR, BOARD TO BOARD		L81	1-410-780-11	INDUCTOR	27mH (EXCEPT KE200)
* CNP71	1-564-719-11	PIN, CONNECTOR (SMALL TYPE) 3P		L91	1-410-780-11	INDUCTOR	27mH (EXCEPT KE200)
CNP72	1-764-902-11	CONNECTOR, FFC/FPC 4P		< TRANSISTOR >			
* CNP75	1-564-718-11	PIN, CONNECTOR (SMALL TYPE) 2P (RX300)		Q51	8-729-822-05	TRANSISTOR	2SD1622-ST-TD (EXCEPT KE200)
< DIODE >				Q51	8-729-142-46	TRANSISTOR	2SC2001-LK (KE200)
D31	8-719-404-46	DIODE MA110		Q52	8-729-822-05	TRANSISTOR	2SD1622-ST-TD (EXCEPT KE200)
< IC >				Q52	8-729-142-46	TRANSISTOR	2SC2001-LK (KE200)
IC31	8-759-106-02	IC uPC4570-G2		Q53	8-729-822-05	TRANSISTOR	2SD1622-ST-TD (EXCEPT KE200)
IC81	8-759-106-56	IC uPC1297CA (EXCEPT KE200)		Q53	8-729-111-29	TRANSISTOR	2SD1616A-K (KE200)
< JUMPER RESISTOR >				Q71	8-729-602-36	TRANSISTOR	2SA1602-F (KE300,KE400S)
JW1	1-216-296-00	METAL CHIP	0 5% 1/8W (KE200)	Q71	8-729-216-22	TRANSISTOR	2SA1162-G (KE200,RX300)
JW2	1-216-295-00	METAL CHIP	0 5% 1/10W (KE200)	< RESISTOR >			
JW3	1-216-295-00	METAL CHIP	0 5% 1/10W (KE200)	R11	1-216-107-00	METAL CHIP	270K 5% 1/10W (EXCEPT RX300)
				R11	1-216-099-00	METAL CHIP	120K 5% 1/10W (RX300)
				R12	1-216-025-91	METAL GLAZE	100 5% 1/10W
				R13	1-216-100-00	METAL GLAZE	130K 5% 1/10W
				R14	1-216-068-00	METAL CHIP	6.2K 5% 1/10W

AUDIO

Ref. No.	Part No.	Description	Remark	Ref. No.	Part No.	Description	Remark
R15	1-249-430-11	CARBON	12K 5% 1/4W (KE200)	R85	1-216-075-00	METAL CHIP	12K 5% 1/10W (EXCEPT KE200)
R21	1-216-107-00	METAL CHIP	270K 5% 1/10W (EXCEPT RX300)	R91	1-216-073-00	METAL CHIP	10K 5% 1/10W (EXCEPT KE200)
R21	1-216-099-00	METAL CHIP	120K 5% 1/10W (RX300)	R92	1-216-085-00	METAL CHIP	33K 5% 1/10W (EXCEPT KE200)
R22	1-216-025-91	METAL GLAZE	100 5% 1/10W	R93	1-216-001-00	METAL CHIP	10 5% 1/10W (EXCEPT KE200)
R23	1-216-100-00	METAL GLAZE	130K 5% 1/10W	R94	1-216-101-00	METAL CHIP	150K 5% 1/10W (EXCEPT KE200)
R24	1-216-068-00	METAL CHIP	6.2K 5% 1/10W	R95	1-216-075-00	METAL CHIP	12K 5% 1/10W (EXCEPT KE200)
R25	1-249-430-11	CARBON	12K 5% 1/4W (KE200)	< VARIABLE RESISTOR >			
R31	1-216-033-00	METAL CHIP	220 5% 1/10W	RV11	1-241-761-11	RES. ADJ. CARBON 1K (PB LEVEL L)	
R32	1-216-033-00	METAL CHIP	220 5% 1/10W	RV12	1-238-551-11	RES. ADJ. CARBON 220K (BIAS L) (KE200)	
R33	1-216-065-00	METAL CHIP	4.7K 5% 1/10W (EXCEPT KE200)	RV21	1-241-761-11	RES. ADJ. CARBON 1K (PB LEVEL R) (KE200,RX300)	
R41	1-249-393-11	CARBON	10 5% 1/4W (KE200)	RV22	1-238-551-11	RES. ADJ. CARBON 220K (BIAS R) (KE200)	
R42	1-249-393-11	CARBON	10 5% 1/4W (KE200)	RV71	1-241-630-11	RES. ADJ. CARBON 10K (TAPE SPEED L) (KE200,RX300)	
R51	1-216-091-00	METAL CHIP	56K 5% 1/10W (KE300,KE400S)	RV71	1-241-761-11	RES. ADJ. CARBON 1K (TAPE SPEED L) (KE300,KE400S)	
R51	1-216-085-00	METAL CHIP	33K 5% 1/10W (KE200)	RV72	1-241-630-11	RES. ADJ. CARBON 10K (TAPE SPEED H) (KE200,RX300)	
R51	1-216-097-91	METAL GLAZE	100K 5% 1/10W (RX300)	RV72	1-241-762-11	RES. ADJ. CARBON 2.2K (TAPE SPEED H) (KE300,KE400S)	
R52	1-216-091-00	METAL CHIP	56K 5% 1/10W (KE300,KE400S)	RV81	1-241-786-11	RES. ADJ. CARBON 22K (REC BIAS L) (EXCEPT KE200)	
R52	1-216-085-00	METAL CHIP	33K 5% 1/10W (KE200)	RV91	1-241-786-11	RES. ADJ. CARBON 22K (REC BIAS R) (EXCEPT KE200)	
R52	1-216-097-91	METAL GLAZE	100K 5% 1/10W (RX300)	< RELAY >			
R53	1-216-073-00	METAL CHIP	10K 5% 1/10W	RY31	1-515-913-11	RELAY	
R54	1-216-309-00	METAL CHIP	5.6 5% 1/10W	< TRANSFORMER >			
R55	1-216-309-00	METAL CHIP	5.6 5% 1/10W	T51	1-433-383-11	TRANSFORMER, BIAS OSCILLATION (KE300,KE400S)	
R56	1-216-298-00	METAL CHIP	2.2 5% 1/10W (KE200)	T51	1-426-650-11	TRANSFORMER, BIAS OSCILLATION (KE200)	
R57	1-216-298-00	METAL CHIP	2.2 5% 1/10W (EXCEPT KE200)	T51	1-406-417-11	COIL, BIAS OSCILLATION (RX300)	
R71	1-216-025-91	METAL GLAZE	100 5% 1/10W (KE300,KE400S)	T81	1-433-398-11	TRANSFORMER, BIAS OSCILLATOR (KE300,KE400S)	
R71	1-216-082-00	METAL GLAZE	24K 5% 1/10W (KE200,RX300)	T81	1-433-381-11	TRANSFORMER, BIAS OSCILLATOR (RX300)	
R72	1-216-055-00	METAL CHIP	1.8K 5% 1/10W (KE300,KE400S)	T91	1-433-398-11	TRANSFORMER, BIAS OSCILLATOR (KE300,KE400S)	
R72	1-216-081-00	METAL CHIP	22K 5% 1/10W (KE200,RX300)	T91	1-433-381-11	TRANSFORMER, BIAS OSCILLATOR (RX300)	
R73	1-216-089-91	METAL GLAZE	47K 5% 1/10W	< TEST PIN >			
R74	1-216-089-91	METAL GLAZE	47K 5% 1/10W	TP81	1-568-449-11	HOUSING, CONNECTOR(PC BOARD)3P (EXCEPT KE200)	
R81	1-216-073-00	METAL CHIP	10K 5% 1/10W (EXCEPT KE200)	*****			
R82	1-216-085-00	METAL CHIP	33K 5% 1/10W (EXCEPT KE200)				
R83	1-216-001-00	METAL CHIP	10 5% 1/10W (EXCEPT KE200)				
R84	1-216-101-00	METAL CHIP	150K 5% 1/10W (EXCEPT KE200)				

DOLBY-S (KE400S)

LEAF SW

Ref. No.	Part No.	Description	Remark		
*	A-2007-481-A	DOLBY-S BOARD, COMPLETE (KE400S) *****			
< CAPACITOR >					
C1	1-136-165-00	FILM	0.1uF	5%	50V
C2	1-163-012-00	CERAMIC CHIP	0.0018uF	10%	50V
C3	1-163-012-00	CERAMIC CHIP	0.0018uF	10%	50V
C4	1-164-222-11	CERAMIC CHIP	0.22uF		25V
C5	1-136-165-00	FILM	0.1uF	5%	50V
C6	1-136-165-00	FILM	0.1uF	5%	50V
C7	1-137-372-11	FILM	0.022uF	5%	50V
C8	1-164-222-11	CERAMIC CHIP	0.22uF		25V
C9	1-126-301-11	ELECT	1uF	20%	50V
C10	1-137-442-11	FILM	0.039uF	5%	50V
C11	1-163-007-11	CERAMIC CHIP	680PF	10%	50V
C12	1-164-717-11	CERAMIC CHIP	0.0082uF	5%	50V
C13	1-163-038-91	CERAMIC CHIP	0.1uF		25V
C14	1-124-465-00	ELECT	0.47uF	20%	50V
C15	1-164-222-11	CERAMIC CHIP	0.22uF		25V
C16	1-163-038-91	CERAMIC CHIP	0.1uF		25V
C17	1-124-465-00	ELECT	0.47uF	20%	50V
C18	1-163-038-91	CERAMIC CHIP	0.1uF		25V
C19	1-164-222-11	CERAMIC CHIP	0.22uF		25V
C20	1-163-035-00	CERAMIC CHIP	0.047uF		50V
C21	1-164-717-11	CERAMIC CHIP	0.0082uF	5%	50V
C22	1-164-161-11	CERAMIC CHIP	0.0022uF	10%	100V
C23	1-163-005-11	CERAMIC CHIP	470PF	10%	50V
C24	1-137-442-11	FILM	0.039uF	5%	50V
C25	1-136-165-00	FILM	0.1uF	5%	50V
C26	1-137-372-11	FILM	0.022uF	5%	50V
C28	1-163-038-91	CERAMIC CHIP	0.1uF		25V
< CONNECTOR >					
CN1	1-695-092-11	SOCKET, CONNECTOR 7P			
< IC >					
IC1	8-752-076-30	IC CXA1917AM			
< JUMPER RESISTOR >					
J1	1-216-296-00	METAL CHIP	0	0.5%	1/8W
J2	1-216-296-00	METAL CHIP	0	0.5%	1/8W
J3	1-216-296-00	METAL CHIP	0	0.5%	1/8W
< RESISTOR >					
R1	1-216-685-11	METAL CHIP	27K	0.5%	1/10W
R2	1-208-811-11	METAL GLAZE	16K	2%	1/10W
R3	1-208-791-11	METAL GLAZE	2.4K	2%	1/10W
R4	1-208-799-11	METAL GLAZE	5.1K	2%	1/10W
R5	1-216-689-11	METAL CHIP	39K	0.5%	1/10W
R6	1-216-689-11	METAL CHIP	39K	0.5%	1/10W
R7	1-216-615-11	METAL CHIP	33	0.5%	1/10W

Ref. No.	Part No.	Description	Remark		
R8	1-208-462-41	METAL GLAZE	10K	2%	1/10W
R9	1-208-812-11	METAL GLAZE	18K	2%	1/10W
R10	1-216-615-11	METAL CHIP	33	0.5%	1/10W
R11	1-216-619-11	METAL CHIP	47	0.5%	1/10W
R12	1-216-684-11	METAL CHIP	24K	0.5%	1/10W
R13	1-216-615-11	METAL CHIP	33	0.5%	1/10W
R14	1-216-619-11	METAL CHIP	47	0.5%	1/10W
R15	1-216-655-11	METAL CHIP	1.5K	0.5%	1/10W
R16	1-216-678-11	METAL CHIP	13K	0.5%	1/10W
R17	1-216-673-11	METAL CHIP	8.2K	0.5%	1/10W
R18	1-208-462-41	METAL GLAZE	10K	2%	1/10W
R19	1-208-462-41	METAL GLAZE	10K	2%	1/10W
R20	1-216-689-11	METAL CHIP	39K	0.5%	1/10W

*	1-638-020-11	LEAF SW BOARD *****			
< CONNECTOR >					
* CNP81	1-568-850-11	SOCKET, CONNECTOR 7P			
CNP81	1-695-368-31	PIN, CONNECTOR (PC BOARD) 7P			
< IC >					
IC81	8-749-924-10	IC (PHONT REFLECTOR NJL5165K-B (H1))			
< RESISTOR >					
R81	1-249-414-11	CARBON	560	5%	1/4W
R82	1-247-818-11	CARBON	300	5%	1/4W (RX300)
R83	1-247-834-11	CARBON	1.3K	5%	1/4W
R84	1-249-417-11	CARBON	1K	5%	1/4W
R85	1-249-408-11	CARBON	180	5%	1/4W
< SWITCH >					
S81	1-571-958-11	SWITCH, PUSH (1 KEY) (STOP)			
S82	1-571-281-21	SWITCH, LEAF (70uS)			
S83	1-571-281-21	SWITCH, LEAF (METAL)			
S84	1-571-281-21	SWITCH, LEAF (REC-A)			
S85	1-571-281-21	SWITCH, LEAF (REC-B) (RX300)			
S86	1-571-281-21	SWITCH, LEAF (HALF)			

MAIN

AC POWER SW

PANEL

POWER SW

REC VOL

TRANSFORMER

HP

Ref. No.	Part No.	Description	Remark	Ref. No.	Part No.	Description	Remark
*	A-2007-523-A	MAIN BOARD, COMPLETE (KE200)		C207	1-126-965-11	ELECT	22uF 20% 50V
*	A-2007-524-A	MAIN BOARD, COMPLETE (KE400S:EXCEPT US)		C208	1-126-964-11	ELECT	10uF 20% 50V
*	A-2007-525-A	MAIN BOARD, COMPLETE (KE400S:US)		C209	1-126-964-11	ELECT	10uF 20% 50V
*	A-2007-526-A	MAIN BOARD, COMPLETE (KE300:EXCEPT E)		C210	1-126-963-11	ELECT	4.7uF 20% 50V
*	A-2007-527-A	MAIN BOARD, COMPLETE (KE300:E)		C211	1-126-962-11	ELECT	3.3uF 20% 50V
*	A-2007-591-A	MAIN BOARD, COMPLETE (RX300)		C212	1-124-902-00	ELECT	0.47uF 20% 50V
		*****		C213	1-126-963-11	ELECT	4.7uF 20% 50V
		AC POWER SW BOARD (EXCEPT US,CND,E)		C231	1-126-963-11	ELECT	4.7uF 20% 50V
		*****					(EXCEPT KE200)
		PANEL BOARD		C232	1-126-962-11	ELECT	3.3uF 20% 50V
		*****		C233	1-162-294-31	CERAMIC	0.001uF 10% 50V
		POWER SW BOARD (US,CND,E)		C501	1-126-952-11	ELECT	1000uF 20% 16V
		*****		C502	1-126-964-11	ELECT	10uF 20% 50V
		REC VOL BOARD		C503	1-126-964-11	ELECT	10uF 20% 50V
		*****		C504	1-124-903-11	ELECT	1uF 20% 50V
		TRANSFORMER BOARD					(EXCEPT KE200)
		*****		C505	1-126-964-11	ELECT	10uF 20% 50V
		HP BOARD		C506	1-126-925-11	ELECT	470uF 20% 10V
		*****					(KE400S,KE200)
*	3-377-337-11	HOLDER (FL)		C506	1-126-933-11	ELECT	100uF 20% 10V
*	3-923-762-11	HOLDER (TR)					(KE300,RX300)
		< CAPACITOR >		C511	1-137-374-11	FILM	0.047uF 5% 50V
C101	1-137-372-11	FILM	0.022uF 5% 50V				(EXCEPT KE200)
C101	1-136-157-00	FILM	0.022uF 5% 50V	C512	1-136-164-00	FILM	0.082uF 5% 50V
			(KE200)				(EXCEPT KE200)
C102	1-126-963-11	ELECT	4.7uF 20% 50V	C513	1-137-367-11	FILM	0.0033uF 5% 50V
C103	1-162-302-11	CERAMIC	0.0022uF 20% 16V				(EXCEPT KE200)
			(EXCEPT KE200)	C521	1-126-964-11	ELECT	10uF 20% 50V
C104	1-126-964-11	ELECT	10uF 20% 50V	C551	1-162-282-31	CERAMIC	100PF 10% 50V
C105	1-136-165-00	FILM	0.1uF 5% 50V	C552	1-161-494-00	CERAMIC	0.022uF 25V
C106	1-136-163-00	FILM	0.068uF 5% 50V	C553	1-162-217-31	CERAMIC	56PF 5% 50V
C107	1-126-965-11	ELECT	22uF 20% 50V	C554	1-124-925-11	ELECT	2.2uF 20% 100V
C108	1-126-964-11	ELECT	10uF 20% 50V	C555	1-124-925-11	ELECT	2.2uF 20% 100V
			(KE400S)	C571	1-124-925-11	ELECT	2.2uF 20% 100V
C109	1-126-964-11	ELECT	10uF 20% 50V	C572	1-126-916-11	ELECT	1000uF 20% 6.3V
C110	1-126-963-11	ELECT	4.7uF 20% 50V	C601	1-164-159-11	CERAMIC	0.1uF 50V
C111	1-126-962-11	ELECT	3.3uF 20% 50V	C602	1-162-288-31	CERAMIC	330PF 10% 50V
C112	1-124-902-00	ELECT	0.47uF 20% 50V	C701	1-126-943-11	ELECT	2200uF 20% 25V
C113	1-126-963-11	ELECT	4.7uF 20% 50V	C702	1-126-943-11	ELECT	2200uF 20% 25V
C131	1-126-963-11	ELECT	4.7uF 20% 50V	C703	1-104-664-11	ELECT	47uF 20% 25V
			(EXCEPT KE200)	C704	1-126-926-11	ELECT	1000uF 20% 10V
C132	1-126-962-11	ELECT	3.3uF 20% 50V	C705	1-126-926-11	ELECT	1000uF 20% 10V
C133	1-162-294-31	CERAMIC	0.001uF 10% 50V	C706	1-126-935-11	ELECT	470uF 20% 6.3V
C201	1-137-372-11	FILM	0.022uF 5% 50V				
			(EXCEPT KE200)	C707	1-126-964-11	ELECT	10uF 20% 50V
C201	1-136-157-00	FILM	0.022uF 5% 50V	C708	1-126-963-11	ELECT	4.7uF 20% 50V
			(KE200)	C709	1-126-968-11	ELECT	100uF 20% 50V
C202	1-126-963-11	ELECT	4.7uF 20% 50V	C710	1-104-664-11	ELECT	47uF 20% 25V
C203	1-162-302-11	CERAMIC	0.0022uF 20% 16V	C711	1-164-159-11	CERAMIC	0.1uF 50V
			(EXCEPT KE200)	C712	1-161-494-00	CERAMIC	0.022uF 25V
C204	1-126-964-11	ELECT	10uF 20% 50V	△C713	1-113-925-11	CERAMIC	0.01uF 20% 250V
C205	1-136-165-00	FILM	0.1uF 5% 50V				(EXC EPT US,E)
C206	1-136-163-00	FILM	0.068uF 5% 50V				

<p>The components identified by mark Δ or dotted line with mark Δ are critical for safety. Replace only with part number specified.</p>	<p>Les composants identifiés par une marque Δ sont critiques pour la sécurité. Ne les remplacer que par une pièce portant le numéro spécifié.</p>
---	---

MAIN

AC POWER SW

PANEL

POWER SW

REC VOL

TRANSFORMER

HP

Ref. No.	Part No.	Description	Remark	Ref. No.	Part No.	Description	Remark
C714	1-136-169-00	FILM	0.22uF 5% 50V (KE200,KE300:EXCEPT E.KE400S)	D709	8-719-933-54	DIODE HZS9A2L	
C715	1-136-169-00	FILM	0.22uF 5% 50V (KE200,KE300:EXCEPT E.KE400S)	D710	8-719-000-60	DIODE UZL-6M2	
△C716	1-113-920-11	CERAMIC	0.0022uF 20% 250V (RX300)	D711	8-719-987-63	DIODE 1N4148M	
C801	1-126-963-11	ELECT	4.7uF 20% 50V	D712	8-719-987-63	DIODE 1N4148M	
C803	1-161-494-00	CERAMIC	0.022uF 25V	D713	8-719-000-93	DIODE UZL-7H1	
C804	1-161-494-00	CERAMIC	0.022uF 25V	D714	8-719-987-63	DIODE 1N4148M	
C805	1-161-494-00	CERAMIC	0.022uF 25V	D715	8-719-985-41	DIODE HZS2CLL	
C806	1-126-964-11	ELECT	10uF 20% 50V	D801	8-719-933-33	DIODE HZS6A1L	
C807	1-126-935-11	ELECT	470uF 20% 6.3V	D802	8-719-933-33	DIODE HZS6A1L	
C808	1-161-494-00	CERAMIC	0.022uF 25V	< INDICATOR TUBE >			
C809	1-161-494-00	CERAMIC	0.022uF 25V	FL901	1-517-374-11	INDICATOR TUBE, FLUORESCENT (KE400S)	
C810	1-162-282-31	CERAMIC	100PF 10% 50V	FL901	1-517-173-11	INDICATOR TUBE, FLUORESCENT (EXCEPT KE400S)	
C811	1-164-159-11	CERAMIC	0.1uF 50V	< IC >			
C812	1-137-374-11	FILM	0.047uF 5% 50V (KE200,KE300:EXCEPT E.KE400S)	IC501	8-752-066-35	IC CXA1563S (KE400S)	
< CONNECTOR >				IC501	8-752-060-46	IC CXA1561S (EXCEPT KE400S)	
* CN81	1-568-826-11	SOCKET, CONNECTOR 7P		IC502	8-752-055-62	IC CXA1579P (EXCEPT RX300)	
CN101	1-695-087-11	PIN, CONNECTOR (PC BOARD) 7P (KE400S)		IC502	8-752-055-61	IC CXA1578P (RX300)	
CN201	1-695-087-11	PIN, CONNECTOR (PC BOARD) 7P (KE400S)		IC503	8-759-634-51	IC M5218AP (EXCEPT KE200)	
* CN504	1-568-830-11	SOCKET, CONNECTOR 11P		IC504	8-759-634-51	IC M5218AP	
* CN505	1-568-954-11	PIN, CONNECTOR 5P (US,CND,E)		IC505	8-759-634-51	IC M5218AP	
CN506	1-506-468-11	PIN, CONNECTOR 3P		IC506	8-759-140-53	IC MC14053BCP (EXCEPT KE200)	
CN701	1-564-510-11	PLUG, CONNECTOR 7P		IC507	8-759-634-51	IC M5218AP (EXCEPT KE200)	
* CN702	1-580-230-31	PIN, CONNECTOR (PC BOARD) 2P		IC508	8-759-000-48	IC MC14052BCP	
* CN703	1-573-565-11	PIN, CONNECTOR 5P (KE300:E)		IC509	8-759-916-14	IC SN74HC04AN (EXCEPT KE200)	
CN704	1-568-226-11	PIN, CONNECTOR 2P (EXCEPT US,E)		IC510	8-759-634-51	IC M5218AP	
* CN801	1-568-844-11	SOCKET, CONNECTOR 29P		IC511	8-759-634-51	IC M5218AP	
* CN901	1-568-844-11	SOCKET, CONNECTOR 29P		IC512	8-759-634-51	IC M5218AP (KE400S)	
* CN904	1-568-830-11	SOCKET, CONNECTOR 11P		IC601	8-759-803-42	IC LA6500-FA	
* CNB31	1-691-916-11	CONNECTOR, BOARD TO BOARD		IC701	8-759-634-51	IC M5218AP	
* CNB33	1-691-916-11	CONNECTOR, BOARD TO BOARD		IC801	8-752-856-27	IC CXP82612-022Q	
< DIODE >				IC802	8-759-165-82	IC PST600E-T	
D131	8-719-987-63	DIODE 1N4148M		IC901	8-741-810-59	IC SBX1810-59	
D132	8-719-987-63	DIODE 1N4148M		< JACK >			
D231	8-719-987-63	DIODE 1N4148M		J501	1-770-614-11	JACK, PIN 4P (LINE)	
D232	8-719-987-63	DIODE 1N4148M		J502	1-568-519-41	JACK, LARGE TYPE (PHONES)	
D511	8-719-987-63	DIODE 1N4148M (EXCEPT KE200)		< FILTER >			
D512	8-719-987-63	DIODE 1N4148M (EXCEPT KE200)		LPF101	1-235-175-11	FILTER, LOW PASS (EXCEPT KE200)	
D513	8-719-987-63	DIODE 1N4148M		LPF101	1-236-087-11	FILTER, LOW PASS (KE200)	
D551	8-719-987-63	DIODE 1N4148M		LPF201	1-235-175-11	FILTER, LOW PASS (EXCEPT KE200)	
D701	8-719-024-99	DIODE 11ES2-NTA2B		LPF201	1-236-087-11	FILTER, LOW PASS (KE200)	
D702	8-719-024-99	DIODE 11ES2-NTA2B		< TRANSISTOR >			
D703	8-719-024-99	DIODE 11ES2-NTA2B		Q101	8-729-900-89	TRANSISTOR DTC144ES	
D704	8-719-024-99	DIODE 11ES2-NTA2B		Q102	8-729-900-80	TRANSISTOR DTC114ES (EXCEPT KE200)	
D705	8-719-024-99	DIODE 11ES2-NTA2B		Q121	8-729-922-37	TRANSISTOR 2SD2144S-UVW	
D706	8-719-024-99	DIODE 11ES2-NTA2B		Q122	8-729-119-78	TRANSISTOR 2SC2785-HFE (EXCEPT KE200)	
D707	8-719-024-99	DIODE 11ES2-NTA2B		Q201	8-729-900-89	TRANSISTOR DTC144ES	
D708	8-719-933-33	DIODE HZS6A1L					

The components identified by mark △ or dotted line with mark △ are critical for safety. Replace only with part number specified.

Les composants identifiés par une marque △ sont critiques pour la sécurité. Ne les remplacer que par une pièce portant le numéro spécifié.

MAIN

AC POWER SW

PANEL

POWER SW

REC VOL

TRANSFORMER

HP

Ref. No.	Part No.	Description	Remark
Q202	8-729-900-80	TRANSISTOR DTC114ES (EXCEPT KE200)	
Q221	8-729-922-37	TRANSISTOR 2SD2144S-UVW	
Q222	8-729-119-78	TRANSISTOR 2SC2785-HFE (EXCEPT KE200)	
Q503	8-729-422-57	TRANSISTOR UN4111	
Q504	8-729-900-80	TRANSISTOR DTC114ES	
Q505	8-729-900-89	TRANSISTOR DTC144ES (RX300)	
Q511	8-729-119-78	TRANSISTOR 2SC2785-HFE (EXCEPT KE200)	
Q512	8-729-900-74	TRANSISTOR DTC143ES (EXCEPT KE200)	
Q521	8-729-900-80	TRANSISTOR DTC114ES	
Q531	8-729-422-57	TRANSISTOR UN4111 (EXCEPT KE200)	
Q532	8-729-900-80	TRANSISTOR DTC114ES	
Q551	8-729-119-76	TRANSISTOR 2SA1175-HFE	
Q572	8-729-422-57	TRANSISTOR UN4111	
Q573	8-729-900-65	TRANSISTOR DTA144ES (EXCEPT KE200)	
Q601	8-729-801-93	TRANSISTOR 2SD1387-3	
Q701	8-729-141-83	TRANSISTOR 2SB1094-LK	
Q702	8-729-209-15	TRANSISTOR 2SD2012	
Q703	8-729-900-74	TRANSISTOR DTC143TS (EXCEPT KE200)	
Q704	8-729-141-83	TRANSISTOR 2SB1094-LK	
Q705	8-729-119-78	TRANSISTOR 2SC2785-HFE	
Q706	8-729-900-74	TRANSISTOR DTC143TS (EXCEPT KE200)	
Q707	8-729-119-76	TRANSISTOR 2SA1175-HFE	
Q708	8-729-140-04	TRANSISTOR 2SB1116A-L	
Q803	8-729-900-80	TRANSISTOR DTC114ES	
Q805	8-729-119-76	TRANSISTOR 2SA1175-HFE	
< RESISTOR >			
R101	1-247-838-00	CARBON 2K	5% 1/4W (EXCEPT RX300)
R101	1-249-421-11	CARBON 2.2K	5% 1/4W (RX300)
R102	1-247-842-11	CARBON 3K	5% 1/4W (EXCEPT RX300)
R102	1-249-423-11	CARBON 3.3K	5% 1/4W (RX300)
R104	1-249-417-11	CARBON 1K	5% 1/4W
R105	1-249-423-11	CARBON 3.3K	5% 1/4W
R106	1-247-887-00	CARBON 220K	5% 1/4W (EXCEPT KE200)
R107	1-249-428-11	CARBON 8.2K	5% 1/4W
R108	1-249-429-11	CARBON 10K	5% 1/4W
R110	1-249-429-11	CARBON 10K	5% 1/4W
R111	1-249-423-11	CARBON 3.3K	5% 1/4W
R112	1-247-864-11	CARBON 24K	5% 1/4W (KE400S)
R113	1-249-429-11	CARBON 10K	5% 1/4W (KE400S)
R114	1-249-437-11	CARBON 47K	5% 1/4W (KE400S)
R121	1-249-437-11	CARBON 47K	5% 1/4W
R122	1-249-421-11	CARBON 2.2K	5% 1/4W
R123	1-249-421-11	CARBON 2.2K	5% 1/4W

Ref. No.	Part No.	Description	Remark
R124	1-249-437-11	CARBON 47K	5% 1/4W (EXCEPT KE200)
R125	1-249-425-11	CARBON 4.7K	5% 1/4W (EXCEPT KE200)
R131	1-249-425-11	CARBON 4.7K	5% 1/4W (EXCEPT KE200)
R132	1-247-822-11	CARBON 430	5% 1/4W (EXCEPT KE200)
R133	1-247-866-11	CARBON 30K	5% 1/4W (EXCEPT KE200)
R134	1-249-435-11	CARBON 33K	5% 1/4W
R135	1-249-439-11	CARBON 68K	5% 1/4W
R136	1-249-410-11	CARBON 270	5% 1/4W
R141	1-249-432-11	CARBON 18K	5% 1/4W
R142	1-249-432-11	CARBON 18K	5% 1/4W
R143	1-249-423-11	CARBON 3.3K	5% 1/4W
R144	1-247-848-11	CARBON 5.1K	5% 1/4W
R145	1-249-409-11	CARBON 220	5% 1/4W
R151	1-249-433-11	CARBON 22K	5% 1/4W
R152	1-249-417-11	CARBON 1K	5% 1/4W
R153	1-249-441-11	CARBON 100K	5% 1/4W
R154	1-249-433-11	CARBON 22K	5% 1/4W
R201	1-247-838-00	CARBON 2K	5% 1/4W (EXCEPT RX300)
R201	1-249-421-11	CARBON 2.2K	5% 1/4W (RX300)
R202	1-247-842-11	CARBON 3K	5% 1/4W (EXCEPT RX300)
R202	1-249-423-11	CARBON 3.3K	5% 1/4W (RX300)
R204	1-249-417-11	CARBON 1K	5% 1/4W
R205	1-249-423-11	CARBON 3.3K	5% 1/4W
R206	1-247-887-00	CARBON 220K	5% 1/4W (EXCEPT KE200)
R207	1-249-428-11	CARBON 8.2K	5% 1/4W
R208	1-249-429-11	CARBON 10K	5% 1/4W
R210	1-249-429-11	CARBON 10K	5% 1/4W
R211	1-249-423-11	CARBON 3.3K	5% 1/4W
R212	1-247-864-11	CARBON 24K	5% 1/4W (KE400S)
R213	1-249-429-11	CARBON 10K	5% 1/4W (KE400S)
R214	1-249-437-11	CARBON 47K	5% 1/4W (KE400S)
R221	1-249-437-11	CARBON 47K	5% 1/4W
R222	1-249-421-11	CARBON 2.2K	5% 1/4W
R223	1-249-421-11	CARBON 2.2K	5% 1/4W
R224	1-249-437-11	CARBON 47K	5% 1/4W (EXCEPT KE200)
R225	1-249-425-11	CARBON 4.7K	5% 1/4W (EXCEPT KE200)
R231	1-249-425-11	CARBON 4.7K	5% 1/4W (EXCEPT KE200)
R232	1-247-822-11	CARBON 430	5% 1/4W (EXCEPT KE200)

MAIN**AC POWER SW****PANEL****POWER SW****REC VOL****TRANSFORMER****HP**

Ref. No.	Part No.	Description		Remark	Ref. No.	Part No.	Description		Remark
R233	1-247-866-11	CARBON	30K	5% 1/4W (EXCEPT KE200)	R526	1-249-429-11	CARBON	10K	5% 1/4W (RX300)
R234	1-249-435-11	CARBON	33K	5% 1/4W	R527	1-249-426-11	CARBON	5.6K	5% 1/4W (EXCEPT KE200)
R235	1-249-439-11	CARBON	68K	5% 1/4W	R528	1-249-422-11	CARBON	2.7K	5% 1/4W (EXCEPT KE200)
R236	1-249-410-11	CARBON	270	5% 1/4W	R529	1-249-429-11	CARBON	10K	5% 1/4W
R241	1-249-432-11	CARBON	18K	5% 1/4W	R530	1-249-421-11	CARBON	2.2K	5% 1/4W
R242	1-249-432-11	CARBON	18K	5% 1/4W	R531	1-249-427-11	CARBON	6.8K	5% 1/4W (KE300,KE400S)
R243	1-249-423-11	CARBON	3.3K	5% 1/4W	R531	1-249-426-11	CARBON	5.6K	5% 1/4W (RX300)
R244	1-247-848-11	CARBON	5.1K	5% 1/4W	R532	1-249-433-11	CARBON	22K	5% 1/4W (KE300,KE400S)
R245	1-249-409-11	CARBON	220	5% 1/4W	R532	1-247-862-11	CARBON	20K	5% 1/4W (RX300)
R251	1-249-433-11	CARBON	22K	5% 1/4W	R535	1-249-419-11	CARBON	1.5K	5% 1/4W (KE300,KE400S)
R252	1-249-417-11	CARBON	1K	5% 1/4W	R536	1-249-421-11	CARBON	2.2K	5% 1/4W (EXCEPT KE200)
R253	1-249-441-11	CARBON	100K	5% 1/4W	R537	1-247-866-11	CARBON	30K	5% 1/4W (EXCEPT KE200)
R254	1-249-433-11	CARBON	22K	5% 1/4W	R538	1-247-852-11	CARBON	7.5K	5% 1/4W (EXCEPT KE200)
R502	1-215-452-00	METAL	20K	1% 1/4W	R539	1-249-431-11	CARBON	15K	5% 1/4W (EXCEPT KE200)
R503	1-249-422-11	CARBON	2.7K	5% 1/4W	R540	1-247-874-11	CARBON	62K	5% 1/4W (EXCEPT KE200)
R504	1-215-455-00	METAL	27K	1% 1/4W	R541	1-249-429-11	CARBON	10K	5% 1/4W (EXCEPT KE200)
R505	1-249-417-11	CARBON	1K	5% 1/4W (EXCEPT KE200)	R542	1-249-429-11	CARBON	10K	5% 1/4W (EXCEPT KE200)
R506	1-249-429-11	CARBON	10K	5% 1/4W (RX300)	R543	1-249-429-11	CARBON	10K	5% 1/4W (EXCEPT KE200)
R507	1-249-440-11	CARBON	82K	5% 1/4W (RX300)	R544	1-249-429-11	CARBON	10K	5% 1/4W (EXCEPT KE200)
R512	1-249-421-11	CARBON	2.2K	5% 1/4W (EXCEPT KE200)	R553	1-249-437-11	CARBON	47K	5% 1/4W
R513	1-249-441-11	CARBON	100K	5% 1/4W (EXCEPT KE200)	R555	1-249-427-11	CARBON	6.8K	5% 1/4W
R514	1-249-441-11	CARBON	100K	5% 1/4W (EXCEPT KE200)	R556	1-249-423-11	CARBON	3.3K	5% 1/4W
R515	1-249-436-11	CARBON	39K	5% 1/4W (EXCEPT KE200)	R557	1-249-441-11	CARBON	100K	5% 1/4W
R516	1-249-425-11	CARBON	4.7K	5% 1/4W (EXCEPT KE200)	R558	1-249-429-11	CARBON	10K	5% 1/4W
R517	1-249-433-11	CARBON	22K	5% 1/4W (EXCEPT KE200)	R559	1-249-441-11	CARBON	100K	5% 1/4W
R518	1-249-425-11	CARBON	4.7K	5% 1/4W (EXCEPT KE200)	R560	1-249-417-11	CARBON	1K	5% 1/4W
R521	1-249-426-11	CARBON	5.6K	5% 1/4W (KE300,KE400S)	R561	1-249-432-11	CARBON	18K	5% 1/4W
R521	1-247-852-11	CARBON	7.5K	5% 1/4W (RX300)	R562	1-249-436-11	CARBON	39K	5% 1/4W
R522	1-249-426-11	CARBON	5.6K	5% 1/4W (KE300,KE400S)	R563	1-247-848-11	CARBON	5.1K	5% 1/4W (KE200)
R522	1-247-852-11	CARBON	7.5K	5% 1/4W (RX300)	R564	1-247-834-11	CARBON	1.3K	5% 1/4W (KE200)
R523	1-247-858-11	CARBON	13K	5% 1/4W (EXCEPT KE200)	R565	1-249-430-11	CARBON	12K	5% 1/4W (KE200)
R524	1-247-852-11	CARBON	7.5K	5% 1/4W (RX300)	R567	1-249-433-11	CARBON	22K	5% 1/4W (KE200)
R525	1-247-854-11	CARBON	9.1K	5% 1/4W (KE300,KE400S)	R572	1-249-429-11	CARBON	10K	5% 1/4W
R525	1-249-429-11	CARBON	10K	5% 1/4W (RX300)	R573	1-249-429-11	CARBON	10K	5% 1/4W
R526	1-247-854-11	CARBON	9.1K	5% 1/4W (KE300,KE400S)					

MAIN	AC POWER SW	PANEL	POWER SW	REC VOL	TRANSFORMER	HP
-------------	--------------------	--------------	-----------------	----------------	--------------------	-----------

Ref. No.	Part No.	Description		Remark	Ref. No.	Part No.	Description		Remark
R574	1-249-435-11	CARBON	33K	5% 1/4W (EXCEPT KE200)	R815	1-247-807-31	CARBON	100	5% 1/4W
R575	1-247-807-31	CARBON	100	5% 1/4W	R816	1-247-807-31	CARBON	100	5% 1/4W
R576	1-249-435-11	CARBON	33K	5% 1/4W (KE400S)	R820	1-247-807-31	CARBON	100	5% 1/4W
R577	1-249-429-11	CARBON	10K	5% 1/4W	R821	1-249-429-11	CARBON	10K	5% 1/4W
R578	1-249-433-11	CARBON	22K	5% 1/4W	R822	1-249-429-11	CARBON	10K	5% 1/4W
R601	1-249-419-11	CARBON	1.5K	5% 1/4W	R823	1-249-429-11	CARBON	10K	5% 1/4W
R602	1-249-429-11	CARBON	10K	5% 1/4W	R824	1-249-421-11	CARBON	2.2K	5% 1/4W
R603	1-247-807-31	CARBON	100	5% 1/4W	R825	1-249-435-11	CARBON	33K	5% 1/4W
R604	1-249-433-11	CARBON	22K	5% 1/4W	R826	1-249-421-11	CARBON	2.2K	5% 1/4W
R605	1-249-433-11	CARBON	22K	5% 1/4W	R827	1-249-422-11	CARBON	2.7K	5% 1/4W
R606	1-249-430-11	CARBON	12K	5% 1/4W	R828	1-249-422-11	CARBON	2.7K	5% 1/4W
R607	1-249-433-11	CARBON	22K	5% 1/4W	R829	1-249-422-11	CARBON	2.7K	5% 1/4W
R608	1-247-862-11	CARBON	20K	5% 1/4W	R830	1-249-429-11	CARBON	10K	5% 1/4W
R609	1-249-429-11	CARBON	10K	5% 1/4W	R831	1-249-429-11	CARBON	10K	5% 1/4W
R701	1-249-425-11	CARBON	4.7K	5% 1/4W	R832	1-249-437-11	CARBON	47K	5% 1/4W
R702	1-249-419-11	CARBON	1.5K	5% 1/4W	R833	1-249-437-11	CARBON	47K	5% 1/4W
R703	1-249-418-11	CARBON	1.2K	5% 1/4W	R901	1-249-420-11	CARBON	1.8K	5% 1/4W
R704	1-249-427-11	CARBON	6.8K	5% 1/4W	R902	1-249-423-11	CARBON	3.3K	5% 1/4W
R705	1-249-419-11	CARBON	1.5K	5% 1/4W	R903	1-249-426-11	CARBON	5.6K	5% 1/4W
R706	1-249-419-11	CARBON	1.5K	5% 1/4W	R904	1-249-429-11	CARBON	10K	5% 1/4W
R707	1-249-429-11	CARBON	10K	5% 1/4W	R905	1-249-435-11	CARBON	33K	5% 1/4W
R708	1-249-425-11	CARBON	4.7K	5% 1/4W	R906	1-249-420-11	CARBON	1.8K	5% 1/4W
R709	1-249-409-11	CARBON	220	5% 1/4W	R907	1-249-423-11	CARBON	3.3K	5% 1/4W
R710	1-249-417-11	CARBON	1K	5% 1/4W	R908	1-249-426-11	CARBON	5.6K	5% 1/4W
R711	1-249-427-11	CARBON	6.8K	5% 1/4W	R909	1-249-429-11	CARBON	10K	5% 1/4W (RX300)
R712	1-249-427-11	CARBON	6.8K	5% 1/4W	R910	1-249-435-11	CARBON	33K	5% 1/4W (RX300)
R713	1-249-421-11	CARBON	2.2K	5% 1/4W	R912	1-247-807-31	CARBON	100	5% 1/4W
R714	1-249-425-11	CARBON	4.7K	5% 1/4W (US,CND,E)	R913	1-249-429-11	CARBON	10K	5% 1/4W
R715	1-249-421-11	CARBON	2.2K	5% 1/4W	R921	1-249-430-11	CARBON	12K	5% 1/4W (KE400S)
R716	1-249-437-11	CARBON	47K	5% 1/4W	R921	1-247-836-11	CARBON	1.6K	5% 1/4W (EXCEPT KE400S)
R717	1-249-429-11	CARBON	10K	5% 1/4W	R922	1-249-427-11	CARBON	6.8K	5% 1/4W (KE400S)
R718	1-247-870-11	CARBON	43K	5% 1/4W	R922	1-249-421-11	CARBON	2.2K	5% 1/4W (EXCEPT KE400S)
R719	1-249-429-11	CARBON	10K	5% 1/4W	R923	1-249-423-11	CARBON	3.3K	5% 1/4W
R801	1-249-417-11	CARBON	1K	5% 1/4W	R924	1-247-868-11	CARBON	36K	5% 1/4W (KE400S)
R802	1-249-441-11	CARBON	100K	5% 1/4W	R924	1-249-427-11	CARBON	6.8K	5% 1/4W (KE300,RX300)
R803	1-249-429-11	CARBON	10K	5% 1/4W	R925	1-247-836-11	CARBON	1.6K	5% 1/4W (KE400S)
R805	1-249-434-11	CARBON	27K	5% 1/4W	R926	1-249-421-11	CARBON	2.2K	5% 1/4W (KE400S)
R806	1-249-434-11	CARBON	27K	5% 1/4W (EXCEPT KE200)	< VARIABLE RESISTOR >				
R807	1-249-434-11	CARBON	27K	5% 1/4W (EXCEPT KE200)	RV111	1-241-630-11	RES. ADJ. CARBON 10K (RECORD LEVEL L)		
R808	1-249-434-11	CARBON	27K	5% 1/4W (EXCEPT KE200)	RV211	1-241-630-11	RES. ADJ. CARBON 10K (RECORD LEVEL R)		
R809	1-249-434-11	CARBON	27K	5% 1/4W (EXCEPT KE200)	RV901	1-223-604-11	RES. VAR. CARBON 10K/10K (REC LEVEL)		
R810	1-247-807-31	CARBON	100	5% 1/4W	RV902	1-223-605-11	RES. VAR. CARBON 20K/20K (BALANCE)		
R811	1-247-807-31	CARBON	100	5% 1/4W					
R812	1-247-807-31	CARBON	100	5% 1/4W					
R813	1-247-807-31	CARBON	100	5% 1/4W					
R814	1-247-807-31	CARBON	100	5% 1/4W					

MAIN AC POWER SW PANEL POWER SW REC VOL TRANSFORMER HP

Ref. No.	Part No.	Description	Remark
		< SWITCH >	
S901	1-554-303-21	SWITCH, TACTILE (■ PAUSE)	
S902	1-554-303-21	SWITCH, TACTILE (◀◀ ▷ AMS ▶▶) (RX300)	
S903	1-554-303-21	SWITCH, TACTILE (◀◀ ▷ AMS ▶▶) (EXCEPT RX300)	
S904	1-554-303-21	SWITCH, TACTILE (◀◀ ▷ AMS ▶▶) (RX300)	
S905	1-554-303-21	SWITCH, TACTILE (○ REC MUTE)	
S906	1-554-303-21	SWITCH, TACTILE (RESET)	
S907	1-554-303-21	SWITCH, TACTILE (MEMORY)	
S908	1-554-303-21	SWITCH, TACTILE (■)	
S909	1-554-303-21	SWITCH, TACTILE (◀◀)	
S910	1-554-303-21	SWITCH, TACTILE (▶▶)	
S911	1-554-303-21	SWITCH, TACTILE (● REC)	
S912	1-762-567-11	SWITCH, SLIDE (DIRECTION) (RX300)	
S921	1-554-303-21	SWITCH, TACTILE (AUTO CAL) (EXCEPT KE200)	
S922	1-762-647-11	SWITCH, ROTARY (DOLBY NR) (KE400S)	
S922	1-762-641-11	SWITCH, ROTARY (DOLBY NR) (KE300,RX300)	
S922	1-762-640-11	SWITCH, ROTARY (DOLBY NR) (KE200)	
△ S930	1-762-581-11	SWITCH, AC POWER PUSH (1 KEY) (POWER) (EXCEPT US,CND,E)	
S931	1-762-580-11	SWITCH, PUSH (1 KEY) (POWER) (US,CND,E)	
		< TRANSFORMER >	
△ T901	1-426-651-11	TRANSFORMER,POWER (KE200,KE300: EXCEPT E)	
△ T901	1-426-652-11	TRANSFORMER,POWER (KE300:E)	
△ T901	1-427-743-11	TRANSFORMER,POWER (RX300)	
△ T901	1-427-751-11	TRANSFORMER,POWER (KE400S:EXCEPT US)	
△ T901	1-427-752-11	TRANSFORMER,POWER (KE400S:US)	
		< TEST PIN >	
* TP801	1-560-060-00	PIN, CONNECTOR 2P	
		< VIBRATOR >	
X801	1-577-360-11	VIBRATOR, CERAMIC (6MHZ)	

MISCELLANEOUS *****			
△ 9	1-569-007-11	ADAPTER, CONVERSION 2P (KE300:E)	
56	1-773-287-11	WIRE (FLAT TYPE) (29 CORE)	
61	1-765-318-11	WIRE (FLAT TYPE) (7 CORE)	
67	1-769-947-11	WIRE (FLAT TYPE) (11 CORE)	
△ CNP901	1-558-945-21	CORD, POWER (POLAR.SPT-1)	
△ CNP901	1-575-651-21	CORD, POWER (AEP,G,MY,SP)	
△ CNP901	1-696-027-11	CORD, POWER (E)	
△ CNP901	1-696-845-11	CORD, POWER (AUS)	
△ CNP901	1-751-523-11	CORD, POWER (UK)	
FL901	1-517-173-11	INDICATOR TUBE, FLUORESCENT (KE200,KE300,RX300)	
FL901	1-517-374-11	INDICATOR TUBE, FLUORESCENT (KE400S)	

Ref. No.	Part No.	Description	Remark
HE901	1-543-673-11	HEAD, MAGNETIC (ERASE) (EXCEPT RX300)	
HRP901	1-543-919-11	HEAD,MAGNETIC (RECORD/PLAYBACK) (EXCEPT RX300)	
HRPE901A-2004-527-A		DECK ASSY, HEAD (RECORD/PLAYBACK/ERASE) (RX300)	
M901	X-3363-501-2	MOTOR ASSY,REEL (REEL)	
M902	X-3365-377-2	MOTOR ASSY,CAPSTAN (CAPSTAN)	
△ S701	1-570-046-21	SWITCH, VOLTAGE CHANGE (E)	
△ T901	1-426-651-11	TRANSFORMER, POWER (KE200,KE300:EXCEPT E)	
△ T901	1-426-652-11	TRANSFORMER, POWER (KE300:E)	
△ T901	1-427-743-11	TRANSFORMER, POWER (RX300)	
△ T901	1-427-751-11	TRANSFORMER, POWER (KE400S:EXCEPT US)	
△ T901	1-427-752-11	TRANSFORMER, POWER (KE400S:US)	

ACCESSORIES & PACKING MATERIALS *****			
	1-551-734-11	CORD, CONNECTION	
	3-856-130-11	MANUAL, INSTRUCTION (ENGLISH/FRENCH) (RX300)	
	3-856-134-11	MANUAL, INSTRUCTION (ENGLISH/FRENCH/ SPANISH/PORTUGUESE) (AEP)	
	3-856-134-21	MANUAL, INSTRUCTION (ENGLISH) (US,UK,AUS)	
	3-856-134-31	MANUAL, INSTRUCTION (GERMAN/DUTCH/ SWEDISH/ITALIAN)(AEP)	
	3-856-134-41	MANUAL, INSTRUCTION (GERMAN) (G)	
	3-856-134-51	MANUAL, INSTRUCTION (ENGLISH,FRENCH, SPANISH,CHINESE) (E,MY,SP)	
*	3-931-693-01	INDIVIDUAL CARTON (KE400S:US,AUS)	
*	3-932-083-01	CUSHION	
*	3-935-033-01	INDIVIDUAL CARTON (KE200)	
*	3-935-034-01	INDIVIDUAL CARTON (KE300:AEP,G,MY,SP)	
*	3-935-035-01	INDIVIDUAL CARTON (KE400S:AEP,UK,G)	
*	3-935-036-01	INDIVIDUAL CARTON (RX300)	
*	3-935-090-01	INDIVIDUAL CARTON (KE300:E,AUS)	

***** HARDWARE LIST *****			
#1	7-682-548-04	SCREW +BVTT 3X8 (S)	
#2	7-685-871-01	SCREW +BVTT 3X6 (S)	
#3	7-685-872-09	SCREW +BVTT 3X8 (S)	
#4	7-685-646-79	SCREW +BVTP 3X8 TYPE2 N-S	
#5	7-685-862-09	SCREW +BVTT 2.6X6 (S)	
#6	7-685-134-19	SCREW (+ PTPWH) (2.6X8)	
#7	7-621-775-00	SCREW +B 2.6X3	
#8	7-627-556-08	SCREW +P 2.6X2.8	
#9	7-621-772-58	SCREW (+B2X10) (EXCEPT RX300)	

The components identified by mark △ or dotted line with mark △ are critical for safety. Replace only with part number specified.	Les composants identifiés par une marque △ sont critiques pour la sécurité. Ne les remplacer que par une pièce portant le numéro spécifié
---	--