

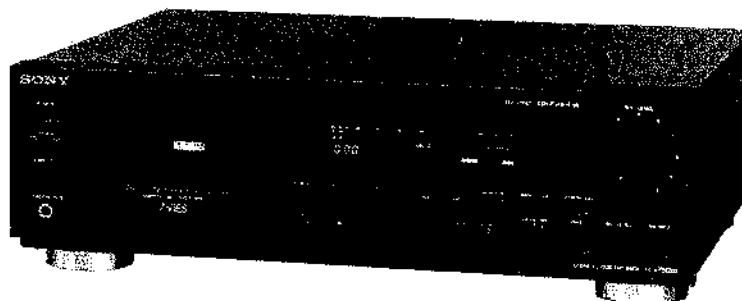

# TC-K750ES

## SERVICE MANUAL

AEP Model



Dolby noise reduction manufactured under license from Dolby Laboratories Licensing Corporation. "DOLBY" and the double-D symbol  are trademarks of Dolby Laboratories Licensing Corporation.

Model Name Using Similar Mechanism	TC-K950ES
Tape Transport Mechanism Type	TCM-200D3

### SPECIFICATIONS

Recording system 4-track 2-channel stereo  
 Bias AC bias  
 Heads Erase head × 1 (S & F head)  
 Recording head × 1 (Permalloy head)  
 Playback head × 1 (Permalloy head)  
 Motors Capstan motor × 1  
 (direct drive linear torque BSL motor)  
 Reel motor × 1 (DC motor)  
 Wow and flutter ± 0.07% W Peak (DIN)  
 Fast-forward and rewind time

Approx. 90 sec. (with C-60 cassette)

Frequency response (DOLBY NR OFF)

TYPE IV cassette (Sony METAL-ES)	20–21,000 Hz (±3 dB, DIN) 20–16,000 Hz (0VU recording)
TYPE II cassette (Sony UX-S)	20–19,000 Hz (±3 dB, DIN)
TYPE I cassette (Sony HF-S)	20–17,000 Hz (±3 dB, DIN)

Signal-to-noise ratio (at peak level)

Cassette	Dolby NR switch		
	OFF	B-TYPE ON	C-TYPE ON
TYPE IV (Sony METAL-ES)	60 dB	69 dB	75 dB
TYPE II (Sony UX-S)	59 dB	66 dB	74 dB
TYPE I (Sony HF-S)	57 dB	66 dB	72 dB

Total harmonic distortion

1.0% (with Sony METAL-ES cassette)

Inputs

Line inputs (phono jacks)	Sensitivity	77.5 mV (–20 dB)
	Input impedance	50k ohms

Outputs

Line outputs (phono jacks)	Rated output level	0.44 V (–5 dB) at a load impedance 47k ohms
	Load impedance	Over 10k ohms
Headphones (stereo phone jack)	Output level	0–2.5 mW at a load impedance of 32 ohms

General

Power requirements 220 or 240 V AC adjustable, 50/60 Hz  
 Power consumption 23 W  
 Dimensions Approx. 430 × 135 × 350 mm (w/h/d)  
 (17 × 5<sup>3</sup>/<sub>8</sub> × 13<sup>7</sup>/<sub>8</sub> inches)  
 Weight Approx. 6.9 kg (15 lbs 4 oz)

Supplied accessory Audio connecting cord (2)  
 Optional accessory Wireless remote control unit RM-J701

Design and specifications subject to change without notice.

Note

This appliance conforms with EEC Directive 87/308/EEC regarding interference suppression.

STEREO CASSETTE DECK  
**SONY**®

TABLE OF CONTENTS

<u>Section</u>	<u>Title</u>	<u>Page</u>
SPECIFICATIONS		1
<b>1. GENERAL</b>		3
<b>2. DISASSEMBLY</b>		4
<b>3. ADJUSTMENTS</b>		
3-1. Mechanical Adjustments		6
3-2. Electrical Adjustments		9
<b>4. DIAGRAMS</b>		
4-1. Semiconductor Lead Layouts		14
4-2. Circuit Boards Location		14
4-3. Block Diagram		15
4-4. IC Block Diagrams		18
4-5. Printed Wiring Boards		
- Main Section -		20
4-6. Schematic Diagram		
- Main Section -		25
4-7. Printed Wiring Boards		
- Panel Section -		30
4-8. Schematic Diagram		
- Panel section -		33
<b>5. EXPLODED VIEWS</b>		
5-1. Overall Section		35
5-2. Panel Section		36
5-3. Mechanism Section (1)		
(TCM-200D3)		37
5-4. Mechanism Section (2)		
(TCM-200D3)		38
<b>6. ELECTRICAL PARTS LIST</b>		39

**Flexible Circuit Board Repairing**



- Keep the temperature of the soldering iron around 270°C during repairing.
- Do not touch the soldering iron on the same conductor of the circuit board (within 3 times).
- Be careful not to apply force on the conductor when soldering or unsoldering.

**Notes on chip component replacement**

- Never reuse a disconnected chip component.
- Notice that the minus side of a tantalum capacitor may be damaged by heat.

Dolby noise reduction and HX Pro headroom extension manufactured under license from Dolby Laboratories Licensing Corporation. HX Pro originated by Bang & Olufsen.

**SAFETY-RELATED COMPONENT WARNING!!**

COMPONENTS IDENTIFIED BY MARK  OR DOTTED LINE WITH MARK  ON THE SCHEMATIC DIAGRAMS AND IN THE PARTS LIST ARE CRITICAL TO SAFE OPERATION. REPLACE THESE COMPONENTS WITH SONY PARTS WHOSE PART NUMBERS APPEAR AS SHOWN IN THIS MANUAL OR IN SUPPLEMENTS PUBLISHED BY SONY.

## SECTION 1 GENERAL

### LOCATION AND FUNCTION OF CONTROLS

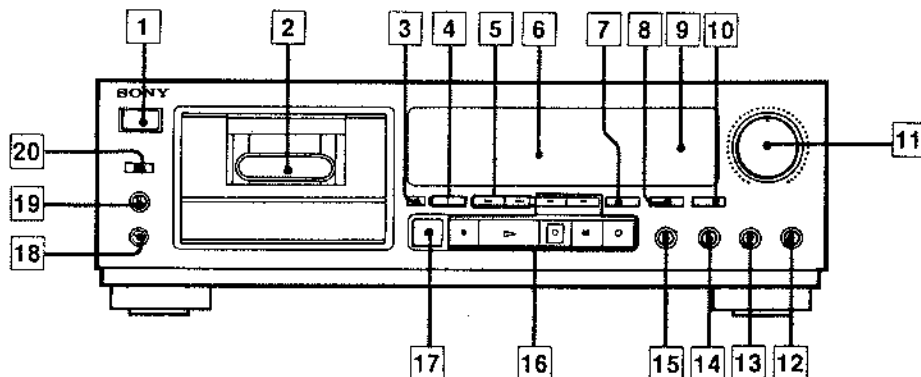

- |  |  |
|--|--|
| <p><b>1</b> POWER switch</p> <p><b>2</b> Cassette holder</p> <p><b>3</b> DISPLAY MODE button</p> <p><b>4</b> COUNTER buttons<br/>RESET button/MEMORY button</p> <p><b>5</b> I&lt;&lt;&lt; &gt;&gt;&gt; AMS (Automatic Music Sensor) buttons</p> <p><b>6</b> LINEAR COUNTER and PEAK PROGRAM METER</p> <p><b>7</b> MONITOR button</p> <p><b>8</b> MPX FILTER button</p> <p><b>9</b> Remote sensor*</p> <p><b>10</b> CALIBRATION button</p> <p><b>11</b> REC LEVEL (recording level) control</p> <p><b>12</b> BALANCE control</p> <p><b>13</b> REC LEVEL (recording level) control (for calibration)</p> | <p><b>14</b> BIAS (bias adjust) control</p> <p><b>15</b> DOLBY NR switch</p> <p><b>16</b> Tape operation buttons and indicators<br/>◀◀ (rewind) button<br/>■ (stop) button<br/>▶ (play) button and indicator<br/>▶▶ (fast-forward) button<br/>● REC (record) button and indicator<br/>   PAUSE button and indicator<br/>○ REC MUTE (record muting) button</p> <p><b>17</b> ▲ OPEN/CLOSE button</p> <p><b>18</b> HEADPHONES jack (stereo phone jack)</p> <p><b>19</b> PHONE LEVEL (headphone level) control</p> <p><b>20</b> TIMER switch</p> |
|--|--|

\* You can remotely control this cassette deck with:

- A remote commander that has an ■ mark and comes with a Sony amplifier or receiver and which can be used to control a cassette deck.
- An optional Sony remote commander that has an ■ mark.

## SECTION 2 DISASSEMBLY

NOTE: Follow the disassembly procedure in the numerical order given.

### CASSETTE HOLDER

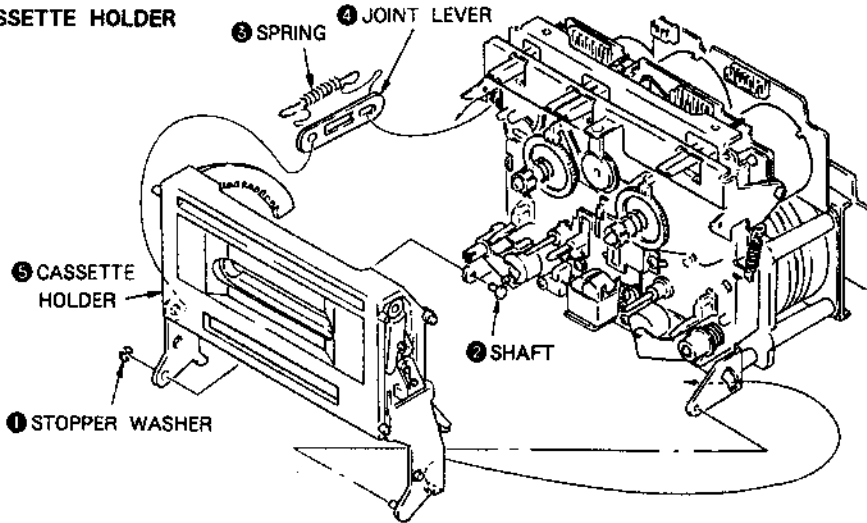

### ORNAMENTAL PLATE

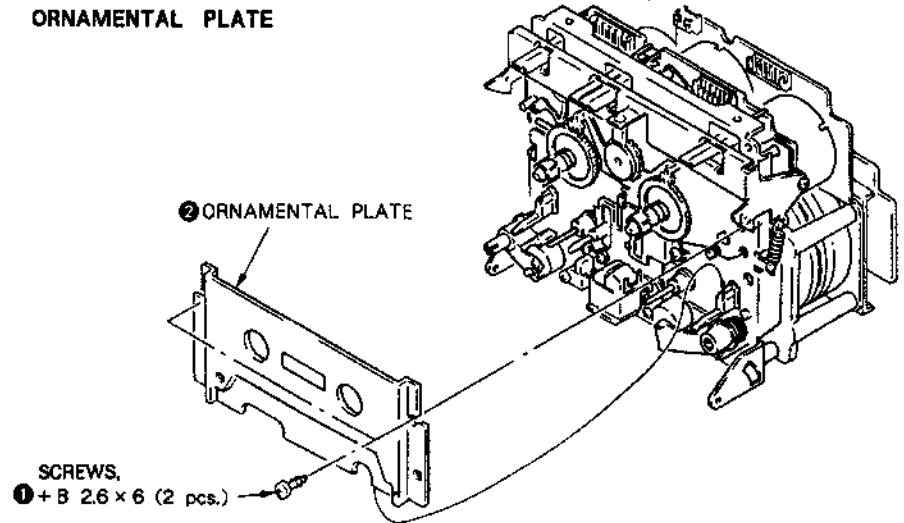

### PINCH LEVER/LEVER FR/HEAD

- ① - ④: PINCH LEVER S
- ①, ②: PINCH LEVER T
- ▲ ▲: LEVER FR

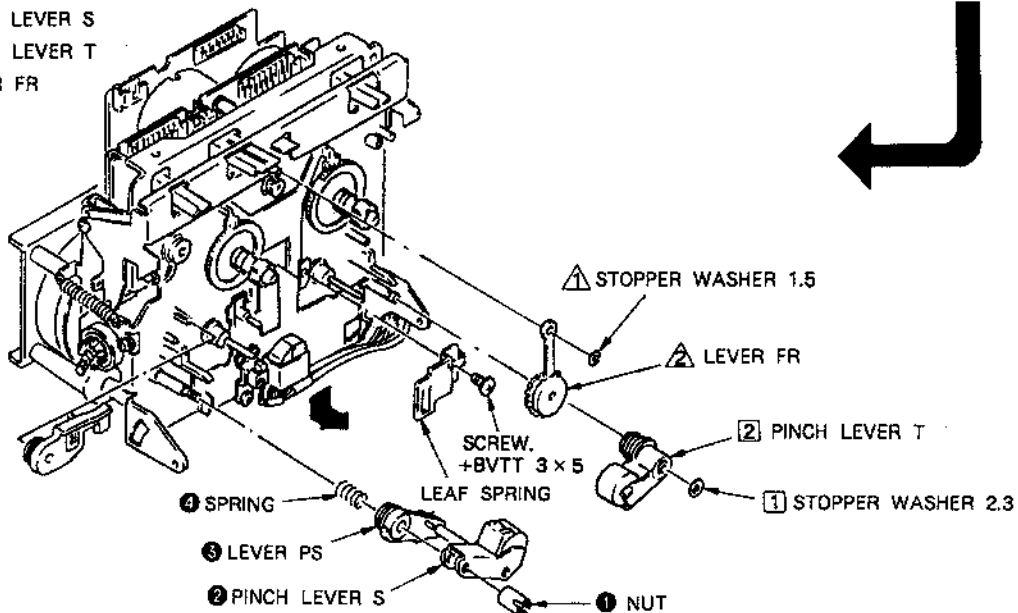

COMPARATOR BOARD/CAPSTAN BOARD/FLYWHEELS/FG BOARD

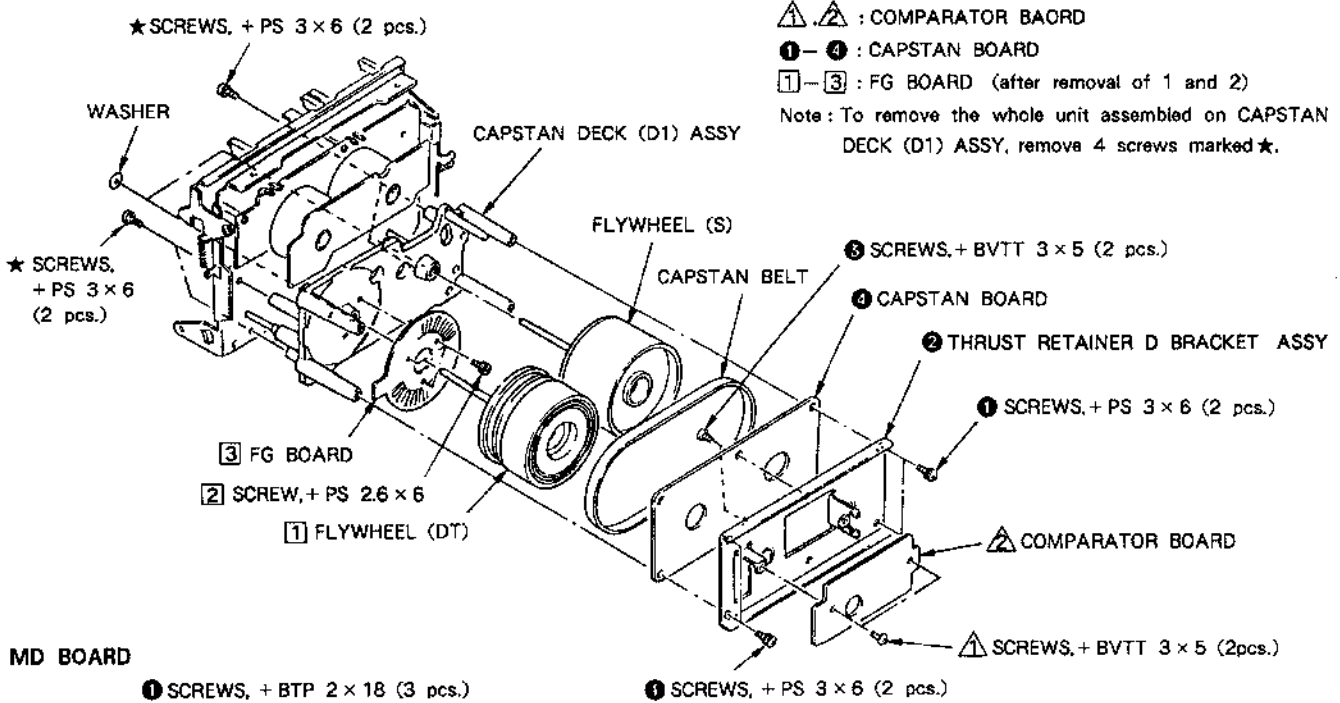

△ : COMPARATOR BOARD

1-4 : CAPSTAN BOARD

1-3 : FG BOARD (after removal of 1 and 2)

Note: To remove the whole unit assembled on CAPSTAN DECK (D1) ASSY, remove 4 screws marked ★.

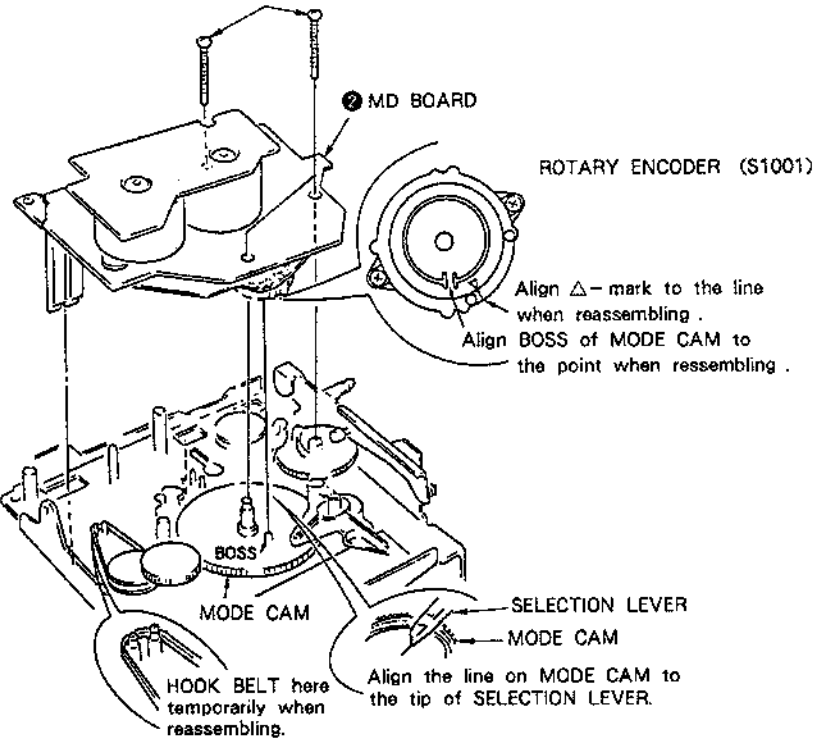

REEL MOTOR BOARD

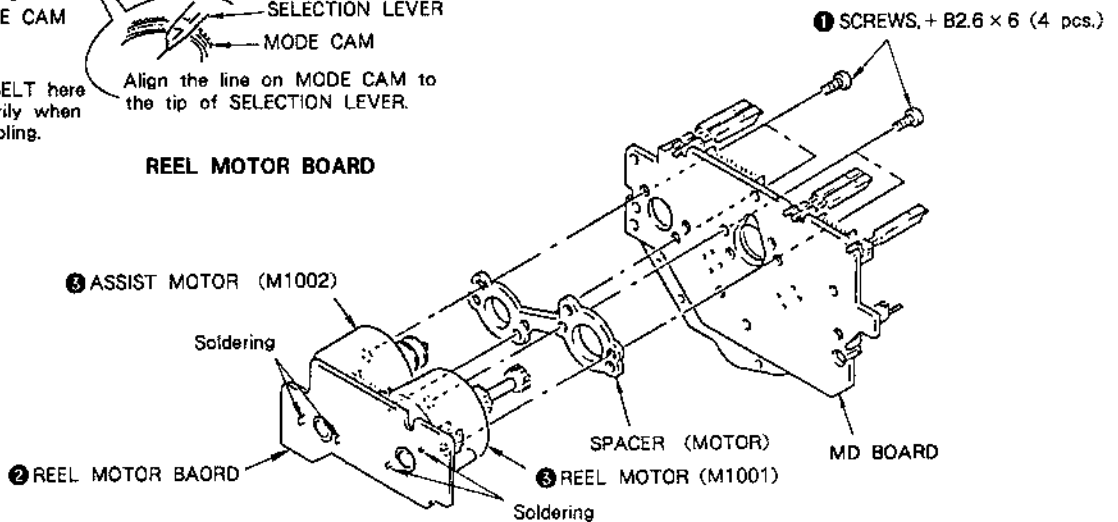

## SECTION 3 ADJUSTMENTS

### 3-1. MECHANICAL ADJUSTMENTS

#### PRECAUTION

1. Clean the following parts with a denatured-alcohol-moistened swab:
 

record/playback head	pinch roller
erase head	rubber belts
capstan	idlers
2. Demagnetize the record/playback and erase head with a head demagnetizer.
3. Do not use a magnetized screwdriver for the adjustments.
4. After the adjustments, apply suitable locking compound to the parts adjusted.
5. The adjustments should be performed with the rated power supply voltage unless otherwise noted.

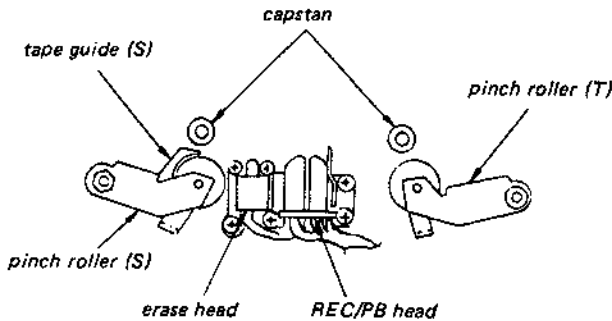

#### Pinch Roller Pressing Force Measurement

Mode : playback

Hook needle of the tension gauge to the pinch roller shaft and push back pinch roller to detach it from capstan. Then, return it gradually to capstan and read the gauge when the pinch roller begins turning.

#### Standard Limits :

Tape-up side : 270 - 350g (9.5 - 12oz)

Supply side : 180 - 280g (6.4 - 9.9oz)

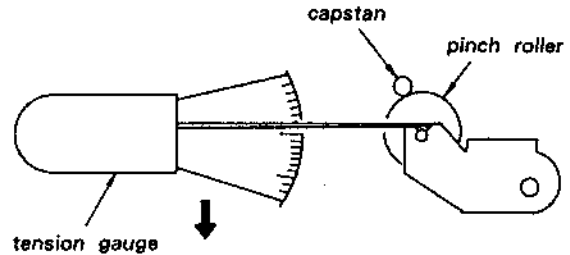

#### FLYWHEELS T/S THRUST ADJUSTMENT

1. FLYWHEEL T THRUST ADJUSTMENT :  
Insert 3mm - thick spacer gauge into the clearance between magnet of FLYWHEEL T and CAPSTAN Board, and adjust THRUST SCREW so that thrust play is 0.2 - 0.4mm .
2. FLYWHEELS THRUST ADJUSTMENT :  
Tighten THRUST SCREW lightly until the flywheel has no play and then loosen the screw by 1/2 - 3/4 turns.
3. After adjustments, apply locking compound to the screws.

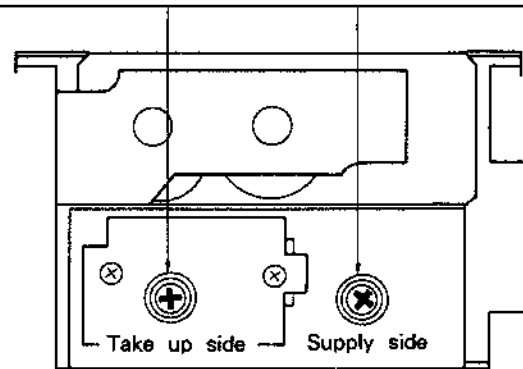
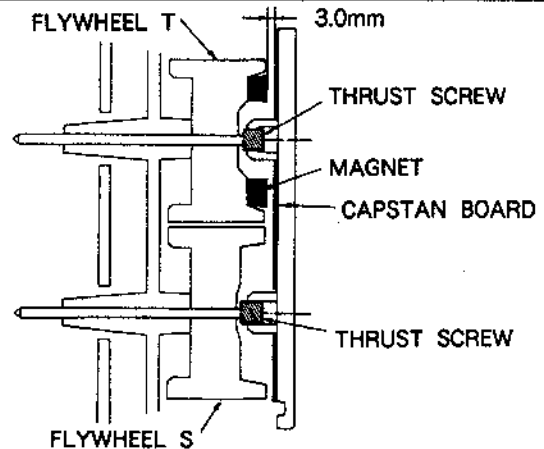

REAR VIEW OF MECHANISM

### Tape Path Adjustment

- Refer to Adjustment Position on page 10.

**Note:** When using the adjustment methods for other than replacement reasons, please do not tamper unnecessarily with the adjustment screws or the erasehead because either the supply pinch roller guide or the record/playback head will be made the standard tape paths. Moreover, when it is necessary to adjust and replace two or more of any of the heads and/or pinch rollers, replace them one by one, completely taking out the first tape path, and then replacing the second one.

#### Preparation :

1. Mirror cassette CQ009C 8-909-708-01  
(or CQ012C 8-909-708-02)

If one does not have this, cut out the sections of a 120-minute cassette shell as indicated below and use that cassette.

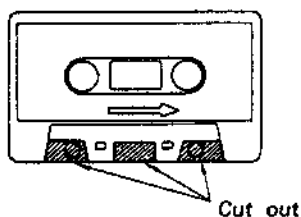

2. Phillips screwdriver (medium-size):  
For the head adjustment screws  
Blade-type screwdriver (large-size):  
For the supply pinch roller adjustment screws
3. Pen light
4. WS-48B (3 kHz, 0 dB)
5. P-4-A100 (10 kHz, -10 dB)

**Definition of Terms:** The figures are of a record/playback head.

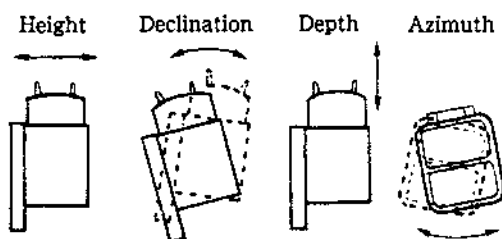

#### Adjustment Method :

##### Supply Pinch Roller

**Note:** Only perform this adjustment when the supply pinch roller is to be replaced.

1. Insert the mirror cassette and put the unit in record/playback mode.
2. Check to see whether the tape is curling at the record/playback head guide or the pinch roller guide.

If it is curling, remove the curl by adjusting the tape curl adjustment screw. Then, check that the tape is running past the middle of the erasehead.

##### Record/playback Head

**Note:** Only perform this adjustment when the record/playback head is to be replaced.

1. Insert the mirror cassette and put the unit in record/playback mode.
2. (**Height Adjustment**) Check to see if the tape is curling at the tape guide of the head. If it is curling, tighten screws A, B, and C, respectively by the same angle, moving the head so that it remains at the same angle throughout the procedure. If it curls on the bottom side of the mirror cassette (actually the inner side), tighten all the screws equally; but loosen them if the tape begins to curl on the top side (outer side).

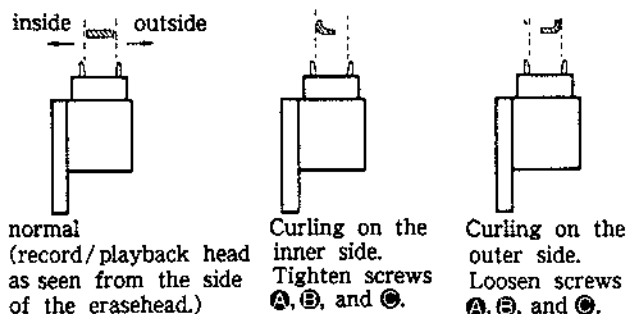

3. (**Declination Adjustment**) While in the record/playback position, set the back tension to 0 (wind the supply reel with something thin like a pencil in a counterclockwise direction) and make sure there is no curling or shifting (shifting up/shifting down) at the guide of the record/playback head.

Because shifting can only occur due to a difference in the width of the tape and that of the tape guides (curling will otherwise occur), it is necessary to pay close attention since it can be easily overlooked. When there is a shift, tighten screws B and C equally and change the declination of the head. If the tape is shifting up, tighten the screws, and if it is shifting down, loosen them.

4. Repeat the adjustments in steps 2 and 3 and fine adjust the height and the declination.

5. **(Preliminary Azimuth Adjustment)**

After demagnetizing and cleaning the adjustment head, play back WS-48B (3 kHz, 0 dB).

Turn screw ③ so that the reading on the level meter of the unit or that of the level meter connected to LINE OUT is maximized.

If the screw is turned at least half a revolution, repeat the adjustments from step 1.

6. **(Tape Path Check)** Connect the oscilloscope to LINE OUT and play back P-4-A100 (10 kHz, -10 dB) to display a resurge waveform. After 20 seconds of record/playback (after the tension within the loop has been increased sufficiently), make sure the variation in the resurge is within  $\pm 90$  degrees (within  $\pm 45$  degrees is desired). If the variation is greater than this, it is because the declination and/or the height adjustment is not perfect. Repeat the adjustments from step 1.

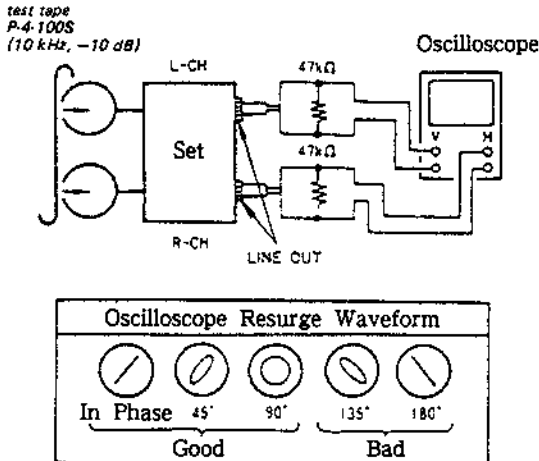

**Erasehead**

**Note:** Only perform this adjustment when the erasehead is to be replaced.

1. Insert the mirror cassette and put the unit in record/playback mode.
2. **(Azimuth Adjustment)** Adjust the azimuth of the erasehead by adjusting screws ⑤ and ⑥ so that the tape runs as evenly as possible.

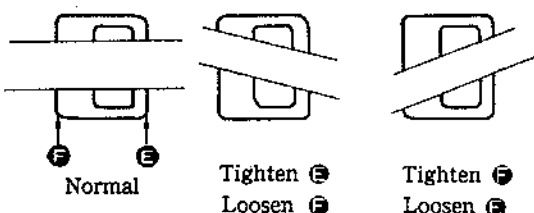

(The erasehead as seen when erasing the mirror cassette.)

3. **(Height adjustment)** Turn screws ⑦, ⑧, and ⑨ all by the same angle so that the portions of the erasehead visible at top and bottom are nearly of equal width. If the width at the top is greater, tighten the screws; if the width at the bottom is greater, loosen the screws.

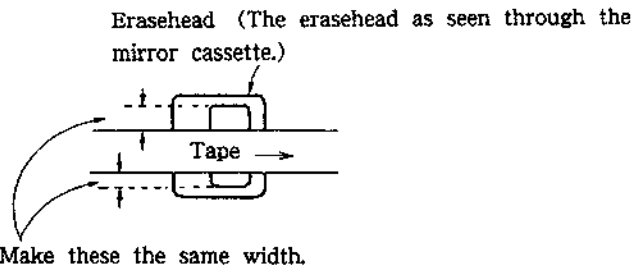

4. **(Declination Adjustment)** Leaving it in the playback position, put the back tension to 0 and make certain the erasehead part and supply pinch roller guide part do not shift. If there is a shift, turn the screw ⑩ and change the declination. Looking at it using the mirror cassette, if the tape shifts up, tighten the screw, and if it shifts down, loosen the screw.
5. Repeat the adjustments beginning with step 2 and fine adjust the height and declination. And make sure the tape does not curl up on the pinch roller guide or the guide part of the record/playback head.
6. **(Depth Adjustment)** In order to make the entire head play the tape smoothly, and to make sure the depth of the erasehead is neither too shallow nor too deep, loosen screw ⑪ a bit.

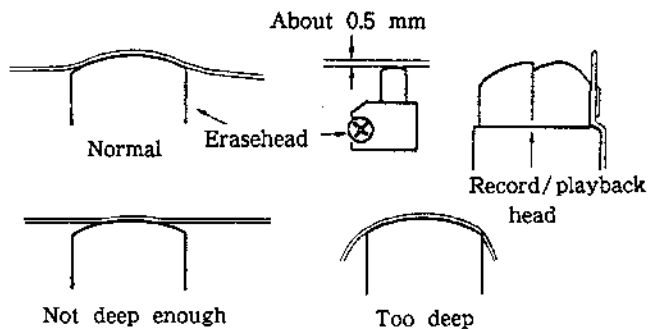

**Check**

1. Check to make sure that there are no curls or shifts throughout the whole tape path and that the tape runs smoothly.
2. Reapply the locking compound to the adjusted screws. (The locking compound should only be applied to screw ③ after the azimuth has been adjusted.)



**Adjustment Position :** As seen from the cassette, side (top) and MD as seen head on (bottom).

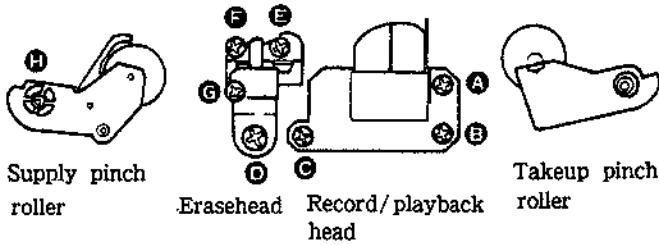
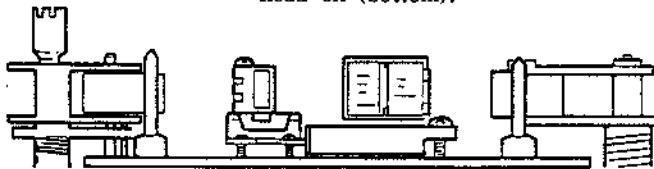

Supply pinch roller

Erasehead Record/playback head

Takeup pinch roller

### 3-2. ELECTRICAL ADJUSTMENTS

**Note:** The adjustment should be performed in the order given in this service manual.

The adjustments should be performed for both L-CH and R-CH.

• **Simultaneous REC/PB Mode:**

Input the signals to LINE IN terminal and set to REC mode. Set the monitor switch to TAPE, and monitor the recorded signal from LINE OUT terminal.

• **Switch Position:**

- DOLBY NR..... OFF
- MPX FILTER..... OFF
- TIMER..... OFF
- MONITOR..... TAPE
- CALIBRATION..... OFF
- BIAS..... CENTER CLICK
- REC LEVEL..... CENTER CLICK
- BALANCE..... CENTER CLICK

• **Standard Record:**

Deliver the standard input signal level to the input jack and set the REC LEVEL control to obtain the standard output signal level.

Standard Input Level

Input Terminal	LINE IN
source impedance	10 kΩ
input level	0.25 V (-10 dB)

Standard Output Level

Output Terminal	LINE OUT
load impedance	47 kΩ
output level	0.44 V (-5 dB)

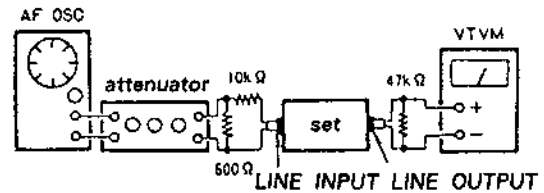

### Torque Adjustment and Measurement

1. Load a torque meter cassette CQ-102C and push ► button.
2. Adjust RV803 so that the reading on the torque meter is  $40 \pm 3g \cdot cm$  ( $0.56 \pm 0.042oz \cdot inch$ ).
3. After the adjustment, apply suitable locking compound to RV803.

Torque	Torque Meter	Reading
FWD	CQ-102C	$37 - 43g \cdot cm$ ( $0.51 - 0.60oz \cdot inch$ )
FWD Back tension	CQ-102C	$8 - 10.5g \cdot cm$ ( $0.11 - 0.15oz \cdot inch$ )
FF/REW	CQ-201B	$70 - 120g \cdot cm$ ( $0.97 - 1.67oz \cdot inch$ )

### Playback Head Azimuth Adjustment

**Procedure:**

1. Mode: playback

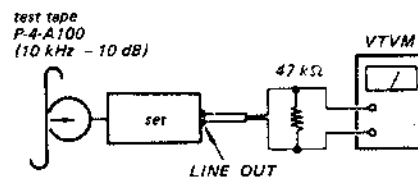

2. Turn the adjustment screw for the maximum output levels. If these levels do not match, turn the adjustment screw until both of output levels match together within 1dB.

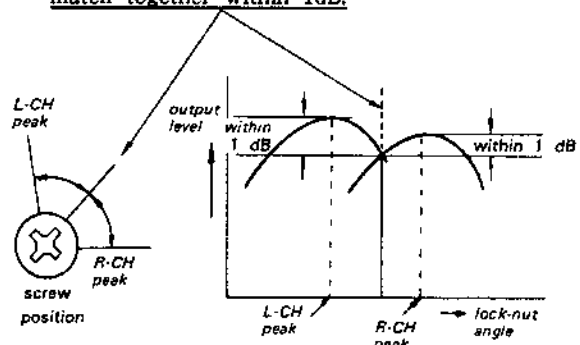

3. Phase check

By the means of 6. Tape Path check on page 8 confirm that phase difference is proper.

4. After the adjustment, lock the adjustment screw with locking compound.

Adjustment Location :

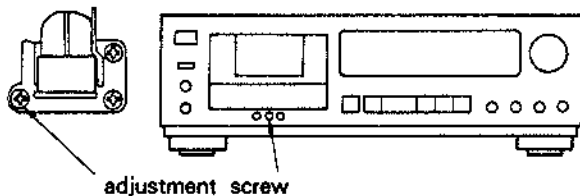

Tape Speed/WOW Check

Procedure:

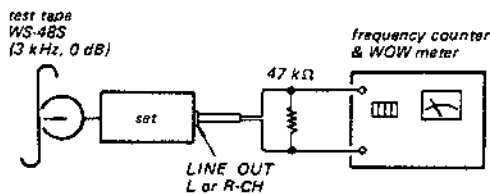

1. Measure the output frequency and the WOW value while playing back the tape top of the test tape.
2. Turn over the test tape, measure the output frequency and the WOW value, and check the difference from the values of the step 1.

Adjustment Limits :

TAPE SPEED deviation:	within 2,990 to 3,010 Hz
TAPE SPEED fluctuating width:	within 2,990 to 3,010 Hz
WOW (WRMS):	0.04% or less

Playback Level Adjustment

Procedure:

Mode: playback

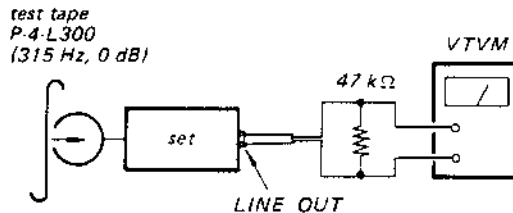

Adjust RV101 (L-CH) and RV201 (R-CH) to obtain the specified LINE OUT level.

Adjustment Limits :

- LINE OUT level: 0.41 to 0.46 V (-5.5 to -4.5 dB)
- Level difference between channels: less than 0.5 dB

Check that the LINE OUT level does not change in playback mode while changing the mode from playback to stop several times.

PB DOLBY NR Check

Procedure:

1. Mode: playback

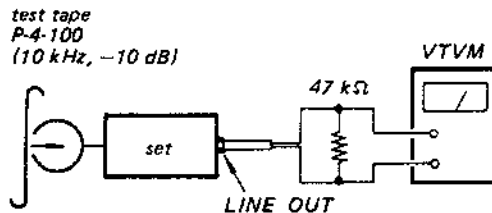

2. Make sure that the output levels are different in DOLBY NR OFF, B, and C.

Adjustment Limits :

- OFF → B level difference -1 to -3 dB
- B → C level difference 1 to 3 dB

Meter Level Check

1. Apply 315 Hz 0.245V (-10dB) signal to LINE IN and adjust REC VOL so that LINE OUT level is 0.436V (-5dB), and then confirm that 0 VU segments in level meter light or flicker.
2. Adjust REC VOL, to obtain 2.19V (9dB) output at LINE OUT and confirm that all segments in level meter light clearly.

**MPX FILTER Check**

**Setting :** DOLBY switch : OFF

**Procedure :**

1. Mode: stop

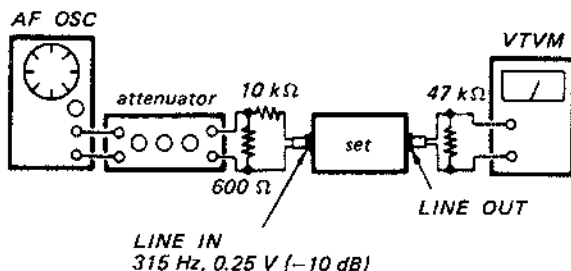

2. Apply 315 Hz, 0.25 V (-10 dB) signal and adjust REC LEVEL control so that the LINE OUT level is 0.44 V (-5 dB).
3. Set DOLBY switch to B or C and MPX FILTER switch ON. Confirm that the LINE OUT level is 0.39V to 0.49V (-5dB ± 1dB).
4. Apply 19kHz 0.25V (-10dB) signal and confirm that the LINE OUT level is 0.014V (-35dB) or less.

**Adjustment Limits :**

LINE OUT level

315Hz 0.39V - 0.49V (-5dB ± 1dB)

19kHz 0.014V (-35dB)

**Erase Current Adjustment**

1. Mode : record

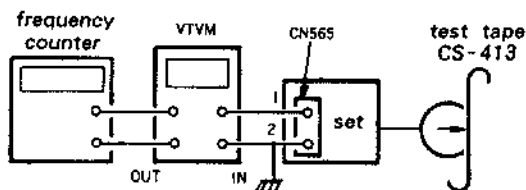

2. Adjust RV573 so that the reading on VTVM is 105mV (erase current=105mA).
3. And then confirm that the reading on the frequency counter is 160kHz.

**Adjustment Limits :**

Erase current : 105mA to 110mA

Frequency : 160 ± 6kHz

**Bias Current Adjustment**

**Note :** This adjustment should be made before Record Bias Adjustment.

Setting : HX PRO switch : ON

**Procedure :**

1. Preset RV152 (L-CH), RV252 (R-CH) and RV574 in the center position, and record with no signal.
2. Adjust T151 (L-CH) and T251 (R-CH) for minimum readings on the digital voltmeter.

**Adjustment Limits :**

160mV or less. (reference)

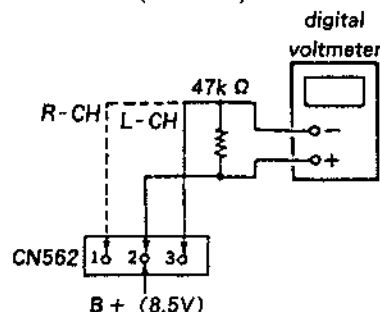

**Record Bias and Record Level Adjustment**

**Setting:**

REC LEVEL knob: standard record position  
(See page 9.)

**Procedure:**

1. Mode: simultaneous REC/PB

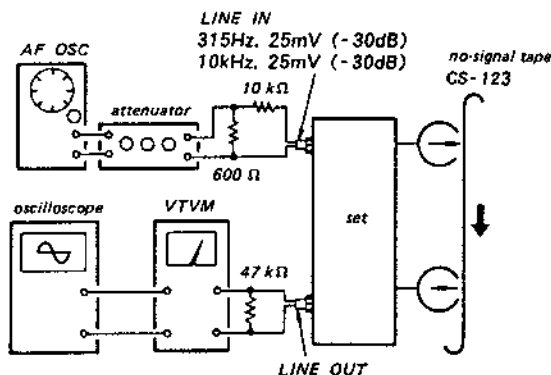

2. Adjust RV153 (L-CH) and RV253 (R-CH) so that the playback output level of 10kHz signal is 0.2dB to 0.8dB with respect to that of 315Hz. . . . Record Bias Adjustment.
3. Adjust RV151 (L-CH) and RV251 (R-CH) so that the playback output level of 315Hz is -25.3dB to -24.7dB. . . . Record Level Adjustment.

**Metal Bias Adjustment**

**Setting :**

REC LEVEL Knob : standard record position  
(See page 9.)

**Procedure :**

1. Mode : simultaneous REC/PB

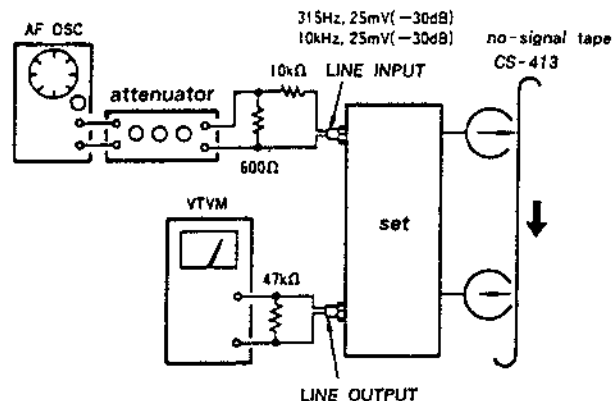

2. Adjust RV574 so that the playback output level of 10kHz in R-CH is 0.2dB to 0.8dB with respect to that of 315Hz.

**Calibration Meter Adjustment**

Setting : CALIBRATION switch : ON

**Procedure :**

1. Mode : stop

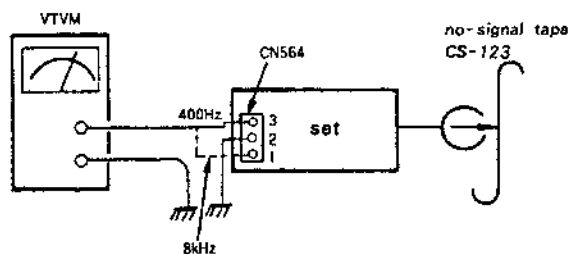

2. Adjust RV572 for 400Hz and RV571 for 8kHz to obtain oscillation level within  $10 \pm 0.5$ dBs respectively.
3. Put the set in record mode and adjust RV131 (HIGH) so that HIGH FREQ segments in the CAL LEVEL meter light thoroughly up to 0 VU as shown in the figure below. Segment (a) may flicker.
4. Preset RV231 (LOW) so that segment (a) in LOW FREQ CAL LEVEL meter lights. Then adjust RV231 to the point where segment (a) goes out.

HIGH : LEVEL (a) may flicker.

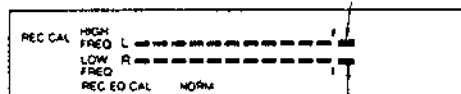

LOW : LEVEL (a) must not flicker.

**Rotation Detect Check**

1. Mode : FF or REW

Oscilloscope

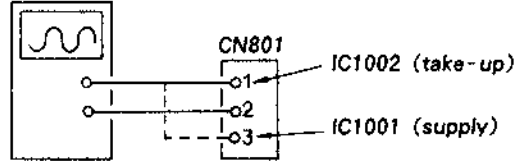

2. Waveform on the oscilloscope should be as shown below

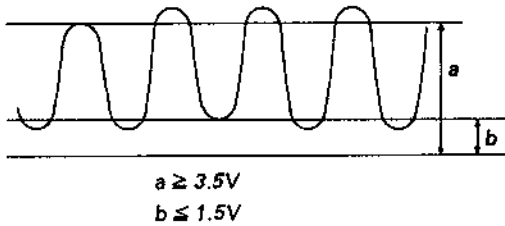

**Adjustment Parts Location :**

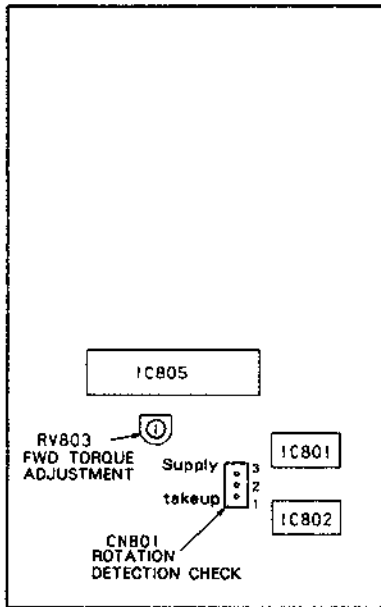

MAIN (B) BOARD  
- COMPONENT SIDE -

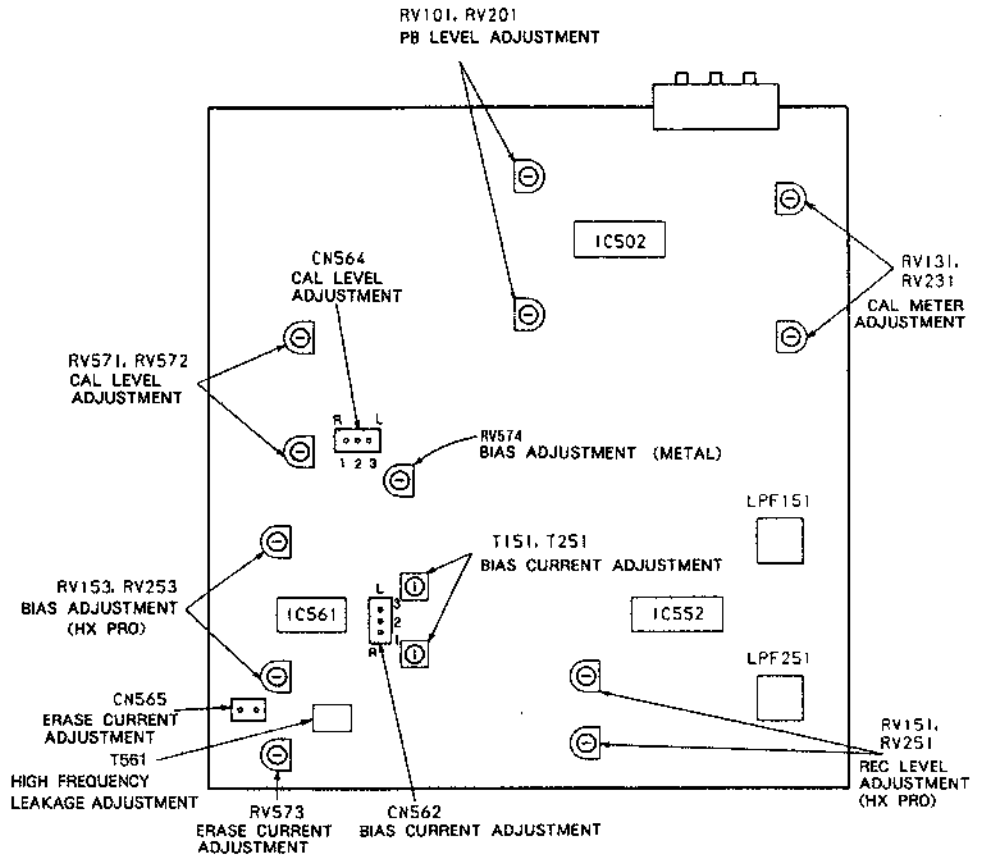

MAIN (A) BOARD - COMPONENT SIDE -

## SECTION 4 DIAGRAMS

### 4-1. SEMICONDUCTOR LEAD LAYOUTS

BA6219B

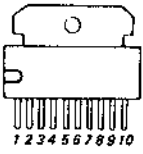

DTA114ES  
DTB114ES  
DTC114ES  
DTC144ES  
DTD114ES  
2SC2603EF  
2SC3623A-LK



2SA1116A-L  
2SA1409-LK  
2SC945-P  
2SC1815-Y



2SD2144S



GP2S22B



SEL1210S  
SEL1210S-C  
SEL1910A-C



LB1641

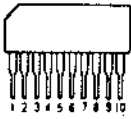

2SA1094-LK  
2SD1585-LK



2SA1175-HEF



2SK246-GR



OH009

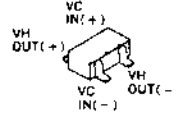

GP1U52XB



2SD1761-EF



HZS6C3L  
UZL-12H1  
UZP8.2BB  
1SS202-1

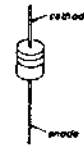

10E2N

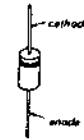

### 4-2. CIRCUIT BOARDS LOCATION

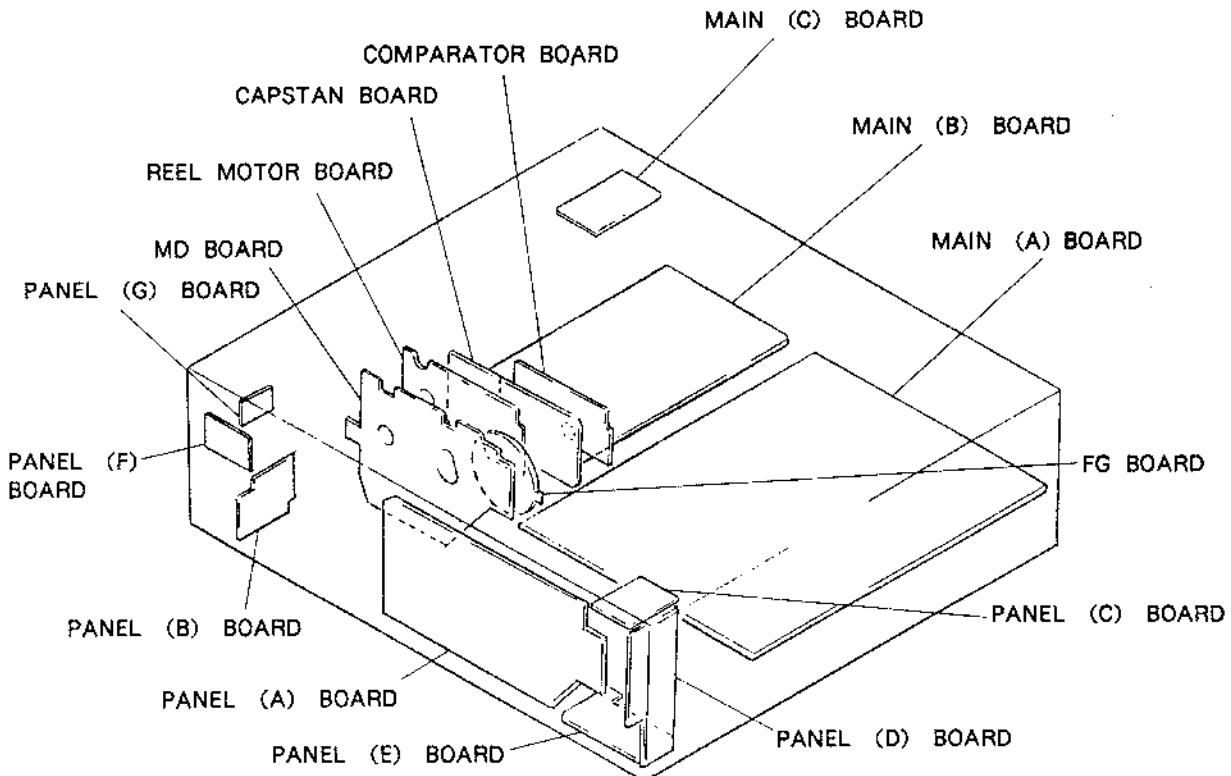

4-3. BLOCK DIAGRAM

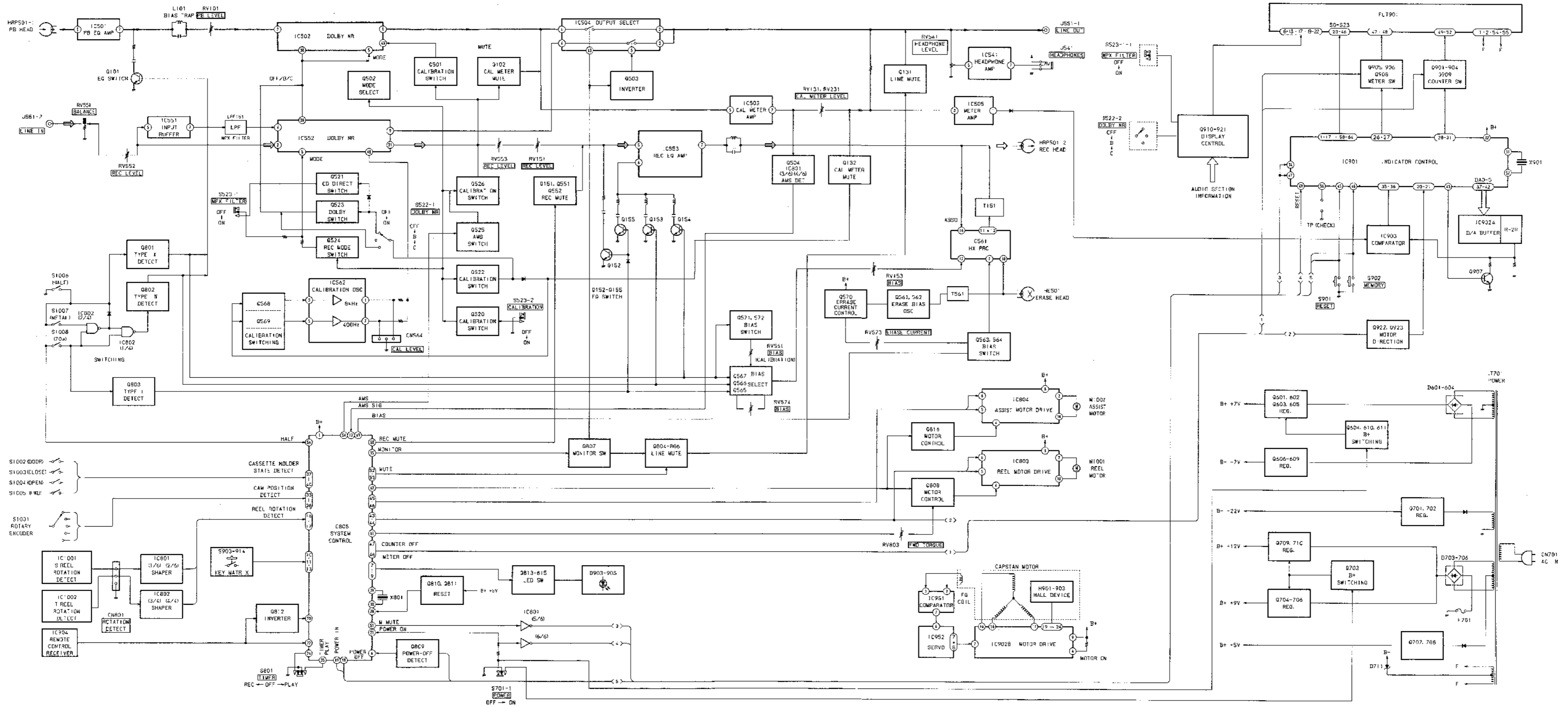

4-4. IC BLOCK DIAGRAMS

IC502, 552 CX20188

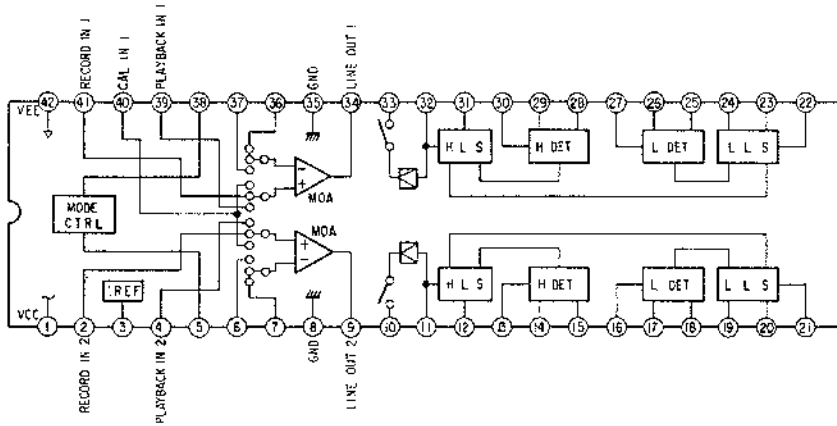

IC902B CX20174

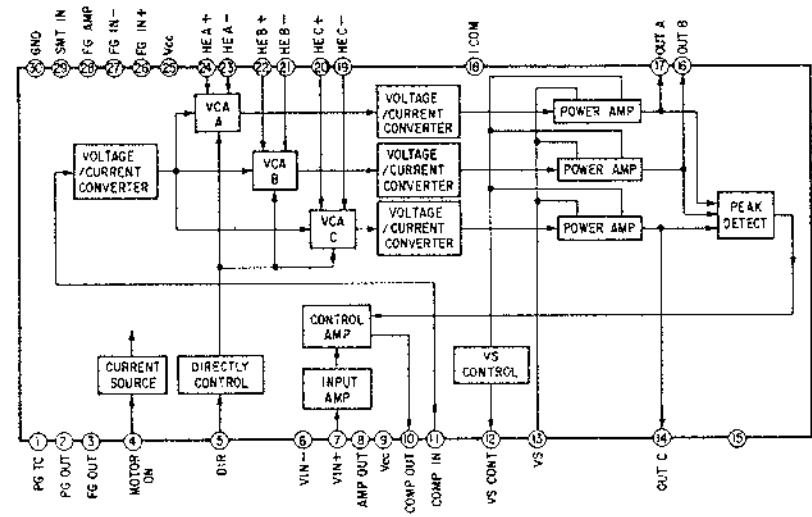

IC561  $\mu$ PC1297CA

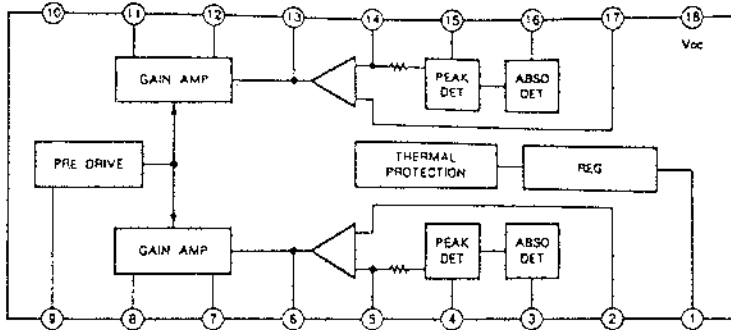

IC803 BA6219B  
IC804 LB1641

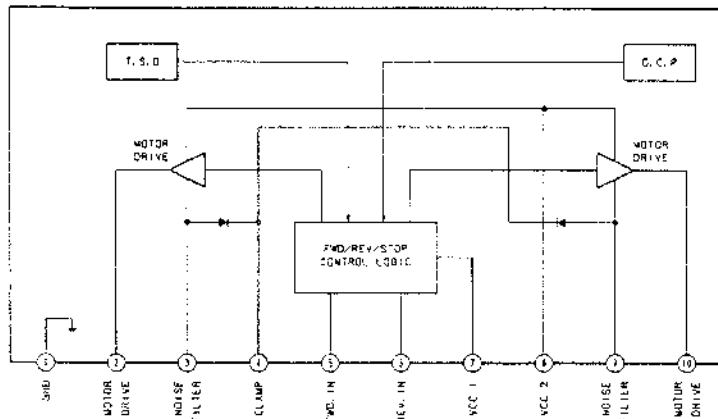

IC952 TC9142P

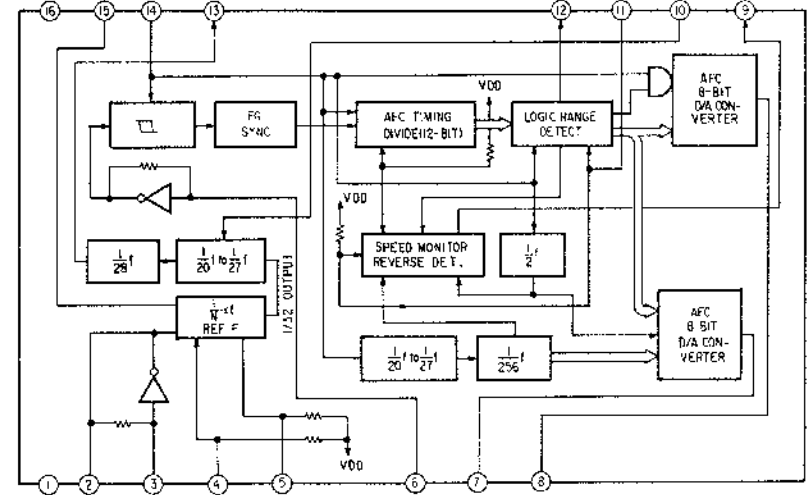

IC801, IC902A TC4069UBP

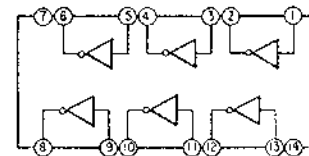



4-5. PRINTED WIRING BOARDS - MAIN SECTION -

• Semiconductor Location

Ref. No.	Location	Ref. No.	Location	Ref. No.	Location
0131	E-19	IC541	I-29	0583	I-27
0231	F-20	IC551	H-20	0584	I-27
0501	E-23	IC552	H-21	0585	G-26
0502	0-19	IC553	H-24	0586	G-26
0524	E-23	IC561	H-26	0587	G-26
0525	J-19	IC562	F-26	0588	E-27
0526	J-20	IC801	H-10	0589	F-27
0561	J-26	IC802	H-10	0570	J-26
0562	F-25	IC803	H-13	0571	J-25
0563	F-25	IC804	I-13	0572	J-25
0564	G-25	IC805	G-12	0601	E-25
0565	G-25	IC802B	C-5	0602	E-26
0566	G-25	IC851	G-3	0603	E-26
0601	D-27	IC852	F-2	0604	E-26
0602	D-27	IC1001	J-6	0605	D-25
0603	C-27	IC1002	J-5	0606	C-25
0604	C-27			0607	B-26
0605	E-25	Q101	E-24	0608	B-26
0606	E-26	Q102	D-21	0609	B-25
0607	F-26	Q131	E-20	0610	E-26
0701	C-12	Q132	E-19	0611	E-27
0702	C-13	Q151	H-23	Q701	C-12
0703	8-14	Q152	H-23	Q702	C-13
0704	8-13	Q153	H-24	Q703	D-10
0705	8-13	Q154	G-23	Q704	C-10
0706	8-13	Q155	G-23	Q705	C-10
0707	C-10	Q201	B-23	Q706	D-10
0708	C-13	Q202	C-21	Q707	E-10
0709	C-12	Q231	F-21	Q708	F-9
0710	E-10	Q232	G-20	Q709	E-9
0711	C-13	Q251	I-23	Q710	D-10
0712	E-10	Q252	I-23	Q801	I-11
0713	0-10	Q253	I-23	Q802	I-11
0714	0-10	Q254	I-23	Q803	I-11
0715	0-10	Q255	I-23	Q804	H-12
0716	0-14	Q501	B-24	Q805	H-12
0717	8-11	Q502	F-23	Q806	H-12
0801	I-10	Q503	F-22	Q807	G-12
0802	H-12	Q504	E-19	Q808	H-12
0803	H-12	Q523	J-21	Q809	F-11
0804	G-10	Q524	J-19	Q810	F-13
0805	H-13	Q525	G-23	Q811	F-13
0806	H-13	Q526	E-22	Q812	F-12
		Q551	G-23	Q813	F-11
IC501	C-24	Q552	G-23	Q814	F-12
IC502	D-22	Q561	J-26	Q815	F-12
IC503	D-19	Q562	J-26	Q816	I-13
IC504	F-21				
IC505	F-19				

Note on Mounting Diagram:  
 • ○ : parts extracted from the component side.

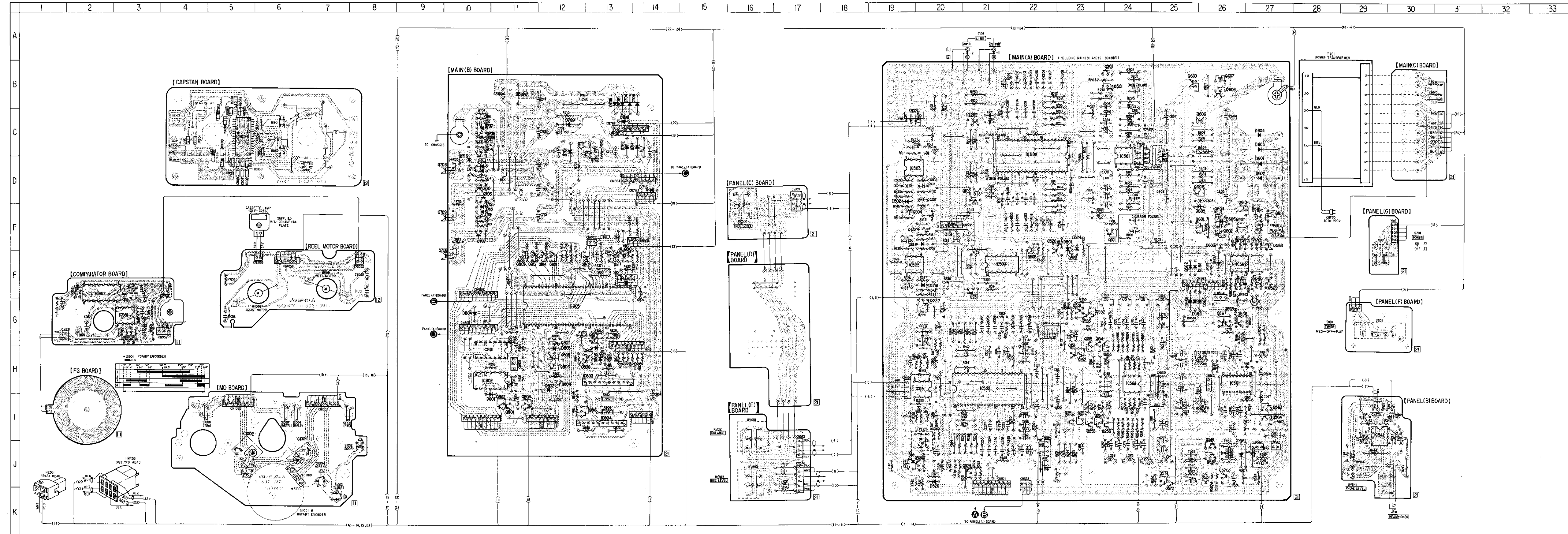

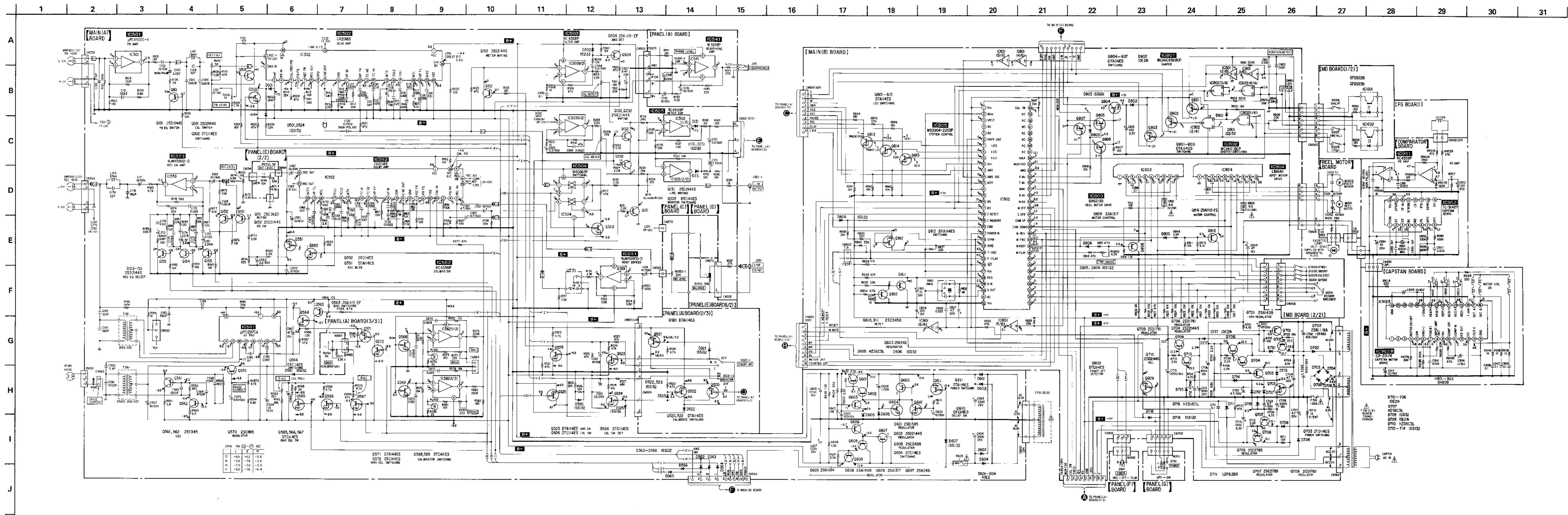

**Note on Schematic Diagram:**

- All capacitors are in  $\mu\text{F}$  unless otherwise noted. pF:  $\mu\text{F}$  50V or less are not indicated except for electrolytics and tantalums.
- All resistors are in  $\Omega$  and  $\frac{1}{2}\text{W}$  or less unless otherwise specified.
- Components for right channel have same values as for left channel. Reference numbers are coded from 201 to 299.
- $\Delta$ : internal component.
- $\square$ : nonflammable resistor.
- $\text{---}/\text{---}$ : fusible resistor.

**Note: The components identified by mark  $\Delta$  or dotted line with mark  $\Delta$  are critical for safety. Replace only with part number specified.**

- B+:** B+ Line
- B-:** B- Line
- $\square$ : adjustment for repair
- Voltage and waveforms are dc with respect to ground under no-signal (detuned) conditions.
- no mark: STOP
- ( ): PLAY
- ( ): REC
- Voltages are taken with a VOM (Input impedance 10 M  $\Omega$ )
- Voltage variations may be noted due to normal production tolerances.
- Signal path.
- $\text{---}/\text{---}$ : PB
- $\text{---}/\text{---}$ : REC

Semiconductor Location

Ref. No.	Location
D141	E-6
D521	C-8
D522	B-8
D523	B-8
D901	E-1
D902	E-1
D903	B-5
D904	C-5
D905	B-4
D906	E-9
D907	D-6
D908	D-6
D909	E-8
D910	E-9
D911	E-8
D912	D-9
D913	D-9
D914	D-9
D915	D-8
IC901	D-3
IC902A	D-5
IC903	D-6
IC904	E-8
Q520	C-9
Q521	C-8
Q522	C-8
Q901	D-1
Q902	D-1
Q903	D-1
Q904	D-1
Q905	E-2
Q906	E-3
Q907	C-6
Q908	E-1
Q909	E-1
Q910	E-9
Q911	E-9
Q912	E-9
Q913	E-9
Q914	E-8
Q915	D-8
Q916	E-8
Q917	D-8
Q918	D-9
Q919	D-9
Q920	D-9
Q921	D-9
Q922	C-1
Q923	C-2

Note on Mounting Diagram:  
 ● — : parts extracted from the component side.

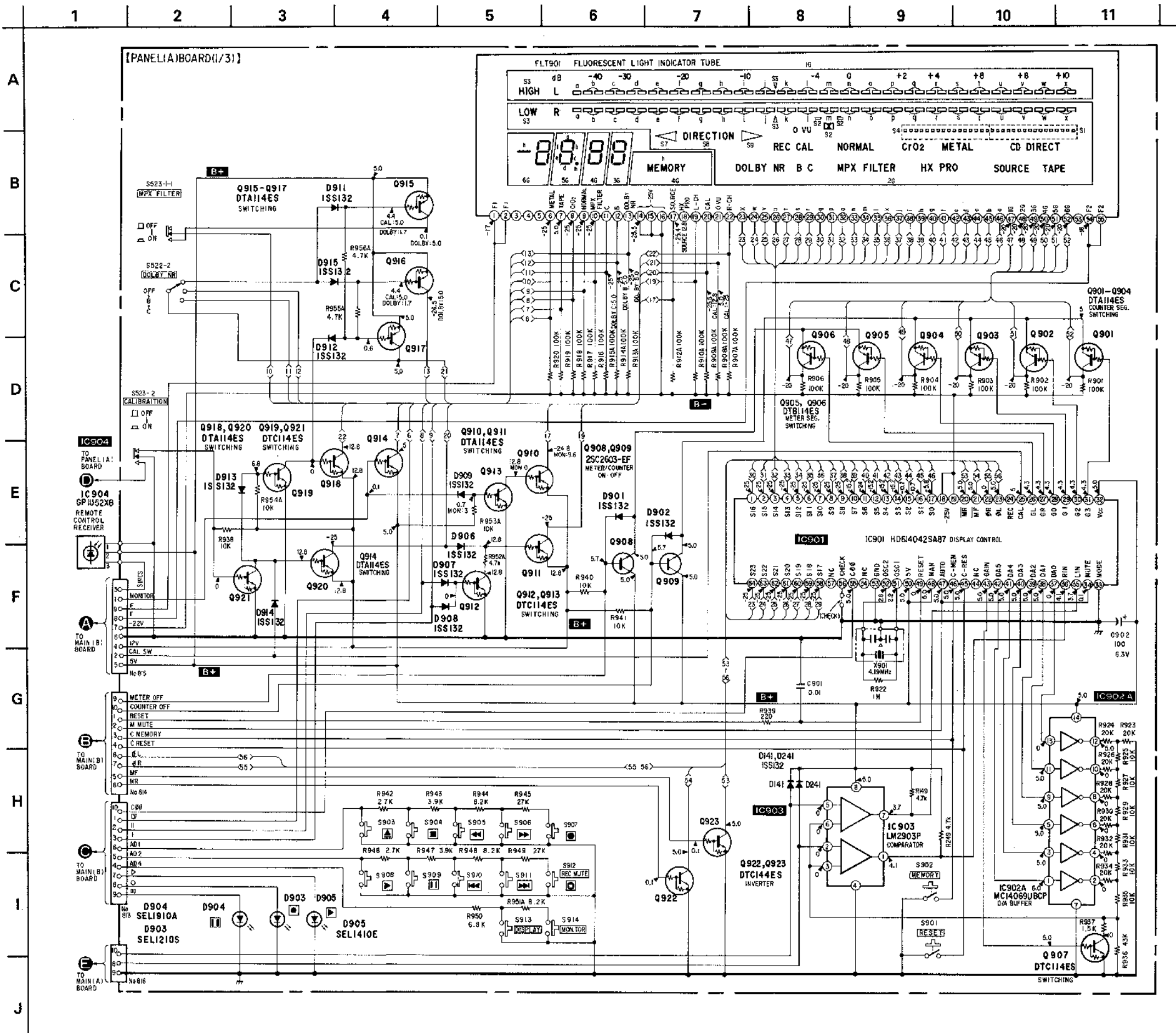
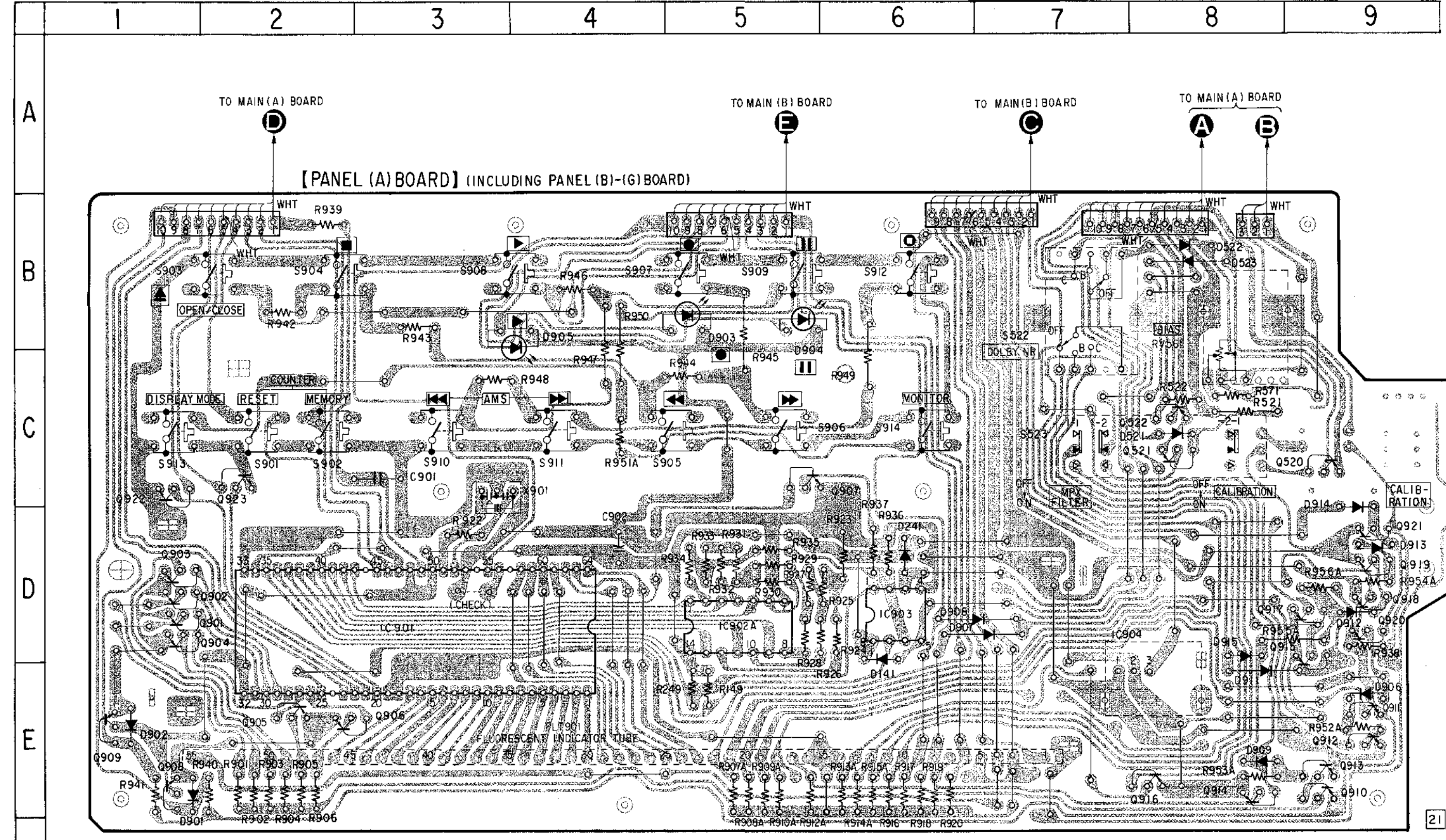

Note on Schematic Diagram:  
 • All capacitors are in  $\mu\text{F}$  unless otherwise noted.  $\text{pF}$ :  $\mu\text{F}$   
 50WV or less are not indicated except for electrolytics and tantalums.  
 • All resistors are in  $\Omega$  and  $\frac{1}{4}\text{W}$  or less unless otherwise specified.  
 •  $\Delta$ : internal component.  
 • B+: B+ Line  
 • B-: B- Line  
 •  $\square$ : adjustment for repair  
 • Voltages are taken with a VOM (input impedance 10 M  $\Omega$ )  
 Voltage variations may be noted due to normal production tolerances.

## SECTION 5 EXPLODED VIEWS

**NOTE:**

- The mechanical parts with no reference number in the exploded views are not supplied.
- The construction parts of an assembled part are indicated with a collation number in the remark column.
- Items marked "\*" are not stocked since they are seldom required for routine service. Some delay should be anticipated when ordering these items.

- Due to standardization, parts with part number suffix -XX and -X may be different from the parts specified in the components used on the set.
- Color Indication of Appearance Parts Example:  
(RED) ... KNOB, BALANCE (WHITE)  
↑ Cabinet's Color                      ↑ Parts' Color

The components identified by mark or dotted line with mark are critical for safety. Replace only with part number specified.

### 5-1. OVERALL SECTION

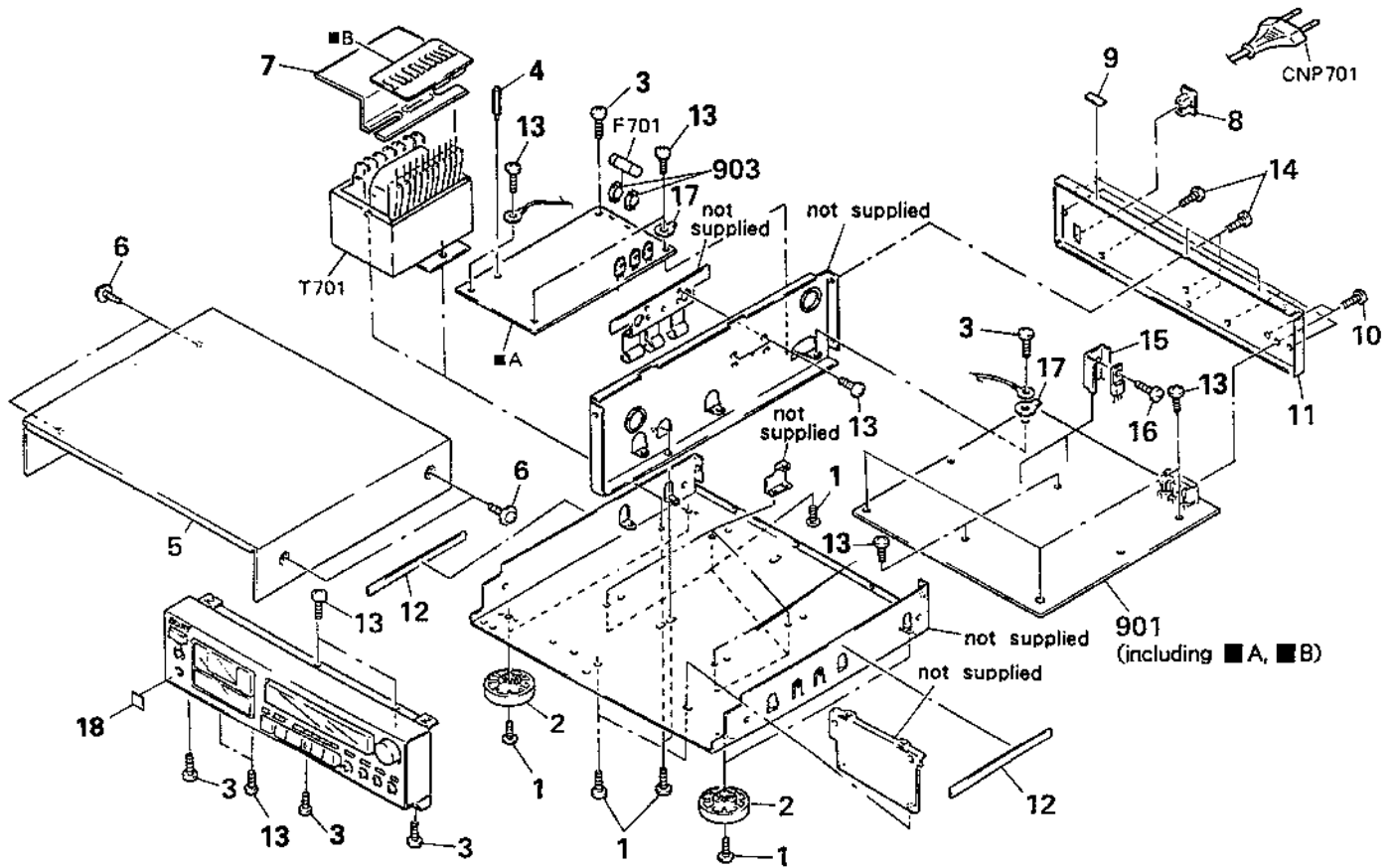

No.	Part No.	Description	Remarks	No.	Part No.	Description	Remarks
1	7-682-548-04	SCREW +BVT 3X8 (S)		12	*3-657-780-00	CUSHION	
2	X-3304-944-1	FOOT ASSY		13	7-682-547-04	SCREW +BVT 3X6 (S)	
3	3-703-685-21	SCREW (+BV 3X8)		14	7-682-548-09	SCREW +BVT 3X8 (S)	
4	*4-352-844-01	PIN, LEAD, COATING		15	*3-309-144-21	HEAT SINK	
5	4-925-039-61	CASE		16	7-682-547-04	SCREW +BVT 3X6 (S)	
6	3-704-366-01	SCREW (CASE) (M3X8)		17	4-870-539-00	PLATE, GROUND	
7	*3-356-961-02	COVER (TRANSFORMER)		18	*3-703-710-41	STICKER, SONY SYMBOL (12)	
8	*3-703-244-00	BUSHING (2104), CORD		901	*A-2006-268-A	MOUNTED PCB, MAIN	
9	3-831-441-XX	CUSHION (B), CABINET		903	1-533-213-31	HOLDER, FUSE	
10	7-621-849-00	SCREW, TAPPING		CNP701	1-555-795-00	CORD, POWER, EULO PLUG	
11	*3-350-460-41	(AEP).....PANEL, BACK		F701	△1-532-285-00	FUSE, TIME-LAG	
	*3-350-460-51	(West Germany)...PANEL, BACK		T701	△1-449-986-11	TRANSFORMER, POWER	

5-2. PANEL SECTION

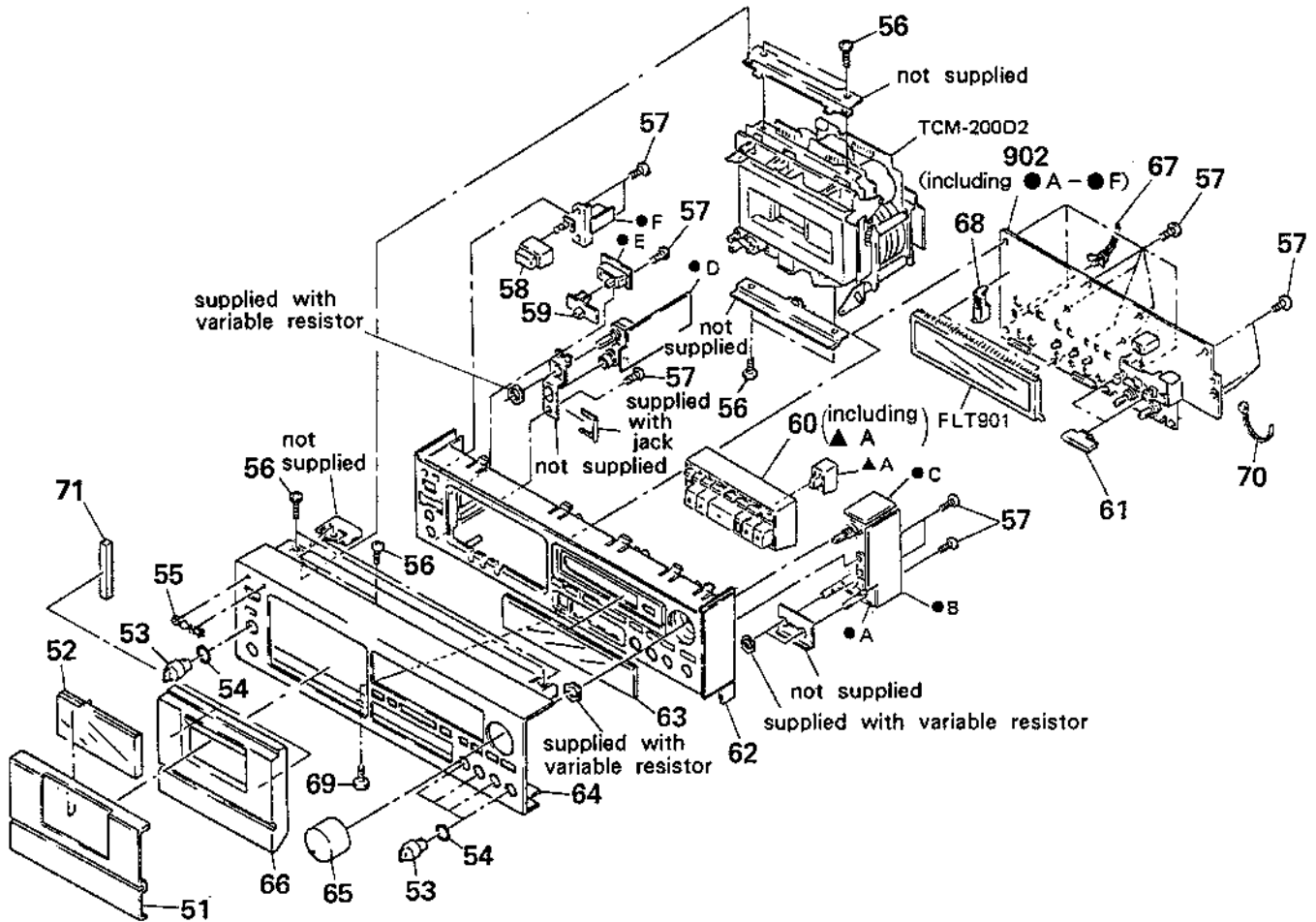

No.	Part No.	Description	Remarks	No.	Part No.	Description	Remarks
51	3-356-907-21	PLATE (C), ORNAMENTAL		62	3-356-915-01	PANEL (BASE)	
52	3-356-902-01	WINDOW (C)		63	3-356-909-11	WINDOW (METER)	
53	3-350-495-01	KNOB (VOL)		64	3-356-914-41	PANEL, FRONT	
54	3-356-957-01	SPRING		65	X-3304-961-1	KNOB (VOL.) ASSY (REC LEVEL)	
55	4-908-848-01	EMBLEM, SONY		66	3-356-908-01	LID, CASSETTE	
56	7-682-547-04	SCREW +BVTT 3X6 (S)		67	3-704-208-01	BAND, BINDING	
57	4-928-635-01	SCREW, +BV (2.6X8) TAPPING		68	*3-356-924-01	HOLDER (FL)	
58	3-354-912-01	KNOB, POWER		69	7-685-133-19	SCREW +BTP 2.6X6 TYPE2 N-S	
59	3-307-538-21	KNOB, SWITCH, TIMER		70	3-701-748-00	CLAMP	
60	X-3304-963-1	BUTTON ASSY		71	9-911-840-XX	CUSHION	
61	3-350-496-01	BUTTON		902	*A-2006-269-A	MOUNTED PCB, PANEL	

5-3. MECHANISM SECTION (1)  
(TCM-200D3)

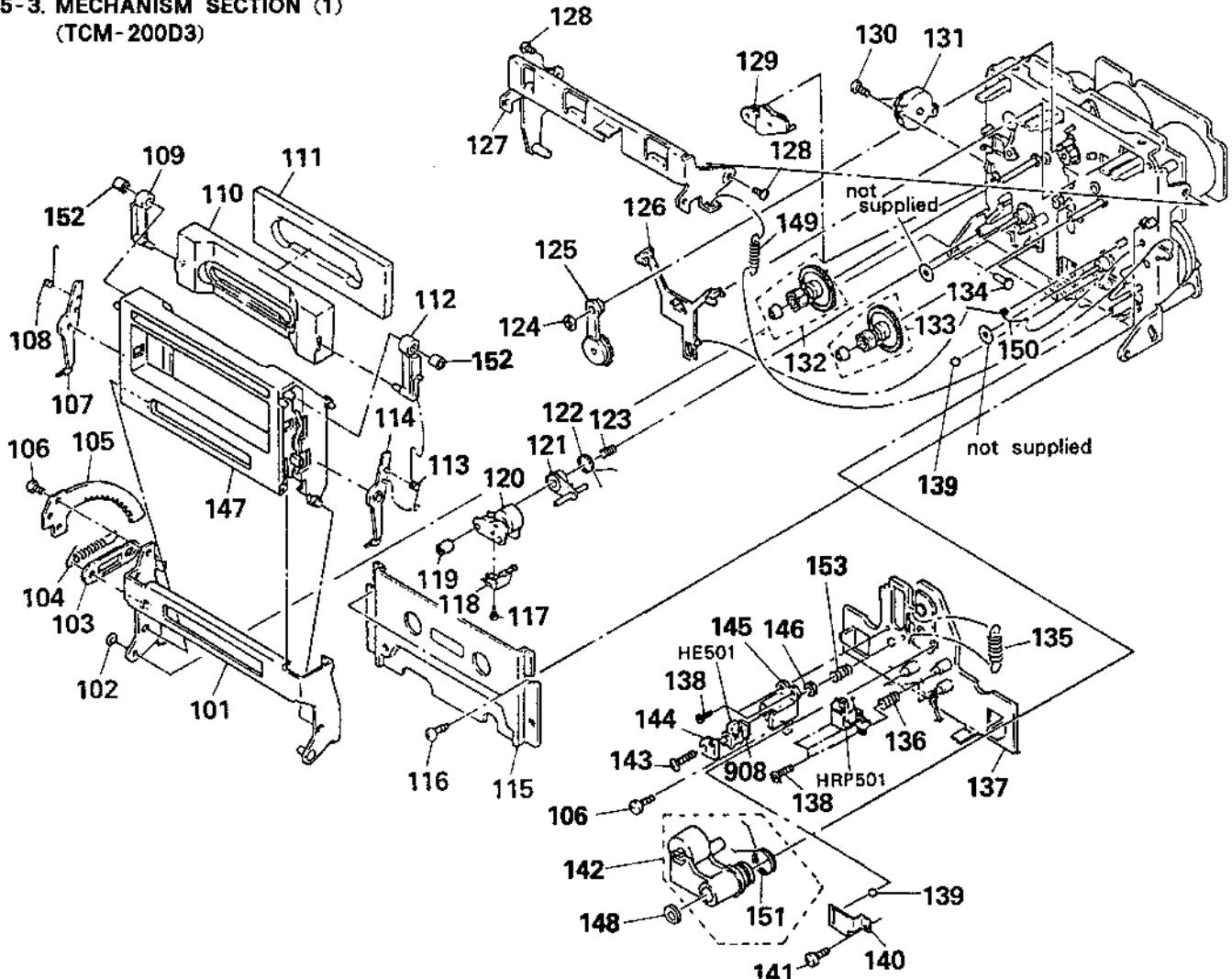

No.	Part No.	Description	Remarks	No.	Part No.	Description	Remarks
101	X-3356-612-1	HOLDER (B) ASSY, CASSETTE		130	7-685-851-09	SCREW +BVTT 2X4 (S)	
102	3-558-708-21	WASHER, STOPPER		131	3-712-786-41	DAMPER, OIL	
103	*3-356-717-01	LEVER (JOINT)		132	X-3356-629-1	GEAR (S) ASSY	
104	3-356-626-01	SPRING, TENSION		133	X-3356-627-1	GEAR (T) ASSY	
105	3-356-708-01	GEAR (SOFT EJECT)		134	3-356-710-01	SHAFT (LEFT) (CASSETTE HOLDER)	
106	7-621-775-10	SCREW +B 2.6X4		135	3-356-658-01	SPRING (LIMITER H), TENSION	
107	3-356-932-01	LEVER (LA)		136	3-356-659-01	SPRING (RPH), COMPRESSION	
108	3-356-927-01	SPRING (LEFT), TORSION		137	*X-3356-617-1	SLIDER (HEAD PC BOARD) ASSY	
109	3-356-933-01	LEVER (LB)		138	7-621-255-20	SCREW +P 2X4	
110	3-356-928-01	PLATE (A), ORNAMENTAL		139	7-671-154-01	STAINLESS BALL	
111	*3-356-731-01	ABSORBENT, VIBRATION		140	3-356-656-01	SPRING (HEAD PC BOARD), LEAF	
112	3-356-931-01	LEVER (RB)		141	7-685-870-01	SCREW +BVTT 3X5 (S)	
113	3-356-926-01	SPRING (RIGHT), TORSION		142	X-3356-620-1	LEVER (PINCH LEVER T) ASSY	
114	3-356-930-01	LEVER (RA)		143	7-621-772-70	SCREW +B 2X14	
115	X-3356-613-1	PLATE ASSY, ORNAMENTAL		144	3-318-433-01	SPRING	
116	7-685-133-19	SCREW +BTP 2.6X6 TYPE2 N-S		145	*3-576-977-00	BRACKET, E. HEAD	
117	7-628-253-00	SCREW +PS 2X4		146	7-622-205-05	NUT M2 TYPE2	
118	3-564-138-00	GUIDE (S), TAPE		147	X-3356-611-1	HOLDER (A) ASSY, CASSETTE	
119	3-356-652-01	NUT (PINCH LEVER S)		148	3-669-596-00	WASHER (2.3), STOPPER	
120	X-3356-621-1	LEVER (PINCH LEVER S) ASSY		149	3-356-624-01	SPRING, TENSION	
121	3-356-660-01	LEVER (PS)		150	3-356-619-01	SPRING (B), TORSION	
122	3-356-661-01	SPRING (PINCH LEVER S), TORSION		151	3-356-672-01	SPRING (PINCH LEVER T), TORSION	
123	3-356-657-01	SPRING (PS), COMPRESSION		152	3-356-946-01	BUSHING	
124	3-669-465-00	WASHER (1.5), STOPPER		153	3-564-121-00	SPRING, COMPRESSION	
125	X-3356-641-1	LEVER (FR2) ASSY		908	*1-608-268-00	PC BOARD, ERASE HEAD	
126	3-356-614-01	SLIDER (BRAKE)		HE501	1-543-358-11	HEAD, MAGNETIC (ERASE)	
127	*X-3356-608-1	LEVER (LIFTER) ASSY		HRP501	1-543-742-11	HEAD, MAGNETIC (REC/PB)	
128	3-356-601-01	SCREW, STEP					
129	X-3356-623-1	LEVER (BT) ASSY					

5-4. MECHANISM SECTION (2)  
(TCM-200D3)

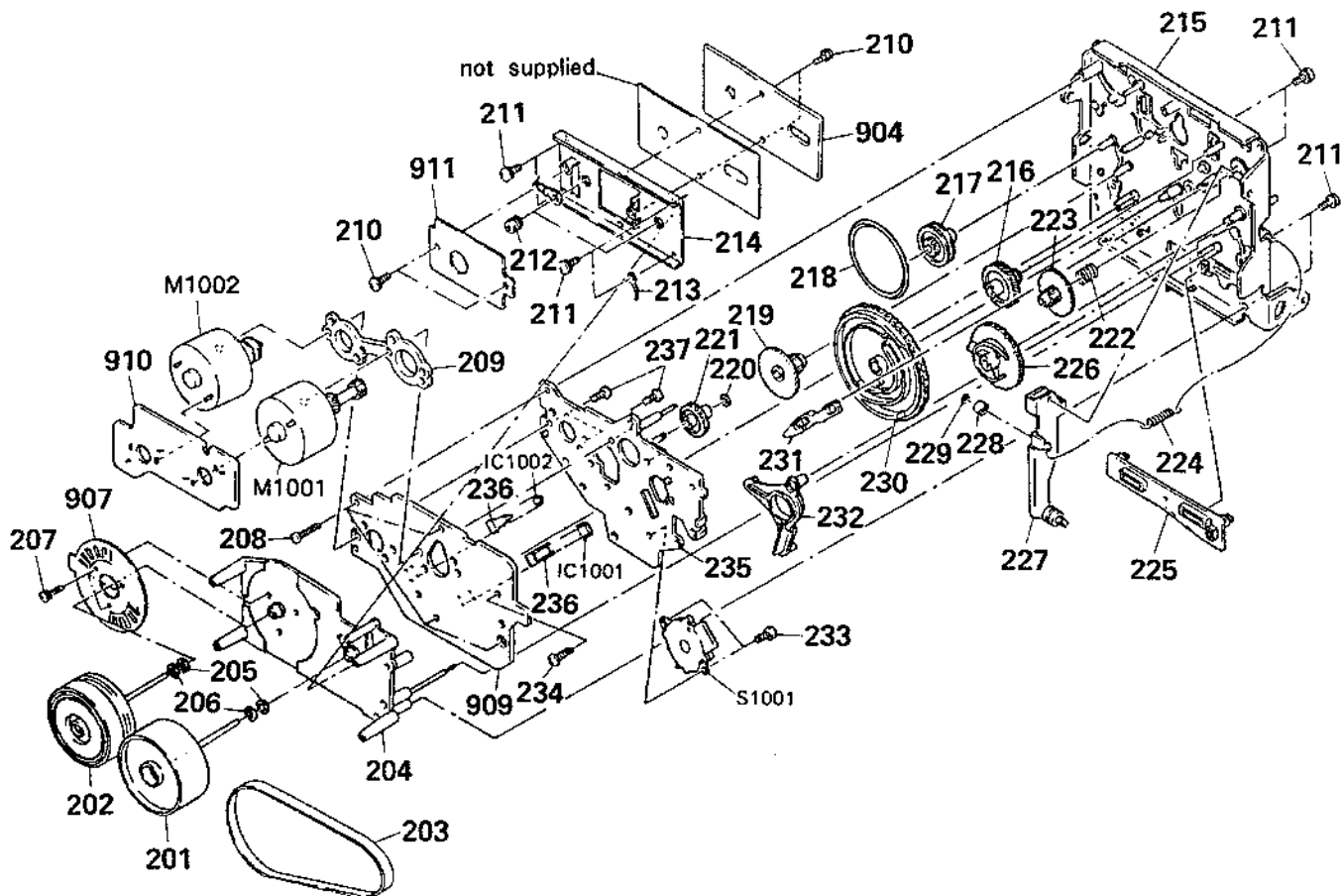

No.	Part No.	Description	Remarks	No.	Part No.	Description	Remarks
201	X-3356-626-1	FLYWHEEL (S) ASSY		224	3-356-625-01	SPRING, TENSION	
202	X-3356-619-1	FLYWHEEL (DT) ASSY		225	3-356-653-01	SLIDER (PAUSE)	
203	3-564-088-00	BELT (2), CAPSTAN		226	3-356-616-01	GEAR (LOADING CAM)	
204	*X-3356-614-1	DECK (D1) ASSY		227	*X-3356-606-1	LEVER (LOADING) ASSY	
205	3-356-705-31	WASHER (CAPSTAN)		228	3-356-630-01	ROLLER (LOADING)	
206	3-356-705-21	WASHER (CAPSTAN)		229	3-558-708-11	WASHER, STOPPER	
207	7-628-254-10	SCREW +PS 2.6X6		230	3-356-654-01	GEAR (MODE CAM C)	
208	3-355-801-01	SCREW (BTP 2X18)		231	3-356-617-01	LEVER (SELECTION)	
209	*3-356-628-01	SPACER (MOTOR)		232	3-356-613-01	LEVER (MODE)	
210	7-685-870-01	SCREW +BVTI 3X5 (S)		233	7-621-772-20	SCREW +B 2X5	
211	7-682-648-09	SCREW +PS 3X8		234	3-356-707-01	SCREW (+PTPWH 2X25)	
212	3-489-073-00	SCREW, THRUST		235	*X-3356-616-1	BRACKET (MOTOR D) ASSY	
213	*3-701-822-00	HOLDER, WIRE		236	3-356-631-01	HOLDER (SENSOR)	
214	*X-3356-615-1	BRACKET (THRUST RETAINER D) ASSY		237	7-621-773-95	SCREW +B 2.6X6	
215	X-3356-622-1	CHASSIS (C) ASSY, MECHANICAL		904	A-2006-154-A	MOUNTED PCB, CAPSTAN C.O.C	
216	3-356-703-01	GEAR (COMMUNICATION C)		907	1-632-779-11	PC BOARD, FG	
217	3-356-607-01	PULLEY (MODE)		909	*1-632-740-11	PC BOARD, MD	
218	3-356-603-01	BELT (MODE)		910	*1-632-741-11	PC BOARD, REAL MOTOR	
219	3-356-606-01	GEAR (MODE)		911	*1-632-746-11	PC BOARD, COMPARATOR	
220	3-669-465-00	WASHER (1.5), STOPPER		M1001	X-3356-638-1	MOTOR (REEL R) ASSY	
221	3-356-702-01	GEAR (COMMUNICATION B)		M1002	X-3356-604-1	MOTOR (ASSIST) ASSY	
222	3-356-605-01	SPRING, COMPRESSION		S1001	1-466-238-11	ENCODER, ROTARY	
223	3-356-609-01	GEAR (LOADING)					

## SECTION 6 ELECTRICAL PARTS LIST

**NOTE:**

- Due to standardization, replacements in the parts list may be different from the parts specified in the diagrams or the components used on the set.
- Items marked "★" are not stocked since they are seldom required for routine service. Some delay should be anticipated when ordering these items.
- If there are two or more same circuits in a set such as a stereophonic machine, only typical circuit parts may be indicated and capacitors and resistors in other same circuits may be omitted.

**CAPACITORS:**  
MF:  $\mu$ F, PF:  $\mu$ μF.

**RESISTORS**  
● All resistors are in ohms.  
● F: nonflammable

**COILS**  
● MMH: mH, UH:  $\mu$ H

**SEMICONDUCTORS**  
In each case, U:  $\mu$ , for example:  
UA...:  $\mu$ A..., UPA...:  $\mu$ PA...,  
UPC...:  $\mu$ PC, UPD...:  $\mu$ PD...



The components identified by mark  $\Delta$  or dotted line with mark  $\Delta$  are Critical for safety. Replace only with part number specified.

Ref.No.	Part No.	Description					Ref.No.	Part No.	Description				
901	*A-2006-268-A	MOUNTED PCB, MAIN					C164	1-124-791-11	ELECT	1MF	20%	50V	
902	*A-2006-269-A	MOUNTED PCB, PANEL					C165	1-130-480-00	MYLAR	0.0056MF	5%	50V	
903	1-533-213-31	HOLDER, FUSE					C166	1-136-153-00	FILM	0.01MF	5%	50V	
904	A-2006-154-A	MOUNTED PCB, CAPSTAN C.O.C					C167	1-126-059-11	ELECT	10MF	20%	50V	
907	1-632-779-11	PC BOARD, FG					C168	1-130-474-00	MYLAR	0.0018MF	5%	50V	
908	*1-608-268-00	PC BOARD, ERASE HEAD					C169	1-126-059-11	ELECT	10MF	20%	50V	
909	*1-632-740-11	PC BOARD, MD					C170	1-136-163-00	FILM	0.068MF	5%	50V	
910	*1-632-741-11	PC BOARD, REAL MOTOR					C171	1-126-059-11	ELECT	10MF	20%	50V	
911	*1-632-746-11	PC BOARD, COMPARATOR					C172	1-136-157-00	FILM	0.022MF	5%	50V	
C100	1-110-340-11	MYLAR	270PF	5%	50V	C173	1-136-157-00	FILM	0.022MF	5%	50V		
C101	1-130-973-00	FILM	0.022MF	5%	100V	C174	1-136-156-00	FILM	0.018MF	5%	50V		
C102	1-124-657-00	ELECT(NONPOLAR)	10MF	20%	50V	C175	1-130-481-00	MYLAR	0.0068MF	5%	50V		
C103	1-136-158-00	FILM	0.027MF	5%	50V	C176	1-136-154-00	FILM	0.012MF	5%	50V		
C104	1-102-966-00	CERAMIC	43PF	5%	50V	C178	1-110-338-00	MYLAR	180PF	5%	50V		
C105	1-130-474-00	MYLAR	0.0018MF	5%	50V	C179	1-136-935-11	FILM	22PF	5%	630V		
C106	1-130-474-00	MYLAR	0.0018MF	5%	50V	C180	1-123-369-00	ELECT	4.7MF	20%	50V		
C107	1-130-475-00	MYLAR	0.0022MF	5%	50V	C191	1-136-803-11	FILM	560PF	5%	630V		
C108	1-130-475-00	MYLAR	0.0022MF	5%	50V	C192	1-136-433-11	FILM	100PF	5%	630V		
C109	1-130-478-00	MYLAR	0.0039MF	5%	50V	C193	1-130-468-00	MYLAR	560PF	5%	50V		
C110	1-136-173-00	FILM	0.47MF	5%	50V	C194	1-136-165-00	FILM	0.1MF	5%	50V		
C111	1-136-167-00	FILM	0.15MF	5%	50V	C195	1-136-165-00	FILM	0.1MF	5%	50V		
C112	1-136-155-00	FILM	0.015MF	5%	50V	C196	1-136-157-00	FILM	0.022MF	5%	50V		
C113	1-124-791-11	ELECT	1MF	20%	50V	C200	1-110-340-11	MYLAR	270PF	5%	50V		
C114	1-136-169-00	FILM	0.22MF	5%	50V	C201	1-130-973-00	FILM	0.022MF	5%	100V		
C115	1-136-163-00	FILM	0.068MF	5%	50V	C202	1-124-657-00	ELECT(NONPOLAR)	10MF	20%	50V		
C116	1-136-162-00	FILM	0.056MF	5%	50V	C203	1-136-158-00	FILM	0.027MF	5%	50V		
C117	1-124-791-11	ELECT	1MF	20%	50V	C204	1-102-966-00	CERAMIC	43PF	5%	50V		
C118	1-130-480-00	MYLAR	0.0056MF	5%	50V	C205	1-130-474-00	MYLAR	0.0018MF	5%	50V		
C119	1-136-153-00	FILM	0.01MF	5%	50V	C206	1-130-474-00	MYLAR	0.0018MF	5%	50V		
C120	1-124-657-00	ELECT(NONPOLAR)	10MF	20%	50V	C207	1-130-475-00	MYLAR	0.0022MF	5%	50V		
C131	1-123-382-00	ELECT	3.3MF	20%	50V	C208	1-130-475-00	MYLAR	0.0022MF	5%	50V		
C141	1-126-059-11	ELECT	10MF	20%	50V	C209	1-130-478-00	MYLAR	0.0039MF	5%	50V		
C151	1-123-369-00	ELECT	4.7MF	20%	50V	C210	1-136-173-00	FILM	0.47MF	5%	50V		
C152	1-123-369-00	ELECT	4.7MF	20%	50V	C211	1-136-167-00	FILM	0.15MF	5%	50V		
C153	1-126-059-11	ELECT	10MF	20%	50V	C212	1-136-155-00	FILM	0.015MF	5%	50V		
C154	1-130-475-00	MYLAR	0.0022MF	5%	50V	C213	1-124-791-11	ELECT	1MF	20%	50V		
C155	1-130-475-00	MYLAR	0.0022MF	5%	50V	C214	1-136-169-00	FILM	0.22MF	5%	50V		
C156	1-130-478-00	MYLAR	0.0039MF	5%	50V	C215	1-136-163-00	FILM	0.068MF	5%	50V		
C157	1-136-173-00	FILM	0.47MF	5%	50V	C216	1-136-162-00	FILM	0.056MF	5%	50V		
C158	1-136-167-00	FILM	0.15MF	5%	50V	C217	1-124-791-11	ELECT	1MF	20%	50V		
C159	1-136-155-00	FILM	0.015MF	5%	50V	C218	1-130-480-00	MYLAR	0.0056MF	5%	50V		
C160	1-124-791-11	ELECT	1MF	20%	50V	C219	1-136-153-00	FILM	0.01MF	5%	50V		
C161	1-136-169-00	FILM	0.22MF	5%	50V	C220	1-124-657-00	ELECT(NONPOLAR)	10MF	20%	50V		
C162	1-136-163-00	FILM	0.068MF	5%	50V	C231	1-123-382-00	ELECT	3.3MF	20%	50V		
C163	1-136-162-00	FILM	0.056MF	5%	50V	C241	1-126-059-11	ELECT	10MF	20%	50V		



Ref.No.	Part No.	Description				Ref.No.	Part No.	Description			
C251	1-123-369-00	ELECT	4.7MF	20%	50V	C571	1-130-474-00	MYLAR	0.0018MF	5%	50V
C252	1-123-369-00	ELECT	4.7MF	20%	50V	C572	1-136-157-00	FILM	0.022MF	5%	50V
C253	1-126-059-11	ELECT	10MF	20%	50V	C573	1-136-157-00	FILM	0.022MF	5%	50V
C254	1-130-475-00	MYLAR	0.0022MF	5%	50V	C574	1-124-902-00	ELECT	0.47MF	20%	50V
C255	1-130-475-00	MYLAR	0.0022MF	5%	50V	C603	1-124-636-00	ELECT	3300MF	20%	25V
C256	1-130-478-00	MYLAR	0.0039MF	5%	50V	C604	1-124-636-00	ELECT	3300MF	20%	25V
C257	1-136-173-00	FILM	0.47MF	5%	50V	C605	1-126-101-11	ELECT	100MF	20%	10V
C258	1-136-167-00	FILM	0.15MF	5%	50V	C606	1-124-602-00	ELECT	2200MF	20%	35V
C259	1-136-155-00	FILM	0.015MF	5%	50V	C607	1-124-602-00	ELECT	2200MF	20%	35V
C260	1-124-791-11	ELECT	1MF	20%	50V	C608	1-124-791-11	ELECT	1MF	20%	50V
C261	1-136-169-00	FILM	0.22MF	5%	50V	C609	1-123-875-11	ELECT	10MF	20%	50V
C262	1-136-163-00	FILM	0.068MF	5%	50V	C701	1-124-910-11	ELECT	47MF	20%	50V
C263	1-136-162-00	FILM	0.056MF	5%	50V	C702	1-124-122-11	ELECT	100MF	20%	50V
C264	1-124-791-11	ELECT	1MF	20%	50V	C703	1-126-105-11	ELECT	1000MF	20%	35V
C265	1-130-480-00	MYLAR	0.0056MF	5%	50V	C704	1-124-927-11	ELECT	4.7MF	20%	50V
C266	1-136-153-00	FILM	0.01MF	5%	50V	C705	1-124-927-11	ELECT	4.7MF	20%	50V
C267	1-126-059-11	ELECT	10MF	20%	50V	C706	1-124-473-11	ELECT	1000MF	20%	10V
C268	1-130-474-00	MYLAR	0.0018MF	5%	50V	C707	1-124-927-11	ELECT	4.7MF	20%	50V
C269	1-126-059-11	ELECT	10MF	20%	50V	C708	1-124-556-11	ELECT	2200MF	20%	16V
C270	1-136-163-00	FILM	0.068MF	5%	50V	C709	1-124-927-11	ELECT	4.7MF	20%	50V
C271	1-126-059-11	ELECT	10MF	20%	50V	C710	1-124-471-00	ELECT	1000MF	20%	6.3V
C272	1-136-157-00	FILM	0.022MF	5%	50V	C711	1-136-165-00	FILM	0.1MF	5%	50V
C273	1-136-157-00	FILM	0.022MF	5%	50V	C712	1-124-927-11	ELECT	4.7MF	20%	50V
C274	1-136-156-00	FILM	0.018MF	5%	50V	C713	1-124-556-11	ELECT	2200MF	20%	16V
C275	1-130-481-00	MYLAR	0.0068MF	5%	50V	C714	1-124-618-11	ELECT	2200MF	20%	35V
C276	1-136-154-00	FILM	0.012MF	5%	50V	C801	1-162-294-31	CERAMIC	0.001MF	10%	50V
C278	1-110-338-00	MYLAR	180PF	5%	50V	C802	1-162-294-31	CERAMIC	0.001MF	10%	50V
C279	1-136-935-11	FILM	22PF	5%	630V	C803	1-124-472-11	ELECT	470MF	20%	6.3V
C280	1-123-369-00	ELECT	4.7MF	20%	50V	C804	1-124-477-11	ELECT	47MF	20%	16V
C291	1-136-803-11	FILM	560PF	5%	630V	C805	1-164-159-11	CERAMIC	0.1MF		50V
C292	1-136-433-11	FILM	100PF	5%	630V	C806	1-164-159-11	CERAMIC	0.1MF		50V
C293	1-130-468-00	MYLAR	560PF	5%	50V	C807	1-124-927-11	ELECT	4.7MF	20%	50V
C294	1-136-165-00	FILM	0.1MF	5%	50V	C808	1-161-494-00	CERAMIC	0.022MF		25V
C295	1-136-165-00	FILM	0.1MF	5%	50V	C809	1-124-443-00	ELECT	100MF	20%	10V
C296	1-136-157-00	FILM	0.022MF	5%	50V	C810	1-123-875-11	ELECT	10MF	20%	50V
C503	1-136-165-00	FILM	0.1MF	5%	50V	C901	1-161-379-00	CERAMIC	0.01MF	30%	16V
C504	1-124-925-11	ELECT	2.2MF	20%	50V	C902	1-126-177-11	ELECT	100MF	20%	6.3V
C505	1-124-925-11	ELECT	2.2MF	20%	50V	C905	1-124-779-00	ELECT CHIP	10MF	20%	16V
C506	1-130-475-00	MYLAR	0.0022MF	5%	50V	C906	1-135-091-00	TANTAL. CHIP	1MF	10%	16V
C507	1-124-902-00	ELECT	0.47MF	20%	50V	C907	1-163-077-00	CERAMIC CHIP	0.1MF		50V
C521	1-123-875-11	ELECT	10MF	20%	50V	C908	1-163-077-00	CERAMIC CHIP	0.1MF		50V
C522	1-126-233-11	ELECT	22MF	20%	25V	C909	1-163-077-00	CERAMIC CHIP	0.1MF		50V
C541	1-126-059-11	ELECT	10MF	20%	50V	C910	1-163-205-00	CERAMIC CHIP	0.001MF	10%	50V
C542	1-126-059-11	ELECT	10MF	20%	50V	C911	1-124-779-00	ELECT CHIP	10MF	20%	16V
C551	1-124-915-11	ELECT	10MF	20%	63V	C951	1-136-157-00	FILM	0.022MF	5%	50V
C552	1-124-915-11	ELECT	10MF	20%	63V	C952	1-124-282-00	ELECT(NONPOLAR)	22MF	20%	25V
C553	1-124-925-11	ELECT	2.2MF	20%	50V	C953	1-124-478-11	ELECT	100MF	20%	25V
C561	1-136-559-11	FILM	0.0047MF	5%	630V	C954	1-124-477-11	ELECT	47MF	20%	25V
C562	1-107-045-00	MICA	3.9PF	0.5PF	500V	C955	1-162-203-31	CERAMIC	15PF	5%	50V
C563	1-123-875-11	ELECT	10MF	20%	50V	C956	1-162-203-31	CERAMIC	15PF	5%	50V
C564	1-136-233-11	FILM	0.0047MF	5%	100V	C957	1-136-159-00	FILM	0.033MF	5%	50V
C565	1-136-228-11	FILM	0.0012MF	5%	100V	C1051	1-123-875-11	ELECT	10MF	20%	50V
C566	1-136-228-11	FILM	0.0012MF	5%	100V	C1052	1-123-875-11	ELECT	10MF	20%	50V
C567	1-124-477-11	ELECT	47MF	20%	16V	C1053	1-164-159-11	CERAMIC	0.1MF		50V
C568	1-124-915-11	ELECT	10MF	20%	63V	CN501	*1-560-062-00	PIN, CONNECTOR	4P		
C569	1-124-902-00	ELECT	0.47MF	20%	50V	CN502	*1-564-508-11	PLUG, CONNECTOR	5P		
C570	1-130-474-00	MYLAR	0.0018MF	5%	50V	CN521	*1-564-666-11	PIN, CONNECTOR	10P		

Ref.No.	Part No.	Description	Ref.No.	Part No.	Description
CN522	*1-564-337-00	PIN, CONNECTOR 3P	D607	8-719-107-94	DIODE 1SS202-1
CN552	*1-564-507-11	PLUG, CONNECTOR 4P	D701	8-719-200-77	DIODE 10E2N
CN553	*1-564-507-11	PLUG, CONNECTOR 4P	D702	8-719-200-77	DIODE 10E2N
CN554	*1-564-509-11	PLUG, CONNECTOR 6P	D703	8-719-200-77	DIODE 10E2N
CN555	*1-560-062-00	PIN, CONNECTOR 4P	D704	8-719-200-77	DIODE 10E2N
CN561	*1-560-061-00	PIN, CONNECTOR 3P	D705	8-719-200-77	DIODE 10E2N
CN562	*1-564-506-11	PLUG, CONNECTOR 3P	D706	8-719-200-77	DIODE 10E2N
CN563	*1-564-666-11	PIN, CONNECTOR 10P	D707	8-719-933-41	DIODE HZS6C3L
CN564	*1-564-506-11	PLUG, CONNECTOR 3P	D708	8-719-107-94	DIODE 1SS202-1
CN565	*1-564-505-11	PLUG, CONNECTOR 2P	D709	8-719-200-77	DIODE 10E2N
CN570	*1-564-520-11	PLUG, CONNECTOR 5P	D710	8-719-933-41	DIODE HZS6C3L
CN572	*1-564-519-11	PLUG, CONNECTOR 4P	D711	8-719-015-02	DIODE UZP-8.2BB
CN573	*1-564-519-11	PLUG, CONNECTOR 4P	D712	8-719-107-94	DIODE 1SS202-1
CN574	*1-564-521-11	PLUG, CONNECTOR 6P	D713	8-719-107-94	DIODE 1SS202-1
CN601	*1-560-061-00	PIN, CONNECTOR 3P	D714	8-719-107-94	DIODE 1SS202-1
CN701	*1-564-511-11	PLUG, CONNECTOR 8P	D715	8-719-001-79	DIODE UZL-12H1
CN702	*1-564-339-00	PIN, CONNECTOR 5P	D716	8-719-107-94	DIODE 1SS202-1
CN801	*1-564-506-11	PLUG, CONNECTOR 3P	D717	8-719-200-77	DIODE 10E2N
CN802	*1-564-505-11	PLUG, CONNECTOR 2P	D801	8-719-107-94	DIODE 1SS202-1
CN803	*1-564-337-00	PIN, CONNECTOR 3P	D802	8-719-200-77	DIODE 10E2N
CN804	*1-506-503-11	PIN, CONNECTOR 9P	D803	8-719-107-94	DIODE 1SS202-1
CN805	*1-564-666-11	PIN, CONNECTOR 10P	D804	8-719-107-94	DIODE 1SS202-1
CN806	*1-564-666-11	PIN, CONNECTOR 10P	D805	8-719-107-94	DIODE 1SS202-1
CN951	*1-564-718-11	PIN, CONNECTOR (SMALL TYPE) 2P	D806	8-719-107-94	DIODE 1SS202-1
CN952	*1-564-518-11	PLUG, CONNECTOR 3P	D901	8-719-107-94	DIODE 1SS202-1
CN1001	1-506-615-11	PIN, CONNECTOR 9P	D902	8-719-107-94	DIODE 1SS202-1
CN1002	1-564-501-11	PIN, CONNECTOR 8P	D903	8-719-302-46	LED SEL1210S-C
CN1051	*1-564-499-11	PIN, CONNECTOR 6P	D904	8-719-302-79	LED SEL1910A-C
CN1052	*1-564-718-11	PIN, CONNECTOR (SMALL TYPE) 2P	D905	8-719-302-45	LED SEL1210S
CN1053	*1-564-718-11	PIN, CONNECTOR (SMALL TYPE) 2P	D906	8-719-107-94	DIODE 1SS202-1
CNP701	1-555-795-00	CORD, POWER, EULO PLUG	D907	8-719-107-94	DIODE 1SS202-1
D131	8-719-107-94	DIODE 1SS202-1	D908	8-719-107-94	DIODE 1SS202-1
D141	8-719-107-94	DIODE 1SS202-1	D909	8-719-107-94	DIODE 1SS202-1
D231	8-719-107-94	DIODE 1SS202-1	D911	8-719-107-94	DIODE 1SS202-1
D241	8-719-107-94	DIODE 1SS202-1	D912	8-719-107-94	DIODE 1SS202-1
D501	8-719-107-94	DIODE 1SS202-1	D913	8-719-107-94	DIODE 1SS202-1
D502	8-719-107-94	DIODE 1SS202-1	D914	8-719-107-94	DIODE 1SS202-1
D521	8-719-107-94	DIODE 1SS202-1	D915	8-719-107-94	DIODE 1SS202-1
D522	8-719-107-94	DIODE 1SS202-1	F701	△1-532-285-00	FUSE, TIME-LAG
D523	8-719-197-94	DIODE 1SS202-1	FLT901	1-519-560-11	INDICATOR TUBE, FLUORESCENT
D524	8-719-107-94	DIODE 1SS202-1	H901	8-719-403-79	OH009 HOLE ELEMENT
D525	8-719-107-94	DIODE 1SS202-1	H902	8-719-403-79	OH009 HOLE ELEMENT
D526	8-719-107-94	DIODE 1SS202-1	H903	8-719-403-79	OH009 HOLE ELEMENT
D561	8-719-107-94	DIODE 1SS202-1	HE501	1-543-358-11	HEAD, MAGNETIC (ERASE)
D562	8-719-107-94	DIODE 1SS202-1	HRP501	1-543-742-11	HEAD, MAGNETIC (REC/PB)
D563	8-719-107-94	DIODE 1SS202-1	IC501	8-759-111-44	IC UPC4570C-1
D564	8-719-107-94	DIODE 1SS202-1	IC502	8-752-018-80	IC CX20188
D565	8-719-107-94	DIODE 1SS202-1	IC503	8-759-945-58	IC RC4558P
D566	8-719-107-94	DIODE 1SS202-1	IC504	8-759-208-14	IC TC4066BPHB
D601	8-719-200-77	DIODE 10E2N	IC505	8-759-945-58	IC RC4558P
D602	8-719-200-77	DIODE 10E2N	IC541	8-759-634-51	IC M5218AP
D603	8-719-200-77	DIODE 10E2N	IC551	8-759-710-59	IC NJM4580D-D
D604	8-719-200-77	DIODE 10E2N	IC552	8-752-018-80	IC CX20188
D605	8-719-933-41	DIODE HZS6C3L	IC553	8-759-710-59	IC NJM4580D-D
D606	8-719-107-94	DIODE 1SS202-1			

Note: The components identified by mark  or dotted line with mark  are critical for safety. Replace only with part number specified.

Ref.No.	Part No.	Description
IC561	8-759-106-56	IC UPC1297CA
IC562	8-759-945-58	IC RC4558P
IC801	8-759-240-69	IC TC4069UBP
IC802	8-759-140-11	IC UPD4011BC
IC803	8-759-973-95	IC BA6219B
IC804	8-759-822-09	IC LB1641
IC805	8-759-634-78	IC M50964-222SP
IC901	8-759-302-98	IC HD614042SA87
IC902A	8-759-240-69	IC TC4069UBP
IC902B	8-752-017-40	IC CX20174
IC903	8-759-984-97	IC LM2903P
IC904	8-749-920-83	IC GP1U52XB
IC951	8-759-945-58	IC RC4558P
IC952	8-759-201-58	IC TC9142P
IC1001	8-749-920-97	PHOTO REFLECTOR GP2S22B
IC1002	8-749-920-97	PHOTO REFLECTOR GP2S22B
J541	1-507-796-71	JACK (HEADPHONES)
J551	*1-568-069-11	JACK, PIN 4P (LINE)
JR901	1-216-296-00	METAL GLAZE 0 5% 1/8W
JR902	1-216-296-00	METAL GLAZE 0 5% 1/8W
JR903	1-216-296-00	METAL GLAZE 0 5% 1/8W
JR904	1-216-296-00	METAL GLAZE 0 5% 1/8W
JR905	1-216-296-00	METAL GLAZE 0 5% 1/8W
L101	1-410-778-11	INDUCTOR 18MMH
L151	1-410-767-11	INDUCTOR 2.2MMH
L152	1-410-769-31	INDUCTOR 3.3MMH
L153	1-410-773-11	INDUCTOR 6.8MMH
L154	1-410-780-11	INDUCTOR 27MMH
L201	1-410-778-11	INDUCTOR 18MMH
L251	1-410-767-11	INDUCTOR 2.2MMH
L252	1-410-769-31	INDUCTOR 3.3MMH
L253	1-410-773-11	INDUCTOR 6.8MMH
L254	1-410-780-11	INDUCTOR 27MMH
LPF151	1-236-087-11	FILTER, LOW PASS
LPF251	1-236-087-11	FILTER, LOW PASS
M1001	X-3356-638-1	MOTOR (REEL R) ASSY
M1002	X-3356-604-1	MOTOR (ASSIST) ASSY
PL561	1-518-471-31	LAMP, PILOT
PL562	1-518-471-31	LAMP, PILOT
Q101	8-729-922-37	TRANSISTOR 2SD2144S
Q102	8-729-922-37	TRANSISTOR 2SD2144S
Q131	8-729-922-37	TRANSISTOR 2SD2144S
Q132	8-729-922-37	TRANSISTOR 2SD2144S
Q151	8-729-141-30	TRANSISTOR 2SC3623A-LK
Q152	8-729-922-37	TRANSISTOR 2SD2144S
Q153	8-729-922-37	TRANSISTOR 2SD2144S
Q154	8-729-922-37	TRANSISTOR 2SD2144S
Q155	8-729-922-37	TRANSISTOR 2SD2144S
Q201	8-729-922-37	TRANSISTOR 2SD2144S
Q202	8-729-922-37	TRANSISTOR 2SD2144S
Q231	8-729-922-37	TRANSISTOR 2SD2144S
Q232	8-729-922-37	TRANSISTOR 2SD2144S
Q251	8-729-141-30	TRANSISTOR 2SC3623A-LK
Q252	8-729-922-37	TRANSISTOR 2SD2144S
Q253	8-729-922-37	TRANSISTOR 2SD2144S
Q254	8-729-922-37	TRANSISTOR 2SD2144S
Q255	8-729-922-37	TRANSISTOR 2SD2144S



Ref.No.	Part No.	Description
Q501	8-729-922-37	TRANSISTOR 2SD2144S
Q502	8-729-900-80	TRANSISTOR DTC114ES
Q503	8-729-900-89	TRANSISTOR DTC144ES
Q504	8-729-119-76	TRANSISTOR 2SA1175-HFE
Q520	8-729-900-61	TRANSISTOR DTA114ES
Q521	8-729-900-61	TRANSISTOR DTA114ES
Q522	8-729-900-61	TRANSISTOR DTA114ES
Q523	8-729-900-80	TRANSISTOR DTC114ES
Q524	8-729-900-80	TRANSISTOR DTC114ES
Q525	8-729-900-61	TRANSISTOR DTA114ES
Q526	8-729-900-80	TRANSISTOR DTC114ES
Q551	8-729-900-61	TRANSISTOR DTA114ES
Q552	8-729-900-80	TRANSISTOR DTC114ES
Q561	8-729-194-57	TRANSISTOR 2SC945-P
Q562	8-729-194-57	TRANSISTOR 2SC945-P
Q563	8-729-119-76	TRANSISTOR 2SA1175-HFE
Q564	8-729-900-80	TRANSISTOR DTC114ES
Q565	8-729-900-80	TRANSISTOR DTC114ES
Q566	8-729-900-80	TRANSISTOR DTC114ES
Q567	8-729-900-80	TRANSISTOR DTC114ES
Q568	8-729-900-89	TRANSISTOR DTC144ES
Q569	8-729-900-89	TRANSISTOR DTC144ES
Q570	8-729-281-52	TRANSISTOR 2SC1815
Q571	8-729-900-65	TRANSISTOR DTA144ES
Q572	8-729-900-89	TRANSISTOR DTC144ES
Q601	8-729-141-89	TRANSISTOR 2SD1585-LK
Q602	8-729-922-37	TRANSISTOR 2SD2144S
Q603	8-729-224-62	TRANSISTOR 2SK246GR
Q604	8-729-900-80	TRANSISTOR DTC114ES
Q605	8-729-620-05	TRANSISTOR 2SC2603-EF
Q606	8-729-119-76	TRANSISTOR 2SA1175-HFE
Q607	8-729-224-62	TRANSISTOR 2SK246GR
Q608	8-729-141-32	TRANSISTOR 2SA1409-LK
Q609	8-729-141-83	TRANSISTOR 2SB1094-LK
Q610	8-729-900-80	TRANSISTOR DTC114ES
Q611	8-729-900-61	TRANSISTOR DTA114ES
Q701	8-729-141-32	TRANSISTOR 2SA1409-LK
Q702	8-729-140-04	TRANSISTOR 2SB1116A-LK
Q703	8-729-920-24	TRANSISTOR DTD114ES
Q704	8-729-922-37	TRANSISTOR 2SD2144S
Q705	8-729-620-05	TRANSISTOR 2SC2603-EF
Q706	8-729-920-98	TRANSISTOR 2SD1761-EF
Q707	8-729-620-05	TRANSISTOR 2SC2603-EF
Q708	8-729-920-98	TRANSISTOR 2SD1761-EF
Q709	8-729-920-98	TRANSISTOR 2SD1761-EF
Q710	8-729-922-37	TRANSISTOR 2SD2144S
Q801	8-729-900-61	TRANSISTOR DTA114ES
Q802	8-729-900-61	TRANSISTOR DTA114ES
Q803	8-729-900-61	TRANSISTOR DTA114ES
Q804	8-729-900-61	TRANSISTOR DTA114ES
Q805	8-729-900-61	TRANSISTOR DTA114ES
Q806	8-729-900-61	TRANSISTOR DTA114ES
Q807	8-729-900-61	TRANSISTOR DTA114ES
Q808	8-729-119-76	TRANSISTOR 2SA1175-HFE
Q809	8-729-900-80	TRANSISTOR DTC114ES
Q810	8-729-620-05	TRANSISTOR 2SC2603-EF
Q811	8-729-620-05	TRANSISTOR 2SC2603-EF

Ref.No.	Part No.	Description	Ref.No.	Part No.	Description
Q812	8-729-900-61	TRANSISTOR DTA114ES	R138	1-249-408-11	CARBON 180 5% 1/4W
Q813	8-729-900-61	TRANSISTOR DTA114ES	R140	1-249-429-11	CARBON 10K 5% 1/4W
Q814	8-729-900-61	TRANSISTOR DTA114ES	R141	1-259-452-11	CARBON 10K 5% 1/6W
Q815	8-729-900-61	TRANSISTOR DTA114ES	R142	1-259-440-11	CARBON 3.3K 5% 1/6W
Q816	8-729-119-76	TRANSISTOR 2SA1175-HFE	R143	1-259-460-11	CARBON 22K 5% 1/6W
Q901	8-729-900-61	TRANSISTOR DTA114ES	R144	1-247-704-11	CARBON 220 5% 1/4W
Q902	8-729-900-61	TRANSISTOR DTA114ES	R149	1-249-425-11	CARBON 4.7K 5% 1/4W
Q903	8-729-900-61	TRANSISTOR DTA114ES	R150	1-247-713-11	CARBON 1K 5% 1/4W
Q904	8-729-900-61	TRANSISTOR DTA114ES	R152	1-249-586-11	CARBON 27K 5% 1/4W
Q905	8-729-920-26	TRANSISTOR DTB114ES	R153	1-249-469-11	CARBON 100K 5% 1/4W
Q906	8-729-920-26	TRANSISTOR DTB114ES	R154	1-249-427-11	CARBON 6.8K 5% 1/4W
Q907	8-729-900-80	TRANSISTOR DTC114ES	R155	1-249-424-11	CARBON 3.9K 5% 1/4W
Q908	8-729-620-05	TRANSISTOR 2SC2603-EF	R156	1-249-423-11	CARBON 3.3K 5% 1/4W
Q909	8-729-620-05	TRANSISTOR 2SC2603-EF	R157	1-247-852-11	CARBON 7.5K 5% 1/4W
Q910	8-729-900-61	TRANSISTOR DTA114ES	R158	1-249-462-11	CARBON 22K 5% 1/4W
Q911	8-729-900-61	TRANSISTOR DTA114ES	R159	1-249-437-11	CARBON 47K 5% 1/4W
Q912	8-729-900-80	TRANSISTOR DTC114ES	R161	1-247-706-11	CARBON 330 5% 1/4W
Q913	8-729-900-80	TRANSISTOR DTC114ES	R162	1-247-725-11	CARBON 10K 5% 1/4W
Q914	8-729-900-61	TRANSISTOR DTA114ES	R163	1-247-148-00	CARBON 5.1K 5% 1/4W
Q915	8-729-900-61	TRANSISTOR DTA114ES	R164	1-247-718-11	CARBON 2.7K 5% 1/4W
Q916	8-729-900-61	TRANSISTOR DTA114ES	R165	1-246-545-00	CARBON 1M 5% 1/4W
Q917	8-729-900-61	TRANSISTOR DTA114ES	R166	1-247-710-11	CARBON 560 5% 1/4W
Q918	8-729-900-61	TRANSISTOR DTA114ES	R167	1-249-462-11	CARBON 22K 5% 1/4W
Q919	8-729-900-80	TRANSISTOR DTC114ES	R168	1-247-852-11	CARBON 7.5K 5% 1/4W
Q920	8-729-900-61	TRANSISTOR DTA114ES	R169	1-247-854-11	CARBON 9.1K 5% 1/4W
Q921	8-729-900-80	TRANSISTOR DTC114ES	R170	1-249-415-11	CARBON 680 5% 1/4W
Q922	8-729-900-89	TRANSISTOR DTC144ES	R171	1-247-721-11	CARBON 4.7K 5% 1/4W
Q923	8-729-900-89	TRANSISTOR DTC144ES	R172	1-247-719-11	CARBON 3.3K 5% 1/4W
R101	1-249-469-11	CARBON 100K 5% 1/4W	R173	1-249-421-11	CARBON 2.2K 5% 1/4W
R102	1-247-703-11	CARBON 180 5% 1/4W	R174	1-247-723-11	CARBON 6.8K 5% 1/4W
R103	1-249-603-11	CARBON 130K 5% 1/4W	R175	1-249-590-11	CARBON 39K 5% 1/4W
R104	1-247-722-11	CARBON 5.6K 5% 1/4W	R176	1-249-429-11	CARBON 10K 5% 1/4W
R105	1-247-716-11	CARBON 1.8K 5% 1/4W	R177	1-249-437-11	CARBON 47K 5% 1/4W
R106	1-247-138-00	CARBON 2K 5% 1/4W	R178	1-249-438-11	CARBON 56K 5% 1/4W
R108	1-249-429-11	CARBON 10K 5% 1/4W	R179	1-249-435-11	CARBON 33K 5% 1/4W
R109	1-247-717-11	CARBON 2.2K 5% 1/4W	R180	1-247-721-11	CARBON 4.7K 5% 1/4W
R110	1-249-465-11	CARBON 47K 5% 1/4W	R181	1-249-407-11	CARBON 150 5% 1/4W
R111	1-247-710-11	CARBON 560 5% 1/4W	R182	1-249-429-11	CARBON 10K 5% 1/4W
R112	1-247-725-11	CARBON 10K 5% 1/4W	R183	1-247-846-11	CARBON 4.3K 5% 1/4W
R113	1-247-718-11	CARBON 2.7K 5% 1/4W	R184	1-249-406-11	CARBON 120 5% 1/4W
R114	1-247-148-00	CARBON 5.1K 5% 1/4W	R185	1-249-427-11	CARBON 6.8K 5% 1/4W
R115	1-246-545-00	CARBON 1M 5% 1/4W	R186	1-247-848-11	CARBON 5.1K 5% 1/4W
R116	1-247-710-11	CARBON 560 5% 1/4W	R187	1-249-411-11	CARBON 330 5% 1/4W
R117	1-249-462-11	CARBON 22K 5% 1/4W	R189	1-249-421-11	CARBON 2.2K 5% 1/4W
R118	1-247-852-11	CARBON 7.5K 5% 1/4W	R190	1-249-429-11	CARBON 10K 5% 1/4W
R119	1-249-415-11	CARBON 680 5% 1/4W	R191	1-249-429-11	CARBON 10K 5% 1/4W
R120	1-247-854-11	CARBON 9.1K 5% 1/4W	R192	1-249-429-11	CARBON 10K 5% 1/4W
R121	1-249-465-11	CARBON 47K 5% 1/4W	R193	1-249-432-11	CARBON 18K 5% 1/4W
R122	1-249-465-11	CARBON 47K 5% 1/4W	R194	1-249-393-11	CARBON 10 5% 1/4W
R123	1-249-429-11	CARBON 10K 5% 1/4W	R195	1-249-435-11	CARBON 33K 5% 1/4W
R124	1-249-421-11	CARBON 2.2K 5% 1/4W	R196	1-247-883-00	CARBON 150K 5% 1/4W
R131	1-249-421-11	CARBON 2.2K 5% 1/4W	R197	1-249-465-11	CARBON 47K 5% 1/4W
R132	1-247-717-11	CARBON 2.2K 5% 1/4W	R198	1-247-725-11	CARBON 10K 5% 1/4W
R133	1-249-421-11	CARBON 2.2K 5% 1/4W	R201	1-249-469-11	CARBON 100K 5% 1/4W
R134	1-215-454-00	METAL 24K 1% 1/6W	R202	1-247-703-11	CARBON 180 5% 1/4W
R135	1-249-462-11	CARBON 22K 5% 1/4W	R203	1-249-603-11	CARBON 130K 5% 1/4W
R136	1-215-453-00	METAL 22K 1% 1/6W	R204	1-247-722-11	CARBON 5.6K 5% 1/4W
R137	1-215-457-00	METAL 33K 1% 1/6W			

Ref.No.	Part No.	Description					
R205	1-247-716-11	CARBON	1.8K	5%	1/4W		
R206	1-247-138-00	CARBON	2K	5%	1/4W		
R208	1-249-429-11	CARBON	10K	5%	1/4W		
R209	1-247-717-11	CARBON	2.2K	5%	1/4W		
R210	1-249-465-11	CARBON	47K	5%	1/4W		
R211	1-247-710-11	CARBON	560	5%	1/4W		
R212	1-247-725-11	CARBON	10K	5%	1/4W		
R213	1-247-718-11	CARBON	2.7K	5%	1/4W		
R214	1-247-148-00	CARBON	5.1K	5%	1/4W		
R215	1-246-545-00	CARBON	1M	5%	1/4W		
R216	1-247-710-11	CARBON	560	5%	1/4W		
R217	1-249-462-11	CARBON	22K	5%	1/4W		
R218	1-247-852-11	CARBON	7.5K	5%	1/4W		
R219	1-249-415-11	CARBON	680	5%	1/4W		
R220	1-247-854-11	CARBON	9.1K	5%	1/4W		
R221	1-249-465-11	CARBON	47K	5%	1/4W		
R222	1-249-465-11	CARBON	47K	5%	1/4W		
R223	1-249-429-11	CARBON	10K	5%	1/4W		
R224	1-249-421-11	CARBON	2.2K	5%	1/4W		
R231	1-249-421-11	CARBON	2.2K	5%	1/4W		
R232	1-247-717-11	CARBON	2.2K	5%	1/4W		
R233	1-249-421-11	CARBON	2.2K	5%	1/4W		
R234	1-215-454-00	METAL	24K	1%	1/6W		
R235	1-249-462-11	CARBON	22K	5%	1/4W		
R236	1-215-453-00	METAL	22K	1%	1/6W		
R237	1-215-457-00	METAL	33K	1%	1/6W		
R238	1-249-408-11	CARBON	180	5%	1/4W		
R240	1-249-429-11	CARBON	10K	5%	1/4W		
R241	1-259-452-11	CARBON	10K	5%	1/6W		
R242	1-259-440-11	CARBON	3.3K	5%	1/6W		
R243	1-259-460-11	CARBON	22K	5%	1/6W		
R244	1-247-704-11	CARBON	220	5%	1/4W		
R249	1-249-425-11	CARBON	4.7K	5%	1/4W		
R250	1-247-713-11	CARBON	1K	5%	1/4W		
R252	1-249-586-11	CARBON	27K	5%	1/4W		
R253	1-249-469-11	CARBON	100K	5%	1/4W		
R254	1-249-427-11	CARBON	6.8K	5%	1/4W		
R255	1-249-424-11	CARBON	3.9K	5%	1/4W		
R256	1-249-423-11	CARBON	3.3K	5%	1/4W		
R257	1-247-852-11	CARBON	7.5K	5%	1/4W		
R258	1-249-462-11	CARBON	22K	5%	1/4W		
R259	1-249-437-11	CARBON	47K	5%	1/4W		
R261	1-247-706-11	CARBON	330	5%	1/4W		
R262	1-247-725-11	CARBON	10K	5%	1/4W		
R263	1-247-148-00	CARBON	5.1K	5%	1/4W		
R264	1-247-718-11	CARBON	2.7K	5%	1/4W		
R265	1-246-545-00	CARBON	1M	5%	1/4W		
R266	1-247-710-11	CARBON	560	5%	1/4W		
R267	1-249-462-11	CARBON	22K	5%	1/4W		
R268	1-247-852-11	CARBON	7.5K	5%	1/4W		
R269	1-247-854-11	CARBON	9.1K	5%	1/4W		
R270	1-249-415-11	CARBON	680	5%	1/4W		
R271	1-247-721-11	CARBON	4.7K	5%	1/4W		
R272	1-247-719-11	CARBON	3.3K	5%	1/4W		
R273	1-249-421-11	CARBON	2.2K	5%	1/4W		
R274	1-247-723-11	CARBON	6.8K	5%	1/4W		
R275	1-249-590-11	CARBON	39K	5%	1/4W		
R276	1-249-429-11	CARBON	10K	5%	1/4W		
R277	1-249-437-11	CARBON	47K	5%	1/4W		
R278	1-249-438-11	CARBON	56K	5%	1/4W		
R279	1-249-435-11	CARBON	33K	5%	1/4W		
R280	1-247-721-11	CARBON	4.7K	5%	1/4W		
R281	1-249-407-11	CARBON	150	5%	1/4W		
R282	1-249-429-11	CARBON	10K	5%	1/4W		
R283	1-247-846-11	CARBON	4.3K	5%	1/4W		
R284	1-249-406-11	CARBON	120	5%	1/4W		
R285	1-249-427-11	CARBON	6.8K	5%	1/4W		
R286	1-247-848-11	CARBON	5.1K	5%	1/4W		
R287	1-249-411-11	CARBON	330	5%	1/4W		
R289	1-249-421-11	CARBON	2.2K	5%	1/4W		
R290	1-249-429-11	CARBON	10K	5%	1/4W		
R291	1-249-429-11	CARBON	10K	5%	1/4W		
R292	1-249-429-11	CARBON	10K	5%	1/4W		
R293	1-249-432-11	CARBON	18K	5%	1/4W		
R294	1-249-393-11	CARBON	10	5%	1/4W		
R295	1-249-435-11	CARBON	33K	5%	1/4W		
R296	1-247-883-00	CARBON	150K	5%	1/4W		
R297	1-249-465-11	CARBON	47K	5%	1/4W		
R298	1-247-725-11	CARBON	10K	5%	1/4W		
R501	1-249-429-11	CARBON	10K	5%	1/4W		
R502	1-249-437-11	CARBON	47K	5%	1/4W		
R503	1-215-472-00	METAL	130K	1%	1/6W		
R504	1-249-437-11	CARBON	47K	5%	1/4W		
R505	1-249-429-11	CARBON	10K	5%	1/4W		
R506	1-249-429-11	CARBON	10K	5%	1/4W		
R507	1-249-431-11	CARBON	15K	5%	1/4W		
R508	1-249-417-11	CARBON	1K	5%	1/4W		
R509	1-249-437-11	CARBON	47K	5%	1/4W		
R510	1-249-413-11	CARBON	470	5%	1/4W		
R511	1-249-432-11	CARBON	18K	5%	1/4W		
R512	1-249-433-11	CARBON	22K	5%	1/4W		
R513	1-249-417-11	CARBON	1K	5%	1/4W		
R514	1-249-437-11	CARBON	47K	5%	1/4W		
R516	1-249-433-11	CARBON	22K	5%	1/4W		
R517	1-249-437-11	CARBON	47K	5%	1/4W		
R521	1-249-425-11	CARBON	4.7K	5%	1/4W		
R522	1-249-425-11	CARBON	4.7K	5%	1/4W		
R523	1-249-437-11	CARBON	47K	5%	1/4W		
R524	1-249-437-11	CARBON	47K	5%	1/4W		
R525	1-249-437-11	CARBON	47K	5%	1/4W		
R526	1-249-435-11	CARBON	33K	5%	1/4W		
R527	1-249-439-11	CARBON	68K	5%	1/4W		
R528	1-249-429-11	CARBON	10K	5%	1/4W		
R529	1-249-425-11	CARBON	4.7K	5%	1/4W		
R531	1-249-437-11	CARBON	47K	5%	1/4W		
R532	1-249-433-11	CARBON	22K	5%	1/4W		
R533	1-249-433-11	CARBON	22K	5%	1/4W		
R551	1-215-472-00	METAL	130K	1%	1/6W		
R552	1-249-429-11	CARBON	10K	5%	1/4W		
R553	1-249-421-11	CARBON	2.2K	5%	1/4W		
R554	1-249-440-11	CARBON	82K	5%	1/4W		
R555	1-249-429-11	CARBON	10K	5%	1/4W		
R560	1-249-391-11	CARBON	6.8	5%	1/4W		
R561	1-249-391-11	CARBON	6.8	5%	1/4W		

Ref.No.	Part No.	Description				
R562	1-249-440-11	CARBON	82K	5%	1/4W	
R563	1-249-440-11	CARBON	82K	5%	1/4W	
R564	1-249-429-11	CARBON	10K	5%	1/4W	
R565	1-249-425-11	CARBON	4.7K	5%	1/4W	
R566	1-249-418-11	CARBON	1.2K	5%	1/4W	
R567	1-249-437-11	CARBON	47K	5%	1/4W	
R568	1-247-838-00	CARBON	2K	5%	1/4W	
R569	1-249-425-11	CARBON	4.7K	5%	1/4W	
R570	1-249-425-11	CARBON	4.7K	5%	1/4W	
R571	1-249-423-11	CARBON	3.3K	5%	1/4W	
R572	1-247-856-00	CARBON	11K	5%	1/4W	
R573	1-247-856-00	CARBON	11K	5%	1/4W	
R574	1-249-397-11	CARBON	22	5%	1/4W	
R575	1-249-406-11	CARBON	120	5%	1/4W	
R576	1-247-887-00	CARBON	220K	5%	1/4W	
R577	1-249-437-11	CARBON	47K	5%	1/4W	
R578	1-249-432-11	CARBON	18K	5%	1/4W	
R579	1-249-432-11	CARBON	18K	5%	1/4W	
R580	1-249-397-11	CARBON	22	5%	1/4W	
R581	1-249-406-11	CARBON	120	5%	1/4W	
R582	1-247-887-00	CARBON	220K	5%	1/4W	
R583	1-249-407-11	CARBON	150	5%	1/4W	
R584	1-249-427-11	CARBON	6.8K	5%	1/4W	
R585	1-249-381-11	CARBON	1	5%	1/4W	
R586	1-249-422-11	CARBON	2.7K	5%	1/4W	
R602	1-247-717-11	CARBON	2.2K	5%	1/4W	
R603	1-247-717-11	CARBON	2.2K	5%	1/4W	
R604	1-247-706-11	CARBON	330	5%	1/4W	
R605	1-249-556-11	CARBON	1.5K	5%	1/4W	
R606	1-249-556-11	CARBON	1.5K	5%	1/4W	
R607	1-247-717-11	CARBON	2.2K	5%	1/4W	
R608	1-249-926-11	CARBON	1.3K	5%	1/4W	
R609	△1-217-637-00	FUSIBLE	1	5%	1/4W	F
R610	1-249-417-11	CARBON	1K	5%	1/4W	
R701	1-249-425-11	CARBON	4.7K	5%	1/4W	
R702	1-249-429-11	CARBON	10K	5%	1/4W	
R703	1-249-431-11	CARBON	15K	5%	1/4W	
R704	1-249-425-11	CARBON	4.7K	5%	1/4W	
R705	1-249-421-11	CARBON	2.2K	5%	1/4W	
R706	1-249-421-11	CARBON	2.2K	5%	1/4W	
R707	1-249-421-11	CARBON	2.2K	5%	1/4W	
R708	1-249-427-11	CARBON	6.8K	5%	1/4W	
R709	1-249-425-11	CARBON	4.7K	5%	1/4W	
R710	1-247-752-11	CARBON	1K	5%	1/2W	
R711	1-249-429-11	CARBON	10K	5%	1/4W	
R712	1-249-421-11	CARBON	2.2K	5%	1/4W	
R713	1-249-437-11	CARBON	47K	5%	1/4W	
R714	1-249-425-11	CARBON	4.7K	5%	1/4W	
R715	1-249-421-11	CARBON	2.2K	5%	1/4W	
R801	1-247-887-00	CARBON	220K	5%	1/4W	
R802	1-247-887-00	CARBON	220K	5%	1/4W	
R803	1-249-436-11	CARBON	39K	5%	1/4W	
R804	1-249-436-11	CARBON	39K	5%	1/4W	
R805	1-249-429-11	CARBON	10K	5%	1/4W	
R806	1-249-435-11	CARBON	33K	5%	1/4W	
R807	1-249-429-11	CARBON	10K	5%	1/4W	
R808	1-249-429-11	CARBON	10K	5%	1/4W	

Ref.No.	Part No.	Description				
R809	△1-249-484-11	CARBON	6.8	5%	1/2W	F
R810	1-247-854-11	CARBON	9.1K	5%	1/4W	
R811	1-249-429-11	CARBON	10K	5%	1/4W	
R812	△1-249-484-11	CARBON	6.8	5%	1/2W	F
R813	1-249-429-11	CARBON	10K	5%	1/4W	
R814	1-249-429-11	CARBON	10K	5%	1/4W	
R815	1-249-425-11	CARBON	4.7K	5%	1/4W	
R816	1-249-413-11	CARBON	470	5%	1/4W	
R817	1-249-429-11	CARBON	10K	5%	1/4W	
R818	1-249-429-11	CARBON	10K	5%	1/4W	
R819	1-249-429-11	CARBON	10K	5%	1/4W	
R820	1-249-429-11	CARBON	10K	5%	1/4W	
R821	1-249-429-11	CARBON	10K	5%	1/4W	
R822	1-249-429-11	CARBON	10K	5%	1/4W	
R823	1-249-429-11	CARBON	10K	5%	1/4W	
R824	1-249-429-11	CARBON	10K	5%	1/4W	
R825	1-249-429-11	CARBON	10K	5%	1/4W	
R826	1-249-429-11	CARBON	10K	5%	1/4W	
R827	1-249-425-11	CARBON	4.7K	5%	1/4W	
R828	1-249-425-11	CARBON	4.7K	5%	1/4W	
R829	1-249-435-11	CARBON	33K	5%	1/4W	
R830	1-249-413-11	CARBON	470	5%	1/4W	
R832	1-247-903-00	CARBON	1M	5%	1/4W	
R833	1-249-417-11	CARBON	1K	5%	1/4W	
R834	1-249-425-11	CARBON	4.7K	5%	1/4W	
R835	1-249-435-11	CARBON	33K	5%	1/4W	
R836	1-249-440-11	CARBON	82K	5%	1/4W	
R837	1-249-435-11	CARBON	33K	5%	1/4W	
R838	1-249-437-11	CARBON	47K	5%	1/4W	
R839	1-249-435-11	CARBON	33K	5%	1/4W	
R840	1-249-435-11	CARBON	33K	5%	1/4W	
R841	1-249-429-11	CARBON	10K	5%	1/4W	
R842	1-249-429-11	CARBON	10K	5%	1/4W	
R843	1-249-429-11	CARBON	10K	5%	1/4W	
R844	1-249-408-11	CARBON	180	5%	1/4W	
R845	1-249-411-11	CARBON	330	5%	1/4W	
R846	1-249-408-11	CARBON	180	5%	1/4W	
R847	1-249-435-11	CARBON	33K	5%	1/4W	
R848	1-249-435-11	CARBON	33K	5%	1/4W	
R849	1-249-427-11	CARBON	6.8K	5%	1/4W	
R901	1-249-441-11	CARBON	100K	5%	1/4W	
R902	1-249-441-11	CARBON	100K	5%	1/4W	
R903	1-249-441-11	CARBON	100K	5%	1/4W	
R904	1-249-441-11	CARBON	100K	5%	1/4W	
R905	1-249-441-11	CARBON	100K	5%	1/4W	
R906	1-249-441-11	CARBON	100K	5%	1/4W	
R907A	1-249-441-11	CARBON	100K	5%	1/4W	
R907B	1-216-242-00	METAL GLAZE	68K	5%	1/8W	
R908A	1-249-441-11	CARBON	100K	5%	1/4W	
R908B	1-216-246-00	METAL GLAZE	100K	5%	1/8W	
R909A	1-249-441-11	CARBON	100K	5%	1/4W	
R909B	1-216-246-00	METAL GLAZE	100K	5%	1/8W	
R910A	1-249-441-11	CARBON	100K	5%	1/4W	
R910B	1-216-238-00	METAL GLAZE	47K	5%	1/8W	
R911B	1-216-182-00	METAL GLAZE	220	5%	1/8W	

Note: The components identified by mark  or dotted line with mark  are critical for safety. Replace only with part number specified.

Ref.No.	Part No.	Description				
R912A	1-249-441-11	CARBON	100K	5%	1/4W	
R912B	1-216-182-00	METAL GLAZE	220	5%	1/8W	
R913A	1-249-441-11	CARBON	100K	5%	1/4W	
R913B	1-216-150-00	METAL GLAZE	10	5%	1/8W	
R914A	1-249-441-11	CARBON	100K	5%	1/4W	
R914B	1-216-150-00	METAL GLAZE	10	5%	1/8W	
R915A	1-249-441-11	CARBON	100K	5%	1/4W	
R915B	1-216-150-00	METAL GLAZE	10	5%	1/8W	
R916	1-249-441-11	CARBON	100K	5%	1/4W	
R917	1-249-441-11	CARBON	100K	5%	1/4W	
R918	1-249-441-11	CARBON	100K	5%	1/4W	
R919	1-249-441-11	CARBON	100K	5%	1/4W	
R920	1-249-441-11	CARBON	100K	5%	1/4W	
R922	1-247-903-00	CARBON	1M	5%	1/4W	
R923	1-215-452-00	METAL	20K	1%	1/6W	
R924	1-215-452-00	METAL	20K	1%	1/6W	
R925	1-215-445-00	METAL	10K	1%	1/6W	
R926	1-215-452-00	METAL	20K	1%	1/6W	
R927	1-215-445-00	METAL	10K	1%	1/6W	
R928	1-215-452-00	METAL	20K	1%	1/6W	
R929	1-215-445-00	METAL	10K	1%	1/6W	
R930	1-215-452-00	METAL	20K	1%	1/6W	
R931	1-215-445-00	METAL	10K	1%	1/6W	
R932	1-215-452-00	METAL	20K	1%	1/6W	
R933	1-215-445-00	METAL	10K	1%	1/6W	
R934	1-215-452-00	METAL	20K	1%	1/6W	
R935	1-215-445-00	METAL	10K	1%	1/6W	
R936	1-215-460-00	METAL	43K	1%	1/6W	
R937	1-215-425-00	METAL	1.5K	1%	1/6W	
R938	1-249-429-11	CARBON	10K	5%	1/4W	
R939	1-249-409-11	CARBON	220	5%	1/4W	
R940	1-249-429-11	CARBON	10K	5%	1/4W	
R941	1-249-429-11	CARBON	10K	5%	1/4W	
R942	1-249-422-11	CARBON	2.7K	5%	1/4W	
R943	1-249-424-11	CARBON	3.9K	5%	1/4W	
R944	1-249-428-11	CARBON	8.2K	5%	1/4W	
R945	1-249-434-11	CARBON	27K	5%	1/4W	
R946	1-249-422-11	CARBON	2.7K	5%	1/4W	
R947	1-249-424-11	CARBON	3.9K	5%	1/4W	
R948	1-249-428-11	CARBON	8.2K	5%	1/4W	
R949	1-249-434-11	CARBON	27K	5%	1/4W	
R950	1-249-427-11	CARBON	6.8K	5%	1/4W	
R951A	1-249-428-11	CARBON	8.2K	5%	1/4W	
R951B	1-249-413-11	CARBON	470	5%	1/4W	
R952A	1-249-425-11	CARBON	4.7K	5%	1/4W	
R952B	1-249-413-11	CARBON	470	5%	1/4W	
R953A	1-249-429-11	CARBON	10K	5%	1/4W	
R953B	1-247-881-00	CARBON	120K	5%	1/4W	
R954A	1-249-429-11	CARBON	10K	5%	1/4W	
R954B	1-247-881-00	CARBON	120K	5%	1/4W	
R955A	1-249-425-11	CARBON	4.7K	5%	1/4W	
R955B	1-249-429-11	CARBON	10K	5%	1/4W	
R956A	1-249-425-11	CARBON	4.7K	5%	1/4W	
R956B	1-249-417-11	CARBON	1K	5%	1/4W	

Ref.No.	Part No.	Description			
R957	1-249-417-11	CARBON	1K	5%	1/4W
R958	1-247-891-00	CARBON	330K	5%	1/4W
R959	1-247-901-11	CARBON	820K	5%	1/4W
R960	1-249-441-11	CARBON	100K	5%	1/4W
R1001	1-249-408-11	CARBON	180	5%	1/4W
R1002	1-249-408-11	CARBON	180	5%	1/4W
R1051	1-249-412-11	CARBON	390	5%	1/4W
RV101	1-228-993-00	RES, ADJ, CARBON	5K		
RV131	1-228-995-00	RES, ADJ, CARBON	22K		
RV151	1-228-994-00	RES, ADJ, CARBON	10K		
RV153	1-228-995-00	RES, ADJ, CARBON	22K		
RV201	1-228-993-00	RES, ADJ, CARBON	5K		
RV231	1-228-995-00	RES, ADJ, CARBON	22K		
RV251	1-228-994-00	RES, ADJ, CARBON	10K		
RV253	1-228-995-00	RES, ADJ, CARBON	22K		
RV541	1-238-085-11	REA, VAR, CARBON	20K/20K		
RV551	1-238-687-11	RES, VAR, CARBON	50K/50K		
RV552	1-238-833-21	RES, VAR, CARBON	20K/20K		
RV553	1-238-832-11	RES, VAR, CARBON	5K/5K		
RV561	1-238-834-11	RES, VAR, CARBON	5K/5K		
RV571	1-230-504-11	RES, ADJ, CARBON	220		
RV572	1-230-504-11	RES, ADJ, CARBON	220		
RV573	1-228-993-00	RES, ADJ, CARBON	4.7K		
RV574	1-228-996-00	RES, ADJ, CARBON	47K		
RV803	1-228-993-00	RES, ADJ, CARBON	4.7K		
S522	1-572-154-11	SWITCH, ROTARY (DOLBY NR)			
S523	1-572-387-11	SWITCH, PUSH (2 KEY) (MPX FILTER/CALIBRATION)			
S701	Δ1-570-103-21	SWITCH, PUSH (1 KEY)(POWER)			
S801	1-516-781-XX	SWITCH, SLIDE (TIMER)			
S901	1-554-303-21	SWITCH, KEY BOARD (COUNTER RESET)			
S902	1-554-303-21	SWITCH, KEY BOARD (COUNTER MEMORY)			
S903	1-554-303-21	SWITCH, KEY BOARD (OPEN/CLOSE)			
S904	1-554-303-21	SWITCH, KEY BOARD (■)			
S905	1-554-303-21	SWITCH, KEY BOARD (◀)			
S906	1-554-303-21	SWITCH, KEY BOARD (▶)			
S907	1-554-303-21	SWITCH, KEY BOARD (●)			
S908	1-554-303-21	SWITCH, KEY BOARD (▶)			
S909	1-554-303-21	SWITCH, KEY BOARD (  )			
S910	1-554-303-21	SWITCH, KEY BOARD (◀)			
S911	1-554-303-21	SWITCH, KEY BOARD (▶)			
S912	1-554-303-21	SWITCH, KEY BOARD (◉)			
S913	1-554-303-21	SWITCH, KEY BOARD (DISPLAY)			
S914	1-554-303-21	SWITCH, KEY BOARD (MONITOR)			
S1001	1-466-238-11	ENCODER, ROTARY			
S1002	1-570-953-11	SWITCH, PUSH (1 KEY)(DOOR)			
S1003	1-571-958-11	SWITCH, PUSH (1 KEY)(CLOSE)			
S1004	1-572-126-11	SWITCH, PUSH (1 KEY)(OPEN)			
S1005	1-572-125-11	SWITCH, LEAF (FWD)			
S1006	1-572-202-11	SWITCH, LEAF (HALF)			
S1007	1-572-125-11	SWITCH, LEAF (METAL)			
S1008	1-572-125-11	SWITCH, LEAF (70U)			
T151	1-433-371-11	TRANSFORMER, BIAS OSCILLATION			
T251	1-433-371-11	TRANSFORMER, BIAS OSCILLATION			
T561	1-433-359-11	TRANSFORMER, BIAS OSCILLATION			
T701	Δ1-449-986-11	TRANSFORMER, POWER			
TB1001*	1-569-066-11	PIN, CONNECTOR 5P			

Note: The components identified by mark  $\Delta$  or dotted line with mark  $\Delta$  are critical for safety. Replace only with part number specified.

<u>Ref.No.</u>	<u>Part No.</u>	<u>Description</u>
X801	1-577-358-21	VIBRATOR, CERAMIC (4MHz)
X901	1-577-101-11	VIBRATOR, CERAMIC (4.19MHz)
X951	1-577-615-11	VIBRATOR, CRYSTAL (4.934MHz)

ACCESSORY & PACKING MATERIAL

1-551-734-11	CORD, CONNECTION (RK-74A)
3-751-725-11	(AEP).....MANUAL, INSTRUCTION
3-751-725-41	(AEP).....MANUAL, INSTRUCTION
3-751-725-51	(West Germany)...MANUAL, INSTRUCTION
*3-350-463-01	CUSHION
*3-350-464-51	INDIVIDUAL CARTON



