

TC-K520

SERVICE MANUAL

Canadian Model
AEP Model
UK Model

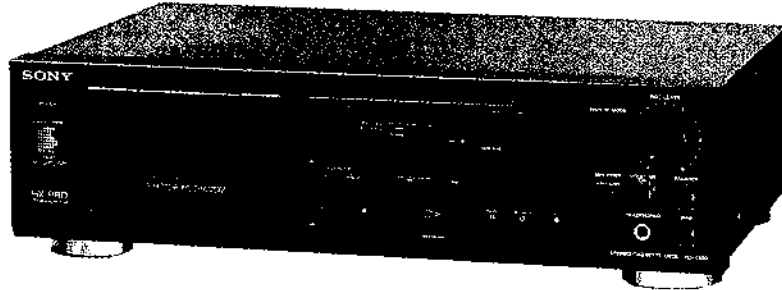

Model Name Using Similar Mechanism	TC-RX70/RX70ES
Tape Transport Mechanism Type	TCM-200V1

SPECIFICATIONS

Recording system 4-track 2-channel stereo
 Bias AC bias
 Wow and flutter $\pm 0.16\%$ W Peak (DIN)
 Fast-forward and rewind time
 Approx. 90 sec. (with C-60 cassette)

Frequency response (DOLBY NR off)

TYPE IV cassette (Sony METAL-ES)	25 - 19,000 Hz (± 3 dB, DIN) 30 - 15,000 Hz (OVU recording, ± 3 dB)
TYPE II cassette (Sony UX-S)	25 - 17,000 Hz (± 3 dB, DIN) 15 - 18,000 Hz
TYPE I cassette (Sony HF-S)	25 - 16,000 Hz (± 3 dB, DIN) 15 - 17,000 Hz

Signal-to-noise ratio (at peak level)

Cassette	Dolby NR switch		
	OFF	B-TYPE ON	C-TYPE ON
TYPE IV (Sony METAL-ES)	59 dB	67 dB	74 dB
TYPE II (Sony UX-S)	58 dB	66 dB	73 dB
TYPE I (Sony HF-S)	56 dB	64 dB	71 dB

Total harmonic distortion

1.0% (with Sony METAL-ES cassette)

Inputs

Line inputs (phono jacks)	Sensitivity	77.5 mV (-20 dB)
	Input impedance	50k ohms

Outputs

Line outputs (phono jacks)	Rated output level	0.44 V (-5 dB) at a load impedance 47k ohms
	Load impedance	Over 10k ohms
Headphones (stereo phone jack)	Output level	0.3 mW at a load impedance of 32 ohms

General

Power requirements AEP, West Germany models:
220 V AC, 50/60 Hz
UK model:
240 V AC, 50 Hz
Canadian model:
120 V AC, 60 Hz

Power consumption AEP, West Germany, UK models:
20 W
Canadian model: 19 W

Dimensions Approx. 430 x 123 x 285 mm (w/h/d)
(17 x 4 7/8 x 11 1/4 inches)

Weight Approx. 4.7 kg (10 lbs 6 oz)

Supplied accessory Audio connecting cord (2)

Design and specifications subject to change without notice.

Note

This appliance conforms with EEC Directive 87/308/EEC regarding interference suppression.

Dolby noise reduction manufactured under license from Dolby Laboratories Licensing Corporation. "DOLBY" and the double-D symbol  are trademarks of Dolby Laboratories Licensing Corporation.

STEREO CASSETTE DECK
SONY[®]

OPERATING VOLTAGE

Before connecting the unit to the power source, check that the operating voltage of your unit is the same as the local power line voltage.

The Canadian model operates on 120V AC.

The WG, AEP model operates on 220V AC.

The UK model operates on 240V AC.

MODEL IDENTIFICATION

– Specification Label –

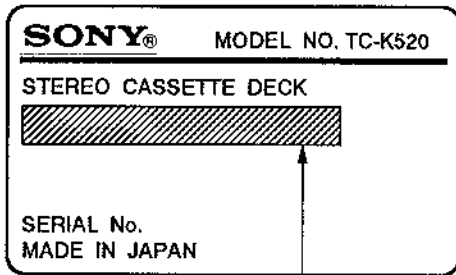



WG, AEP model: AC: 220 V ~50/60 Hz
 Canadian Model: AC: 120 V 60Hz 19 W
 UK model: AC: 240 V ~50/60 Hz

TABLE OF CONTENTS

<u>Section</u>	<u>Title</u>	<u>Page</u>
	Specifications	1
	Operating Voltage	2
1.	GENERAL	
	Identification of Front Panel Parts	3
2.	DISASSEMBLY	4
3.	MECHANICAL ADJUSTMENTS	7
4.	ELECTRICAL ADJUSTMENTS	7
	Record/Playback Head Azimuth Adjustment	7
	Tape Speed Adjustment	8
	Playback Level Adjustment	8
	Bias Consumption Current Adjustment	8
	Record Bias Adjustment	9
	Record Level Adjustment	9
5.	DIAGRAMS	
5-1.	Printed Wiring Boards	11
5-2.	Schematic Diagram	15
6.	EXPLODED VIEWS	21
7.	ELECTRICAL PARTS LIST	25

SAFETY-RELATED COMPONENT WARNING!!

COMPONENTS IDENTIFIED BY MARK  OR DOTTED LINE WITH MARK  ON THE SCHEMATIC DIAGRAMS AND IN THE PARTS LIST ARE CRITICAL TO SAFE OPERATION. REPLACE THESE COMPONENTS WITH SONY PARTS WHOSE PART NUMBERS APPEAR AS SHOWN IN THIS MANUAL OR IN SUPPLEMENTS PUBLISHED BY SONY.









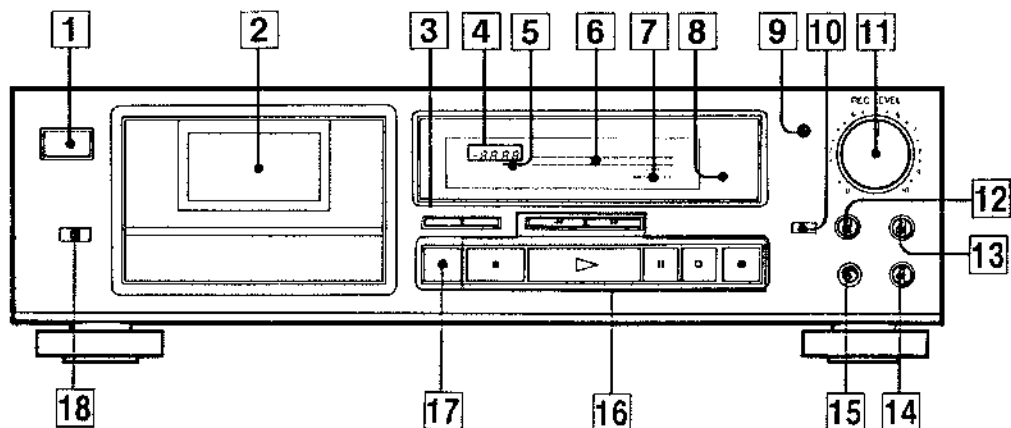

ATTENTION AU COMPOSANT AYANT RAPPORT À LA SÉCURITÉ!

LES COMPOSANTS IDENTIFIÉS PAR UNE MARQUE  SUR LES DIAGRAMMES SCHÉMATIQUES ET LA LISTE DES PIÈCES SONT CRITIQUES POUR LA SÉCURITÉ DE FONCTIONNEMENT. NE REMPLACER CES COMPOSANTS QUE PAR DES PIÈCES SONY DONT LES NUMÉROS SONT DONNÉS DANS CE MANUEL OU DANS LES SUPPLÉMENTS PUBLIÉS PAR SONY.

SECTION 1 GENERAL

Identification of Front Panel Parts



- | | |
|---|--|
| <p>1 POWER switch</p> <p>2 Cassette holder</p> <p>3 COUNTER buttons
RESET button/MEMORY button</p> <p>4 LINEAR COUNTER</p> <p>5 MEMORY indicator</p> <p>6 PEAK LEVEL METER</p> <p>7 TAPE TYPE indicator</p> <p>8 Remote sensor</p> <p>You can remotely control this cassette deck with:</p> <ul style="list-style-type: none"> — A remote commander that has an  mark and comes with a Sony amplifier or receiver and which can be used to control a cassette deck. — An optional Sony remote commander that has an  mark. <p>9 DISPLAY MODE button</p> <p>10 MPX FILTER switch</p> <p>11 REC LEVEL (recording level) control</p> <p>12 DOLBY NR switch</p> | <p>13 BALANCE control</p> <p>14 BIAS (bias adjust) control</p> <p>15 HEADPHONES jack (stereo phone jack)</p> <p>16 Tape operation buttons</p> <ul style="list-style-type: none">  (rewind) button  (fast-forward) button  (stop) button  (play) button (AMS*)  PAUSE button  REC MUTE (record muting) button  REC (record) button <p>17  OPEN/CLOSE button</p> <p>18 TIMER switch</p> |
|---|--|

* AMS is an abbreviation for Automatic Music Sensor.

SECTION 2 DISASSEMBLY

Note: Follow the disassembly procedure in the numerical order given.

Unscrew the four case attachment screws $M3 \times 8$ and remove the upper case.

MAIN BOARD

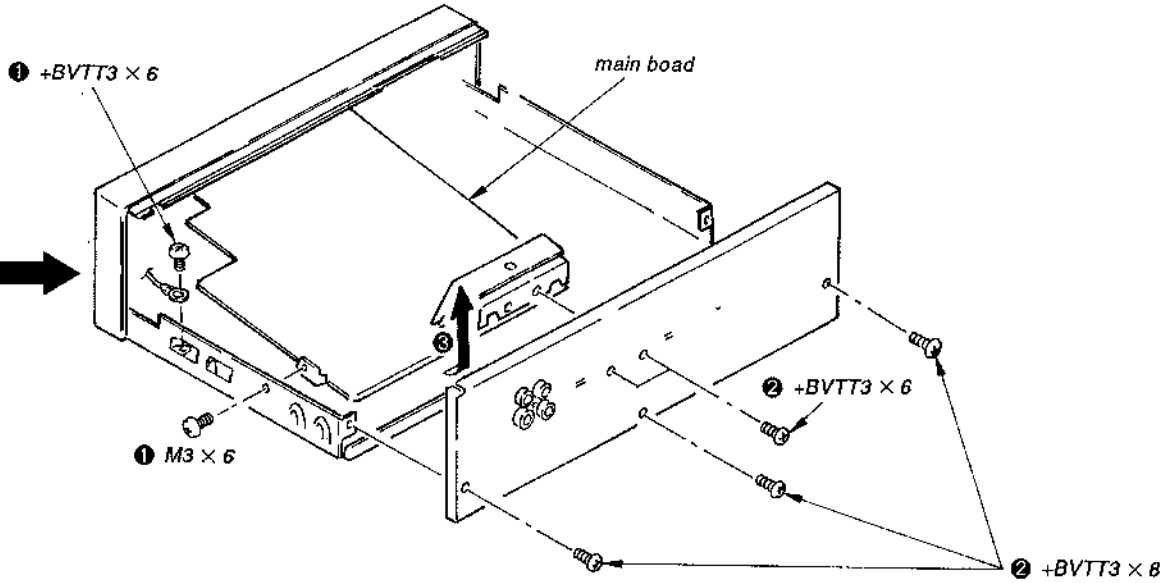

MECHANISM

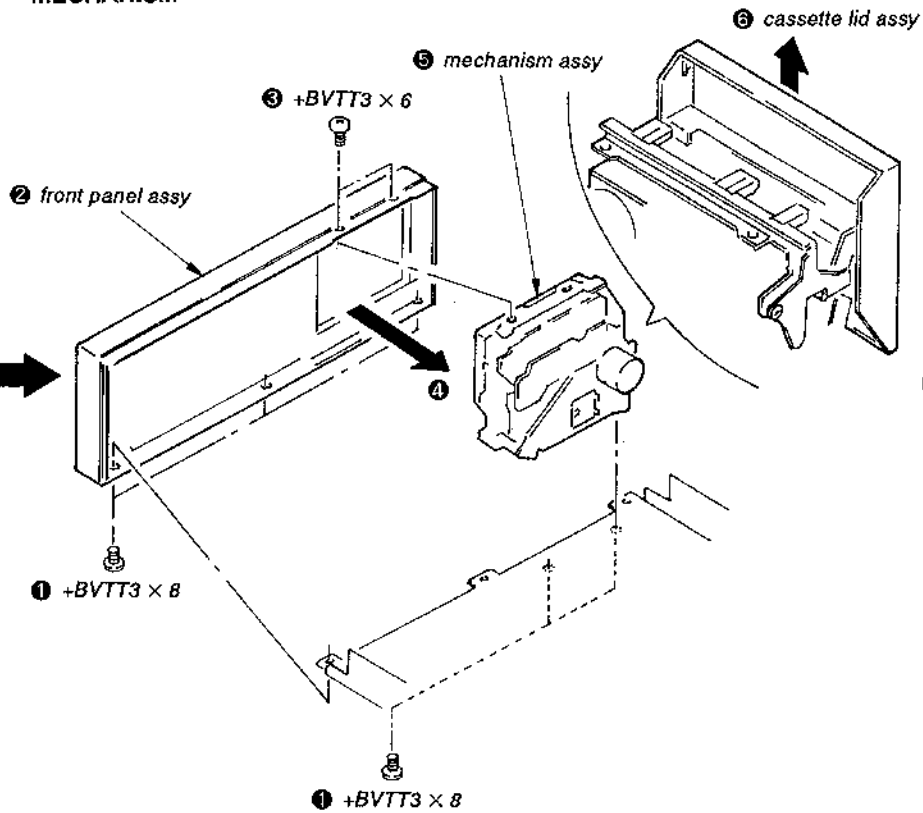

CASSETTE HOLDER

③ Push LEVER (LIFTER) in the direction of arrow and remove CASSETTE HOLDER.

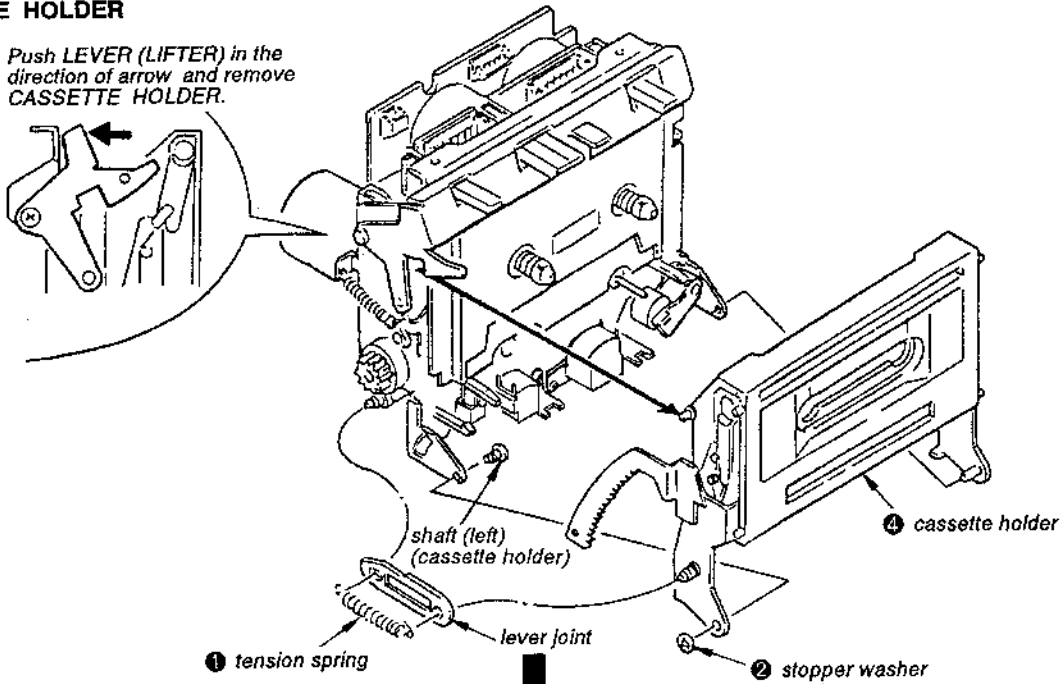

ORNAMENTAL PLATE

② Push LEVER (LIFTER) in the direction of arrow and remove ORNAMENTAL PLATE.

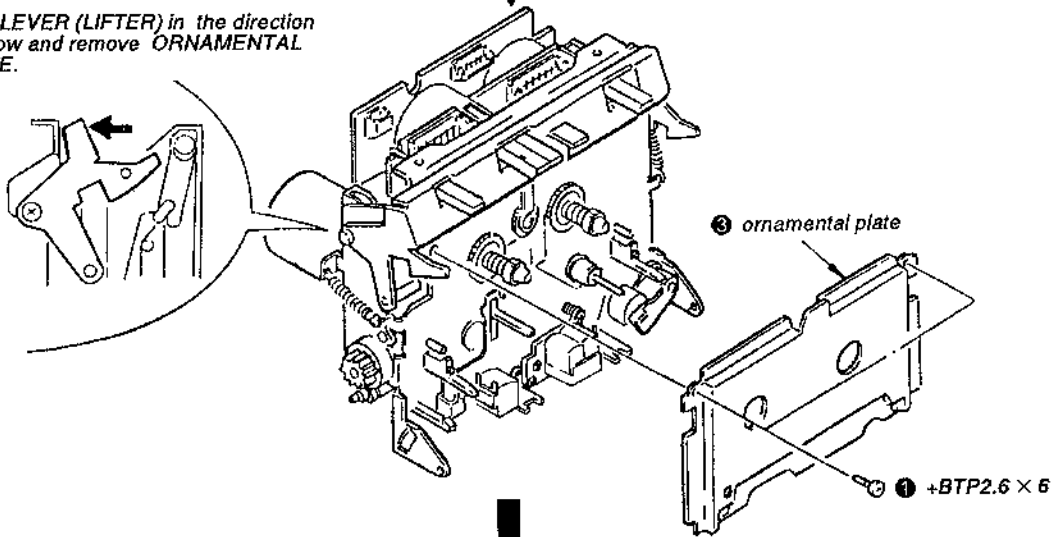

PINCH LEVER

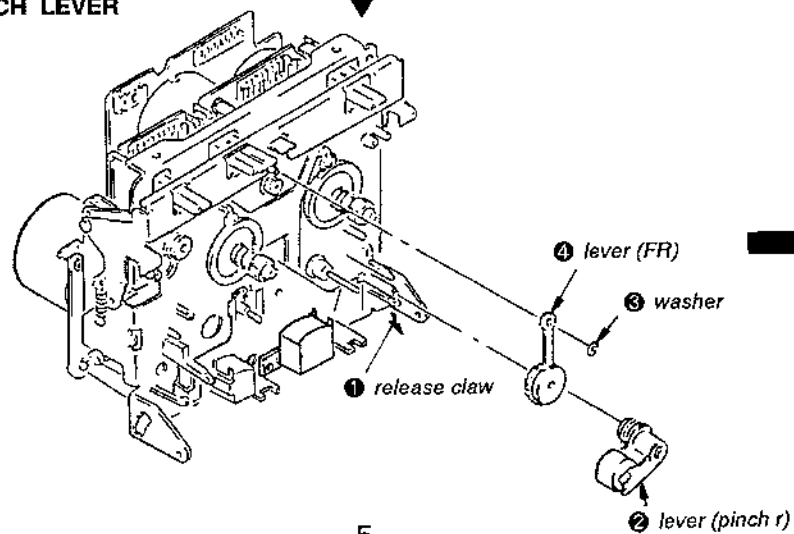

CAPSTAN MOTOR/FLYWHEEL

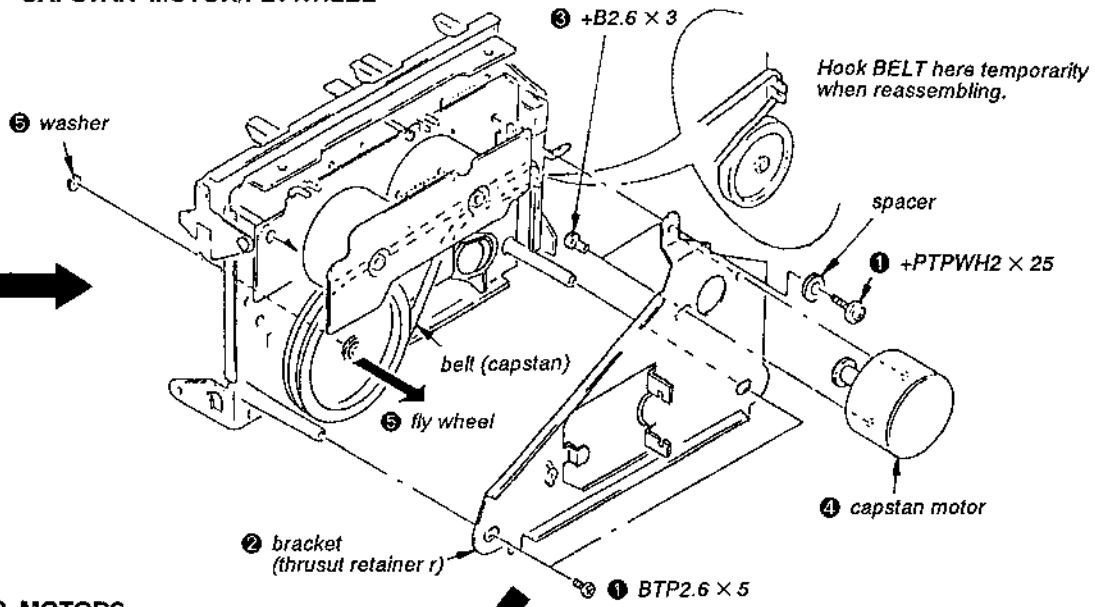

REEL AND MOTORS

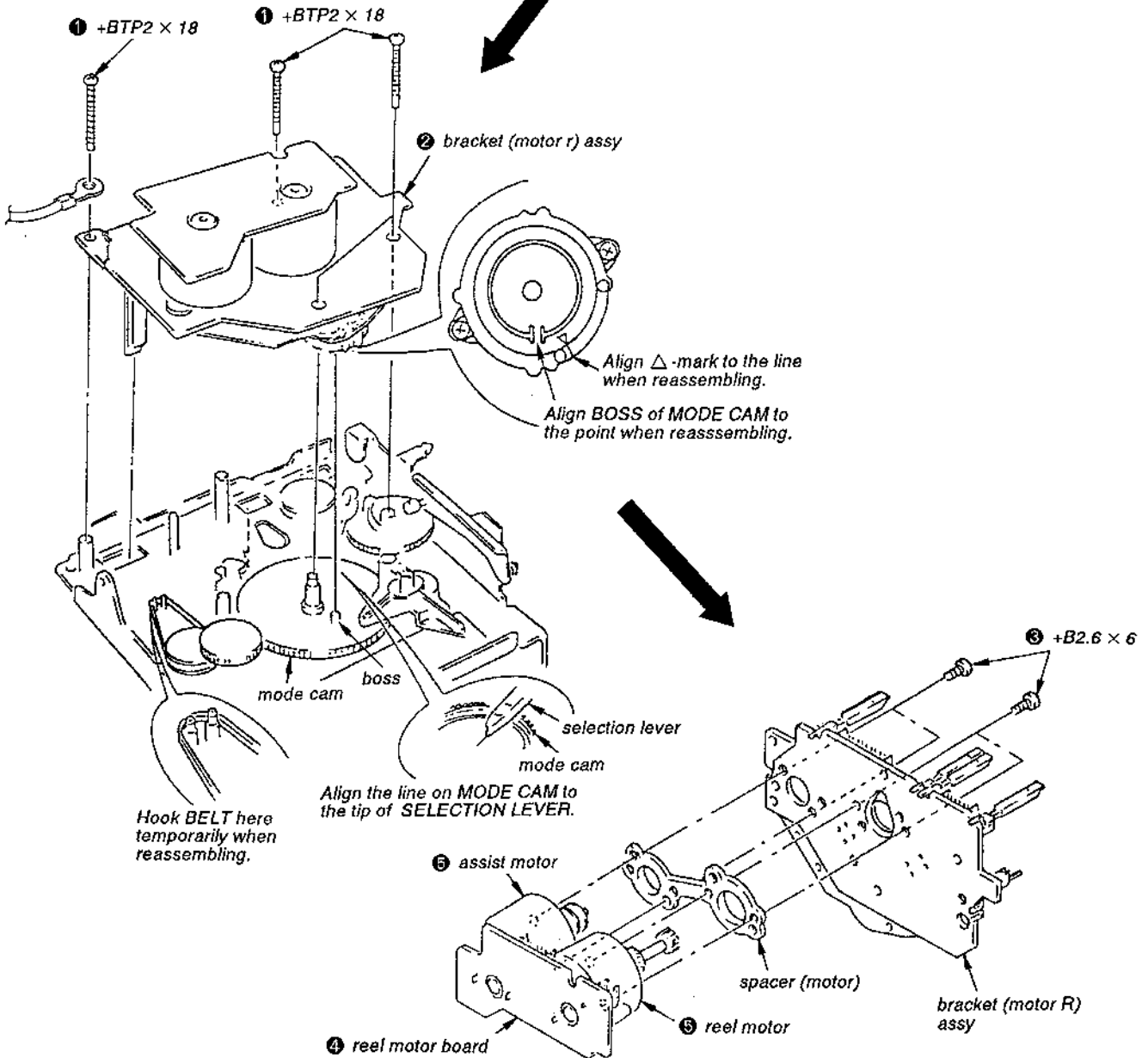

SECTION 3 MECHANICAL ADJUSTMENTS

PRECAUTION

- Clean the following parts with a denatured-alcohol-moistened swab:

record/playback head	pinch roller
erase head	rubber belts
capstan	idlers
- Demagnetize the record/playback head with a head demagnetizer. (Do not bring the head demagnetizer close to the erase head.)
- Do not use a magnetized screwdriver for the adjustments.
- After the adjustments, apply suitable locking compound to the parts adjusted.
- The adjustments should be performed with the rated power supply voltage unless otherwise noted.

Torque Measurement

Torque	Torque meter	Meter reading
Forward	CQ-102C	30—60g•cm (0.42—0.83oz•inch)
Forward back tension	CQ-102C	1—5g•cm (0.014—0.069oz•inch)
FF/REW	CQ-201B	70—120g•cm (0.97—1.68oz•inch)

SECTION 4 ELECTRICAL ADJUSTMENTS

- The adjustment should be performed in the publication (Be sure to make playback adjustment at first.)
- The adjustment and measurement should be performed for both L-CH and R-CH.
 - Switch position
DOLBY NR switch: OFF
TIMER switch: OFF
MPX FILTER switch: OFF
 - Standard record position
Deliver the standard input signal level to the input jack and set the REC LEVEL control to obtain the standard output signal level as follows.

—Record mode—

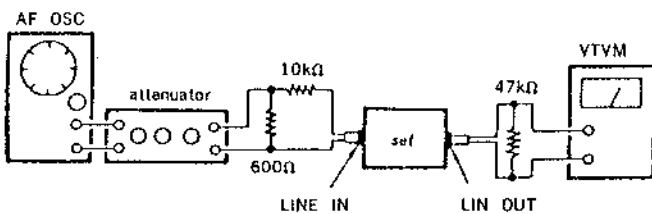

• Standard Input Level

Input terminal	LINE IN
source impedance	10kΩ
input signal level	0.25V (-10dB)

• Standard Output Level

Output terminal	LINE OUT
load impedance	47kΩ
output signal level	0.44V (-5dB)

TEST TAPE

Tape	Contents	Use
P-4-A100	10kHz, -10dB	Record/Playback Head Azimuth Adjustment
WS-48B	3kHz, 0dB	Tape Speed Adjustment
P-4-L300	315Hz, 0dB	Playback Level Adjustment

Record/Playback Head Azimuth Adjustment

procedure:

- Playback Mode

test tape
P-4-A100
(10kHz, -10dB)

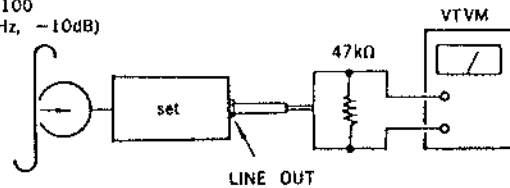

- Turn the adjustment screw for the maximum output levels. If these levels do not match, turn the adjustment screw until both of output levels match together within 1dB.

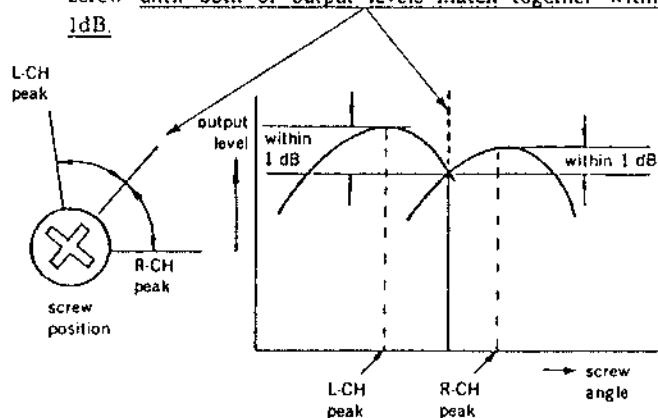

3. Phase Check

Playback mode

test tape
P-4-A100
(10kHz, -10dB)

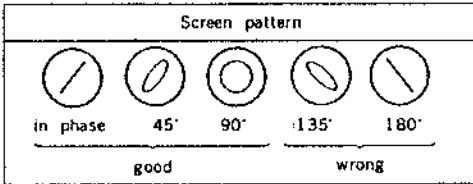
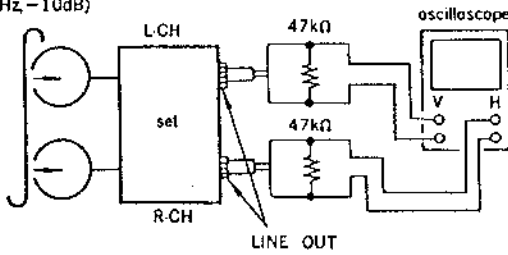

4. After the adjustment, lock the adjustment screw with suitable locking compound.

Adjustment Location: —record/playback head—

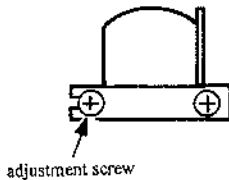

Tape Speed Adjustment

Procedure :

Playback Mode

test tape
WS-48B
(3kHz, 0dB)

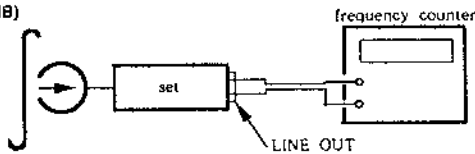

Specification :

Speed checker	Digital frequency counter
±0.5%	2,985—3,015Hz

Frequency difference between the beginning and the end of the tape should be within 0.5% (15Hz).

Adjustment Location :

adjustment the adjustable resistor of built in motor (adjustment by the insert to driver Speed in fastest that turn the clockwise.)

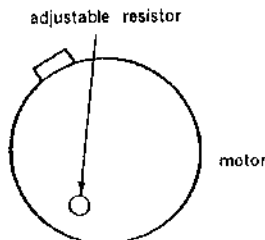

Playback Level Adjustment

Procedure :

Playback mode

test tape
P-4-L300
(315Hz, 0dB)

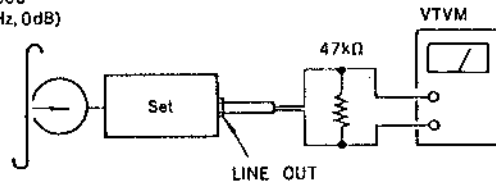

Specification :

Adjust RV101, 201 so that within adjustment level as follows.

LINE OUT level : 0.41 to 0.46V

(-5.5 to -4.5dB)

Level Difference between Channels : Within 0.5dB

Confirm the LINE OUT level does not change in playback mode while changing the mode from playback to stop several times.

Bias Consumption Current Adjustment

Bias Consumption current adjustment is necessary to check before record bias adjustment.

The bias consumption current is wrong, record bias adjustment should do over again.

1. Connect CNE503 with digital volt meter.
2. Adjust T101, 201 to minimum reading of digital volt meter.

Record Mode
LINE IN
(no signal)

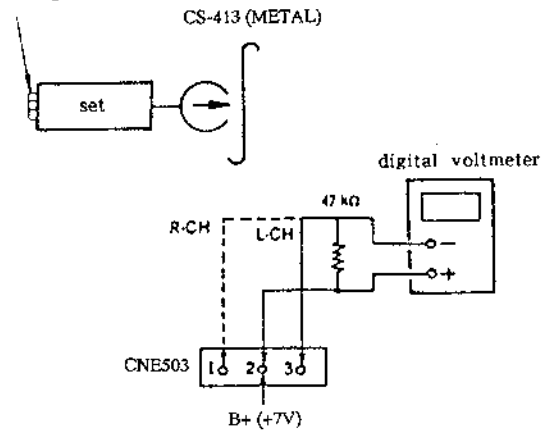

Adjust T101, 201 so That the minimum of digital volt meter.

Record Bias Adjustment

Setting :

REC LEVEL knob shall be the specified record position.

Procedure :

1. Record Mode

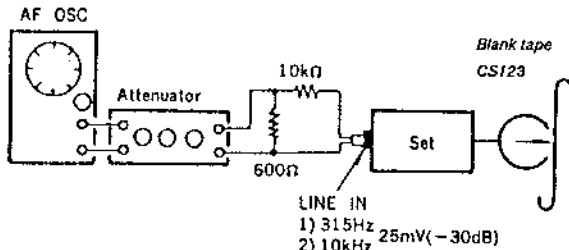

2. Playback Mode

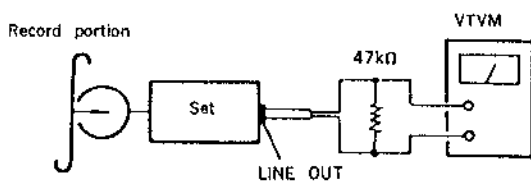

Adjust RV103, 203 so that playback output of 10kHz is 0 ± 0.5 dB relative to that of 315Hz.

Record Level Adjustment

Setting :

REC LEVEL knob shall be at the specified record position.

Procedure :

1. Record Mode

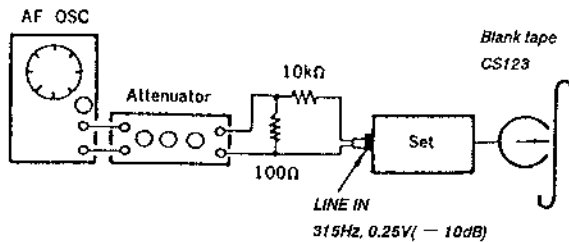

2. Playback Mode

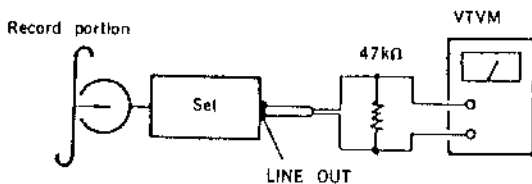

Specification:

Adjust RV102, 202 so that with in adjustment level as follows.

LINE OUT Level: CS-123
0.41 to 0.46V
(-5.5 to -4.5dB)

Adjustment Location : main board

【 MAIN BOARD 】

- COMPONENT SIDE -

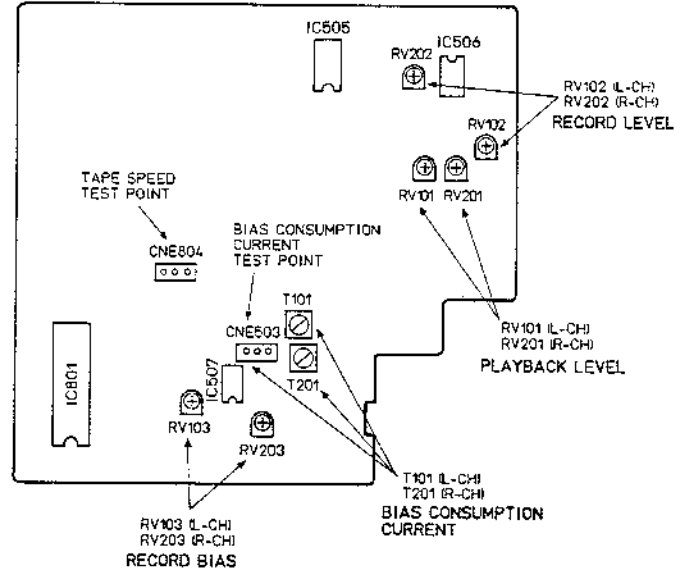

SECTION 5 DIAGRAMS

• Circuit Boards Location

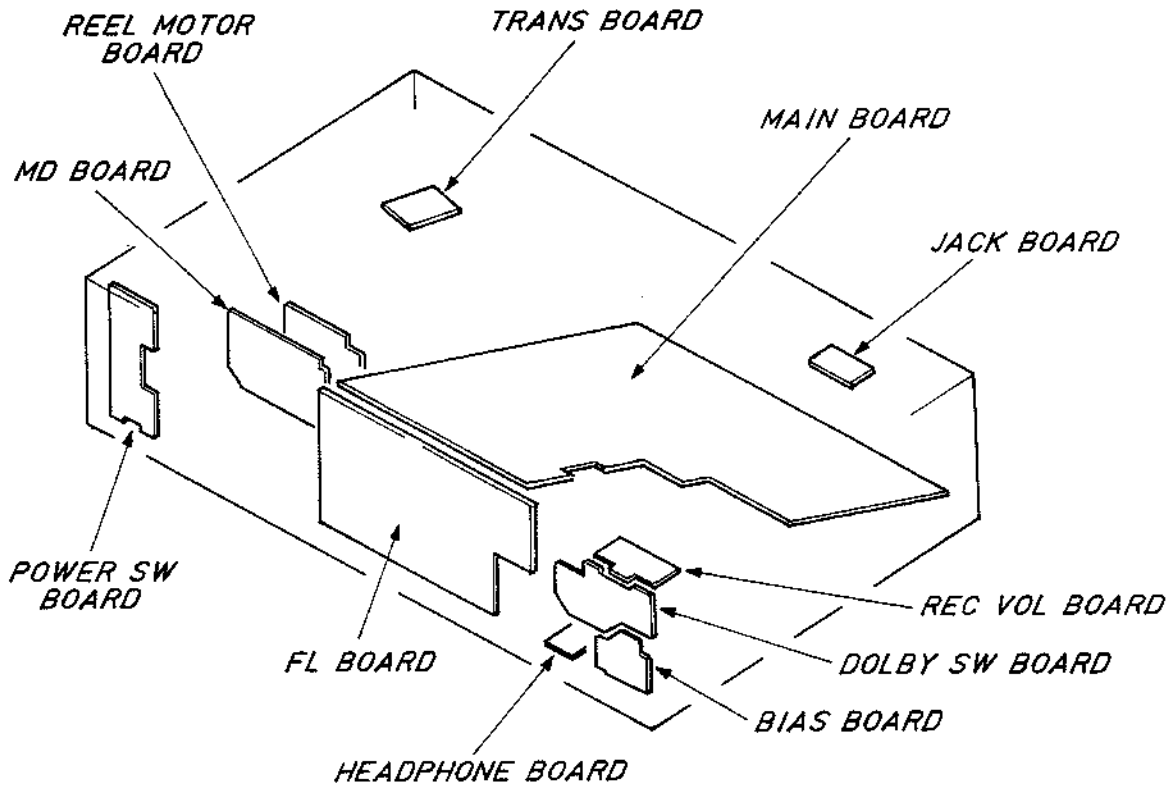

• Semiconductor Lead Layouts

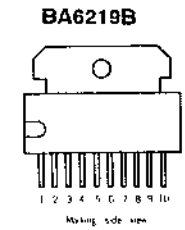

2SA1175-HFE
2SA1317-STU
2SD1020-HFE

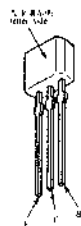

HZS6A1L
HZS6C3L
UZL-7H1
UZL-12H1
1S5202-1

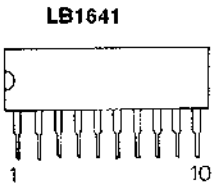
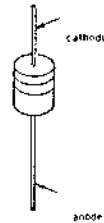

2SA1409-TP
2SC945-P
2SB1116A-L

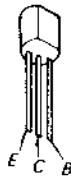

10E2N

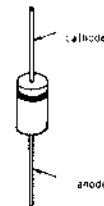

DTA114ES
DTC114ES
DTC143TS
2SC2603-EF
2SD2144S

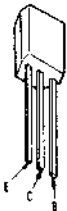

2SB1187-EF
2SD1761-EF

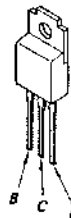

GP2S22B

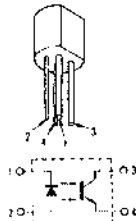

5-1. PRINTED WIRING BOARDS

• See page 10 for Circuit boards Location and Semiconductor Lead Layouts.

Note on Printed Wiring Board:

- : parts extracted from the component side.
- : parts mounted on the conductor side.
- : indicates side identified with part number.

• Semiconductor Location

Ref. No.	Location	Ref. No.	Location
D101	H-11	IC803	E-12
D201	G-11	IC804	E-11
D501	G-13	IC851	G-18
D502	I-13	IC1001	I-3
D503	I-14	IC1002	I-4
D504	K-9	Q101	J-11
D505	K-9	Q102	G-10
D506	G-15	Q103	I-9
D509	G-13	Q104	J-10
D510	I-10	Q201	J-11
D511	K-11	Q202	H-10
D512	K-11	Q203	I-8
D513	H-13	Q204	J-9
D701	C-12	Q501	G-13
D702	C-12	Q502	F-13
D703	C-12	Q503	G-9
D704	C-12	Q504	G-8
D706	B-11	Q505	G-8
D707	B-10	Q506	F-13
D708	F-10	Q511	K-8
D709	E-8	Q512	K-9
D710	B-8	Q513	K-8
D711	D-10	Q515	E-14
D712	C-12	Q516	E-15
D713	C-12	Q518	E-14
D714	B-12	Q519	H-15
D715	B-12	Q520	H-15
D716	B-12	Q701	E-10
D717	B-10	Q702	D-9
D719	C-8	Q703	D-9
D720	C-8	Q704	C-8
D721	C-10	Q705	B-8
D722	B-11	Q706	C-10
D723	C-10	Q707	C-10
D724	D-11	Q708	E-10
D801	E-13	Q709	E-9
D802	D-13	Q710	C-9
D803	F-13	Q711	B-8
D804	F-12	Q712	C-10
D805	F-12	Q801	D-14
D808	B-6	Q802	E-14
D809	B-6	Q803	D-14
D811	E-18	Q804	D-14
D812	E-18	Q805	F-12
D813	G-16	Q806	E-10
D814	B-6	Q807	E-16
D815	F-16	Q808	D-16
D818	C-16	Q809	C-13
D819	C-16	Q810	C-13
D820	B-11	Q811	G-16
D1051	G-4	Q812	B-13
IC501	I-12	Q814	F-18
IC502	F-11	Q815	F-18
IC503	G-11	Q851	E-16
IC504	G-12	Q853	E-16
IC505	H-9	Q854	E-16
IC506	J-9	Q855	F-16
IC507	F-14	Q856	F-16
IC701	F-9	Q857	G-16
IC801	C-14	Q858	H-15
IC802	E-13		

FLT851 FLUORESCENT DISPLAY TUBE

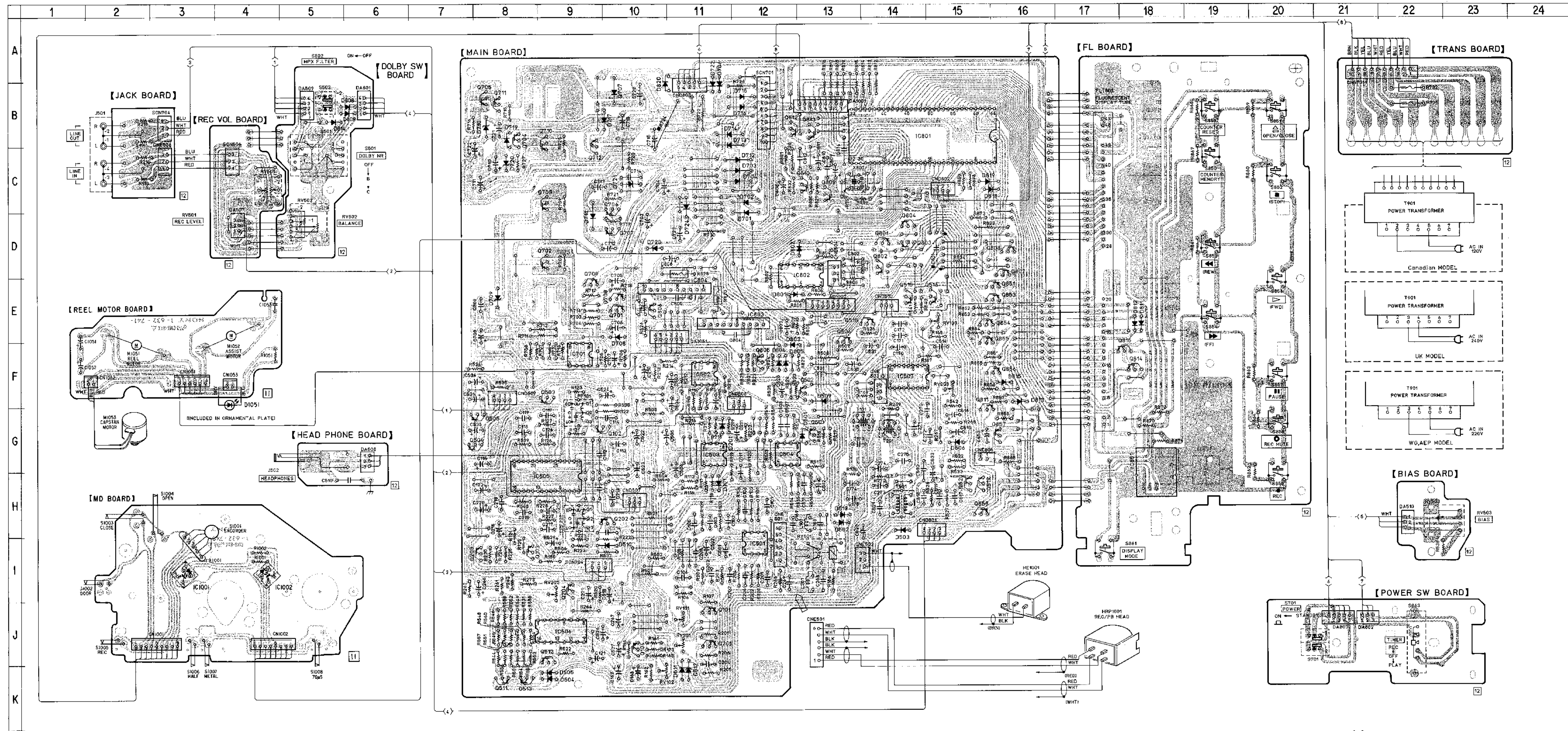
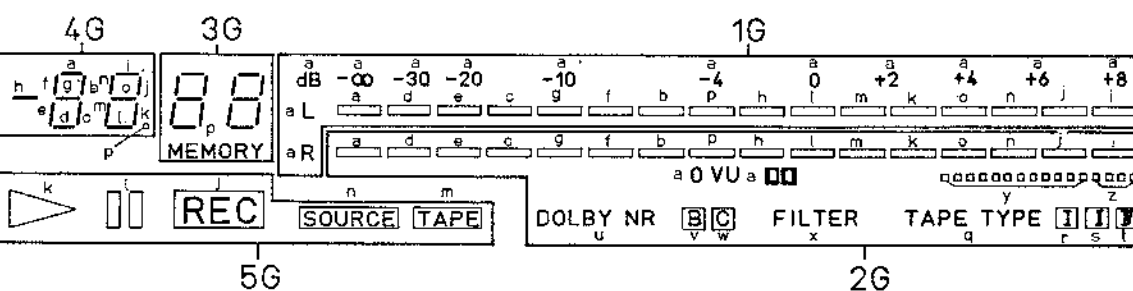

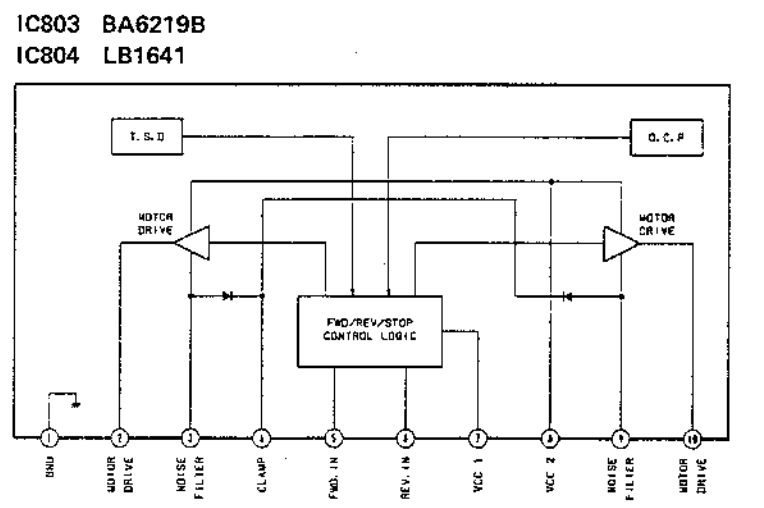
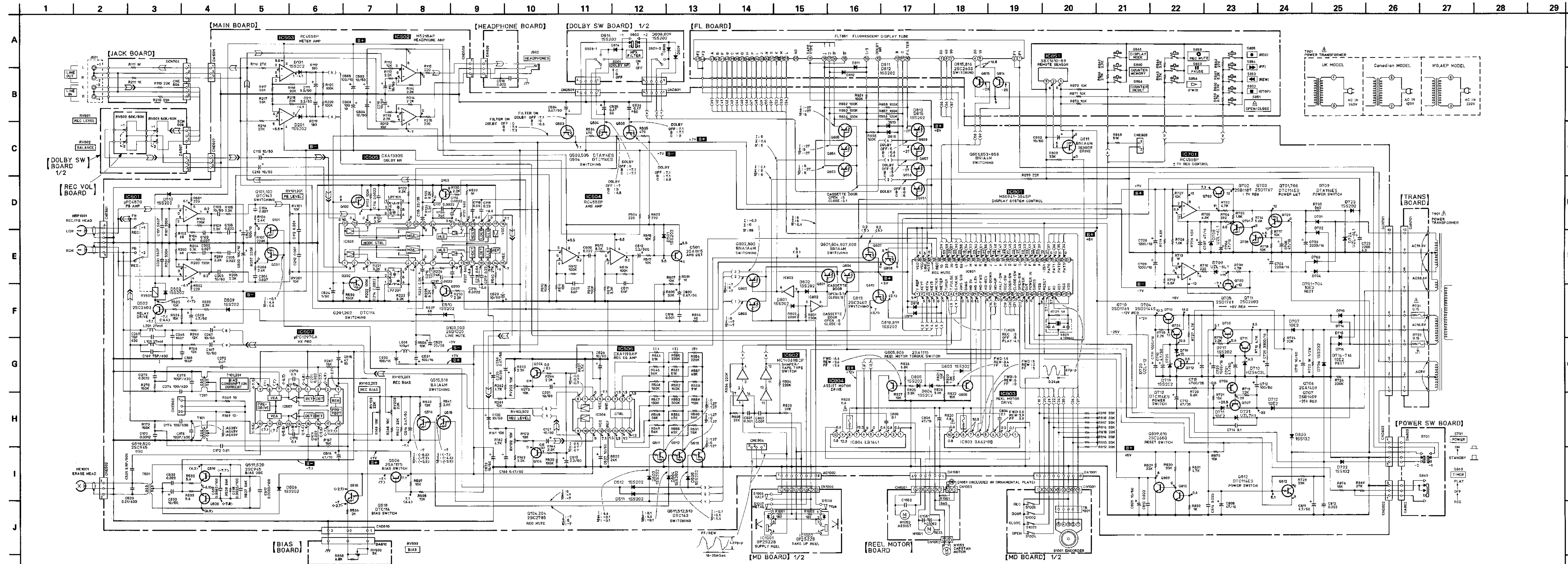

Note on Schematic Diagram:

- All capacitors are in μF unless otherwise noted. pF: pF; μF : μF and tantalums.
- All resistors are in Ω and $\frac{1}{2} W$ or less unless otherwise specified.
- Δ : internal component.
- ∇ : fusible resistor.

Note:
The components identified by mark Δ or dotted line with mark ∇ are critical for safety. Replace only with part number specified.

Note:
Les composants identifiés par une marque Δ sont critiques pour la sécurité. Ne les remplacer que par une pièce portant le numéro spécifié.

- $B+$: B+ Line.
- $B-$: B- Line.
- ∇ : adjustment for repair.
- Voltagés and waveforms are dc with respect to ground under no-signal conditions.
- no mark: PLAY
- <: REC
- I: NORMAL TAPE
- II: C-02 TAPE
- IV: METAL TAPE

• Voltages are taken with a VOM (impedance 10 M Ω). Voltage variations may be noted due to normal production tolerances.

• Waveforms are taken with an oscilloscope. Voltage variations may be noted due to normal production tolerances.

• Signal path.
 ∇ : PB
 ∇ : REC

SECTION 6 EXPLODED VIEWS

NOTE:

- The mechanical parts with no reference number in the exploded views are not supplied.
- The construction parts of an assembled part are indicated with a collation number in the remark column.
- Items marked "*" are not stocked since they are seldom required for routine service. Some delay should be anticipated when ordering these items.

- Due to standardization, parts with part number suffix -XX and -X may be different from the parts specified in the components used on the set.

- Color Indication of Appearance Parts
Example:

(RED) ... KNOB, BALANCE (WHITE)



Cabinet's Color



Parts' Color

- WG: West Germany model

The components identified by mark or dotted line with mark are critical for safety. Replace only with part number specified.

Les composants identifiés par une marque sont critiques pour la sécurité. Ne les remplacer que par une pièce portant le numéro spécifié.

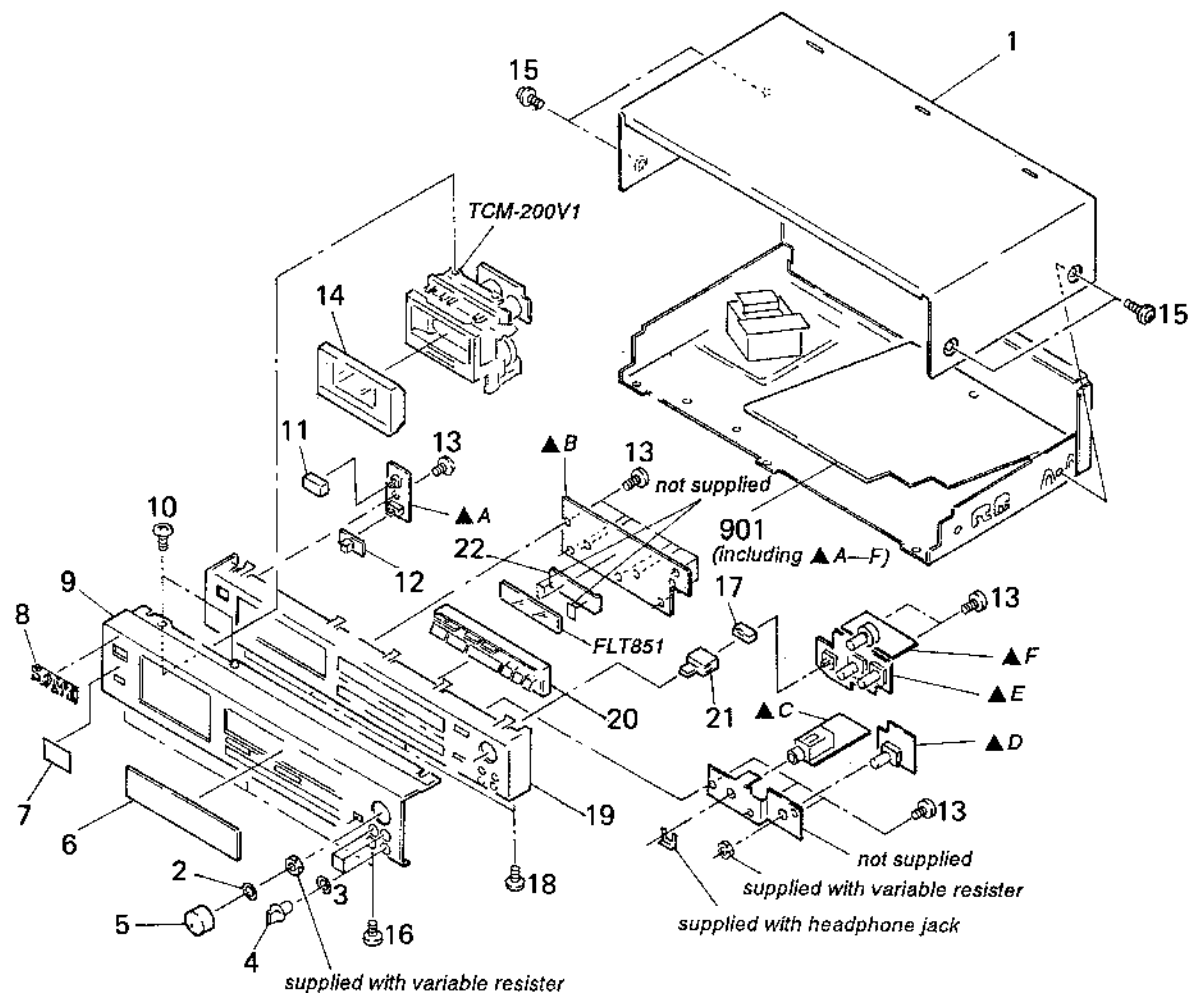
(1) CABINET SECTION

No.	Part No.	Description	Remarks	No.	Part No.	Description	Remarks
1	3-332-578-61	CASE		13	4-928-635-01	SCREW, +BV (2.6X8) TAPPING	
2	3-350-440-01	SPRING		14	X-3304-977-1	LID ASSY, CASSETTE	
3	3-356-957-01	SPRING		15	3-704-366-01	SCREW (CASE) (M3X8)	
4	3-350-495-01	KNOB (VOL)		16	7-685-534-19	SCREW +BTP 2.6X8 TYPE2 N-S	
5	X-3304-973-1	KNOB (R) ASSY		17	4-864-307-00	RING	
6	3-350-838-21	WINDOW (M)		18	7-682-548-09	SCREW +BVTT 3X8 (S)	
7	*3-703-710-41	STICKER, SONY SYMBOL (12)		19	3-350-842-11	PANEL (BASE)	
8	4-908-848-01	EMBLEM, SONY		20	3-356-975-11	BUTTON	
9	3-356-977-51	(AEP,UK,WG)...PANEL, FRONT		21	3-304-926-11	KNOB (A), PUSH	
	3-356-977-61	(Canadian)...PANEL, FRONT		22	*3-350-824-01	HOLDER (FL)	
10	7-682-547-04	SCREW +BVTT 3X6 (S)		901	*A-2006-272-A	MOUNTED PCB, MAIN	
11	4-922-921-01	BUTTON (POWER)					
12	4-931-421-11	KNOB (T & S)					

(2) PANEL SECTION

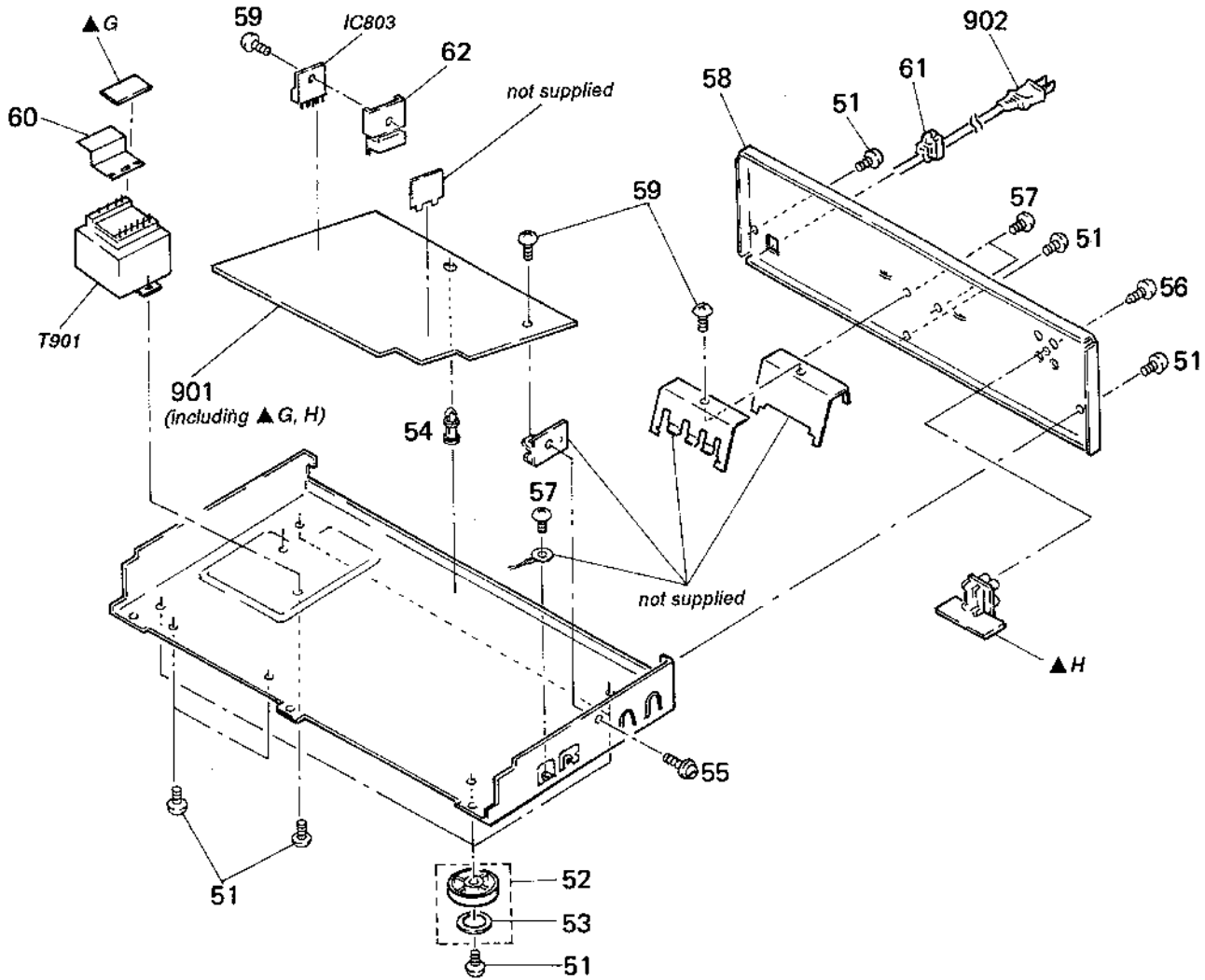

No.	Part No.	Description	Remarks	No.	Part No.	Description	Remarks
51	7-682-548-09	SCREW +BVTT 3X8 (S)		61	*3-703-244-00	(AEP,UK,WG)....BUSHING (2104), CORD	
52	X-3304-938-2	FOOT ASSY			*3-703-571-12	(Canadian)...BUSHING (S)(4516), CORD	
53	4-923-836-11	CUSHION		62	*3-356-925-01	HEAT SINK	
54	*3-669-610-00	SPACER		902	▲.1-551-506-XX	(Canadian)...CORD, POWER	
55	3-704-366-31	SCREW (CASE) (M3X6)			▲.1-555-795-00	(AEP,WG)....CORD, POWER	
56	7-621-849-00	SCREW, TAPPING			▲.1-556-035-00	(UK).....CORD, POWER	
57	7-682-547-09	SCREW +BVTT 3X6 (S)		T901	▲.1-450-099-11	(AEP,UK,WG)...TRANSFORMER, POWER	
58	*3-356-980-21	(UK).....PANEL, BACK		T901	▲.1-450-100-11	(Canadian)...TRANSFORMER, POWER	
	*3-356-980-11	(AEP,UK)....PANEL, BACK					
	*3-356-980-31	(Canadian)...PANEL, BACK					
59	7-682-547-04	SCREW +BVTT 3X6 (S)					
60	*3-337-136-11	COVER, TRANSFORMER SAFETY					

<p>Note: The components identified by mark ▲ or dotted line with mark ▲ are critical for safety. Replace only with part number specified.</p>	<p>Note: Les composants identifiés par une marque ▲ sont critiques pour la sécurité. Ne les remplacer que par une pièce portant le numéro spécifié.</p>
--	--

(3) MECHANISM SECTION ① (TCM-200V1)

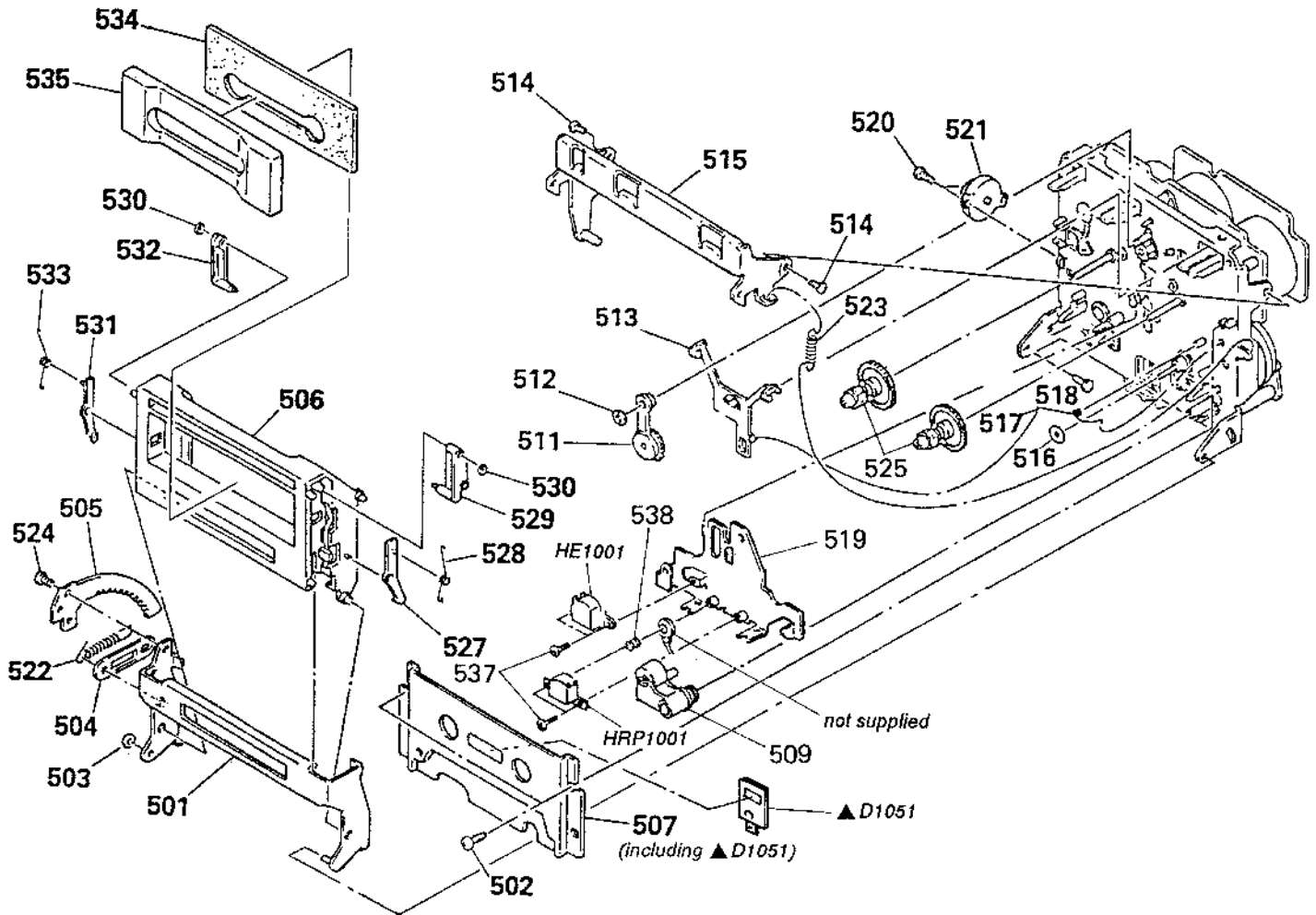

No.	Part No.	Description	Remarks	No.	Part No.	Description	Remarks
501	X-3356-612-1	HOLDER (B) ASSY, CASSETTE		521	3-712-786-01	DAMPER, OIL	
502	7-685-133-19	SCREW +BTP 2.6X6 TYPE2 N-S		522	3-356-626-01	SPRING, TENSION	
503	3-558-708-21	WASHER, STOPPER		523	3-356-625-01	SPRING, TENSION	
504	*3-356-717-01	LEVER (JOINT)		524	7-621-775-10	SCREW +B 2.6X4	
505	3-356-708-01	GEAR (SOFT EJECT)		525	X-3356-627-1	GEAR ASSY	
506	X-3356-611-1	HOLDER (A) ASSY, CASSETTE		527	3-356-930-01	LEVER (RA)	
507	X-3356-613-1	PLATE ASSY, ORNAMENTAL		528	3-356-926-01	SPRING (RIGHT), TORSION	
509	X-3356-649-1	LEVER (PINCH LEVER T) ASSY		529	3-356-931-01	LEVER (RB)	
511	X-3356-641-1	LEVER (FR2) ASSY		530	3-356-946-01	BUSHING	
512	3-669-465-00	WASHER (1.5), STOPPER		531	3-356-932-01	LEVER (LA)	
513	3-356-614-01	SLIDER (BRAKE)		532	3-356-933-01	LEVER (LB)	
514	3-356-601-11	SCREW, STEP		533	3-356-927-01	SPRING (LEFT), TORSION	
515	*X-3356-608-1	LEVER (LIFTER) ASSY		534	3-356-731-01	ABSORBENT, VIBRATION	
516	3-356-713-01	WASHER		535	3-356-928-01	PLATE (A), ORNAMENTAL	
517	3-356-619-01	SPRING (B), TORSION		537	7-621-772-20	SCREW +B 2X5	
518	3-356-710-01	SHAFT (LEFT) (CASSETTE HOLDER)		538	3-362-238-01	SPRING (VH), COMPRESSION	
519	X-3356-647-1	SLIDER (HEAD CHASSIS V1) ASSY		D1051	8-719-980-85	DIODE SLF-325C	
520	7-621-255-20	SCREW +BVTT 2X4 (S)		HE1001	1-543-535-11	HEAD, MAGNETIC (ERASE)	
				HRP1001	1-543-537-11	HEAD, MAGNETIC (REC/PB)	

(4) MECHANISM SECTION ② (TCM-200V1)

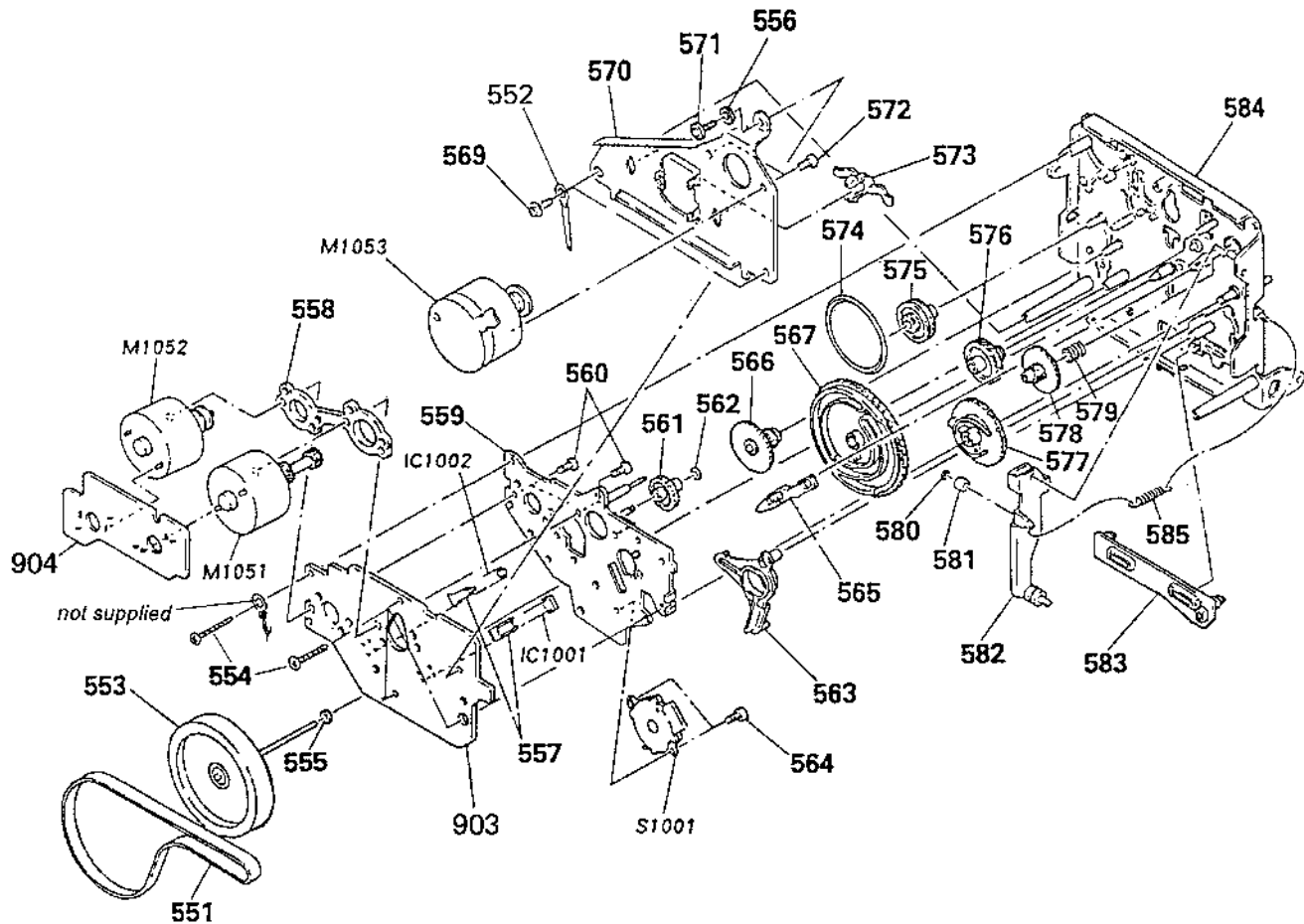

No.	Part No.	Description	Remarks	No.	Part No.	Description	Remarks
551	3-356-744-01	BELT (CAPSTAN V)		572	7-621-775-00	SCREW +B 2.6X3	
552	*3-701-822-00	HOLDER, WIRE		573	3-575-321-00	RETAINER, THRUST, CAPSTAN	
553	X-3356-642-1	FLYWHEEL (R FWD) ASSY		574	3-356-603-01	BELT (MODE)	
554	3-355-801-01	SCREW (BTP 2X18)		575	3-356-607-01	PULLEY (MODE)	
555	3-356-705-01	WASHER (CAPSTAN)		576	3-356-703-01	GEAR (COMMUNICATION C)	
556	*3-356-718-01	SPACER (THRUST RETAINER R)		577	3-356-616-01	GEAR (LOADING CAM)	
557	3-356-631-01	HOLDER (SENSOR)		578	3-356-609-01	GEAR (LOADING)	
558	*3-356-628-01	SPACER (MOTOR)		579	3-356-605-01	SPRING, COMPRESSION	
559	*X-3356-602-4	BRACKET (MOTOR R) ASSY		580	3-558-708-11	WASHER, STOPPER	
560	7-621-773-95	SCREW +B 2.6X6		581	3-356-630-01	ROLLER (LOADING)	
561	3-356-702-01	GEAR (COMMUNICATION B)		582	*X-3356-606-1	LEVER (LOADING) ASSY	
562	3-669-465-00	WASHER (1.5), STOPPER		583	3-356-653-01	SLIDER (PAUSE)	
563	3-356-613-01	LEVER (MODE)		584	X-3356-644-1	CHASSIS COMPLETE ASSY, MECH	
564	7-621-772-20	SCREW +B 2X5		585	3-356-624-01	SPRING, TENSION	
565	3-356-617-01	LEVER (SELECTION)		903	*1-632-740-11	PC BOARD, MD	
566	3-356-606-01	GEAR (MODE)		904	*1-632-741-11	PC BOARD, REAL MOTOR	
567	3-356-747-01	GEAR (MODE CAM C)		M1051	X-3356-638-1	MOTOR (REEL R) ASSY	
569	7-685-132-19	SCREW +BTP 2.6X5 TYPE2 N-S		M1052	X-3356-604-1	MOTOR (ASSIST) ASSY	
570	*3-356-629-01	BRACKET (THRUST RETAINER R)		M1053	X-3356-646-1	MOTOR (CAPSTAN V1) ASSY	
571	3-356-707-01	SCREW (+PTPHW 2X25)		S1001	1-466-238-11	ENCODER, ROTARY	

SECTION 7 ELECTRICAL PARTS LIST

NOTE:

- Due to standardization, replacements in the parts list may be different from the parts specified in the diagrams or the components used on the set.
- Items marked "★" are not stocked since they are seldom required for routine service. Some delay should be anticipated when ordering these items.
- If there are two or more same circuits in a set such as a stereophonic machine, only typical circuit parts may be indicated and capacitors and resistors in other same circuits may be omitted.

CAPACITORS:

MF: μ F, PF: μ μ F.

RESISTORS

- All resistors are in ohms.
- F: nonflammable

COILS

- MMH: mH, UH: μ H

SEMICONDUCTORS

In each case, U: μ , for example:

UA...: μ A..., UPA...: μ PA...,

UPC...: μ PC, UPD...: μ PD...

The components identified by mark Δ or dotted line with mark Δ are critical for safety. Replace only with part number specified.

Les composants identifiés par une marque Δ sont critiques pour la sécurité. Ne les remplacer que par une pièce portant le numéro spécifié.

- WG: West Germany model

Ref.No.	Part No.	Description					Ref.No.	Part No.	Description					
901	*A-2006-272-A	MOUNTED PCB, MAIN					C217	1-130-475-00	MYLAR	0.0022MF	5%	50V		
902	Δ 1-551-506-XX	(Canadian)...CORD, POWER					C218	1-136-174-00	FILM	0.56MF	5%	50V		
	Δ 1-555-795-00	(AEP,WG).....CORD, POWER					C219	1-136-171-00	FILM	0.33MF	5%	50V		
	Δ 1-556-035-00	(UK).....CORD, POWER					C220	1-123-875-11	ELECT	10MF	20%	50V		
903	*1-632-740-11	PC BOARD, MD					C221	1-123-875-11	ELECT	10MF	20%	50V		
904	*1-632-741-11	PC BOARD, REAL MOTOR					C266	1-124-902-00	ELECT	0.47MF	20%	50V		
C101	1-130-468-00	MYLAR	560PF	5%	50V	C267	1-123-875-11	ELECT	10MF	20%	50V			
C102	1-130-488-00	MYLAR	0.027MF	5%	50V	C268	1-162-284-31	CERAMIC	150PF	10%	50V			
C103	1-124-657-00	ELECT	10MF	20%	50V	C269	1-136-273-91	FILM	75PF	5%	630V			
C104	1-130-488-00	MYLAR	0.027MF	5%	50V	C270	1-136-165-00	FILM	0.1MF	5%	50V			
C105	1-161-494-00	CERAMIC	0.022MF	25V		C271	1-136-157-00	FILM	0.022MF	5%	50V			
C110	1-123-875-11	ELECT	10MF	20%	50V	C272	1-136-153-00	FILM	0.01MF	5%	50V			
C111	1-123-382-00	ELECT	3.3MF	20%	50V	C273	1-130-472-00	MYLAR	0.0012MF	5%	50V			
C112	1-162-294-31	CERAMIC	0.001MF	10%	50V	C274	1-136-433-11	FILM	100PF	5%	630V			
C113	1-123-875-11	ELECT	10MF	20%	50V	C275	1-136-433-11	FILM	100PF	5%	630V			
C114	1-161-375-00	CERAMIC	0.0022MF	20%	16V	C501	1-124-443-00	ELECT	100MF	20%	10V			
C115	1-126-233-11	ELECT	22MF	20%	25V	C502	1-124-443-00	ELECT	100MF	20%	10V			
C116	1-130-475-00	MYLAR	0.0022MF	5%	50V	C503	1-123-875-11	ELECT	10MF	20%	50V			
C117	1-130-475-00	MYLAR	0.0022MF	5%	50V	C504	1-123-875-11	ELECT	10MF	20%	50V			
C118	1-136-174-00	FILM	0.56MF	5%	50V	C505	1-124-443-00	ELECT	100MF	20%	10V			
C119	1-136-171-00	FILM	0.33MF	5%	50V	C506	1-124-443-00	ELECT	100MF	20%	10V			
C120	1-123-875-11	ELECT	10MF	20%	50V	C507	1-162-217-31	CERAMIC	56PF	5%	50V			
C121	1-123-875-11	ELECT	10MF	20%	50V	C508	1-161-494-00	CERAMIC	0.022MF	25V				
C166	1-124-902-00	ELECT	0.47MF	20%	50V	C510	1-161-494-00	CERAMIC	0.022MF	30%	25V			
C167	1-123-875-11	ELECT	10MF	20%	50V	C511	1-162-217-31	CERAMIC	56PF	5%	50V			
C168	1-162-284-31	CERAMIC	150PF	10%	50V	C512	1-124-925-11	ELECT	2.2MF	20%	50V			
C169	1-136-273-91	FILM	75PF	5%	630V	C513	1-124-925-11	ELECT	2.2MF	20%	50V			
C170	1-136-165-00	FILM	0.1MF	5%	50V	C514	1-124-477-11	ELECT	47MF	20%	16V			
C171	1-136-157-00	FILM	0.022MF	5%	50V	C515	1-124-446-11	ELECT	47MF	20%	10V			
C172	1-136-153-00	FILM	0.01MF	5%	50V	C516	1-124-902-00	ELECT	0.47MF	20%	50V			
C173	1-130-472-00	MYLAR	0.0012MF	5%	50V	C517	1-136-593-11	FILM	0.0033MF	5%	100V			
C174	1-136-433-11	FILM	100PF	5%	630V	C518	1-136-593-11	FILM	0.0033MF	5%	100V			
C175	1-136-433-11	FILM	100PF	5%	630V	C519	1-130-848-00	FILM	0.0082MF	5%	100V			
C201	1-130-468-00	MYLAR	560PF	5%	50V	C520	1-136-601-11	FILM	0.01MF	5%	630V			
C202	1-130-488-00	MYLAR	0.027MF	5%	50V	C521	1-107-045-00	MICA	3.9PF	0.5PF	500V			
C203	1-124-657-00	ELECT	10MF	20%	50V	C522	1-123-875-11	ELECT	10MF	20%	50V			
C204	1-130-488-00	MYLAR	0.027MF	5%	50V	C523	1-123-875-11	ELECT	10MF	20%	50V			
C205	1-161-494-00	CERAMIC	0.022MF	25V		C524	1-124-791-11	ELECT	1MF	20%	50V			
C210	1-123-875-11	ELECT	10MF	20%	50V	C526	1-123-875-11	ELECT	10MF	20%	50V			
C211	1-123-382-00	ELECT	3.3MF	20%	50V	C527	1-123-875-11	ELECT	10MF	20%	50V			
C212	1-162-294-31	CERAMIC	0.001MF	10%	50V	C528	1-124-927-11	ELECT	4.7MF	20%	50V			
C213	1-123-875-11	ELECT	10MF	20%	50V	C529	1-126-233-11	ELECT	22MF	20%	25V			
C214	1-161-375-00	CERAMIC	0.0022MF	20%	16V	C530	1-126-101-11	ELECT	100MF	20%	16V			
C215	1-126-233-11	ELECT	22MF	20%	25V	C531	1-126-101-11	ELECT	100MF	20%	16V			
C216	1-130-475-00	MYLAR	0.0022MF	5%	50V	C532	1-161-494-00	CERAMIC	0.022MF	25V				

Ref.No.	Part No.	Description				Ref.No.	Part No.	Description
C533	1-123-875-11	ELECT	10MF	20%	50V	D101	8-719-107-94	DIODE 1SS202-1
C534	1-124-902-00	ELECT	0.47MF	20%	50V	D201	8-719-107-94	DIODE 1SS202-1
C535	1-124-902-00	ELECT	0.47MF	20%	50V	D501	8-719-107-94	DIODE 1SS202-1
C536	1-124-902-00	ELECT	0.47MF	20%	50V	D502	8-719-107-94	DIODE 1SS202-1
C703	1-124-556-11	ELECT	2200MF	20%	16V	D503	8-719-107-94	DIODE 1SS202-1
C704	1-124-556-11	ELECT	2200MF	20%	16V	D504	8-719-107-94	DIODE 1SS202-1
C705	1-124-477-11	ELECT	47MF	20%	16V	D505	8-719-107-94	DIODE 1SS202-1
C706	1-124-477-11	ELECT	47MF	20%	16V	D506	8-719-107-94	DIODE 1SS202-1
C707	1-124-477-11	ELECT	47MF	20%	16V	D509	8-719-107-94	DIODE 1SS202-1
C708	1-124-473-11	ELECT	1000MF	20%	10V	D510	8-719-107-94	DIODE 1SS202-1
C709	1-124-473-11	ELECT	1000MF	20%	10V	D511	8-719-107-94	DIODE 1SS202-1
C710	1-124-927-11	ELECT	4.7MF	20%	50V	D512	8-719-107-94	DIODE 1SS202-1
C711	1-124-360-00	ELECT	1000MF	20%	16V	D513	8-719-107-94	DIODE 1SS202-1
C712	1-124-122-11	ELECT	100MF	20%	50V	D701	8-719-200-77	DIODE 10E2N
C713	1-124-910-11	ELECT	47MF	20%	35V	D702	8-719-200-77	DIODE 10E2N
C714	1-164-159-11	CERAMIC	0.1MF		50V	D703	8-719-200-77	DIODE 10E2N
C715	1-124-564-11	ELECT	4700MF	20%	25V	D704	8-719-200-77	DIODE 10E2N
C718	1-123-875-11	ELECT	10MF	20%	50V	D706	8-719-107-94	DIODE 1SS202-1
C720	1-124-887-00	ELECT	3300MF	20%	16V	D707	8-719-200-77	DIODE 10E2N
C721	1-124-927-11	ELECT	4.7MF	20%	50V	D708	8-719-933-33	DIODE HZS6A1L
C722	1-124-473-11	ELECT	1000MF	20%	10V	D709	8-719-933-33	DIODE HZS6A1L
C723	1-124-893-11	ELECT	2200MF	20%	6.3V	D710	8-719-933-41	DIODE HZS6C3L
C801	1-162-294-31	CERAMIC	0.001MF	10%	50V	D711	8-719-200-77	DIODE 10E2N
C802	1-162-294-31	CERAMIC	0.001MF	10%	50V	D712	8-719-200-77	DIODE 10E2N
C803	1-124-902-00	ELECT	0.47MF	20%	50V	D713	8-719-200-77	DIODE 10E2N
C804	1-164-159-11	CERAMIC	0.1MF		50V	D714	8-719-200-77	DIODE 10E2N
C805	1-164-159-11	CERAMIC	0.1MF		50V	D715	8-719-200-77	DIODE 10E2N
C806	1-124-477-11	ELECT	47MF	20%	16V	D716	8-719-200-77	DIODE 10E2N
C808	1-124-446-11	ELECT	47MF	20%	10V	D717	8-719-107-94	DIODE 1SS202-1
C809	1-123-875-11	ELECT	10MF	20%	50V	D719	8-719-107-94	DIODE 1SS202-1
C810	1-161-494-00	CERAMIC	0.022MF		25V	D720	8-719-001-79	DIODE UZL-12H1
C811	1-124-927-11	ELECT	4.7MF	20%	50V	D721	8-719-000-93	DIODE UZL-7H1
C812	1-161-494-00	CERAMIC	0.022MF		25V	D722	8-719-107-94	DIODE 1SS202-1
C814	1-161-494-00	CERAMIC	0.022MF	30%	25V	D723	8-719-107-94	DIODE 1SS202-1
C816	1-162-294-31	CERAMIC	0.001MF	10%	50V	D724	8-719-933-33	DIODE HZS6A1L
C853	1-123-875-11	ELECT	10MF	20%	50V	D801	8-719-107-94	DIODE 1SS202-1
C1051	1-123-875-11	ELECT	10MF	20%	50V	D802	8-719-107-94	DIODE 1SS202-1
C1052	1-123-875-11	ELECT	10MF	20%	50V	D803	8-719-107-94	DIODE 1SS202-1
C1053	1-164-159-11	CERAMIC	0.1MF		50V	D804	8-719-107-94	DIODE 1SS202-1
CN1001	1-506-615-11	PIN, CONNECTOR	9P			D805	8-719-107-94	DIODE 1SS202-1
CN1002	1-564-501-11	PIN, CONNECTOR	8P			D808	8-719-107-94	DIODE 1SS202-1
CN1051*	1-564-499-11	PIN, CONNECTOR	6P			D809	8-719-107-94	DIODE 1SS202-1
CN1052*	1-564-718-11	PIN, CONNECTOR (SMALL TYPE)	2P			D811	8-719-107-94	DIODE 1SS202-1
CN1053*	1-564-718-11	PIN, CONNECTOR (SMALL TYPE)	2P			D812	8-719-107-94	DIODE 1SS202-1
CND507*	1-564-337-71	PIN, CONNECTOR	3P			D813	8-719-107-94	DIODE 1SS202-1
CND508*	1-564-337-61	PIN, CONNECTOR	3P			D814	8-719-107-94	DIODE 1SS202-1
CND509*	1-564-338-00	PIN, CONNECTOR	4P			D815	8-719-107-94	DIODE 1SS202-1
CND510*	1-564-337-00	PIN, CONNECTOR	3P			D818	8-719-107-94	DIODE 1SS202-1
CND801*	1-564-338-71	PIN, CONNECTOR	4P			D819	8-719-107-94	DIODE 1SS202-1
CND802*	1-564-337-81	PIN, CONNECTOR	3P			D820	8-719-107-94	DIODE 1SS202-1
CND803*	1-564-339-00	PIN, CONNECTOR	5P			D1051	8-719-980-85	DIODE SLF-325C
CNE501*	1-564-509-11	PLUG, CONNECTOR	6P			FLT851	1-519-596-11	INDICATOR TUBE, FLUORESCENT
CNE502*	1-564-506-11	PLUG, CONNECTOR	3P			HE1001	1-543-535-11	HEAD, MAGNETIC (ERASE)
CNE503*	1-564-506-11	PLUG, CONNECTOR	3P			HRP1001	1-543-537-11	HEAD, MAGNETIC (REC/PB)
CNE506*	1-564-506-11	PLUG, CONNECTOR	3P					
CNE804*	1-564-506-11	PLUG, CONNECTOR	3P					
CNE805*	1-564-505-11	PLUG, CONNECTOR	2P					
CNN701*	1-508-882-00	BASE POST						

Ref.No.	Part No.	Description	Ref.No.	Part No.	Description
IC501	8-759-111-44	IC UPC4570C-1	Q709	8-729-900-61	TRANSISTOR DTA114ES
IC502	8-759-634-51	IC M5218AP	Q710	8-729-920-98	TRANSISTOR 2SD1761-EF
IC503	8-759-945-58	IC RC4558P	Q711	8-729-620-05	TRANSISTOR 2SC2603-EF
IC504	8-759-945-58	IC RC4558P	Q712	8-729-900-80	TRANSISTOR DTC114ES
IC505	8-752-036-34	IC CXA1330S	Q801	8-729-900-61	TRANSISTOR DTA114ES
IC506	8-752-038-02	IC CXA1198AP	Q802	8-729-900-61	TRANSISTOR DTA114ES
IC507	8-759-106-56	IC UPC1297CA	Q803	8-729-900-61	TRANSISTOR DTA114ES
IC701	8-759-945-58	IC RC4558P	Q804	8-729-900-61	TRANSISTOR DTA114ES
IC801	8-759-634-99	IC M50941-3545P	Q805	8-729-119-76	TRANSISTOR 2SA1175-HFE
IC802	8-759-240-69	IC TC4069UBP	Q806	8-729-119-76	TRANSISTOR 2SA1175-HFE
IC803	8-759-973-95	IC BA6219B	Q807	8-729-900-61	TRANSISTOR DTA114ES
IC804	8-759-822-09	IC LB1641	Q808	8-729-900-61	TRANSISTOR DTA114ES
IC851	8-741-100-48	IC SBX1610-59	Q809	8-729-620-05	TRANSISTOR 2SC2603-EF
IC1001	8-749-920-97	PHOTO REFLECTOR GP2S22B	Q810	8-729-620-05	TRANSISTOR 2SC2603-EF
IC1002	8-749-920-97	PHOTO REFLECTOR GP2S22B	Q811	8-729-900-61	TRANSISTOR DTA114ES
J501	1-565-258-11	JACK, PIN 4P (LINE IN/LINE OUT)	Q812	8-729-900-80	TRANSISTOR DTC114ES
J502	1-507-796-71	JACK (HEADPHONES)	Q813	8-729-900-80	TRANSISTOR DTC114ES
L101	1-410-780-11	INDUCTOR 27MMH	Q814	8-729-620-05	TRANSISTOR 2SC2603-EF
L201	1-410-780-11	INDUCTOR 27MMH	Q815	8-729-620-05	TRANSISTOR 2SC2603-EF
L501	1-408-080-00	INDUCTOR 100UH	Q851	8-729-900-61	TRANSISTOR DTA114ES
LPF101	1-231-388-00	FILTER, LOW PASS	Q853	8-729-900-61	TRANSISTOR DTA114ES
LPF201	1-231-388-00	FILTER, LOW PASS	Q854	8-729-900-61	TRANSISTOR DTA114ES
M1051	X-3356-638-1	MOTOR (REEL R) ASSY	Q855	8-729-900-61	TRANSISTOR DTA114ES
M1052	X-3356-604-1	MOTOR (ASSIST) ASSY	Q856	8-729-900-61	TRANSISTOR DTA114ES
M1053	X-3356-646-1	MOTOR (CAPSTAN V1) ASSY	Q857	8-729-900-61	TRANSISTOR DTA114ES
Q101	8-729-900-74	TRANSISTOR DTC143TS	Q858	8-729-900-61	TRANSISTOR DTA114ES
Q102	8-729-900-80	TRANSISTOR DTC114ES	R101	1-247-891-00	CARBON 330K 5% 1/4W
Q103	8-729-142-25	TRANSISTOR 2SD1020-HFE	R102	1-249-403-11	CARBON 68 5% 1/4W
Q104	8-729-620-05	TRANSISTOR 2SC2603-EF	R103	1-247-882-11	CARBON 130K 5% 1/4W
Q201	8-729-900-74	TRANSISTOR DTC143TS	R104	1-247-848-11	CARBON 5.1K 5% 1/4W
Q202	8-729-900-80	TRANSISTOR DTC114ES	R105	1-249-421-11	CARBON 2.2K 5% 1/4W
Q203	8-729-142-25	TRANSISTOR 2SD1020-HFE	R106	1-247-840-00	CARBON 2.4K 5% 1/4W
Q204	8-729-620-05	TRANSISTOR 2SC2603-EF	R107	1-247-887-00	CARBON 220K 5% 1/4W
Q501	8-729-119-76	TRANSISTOR 2SA1175-HFE	R109	1-249-421-11	CARBON 2.2K 5% 1/4W
Q502	8-729-620-05	TRANSISTOR 2SC2603-EF	R110	1-249-433-11	CARBON 22K 5% 1/4W
Q503	8-729-900-61	TRANSISTOR DTA114ES	R111	1-249-417-11	CARBON 1K 5% 1/4W
Q504	8-729-900-80	TRANSISTOR DTC114ES	R112	1-249-429-11	CARBON 10K 5% 1/4W
Q505	8-729-900-61	TRANSISTOR DTA114ES	R113	1-249-421-11	CARBON 2.2K 5% 1/4W
Q506	8-729-821-04	TRANSISTOR 2SA1317-STU	R114	1-249-421-11	CARBON 2.2K 5% 1/4W
Q511	8-729-900-74	TRANSISTOR DTC143TS	R115	1-249-409-11	CARBON 220 5% 1/4W
Q512	8-729-900-74	TRANSISTOR DTC143TS	R116	1-249-434-11	CARBON 27K 5% 1/4W
Q513	8-729-900-74	TRANSISTOR DTC143TS	R117	1-247-868-11	CARBON 36K 5% 1/4W
Q515	8-729-900-80	TRANSISTOR DTC114ES	R118	1-247-862-11	CARBON 20K 5% 1/4W
Q516	8-729-900-80	TRANSISTOR DTC114ES	R119	1-249-408-11	CARBON 180 5% 1/4W
Q518	8-729-900-80	TRANSISTOR DTC114ES	R120	1-249-441-11	CARBON 100K 5% 1/4W
Q519	8-729-194-57	TRANSISTOR 2SC945-P	R121	1-249-423-11	CARBON 3.3K 5% 1/4W
Q520	8-729-194-57	TRANSISTOR 2SC945-P	R122	1-249-441-11	CARBON 100K 5% 1/4W
Q701	8-729-900-80	TRANSISTOR DTC114ES	R123	1-249-428-11	CARBON 8.2K 5% 1/4W
Q702	8-729-920-97	TRANSISTOR 2SB1187-EF	R124	1-249-421-11	CARBON 2.2K 5% 1/4W
Q703	8-729-920-98	TRANSISTOR 2SD1761-EF	R125	1-249-428-11	CARBON 8.2K 5% 1/4W
Q704	8-729-922-37	TRANSISTOR 2SD2144S	R126	1-247-864-11	CARBON 24K 5% 1/4W
Q705	8-729-920-98	TRANSISTOR 2SD1761-EF	R127	1-249-414-11	CARBON 560 5% 1/4W
Q706	8-729-141-32	TRANSISTOR 2SA1409TP	R130	1-249-421-11	CARBON 2.2K 5% 1/4W
Q707	8-729-140-04	TRANSISTOR 2SB1116A-L	R161	1-249-429-11	CARBON 10K 5% 1/4W
Q708	8-729-900-80	TRANSISTOR DTC114ES	R162	1-249-425-11	CARBON 4.7K 5% 1/4W
			R163	1-249-421-11	CARBON 2.2K 5% 1/4W

Ref.No.	Part No.	Description					Ref.No.	Part No.	Description				
R164	1-249-421-11	CARBON	2.2K	5%	1/4W		R516	1-249-441-11	CARBON	100K	5%	1/4W	
R166	1-249-430-11	CARBON	12K	5%	1/4W		R517	1-249-429-11	CARBON	10K	5%	1/4W	
R167	1-249-431-11	CARBON	15K	5%	1/4W		R518	1-249-429-11	CARBON	10K	5%	1/4W	
R168	1-249-432-11	CARBON	18K	5%	1/4W		R519	1-249-417-11	CARBON	1K	5%	1/4W	
R169	1-249-393-11	CARBON	10	5%	1/4W		R520	1-249-441-11	CARBON	100K	5%	1/4W	
R170	1-247-883-00	CARBON	150K	5%	1/4W		R521	1-249-425-11	CARBON	4.7K	5%	1/4W	
R173	1-249-429-11	CARBON	10K	5%	1/4W		R522	1-247-864-11	CARBON	24K	5%	1/4W	
R201	1-247-891-00	CARBON	330K	5%	1/4W		R523	1-249-429-11	CARBON	10K	5%	1/4W	
R202	1-249-403-11	CARBON	68	5%	1/4W		R524	1-249-431-11	CARBON	15K	5%	1/4W	
R203	1-247-882-11	CARBON	130K	5%	1/4W		R525	1-249-421-11	CARBON	2.2K	5%	1/4W	
R204	1-247-848-11	CARBON	5.1K	5%	1/4W		R526	1-247-842-11	CARBON	3K	5%	1/4W	
R205	1-249-421-11	CARBON	2.2K	5%	1/4W		R527	1-249-438-11	CARBON	56K	5%	1/4W	
R206	1-247-840-00	CARBON	2.4K	5%	1/4W		R528	1-249-438-11	CARBON	56K	5%	1/4W	
R207	1-247-887-00	CARBON	220K	5%	1/4W		R530	1-249-441-11	CARBON	100K	5%	1/4W	
R209	1-249-421-11	CARBON	2.2K	5%	1/4W		R531	1-247-876-11	CARBON	75K	5%	1/4W	
R210	1-249-433-11	CARBON	22K	5%	1/4W		R532	1-249-390-11	CARBON	5.6	5%	1/4W	
R211	1-249-417-11	CARBON	1K	5%	1/4W		R533	1-249-390-11	CARBON	5.6	5%	1/4W	
R212	1-249-429-11	CARBON	10K	5%	1/4W		R534	1-249-413-11	CARBON	470	5%	1/4W	
R213	1-249-421-11	CARBON	2.2K	5%	1/4W		R535	1-249-413-11	CARBON	470	5%	1/4W	
R214	1-249-421-11	CARBON	2.2K	5%	1/4W		R537	1-249-403-11	CARBON	68	5%	1/4W	
R215	1-249-409-11	CARBON	220	5%	1/4W		R538	1-249-427-11	CARBON	6.8K	5%	1/4W	
R216	1-249-434-11	CARBON	27K	5%	1/4W		R539	1-249-417-11	CARBON	1K	5%	1/4W	
R217	1-247-868-11	CARBON	36K	5%	1/4W		R540	1-249-434-11	CARBON	27K	5%	1/4W	
R218	1-247-862-11	CARBON	20K	5%	1/4W		R541	1-247-844-11	CARBON	3.6K	5%	1/4W	
R219	1-249-408-11	CARBON	180	5%	1/4W		R542	1-249-435-11	CARBON	33K	5%	1/4W	
R220	1-249-441-11	CARBON	100K	5%	1/4W		R543	1-247-858-11	CARBON	13K	5%	1/4W	
R221	1-249-423-11	CARBON	3.3K	5%	1/4W		R544	1-247-872-11	CARBON	57K	5%	1/4W	
R222	1-249-441-11	CARBON	100K	5%	1/4W		R545	1-249-438-11	CARBON	56K	5%	1/4W	
R223	1-249-428-11	CARBON	8.2K	5%	1/4W		R546	1-247-884-11	CARBON	160K	5%	1/4W	
R224	1-249-421-11	CARBON	2.2K	5%	1/4W		R547	1-247-882-11	CARBON	130K	5%	1/4W	
R225	1-249-428-11	CARBON	8.2K	5%	1/4W		R548	1-247-868-11	CARBON	36K	5%	1/4W	
R226	1-247-864-11	CARBON	24K	5%	1/4W		R549	1-249-438-11	CARBON	56K	5%	1/4W	
R227	1-249-414-11	CARBON	560	5%	1/4W		R550	1-247-891-00	CARBON	330K	5%	1/4W	
R230	1-249-421-11	CARBON	2.2K	5%	1/4W		R551	1-247-872-11	CARBON	51K	5%	1/4W	
R261	1-249-429-11	CARBON	10K	5%	1/4W		R552	1-247-884-11	CARBON	160K	5%	1/4W	
R262	1-249-425-11	CARBON	4.7K	5%	1/4W		R553	1-247-890-11	CARBON	300K	5%	1/4W	
R263	1-249-421-11	CARBON	2.2K	5%	1/4W		R554	1-249-437-11	CARBON	47K	5%	1/4W	
R264	1-249-421-11	CARBON	2.2K	5%	1/4W		R555	1-247-874-11	CARBON	62K	5%	1/4W	
R266	1-249-430-11	CARBON	12K	5%	1/4W		R556	1-247-887-00	CARBON	220K	5%	1/4W	
R267	1-249-431-11	CARBON	15K	5%	1/4W		R557	1-249-439-11	CARBON	68K	5%	1/4W	
R268	1-249-432-11	CARBON	18K	5%	1/4W		R558	1-247-878-00	CARBON	91K	5%	1/4W	
R269	1-249-393-11	CARBON	10	5%	1/4W		R559	1-247-880-11	CARBON	110K	5%	1/4W	
R270	1-247-883-00	CARBON	150K	5%	1/4W		R560	1-249-438-11	CARBON	56K	5%	1/4W	
R273	1-249-429-11	CARBON	10K	5%	1/4W		R702	1-249-425-11	CARBON	4.7K	5%	1/4W	
R501	1-249-409-11	CARBON	220	5%	1/4W		R703	1-249-420-11	CARBON	1.8K	5%	1/4W	
R502	1-249-409-11	CARBON	220	5%	1/4W		R704	1-249-412-11	CARBON	390	5%	1/4W	
R503	1-249-409-11	CARBON	220	5%	1/4W		R705	1-249-427-11	CARBON	6.8K	5%	1/4W	
R504	1-249-409-11	CARBON	220	5%	1/4W		R706	1-249-419-11	CARBON	1.5K	5%	1/4W	
R506	1-249-429-11	CARBON	10K	5%	1/4W		R707	1-249-429-11	CARBON	10K	5%	1/4W	
R507	1-249-429-11	CARBON	10K	5%	1/4W		R708	1-247-836-11	CARBON	1.6K	5%	1/4W	
R508	1-249-429-11	CARBON	10K	5%	1/4W		R709	1-249-425-11	CARBON	4.7K	5%	1/4W	
R510	1-249-441-11	CARBON	100K	5%	1/4W		R710	1-249-409-11	CARBON	220	5%	1/4W	
R511	1-249-429-11	CARBON	10K	5%	1/4W		R711	1-249-427-11	CARBON	6.8K	5%	1/4W	
R512	1-249-441-11	CARBON	100K	5%	1/4W		R712	1-249-427-11	CARBON	6.8K	5%	1/4W	
R513	1-249-428-11	CARBON	8.2K	5%	1/4W		R713	1-249-417-11	CARBON	1K	5%	1/4W	
R514	1-249-441-11	CARBON	100K	5%	1/4W		R714	1-249-426-11	CARBON	5.6K	5%	1/4W	
R515	1-249-423-11	CARBON	3.3K	5%	1/4W		R715	1-249-425-11	CARBON	4.7K	5%	1/4W	

Note:
The components identified by mark Δ or dotted line with mark Δ are critical for safety. Replace only with part number specified.

Note:
Les composants identifiés par une marque Δ sont critiques pour la sécurité. Ne les remplacer que par une pièce portant le numéro spécifié.

Ref.No.	Part No.	Description							
R716	1-249-421-11	CARBON	2.2K	5%	1/4W				
R717	1-249-429-11	CARBON	10K	5%	1/4W				
R718	1-249-429-11	CARBON	10K	5%	1/4W				
R719	1-249-433-11	CARBON	22K	5%	1/4W				
R720	1-249-426-11	CARBON	5.6K	5%	1/4W				
R721	1-249-430-11	CARBON	12K	5%	1/4W				
R722	1-247-752-11	CARBON	1K	5%	1/2W				
R724	1-249-433-11	CARBON	22K	5%	1/4W				
R725	1-249-421-11	CARBON	2.2K	5%	1/4W				
R726	1-247-887-00	CARBON	220K	5%	1/4W				
R727	1-249-425-11	CARBON	4.7K	5%	1/4W				
R728	1-249-435-11	CARBON	33K	5%	1/4W				
R729	1-247-903-00	CARBON	1M	5%	1/4W				
R730	1-249-414-11	CARBON	560	5%	1/4W				
R731	Δ 1-219-135-11	FUSIBLE	0.15	10%	1/4W				
R732	Δ 1-219-135-11	FUSIBLE	0.15	10%	1/4W				
R801	1-247-887-00	CARBON	220K	5%	1/4W				
R802	1-247-887-00	CARBON	220K	5%	1/4W				
R803	1-249-436-11	CARBON	39K	5%	1/4W				
R804	1-247-887-00	CARBON	220K	5%	1/4W				
R805	1-249-436-11	CARBON	39K	5%	1/4W				
R806	1-247-887-00	CARBON	220K	5%	1/4W				
R807	1-249-430-11	CARBON	12K	5%	1/4W				
R808	1-249-435-11	CARBON	33K	5%	1/4W				
R809	1-249-435-11	CARBON	33K	5%	1/4W				
R812	1-249-435-11	CARBON	33K	5%	1/4W				
R813	1-249-435-11	CARBON	33K	5%	1/4W				
R814	1-249-435-11	CARBON	33K	5%	1/4W				
R815	1-249-435-11	CARBON	33K	5%	1/4W				
R816	1-249-435-11	CARBON	33K	5%	1/4W				
R817	1-249-435-11	CARBON	33K	5%	1/4W				
R818	1-249-435-11	CARBON	33K	5%	1/4W				
R819	1-249-435-11	CARBON	33K	5%	1/4W				
R820	Δ 1-212-954-11	FUSIBLE	6.8	5%	1/2W	F			
R821	1-249-429-11	CARBON	10K	5%	1/4W				
R822	1-249-431-11	CARBON	15K	5%	1/4W				
R823	1-247-834-11	CARBON	1.3K	5%	1/4W				
R824	1-249-424-11	CARBON	3.9K	5%	1/4W				
R825	1-249-423-11	CARBON	3.3K	5%	1/4W				
R826	1-249-427-11	CARBON	6.8K	5%	1/4W				
R827	1-249-429-11	CARBON	10K	5%	1/4W				
R828	Δ 1-212-952-00	FUSIBLE	5.6	5%	1/2W	F			
R829	1-249-435-11	CARBON	33K	5%	1/4W				
R830	1-249-435-11	CARBON	33K	5%	1/4W				
R831	1-249-425-11	CARBON	4.7K	5%	1/4W				
R832	1-249-417-11	CARBON	1K	5%	1/4W				
R833	1-249-433-11	CARBON	22K	5%	1/4W				
R834	1-249-403-11	CARBON	68	5%	1/4W				
R851	1-249-441-11	CARBON	100K	5%	1/4W				
R852	1-249-441-11	CARBON	100K	5%	1/4W				
R853	1-249-441-11	CARBON	100K	5%	1/4W				
R854	1-249-441-11	CARBON	100K	5%	1/4W				
R855	1-249-441-11	CARBON	100K	5%	1/4W				
R856	1-249-441-11	CARBON	100K	5%	1/4W				
R857	1-249-441-11	CARBON	100K	5%	1/4W				
R858	1-249-441-11	CARBON	100K	5%	1/4W				
R859	1-249-422-11	CARBON	2.7K	5%	1/4W				
R860	1-249-424-11	CARBON	3.9K	5%	1/4W				
R861	1-249-428-11	CARBON	8.2K	5%	1/4W				
R862	1-249-434-11	CARBON	27K	5%	1/4W				
R863	1-249-422-11	CARBON	2.7K	5%	1/4W				
R864	1-249-424-11	CARBON	3.9K	5%	1/4W				
R866	1-249-422-11	CARBON	2.7K	5%	1/4W				
R867	1-249-424-11	CARBON	3.9K	5%	1/4W				
R868	1-247-872-11	CARBON	51K	5%	1/4W				
R869	1-249-434-11	CARBON	27K	5%	1/4W				
R870	1-249-429-11	CARBON	10K	5%	1/4W				
R871	1-249-429-11	CARBON	10K	5%	1/4W				
R872	1-249-429-11	CARBON	10K	5%	1/4W				
R873	1-249-429-11	CARBON	10K	5%	1/4W				
R876	1-249-431-11	CARBON	15K	5%	1/4W				
R1001	1-249-408-11	CARBON	180	5%	1/4W				
R1002	1-249-408-11	CARBON	180	5%	1/4W				
R1051	1-249-414-11	CARBON	560	5%	1/4W				
RV101	1-238-016-11	RES, ADJ, CARBON 10K (PB LEVEL)							
RV102	1-238-016-11	RES, ADJ, CARBON 10K (REC LEVEL)							
RV103	1-238-017-11	RES, ADJ, CARBON 22K (REC BIAS)							
RV201	1-238-016-11	RES, ADJ, CARBON 10K (PB LEVEL)							
RV202	1-238-016-11	RES, ADJ, CARBON 10K (REC LEVEL)							
RV203	1-238-017-11	RES, ADJ, CARBON 22K (REC BIAS)							
RV501	1-241-045-12	RES, VAR, CARBON 50K/50K (REC LEVEL)							
RV502	1-238-904-11	RES, VAR, CARBON 50K/50K (BALANCE)							
RV503	1-241-046-11	RES, VAR, CARBON 5K (BIAS)							
RY501	1-515-683-11	RELAY							
S501	1-572-154-11	SWITCH, ROTARY (DOLBY NR)							
S502	1-571-305-11	SWITCH, PUSH (1 KEY)(MPX FILTER)							
S701	1-571-305-11	SWITCH, PUSH (1 KEY)(POWER)							
S851	1-554-303-21	SWITCH, KEY BOARD (OPEN/CLOSE)							
S852	1-554-303-21	SWITCH, KEY BOARD (STOP)							
S853	1-554-303-21	SWITCH, KEY BOARD (REW)							
S854	1-554-303-21	SWITCH, KEY BOARD (FF)							
S855	1-554-303-21	SWITCH, KEY BOARD (REC)							
S856	1-554-303-21	SWITCH, KEY BOARD (FWD)							
S857	1-554-303-21	SWITCH, KEY BOARD (PAUSE)							
S858	1-554-303-21	SWITCH, KEY BOARD (REC MUTE)							
S859	1-554-303-21	SWITCH, KEY BOARD (RESET)							
S860	1-554-303-21	SWITCH, KEY BOARD (MEMORY)							
S861	1-554-303-21	SWITCH, KEY BOARD (DISPLAY MODE)							
S863	1-571-520-11	SWITCH, SLIDE (TIMER)							
S1001	1-466-238-11	ENCODER, ROTARY							
S1002	1-570-953-11	SWITCH, PUSH (1 KEY)(DOOR)							
S1003	1-571-958-11	SWITCH, PUSH (1 KEY)(CLOSE)							
S1004	1-572-126-11	SWITCH, PUSH (1 KEY)(OPEN)							
S1005	1-572-125-11	SWITCH, LEAF (REC)							
S1006	1-572-202-11	SWITCH, LEAF (HALF)							
S1007	1-572-125-11	SWITCH, LEAF (METAL)							
S1008	1-572-125-11	SWITCH, LEAF (70US)							
T101	1-433-354-11	TRANSFORMER, BIAS OSCILLATION							
T201	1-433-354-11	TRANSFORMER, BIAS OSCILLATION							
T501	1-433-355-11	TRANSFORMER, BIAS OSCILLATION							
T901	Δ 1-450-099-11	(AEP,UK,WG)...TRANSFORMER, POWER							
T901	Δ 1-450-100-11	(Canadian)...TRANSFORMER, POWER							
TB1001*1	1-569-066-11	PIN, CONNECTOR 5P							
X801	1-577-359-21	VIBRATOR, CERAMIC 4.19MHZ							

ACCESSORY & PACKING MATERIAL

1-659-533-11 CORD, CONNECTION
*3-350-829-71 INDIVIDUAL CARTON
*3-350-830-01 CUSHION

3-751-743-11 (AEP,UK,Canadian)...MANUAL, INSTRUCTION
(ENGLISH,FRENCH,SPANISH)
3-751-743-41 (AEP)...MANUAL, INSTRUCTION
(GERMAN,DUTCH,SWEDISH,ITALIAN)
3-751-743-51 (WG)...MANUAL, INSTRUCTION (GERMAN)