

TC-K411/K511S

SERVICE MANUAL

AEP Model
UK Model
Australian Model

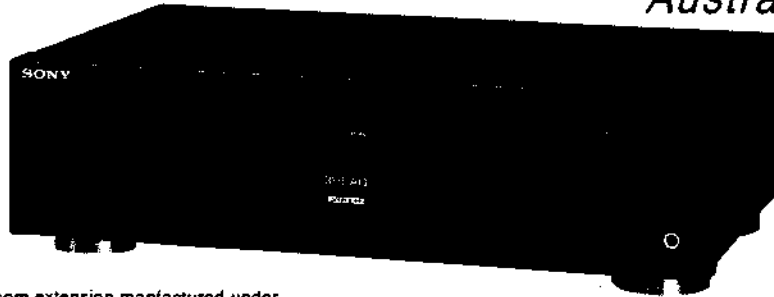

• Dolby noise reduction and HX Pro headroom extension manufactured under license from Dolby Laboratories Licensing Corporation. HX Pro originated by Bang & Olufsen.

"DOLBY", the double-D symbol  and "HX PRO" are trademarks of Dolby Laboratories Licensing Corporation.

PHOTO : TC-K511S

Model Name Using Similar Mechanism	TC-K490
Tape Transport Mechanism Type	TCM-190VB11

SPECIFICATIONS

Recording system 4-track 2-channel stereo
Fast winding time Approx. 90 sec. (with Sony C-60 cassette)
Bias AC bias
Heads Erasing head × 1 (S&F head)
Recording head × 1 (SD head)
Playback head × 1 (SD head)
Motors Capstan motor × 1 (DC servo motor)
Reel motor × 1 (DC motor)

Signal-to-noise ratio (at peak level and weighted)

Cassette (Dolby NR off)	Type IV	Type II	Type I
	60 dB	59 dB	57 dB

S/N ratio improvement (approximate values).

With Dolby B NR on: 5 dB at 1 kHz; 10 dB at 5 kHz
With Dolby C NR on: 15 dB at 500 Hz; 20 dB at 1 kHz
With Dolby S NR on: 10 dB at 100 Hz; 24 dB at 1 kHz (TC-K511S only)

Harmonic distortion 0.4% (with Type I, 160 nWb/m 315 Hz, 3rd H.D.)
1.5% (with Type IV, 250 nWb/m 315 Hz, 3rd H.D.)

Frequency response (DOLBY NR off)

Type IV cassette	30 - 19,000 Hz (±3 dB, IEC) 30 - 16,000 Hz (±3 dB (-4dB recording))
Type II cassette	30 - 18,000 Hz (±3 dB, IEC)
Type I cassette	30 - 17,000 Hz (±3 dB, IEC)

Type IV : Sony METAL-S
Type II : Sony UX-S
Type I : Sony HF-S

Wow and flutter ± 0.13% W.Peak (IEC)
0.07% W.RMS (NAB)
± 0.18% W.Peak (DIN)

Inputs

Line inputs (phono jacks)	Sensitivity	0.16 V
	Input impedance	47 k ohms

Outputs

Line outputs (phono jacks)	Rated output level	0.5 V at a load impedance of 47 k ohms
	Load impedance	Over 10 k ohms
Headphones (stereo phone jack)	Output level	1 mW at a load impedance of 32 ohms

General

Power requirements AEP, Germany Model : 220-230V AC, 50/60 Hz
UK, Australian Model : 240V AC, 50/60 Hz
23 W
Power consumption
Dimensions Approx. 430 × 123 × 310 mm (w/h/d)
(17 × 4⁷/₈ × 12¹/₄ inches)
including projecting parts and controls
Mass Approx. 4 kg (8 lbs 14 oz)
Supplied accessories Audio connecting cords (2)
Optional accessory Wireless remote control unit RM-J701

Design and specifications are subject to change without notice.

Note

This appliance conforms with EEC Directive 87/308/EEC regarding interference suppression.



STEREO CASSETTE DECK
SONY

TABLE OF CONTENTS

<i>Section</i>	<i>Title</i>	<i>Page</i>	<i>Section</i>	<i>Title</i>	<i>Page</i>
	Specifications	1	5. DIAGRAMS		
1. GENERAL			5-1. Circuit Boards Location		14
	Identifying the Parts	3	5-2. Printed Wiring Boards (Main Section)		16
	Recording	4	5-3. Schematic Diagram (Main Section)		19
2. DISASSEMBLY			5-4. Printed Wiring Boards (Dolby (S) Board)		25
2-1. Front Panel		5	5-5. Schematic Diagram (Dolby (S) Board)		26
2-2. Mechanism Deck		5	6. EXPLODED VIEWS		
2-3. Head		6	6-1. Chassis Section		28
2-4. Fitting Base Block		6	6-2. Front Panel Section		29
2-5. Motor		6	6-3. Mechanism Section 1		30
3. EXPLANATION OF IC TERMINALS		7	6-4. Mechanism Section 2		31
4. ADJUSTMENTS			7. ELECTRICAL PARTS LIST		32
4-1. Mechanical Adjustments		9			
4-2. Electrical Adjustments		9			

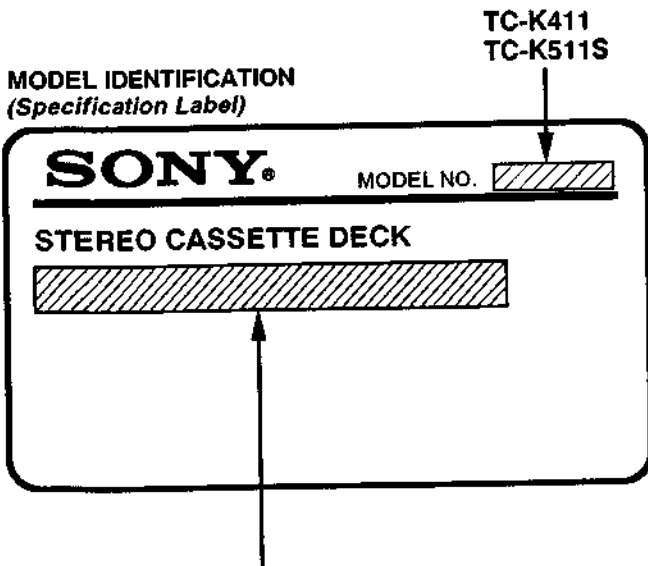

AEP, Germany model : AC 220-230V -50/60Hz
 UK, Australian model : AC 240V-50/60Hz

SAFETY-RELATED COMPONENT WARNING!!

COMPONENTS IDENTIFIED BY MARK \triangle OR DOTTED LINE WITH MARK \triangle ON THE SCHEMATIC DIAGRAMS AND IN THE PARTS LIST ARE CRITICAL TO SAFE OPERATION. REPLACE THESE COMPONENTS WITH SONY PARTS WHOSE PART NUMBERS APPEAR AS SHOWN IN THIS MANUAL OR IN SUPPLEMENTS PUBLISHED BY SONY.

SECTION 1 GENERAL

1-1. IDENTIFYING THE PARTS

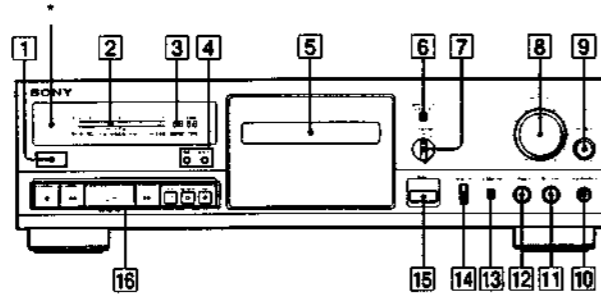

Front Panel

For details, refer to the page number(s) indicated in parentheses.

- 1 POWER switch
- 2 Peak level meter
- 3 Linear counter
- 4 COUNTER buttons
RESET button
MEMORY button
- 5 Cassette holder
- 6 MPX FILTER button
- 7 DOLBY NR (noise reduction) switch
- 8 REC (recording) LEVEL control
- 9 BALANCE control
- 10 HEADPHONES jack (stereo phone jack)
- 11 REC (recording) LEVEL control for calibration
- 12 BIAS control
- 13 CALIBRATION button
- 14 MONITOR button
- 15 (eject) button
- 16 Tape operation buttons
■ (stop) button
◀ (rewind) button
▶ (play) button
▶▶ (fast-forward) button
|| PAUSE button
○ REC MUTE (record muting) button
● REC (recording) button

* Remote control sensor

You can remotely control this cassette deck with:

- A remote commander that came with a Sony amplifier or receiver if it has the ■ mark and cassette deck control capability.
- An optional Sony remote commander with the ■ mark and cassette deck control capability.

This section is extracted from instruction manual.

1-2. RECORDING

A

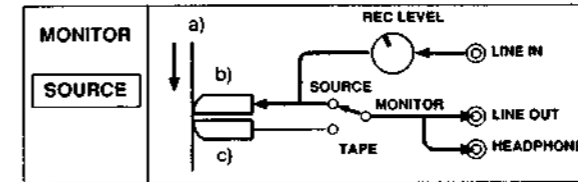

B

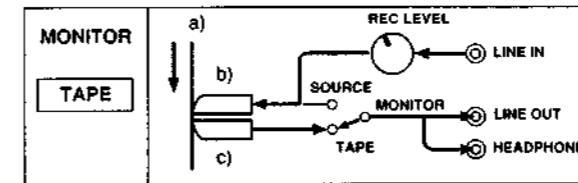

Monitoring the Recorded Sound

As this unit has three separate heads for recording, playback and erasure, you can check the quality of a recorded sound by comparing it with the input source signal.

To listen to the input source signal, press the MONITOR button to turn on the SOURCE indicator. (Fig. A)

To listen to the sound recorded on the tape, press the MONITOR button to turn on the TAPE indicator. (Fig. B)

Fig. A and B show the MONITOR switch setting and their respective signal flow.

- a) Band
- b) Recording head
- c) Playback head

Comparing the recorded sound with the sound source

While recording, use this monitoring function to check that there is no distortion due to excessive level settings or sound degradation due to head contamination.

What Is the Dolby HX PRO System?

The Dolby HX PRO system provides improved linearity in high-range frequency response during recording. Tapes recorded with this system retain the same high quality even when played back on other tape decks.

As shown in Fig. A, characteristics such as output level and distortion differ widely according to the bias (high-frequency) current.

Fig. A

- a) High
- b) Distortion output
- c) 315 Hz
- d) 6.3 kHz
- e) 10 kHz
- f) 315 Hz distortion
- g) Bias current
- h) High
- i) Established bias current

In conventional systems (see Fig. B), the bias current is susceptible to variations in certain recording signals which may cause fluctuations in frequency response, distortion, or other unwanted characteristics.

Fig. B

- a) High
- b) Output
- c) Fluctuation
- d) Frequency
- e) High

With the Dolby HX PRO system, the effective bias amount added to the bias current is controlled in millisecond units to greatly reduce distortion, improving linearity in high-range response and ensuring high-intensity recording with minimal distortion and noise.

SECTION 2 DISASSEMBLY

Note : Follow the disassembly procedure in the numerical order given.

CASE
Unscrew the four case attachment screws M3×8 and remove the case.

2-1. FRONT PANEL

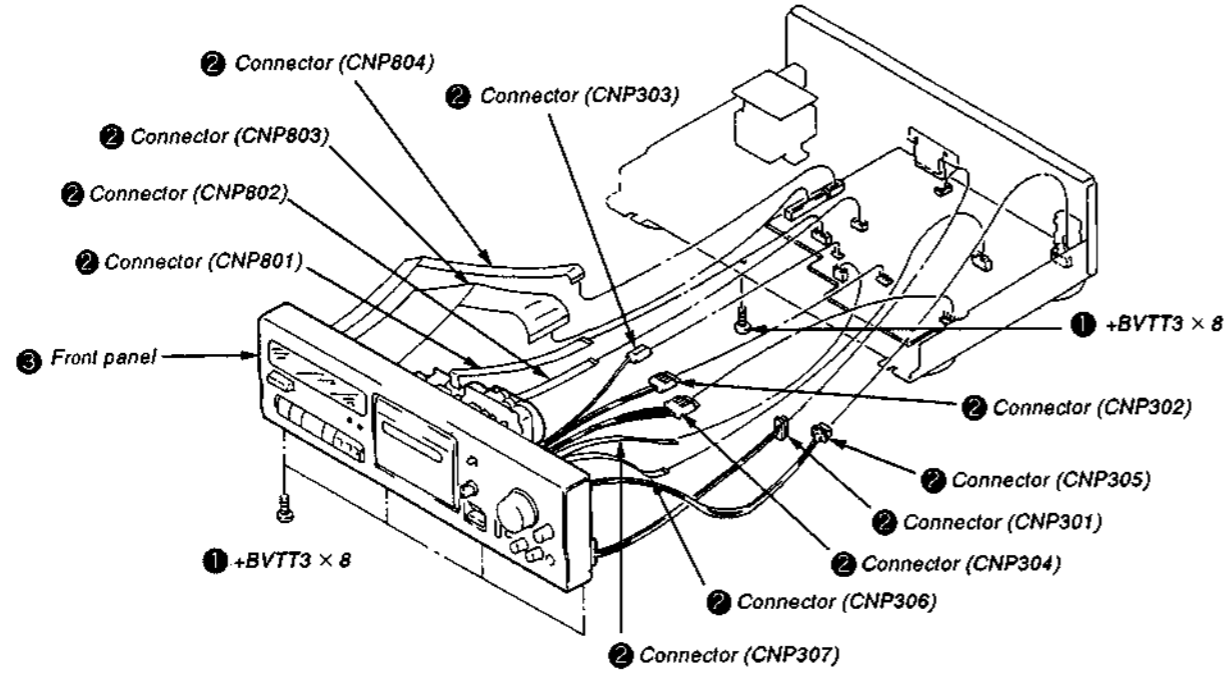

2-2. MECHANISM DECK

1 Press the eject button.

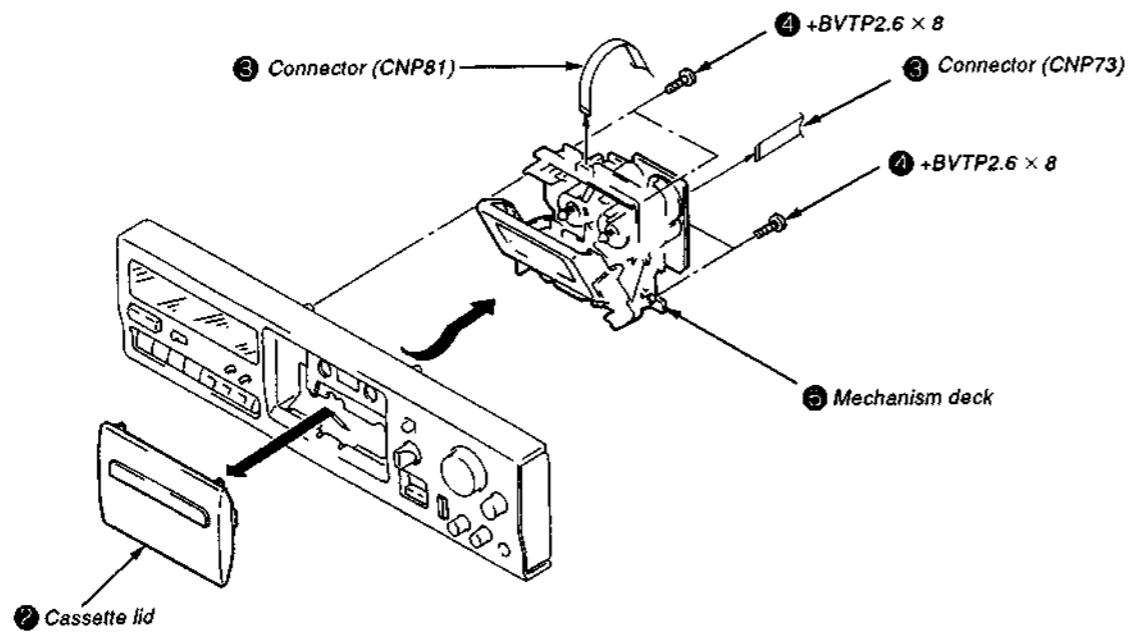

2-3. HEAD

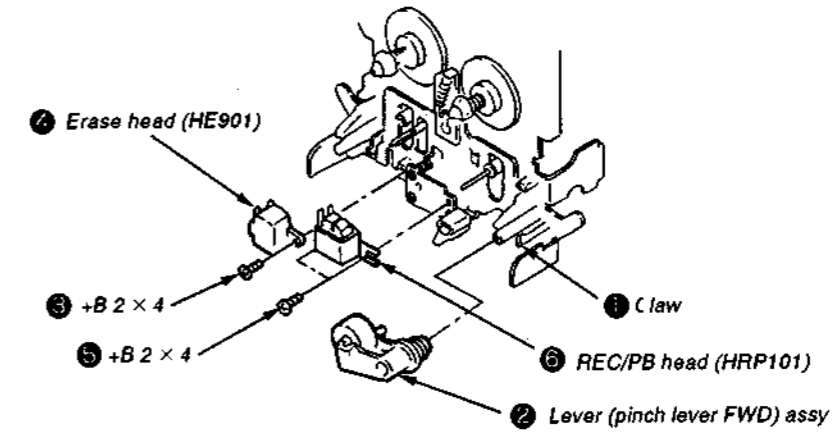

2-4. FITTING BASE BLOCK

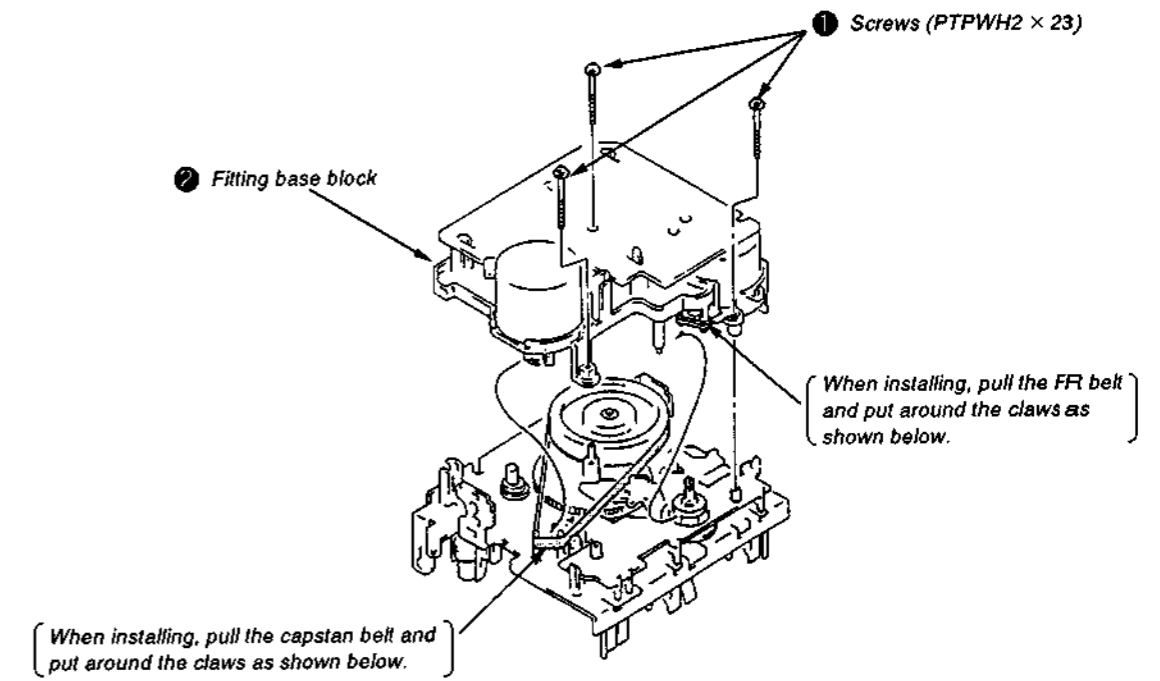

2-5. MOTOR

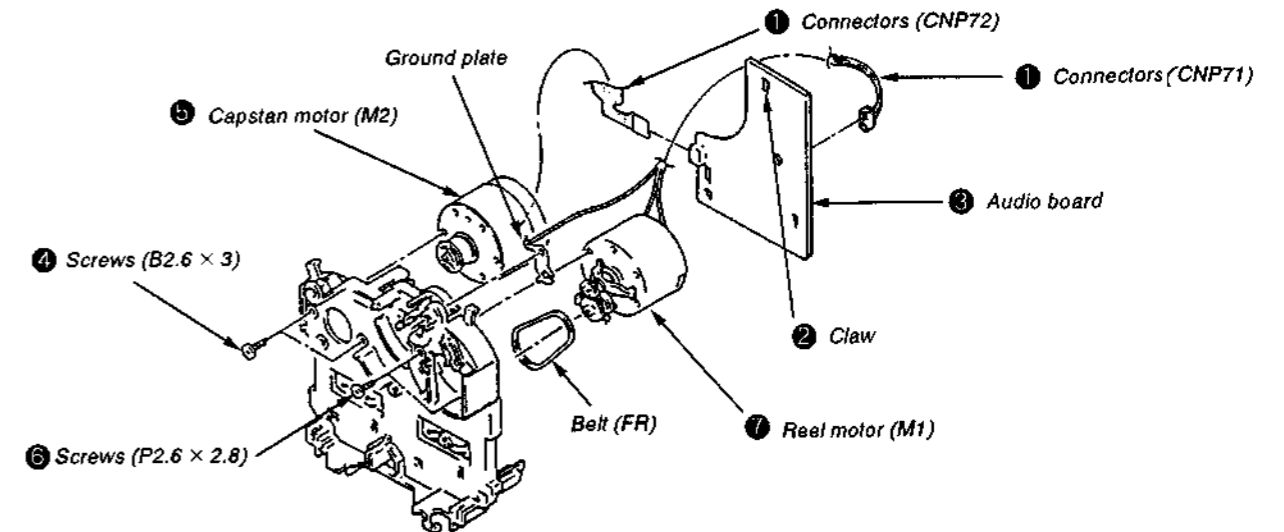

SECTION 3 EXPLANATION OF IC TERMINALS

IC801 CXP82316-018Q

Pin No.	Pin name	I/O	Description
1	TMSW	I	Test mode selector. "H" : Normal "L" : Test mode
2	SIRCS	I	Sircs signal input terminal.
3	NC	-	Not used.
4	NC	-	Not used.
5	NC	-	Not used.
6	SOURSE	I	Sourse select terminal.
7	POWER-OUT	O	Power ON/OFF.
8	POWER-IN	I	Power OFF. OFF = 0V
9	ON/OFF CAL1	I	Calibration ON/OFF control terminal.
10	H/L CAL2	I	Calibration H/L control terminal.
11	DOLBY • ON/OFF	O	Dolby ON/OFF control terminal.
12	DOLBY • B/C	O	Dolby B/C control terminal.
13	NC	-	Not used.
14	REC MUTE	O	REC out mute Terminal
15	LINE MUTE	O	Line mute ON/OFF terminal.
16	REEL -	O	Reel motor -- output terminal.
17	REEL +	O	Reel motor + output terminal.
18	C • M	O	Capstan motor. ON/OFF, ON = 0V
19	TYPE IV	I	Type IV SW input terminal.
20	TYPE II	I	Type II SW input terminal.
21	BIAS	O	Bias ON/OFF. ON=0V
22	METER-L	I	Meter level L-CH input terminal.
23	METER-R	I	Meter level R-CH input terminal.
24	HALF SW	I	Half pawl input terminal.
25	T • PULSE	I	Take up pulse input terminal.
26	S • PULSE	I	Supply pulse input terminal.
27	DOLBY	I	Dolby SW input terminal. OFF = 0V
28	KEY 1	I	Key input terminal.
29	KEY 2	I	Key input terminal.
30	RESET	I	Reset terminal. Reset : 0V
31	EXTAL	O	System clock input terminal.
32	XTAL	I	System clock output terminal.
33	V _{SS}	-	Power supply (GND)
34	S • REC • SEL	O	S • Record select terminal.
35	PB	O	Playback selector for dolby IC Select.
36	PB-S	O	Playback selector for dolby S IC select.
37	P1	O	VFD Segment.
38	P2	O	VFD Segment.
39	P6	O	VFD Segment.
40	P7	O	VFD Segment.

Pin No.	Pin name	I/O	Description
41	P3	O	VFD Segment.
42	P5	O	VFD Segment.
43	P4	O	VFD Segment.
44	P8	O	VFD Segment.
45	P16	O	VFD Segment.
46	P9	O	VFD Segment.
47	P10	O	VFD Segment.
48	P14	O	VFD Segment.
49	P15	O	VFD Segment.
50	P11	O	VFD Segment.
51	P13	O	VFD Segment.
52	P12	O	VFD Segment.
53	P27	O	VFD Segment.
54	P18	O	VFD Segment.
55	P19	O	VFD Segment.
56	P20	O	VFD Segment.
57	P25	O	VFD Segment.
58	P21	O	VFD Segment.
59	P22	O	VFD Segment.
60	P23	O	VFD Segment.
61	P24	O	VFD Segment.
62	P28	O	VFD Segment.
63	NC	-	Not used.
64	NC	-	Not used.
65	NC	-	Not used.
66	G5-MODE	O	VFD Grid.
67	G4-SEC	O	VFD Grid.
68	G3-MIN	O	VFD Grid.
69	G2-RCH	O	VFD Grid.
70	G1-LCH	O	VFD Grid.
71	- 21V	-	- 21V.
72	V _{DD}	-	Power supply (+5V)
73	-	-	In normal operation, connect to V _{DD} .
74	NC	-	Not used.
75	NC	-	Not used.
76	NC	-	Not used.
77	FILTER	O	LPF Filter control output terminal.
78	NC	-	Not used.
79	STOP SW	I	Mechanism stop switch input terminal.
80	AMS-SIG	I	AMS Signal input terminal.

SECTION 4 ADJUSTMENTS

4-1. MECHANICAL ADJUSTMENTS

PRECAUTION

- Clean the following parts with a denatured alcohol-moistened swab:

record/playback/erase head	pinch roller
rubber belts	capstan
idlers	
- Demagnetize the record/playback head with a head demagnetizer. (Head demagnetizer do not approach for the erase head.)
- Do not use a magnetized screwdriver for the adjustment.
- After the adjustments, apply suitable locking compound to the parts adjusted.
- The adjustments should be performed with the rated power supply voltage unless otherwise noted.

Torque Measurement

Torque	Torque	Meter reading
Forward	CQ-102C	30 to 65g·cm (0.42 to 0.90oz·inch)
Forward back tension	CQ-102C	1 to 6g·cm (0.014 to 0.08 oz·inch)
FF/REW	CQ-201B	70 to 120g·cm (0.98 to 1.66 oz·inch)

Record/Playback Head Height/Declination Adjustment Procedures :

- Test cassette : CQ-009C
- Insert the mirror cassette and put the unit in record/Playback mode.
 - Height Adjustment :
Check to see if the tape is curling at the tape guide of the head. If it is curling, tighten screws **A**, **B** and **C**, respectively by the same angle, moving the head so that it remains at the same angle throughout the procedure. If it curls on the bottom side of the mirror cassette (actually the inner side), tighten all the screws equally ; but loosen them if the tape begins to curl on the top side (outer side).

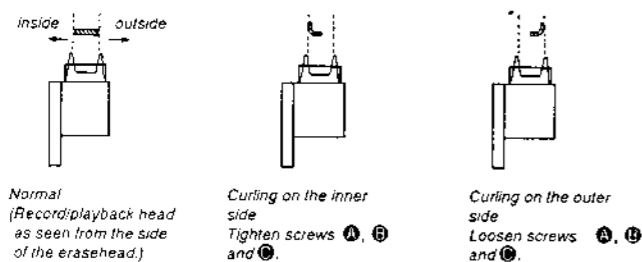

- Declination Adjustment :
While in the record/playback position, set the back tension to 0 (wind the supply reel with something thin like a pencil in a counterclockwise direction) and make sure there is no curling or shifting (shifting up/shifting down) at the guide of the record/playback head.
Because shifting can only occur due to a difference in the width of the tape and that of the tape guides (curling will otherwise occur), it is necessary to pay close attention since it can be easily overlooked.
When there is a shift, tighten screws **B** and **C** equally and change the declination of the head. If the tape is shifting up, tighten the screws, and if it is shifting down, loosen them.

Repeat the adjustments in steps 1) to 2) and fine adjust the height and the declination.

Adjustment Location : - record/playback head -

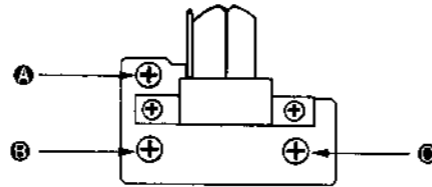

4-2. ELECTRICAL ADJUSTMENTS

PRECAUTION

- The adjustment should be performed in the publication. (Be sure to make playback adjustment at first.)
- The adjustments and measurement should be performed for both L-CH and R-CH.
 - Switch position
DOLBY NR switch : OFF
 - Standard record position:
Deliver the standard input signal level to input jack and set the REC LEVEL control to obtain the standard output signal level as follows.

- Record Mode -

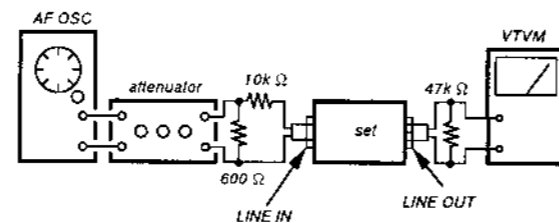

Standard Input Level

Input terminal	LINE IN
source impedance	10k Ω
input signal level	0.5V (- 3.8dB)

Standard Output Level

Output terminal	LINE OUT
load impedance	47k Ω
output signal level	0.5V (- 3.8dB)

Test Tape

Tape	Contents	Use
P-4-A100	10kHz, -10dB	Azimuth Adjustment
P-4-L300	315Hz, 0dB	PB Level Adjustment
WS-48B	3kHz, 0dB	Tape Speed Adjustment

0dB=0.775V

Test Mode

- Insert a short-circuit plug into TP801 (2P) and turn ON the power switch. (Earth pin **Ⓣ** of IC801 and turn ON the power switch.)
At first, all the fluorescent tubes light up, then the system returns to normal display. (However, "0000" is not displayed on the counter.)
- To release the test mode, remove the short plug and turn off the power switch.
- Remove the short plug after completion of adjustment.

Record/Playback Head Azimuth Adjustment Procedure :

- Forward playback Mode

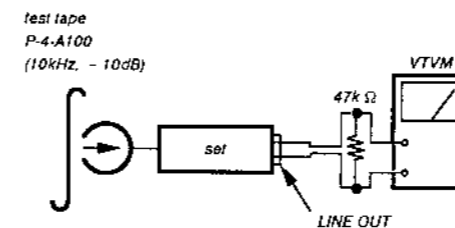

- Turn the adjustment screw for the maximum output levels. If these levels do not match, turn the adjustment screw until both of output levels match together within 1dB.

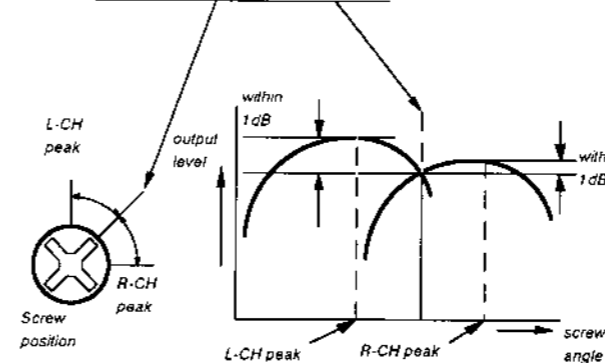

- Phase check
Playback Mode

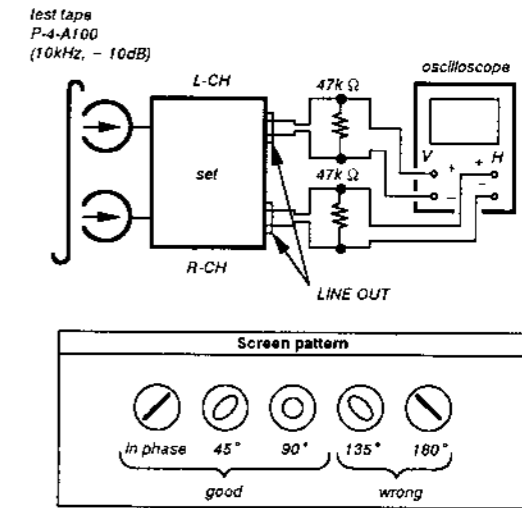

- After the adjustment, lock the adjustment screws with suitable locking compound.

Adjustment Location : - record/playback head -

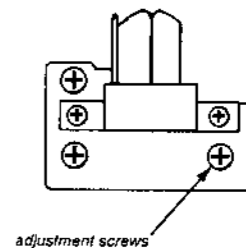

Tape Speed Adjustment

- Procedure :
- Forward Playback Mode -

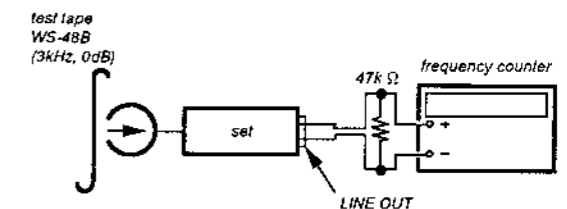

- Set to FWD playback mode.
- Adjust RV71 so that the frequency counter reading becomes $3,000 \pm 15\text{Hz}$.

Frequency difference between the beginning and the end of the tape should be within 3%.

Adjustment Location : AUDIO board

3. Phase check
Playback Mode

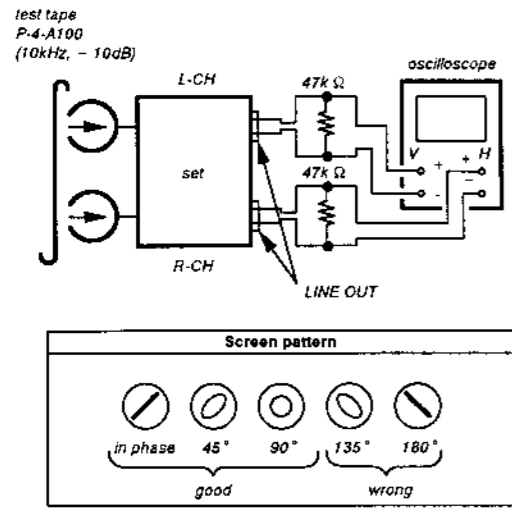

4. After the adjustment, lock the adjustment screws with suitable locking compound.

Adjustment Location : - record/playback head -

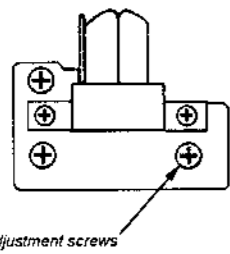

Tape Speed Adjustment

Procedure :
- Forward Playback Mode -

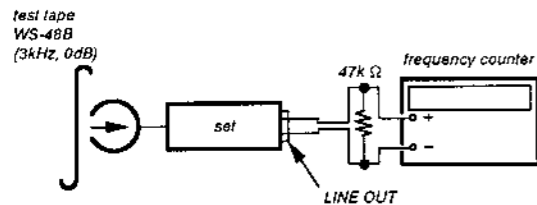

1. Set to FWD playback mode.
2. Adjust RV71 so that the frequency counter reading becomes $3,000 \pm 15\text{Hz}$.

Frequency difference between the beginning and the end of the tape should be within 3%.

Adjustment Location : AUDIO board

Playback Level Adjustment

Procedure :
- Forward Playback Mode -

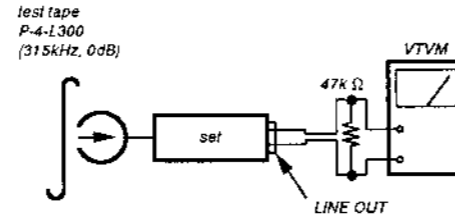

Adjust RV121 (L-CH) and RV221 (R-CH) so the VTVM reading becomes the adjustment limits below.

Adjustment Value :
LINE OUT level : $-7.7 \pm 0.5\text{dB}$ (0.301 to 0.338V)

Level difference between channels : within 0.5dB

Confirm the LINE OUT level does not change in playback mode while changing the mode from playback to stop several times

Adjustment Location : MAIN board

Bias Consumption Current Adjustment

This adjustment should be performed when replacing the head assy or the bias oscillating transformer (T101, T201).

Procedure :
() : R-CH

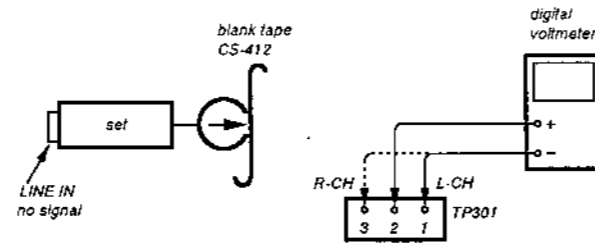

1. Connect the digital voltmeter to test point TP301.
2. Set RV103 (RV203) to mechanical center.
3. Set to FWD record mode.
4. Adjust T101 (T201) so that the digital voltmeter reading becomes minimum.

Adjustment Location : MAIN board

Record Level Adjustment

Setting :
REC LEVEL control : standard record position (Refer to page 9.)

Procedure :
1. Record Mode

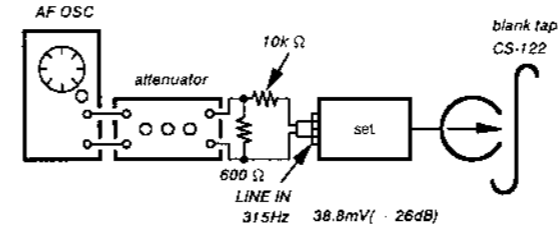

2. Playback Mode

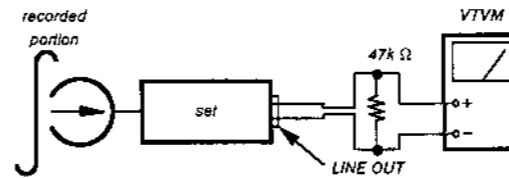

Confirm playback the tape recorded become adjustment level as follows.

If necessary, adjust RV101 (L-CH), RV201 (R-CH) and repeat the steps 1 and 2.

Adjustment Value :
LINE OUT level : $-26 \pm 0.5\text{dB}$ (36.7 to 41.1mV)

Adjustment Location : MAIN board

Record Bias Adjustment

Setting :
REC LEVEL control : standard record position (Refer to page 9.)

Procedure :
1. Record Mode

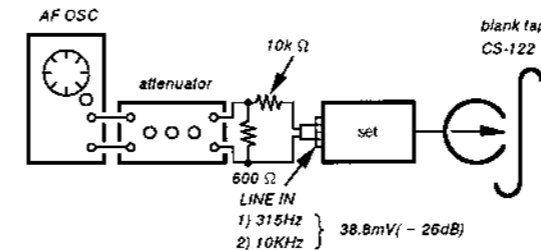

2. Playback Mode

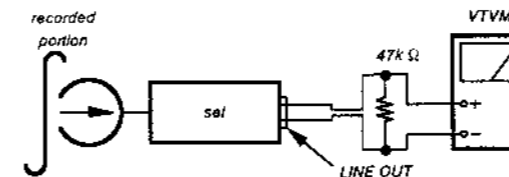

Confirm that the 10kHz playback output is $0 \pm 0.3\text{dB}$ relative to the 315Hz output. If necessary, adjust RV103 (L-CH), RV203 (R-CH) and repeat the steps given above.

Adjustment Location : MAIN board

Record EQ (IV) Adjustment

Setting :
REC LEVEL control : standard record position (Refer to page 9.)

Procedure :
1. Record Mode

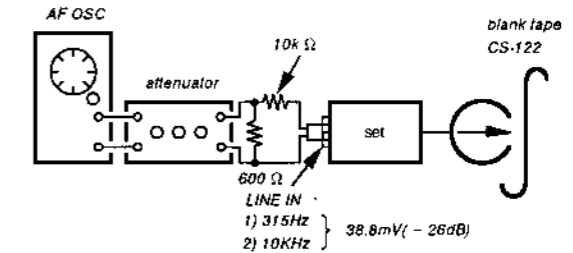

2. Playback Mode

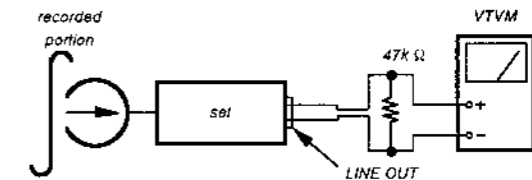

1. Adjust RV102 and 202 so that they become maximum.
2. Adjust RV102 (L-CH) and 202(R-CH) so that the difference between R-CH and L-CH at 10 kHz is within 1dB.
3. Adjust RV306 so that the value of R-CH becomes the specified value.

Specified value :
(the level at 10kHz against to 315Hz : $0\text{dB} \pm 1\text{dB}$)

Adjustment Location : MAIN board

- Adjustment Parts Location Diagrams -

[MAIN BOARD]
(Component Side)

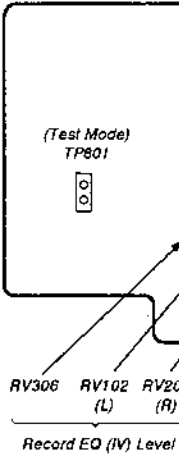

[AUDIO BOARD]
(Component Side)



Record Level Adjustment

Setting :

REC LEVEL control : standard record position (Refer to page 9.)

Procedure :

1. Record Mode

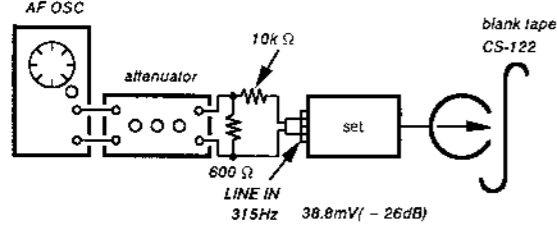

2. Playback Mode

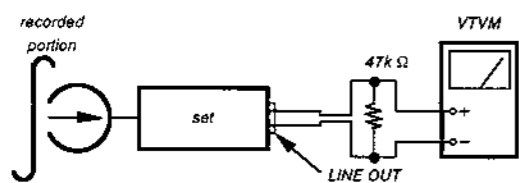

Confirm playback the tape recorded become adjustment level as follows.

If necessary, adjust RV101 (L-CH), RV201 (R-CH) and repeat the steps 1 and 2.

Adjustment Value :

LINE OUT level : $-26 \pm 0.5\text{dB}$ (36.7 to 41.1mV)

Adjustment Location : MAIN board

Record Bias Adjustment

Setting :

REC LEVEL control : standard record position (Refer to page 9.)

Procedure :

1. Record Mode

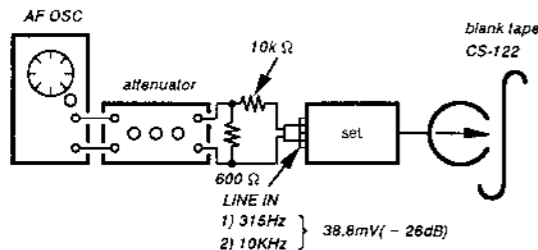

2. Playback Mode

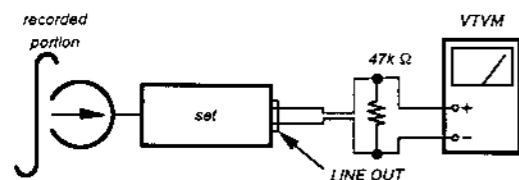

Confirm that the 10kHz playback output is $0 \pm 0.3\text{dB}$ relative to the 315Hz output. If necessary, adjust RV103 (L-CH), RV203 (R-CH) and repeat the steps given above.

Adjustment Location : MAIN board

Record EQ (IV) Adjustment

Setting :

REC LEVEL control : standard record position (Refer to page 9.)

Procedure :

1. Record Mode

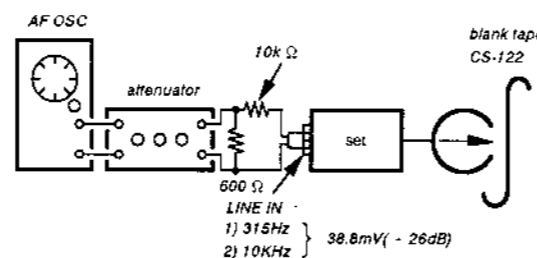

2. Playback Mode

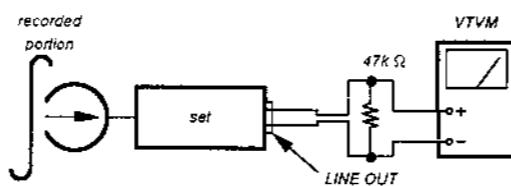

1. Adjust RV102 and 202 so that they become maximum.
2. Adjust RV102 (L-CH) and 202(R-CH) so that the difference between R-CH and L-CH at 10 kHz is within 1dB.
3. Adjust RV306 so that the value of R-CH becomes the specified value.

Specified value :

(the level at 10kHz against to 315Hz : $0\text{dB} \pm 1\text{dB}$)

Adjustment Location : MAIN board

— Adjustment Parts Location Diagrams —

[MAIN BOARD]

(Component Side)

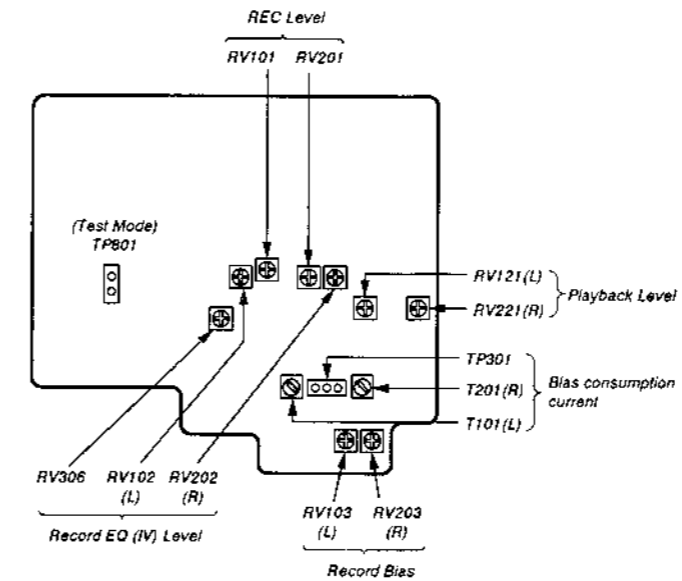

[AUDIO BOARD]

(Component Side)

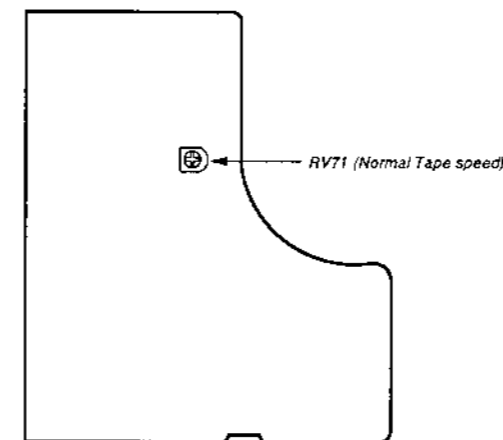

SECTION 5
DIAGRAMS

5-1. CIRCUIT BOARDS LOCATION

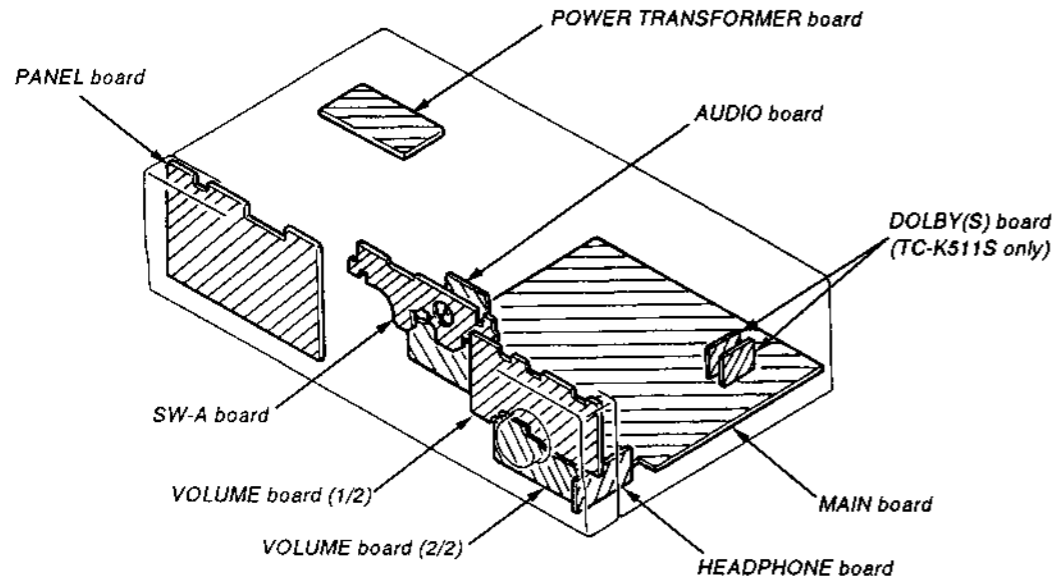

• SEMICONDUCTOR LEAD LAYOUTS

LA6500-FA

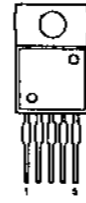

2SA473
2SD1585-K
2SD2012



PST600E

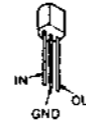

2SB1013-4
2SB1116A-L
2SC945-P



SBX1610-59



HZS6A1L
HZS7C1L
UZL-7L2
UZL-7H1

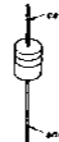

BN1L3Z-K
DTC144ES
2SA1175-HFE
2SC2785-HFE



IN4148M
10E2N



DTA114ES
DTC114ES
DTC143TS
2SC2603-EF
2SD2144S

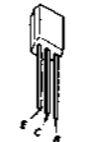

NJL5165K-B

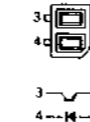

• SEMICONDUCTOR LOCATION

Ref. No.	Location	Ref. No.	Location
D101	B - 14	IC801	F - 16
D102	B - 14	IC802	F - 14
D201	C - 13	IC803	H - 16
D202	C - 13	IC901	G - 19
D301	B - 9		
D302	B - 9	Q101	G - 9
D303	B - 9	Q102	C - 13
D304	B - 9	Q103	C - 10
D305	D - 14	Q104	G - 11
D306	H - 13	Q105	F - 12
D307	G - 13	Q201	G - 8
D308	G - 13	Q202	B - 10
D310	F - 12	Q203	C - 10
D311	B - 12	Q204	G - 10
D312	B - 12	Q205	F - 11
D313	C - 13	Q301	D - 14
D314	F - 13	Q302	H - 12
D701	C - 16	Q303	H - 12
D702	C - 16	Q304	H - 12
D703	C - 16	Q305	I - 12
D704	C - 16	Q306	I - 12
D705	C - 15	Q307	J - 12
D706	B - 16	Q308	J - 12
D707	C - 16	Q309	J - 12
D708	C - 16	Q310	H - 12
D709	D - 15	Q311	H - 12
D711	B - 17	Q312	B - 11
D712	B - 17	Q313	B - 13
D713	D - 17	Q314	B - 13
D714	D - 17	Q315	D - 12
D715	D - 17	Q701	E - 15
D718	C - 17	Q702	C - 15
D801	F - 14	Q703	A - 15
D802	F - 13	Q704	A - 16
D803	F - 13	Q705	A - 17
D806	G - 15	Q706	B - 17
D814	G - 13	Q707	B - 17
D815	G - 13	Q708	C - 17
		Q709	D - 17
		Q801	G - 15
IC81	K - 20	Q802	F - 14
IC82	K - 18	Q803	G - 15
IC301	H - 9	Q804	G - 15
IC302	C - 11	Q805	G - 15
IC303	G - 10	Q806	G - 15
IC304	I - 10		
IC305	D - 14	Q807	F - 15
IC306	C - 14	Q808	E - 15
IC307	F - 9	Q809	E - 15
IC308	B - 11	Q810	G - 14
		Q813	E - 14
IC309	B - 13		
IC310	D - 9	Q814	E - 14
IC311	E - 11	Q815	E - 16
IC312	C - 9		
IC701	B - 15		

Note:

- : parts extracted from the component side.
- : parts mounted on the conductor side.
- ▨ : Pattern on the side which is seen.
- G : Germany
- AUS : Australian

5-2. PRINTED WIRING BOARDS (MAIN SECTION)

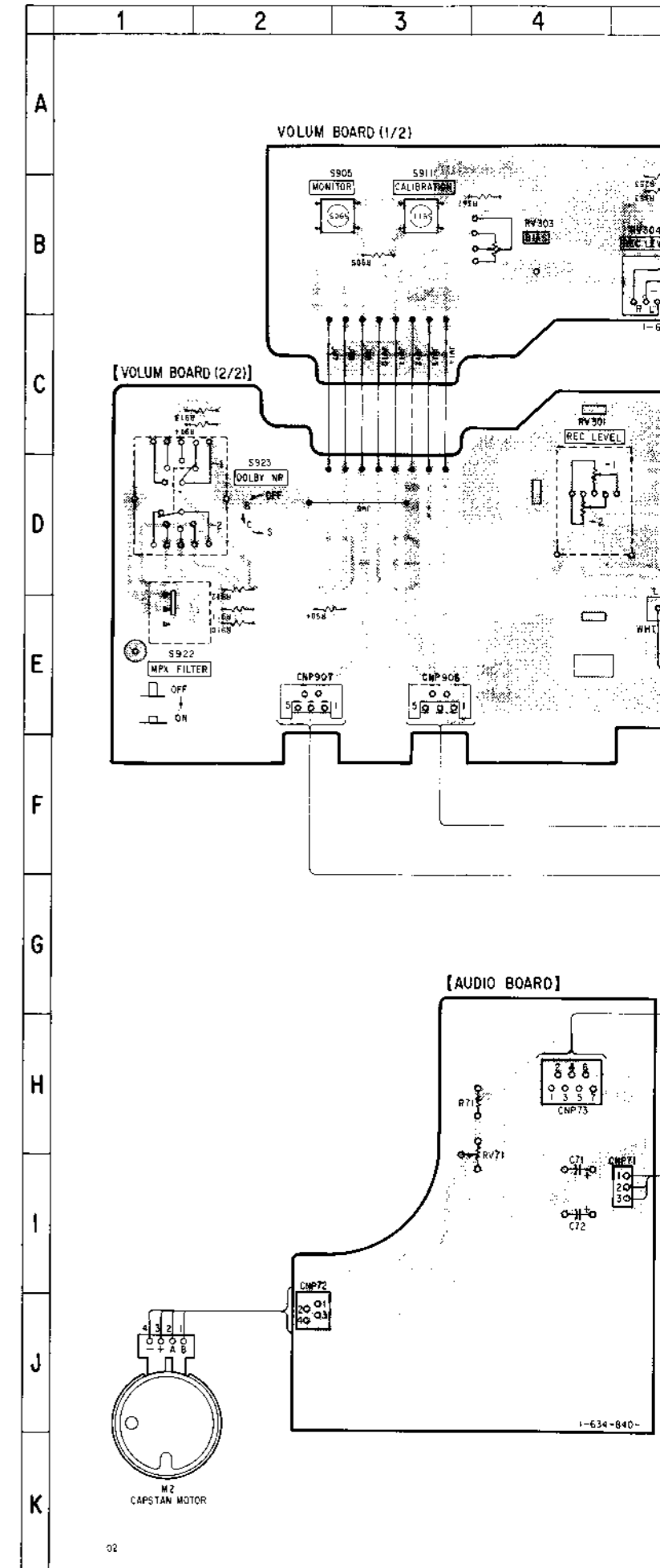

CONDUCTOR LOCATION

Location	Ref. No.	Location
B-14	IC801	F-16
B-14	IC802	F-14
C-13	IC803	H-16
C-13	IC901	G-19
B-9		
B-9	Q101	G-9
B-9	Q102	C-13
B-9	Q103	C-10
D-14	Q104	G-11
H-13	Q105	F-12
G-13	Q201	G-8
G-13	Q202	B-10
F-12	Q203	C-10
B-12	Q204	G-10
B-12	Q205	F-11
C-13	Q301	D-14
F-13	Q302	H-12
C-16	Q303	H-12
C-16	Q304	H-12
C-16	Q305	I-12
C-16	Q306	I-12
C-15	Q307	J-12
B-16	Q308	J-12
C-16	Q309	J-12
C-16	Q310	H-12
D-15	Q311	H-12
B-17	Q312	B-11
B-17	Q313	B-13
D-17	Q314	B-13
D-17	Q315	D-12
D-17	Q701	E-15
C-17	Q702	C-15
F-14	Q703	A-15
F-13	Q704	A-16
F-13	Q705	A-17
G-15	Q706	B-17
G-13	Q707	B-17
G-13	Q708	C-17
	Q709	D-17
	Q801	G-15
K-20	Q802	F-14
H-9	Q803	G-15
C-11	Q804	G-15
G-10	Q805	G-15
	Q806	G-15
I-10		
D-14	Q807	F-15
C-14	Q808	E-15
F-9	Q809	E-15
B-11	Q810	G-14
	Q813	E-14
B-13		
D-9	Q814	E-14
E-11	Q815	E-16
C-9		
B-15		

5-2. PRINTED WIRING BOARDS (MAIN SECTION)

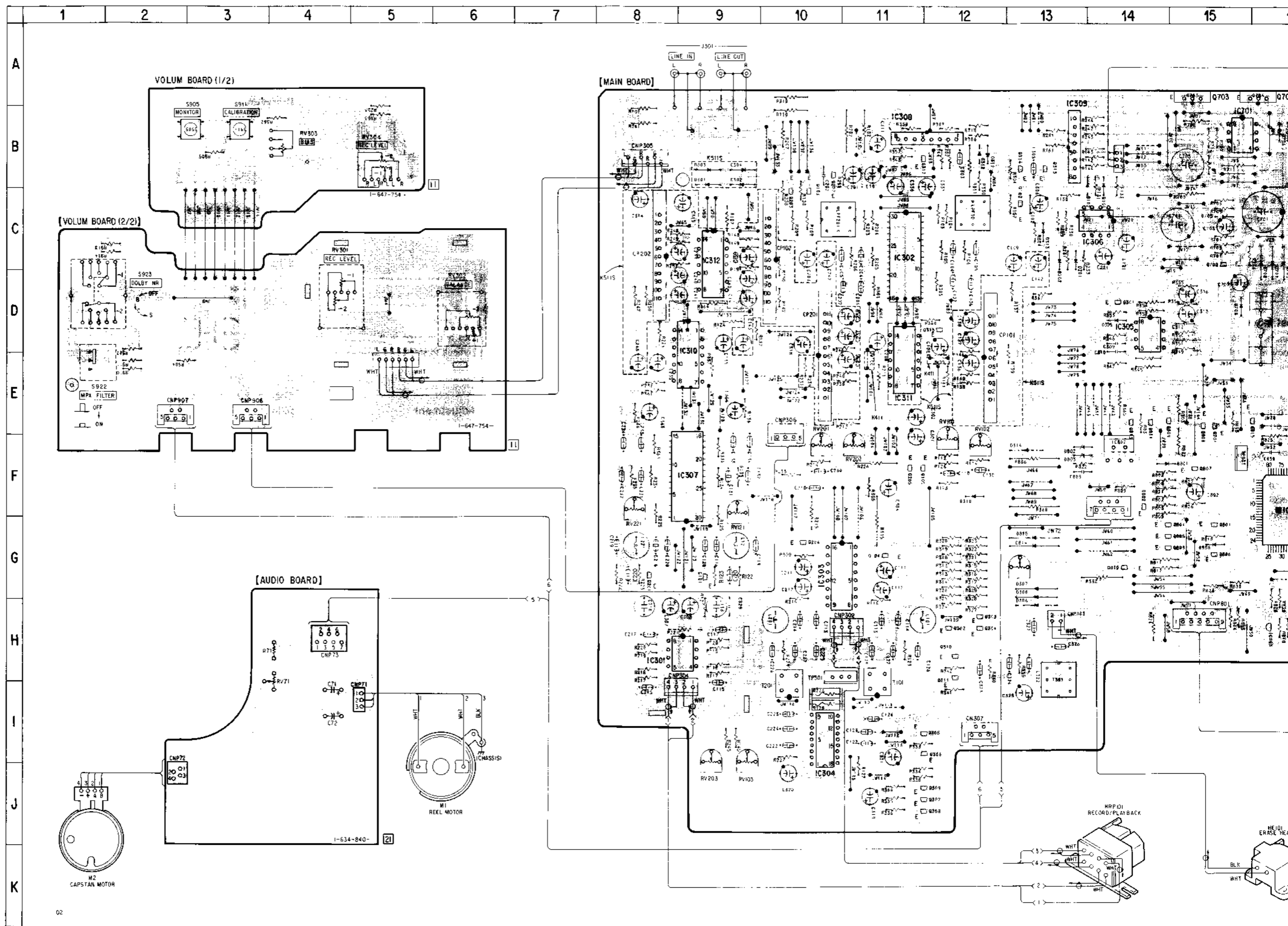

Note:
 ○ : parts extracted from the component side.
 ■ : parts mounted on the conductor side.
 ▨ : Pattern on the side which is seen.

GER : Germany
 AUS : Australian

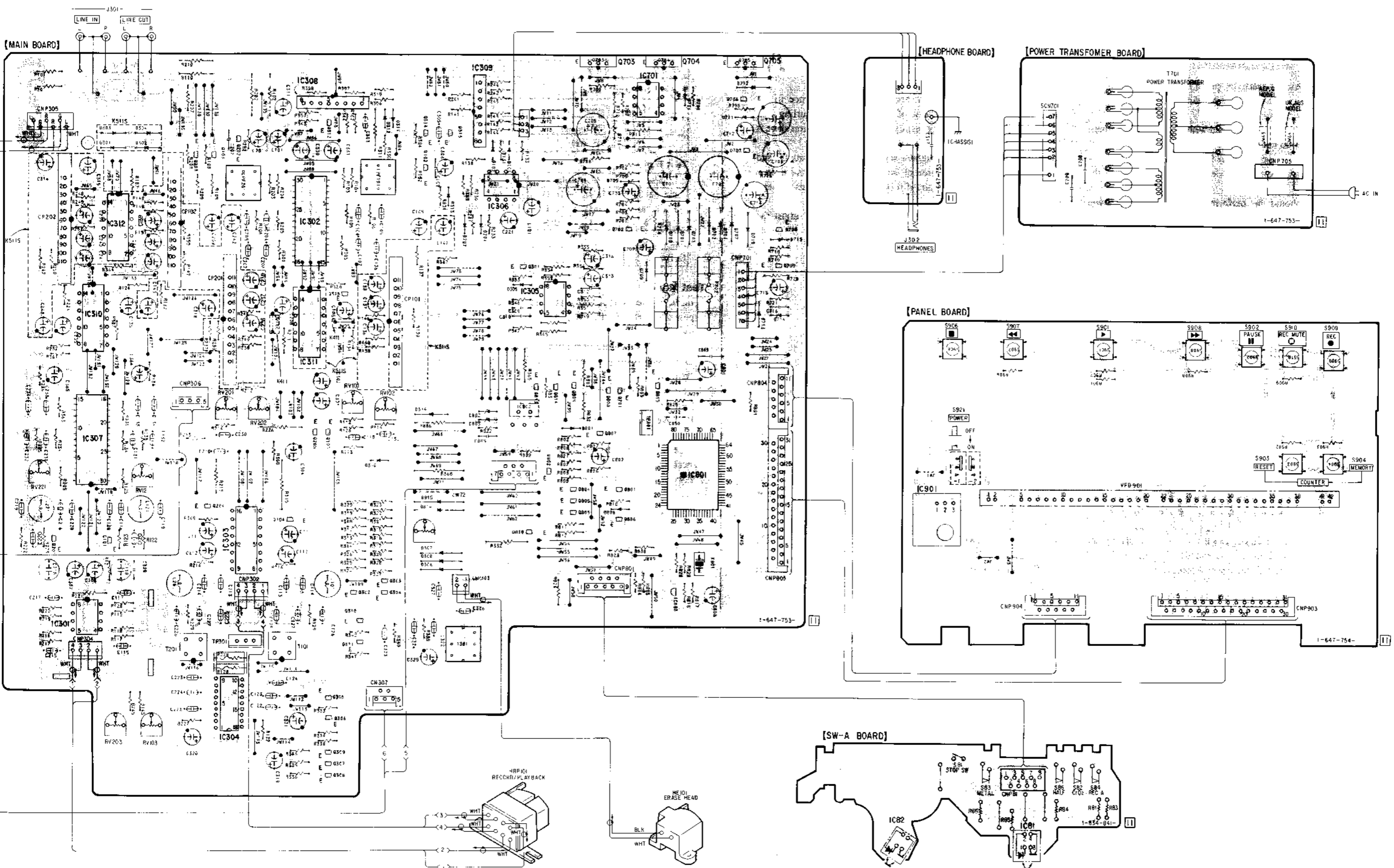

5-3. SCHEMATIC DIAGRAM (MAIN SECTION)

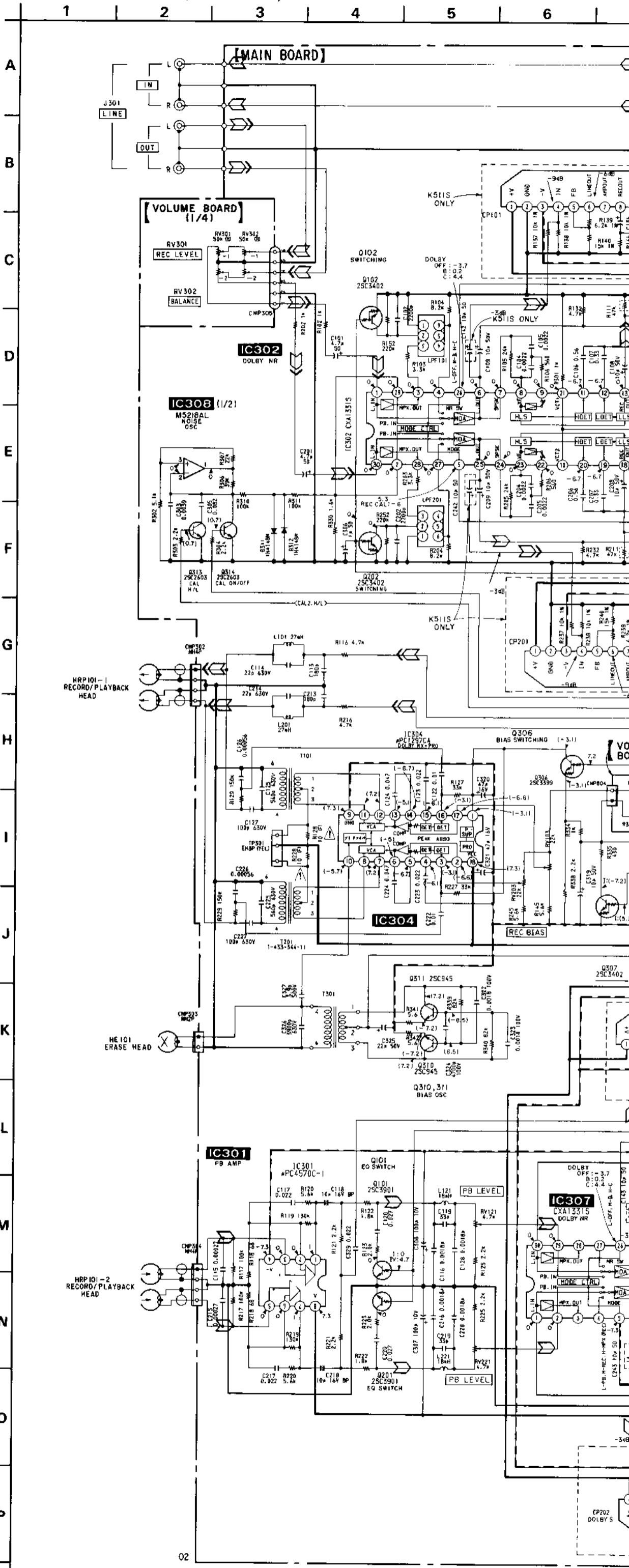

● WAVEFORMS

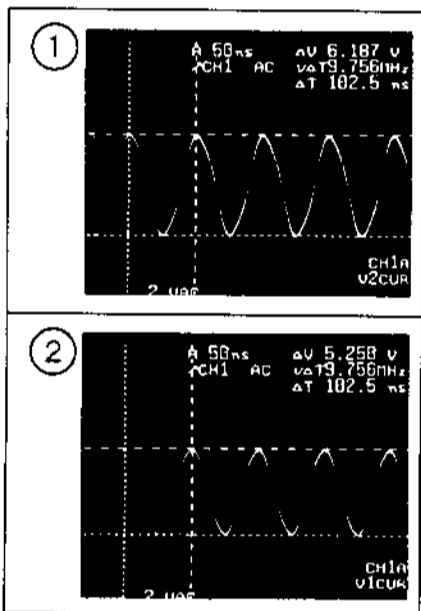

Note :

- All capacitors are in μF unless otherwise noted, pF: μF 50WV or less are not indicated except for electrolytics and tantalums.
- All resistors are in Ω and $\frac{1}{4}W$ or less unless otherwise specified.
- % : indicates tolerance.
- Δ : internal component.
- $\text{---} \text{---}$: fusible resistor.

Note : The components identified by mark Δ or dotted line with mark Δ are critical for safety. Replace only with part number specified.

- --- : B+ Line
- --- : adjustment for repair.
- Voltage and waveforms are dc with respect to ground under no-signal conditions.
- no mark : STOP
- () : REC
- Voltagcs are taken with a VOM (Input impedance 10M Ω). Voltage variations may be noted due to normal production tolerances.
- Waveforms are taken with a oscilloscope. Voltage variations may be noted due to normal production tolerances.
- Circled numbers refer to waveforms.
- Signal path.
- --- : PB
- --- : REC
- G : Germany
- AUS : Australian

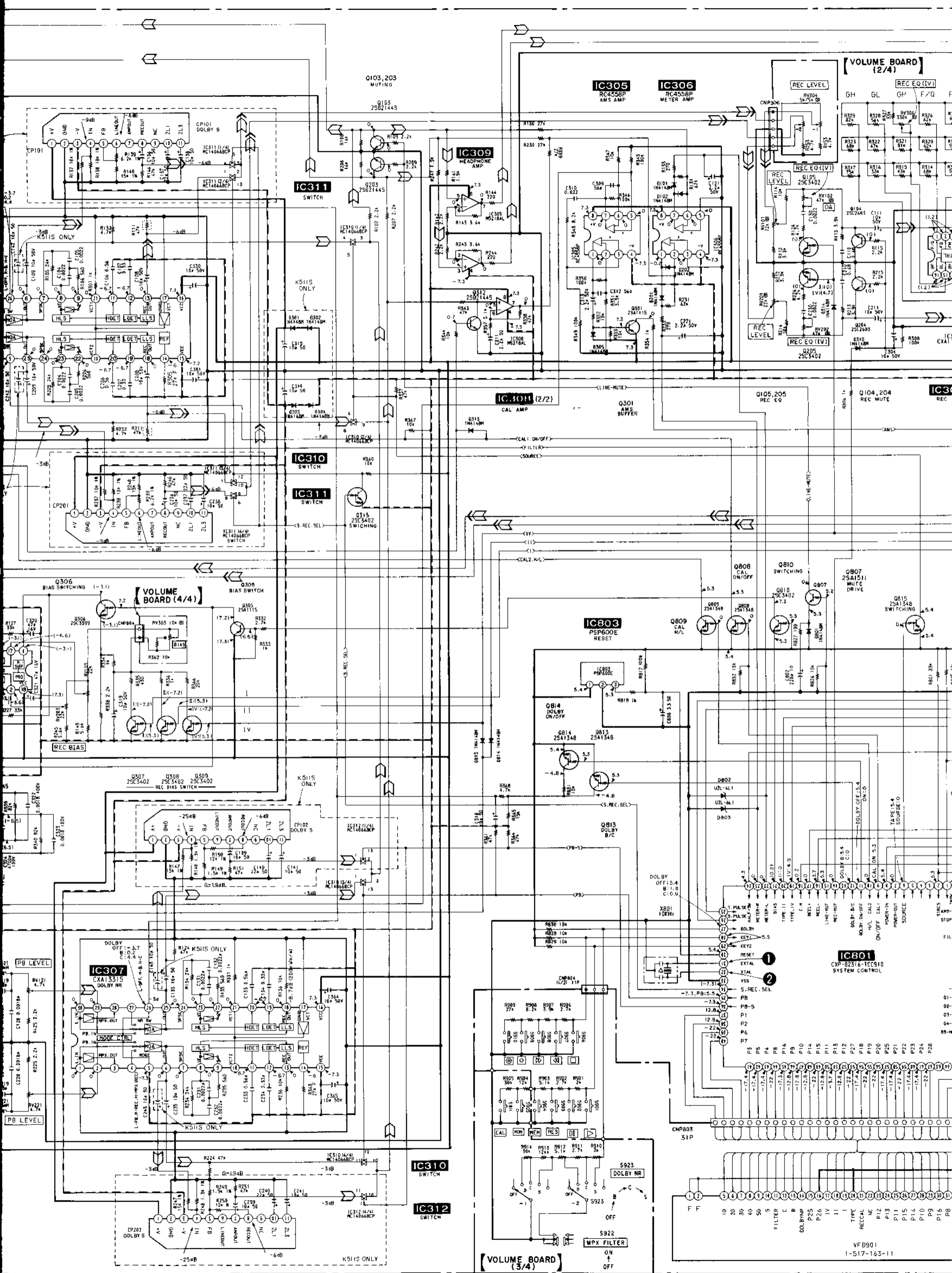

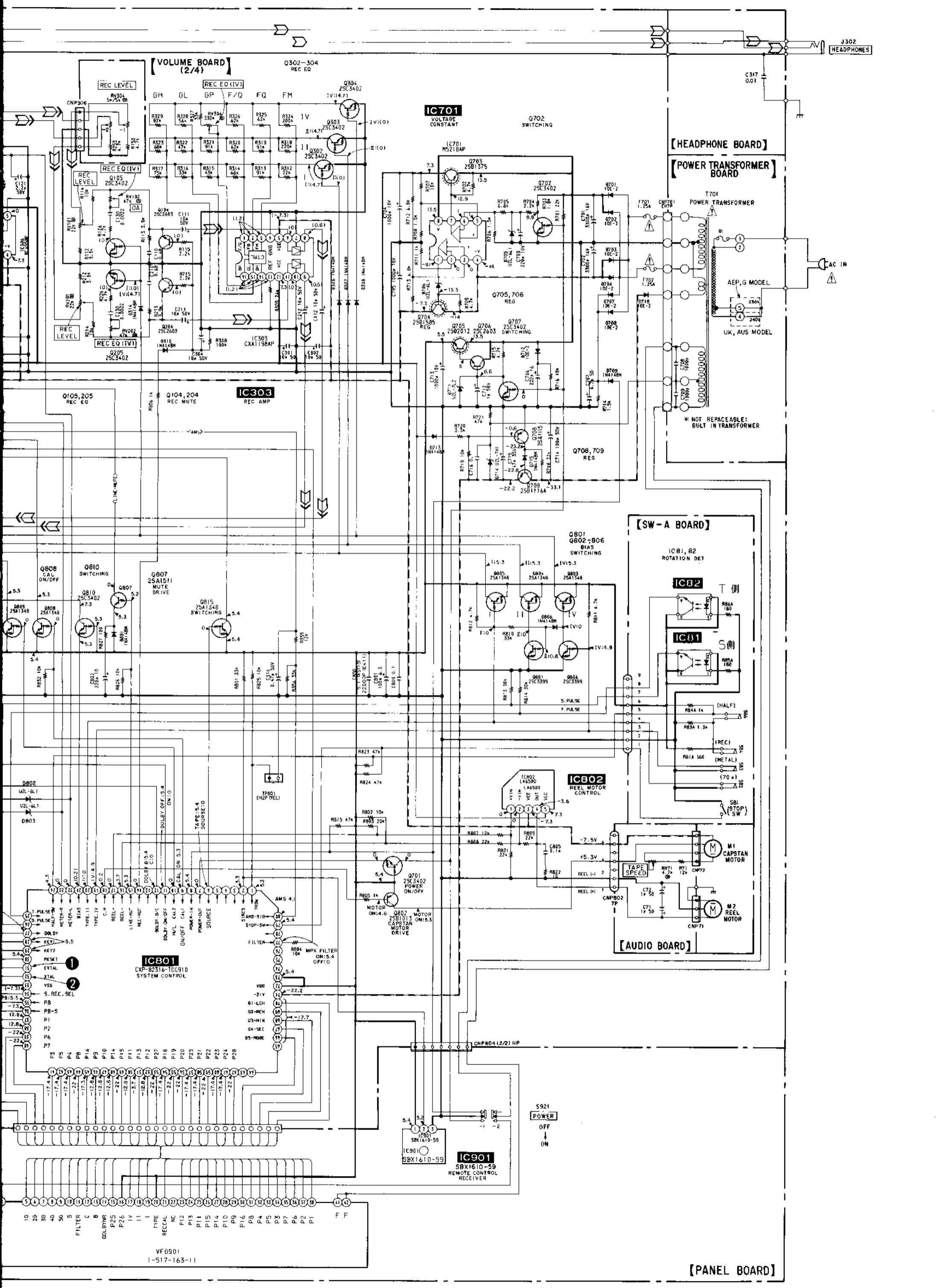

[VOLUME BOARD (2/4)]

[HEADPHONE BOARD]

[POWER TRANSFORMER BOARD]

[SW-A BOARD]

[AUDIO BOARD]

[PANEL BOARD]

VF9901
1-517-163-11

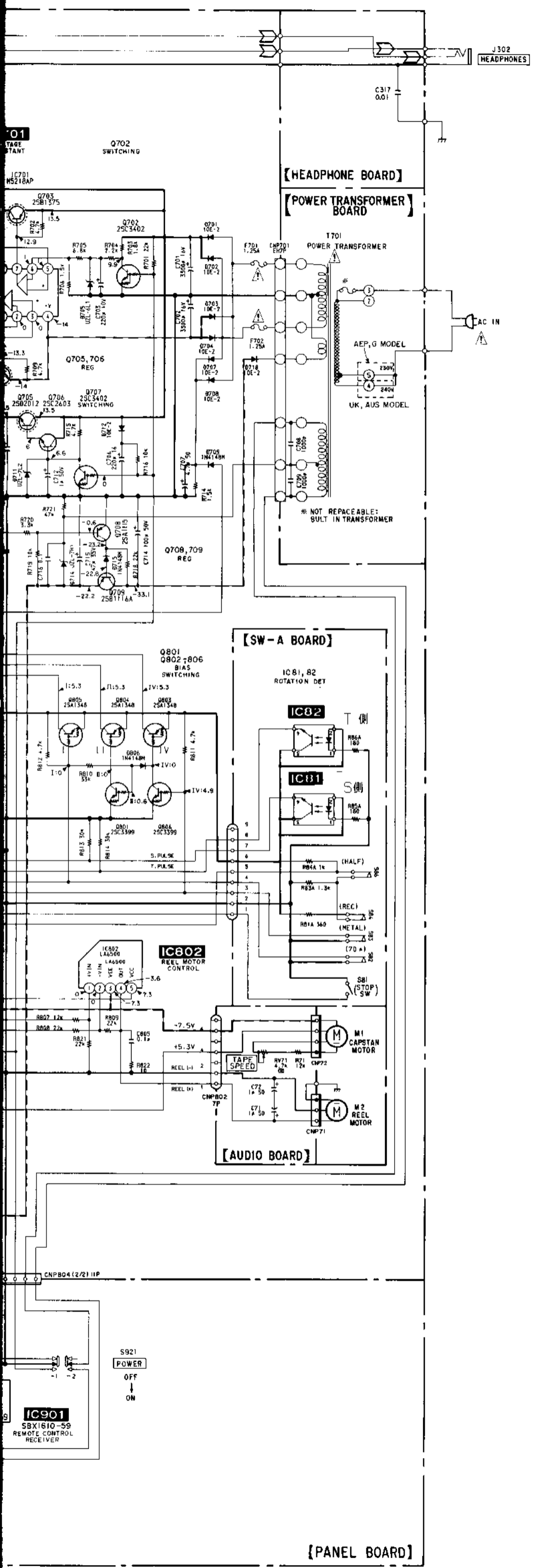

5-4. PRINTED WIRING BOARDS (DOLBY (S) BOARD)

• Refer to page 15 for Note.

5-5. SCHEMATIC DIAGR

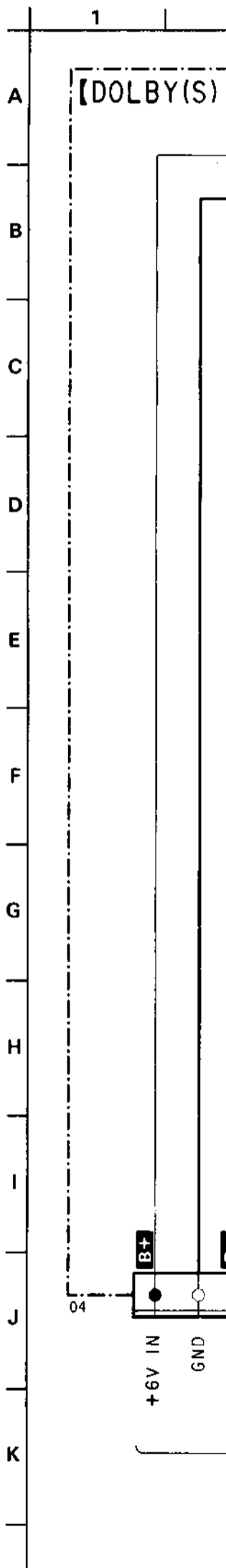
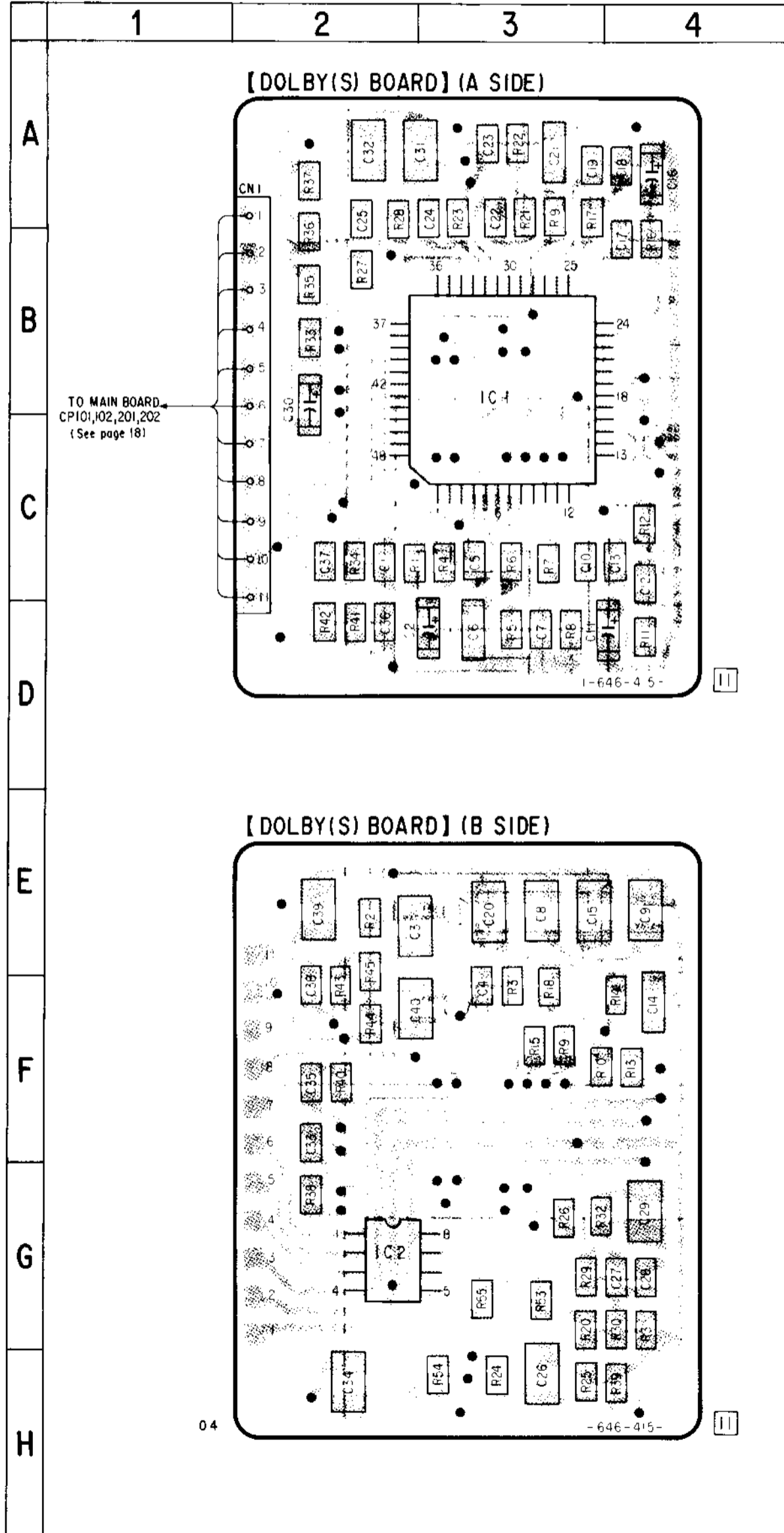

1 2 3 4 5 6 7 8 9 10 11 12

[DOLBY(S) BOARD]

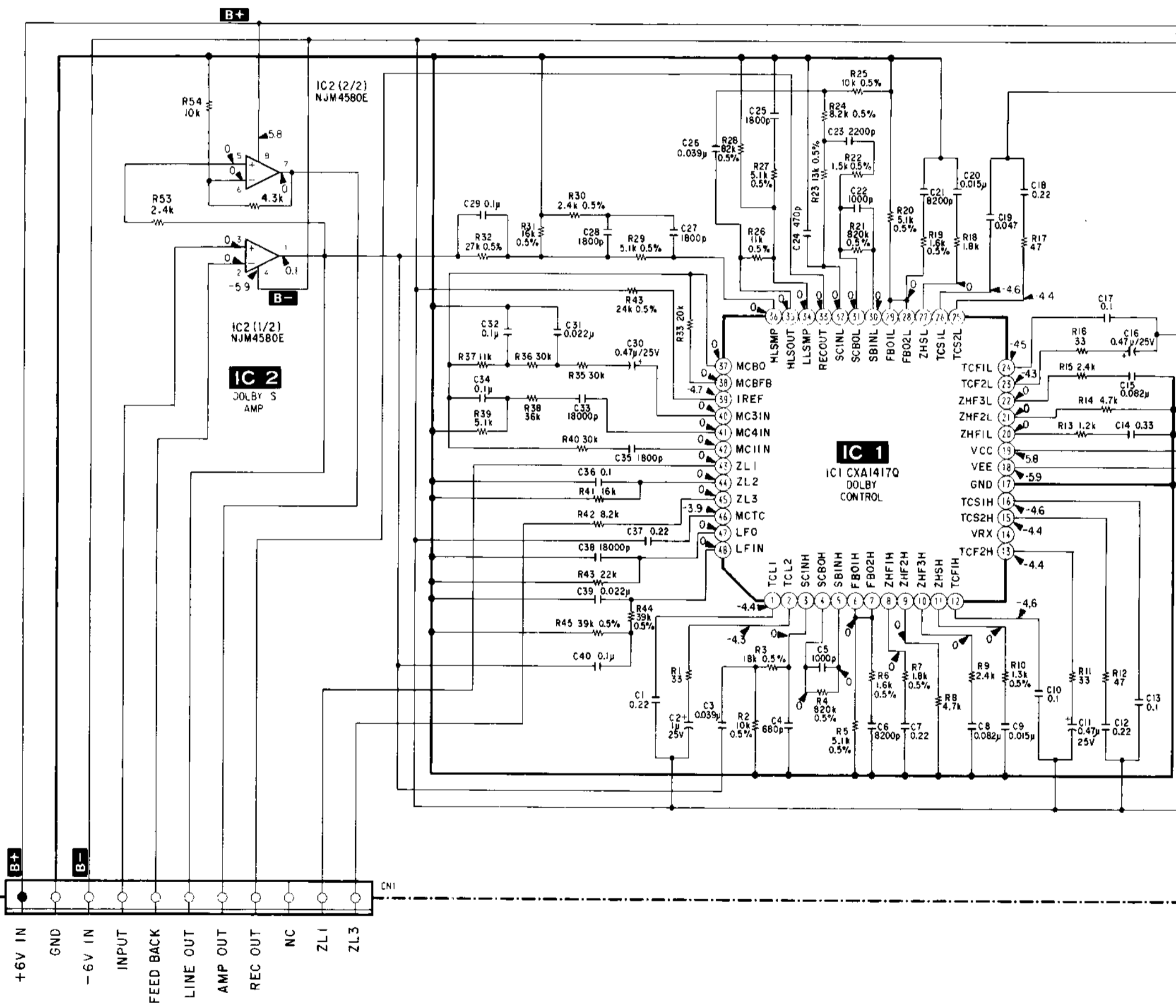

TO MAIN BOARD
CP101,102,201,202
(See page 25)

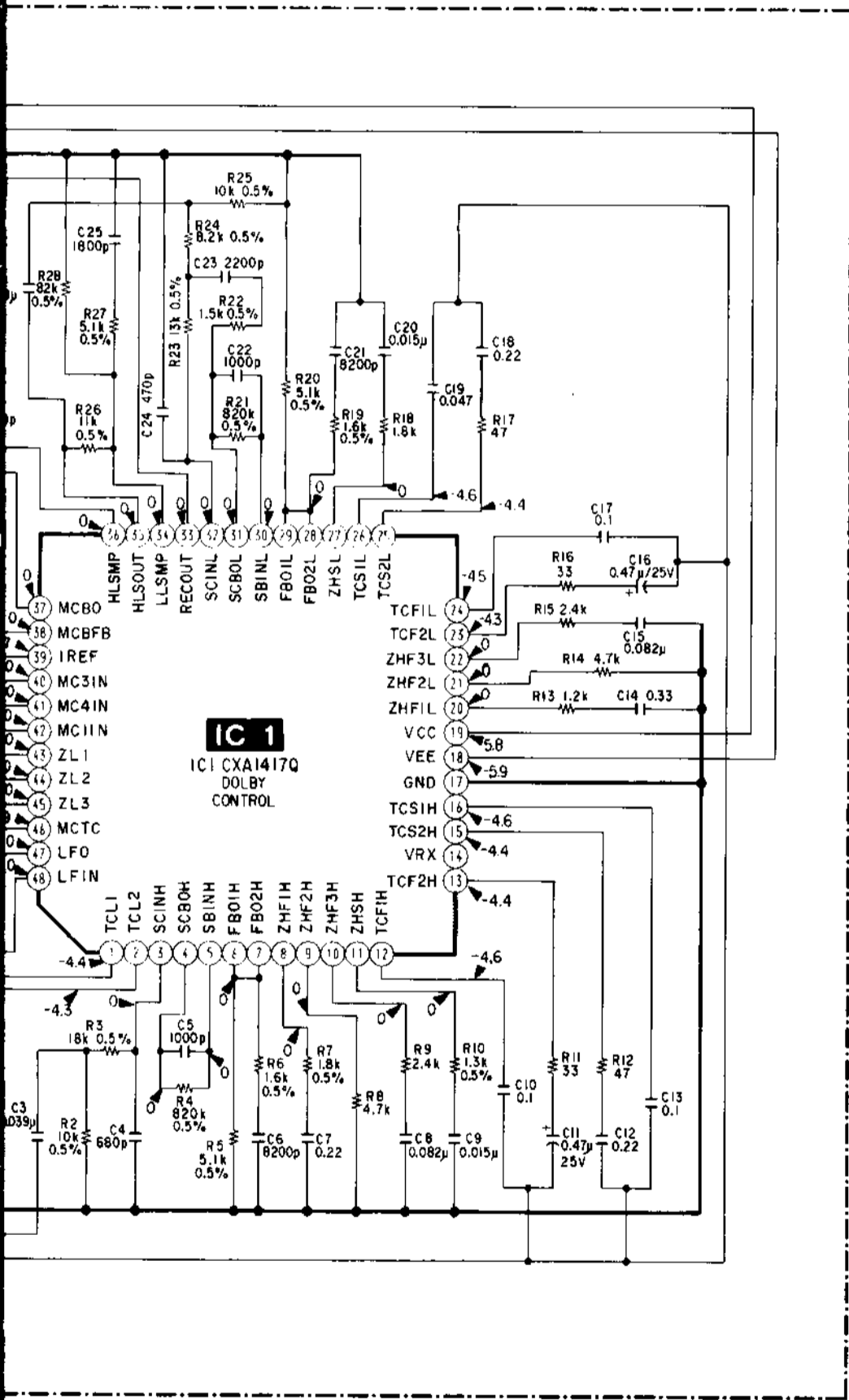

SECTION EXPLODED V

NOTE :

- -XX, -X mean standardized parts, so they may have some difference from the original one.
- The construction parts of an assembled part are indicated with a collation number in the remark column.
- Color indication of Appearance Parts
Example :
KNOB, BALANCE (WHITE)...(RED)
- Items marked " * " are not required, they are seldom required for service. Some delay should be expected when ordering these items.
- The mechanical parts with a number in the exploded view are not supplied.
- Hardware (# mark) list is at the last of this parts list.

Parts color Cabinet's color

6-1. CHASSIS SECTION

■ A : POWER TRANSFORMER board

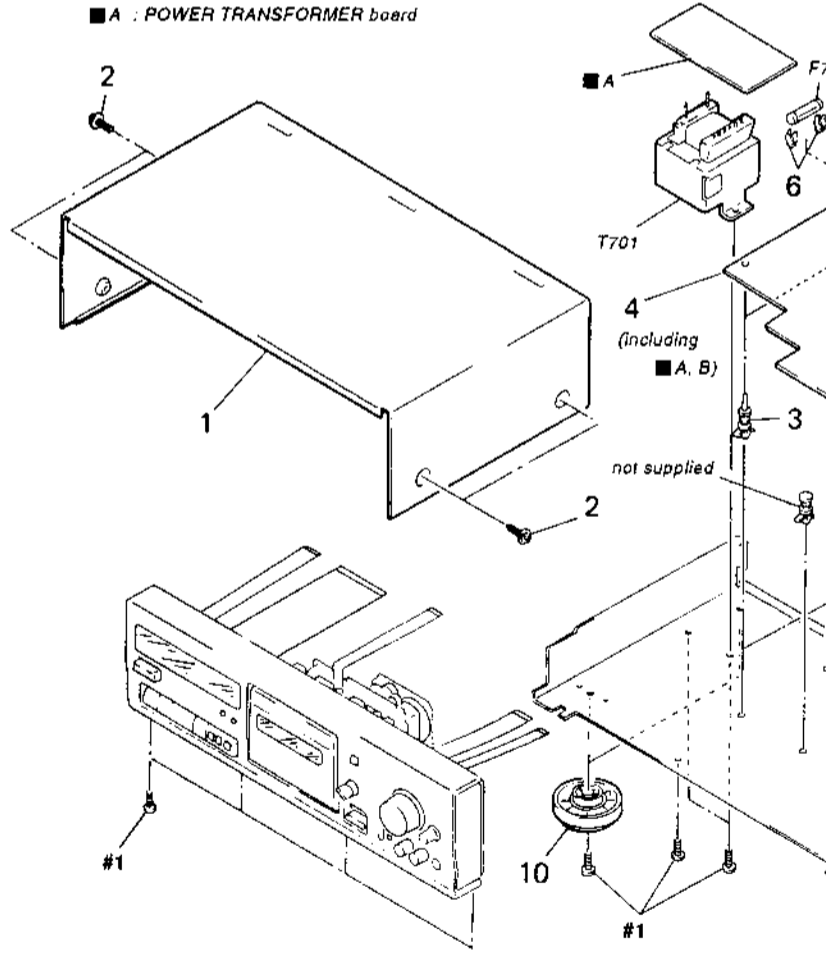

Ref. No.	Part No.	Description	Remark	Ref. No.
1	3-332-578-61	CASE		* 9
2	3-704-366-01	SCREW (CASE) (M3X8)		* 9
* 3	3-346-265-11	HOLDER, PC BOARD		10
* 4	A-2007-008-A	MAIN BOARD, COMPLETE (K411)		* 11
* 4	A-2007-009-A	MAIN BOARD, COMPLETE (K511S)		12
△5	1-575-651-21	CORD, POWER (AEP, Germany)		* 13
△5	1-696-586-11	CORD, POWER (UK)		* CN1
△5	1-696-845-11	CORD, POWER (AUS)		△F701
* 6	1-533-213-31	HOLDER, FUSE		△F702
* 7	3-703-244-00	BUSHING (2104), CORD		Q703
* 8	4-949-235-01	HOOK (AEP, Germany)		Q704
* 9	3-387-832-01	PANEL, BACK (K511S:UK, AUS)		Q705
* 9	3-387-832-11	PANEL, BACK (K511S:AEP, Germany)		△T701

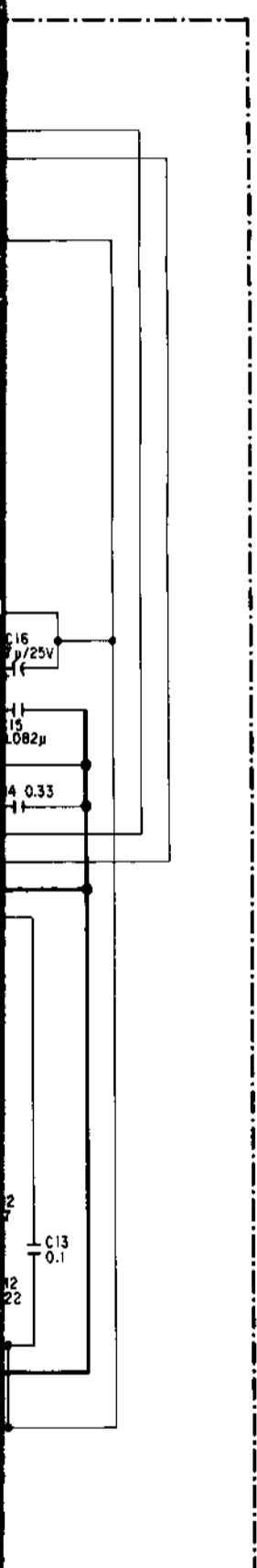

SECTION 6 EXPLODED VIEWS

NOTE:

- -XX, -X mean standardized parts, so they may have some difference from the original one.
- The construction parts of an assembled part are indicated with a collation number in the remark column.
- Color indication of Appearance Parts
Example :
KNOB, BALANCE (WHITE)...(RED)

Parts color Cabinet's color

- Items marked " * " are not stocked since they are seldom required for routine service. Some delay should be anticipated when ordering these items.
- The mechanical parts with no reference number in the exploded views are not supplied.
- Hardware (# mark) list is given in the last of this parts list.

The components identified by mark Δ or dotted line with mark Δ are critical for safety. Replace only with part number specified.

• AUS : Australian

6-1. CHASSIS SECTION

■ A : POWER TRANSFORMER board

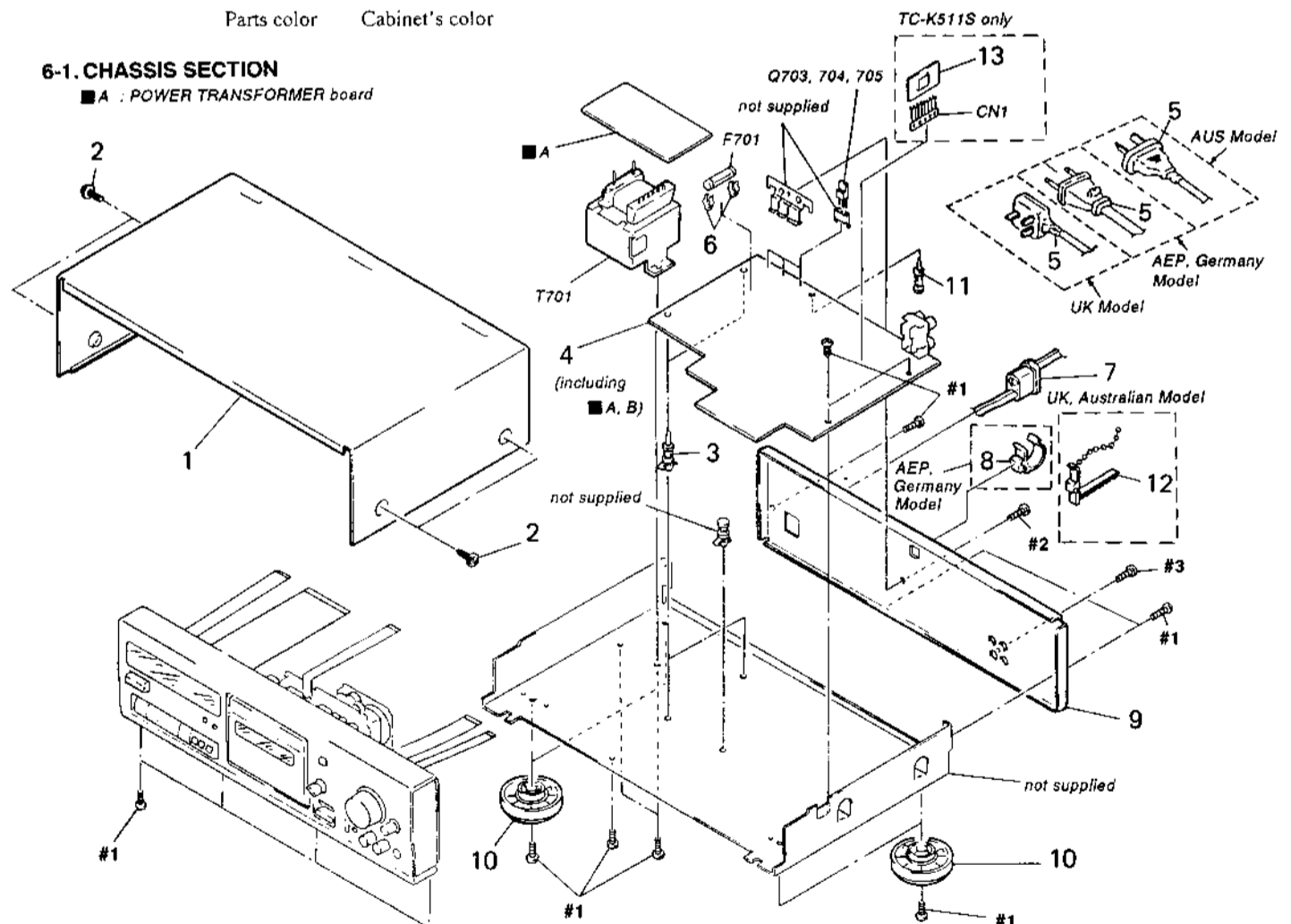

Ref. No.	Part No.	Description	Remark	Ref. No.	Part No.	Description	Remark
1	3-332-578-61	CASE		* 9	3-387-835-01	PANEL, BACK (K411:UK, AUS)	
2	3-704-366-01	SCREW (CASE) (M3X8)		* 9	3-387-835-11	PANEL, BACK (K411:AEP, Germany)	
* 3	3-346-265-11	HOLDER, PC BOARD		10	4-956-885-11	FOOT (F58175S2W)	
* 4	A-2007-008-A	MAIN BOARD, COMPLETE (K411)		* 11	3-669-610-00	SPACER	
* 4	A-2007-009-A	MAIN BOARD, COMPLETE (K511S)		12	4-956-370-02	BAND, PLUG FIXED (US, AUS)	
Δ 5	1-575-651-21	CORD, POWER (AEP, Germany)		* 13	A-2006-954-A	DOLBY(S) BOARD, COMPLETE (K511S)	
Δ 5	1-696-845-11	CORD, POWER (UK)		* CN1	1-537-473-11	TERMINAL BOARD (LEAD PIN) (K511S)	
Δ 5	1-696-845-11	CORD, POWER (AUS)		Δ F701	1-532-285-00	FUSE, TIME-LAG (1.25A)	
* 6	1-533-213-31	HOLDER, FUSE		Δ F702	1-532-285-00	FUSE, TIME-LAG (1.25A)	
* 7	3-703-244-00	BUSHING (2104), CORD		Q703	8-729-141-83	TRANSISTOR 2SB1094-LK	
* 8	4-949-235-01	HOOK (AEP, Germany)		Q704	8-729-141-89	TRANSISTOR 2SD1585-K	
* 9	3-387-832-01	PANEL, BACK (K511S:UK, AUS)		Q705	8-729-209-15	TRANSISTOR 2SD2012	
* 9	3-387-832-11	PANEL, BACK (K511S:AEP, Germany)		Δ T701	1-423-613-11	TRANSFORMER, POWER	

6-2. FRONT PANEL SECTION

- B : HEADPHONE board
- C : VOLUME board (1/2)
- D : VOLUME board (2/2)

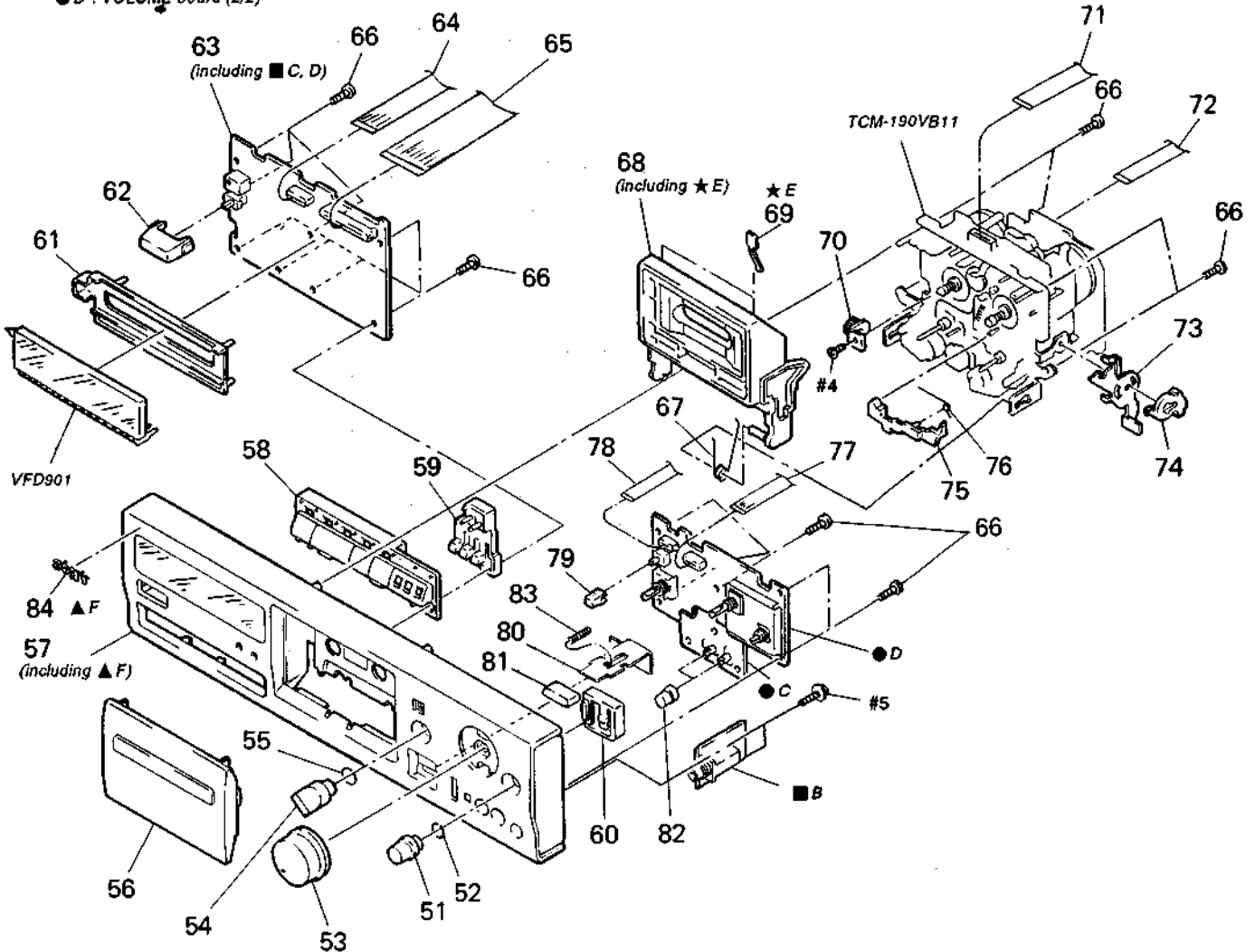

Ref. No.	Part No.	Description	Remark	Ref. No.	Part No.	Description	Remark
51	A-2004-274-A	KNOB (RB) ASSY		67	3-354-960-01	SPRING (LOADING R), TORSION	
52	3-354-981-01	SPRING (SUS), RING		68	X-3365-324-1	HOLDER (R) ASSY, CASSETTE	
53	3-367-438-11	KNOB (REC)		69	3-308-823-11	SPRING	
54	4-908-097-21	KNOB		70	3-354-963-01	DAMPER	
55	3-350-440-01	SPRING		71	1-575-781-11	WIRE, FLAT TYPE (9 CORE)	
56	X-3366-519-1	LID ASSY, CASSETTE (K511S)		72	1-575-780-11	WIRE, FLAT TYPE (7 CORE)	
56	X-3366-521-1	LID ASSY, CASSETTE (K411)		* 73	3-354-954-01	LEVER (LOCK LEVER R)	
57	X-3366-520-1	PANEL ASSY, FRONT (K511S)		74	3-354-957-01	JOINT (LOCK LEVER)	
57	X-3366-522-1	PANEL ASSY, FRONT (K411)		75	3-354-956-01	LEVER (EJ SAFTY LEVER R)	
58	3-386-247-01	BUTTON (FW)		76	3-354-962-01	SPRING (EJ SAFTY SPRING R)	
59	3-386-248-01	BUTTON (RE)		77	1-575-778-11	WIRE, FLAT TYPE (5 CORE)	
60	3-387-834-01	BUTTON (MBC)		78	1-751-098-11	WIRE (FLAT TYPE) (5 CORE)	
* 61	3-386-245-01	HOLDER (FL)		79	3-380-952-01	BUTTON	
62	3-354-932-01	BUTTON (POWER)		80	3-387-833-01	SLIDER (EJECT)	
* 63	A-2007-007-A	PANEL BOARD, COMPLETE (K411)		81	3-387-830-01	BUTTON (EJECT)	
* 63	A-2007-010-A	PANEL BOARD, COMPLETE (K511S)		82	3-367-431-01	KNOB (BAL)	
64	1-751-097-11	WIRE (FLAT TYPE) (11 CORE)		83	3-359-906-01	SPRING, COMPRESSION	
65	1-751-096-11	WIRE (FLAT TYPE) (31 CORE)		84	4-925-334-11	EMBLEM (5-A), SONY	
66	4-951-620-01	SCREW (2.6X8), +BVTP		VFD901	1-517-163-11	INDICATOR TUBE, FLUORESCENT	

6-3. MECHANISM SECTION 1
(TCM-190VB11)

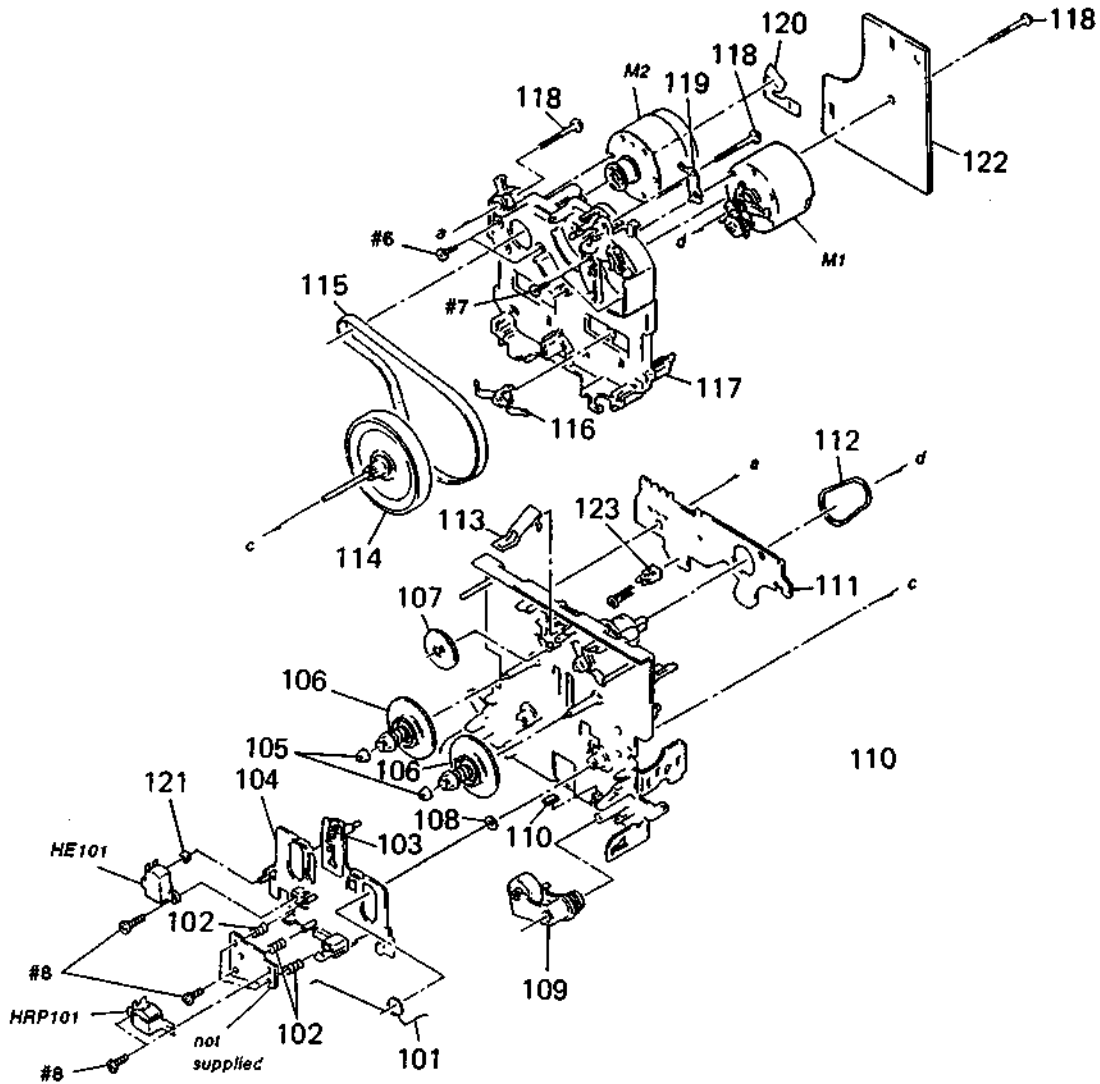

Ref. No.	Part No.	Description	Remark	Ref. No.	Part No.	Description	Remark
101	3-359-455-01	SPRING, TORSION		115	3-359-467-01	BELT (1 WAY FLAT BELT)	
102	3-356-659-01	SPRING (RPH), COMPRESSION		116	3-575-321-00	RETAINER, THRUST, CAPSTAN	
103	3-363-868-01	SPRING (HEAD CHASSIS), TENSION		* 117	3-359-436-01	BASE (THRUST RETAINER), FITTING	
* 104	X-3365-304-1	SLIDER (HEAD PC BOARD) ASSY		118	3-359-414-01	SCREW (+PTPWH 2X23)	
105	3-362-308-01	CAP (REEL)		119	3-359-450-01	PLATE, GROUND	
106	X-3362-078-1	TABLE ASSY (B), REEL		120	1-638-983-11	PC BOARD, MOTOR FLEXIBLE	
107	3-359-424-01	GEAR (REV GEAR)		121	3-701-437-11	WASHER	
108	3-356-713-01	WASHER		* 122	1-634-840-21	AUDIO BOARD	
109	X-3359-408-1	LEVER (PINCH LEVER FWD) ASSY		123	3-343-419-01	HOLDER (S SENSER A)	
110	3-359-469-01	SPACER		HE101	1-543-673-11	HEAD, MAGNETIC (ERASE)	
* 111	1-634-841-14	SW-A BOARD		HRP101	1-543-733-11	HEAD, MAGNETIC (RECORD/PLAYBACK)	
112	3-359-466-01	BELT (FR), SQUARE		M1	X-3363-501-1	MOTOR ASSY, REEL	
113	3-359-430-01	SPRING (CASSETTE RETAINER), LEAF		M2	X-3365-377-1	MOTOR ASSY, CAPSTAN	
114	X-3359-406-1	FLYWHEEL (FWD) ASSY					

**6-4. MECHANISM SECTION 2
(TCM-190VB11)**

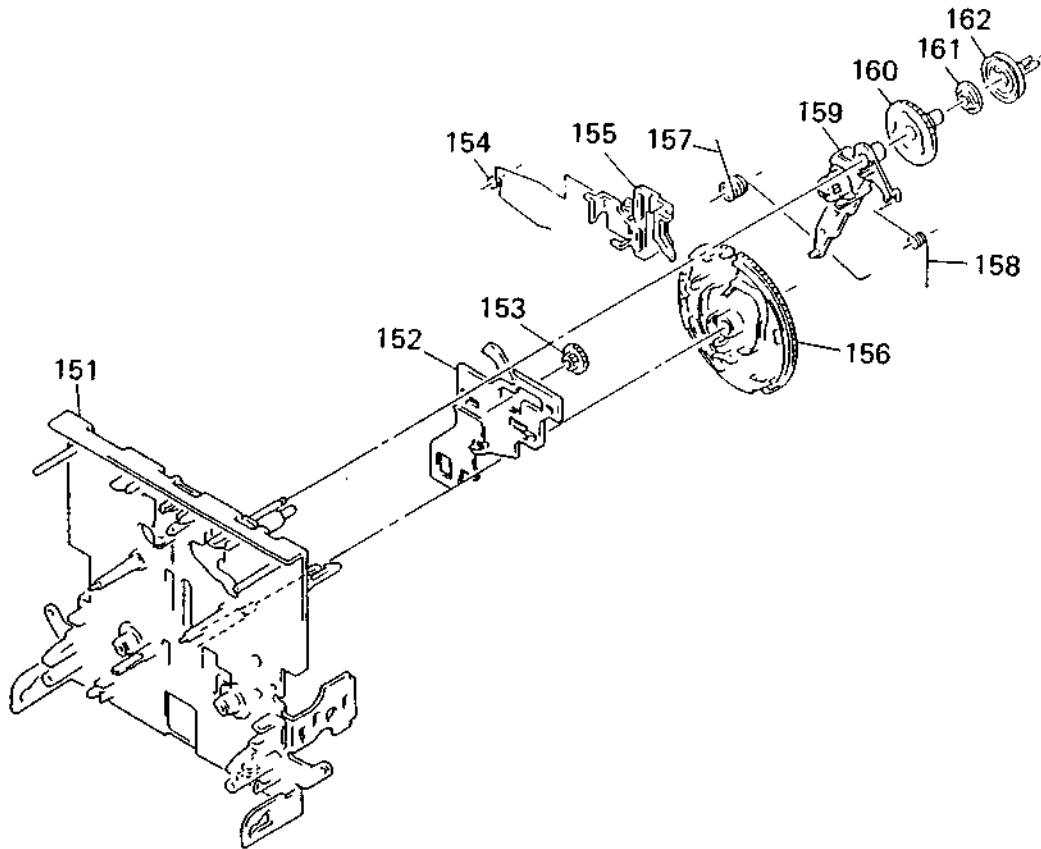

<u>Ref. No.</u>	<u>Part No.</u>	<u>Description</u>	<u>Remark</u>	<u>Ref. No.</u>	<u>Part No.</u>	<u>Description</u>	<u>Remark</u>
151	X-3365-378-1	CHASSIS (ONE) ASSY. MECHANICAL		157	3-359-456-01	SPRING (TRIGGER SPRING), TORSION	
* 152	3-359-415-01	SLIDER (TRIGGER SLIDER)		158	3-359-453-01	SPRING (FR ARM), TORSION	
153	3-359-448-01	GEAR (TRIGGER)		159	X-3359-405-1	LEVER (FR ARM) ASSY	
154	3-359-454-01	SPRING, TORSION		160	3-359-419-01	GEAR (FR GEAR)	
155	3-359-429-01	SLIDER (BRAKE PLATE)		161	3-359-421-01	CLUTCH (REEL DISK)	
156	3-359-420-01	GEAR (CAM GEAR)		162	3-359-418-01	PULLEY (FR PULLEY)	

SECTION 7 ELECTRICAL PARTS LIST

AUDIO DOLBY (S)

NOTE :

- Due to standardization, replacements in the parts list may be different from the parts specified in the diagrams or the components used on the set.
- -XX, -X mean standardized parts, so they may have some difference from the original one.
- RESISTORS
All resistors are in ohms
METAL : Metal-film resistor
METAL OXIDE : Metal oxide-film resistor
F : nonflammable

- Items marked " * " are not stocked since they are seldom required for routine service. Some delay should be anticipated when ordering these items.
- SEMICONDUCTORS
In each case, u : μ , for example :
uA..... : μ A....., uPA..... : μ PA.....
uPB..... : μ PB....., uPC..... : μ PC.....
uPD..... : μ PD.....
- CAPACITORS
uF : μ F
- COILS
uH : μ H

The components identified by mark Δ or dotted line with mark Δ are critical for safety. Replace only with part number specified.

When indicating parts by reference number, please include the board.

● AUS : Australian

Ref. No.	Part No.	Description	Remark
*	1-634-840-21	AUDIO BOARD *****	
		< CAPACITOR >	
C71	1-124-903-11	ELECT	1uF 20% 50V
C72	1-124-903-11	ELECT	1uF 20% 50V
		< CONNECTOR >	
* CNP72	1-580-411-11	SOCKET, CONNECTOR 4P	
* CNP73	1-568-826-11	SOCKET, CONNECTOR 7P	
		< RESISTOR >	
R71	1-249-430-11	CARBON	12K 5% 1/4W
		< VARIABLE RESISTOR >	
RV71	1-238-599-11	RES, ADJ, CARBON 4.7K (TAPE SPEED)	

*	A-2006-954-A	DOLBY (S) BOARD, COMPLETE (K511S) *****	
		< CAPACITOR >	
C1	1-164-222-11	CERAMIC CHIP	0.22uF 25V (K511S)
C2	1-135-177-21	TANTALUM CHIP	1uF 20% 20V (K511S)
C3	1-104-558-91	FILM CHIP	0.039uF 5% 16V (K511S)
C4	1-163-007-11	CERAMIC CHIP	680PF 10% 50V (K511S)
C5	1-163-009-11	CERAMIC CHIP	0.001uF 10% 50V (K511S)
C6	1-164-717-11	CERAMIC CHIP	0.0082uF 5% 50V (K511S)
C7	1-164-222-11	CERAMIC CHIP	0.22uF 25V (K511S)

Ref. No.	Part No.	Description	Remark
C8	1-104-562-11	FILM CHIP	0.082uF 5% 16V (K511S)
C9	1-104-553-11	FILM CHIP	0.015uF 5% 16V (K511S)
C10	1-165-319-11	CERAMIC CHIP	0.1uF 50V (K511S)
C11	1-135-145-11	TANTALUM CHIP	0.47uF 10% 35V (K511S)
C12	1-164-222-11	CERAMIC CHIP	0.22uF 25V (K511S)
C13	1-165-319-11	CERAMIC CHIP	0.1uF 50V (K511S)
C14	1-162-568-11	CERAMIC CHIP	0.33uF 10% 16V (K511S)
C15	1-104-562-11	FILM CHIP	0.082uF 5% 16V (K511S)
C16	1-135-145-11	TANTALUM CHIP	0.47uF 10% 35V (K511S)
C17	1-165-319-11	CERAMIC CHIP	0.1uF 50V (K511S)
C18	1-164-222-11	CERAMIC CHIP	0.22uF 25V (K511S)
C19	1-163-035-00	CERAMIC CHIP	0.047uF 50V (K511S)
C20	1-104-553-11	FILM CHIP	0.015uF 5% 16V (K511S)
C21	1-164-717-11	CERAMIC CHIP	0.0082uF 5% 50V (K511S)
C22	1-163-009-11	CERAMIC CHIP	0.001uF 10% 50V (K511S)
C23	1-164-161-11	CERAMIC CHIP	0.0022uF 10% 100V (K511S)
C24	1-163-005-11	CERAMIC CHIP	470PF 10% 50V (K511S)
C25	1-163-012-00	CERAMIC CHIP	0.0018uF 10% 50V (K511S)

DOLBY (S)

Ref. No.	Part No.	Description	Remark			Ref. No.	Part No.	Description	Remark		
C26	1-104-558-91	FILM CHIP	0.039uF	5%	16V (K511S)	R6	1-216-656-11	METAL CHIP	1.6K	0.5%	1/10W (K511S)
C27	1-163-012-00	CERAMIC CHIP	0.0018uF	10%	50V (K511S)	R7	1-216-657-11	METAL CHIP	1.8K	0.5%	1/10W (K511S)
C28	1-163-012-00	CERAMIC CHIP	0.0018uF	10%	50V (K511S)	R8	1-216-065-00	METAL CHIP	4.7K	5%	1/10W (K511S)
C29	1-104-563-11	FILM CHIP	0.1uF	5%	16V (K511S)	R9	1-216-058-00	METAL GLAZE	2.4K	5%	1/10W (K511S)
C30	1-135-145-11	TANTALUM CHIP	0.47uF	10%	35V (K511S)	R10	1-216-654-11	METAL CHIP	1.3K	0.5%	1/10W (K511S)
C31	1-104-555-11	FILM CHIP	0.022uF	5%	16V (K511S)	R11	1-216-013-00	METAL CHIP	33	5%	1/10W (K511S)
C32	1-104-563-11	FILM CHIP	0.1uF	5%	16V (K511S)	R12	1-216-017-00	METAL CHIP	47	5%	1/10W (K511S)
C33	1-163-024-00	CERAMIC CHIP	0.018uF	10%	50V (K511S)	R13	1-216-051-00	METAL CHIP	1.2K	5%	1/10W (K511S)
C34	1-104-563-11	FILM CHIP	0.1uF	5%	16V (K511S)	R14	1-216-065-00	METAL CHIP	4.7K	5%	1/10W (K511S)
C35	1-163-012-00	CERAMIC CHIP	0.0018uF	10%	50V (K511S)	R15	1-216-058-00	METAL GLAZE	2.4K	5%	1/10W (K511S)
C36	1-165-319-11	CERAMIC CHIP	0.1uF		50V (K511S)	R16	1-216-013-00	METAL CHIP	33	5%	1/10W (K511S)
C37	1-164-222-11	CERAMIC CHIP	0.22uF		25V (K511S)	R17	1-216-017-00	METAL CHIP	47	5%	1/10W (K511S)
C38	1-163-024-00	CERAMIC CHIP	0.018uF	10%	50V (K511S)	R18	1-216-055-00	METAL CHIP	1.8K	5%	1/10W (K511S)
C39	1-104-555-11	FILM CHIP	0.022uF	5%	16V (K511S)	R19	1-216-656-11	METAL CHIP	1.6K	0.5%	1/10W (K511S)
C40	1-104-563-11	FILM CHIP	0.1uF	5%	16V (K511S)	R20	1-216-668-11	METAL CHIP	5.1K	0.5%	1/10W (K511S)
< CONNECTOR >						R21	1-218-774-11	METAL CHIP	820K	0.50%	1/10W (K511S)
* CN1	1-537-473-11	TERMINAL (LEAD PIN)				R22	1-216-655-11	METAL CHIP	1.5K	0.5%	1/10W (K511S)
< IC >						R23	1-216-678-11	METAL CHIP	13K	0.5%	1/10W (K511S)
IC1	8-752-056-51	IC	CXA1417Q-T6 (K511S)			R24	1-216-673-11	METAL CHIP	8.2K	0.5%	1/10W (K511S)
IC2	8-759-711-85	IC	NJM4580E-D (K511S)			R25	1-216-675-11	METAL CHIP	10K	0.5%	1/10W (K511S)
< RESISTOR >						R26	1-216-676-11	METAL CHIP	11K	0.5%	1/10W (K511S)
R1	1-216-013-00	METAL CHIP	33	5%	1/10W (K511S)	R27	1-216-668-11	METAL CHIP	5.1K	0.5%	1/10W (K511S)
R2	1-216-675-11	METAL CHIP	10K	0.5%	1/10W (K511S)	R28	1-216-697-11	METAL CHIP	82K	0.5%	1/10W (K511S)
R3	1-216-681-11	METAL CHIP	18K	0.5%	1/10W (K511S)	R29	1-216-668-11	METAL CHIP	5.1K	0.5%	1/10W (K511S)
R4	1-218-774-11	METAL CHIP	820K	0.50%	1/10W (K511S)						
R5	1-216-668-11	METAL CHIP	5.1K	0.5%	1/10W (K511S)						

DOLBY (S) MAIN

Ref. No.	Part No.	Description	Remark
R30	1-216-660-11	METAL CHIP	2.4K 0.5% 1/10W (K511S)
R31	1-216-680-11	METAL CHIP	16K 0.5% 1/10W (K511S)
R32	1-216-685-11	METAL CHIP	27K 0.5% 1/10W (K511S)
R33	1-216-080-00	METAL CHIP	20K 5% 1/10W (K511S)
R34	1-216-684-11	METAL CHIP	24K 0.5% 1/10W (K511S)
R35	1-216-084-00	METAL CHIP	30K 5% 1/10W (K511S)
R36	1-216-084-00	METAL CHIP	30K 5% 1/10W (K511S)
R37	1-216-074-00	METAL CHIP	11K 5% 1/10W (K511S)
R38	1-216-086-00	METAL GLAZE	36K 5% 1/10W (K511S)
R39	1-216-066-00	METAL CHIP	5.1K 5% 1/10W (K511S)
R40	1-216-084-00	METAL CHIP	30K 5% 1/10W (K511S)
R41	1-216-078-00	METAL GLAZE	16K 5% 1/10W (K511S)
R42	1-216-071-00	METAL CHIP	8.2K 5% 1/10W (K511S)
R43	1-216-081-00	METAL CHIP	22K 5% 1/10W (K511S)
R44	1-216-689-11	METAL CHIP	39K 0.5% 1/10W (K511S)
R45	1-216-689-11	METAL CHIP	39K 0.5% 1/10W (K511S)
R53	1-216-058-00	METAL GLAZE	2.4K 5% 1/10W (K511S)
R54	1-216-675-11	METAL CHIP	10K 0.5% 1/10W (K511S)
R55	1-216-666-11	METAL CHIP	4.3K 0.5% 1/10W (K511S)

*	A-2007-008-A	MAIN BOARD, COMPLETE (K411)	*****
*	A-2007-009-A	MAIN BOARD, COMPLETE (K511S)	*****
*	1-533-213-31	HOLDER, FUSE	
*	1-690-880-31	LEAD (WITH CONNECTOR) (K511S)	
< CAPACITOR >			
C101	1-124-927-11	ELECT	4.7uF 20% 100V
C102	1-161-375-00	CERAMIC	0.0022uF 20% 50V

Ref. No.	Part No.	Description	Remark
C104	1-130-475-00	MYLAR	0.0022uF 5% 50V
C105	1-130-475-00	MYLAR	0.0022uF 5% 50V
C106	1-136-174-00	FILM	0.56uF 5% 50V
C107	1-136-171-00	FILM	0.33uF 5% 50V
C108	1-124-907-11	ELECT	10uF 20% 50V
C109	1-124-907-11	ELECT	10uF 20% 50V
C110	1-136-175-00	FILM	0.68uF 5% 50V
C111	1-124-907-11	ELECT	10uF 20% 50V
C112	1-124-907-11	ELECT	10uF 20% 50V
C113	1-110-338-51	MYLAR	180PF 5% 50V
C114	1-136-935-11	FILM	22PF 5% 630V
C115	1-110-340-11	MYLAR	270PF 5% 50V
C116	1-130-474-00	MYLAR	0.0018uF 5% 50V
C117	1-136-157-00	FILM	0.022uF 5% 50V
C118	1-126-320-11	ELECT, NONPOLAR	10uF 20% 16V
C119	1-102-518-11	CERAMIC	33PF 5% 50V
C120	1-130-488-00	MYLAR	0.027uF 5% 50V
C121	1-124-925-11	ELECT	2.2uF 20% 100V
C122	1-136-153-00	FILM	0.01uF 5% 50V
C123	1-136-157-00	FILM	0.022uF 5% 50V
C124	1-136-161-00	FILM	0.047uF 5% 50V
C125	1-136-803-11	FILM	560PF 5% 630V
C126	1-130-468-00	MYLAR	560PF 5% 50V
C127	1-136-433-11	FILM	100PF 5% 630V
C128	1-130-474-00	MYLAR	0.0018uF 5% 50V
C130	1-130-475-00	MYLAR	0.0022uF 5% 50V
C131	1-130-475-00	MYLAR	0.0022uF 5% 50V
C132	1-130-475-00	MYLAR	0.0022uF 5% 50V
C133	1-136-174-00	FILM	0.56uF 5% 50V
C134	1-136-171-00	FILM	0.33uF 5% 50V
C135	1-124-907-11	ELECT	10uF 20% 50V
C136	1-124-907-11	ELECT	10uF 20% 50V (K511S)
C137	1-124-916-11	ELECT	22uF 20% 63V (K511S)
C138	1-124-907-11	ELECT	10uF 20% 50V (K511S)
C139	1-124-907-11	ELECT	10uF 20% 50V (K511S)
C140	1-124-916-11	ELECT	22uF 20% 63V (K511S)
C141	1-124-907-11	ELECT	10uF 20% 50V (K511S)
C142	1-124-907-11	ELECT	10uF 20% 50V
C143	1-124-907-11	ELECT	10uF 20% 50V
C201	1-124-927-11	ELECT	4.7uF 20% 100V
C202	1-161-375-00	CERAMIC	0.0022uF 20% 50V
C204	1-130-475-00	MYLAR	0.0022uF 5% 50V
C205	1-130-475-00	MYLAR	0.0022uF 5% 50V



Ref. No.	Part No.	Description	Remark	Ref. No.	Part No.	Description	Remark
C206	1-136-174-00	FILM	0.56uF 5% 50V	C307	1-124-443-00	ELECT	100uF 20% 10V
C207	1-136-171-00	FILM	0.33uF 5% 50V	C308	1-124-443-00	ELECT	100uF 20% 10V
C208	1-124-907-11	ELECT	10uF 20% 50V	C309	1-162-217-31	CERAMIC	56PF 5% 50V
C209	1-124-907-11	ELECT	10uF 20% 50V	C310	1-161-494-00	CERAMIC	0.022uF 25V
C210	1-136-175-00	FILM	0.68uF 5% 50V	C311	1-124-925-11	ELECT	2.2uF 20% 100V
C211	1-124-907-11	ELECT	10uF 20% 50V	C312	1-162-217-31	CERAMIC	56PF 5% 50V
C212	1-124-907-11	ELECT	10uF 20% 50V	C313	1-124-925-11	ELECT	2.2uF 20% 100V
C213	1-110-338-51	MYLAR	180PF 5% 50V	C314	1-124-907-11	ELECT	10uF 20% 50V
C214	1-136-935-11	FILM	22PF 5% 630V				(K511S)
C215	1-110-340-11	MYLAR	270PF 5% 50V	C315	1-124-907-11	ELECT	10uF 20% 50V
							(K511S)
C216	1-130-474-00	MYLAR	0.0018uF 5% 50V	C316	1-124-902-00	ELECT	0.47uF 20% 50V
C217	1-136-157-00	FILM	0.022uF 5% 50V	C317	1-162-306-11	CERAMIC	0.01uF 20% 16V
C218	1-126-320-11	ELECT, NONPOLAR	10uF 20% 16V	C318	1-124-907-11	ELECT	10uF 20% 50V
C219	1-102-518-11	CERAMIC	33PF 5% 50V	C319	1-124-907-11	ELECT	10uF 20% 50V
C220	1-130-488-00	MYLAR	0.027uF 5% 50V	C320	1-124-477-11	ELECT	47uF 20% 25V
C221	1-124-925-11	ELECT	2.2uF 20% 100V	C321	1-124-477-11	ELECT	47uF 20% 25V
C222	1-136-153-00	FILM	0.01uF 5% 50V	C322	1-136-253-11	FILM	0.0018uF 5% 100V
C223	1-136-157-00	FILM	0.022uF 5% 50V	C323	1-136-253-11	FILM	0.0018uF 5% 100V
C224	1-136-161-00	FILM	0.047uF 5% 50V	C324	1-136-233-11	FILM	0.0047uF 5% 100V
C225	1-136-803-11	FILM	560PF 5% 630V	C325	1-124-916-11	ELECT	22uF 20% 63V
C226	1-130-468-00	MYLAR	560PF 5% 50V	C326	1-136-558-11	FILM	0.0039uF 5% 630V
C227	1-136-433-11	FILM	100PF 5% 630V	C327	1-107-045-00	MICA	3.9PF 500V
C228	1-130-474-00	MYLAR	0.0018uF 5% 50V	C329	1-161-494-00	CERAMIC	0.022uF 25V
C230	1-130-475-00	MYLAR	0.0022uF 5% 50V	C330	1-124-907-11	ELECT	10uF 20% 50V
C231	1-130-475-00	MYLAR	0.0022uF 5% 50V	C331	1-124-907-11	ELECT	10uF 20% 50V
C232	1-130-475-00	MYLAR	0.0022uF 5% 50V	C364	1-124-907-11	ELECT	10uF 20% 50V
C233	1-136-174-00	FILM	0.56uF 5% 50V	C365	1-124-907-11	ELECT	10uF 20% 50V
C234	1-136-171-00	FILM	0.33uF 5% 50V	C701	1-126-936-11	ELECT	3300uF 20% 16V
C235	1-124-907-11	ELECT	10uF 20% 50V	C702	1-126-936-11	ELECT	3300uF 20% 16V
C236	1-124-907-11	ELECT	10uF 20% 50V	C703	1-126-176-11	ELECT	220uF 20% 10V
			(K511S)	C704	1-126-926-11	ELECT	1000uF 20% 10V
C237	1-124-916-11	ELECT	22uF 20% 63V	C705	1-126-926-11	ELECT	1000uF 20% 10V
			(K511S)	C706	1-124-120-11	ELECT	220uF 20% 25V
C238	1-124-907-11	ELECT	10uF 20% 50V	C707	1-124-927-11	ELECT	4.7uF 20% 100V
			(K511S)	C708	1-162-294-31	CERAMIC	0.001uF 20% 50V
C239	1-124-907-11	ELECT	10uF 20% 50V	C709	1-162-294-31	CERAMIC	0.001uF 20% 50V
			(K511S)	C712	1-124-903-11	ELECT	1uF 20% 50V
C240	1-124-916-11	ELECT	22uF 20% 63V	C713	1-126-926-11	ELECT	1000uF 20% 10V
			(K511S)	C714	1-124-122-11	ELECT	100uF 20% 50V
C241	1-124-907-11	ELECT	10uF 20% 50V	C715	1-124-910-11	ELECT	47uF 20% 50V
			(K511S)	C716	1-164-159-11	CERAMIC	0.1uF 50V
C242	1-124-907-11	ELECT	10uF 20% 50V	C801	1-124-443-00	ELECT	100uF 20% 10V
C243	1-124-907-11	ELECT	10uF 20% 50V	C802	1-126-176-11	ELECT	220uF 20% 10V
C301	1-124-907-11	ELECT	10uF 20% 50V	C805	1-164-159-11	CERAMIC	0.1uF 50V
C302	1-124-907-11	ELECT	10uF 20% 50V	C808	1-123-382-00	ELECT	3.3uF 20% 100V
C303	1-130-478-00	MYLAR	0.0039uF 5% 50V	C809	1-164-159-11	CERAMIC	0.1uF 50V
C304	1-124-907-11	ELECT	10uF 20% 50V	C850	1-164-159-11	CERAMIC	0.1uF 50V
C305	1-136-164-00	FILM	0.082uF 5% 50V				(K511S)
C306	1-124-903-11	ELECT	1uF 20% 50V				

MAIN

Ref. No.	Part No.	Description	Remark	Ref. No.	Part No.	Description	Remark
C850	1-161-357-00	CERAMIC	0.0022uF 20% 50V (K411)	D715	8-719-987-63	DIODE 1N4148M	
< CONNECTOR >				D718	8-719-200-77	DIODE 10E2N	
* CNP301	1-564-337-00	PIN, CONNECTOR	3P	D801	8-719-987-63	DIODE 1N4148M	
* CNP302	1-560-062-00	PIN, CONNECTOR	4P	D802	8-719-933-33	DIODE HZS6A1L	
* CNP303	1-560-060-00	PIN, CONNECTOR	2P	D803	8-719-933-33	DIODE HZS6A1L	
* CNP304	1-560-062-00	PIN, CONNECTOR	4P	D806	8-719-987-63	DIODE 1N4148M	
* CNP305	1-691-462-11	PIN, CONNECTOR (PC BOARD)	6P	D814	8-719-987-63	DIODE 1N4148M	
* CNP306	1-568-824-11	SOCKET, CONNECTOR	5P	D815	8-719-987-63	DIODE 1N4148M	
* CNP307	1-568-824-11	SOCKET, CONNECTOR	5P	< FUSE >			
* CNP701	1-564-510-11	PLUG, CONNECTOR	7P	△F701	1-532-285-00	FUSE, TIME-LAG (1.25A)	
* CNP705	1-580-230-31	PIN, CONNECTOR (PC BOARD)	2P	△F702	1-532-285-00	FUSE, TIME-LAG (1.25A)	
* CNP801	1-568-828-11	SOCKET, CONNECTOR	9P	< IC >			
* CNP802	1-568-826-11	SOCKET, CONNECTOR	7P	IC301	8-759-111-44	IC uPC4570C-1	
* CNP803	1-568-845-11	SOCKET, CONNECTOR	31P	IC302	8-752-059-55	IC CXA1331S	
* CNP804	1-568-830-11	SOCKET, CONNECTOR	11P	IC303	8-752-060-64	IC CXA1198AP	
< DIODE >				IC304	8-759-106-56	IC uPC1297CA	
D101	8-719-987-63	DIODE	1N4148M	IC305	8-759-145-58	IC uPC4558C	
D102	8-719-987-63	DIODE	1N4148M	IC306	8-759-145-58	IC uPC4558C	
D201	8-719-987-63	DIODE	1N4148M	IC307	8-752-059-55	IC CXA1331S	
D202	8-719-987-63	DIODE	1N4148M	IC308	8-759-634-50	IC M5218AL	
D301	8-719-987-63	DIODE	1N4148M (K511S)	IC309	8-759-634-50	IC M5218AL	
D302	8-719-987-63	DIODE	1N4148M (K511S)	IC310	8-759-000-49	IC MC14066BCP	
D303	8-719-987-63	DIODE	1N4148M (K511S)	IC311	8-759-000-49	IC MC14066BCP (K511S)	
D304	8-719-987-63	DIODE	1N4148M (K511S)	IC312	8-759-000-49	IC MC14066BCP (K511S)	
D305	8-719-987-63	DIODE	1N4148M	IC701	8-759-634-51	IC M5218AP	
D306	8-719-987-63	DIODE	1N4148M	IC801	8-752-841-98	IC CXP82316-018Q	
D307	8-719-987-63	DIODE	1N4148M	IC802	8-759-803-42	IC LA6500-FA	
D308	8-719-987-63	DIODE	1N4148M	IC803	8-759-165-82	IC PST600E-T	
D310	8-719-987-63	DIODE	1N4148M	< JACK >			
D311	8-719-987-63	DIODE	1N4148M	J301	1-565-258-11	JACK, PIN 4P (HEADPHONES)	
D312	8-719-987-63	DIODE	1N4148M	J302	1-568-519-41	JACK, LARGE TYPE (LINE IN/OUT)	
D313	8-719-987-63	DIODE	1N4148M	< COIL >			
D314	8-719-987-63	DIODE	1N4148M	L101	1-410-780-11	INDUCTOR 27mH	
D701	8-719-200-77	DIODE	10E2N	L121	1-410-778-11	INDUCTOR 18mH	
D702	8-719-200-77	DIODE	10E2N	L201	1-410-780-11	INDUCTOR 27mH	
D703	8-719-200-77	DIODE	10E2N	L221	1-410-778-11	INDUCTOR 18mH	
D704	8-719-200-77	DIODE	10E2N	< FILTER >			
D705	8-719-933-33	DIODE	HZS6A1L	LPF101	1-231-388-00	FILTER, LOW PASS	
D706	8-719-933-33	DIODE	HZS6A1L	LPF201	1-231-388-00	FILTER, LOW PASS	
D707	8-719-200-77	DIODE	10E2N	< TRANSISTOR >			
D708	8-719-200-77	DIODE	10E2N	Q101	8-729-900-74	TRANSISTOR DTC143TS	
D709	8-719-987-63	DIODE	1N4148M	Q102	8-729-900-80	TRANSISTOR DTC114BS	
D711	8-719-000-78	DIODE	UZL-7L2				
D712	8-719-200-77	DIODE	10E2N				
D713	8-719-987-63	DIODE	1N4148M				
D714	8-719-000-93	DIODE	UZL-7H1				

The components identified by mark \triangle or dotted line with mark \triangle are critical for safety. Replace only with part number specified.

Ref. No.	Part No.	Description	Remark	Ref. No.	Part No.	Description	Remark
Q103	8-729-922-37	TRANSISTOR	2SD2144S-UVW	R103	1-249-423-11	CARBON	3. 3K 5% 1/4W
Q104	8-729-620-05	TRANSISTOR	2SC2603-EF	R104	1-249-428-11	CARBON	8. 2K 5% 1/4W
Q105	8-729-900-80	TRANSISTOR	DTC114ES	R105	1-247-864-11	CARBON	24K 5% 1/4W
Q201	8-729-900-74	TRANSISTOR	DTC143TS	R106	1-249-414-11	CARBON	560 5% 1/4W
Q202	8-729-900-80	TRANSISTOR	DTC114ES	R107	1-249-421-11	CARBON	2. 2K 5% 1/4W
Q203	8-729-922-37	TRANSISTOR	2SD2144S-UVW	R108	1-247-860-11	CARBON	16K 5% 1/4W
Q204	8-729-620-05	TRANSISTOR	2SC2603-EF	R109	1-249-421-11	CARBON	2. 2K 5% 1/4W
Q205	8-729-900-80	TRANSISTOR	DTC114ES	R110	1-249-417-11	CARBON	1K 5% 1/4W
Q301	8-729-119-76	TRANSISTOR	2SA1175-HFE	R111	1-249-437-11	CARBON	47K 5% 1/4W
Q302	8-729-900-80	TRANSISTOR	DTC114ES	R112	1-249-423-11	CARBON	3. 3K 5% 1/4W
Q303	8-729-900-80	TRANSISTOR	DTC114ES	R113	1-249-424-11	CARBON	3. 9K 5% 1/4W
Q304	8-729-900-80	TRANSISTOR	DTC114ES	R114	1-249-429-11	CARBON	10K 5% 1/4W
Q305	8-729-119-76	TRANSISTOR	2SA1175-HFE	R115	1-249-421-11	CARBON	2. 2K 5% 1/4W
Q306	8-729-900-89	TRANSISTOR	DTC144ES	R116	1-249-425-11	CARBON	4. 7K 5% 1/4W
Q307	8-729-900-80	TRANSISTOR	DTC114ES	R117	1-249-441-11	CARBON	100K 5% 1/4W
Q308	8-729-900-80	TRANSISTOR	DTC114ES	R118	1-249-403-11	CARBON	68 5% 1/4W
Q309	8-729-900-80	TRANSISTOR	DTC114ES	R119	1-247-882-11	CARBON	130K 5% 1/4W
Q310	8-729-194-57	TRANSISTOR	2SC945-P	R120	1-249-426-11	CARBON	5. 6K 5% 1/4W
Q311	8-729-194-57	TRANSISTOR	2SC945-P	R121	1-249-421-11	CARBON	2. 2K 5% 1/4W
Q312	8-729-922-37	TRANSISTOR	2SD2144S-UVW	R122	1-249-420-11	CARBON	1. 8K 5% 1/4W
Q313	8-729-620-05	TRANSISTOR	2SC2603-EF	R123	1-247-838-00	CARBON	2K 5% 1/4W
Q314	8-729-620-05	TRANSISTOR	2SC2603-EF	R124	1-249-437-11	CARBON	47K 5% 1/4W
Q315	8-729-900-80	TRANSISTOR	DTC114ES	R125	1-249-421-11	CARBON	2. 2K 5% 1/4W
Q701	8-729-900-80	TRANSISTOR	DTC114ES	R126	1-249-425-11	CARBON	4. 7K 5% 1/4W
Q702	8-729-900-80	TRANSISTOR	DTC114ES	R127	1-249-435-11	CARBON	33K 5% 1/4W
Q703	8-729-141-83	TRANSISTOR	2SB1094-LK	△R128	1-219-153-11	FUSIBLE	10 5% 1/4W F
Q704	8-729-141-89	TRANSISTOR	2SD1585-K	R129	1-247-883-00	CARBON	150K 5% 1/4W
Q705	8-729-209-15	TRANSISTOR	2SD2012	R130	1-249-434-11	CARBON	27K 5% 1/4W
Q706	8-729-620-05	TRANSISTOR	2SC2603-EF	R131	1-247-874-11	CARBON	62K 5% 1/4W
Q707	8-729-900-80	TRANSISTOR	DTC114ES	R132	1-249-425-11	CARBON	4. 7K 5% 1/4W
Q708	8-729-119-76	TRANSISTOR	2SA1175-HFE	R133	1-249-410-11	CARBON	270 5% 1/4W
Q709	8-729-140-04	TRANSISTOR	2SB1116A-L	R134	1-247-864-11	CARBON	24K 5% 1/4W
Q801	8-729-900-89	TRANSISTOR	DTC144ES	R135	1-249-414-11	CARBON	560 5% 1/4W
Q802	8-729-801-84	TRANSISTOR	2SB1013-4	R136	1-249-429-11	CARBON	10K 5% 1/4W
Q803	8-729-900-61	TRANSISTOR	DTA114ES	R137	1-215-445-00	METAL	10K 1% 1/6W (K511S)
Q804	8-729-900-61	TRANSISTOR	DTA114ES	R138	1-215-445-00	METAL	10K 1% 1/6W (K511S)
Q805	8-729-900-61	TRANSISTOR	DTA114ES	R139	1-215-440-00	METAL	6. 2K 1% 1/6W (K511S)
Q806	8-729-900-89	TRANSISTOR	DTC144ES	R140	1-215-449-00	METAL	15K 1% 1/6W (K511S)
Q807	8-729-115-28	TRANSISTOR	BN1L3Z-K	R141	1-249-419-11	CARBON	1. 5K 5% 1/4W
Q808	8-729-900-61	TRANSISTOR	DTA114ES	R142	1-249-421-11	CARBON	2. 2K 5% 1/4W
Q809	8-729-900-61	TRANSISTOR	DTA114ES	R143	1-247-844-11	CARBON	3. 6K 5% 1/4W
Q810	8-729-900-80	TRANSISTOR	DTC114ES	R144	1-249-409-11	CARBON	220 5% 1/4W
Q813	8-729-900-61	TRANSISTOR	DTA114ES	R145	1-249-426-11	CARBON	5. 6K 5% 1/4W
Q814	8-729-900-61	TRANSISTOR	DTA114ES	R146	1-249-437-11	CARBON	47K 5% 1/4W (K511S)
Q815	8-729-900-61	TRANSISTOR	DTA114ES				
< RESISTOR >							
R101	1-249-433-11	CARBON	22K 5% 1/4W				
R102	1-249-417-11	CARBON	1K 5% 1/4W				

The components identified by mark  or dotted line with mark  are critical for safety. Replace only with part number specified.

MAIN

Ref. No.	Part No.	Description	Remark	Ref. No.	Part No.	Description	Remark
R147	1-215-449-00	METAL	15K 1% 1/6W (K511S)	R238	1-215-445-00	METAL	10K 1% 1/6W (K511S)
R148	1-215-424-00	METAL	1.3K 1% 1/6W (K511S)	R239	1-215-440-00	METAL	6.2K 1% 1/6W (K511S)
R149	1-215-425-00	METAL	1.5K 1% 1/6W (K511S)	R240	1-215-449-00	METAL	15K 1% 1/6W (K511S)
R150	1-215-447-00	METAL	12K 1% 1/6W (K511S)	R241	1-249-419-11	CARBON	1.5K 5% 1/4W
R151	1-249-437-11	CARBON	47K 5% 1/4W (K511S)	R242	1-249-421-11	CARBON	2.2K 5% 1/4W
R152	1-247-887-00	CARBON	220K 5% 1/4W	R243	1-247-844-11	CARBON	3.6K 5% 1/4W
R201	1-249-433-11	CARBON	22K 5% 1/4W	R244	1-249-409-11	CARBON	220 5% 1/4W
R202	1-249-417-11	CARBON	1K 5% 1/4W	R245	1-249-426-11	CARBON	5.6K 5% 1/4W
R203	1-249-423-11	CARBON	3.3K 5% 1/4W	R246	1-249-437-11	CARBON	47K 5% 1/4W (K511S)
R204	1-249-428-11	CARBON	8.2K 5% 1/4W	R247	1-215-449-00	METAL	15K 1% 1/6W (K511S)
R205	1-247-864-11	CARBON	24K 5% 1/4W	R248	1-215-424-00	METAL	1.3K 1% 1/6W (K511S)
R206	1-249-414-11	CARBON	560 5% 1/4W	R249	1-215-425-00	METAL	1.5K 1% 1/6W (K511S)
R207	1-249-421-11	CARBON	2.2K 5% 1/4W	R250	1-215-447-00	METAL	12K 1% 1/6W (K511S)
R208	1-247-860-11	CARBON	16K 5% 1/4W	R251	1-249-437-11	CARBON	47K 5% 1/4W (K511S)
R209	1-249-421-11	CARBON	2.2K 5% 1/4W	R252	1-247-887-00	CARBON	220K 5% 1/4W
R210	1-249-417-11	CARBON	1K 5% 1/4W	R301	1-249-417-11	CARBON	1K 5% 1/4W
R211	1-249-437-11	CARBON	47K 5% 1/4W	R302	1-247-848-11	CARBON	5.1K 5% 1/4W
R212	1-249-423-11	CARBON	3.3K 5% 1/4W	R303	1-249-421-11	CARBON	2.2K 5% 1/4W
R213	1-249-424-11	CARBON	3.9K 5% 1/4W	R304	1-249-421-11	CARBON	2.2K 5% 1/4W
R214	1-249-429-11	CARBON	10K 5% 1/4W	R305	1-215-455-00	METAL	27K 1% 1/6W
R215	1-249-421-11	CARBON	2.2K 5% 1/4W	R306	1-249-436-11	CARBON	39K 5% 1/4W
R216	1-249-425-11	CARBON	4.7K 5% 1/4W	R307	1-249-433-11	CARBON	22K 5% 1/4W
R217	1-249-441-11	CARBON	100K 5% 1/4W	R308	1-249-441-11	CARBON	100K 5% 1/4W
R218	1-249-403-11	CARBON	68 5% 1/4W	R309	1-247-864-11	CARBON	24K 5% 1/4W
R219	1-247-882-11	CARBON	130K 5% 1/4W	R310	1-249-441-11	CARBON	100K 5% 1/4W
R220	1-249-426-11	CARBON	5.6K 5% 1/4W	R311	1-249-441-11	CARBON	100K 5% 1/4W
R221	1-249-421-11	CARBON	2.2K 5% 1/4W	R312	1-249-433-11	CARBON	22K 5% 1/4W
R222	1-249-420-11	CARBON	1.8K 5% 1/4W	R313	1-247-878-00	CARBON	91K 5% 1/4W
R223	1-247-838-00	CARBON	2K 5% 1/4W	R314	1-249-439-11	CARBON	68K 5% 1/4W
R224	1-249-437-11	CARBON	47K 5% 1/4W	R315	1-247-870-11	CARBON	43K 5% 1/4W
R225	1-249-421-11	CARBON	2.2K 5% 1/4W	R316	1-249-435-11	CARBON	33K 5% 1/4W
R226	1-249-425-11	CARBON	4.7K 5% 1/4W	R317	1-247-876-11	CARBON	75K 5% 1/4W
R227	1-249-435-11	CARBON	33K 5% 1/4W	R318	1-247-887-00	CARBON	220K 5% 1/4W
△R228	1-219-153-11	FUSIBLE	10 5% 1/4W F	R319	1-247-878-00	CARBON	91K 5% 1/4W
R229	1-247-883-00	CARBON	150K 5% 1/4W	R320	1-247-874-11	CARBON	62K 5% 1/4W
R230	1-249-434-11	CARBON	27K 5% 1/4W	R321	1-247-878-00	CARBON	91K 5% 1/4W
R231	1-247-874-11	CARBON	62K 5% 1/4W	R322	1-249-437-11	CARBON	47K 5% 1/4W
R232	1-249-425-11	CARBON	4.7K 5% 1/4W	R323	1-249-439-11	CARBON	68K 5% 1/4W
R233	1-249-410-11	CARBON	270 5% 1/4W	R324	1-247-886-11	CARBON	200K 5% 1/4W
R234	1-247-864-11	CARBON	24K 5% 1/4W	R325	1-247-874-11	CARBON	62K 5% 1/4W
R235	1-249-414-11	CARBON	560 5% 1/4W				
R236	1-249-429-11	CARBON	10K 5% 1/4W				
R237	1-215-445-00	METAL	10K 1% 1/6W (K511S)				

The components identified by mark Δ or dotted line with mark Δ are critical for safety. Replace only with part number specified.

Ref. No.	Part No.	Description		Remark
R326	1-247-874-11	CARBON	62K	5% 1/4W
R327	1-249-435-11	CARBON	33K	5% 1/4W
R328	1-249-438-11	CARBON	56K	5% 1/4W
R329	1-249-440-11	CARBON	82K	5% 1/4W
R330	1-247-836-11	CARBON	1.6K	5% 1/4W
R331	1-249-417-11	CARBON	1K	5% 1/4W
R332	1-249-422-11	CARBON	2.7K	5% 1/4W
R333	1-249-417-11	CARBON	1K	5% 1/4W
R334	1-249-417-11	CARBON	1K	5% 1/4W
R335	1-247-822-11	CARBON	430	5% 1/4W
R336	1-249-417-11	CARBON	1K	5% 1/4W
R337	1-249-437-11	CARBON	47K	5% 1/4W
R338	1-249-421-11	CARBON	2.2K	5% 1/4W
R339	1-249-440-11	CARBON	82K	5% 1/4W
R340	1-249-440-11	CARBON	82K	5% 1/4W
R341	1-249-390-11	CARBON	5.6	5% 1/6W
R342	1-249-390-11	CARBON	5.6	5% 1/6W
R343	1-249-437-11	CARBON	47K	5% 1/4W
R344	1-249-429-11	CARBON	10K	5% 1/4W
R345	1-249-441-11	CARBON	100K	5% 1/4W
R346	1-249-441-11	CARBON	100K	5% 1/4W
R347	1-249-429-11	CARBON	10K	5% 1/4W
R348	1-249-428-11	CARBON	8.2K	5% 1/4W
R349	1-249-441-11	CARBON	100K	5% 1/4W
R350	1-249-441-11	CARBON	100K	5% 1/4W
R351	1-249-423-11	CARBON	3.3K	5% 1/4W
R352	1-249-429-11	CARBON	10K	5% 1/4W
R353	1-249-429-11	CARBON	10K	5% 1/4W
R354	1-249-417-11	CARBON	1K	5% 1/4W
R355	1-249-430-11	CARBON	12K	5% 1/4W
R356	1-249-435-11	CARBON	33K	5% 1/4W
R357	1-247-848-11	CARBON	5.1K	5% 1/4W
R358	1-249-437-11	CARBON	47K	5% 1/4W
R359	1-249-434-11	CARBON	27K	5% 1/4W
R360	1-249-429-11	CARBON	10K	5% 1/4W
R361	1-249-437-11	CARBON	47K	5% 1/4W
R363	1-215-455-00	METAL	27K	1% 1/6W
R364	1-249-437-11	CARBON	47K	5% 1/4W
R365	1-249-431-11	CARBON	15K	5% 1/4W
R366	1-247-862-11	CARBON	20K	5% 1/4W
R367	1-249-429-11	CARBON	10K	5% 1/4W
R368	1-249-425-11	CARBON	4.7K	5% 1/4W
R701	1-249-433-11	CARBON	22K	5% 1/4W
R702	1-249-425-11	CARBON	4.7K	5% 1/4W
R703	1-249-420-11	CARBON	1.8K	5% 1/4W
R704	1-249-421-11	CARBON	2.2K	5% 1/4W
R705	1-249-427-11	CARBON	6.8K	5% 1/4W
R706	1-249-419-11	CARBON	1.5K	5% 1/4W
R707	1-249-429-11	CARBON	10K	5% 1/4W

Ref. No.	Part No.	Description		Remark
R708	1-249-419-11	CARBON	1.5K	5% 1/4W
R709	1-249-425-11	CARBON	4.7K	5% 1/4W
R711	1-249-417-11	CARBON	1K	5% 1/4W
R712	1-249-427-11	CARBON	6.8K	5% 1/4W
R713	1-249-427-11	CARBON	6.8K	5% 1/4W
R714	1-249-419-11	CARBON	1.5K	5% 1/4W
R715	1-249-425-11	CARBON	4.7K	5% 1/4W
R716	1-249-429-11	CARBON	10K	5% 1/4W
R718	1-249-433-11	CARBON	22K	5% 1/4W
R719	1-249-429-11	CARBON	10K	5% 1/4W
R720	1-249-423-11	CARBON	3.3K	5% 1/4W
R721	1-249-437-11	CARBON	47K	5% 1/4W
R801	1-249-435-11	CARBON	33K	5% 1/4W
R803	1-247-862-11	CARBON	20K	5% 1/4W
R802	1-249-429-11	CARBON	10K	5% 1/4W
R804	1-249-429-11	CARBON	10K	5% 1/4W
R805	1-249-417-11	CARBON	1K	5% 1/4W
R806	1-249-417-11	CARBON	1K	5% 1/4W
R807	1-249-430-11	CARBON	12K	5% 1/4W
R808	1-249-433-11	CARBON	22K	5% 1/4W
R809	1-249-433-11	CARBON	22K	5% 1/4W
R810	1-249-435-11	CARBON	33K	5% 1/4W
R811	1-249-425-11	CARBON	4.7K	5% 1/4W
R812	1-249-425-11	CARBON	4.7K	5% 1/4W
R813	1-247-866-11	CARBON	30K	5% 1/4W
R814	1-247-866-11	CARBON	30K	5% 1/4W
R815	1-249-437-11	CARBON	47K	5% 1/4W
R817	1-249-441-11	CARBON	100K	5% 1/4W
R818	1-249-417-11	CARBON	1K	5% 1/4W
R821	1-249-433-11	CARBON	22K	5% 1/4W
R822	1-249-393-11	CARBON	10	5% 1/4W
R823	1-249-437-11	CARBON	47K	5% 1/4W
R824	1-249-437-11	CARBON	47K	5% 1/4W
R825	1-249-429-11	CARBON	10K	5% 1/4W
R826	1-249-429-11	CARBON	10K	5% 1/4W
R827	1-249-405-11	CARBON	100	5% 1/4W
R828	1-249-429-11	CARBON	10K	5% 1/4W
R829	1-249-429-11	CARBON	10K	5% 1/4W
R830	1-249-429-11	CARBON	10K	5% 1/4W
R831	1-249-429-11	CARBON	10K	5% 1/4W
R832	1-249-429-11	CARBON	10K	5% 1/4W

< VARIABLE RESISTOR >

RV101	1-238-601-11	RES, ADJ, CARBON	22K	
RV102	1-238-602-11	RES, ADJ, CARBON	47K	
RV103	1-238-601-11	RES, ADJ, CARBON	22K	
RV121	1-238-599-11	RES, ADJ, CARBON	4.7K	
RV201	1-238-601-11	RES, ADJ, CARBON	22K	

MAIN PANEL SW-A

Ref. No.	Part No.	Description	Remark
RV202	1-238-602-11	RES. ADJ. CARBON 47K	
RV203	1-238-601-11	RES. ADJ. CARBON 22K	
RV221	1-238-599-11	RES. ADJ. CARBON 4.7K	
RV306	1-223-387-21	RES. ADJ. CARBON 330K	
< TRANSFORMER >			
T101	1-433-344-11	TRANSFORMER. BIAS OSCILLATION	
T201	1-433-344-11	TRANSFORMER. BIAS OSCILLATION	
T301	1-423-614-11	TRANSFORMER. BIAS OSCILLATION	
< TEST PIN >			
* TP301	1-564-506-11	PLUG. CONNECTOR 3P	
* TP801	1-564-505-11	PLUG. CONNECTOR 2P	
< CRYSTAL >			
X801	1-579-175-11	VIBRATOR, CERAMIC	

*	A-2007-007-A	PANEL BOARD, COMPLETE (K411)	

*	A-2007-010-A	PANEL BOARD, COMPLETE (K511S)	

*	3-386-245-01	HOLDER (FL)	
< CONNECTOR >			
* CNP903	1-568-845-11	SOCKET, CONNECTOR 31P	
* CNP904	1-568-830-11	SOCKET, CONNECTOR 11P	
* CNP906	1-568-824-11	SOCKET, CONNECTOR 5P	
* CNP907	1-568-824-11	SOCKET, CONNECTOR 5P	
< IC >			
IC901	8-741-100-48	IC SBX1610-59	
< RESISTOR >			
R153	1-249-425-11	CARBON 4.7K 5%	1/4W
R253	1-249-425-11	CARBON 4.7K 5%	1/4W
R362	1-249-429-11	CARBON 10K 5%	1/4W
R901	1-247-838-00	CARBON 2K 5%	1/4W
R902	1-249-422-11	CARBON 2.7K 5%	1/4W
R903	1-247-848-11	CARBON 5.1K 5%	1/4W
R904	1-249-430-11	CARBON 12K 5%	1/4W
R905	1-247-866-11	CARBON 30K 5%	1/4W
R906	1-249-422-11	CARBON 2.7K 5%	1/4W
R907	1-249-424-11	CARBON 3.9K 5%	1/4W
R908	1-249-428-11	CARBON 8.2K 5%	1/4W
R909	1-249-434-11	CARBON 27K 5%	1/4W
R910	1-247-838-00	CARBON 2K 5%	1/4W
R911	1-249-422-11	CARBON 2.7K 5%	1/4W

Ref. No.	Part No.	Description	Remark
R912	1-247-848-11	CARBON 5.1K 5%	1/4W
R913	1-249-430-11	CARBON 12K 5%	1/4W
R914	1-247-866-11	CARBON 30K 5%	1/4W
< VARIABLE RESISTOR >			
RV301	1-241-820-11	RES. VAR. CARBON 50K/50K (REC LEVEL)	
RV302	1-241-897-11	RES. VAR. CARBON 50K/50K (BALANCE)	
RV303	1-241-896-11	RES. VAR. CARBON 10K (BIAS)	
RV304	1-223-366-11	RES. VAR. CARBON 5K/5K (REC LEVEL)	
< SWITCH >			
S901	1-554-303-21	SWITCH, TACTILE (▷)	
S902	1-554-303-21	SWITCH, TACTILE (PAUSE:)	
S903	1-554-303-21	SWITCH, TACTILE (RESET)	
S904	1-554-303-21	SWITCH, TACTILE (MEMORY)	
S905	1-554-303-21	SWITCH, TACTILE (MONITOR)	
S906	1-554-303-21	SWITCH, TACTILE (■)	
S907	1-554-303-21	SWITCH, TACTILE (◀)	
S908	1-554-303-21	SWITCH, TACTILE (▷▷)	
S909	1-554-303-21	SWITCH, TACTILE (REC)	
S910	1-554-303-21	SWITCH, TACTILE (REC MUTE)	
S911	1-554-303-21	SWITCH, TACTILE (CALIBRATION)	
S921	1-692-409-11	SWITCH, PUSH (1 KEY) (POWER)	
S922	1-554-118-00	SWITCH, PUSH (1 KEY) (MPX FILTER)	
S923	1-692-408-11	SWITCH, ROTARY (DOLBY NR) (K411)	
S923	1-692-410-11	SWITCH, ROTARY (DOLBY NR) (K511S)	
< FILTER >			
VFD901	1-517-163-11	INDICATOR TUBE, FLUORESCENT	

*	1-634-841-14	SW-A BOARD	

	3-343-419-01	HOLDER (S SENSBR A)	
< CONNECTOR >			
* CNP81	1-568-852-11	SOCKET, CONNECTOR 9P	
< IC >			
IC81	8-719-710-03	DIODE NJL5165K-B	
IC82	8-719-710-03	DIODE NJL5165K-B	
< RESISTOR >			
R81	1-249-414-11	CARBON 560 5%	1/4W
R83	1-247-834-11	CARBON 1.3K 5%	1/4W
R84	1-249-417-11	CARBON 1K 5%	1/4W
R85	1-249-408-11	CARBON 180 5%	1/4W
R86	1-249-408-11	CARBON 180 5%	1/4W

Ref. No.	Part No.	Description	Remark
< SWITCH >			
S81	1-571-958-11	SWITCH, PUSH (1 KEY) (STOP SW)	
S82	1-571-281-21	SWITCH, LEAF (CrO2)	
S83	1-571-281-21	SWITCH, LEAF (METAL)	
S84	1-571-281-21	SWITCH, LEAF (REC)	
S86	1-571-281-21	SWITCH, LEAF (HALF)	

MISCELLANEOUS

△5	1-575-651-21	CORD, POWER (AEP, Germany)	
△5	1-696-586-11	CORD, POWER (UK)	
△5	1-696-845-11	CORD, POWER (AUS)	
64	1-751-097-11	WIRE (FLAT TYPE) (11 CORE)	
65	1-751-096-11	WIRE (FLAT TYPE) (31 CORE)	
71	1-575-781-11	WIRE, FLAT TYPE (9 CORE)	
72	1-575-780-11	WIRE, FLAT TYPE (7 CORE)	
77	1-575-778-11	WIRE, FLAT TYPE (5 CORE)	
78	1-751-098-11	WIRE (FLAT TYPE) (5 CORE)	
120	1-638-983-11	PC BOARD, MOTOR FLEXIBLE	
△F701	1-532-285-00	FUSE, TIME-LAG	
△F702	1-532-285-00	FUSE, TIME-LAG	
HE101	1-543-673-11	HEAD, MAGNETIC (ERASE)	
HRP101	1-543-733-11	HEAD, MAGNETIC (RECORD/PLAYBACK)	
M1	X-3363-501-1	MOTOR ASSY, REEL	
M2	X-3365-377-1	MOTOR ASSY, CAPSTAN	
Q703	8-729-141-83	TRANSISTOR 2SB1094-LK	
Q704	8-729-141-89	TRANSISTOR 2SD1585-K	
Q705	8-729-209-15	TRANSISTOR 2SD2012	
△T701	1-423-613-11	TRANSFORMER, POWER	

ACCESSORIES & PACKING MATERIALS

	1-558-271-11	CORD, CONNECTION	
	1-558-271-11	CORD, CONNECTION	
	1-696-170-11	CORD, CONNECTION	
*	3-350-830-01	CUSHION	
*	3-388-323-51	INDIVIDUAL CARTON (K511S)	
*	3-388-323-61	INDIVIDUAL CARTON (K411)	
	3-756-691-11	MANUAL, INSTRUCTION (AEP) (ENGLISH/FRENCH/SPANISH/PORTUGUESE)	
	3-756-691-41	MANUAL, INSTRUCTION (AEP) (GERMAN/DUTCH/SWEDISH/ITALIAN)	
	3-756-691-51	MANUAL, INSTRUCTION (GERMAN) (Germany)	
	3-756-691-61	MANUAL, INSTRUCTION (ENGLISH) (US, AUS)	
	3-756-691-71	MANUAL, INSTRUCTION (DANISH/FINNISH) (AEP)	

Ref. No.	Part No.	Description	Remark
***** HARDWARE LIST *****			
#1	7-682-548-09	SCREW +BVTT 3X8 (S)	
#2	7-682-547-09	SCREW +BVTT 3X6 (S)	
#3	7-621-849-00	SCREW (BV/RING)	
#4	7-621-773-95	SCREW +BVTT 2.6X6 (S)	
#5	7-685-134-19	SCREW (+ PTPWH) (2.6X8)	
#6	7-621-775-00	SCREW +B 2.6X3	
#7	7-627-556-08	SCREW +P 2.6X2.8	
#8	7-621-772-10	SCREW +B 2X4	

The components identified by mark △ or dotted line with mark △ are critical for safety. Replace only with part number specified.

