

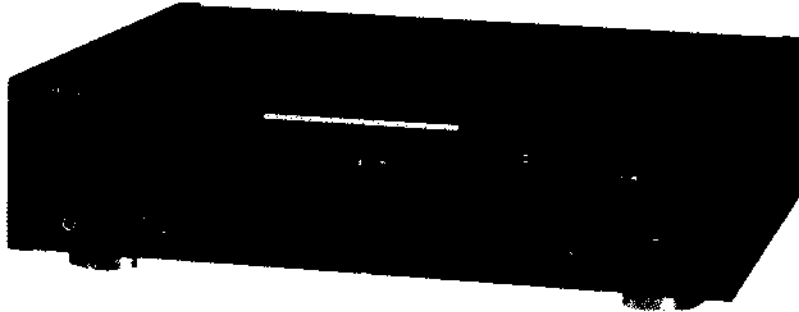

# TC-K333ESR / K730ES

## SERVICE MANUAL

US Model  
 Canadian Model  
 AEP Model  
 UK Model  
 TC-K730ES  
 E Model  
 TC-K333ESR



Dolby noise reduction manufactured under license from Dolby Laboratories Licensing Corporation. "DOLBY" and the double-D symbol  are trademarks of Dolby Laboratories Licensing Corporation.

This photo is TC-K333ESR

### SPECIFICATIONS

Model Name Using Similar Mechanism	NEW
Tape Transport Mechanism Type	TCM-110D3

Recording system 4-track 2-channel stereo  
 Bias frequency 210 kHz  
 Heads Erase head × 1 (S & F head)  
 Record head × 1 (LA head)  
 Playback head × 1 (LA head)  
 Motors Capstan motor × 1 (direct drive linear torque BSL motor)  
 Reel motor × 1 (DC motor)  
 Wow and flutter ±0.04% W.peak (IEC)  
 0.025% WRMS  
 Fast-forward and rewind time  
 Approx. 90 sec (with C-60 cassette)  
 Frequency response  
 Dolby NR OFF  
 TYPE IV cassette (Sony METAL-ES)  
 20 – 21,000 Hz ±3 dB (DIN)  
 20 – 16,000 Hz ±3 dB (0 VU recording level)  
 15 – 22,000 Hz  
 TYPE II cassette (Sony UX-S)  
 20 – 19,000 Hz ±3 dB (DIN)  
 15 – 20,000 Hz  
 TYPE I cassette (Sony HF-S)  
 20 – 17,000 Hz ±3 dB (DIN)  
 15 – 19,000 Hz

Signal-to-noise ratio (at peak level)

Cassette	TYPE I (Sony HF-S)	TYPE II (Sony UX-S)	TYPE IV (Sony METAL-ES)
Dolby NR system			
C-TYPE ON	69 dB	72 dB	73 dB
B-TYPE ON	63 dB	66 dB	67 dB
OFF	56 dB	59 dB	60 dB

Total harmonic distortion 0.8% (with Sony METAL-ES cassette)  
 Inputs Line inputs (phono jacks)  
 Sensitivity 77.5 mV  
 Input impedance 50 k ohms  
 Outputs Line outputs (phono jacks)  
 Rated output level 0.44 V (–5 dB) at load impedance 47 k ohms  
 Minimum load impedance 10 k ohms  
 Headphones output (stereo phone jack)  
 Output level continuously variable from 0 – 3 mW (at load impedance 32 ohms)

#### General

Power requirements  
 US, Canadian model: 120V AC, 60Hz  
 UK model: 240V AC, 50Hz  
 (220V AC adjustable by authorized Sony personnel)  
 AEP model: 220V AC, 50/60 Hz  
 (240V AC adjustable by authorized Sony personnel)  
 E model: 120, 220 or 240V AC adjustable, 50/60Hz  
 Power consumption 30 watts  
 Dimensions Approx. 470 × 125 × 350 mm (w/h/d)  
 (18<sup>3</sup>/<sub>8</sub> × 5 × 13<sup>3</sup>/<sub>4</sub> inches)  
 Weight Approx. 9.5 kg (22 lb)  
 Supplied accessories  
 Connecting cord (2)  
 Screws (8)

— continued on next page —

STEREO CASSETTE DECK  
**SONY**<sup>®</sup>



**Peak program meters**

Display range -40 to +8 dB  
 Frequency response 20 - 20,000 Hz ±1.5 dB  
 Attack time 1 ms  
 Recovery time 750 ms (from 0 to -20 dB)  
 Number of display segments 16 each for left and right channel

Design and specifications are subject to change without notice.

**Note**

This appliance conforms with EEC Directives 76/889 and 82/499 regarding interference suppression.

**TABLE OF CONTENTS**

<u>Section</u>	<u>Title</u>	<u>Page</u>
<b>1. GENERAL</b>		
1-1.	Location and Function of Controls .....	3
<b>2. MECHANICAL ADJUSTMENTS</b>	.....	4
<b>3. ELECTRICAL ADJUSTMENTS</b>	.....	7
<b>4. DIAGRAMS</b>		
4-1.	Semiconductor Lead Layouts .....	16
4-2.	Printed Wiring Board —Audio Section— .....	17
4-3.	Schematic Diagram —Audio Section— .....	21
4-4.	Printed Wiring Board —System Control Section— ..	25
4-5.	Schematic Diagram —System Control Section— .....	29
<b>5. EXPLODED VIEWS</b>		
5-1.	Case .....	33
5-2.	Front Panel .....	34
5-3.	Chassis .....	35
5-4.	Mechanism Section (1) .....	36
5-5.	Mechanism Section (2) .....	38
<b>6. ELECTRICAL PARTS LIST</b>	.....	40

**SAFETY-RELATED COMPONENT WARNING!!**

COMPONENTS IDENTIFIED BY SHADING AND MARK  ON THE SCHEMATIC DIAGRAMS AND IN THE PARTS LIST ARE CRITICAL TO SAFE OPERATION. REPLACE THESE COMPONENTS WITH SONY PARTS WHOSE PART NUMBERS APPEAR AS SHOWN IN THIS MANUAL OR IN SUPPLEMENTS PUBLISHED BY SONY.

**OPERATING VOLTAGE**

Before connecting the unit to the power source, check that the operating voltage of your unit is the same as the local power line voltage.

The USA and Canada model operates on 120 V AC.

The European model operates on 220 V AC (or 240 V AC adjustable by authorized Sony personnel).

The United Kingdom model operates on 240 V AC (or 220 V AC adjustable by authorized Sony personnel).

The model for other countries operates on 120, 220 or 240 V AC. The voltage selector is located on the rear panel. If the selector must be reset, **disconnect the AC power cord** and set the selector to the appropriate voltage.

**MODEL IDENTIFICATION**

— Specification Label —

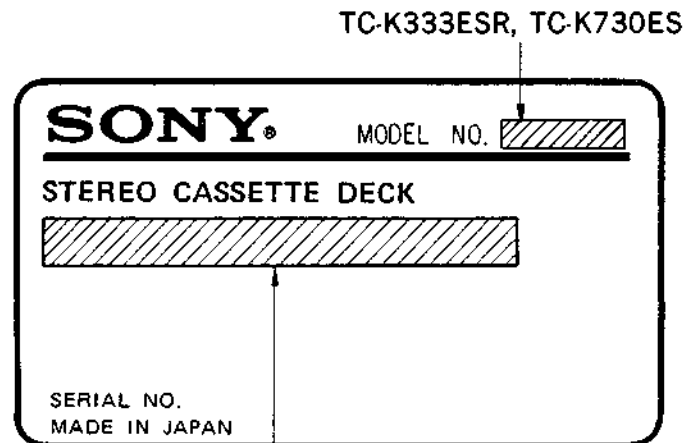

AEP Model: AC: 220 V~50/60 Hz

UK Model: AC: 240 V~50/60 Hz

E Model: AC: 120/220/240 V~50/60 Hz 30 W

US Model: AC: 120 V 60 Hz 30 W

Canadian Model: AC: 120 V 60 Hz 30 W

**ATTENTION AU COMPOSANT AYANT RAPPORT À LA SÉCURITÉ!**

LES COMPOSANTS IDENTIFIÉS PAR UNE TRAME ET UNE MARQUE  SUR LES DIAGRAMMES SCHEMATIQUES ET LA LISTE DES PIÈCES SONT CRITIQUES POUR LA SÉCURITÉ DE FONCTIONNEMENT. NE REMPLACER CES COMPOSANTS QUE PAR DES PIÈCES SONY DONT LES NUMÉROS SONT DONNÉS DANS CE MANUEL OU DANS LES SUPPLÉMENTS PUBLIÉS PAR SONY.

**SECTION 1  
GENERAL**

**1-1. LOCATION AND FUNCTION OF CONTROLS**

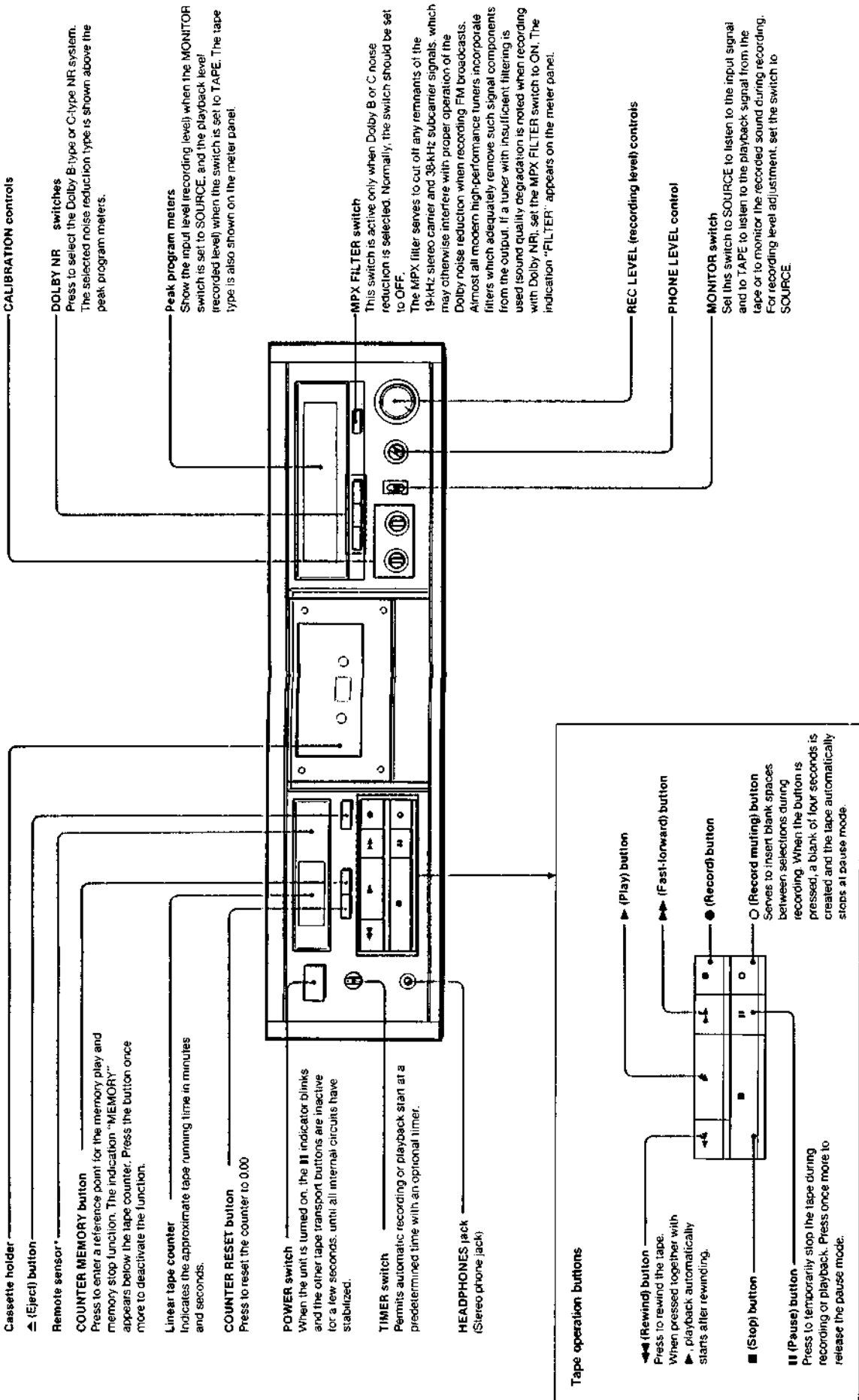

## SECTION 2 MECHANICAL ADJUSTMENTS

### PRECAUTION

1. Clean the following parts with a denatured-alcohol-moistened swab:
 

record/playback head	pinch roller
erase head	rubber belts
capstan	idlers
2. Demagnetize the record/playback and erase head with a head demagnetizer.
3. Do not use a magnetized screwdriver for the adjustments.
4. After the adjustments, apply suitable locking compound to the parts adjusted.
5. The adjustments should be performed with the rated power supply voltage unless otherwise noted.

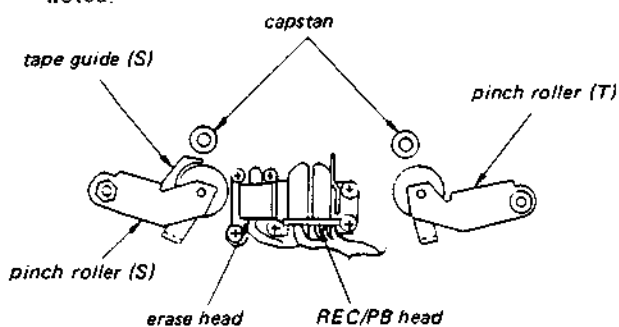

#### FF, REW Torque Check

1. Insert the torque meter CQ201B.
2. Check FF torque when changing the mode STOP → FF.
3. Check REW torque when changing the mode STOP → REW.

Torque	Torque meter	Reading
FF, REW	CQ201B	60 to 130 g·cm (0.84 to 1.82 oz·inch)

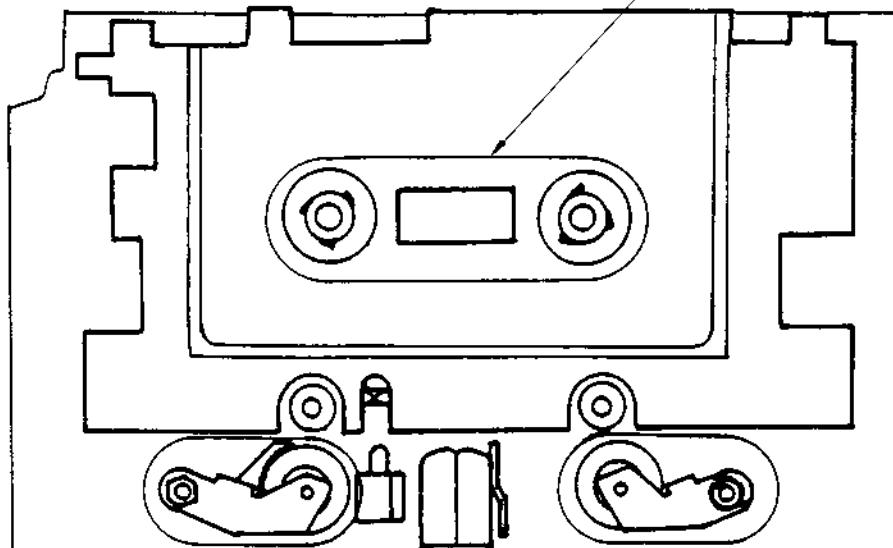

**Head Height Adjustment**

Insert a mirror cassette or adjustment cassette and adjust screws **A** - **C** so that the tape enters the tape guide of the record/playback head smoothly when pushing the head base out by hand.

1. Make an adjustment cassette as shown below or use a mirror cassette.

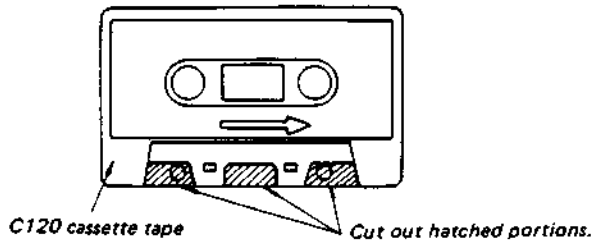

2. Insert the mirror cassette (or adjustment cassette) into the set. In FWD mode, the tape should not curl at the portions shown by arrows (tape guides) in Fig. a. If it does, adjust the height of tape guide of supply pinch roller.

**Adjustment locations:**

adjustment screw of tape curl in Fig. b  
(Be careful not to turn the screw more than 1/2 turn.)

3. Back tension: 0

Make sure that there is no tape twist at portions **a** - **f**.

1. When the tape twists upwards:  
Turn adjustment screws **B**, **C** of the record/playback head and recline the head as shown in Fig. c.

2. When the tape twists downwards:  
Turn adjustment screws **B**, **C** and recline the head as shown in Fig. d.

4. Measure the height of erase head.  
If it is out of the range indicated in Fig. e, follow the procedures below.

1. When the height of erase head is out of the range:

Adjust the height by screws **D**, **E**, **F** of the erase head.

2. After adjusting the height of the erase head, make sure that the head is not inclined. If necessary, loosen or tighten adjustment screw **D**.

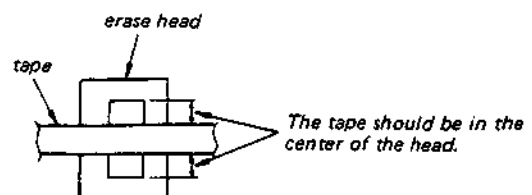
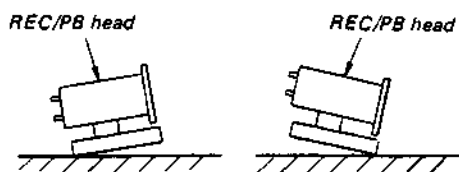
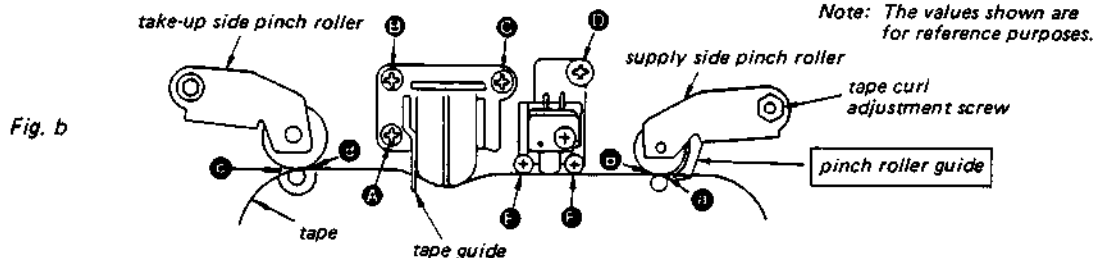
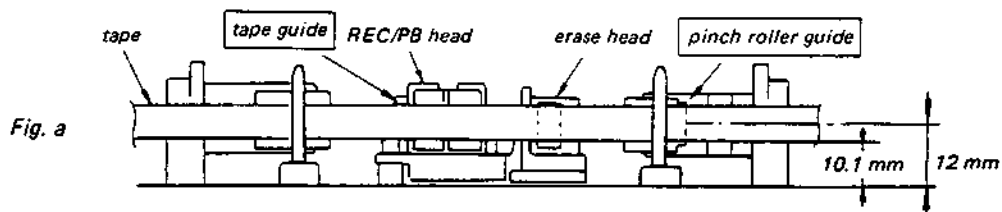

**Forward Torque/Back Tension Torque Adjustment**

1. Insert the taken-up tape, and set the Forward mode. Adjust RV701 so that the A begins to rotate.

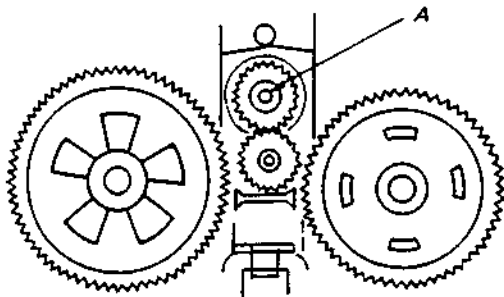

2. Insert the torque meter CQ102C, make sure that the forward torque and the back tension torque meet the specifications.

**Specifications**

Forward torque: 30 to 60 g-cm  
(0.42 to 0.84 oz-inch)

Forward back tension torque:  
7 to 10.5 g-cm  
(0.1 to 0.15 oz-inch)

3. When the forward back tension torque doesn't meet the specifications, adjust by changing the hooking position of the spring as shown below.

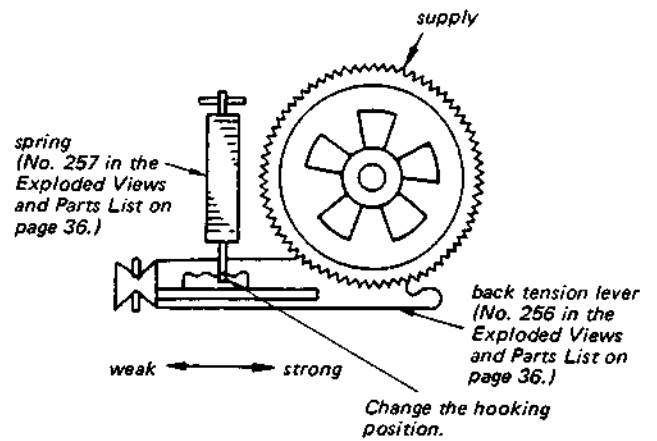

**Adjustment Location:** system control board

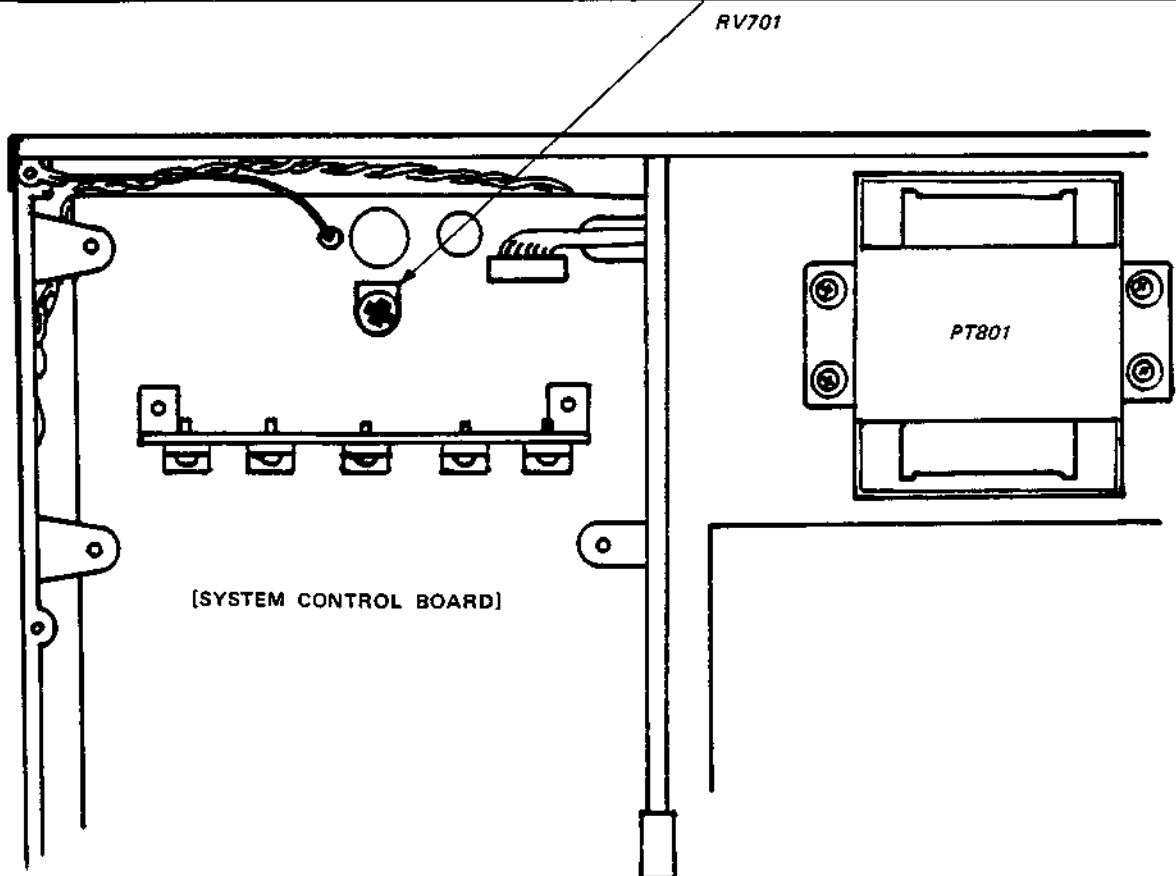

## SECTION 3 ELECTRICAL ADJUSTMENTS

**Note:** The adjustment should be performed in the order given in this service manual.  
The adjustments should be performed for both L-CH and R-CH.

- **Simultaneous REC/PB Mode:**  
Input the signals to **LINE IN** terminal and set to REC mode. Set the monitor switch to TAPE, and monitor the recorded signal from **LINE OUT** terminal.
- **Switch Position:**  
DOLBY NR . . . . . OFF  
NPX FILTER . . . . . OFF  
TIMER . . . . . OFF
- **Standard Record:**  
Deliver the standard input signal level to the input jack and set the **REC LEVEL** control to obtain the standard output signal level.

**Standard Input Level**

Input Terminal	LINE IN
source impedance	10 kΩ
input level	0.25 V (-10 dB)

**Standard Output Level**

Output Terminal	LINE OUT
load impedance	47 kΩ
output level	0.44 V (-5 dB)

**Tape Speed/WOW Check**

**Procedure:**

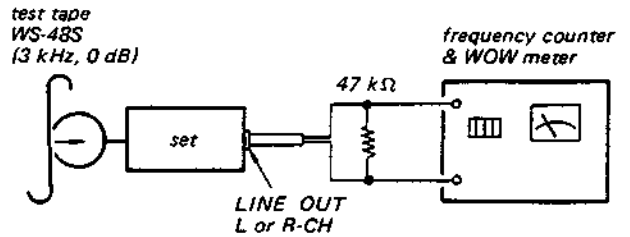

1. Measure the output frequency and the WOW value while playing back the tape top of the test tape.
2. Turn over the test tape, measure the output frequency and the WOW value, and check the difference against the values of the step 1.

**Specification:**

TAPE SPEED deviation: within 2,990 to 3,010 Hz  
 TAPE SPEED fluctuating width: within 2,990 to 3,010 Hz  
 WOW (WRMS): 0.037% below

**Provisional Playback Head Azimuth Adjustment**

**Procedure:**

1. Mode: playback

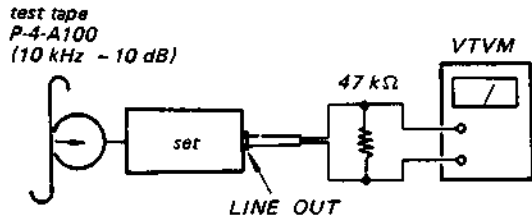

2. Turn the adjustment lock-nut for the maximum output levels. If these levels do not match, turn the adjustment screw until both of output levels match together within 0.5 dB.

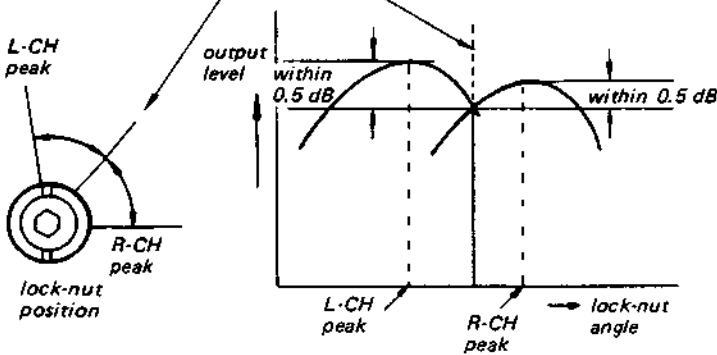

**Adjustment Location:**

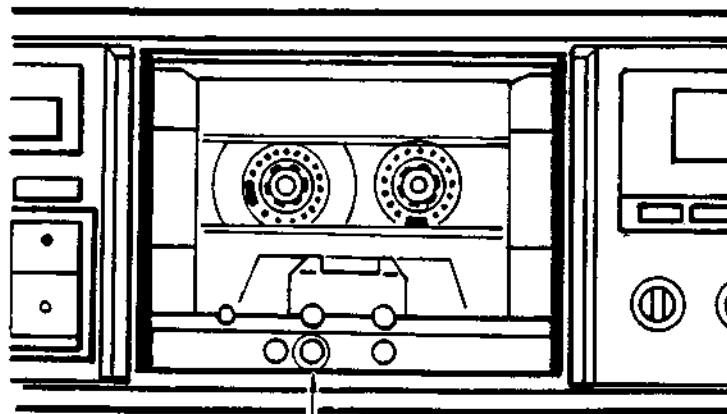

PB head azimuth adjustment screw

3. Phase check.

Mode: playback

test tape  
P-4-A100  
(10 kHz, -10 dB)

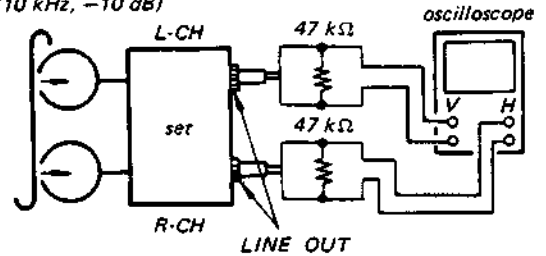

4. Make sure the phase difference is in between in-phase to 90°.

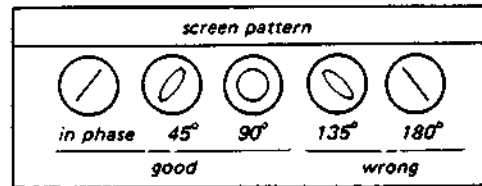



**Playback Level Adjustment**

**Procedure:**

Mode: playback

test tape  
P-4-L300  
(315 Hz, 0 dB)

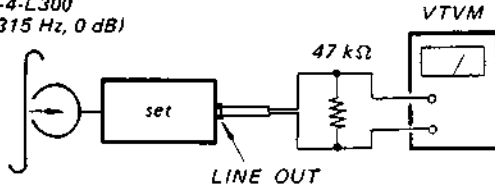

Adjust RV101 (L-CH) and RV201 (R-CH) to obtain the specified LINE OUT level.

**Specification:**

LINE OUT level: 0.41 to 0.46 V  
(-5.5 to -4.5 dB)

Level difference between channels:  
less than 0.5 dB

Check that the LINE OUT level does not change in playback mode while changing the mode from playback to stop several times.

**Adjustment Location:** PB board

**Meter Level Adjustment**

**Setting:**

MONITOR switch: SOURCE

**Procedure:**

1. Stop mode.

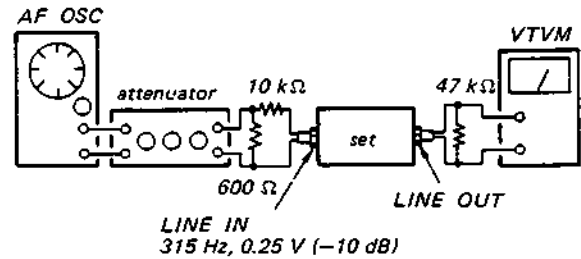

2. Adjust the recording level so that the LINE OUT level is 0.44 V (-5 dB). In this time adjust RV103 (L-CH) and RV203 (R-CH) so that the 0 VU (-4 dB) segments of the meter light-up.

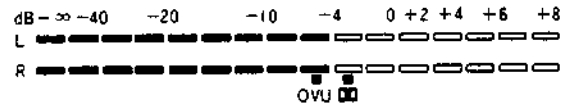

3. Adjust the recording level so that the LINE OUT level is 1.9 V (8 dB). In this time, make sure that all the segments of the meter light-up.

**Adjustment Location:** push switch board

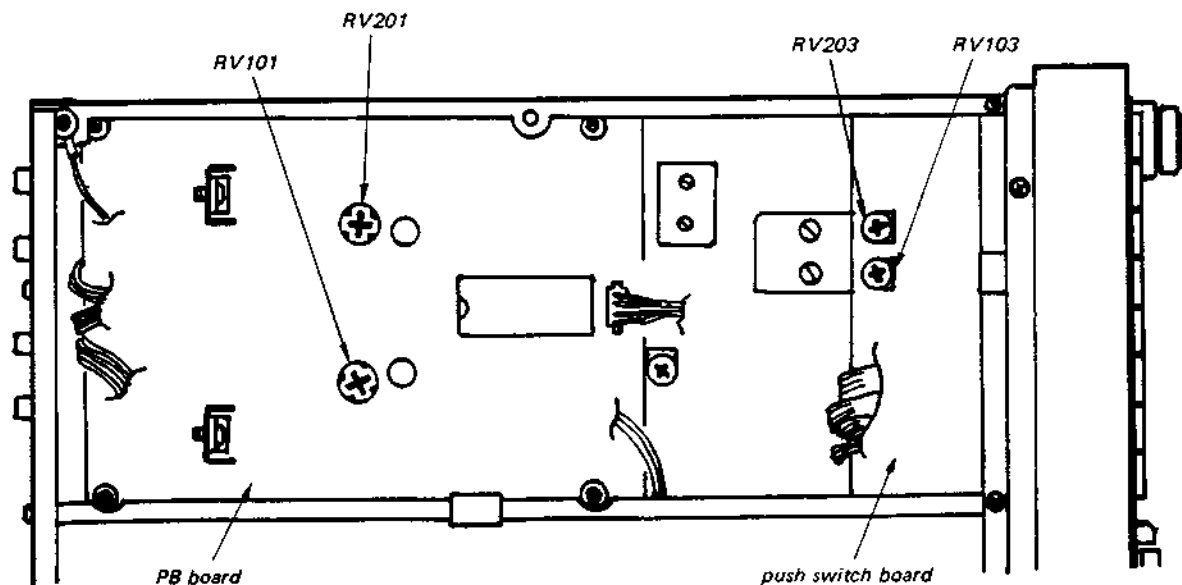

**PB DOLBY NR Check**

**Procedure:**

1. Mode: playback

test tape  
P-4-100  
(10 kHz, -10 dB)

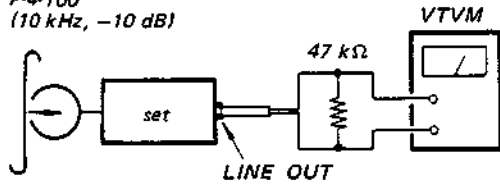

2. Make sure that the output levels are different in DOLBY NR OFF, B, and C.

**Specification:**

- OFF ↔ B level difference -0.5 to -2.5 dB
- B ↔ C level difference -0.5 to -2.5 dB

**MPX FILTER Check**

**Procedure:**

1. Mode: stop

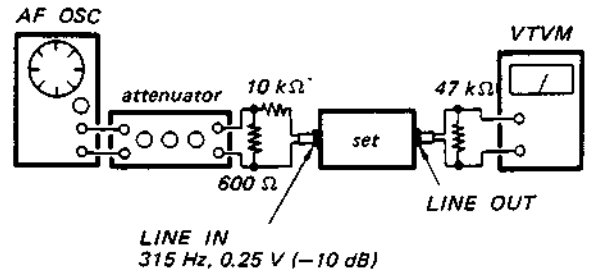

2. Apply 315 Hz, 0.25 V (-10 dB) signal and adjust REC LEVEL control so that the LINE OUT level is 0.44 V (-5 dB).
3. Apply 19 kHz, 0.25 V (-10 dB) signal and measure the LINE OUT level.

**Specification:**

- DOLBY NR: OFF, FILTER: ON/OFF  
0.49 to 0.39 V (-4 to -6 dB)
- DOLBY NR: B, C, FILTER: ON  
0.025 V (-30 dB) or less

**Provisional Record Head Azimuth Adjustment**

**Setting:**

BIAS CAL control: center click  
Turn RV506 (L-CH, R-CH) fully clockwise and counterclockwise 1/2 to 1 time. (See Record Bias Adjustment on page 13.)

**Procedure:**

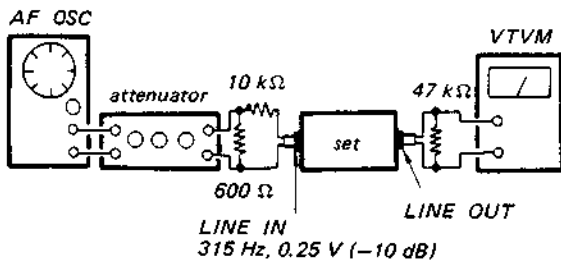

1. Apply 315 Hz, 0.25 V (-10 dB) signal and adjust REC LEVEL control so that the LINE OUT level is 0.44 V (-5 dB).

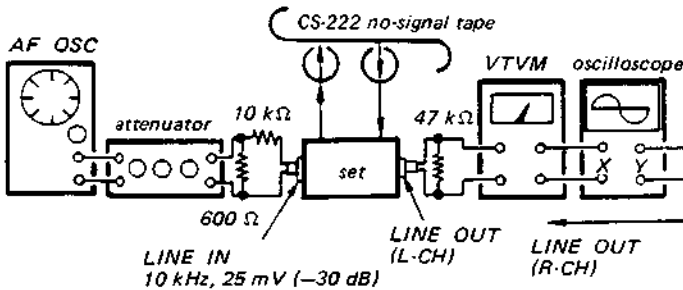

2. Apply 10 kHz, 25 mV (-30 dB) signal, set to the simultaneous REC/PB mode.

**Adjustment Location: REC board**

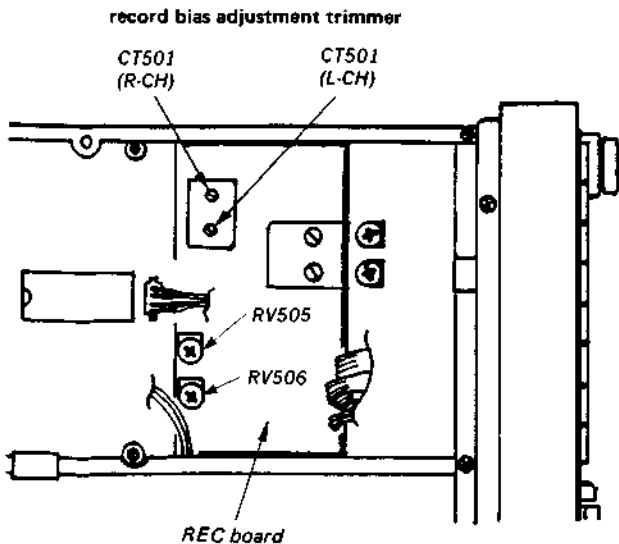

3. Turn the adjustment screw for the maximum output levels. If these levels do not match, turn the adjustment screw until both of output levels match together within 0 dB.

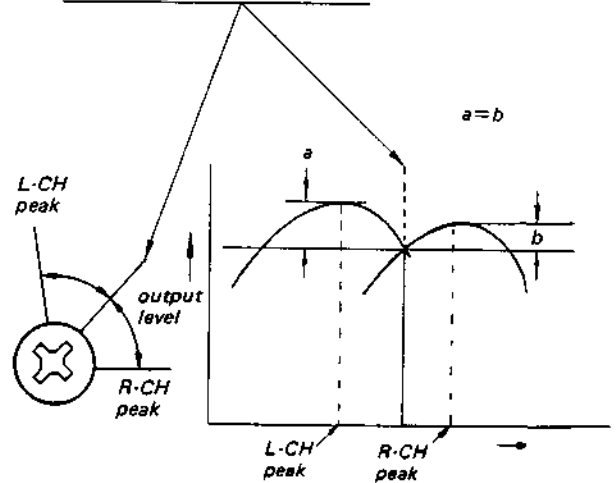

4. Simultaneously, adjust the azimuth screw so that the phase difference between L-CH and R-CH is 0°.

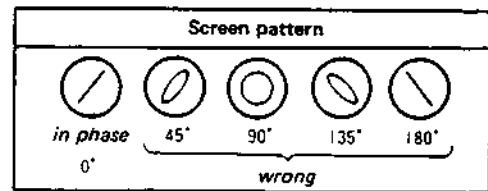

**Adjustment Location: head**

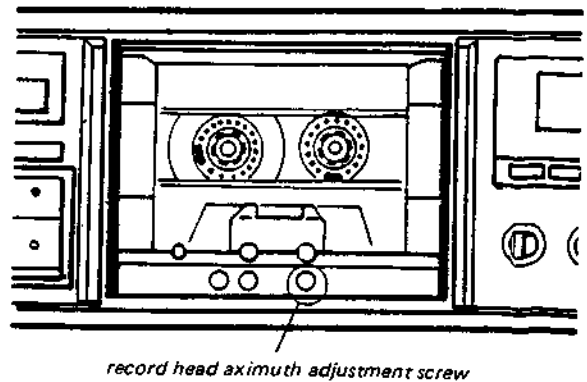

**Bias Osc Frequency Adjustment**

**Setting:**

Metal Tape (TYPE IV)

LINE IN: no signal

REC LEVEL knob: standard record position  
(See page 7.)

• **Bias Osc Frequency**

**Procedure:**

1. Mode: record

*metal tape  
recorded portion*

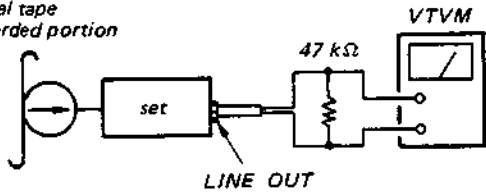

2. Connect the frequency counter lead, to the erase head connecting terminal. Adjust CP501 so that the reading on the frequency counter is 105 kHz (within 104 to 106 kHz).

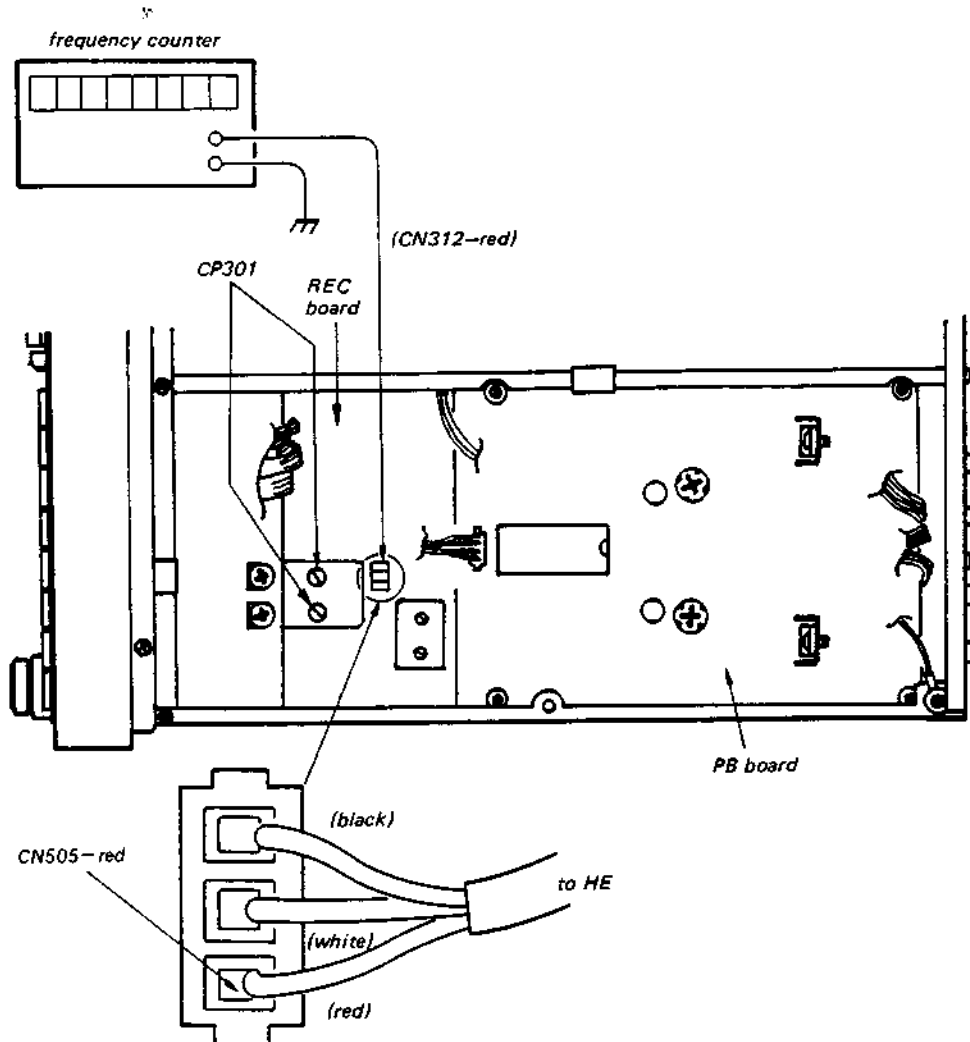

### Record Head Azimuth Adjustment

#### Setting:

REC LEVEL knob: standard record position  
(See page 7.)

#### Procedure:

1. Mode: simultaneous REC/PB

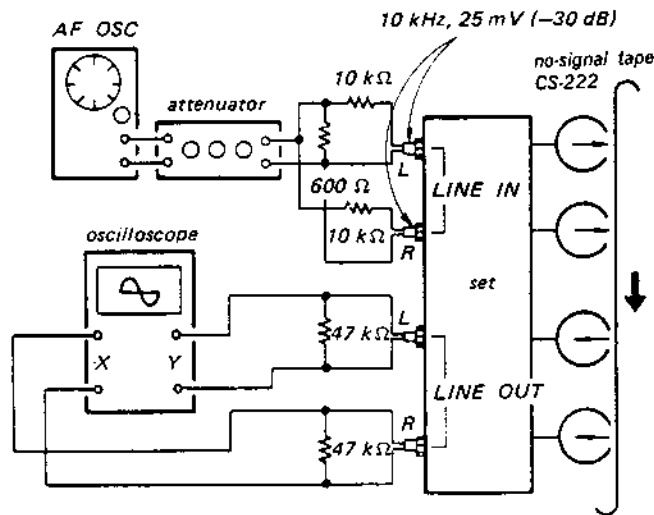

2. Adjust the record head azimuth adjustment screw so that the phase difference is  $0^\circ$  (the difference between L-CH and R-CH is within  $5^\circ$ ), and outputs match within 1 dB from the peak.

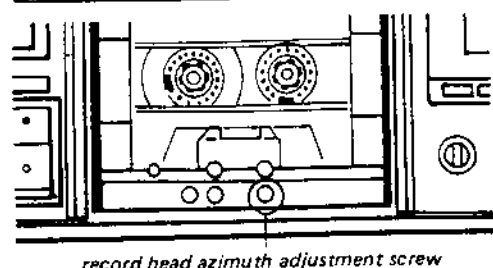
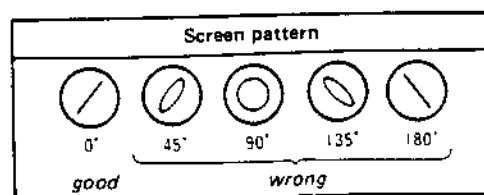
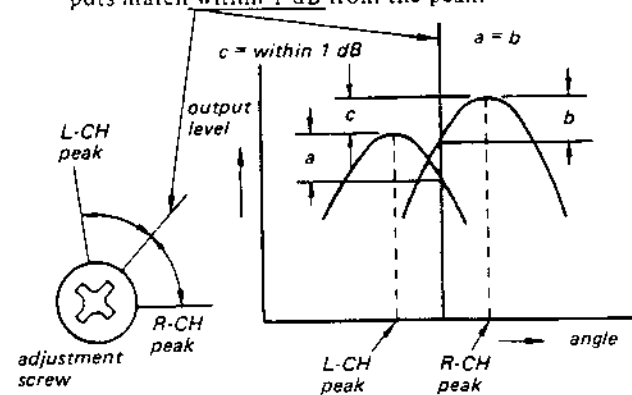

record head azimuth adjustment screw

### Record Bias Adjustment

#### Setting:

REC LEVEL knob: standard record position  
(See page 7.)

#### Procedure:

1. Mode: simultaneous REC/PB

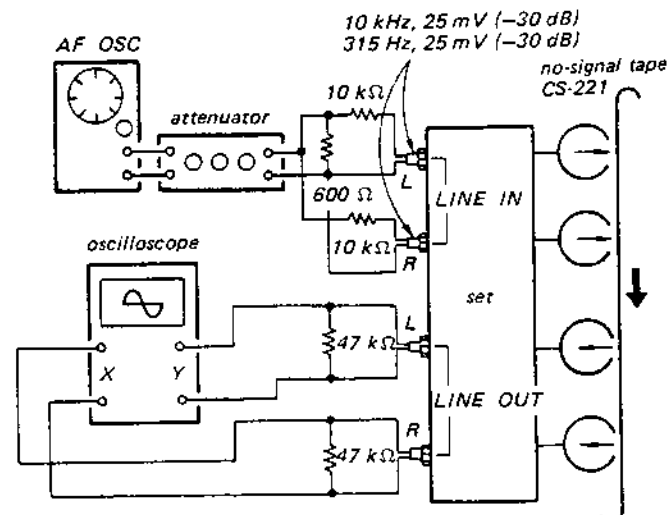

2. Adjust CT501 (L-CH, R-CH) to  $0 \text{ dB} \pm 0.5 \text{ dB}$  playback level at 315 Hz and 10 kHz.

Adjustment Location: REC board

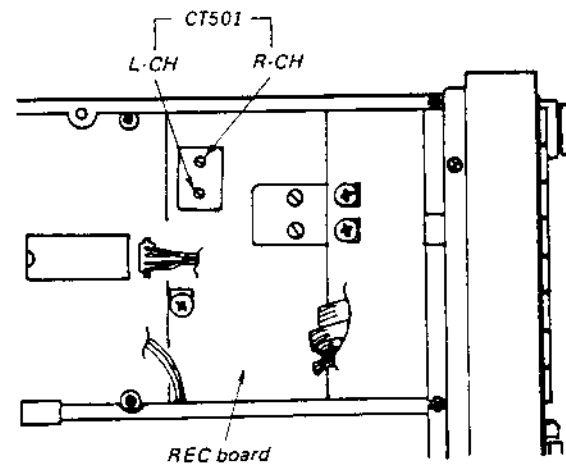

3. After the adjustment, confirm the phase at 10 kHz is  $0^\circ$  (the difference between L-CH and R-CH is within  $30^\circ$ ). Repeat the record head azimuth adjustment and the record bias adjustment satisfy the specification again.

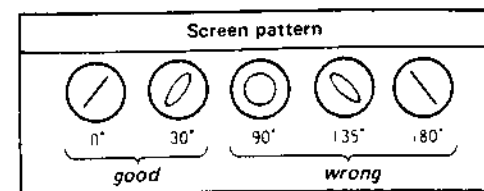

**Note:** For an adjusting trimmer, finish the adjustment within one rotation from the tightly closed state.

If more than one rotation is necessary, remove the bias adjusting tap, and adjust the bias again.

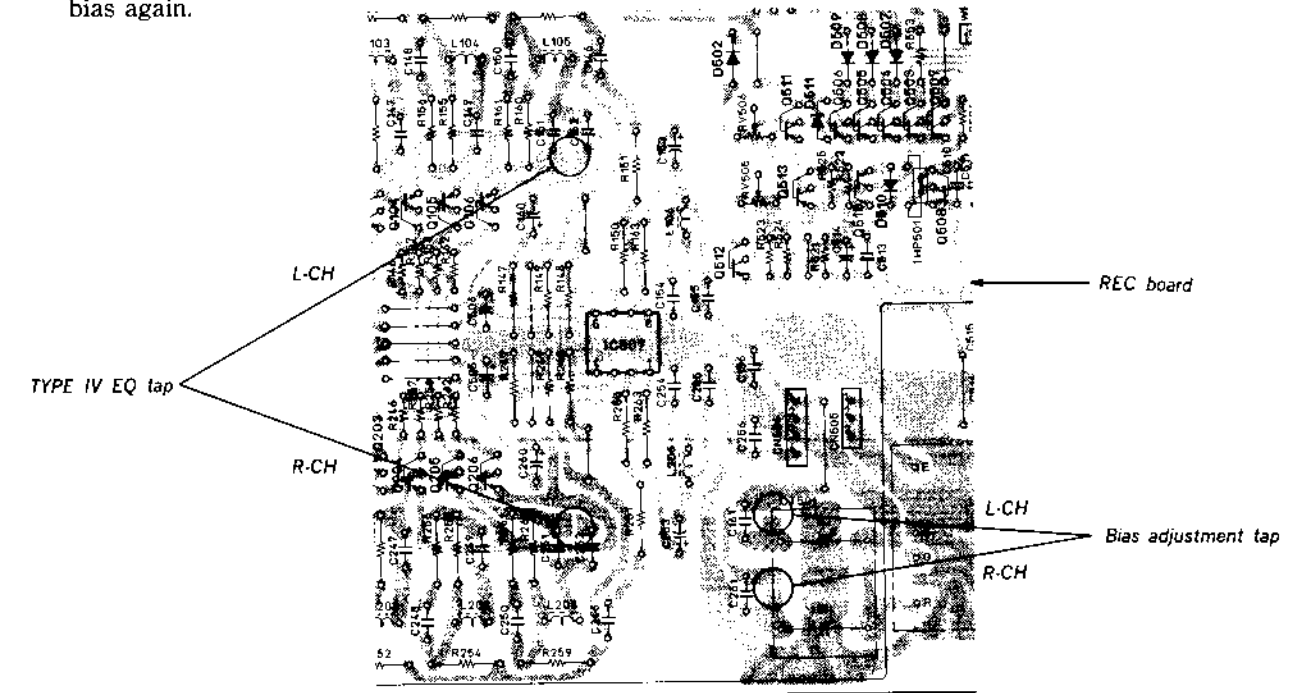

### Normal Bias Adjustment

#### Setting:

REC LEVEL knob: standard record position  
(See page 7.)

#### Procedure:

1. Mode: simultaneous REC/PB

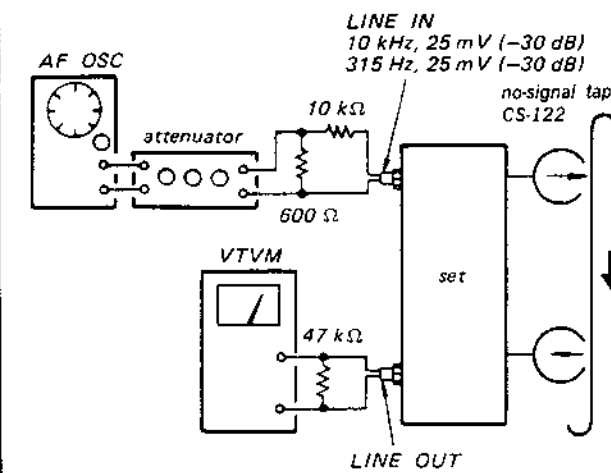

2. Adjust RV505 to obtain the same playback level at 315 Hz and 10 kHz.  
(The difference is within  $0 \text{ dB} \pm 0.5 \text{ dB}$ .)

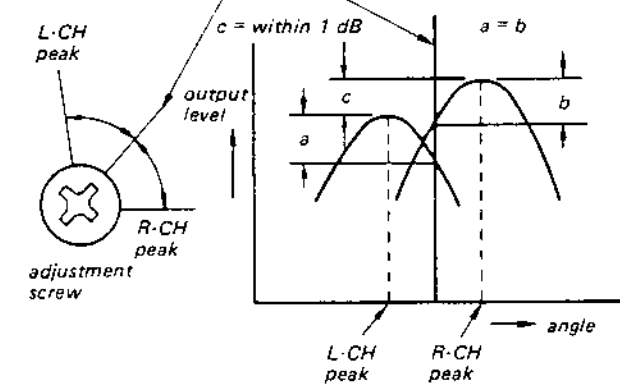

# SECTION 4 DIAGRAMS

## METAL Bias Adjustment

**Setting:**  
REC LEVEL Knob: Standard record position  
(See page 7.)

**Procedure:**  
1. Mode: simultaneous REC/PB

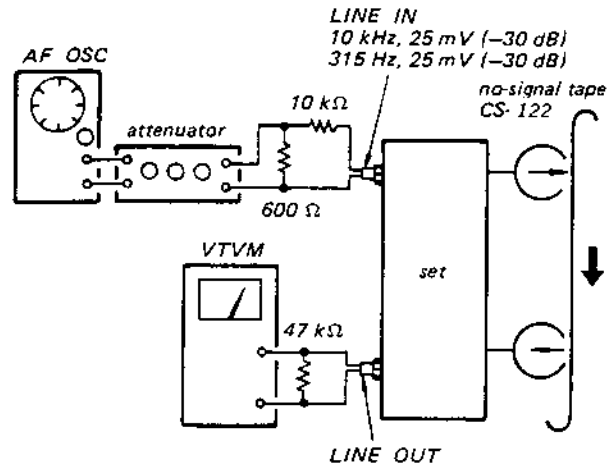

3. After adjustment, check the phase with 10kHz and make re-adjustment at 0° (L-CH, R-CH phase difference: Within  $0 \pm 90^\circ$ ), and repeat the adjustment of bias and recording head vertical adjustment fully.

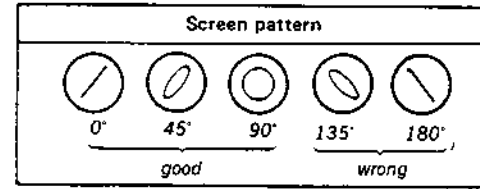

2. Adjust RV506 and TYPE IV EQ tap to obtain the same playback level at 315kHz and 10kHz.  
(The difference is within  $0\text{dB} \pm 1\text{dB}$ .)

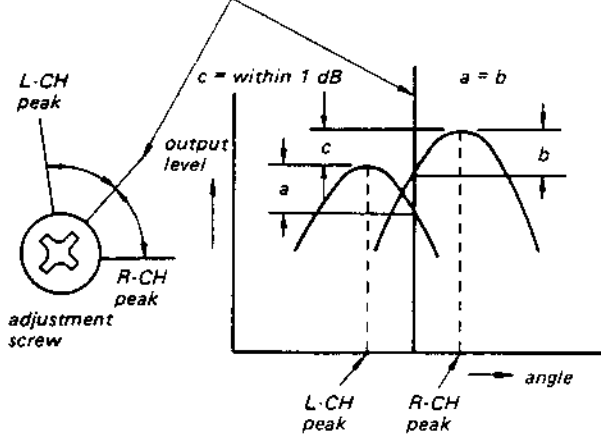

Adjustment Location: REC board

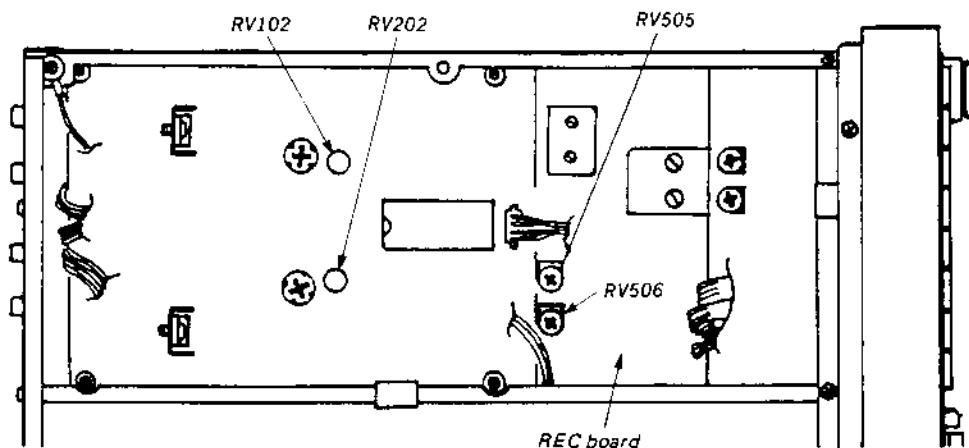

## Record Level Adjustment

**Setting:**  
REC LEVEL knob: standard record position  
(See page 7.)

**Procedure:**  
1. Mode: simultaneous REC/PB

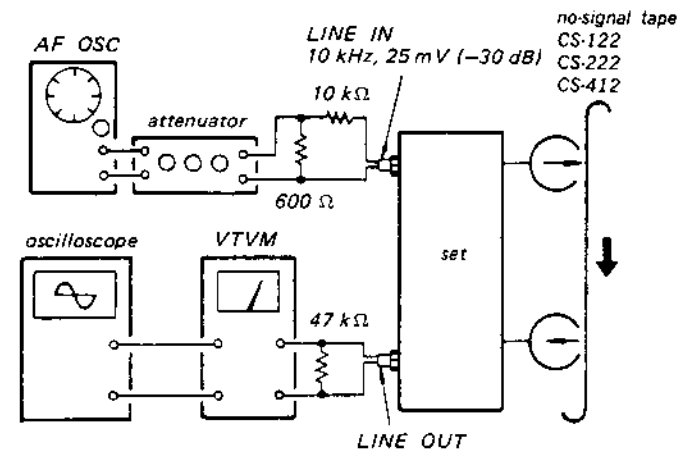

2. Adjust RV102 (L-CH) and RV202 (R-CH) to satisfy the specification.

**Specification:**  
Tape CS-222      within 0.41 to 0.46 V  
                         (Within -5.5 to -4.5 dB)  
Tape CS-122, 412      within 0.39 to 0.49 V  
                         (within -6 to -4 dB)

## 4-1. SEMICONDUCTOR LEAD LAYOUTS

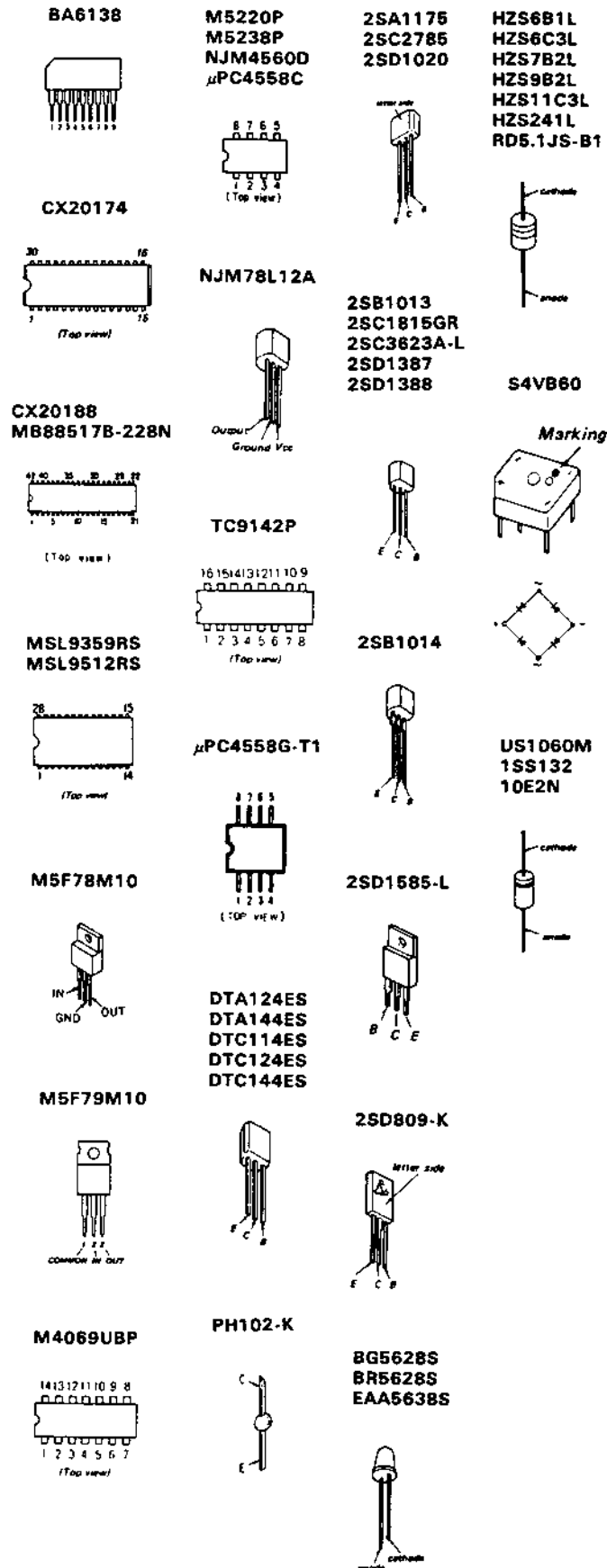

4-2. PRINTED WIRING BOARD—AUDIO SECTION—  
 • Refer to page 16 for Semiconductor Lead Layouts.

• Semiconductor Location

Ref. No.	Location	Ref. No.	Location
IC501	D-5	Q509	F-16
IC502	D-2	Q510	F-15
IC503	E-3	Q511	F-15
IC504	H-3	Q512	G-15
IC505	G-8	Q513	F-15
IC506	G-10	Q514	E-18
IC507	G-14	Q515	G-25
IC508	H-18	Q516	C-22
IC509	F-18	Q517	C-22
IC510	H-23	Q518	C-23
IC511	E-8	Q519	C-22
IC512	C-25	Q520	C-22
		Q521	C-23
Q101	F-5	Q1001	I-5
Q102	G-12	Q1002	J-4
Q103	F-13		
Q104	F-13	D501	E-11
Q105	F-13	D502	F-15
		D503	E-13
Q106	F-13	D504	E-13
Q201	F-1	D505	E-15
Q202	H-12		
Q203	H-13	D506	E-15
Q204	H-13	D507	E-16
		D508	E-15
Q205	H-13	D509	F-15
Q206	H-13	D510	F-16
Q501	E-11		
Q502	E-9	D511	F-15
Q503	F-16	D512	F-17
		D513	H-26
Q504	F-16	D514	B-22
Q505	F-15	D515	B-22
Q506	F-15	D516	C-24
Q507	F-16		
Q508	F-16		

Note:

- — parts extracted from the component side.
- — parts extracted from the conductor side.
- — parts mounted on the conductor side.

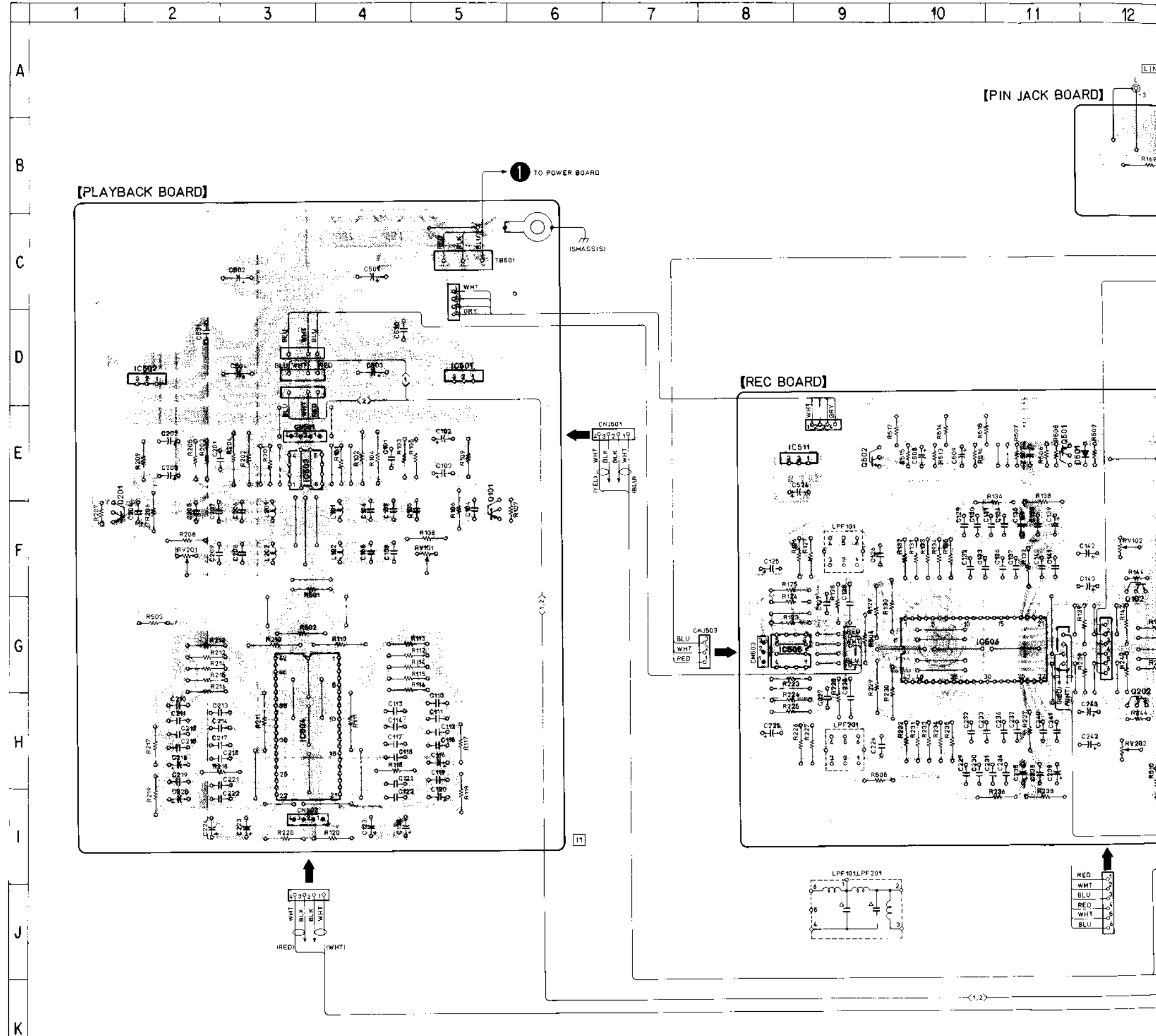

10 11 12 13 14 15 16 17 18 19 20 21 22 23 24 25 26 27

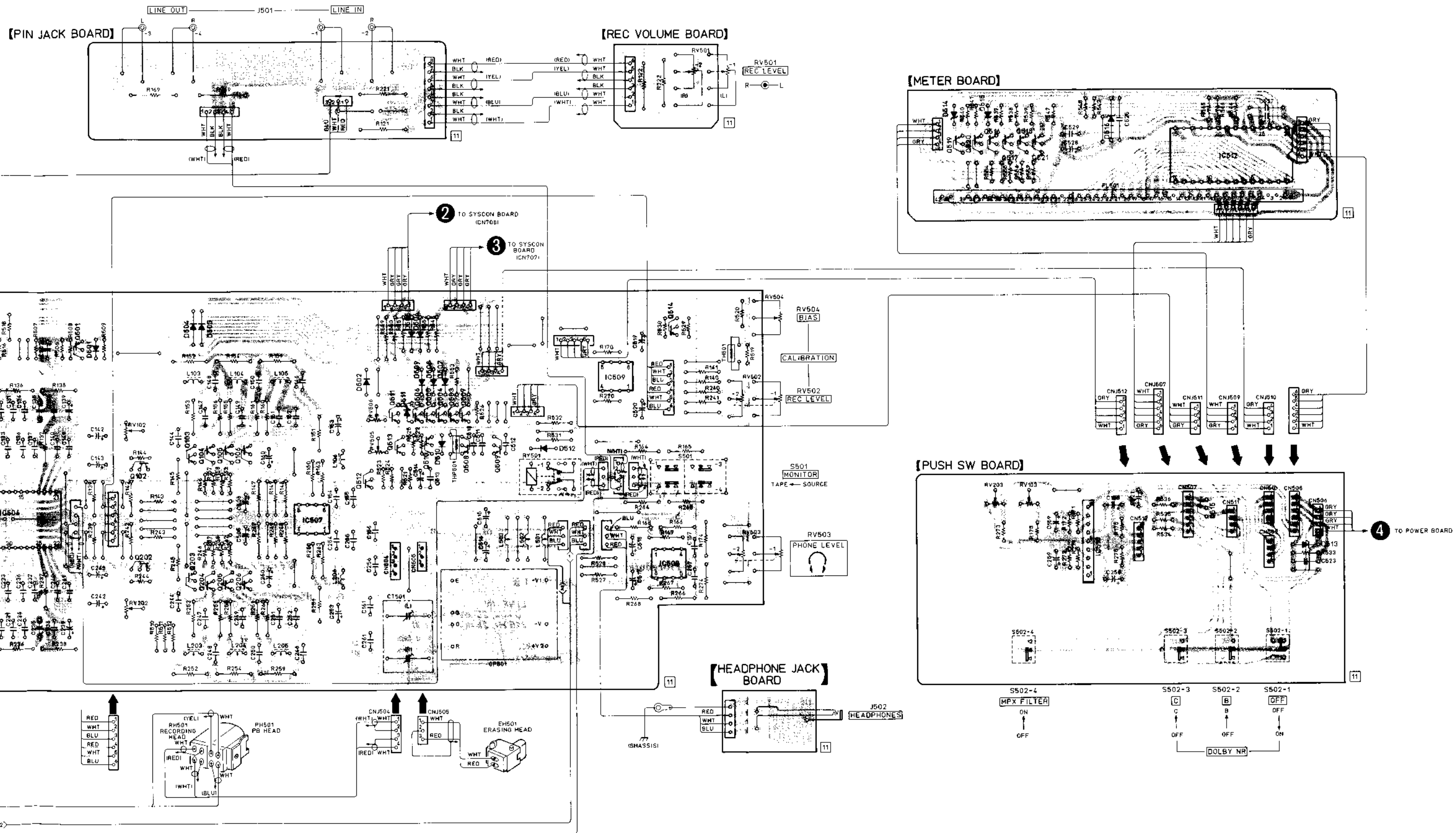



4-3. SCHEMATIC DIAGRAM—AUDIO SECTION—

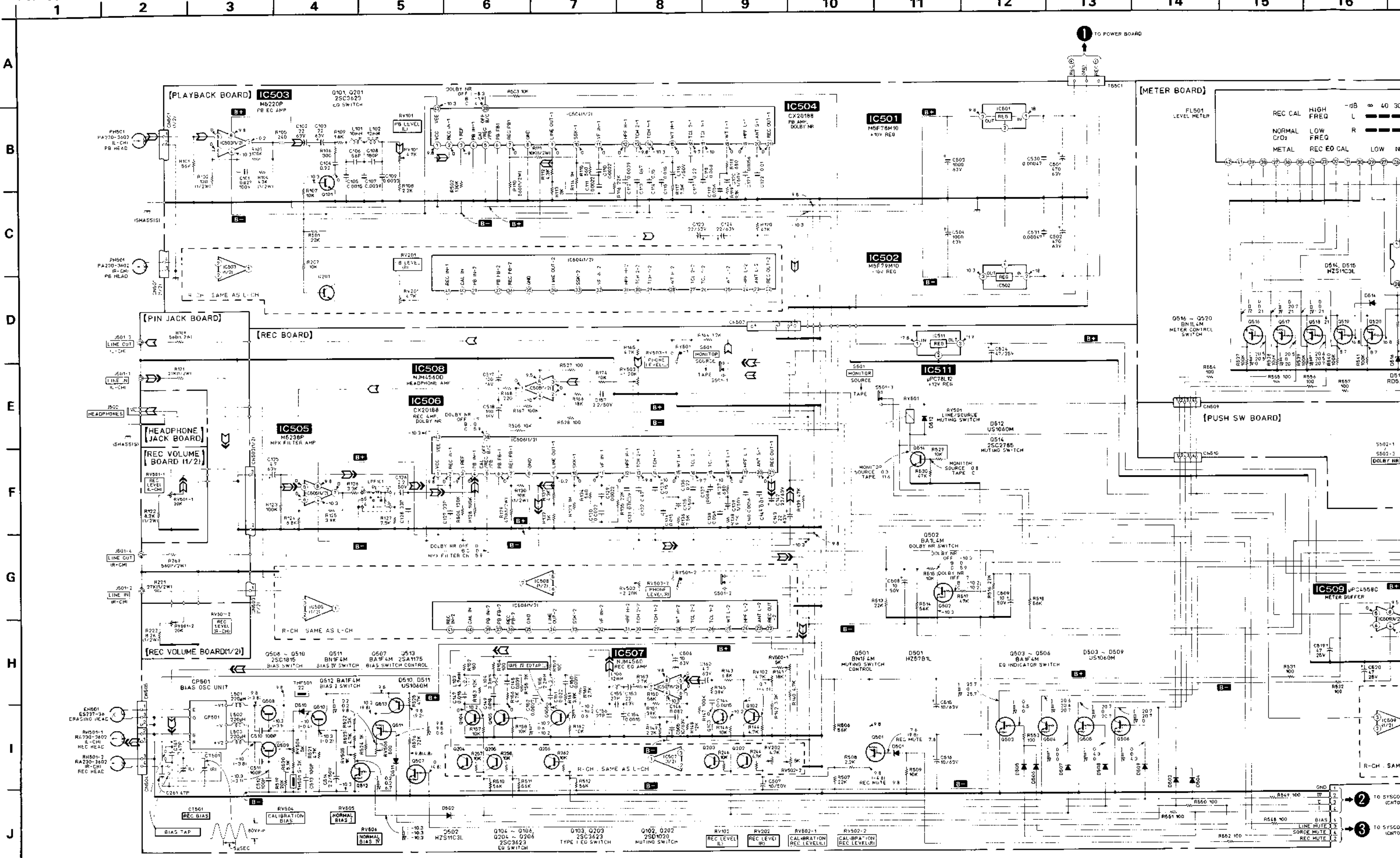

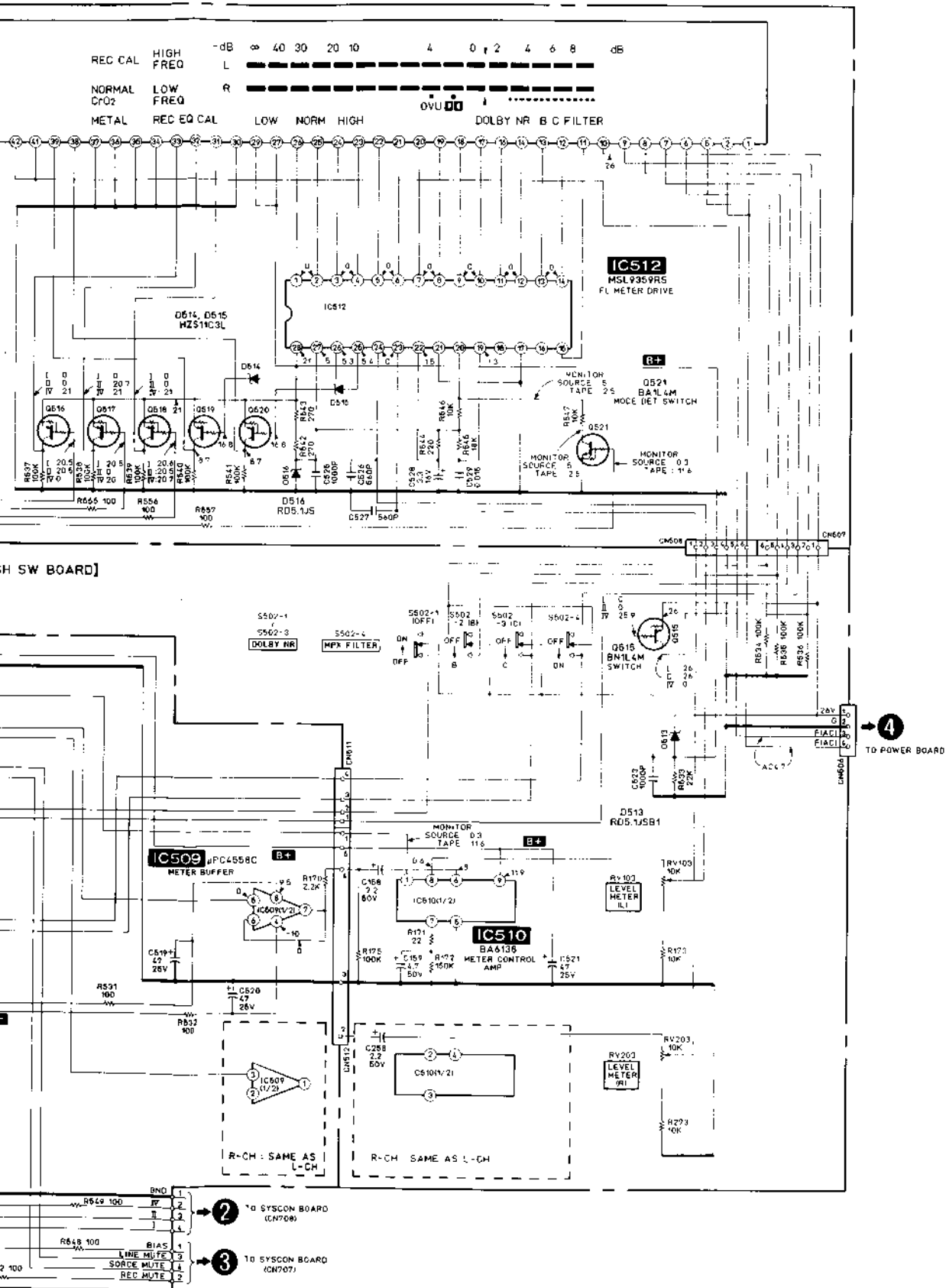

Note:

- All capacitors are in μF unless otherwise noted. pF: μμF. 50WV or less are not indicated except for electrolytics and tantalums.
- All resistors are in Ω and 1/4W or less unless otherwise specified.
- Components for right channel have same values as for left channel. Reference numbers are coded from 200.
- **B+** : B+ Line
- **B-** : B- Line
- : adjustment for repair.
- Voltage and waveforms are dc with respect to ground under no-signal conditions.
- no mark: STOP
- ( ): REC
- I : NORMAL
- II : C.O.
- III : METAL
- Voltages are taken with a VOM (Input Impedance 10MΩ). Voltage variations may be noted due to normal production tolerances.
- Signal path.
- ∩ : PB
- ∩∩ : REC

IC504 CX20188

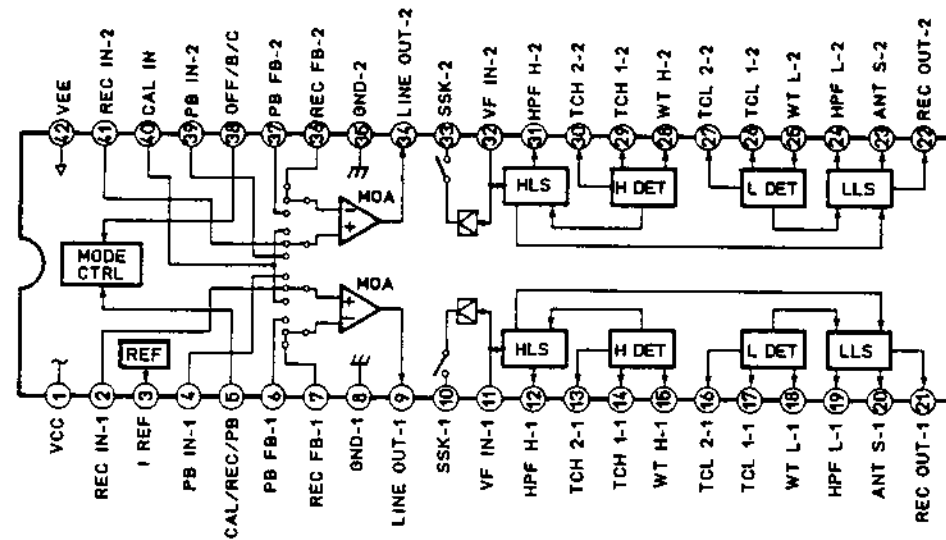

IC510 BA6138

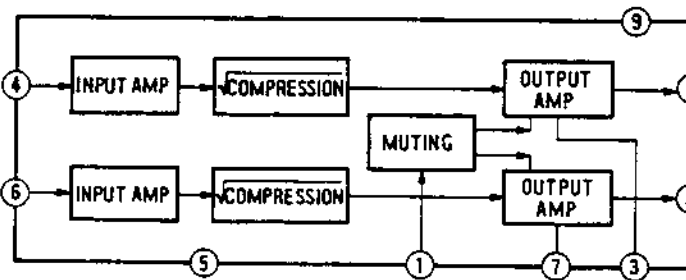

4-4. PRINTED WIRING BOARD—SYSTEM CONTROL SECTION—

• Refer to page 16 for Semiconductor Lead Layouts.

• Semiconductor Location

Ref. No.	Location	Ref. No.	Location
IC701	F-16	Q722	H-16
IC702	H-15	Q801	B-3
IC703	I-16		
IC704	I-17	D701	E-14
IC705	D-14	D702	G-13
IC706	F-23	D703	I-13
IC901	I-22	D704	G-14
IC902	J-23	D705	H-10
		D706	G-11
Q701	F-13	D707	G-12
Q702	G-13	D708	G-12
Q703	I-13	D709	C-20
Q704	G-13	D710	C-22
Q705	H-13	D711	B-22
Q706	F-13	D712	F-17
Q707	G-13	D713	E-23
Q708	I-12	D714	H-16
Q709	J-12	D801	D-3
Q710	G-13	D802	D-3
Q711	F-11	D803	D-4
Q712	F-11	D804	D-4
Q713	F-11	D805	D-5
Q714	F-11	D806	B-3
Q715	G-11	D807	D-1
Q716	G-11	D808	D-2
Q717	H-12	D809	E-2
Q718	I-12	D810	E-2
Q719	H-12	D1001	H-3
Q720	I-11	D1002	H-6
Q721	H-11		

Note:

- : parts extracted from the component side.
- : parts extracted from the conductor side.
- : parts mounted on the conductor side.

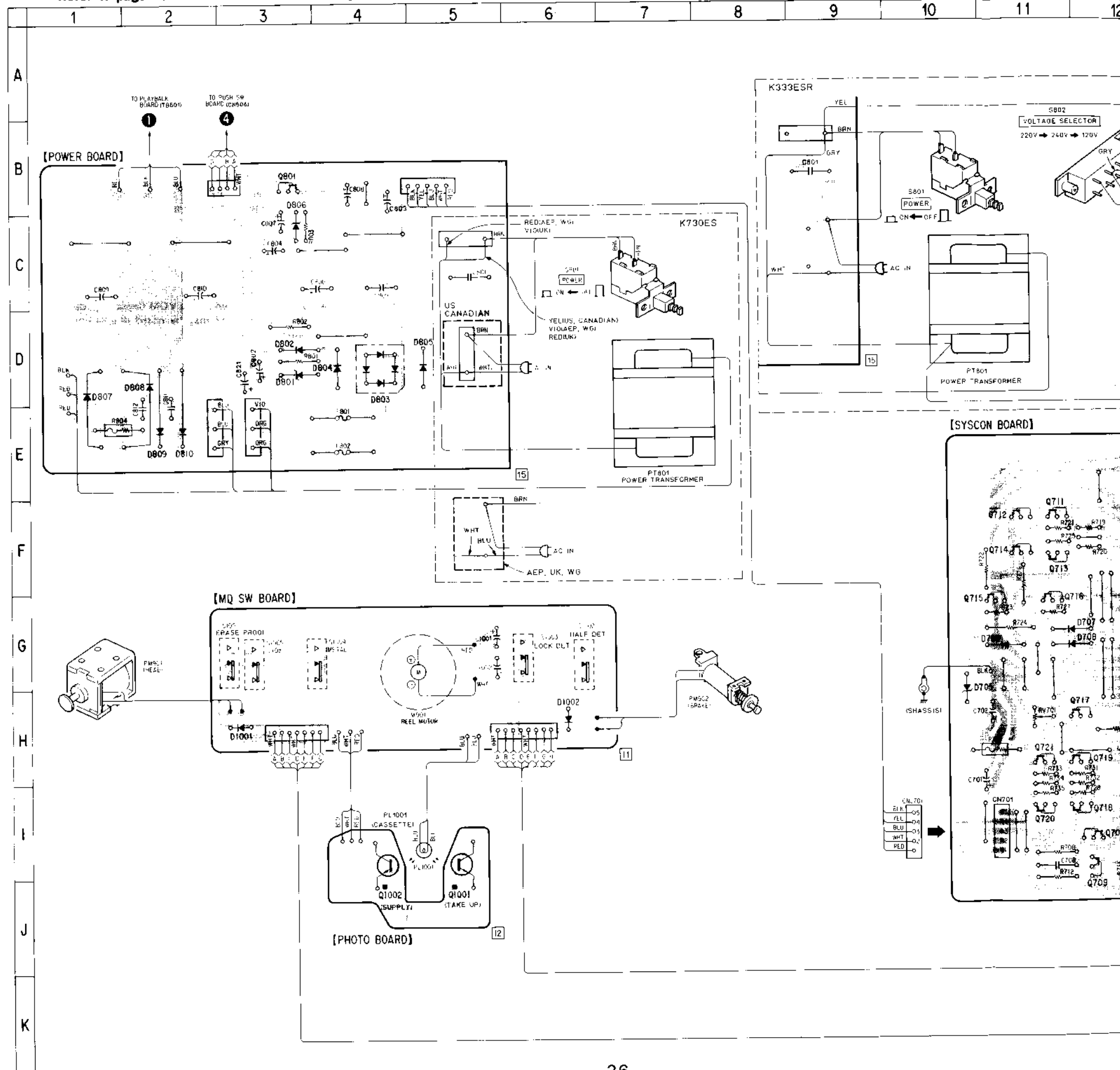

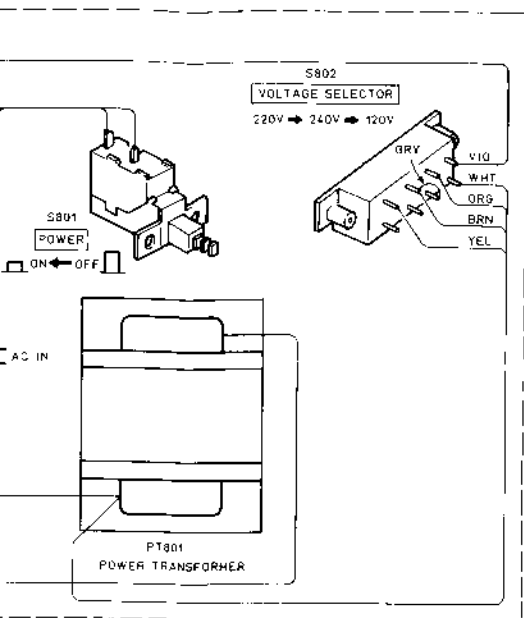

[REMOCON RECEIVER BOARD]

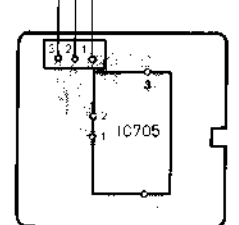

[TIMER SW BOARD]

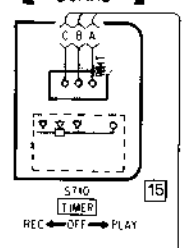

[CONTROL SW BOARD]

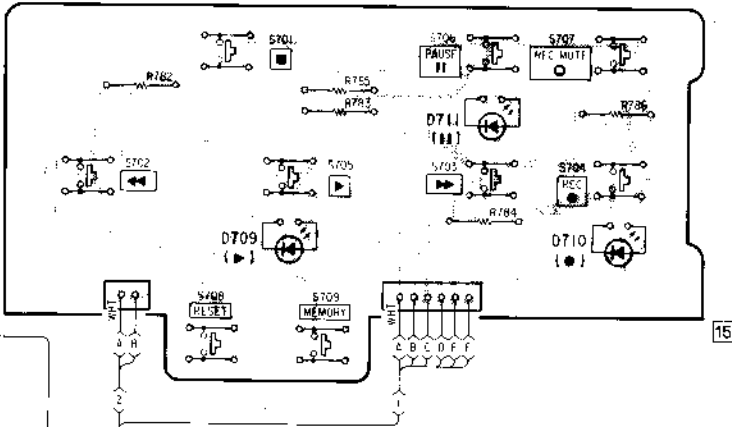

[SYSCON BOARD]

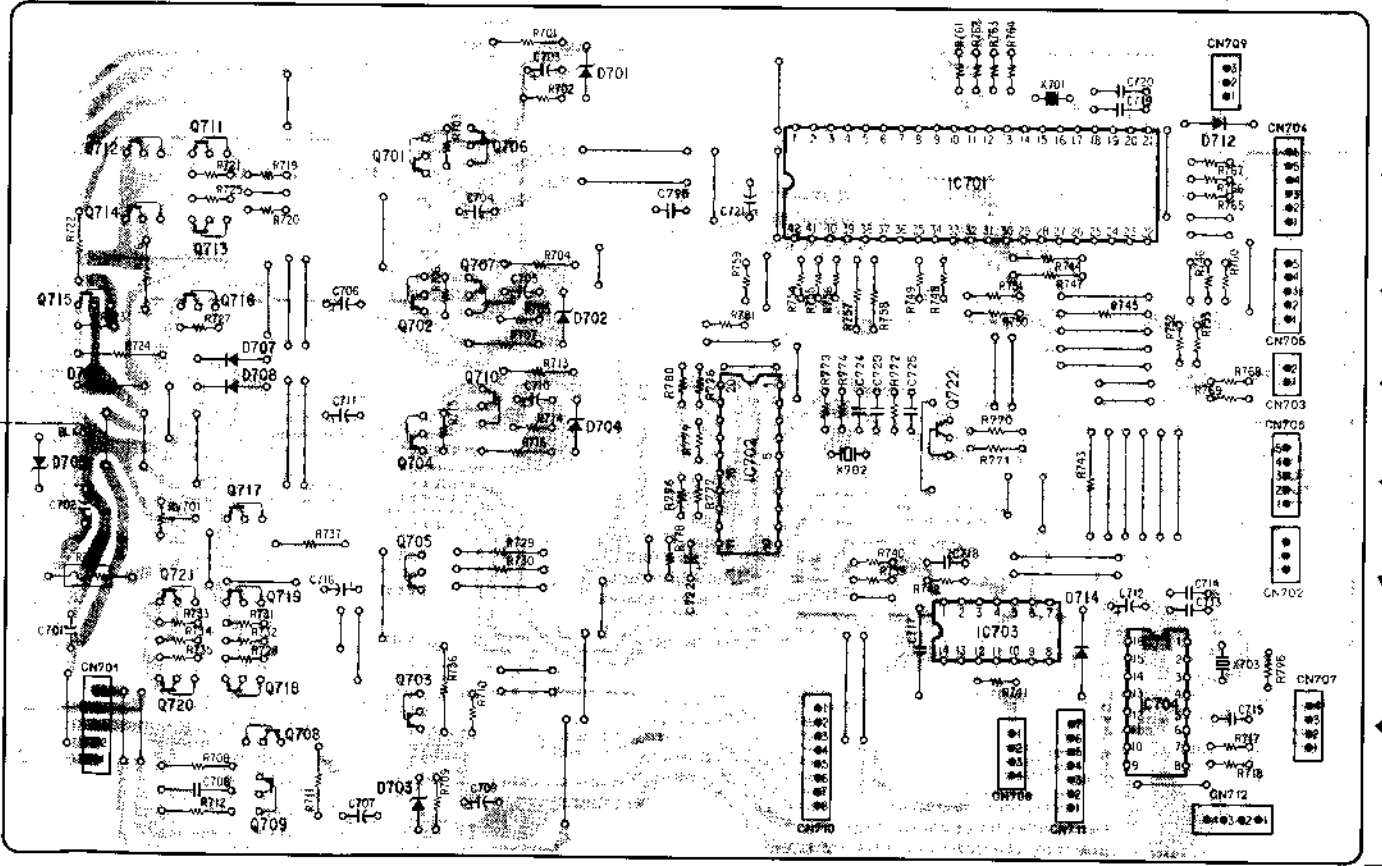

[COUNTER DISPLAY BOARD]

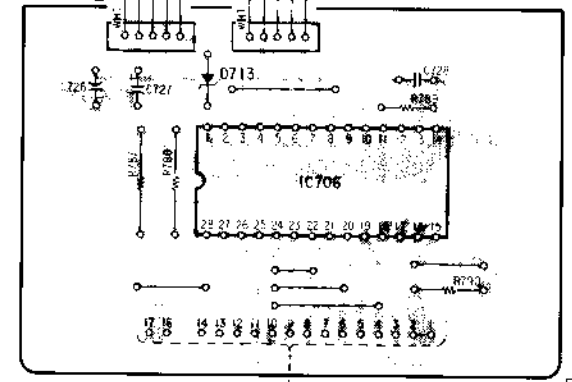

[CAPSTAN BOARD]

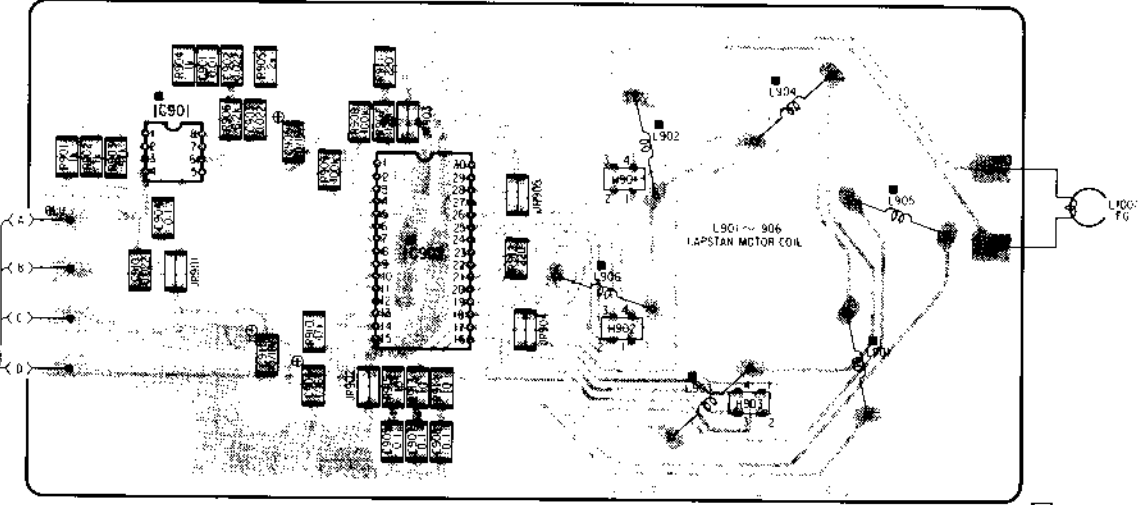

4-5. SCHEMATIC DIAGRAM—SYSTEM CONTROL SECTION—

1 2 3 4 5 6 7 8 9 10 11 12 13 14 15 16

A  
B  
C  
D  
E  
F  
G  
H  
I  
J

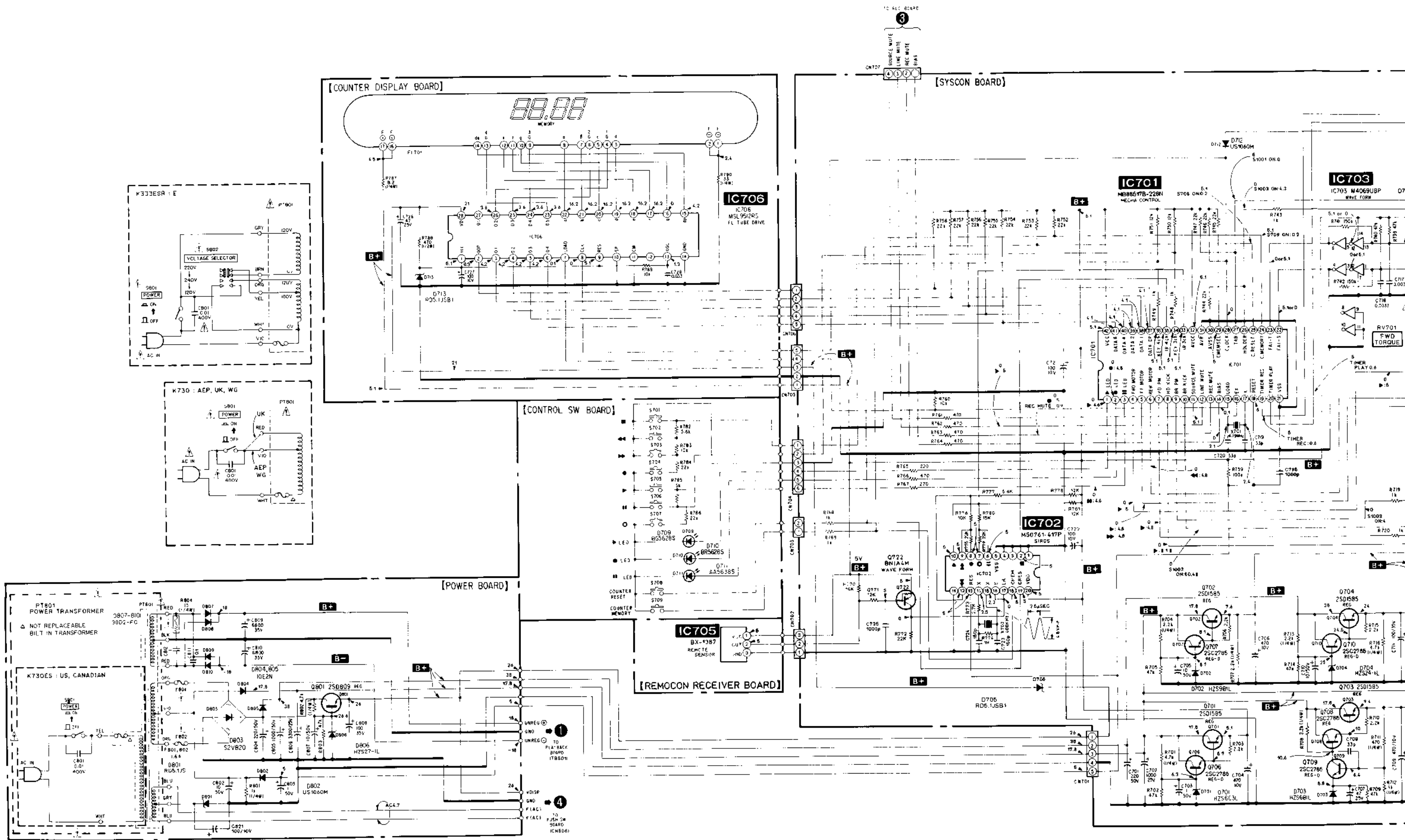

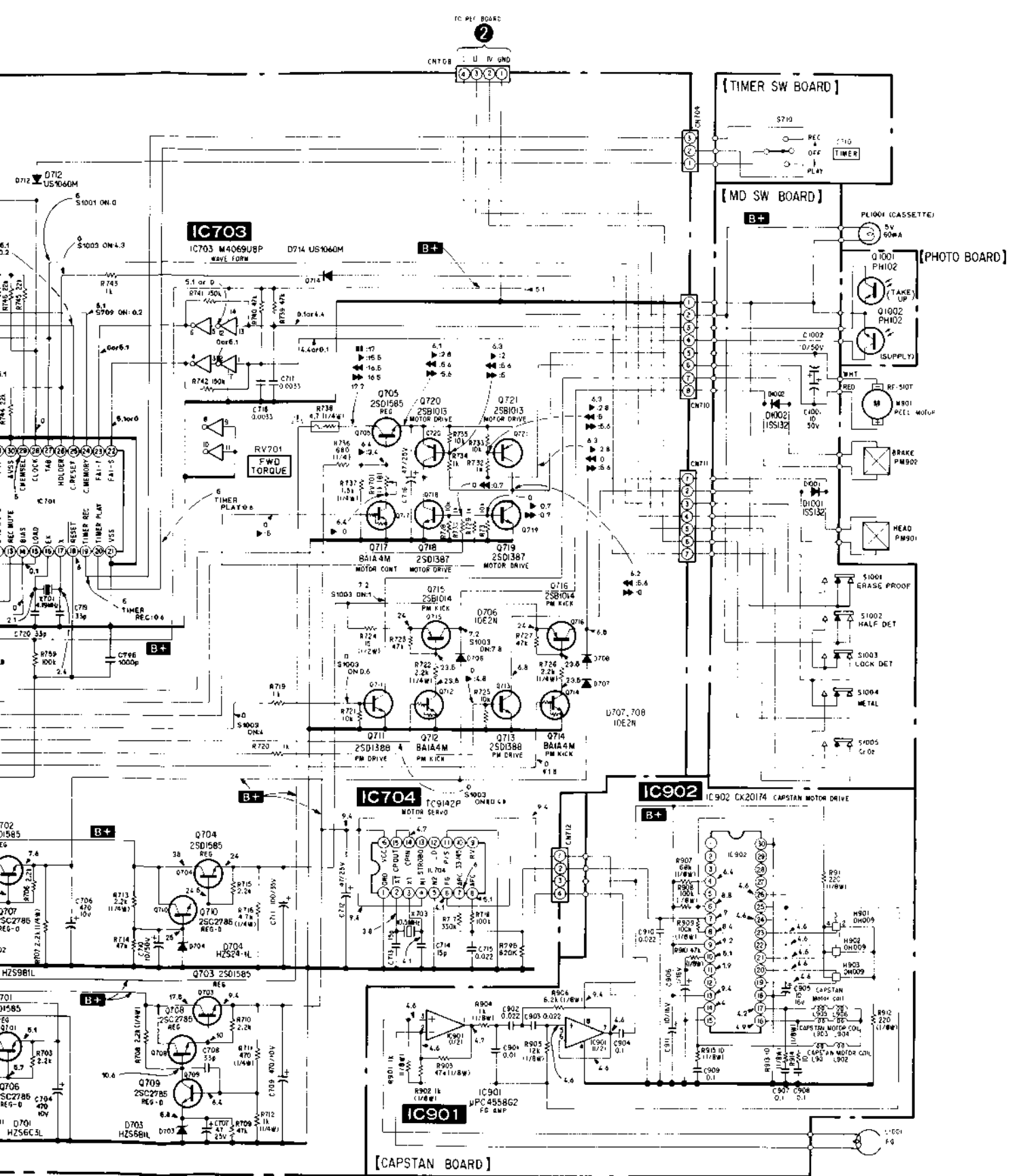

A  
B  
C  
D  
E  
F  
G  
H  
I  
J

- Note:**
- All capacitors are in  $\mu\text{F}$  unless otherwise noted.  $\text{pF} = \mu\mu\text{F}$ . 50WV or less are not indicated except for electrolytics and tantalums.
  - All resistors are in  $\Omega$  and  $\frac{1}{4}\text{W}$  or less unless otherwise specified.
  - : fusible resistor.
  - **B+** : B+ Line
  - **B-** : B- Line
  - : adjustment for repair.
  - Voltage and waveforms are dc with respect to ground under no-signal conditions.
  - no mark : STOP
  - (( )) : Momentary voltage in power switch ON.
  - ▶ : PLAY    || : PAUSE
  - ▶▶ : FF    ◀◀ : REW    ● : REC
  - Voltages are taken with a VOM (Input impedance 10M $\Omega$ ). Voltage variations may be noted due to normal production tolerances.

**Note:**  
The components identified by mark or dotted line with mark are critical for safety. Replace only with part number specified.

**Note:**  
Les composants identifiés par une marque sont critiques pour la sécurité. Ne les remplacer que par une pièce portant le numéro spécifié.

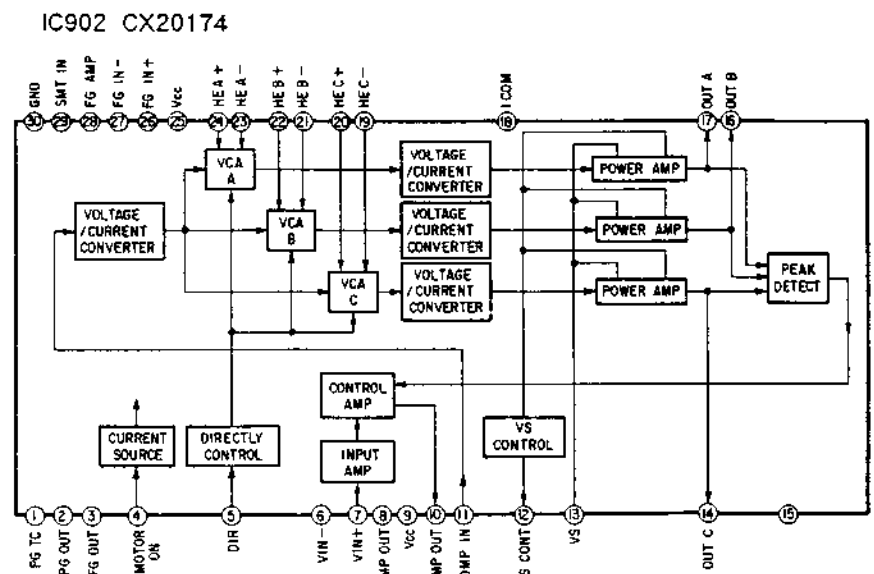

**SECTION 5  
EXPLODED VIEWS**

**NOTE:**

- The mechanical parts with no reference number in the exploded views are not supplied.
- The construction parts of an assembled part are indicated with a collation number in the remark column.
- Items marked "\*" are not stocked since they are seldom required for routine service. Some delay should be anticipated when ordering these items.

- Due to standardization, parts with part number suffix -XX and -X may be different from the parts specified in the components used on the set.
- Color Indication of Appearance Parts  
Example:  
(RED) ... KNOB, BALANCE (WHITE)  
↑ Cabinet's Color                      ↑ Parts Color

The components identified by mark or dotted line with mark are critical for safety. Replace only with part number specified.

Les composants identifiés par une marque sont critiques pour la sécurité. Ne les remplacer que par une pièce portant le numéro spécifié.

**5-1. CASE**

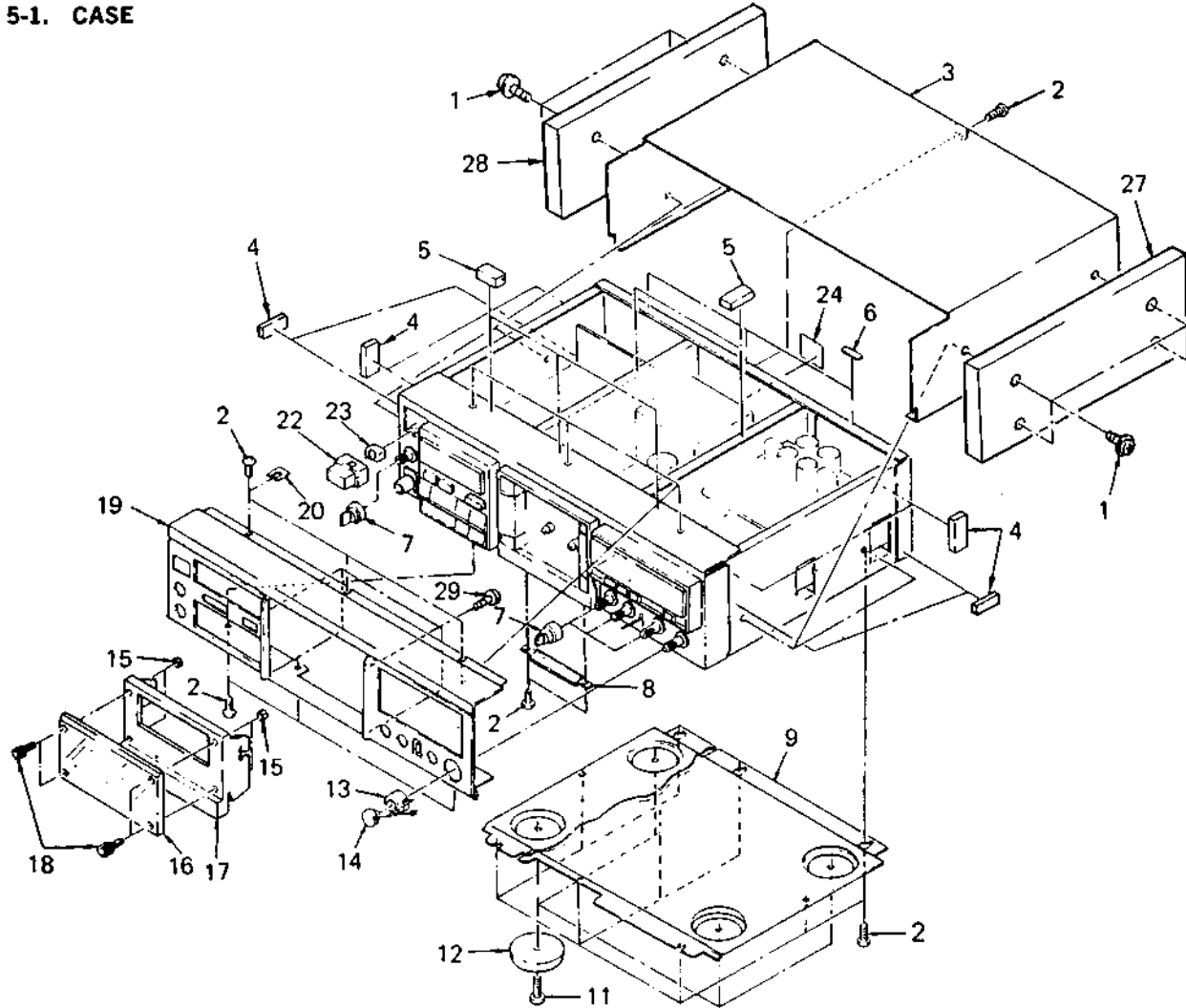

**5-2. FRONT PANEL**

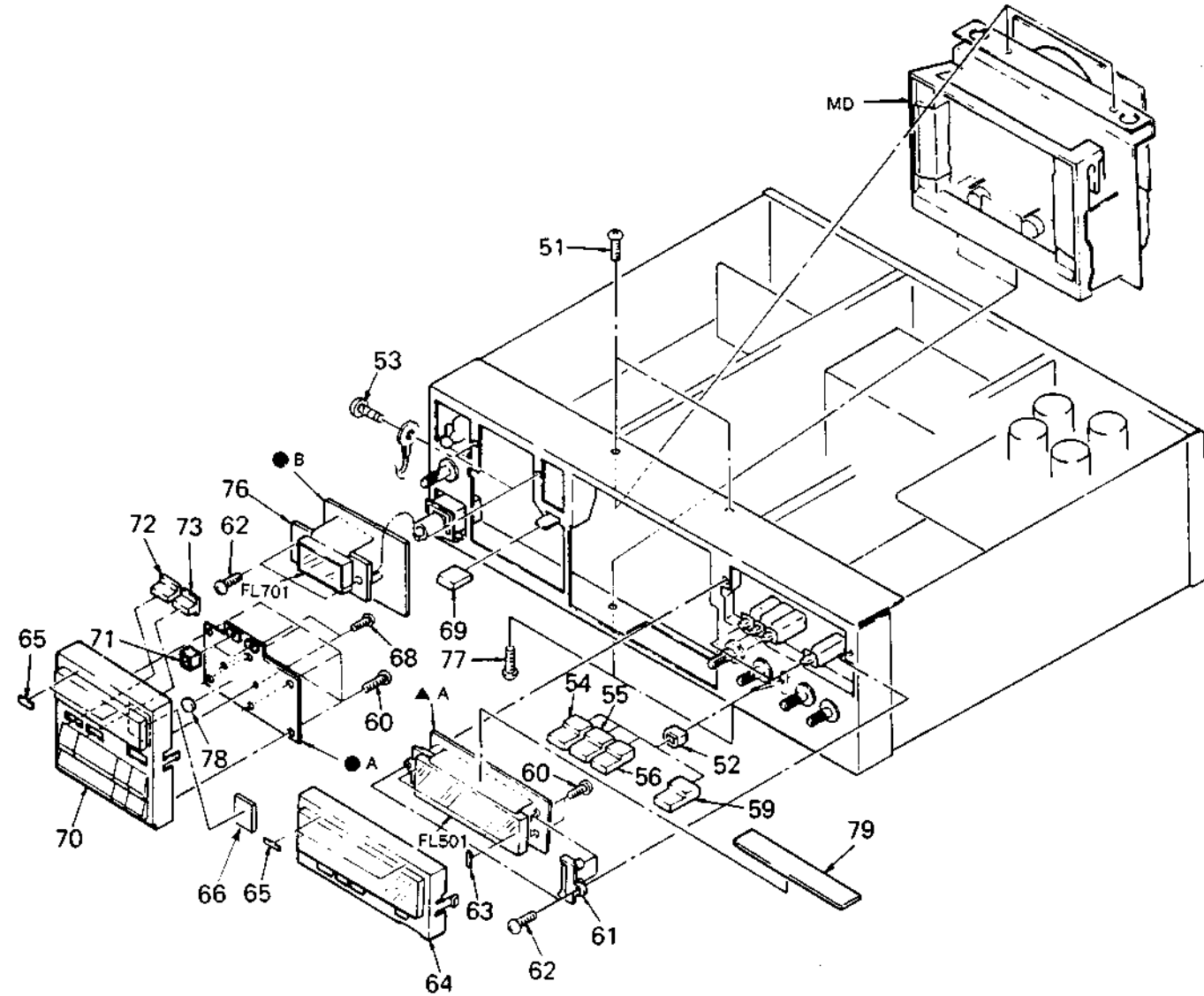

**5-3. CHASSIS**

**Note:**  
The components identified by mark or dotted line with mark are critical for safety. Replace only with part number specified.

9  
9

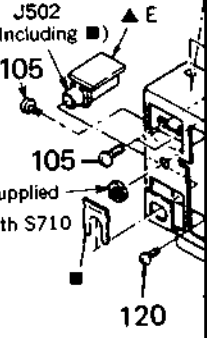

No.	Part No.	Description	Remarks	No.	Part No.	Description	Remarks
1	4-820-330-31 4-885-979-11	(UK)...SCREW, BW, PLUS MINUS (EXCEPT UK)...SCREW (4X25)		19	X-3304-946-1 X-3304-949-1 X-3304-951-1	(E)...PANEL ASSY, FRONT (US,Canadian)...PANEL ASSY, FRONT (AEP,UK)...PANEL ASSY, FRONT	
2	7-682-547-09	SCREW +BV 3X6, S TIGHT		20	3-544-028-21	SPACER	
3	3-318-660-11	CASE		22	4-908-046-01	KNOB, SQUARE	
4	9-911-841-XX	CUSHION		23	4-864-307-00	RING	
5	9-911-843-XX	CUSHION, FLYWHEEL		24	*3-350-430-01 *3-350-431-01 *3-350-432-01 *3-350-433-01	(E)...LABEL, MODEL NUMBER (US,Canadian)...LABEL, MODEL NUMBER (AEP)...LABEL, MODEL NUMBER (UK)...LABEL, MODEL NUMBER	
6	9-911-837-XX	CUSHION (B), FILTER		27	X-3304-936-1	(US,Canadian,AEP,E) ...PLATE (RIGHT) ASSY, SIDE	
7	3-304-929-11	KNOB, HEADPHONE		X-3304-948-1	(WG)...PLATE (RIGHT) ASSY, SIDE		
8	3-304-962-00	COVER, MD		28	X-3304-937-1	(US,Canadian,AEP,E) ...PLATE (LEFT) ASSY, SIDE	
9	*3-350-419-01	BOARD, BOTTOM		X-3304-947-1	(WG)...PLATE (LEFT) ASSY, SIDE		
10	3-703-685-21	SCREW (+BV 3X8)		29	7-685-104-19	SCREW +P 2X6 TYPE2 NON-SLIT	
11	7-682-562-09	SCREW +B 4X10					
12	X-3304-944-1	FOOT ASSY					
13	X-3304-924-1	KNOB (LEFT) ASSY, REC					
14	X-3304-925-1	KNOB (RIGHT) ASSY, REC					
15	7-622-207-05	N 2.6, TYPE 2					
16	3-350-410-01	WINDOW, CASSETTE					
17	3-350-415-11	L10, CASSETTE					
18	7-683-412-05	BOLT, HEXAGON SOCKET 2.6X6					

No.	Part No.	Description	Remarks	No.	Part No.	Description	Remarks
51	7-682-547-09	SCREW +BV 3X6, S TIGHT		66	*3-318-670-01	COVER, RAY CATCHER	
52	4-864-307-00	RING		68	7-621-772-50	SCREW +B 2X10	
53	7-685-870-09	SCREW +BVTT 3X5 (S)		69	3-318-643-01	BUTTON, EJECT	
54	3-318-652-41	PUSH BUTTON		70	X-3304-927-2 X-3304-950-1	(WG)...ESCUTCHEON ASSY, CONTROL BUTTON (US,Canadian,AEP,UK,E) ...ESCUTCHEON ASSY, CONTROL BUTTON	
55	3-318-652-51	PUSH BUTTON		71	*3-311-546-00	CUSHION, SWITCH, MONITOR	
56	3-318-652-61	PUSH BUTTON		72	3-311-506-01	BUTTON, COUNTER	
59	3-318-652-01	PUSH BUTTON		73	3-311-506-11	BUTTON, COUNTER	
60	7-685-133-19	SCREW +BTP 2.6X6 TYPE2 N-S		76	*3-318-651-01	BRACKET, COUNTER	
61	*3-318-632-01	BRACKET, METER		77	7-685-870-01	SCREW +BVTT 3X5 (S)	
62	7-685-861-09	SCREW +BVTT 2.6X5 (S)		78	*3-312-975-01	SPACER	
63	9-911-837-XX	CUSHION (B), FILTER		79	9-911-863-XX	SPACER	
64	X-3304-933-1	ESCUTCHEON ASSY, METER		FL501	1-519-497-11	INDICATOR TUBE, FLUORESCENT	
65	3-553-566-00	CUSHION		FL701	1-519-409-11	INDICATOR TUBE, FLUORESCENT (COUNTER)	

No.	Part No.	Description	Remarks
101	7-682-647-09		
102	*3-304-987-01		
103	4-886-821-01		
104	*3-318-658-11		
105	7-682-547-09		
106	4-916-783-01		
108	3-646-090-11		
109	*4-861-002-00		
110	3-703-685-21		
111	7-682-547-04		
113	7-685-870-01		
117	*4-363-146-00		
120	7-685-861-09		
121	3-575-524-00		
122	*3-318-628-01		
123	3-534-238-XX		
124	*3-575-502-00		
127	7-682-147-15		
128	*3-318-666-01		
129	4-870-539-00		
130	4-886-821-11		
131	7-685-646-79		
132	*3-701-947-13		
901	*A-2010-295-A		







No.	Part No.	Description	Remarks	No.	Part No.	Description	Remarks
201	3-575-449-00	LEVER, DETECTION, REC		242	3-537-213-00	SPRING, COMPRESSION	
202	3-575-331-00	LEVER, DETECTION, HALF		243	3-575-481-00	SPRING, TENSION	
203	*3-318-406-11	PLATE, ORNAMENTAL, HEAD		245	3-701-439-11	WASHER	
204	3-575-358-00	SPRING, TENSION		246	3-318-405-01	RETAINER, SPRING	
205	3-575-328-00	HOLDER, LAMP		247	3-571-850-11	SPRING, COMPRESSION	
206	7-671-112-11	BALL, STEEL		248	3-318-438-01	TABLE, REEL	
207	*3-575-378-00	GUIDE, LEAD		249	3-558-708-11	WASHER, STOPPER	
208	3-575-351-00	SPRING		250	3-576-921-00	SPRING, COMPRESSION	
210	3-701-439-21	WASHER		251	3-531-760-00	CLAW, REEL SPINDLE	
211	X-3575-380-1	PINCH LEVER (T) ASSY		252	3-558-339-00	CLAW (R), REEL TABLE	
212	7-624-105-04	STOP RING 2.3, TYPE -E		253	3-576-983-01	CAP, REEL	
213	X-3575-323-0	CHASSIS ASSY, HEAD		254	3-575-459-00	PISTON	
214	*3-304-963-00	RETAINER, LEAD		255	3-575-392-00	RING, PISTON	
215	3-564-121-00	SPRING, COMPRESSION		256	X-3575-310-0	LEVER ASSY, TENSION, BACK	
216	7-671-113-11	BALL, STEEL		257	3-307-381-00	SPRING, TENSION	
217	7-621-775-20	SCREW +B 2.6X5		258	*3-306-279-00	LEVER, ERASING PROTECTION	
218	*3-575-377-00	SPRING		259	*3-306-281-00	SHAFT, DETECTION LEVER	
219	3-575-348-00	ROLLER, GUIDE, THREADING		260	*3-306-282-00	LEVER, REC DETECTION, REVERSE	
220	3-575-355-31	HOLDER, CASSETTE		261	3-318-408-01	SPRING	
221	3-555-114-00	SPRING (LEFT)		262	9-911-815-02	CUSHION	
222	X-3575-399-1	PLATE ASSY, ORNAMENTAL		264	3-575-438-00	LEVER, DETECTION	
223	3-555-113-00	SPRING (RIGHT)		265	3-575-446-00	LEVER, DETECTION, METAL	
224	*X-3575-339-0	PLATE (RIGHT) ASSY, FULCRUM		266	*3-575-440-00	BRACKET, LEVER, DETECTION	
225	7-621-770-87	SCREW +PTT 2.6X5 (S)		267	3-318-433-01	SPRING	
226	7-621-772-10	SCREW +B 2X4		268	3-575-346-01	FELT, BREKE	
227	3-304-639-00	PLATE, SHIELD, HEAD		269	7-624-104-04	STOP RING 2.0, TYPE -E	
228	3-306-215-00	LEVER, FULCRUM, HOLDER		270	7-685-870-01	SCREW +BVTT 3X5 (S)	
229	3-575-356-00	SPRING		271	*X-3575-364-0	BRACKET ASSY, LEVER	
230	3-575-364-00	SPRING, TENSION		272	3-575-448-00	LEVER, LOCK	
231	*X-3575-338-0	PLATE (LEFT) ASSY, FULCRUM		951	*1-608-268-00	PC BOARD, ERASE HEAD	
232	7-621-771-06	SCREW, LOCK		953	*1-603-823-00	PC BOARD, PHOTO	
233	7-621-772-88	SCREW +B 2X16		EH501	1-543-358-11	HEAD, MAGNETIC (ERASE)	
234	7-621-772-20	SCREW +B 2X5		PH501	8-825-770-51	HEAD, REC/PB RPA230-3602C (including RH501)	
235	7-622-205-05	NUT M2 TYPE2		PL1001	1-518-313-00	LAMP, PILOT	
236	*3-306-216-00	BRACKET, HEAD, ERASE					
237	3-564-138-00	GUIDE (S), TAPE					
238	7-684-023-04	N 3, TYPE 2					
239	3-491-191-00	COLLAR					
241	X-3575-321-0	PINCH LEVER (S) ASSY					

5-5. MECHANISM SECTION (2)  
(TCM-110D3)

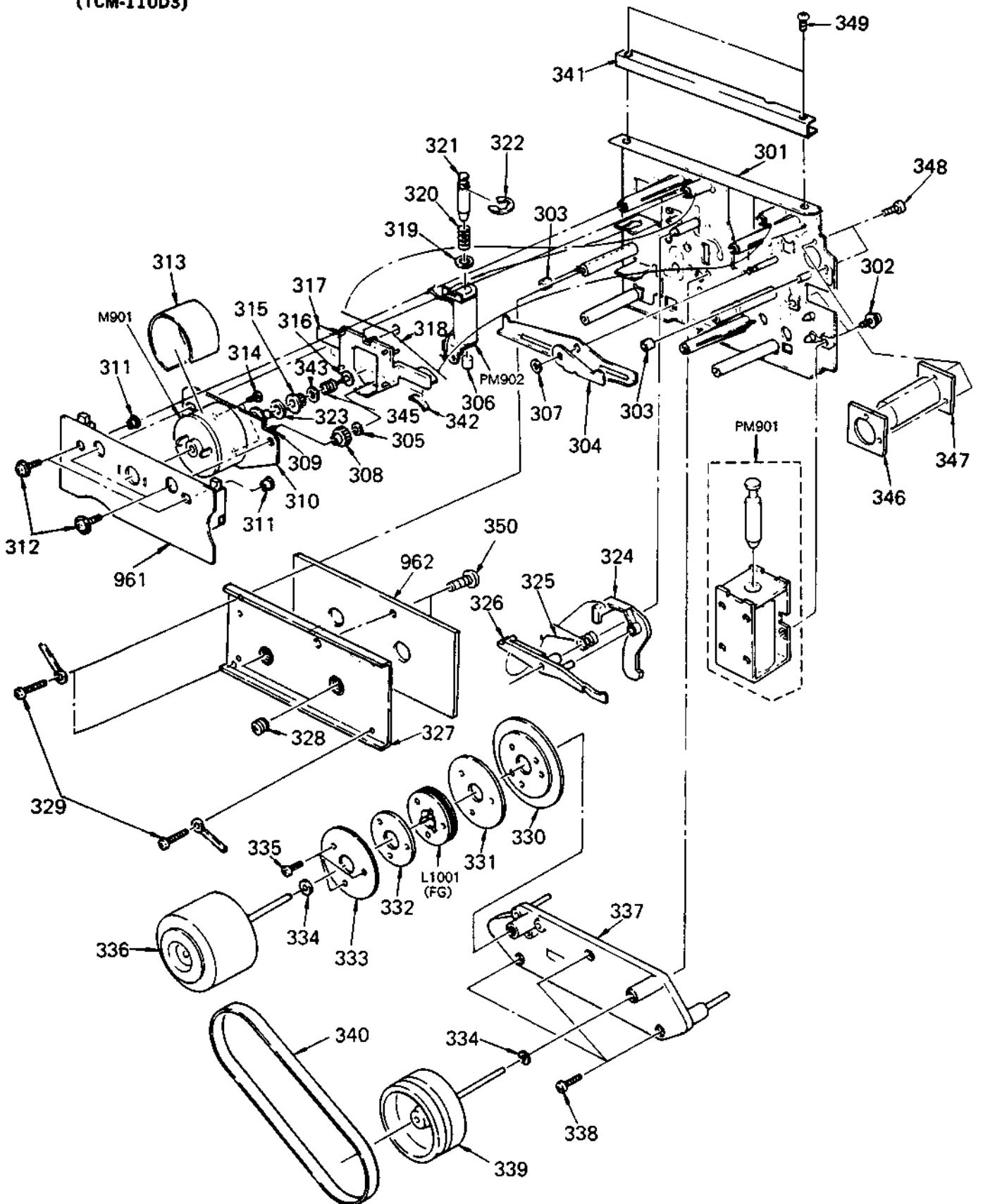

No.	Part No.	Description	Remarks	No.	Part No.	Description	Remarks
301	*X-3306-201-1	CHASSIS ASSY, MECHANICAL		328	3-489-073-00	SCREW, THRUST	
302	7-682-649-09	SCREW +PSW 3X10		329	7-682-647-09	SCREW +PS 3X6	
304	*3-306-260-00	LEVER, FWD		330	*3-310-831-01	PLATE, SHIELD, MOTOR	
305	3-558-708-01	WASHER, STOPPER		331	*3-576-810-00	PLATE, RETURN CIRCUIT	
306	3-575-416-11	ARBOR, FIXED		332	3-310-865-00	WASHER, INSULATING	
307	3-558-708-11	WASHER, STOPPER		333	3-576-961-11	PLATE, FG	
308	3-575-332-00	GEAR, FR		334	3-701-438-21	WASHER	
309	3-575-304-00	SHAFT, GEAR, FR		335	7-621-775-60	SCREW +B 2.6X12	
311	3-306-277-00	LIFTER, PC BOARD		336	X-3575-377-1	FLYWHEEL (TAKE-UP) ASSY	
312	7-685-646-79	SCREW, TOTSU PTPWH 3X8, TYPE2		337	X-3575-383-1	BASE ASSY, CAPSTAN	
313	3-306-209-00	PLATE (D), SHIELD, MOTOR		338	7-621-770-87	SCREW +PTT 2.6X5 (S)	
314	7-621-775-10	SCREW +B 2.6X4		339	X-3575-378-1	FLYWHEEL (SUPPLY) ASSY	
315	3-575-324-00	GEAR, LIMITER		340	3-576-812-00	BELT, CAPSTAN	
316	3-575-327-00	STOPPER		341	*3-318-437-01	BRACKET, MD	
317	*X-3575-342-0	PLATE ASSY, BRAKE		342	3-575-469-00	SHOE, BRAKE	
318	3-575-345-00	SPRING		343	3-701-441-11	WASHER	
319	3-701-444-11	WASHER, 6		344	3-701-748-00	CLAMP	
320	3-575-414-00	SPRING, COMPRESSION		345	3-575-487-01	SPRING, COMPRESSION	
321	3-575-415-11	ARBOR, MOVABLE		346	*3-318-439-01	BRACKET	
322	7-624-109-04	STOP RING 5.0, TYPE -E		347	*3-318-440-01	CYLINDER	
323	3-564-027-11	FELT, LIMITER		961	*1-620-542-11	PC BOARD, MD SWITCH	
324	3-575-318-00	LEVER, LOCK, TUNING		962	*1-620-086-11	PC BOARD, CAPSTAN	
325	3-575-458-00	SPRING		M901	X-3575-382-1	MOTOR ASSY, REEL	
326	3-575-460-00	LEVER, SELECT TUNE		PM901	1-454-333-00	SOLENOID, PLUNGER	
327	X-3306-202-1	RETAINER ASSY, THRUST		PM902	1-454-291-00	SOLENOID, PLUNGER	

## SECTION 6 ELECTRICAL PARTS LIST

**NOTE:**

- Due to standardization, replacements in the parts list may be different from the parts specified in the diagrams or the components used on the set.
- Items marked "\*" are not stocked since they are seldom required for routine service. Some delay should be anticipated when ordering these items.
- If there are two or more same circuits in a set such as a stereophonic machine, only typical circuit parts may be indicated and capacitors and resistors in other same circuits may be omitted.

**CAPACITORS:**

MF:  $\mu$ F, PF:  $\mu$ PF.

**RESISTORS**

- All resistors are in ohms.
- F: nonflammable

**COILS**

- MMH: mH, UH:  $\mu$ H

**SEMICONDUCTORS**

In each case, U:  $\mu$ , for example:  
 UA...:  $\mu$ A..., UPA...:  $\mu$ PA...,  
 UPC...:  $\mu$ PC, UPD...:  $\mu$ PD...

The components identified by mark  $\Delta$  or dotted line with mark  $\Delta$  are critical for safety. Replace only with part number specified.

Les composants identifiés par une marque  $\Delta$  sont critiques pour la sécurité. Ne les remplacer que par une pièce portant le numéro spécifié.



Ref.No.	Part No.	Description					Ref.No.	Part No.	Description				
901	*A-2010-295-A	PC BOARD ASSY, AUDIO					C128	1-162-211-31	CERAMIC	33PF	5%	50V	
902	*A-2056-449-A	{US,Canadian,E} ...PC BOARD ASSY, SYSTEM CONTROL					C129	1-130-475-00	MYLAR	0.0022MF	5%	50V	
	*A-2056-450-A	{AEP,UK}...PC BOARD ASSY, SYSTEM CONTROL					C130	1-130-475-00	MYLAR	0.0022MF	5%	50V	
903	$\Delta$ 1-555-795-11	{AEP}.....CODE, POWER					C131	1-130-478-00	MYLAR	0.0039MF	5%	50V	
	$\Delta$ 1-556-035-00	{UK}.....CODE, POWER					C132	1-136-173-00	FILM	0.47MF	5%	50V	
	$\Delta$ 1-559-297-21	{E}.....CODE, POWER					C133	1-136-167-00	FILM	0.15MF	5%	50V	
	$\Delta$ 1-559-479-11	{US,Canadian}...CODE, POWER					C134	1-136-155-00	FILM	0.015MF	5%	50V	
904	$\Delta$ 1-533-162-00	HOLDER, FUSE					C135	1-123-380-00	ELECT	1MF	20%	50V	
905	*1-535-116-00	TERMINAL					C136	1-136-169-00	FILM	0.22MF	5%	50V	
906	*1-535-139-00	BASE POST 22MM (10MM PITCH) 2P					C137	1-136-163-00	FILM	0.068MF	5%	50V	
907	*1-620-540-11	PC BOARD, SYSTEM CONTROL					C138	1-136-162-00	FILM	0.056MF	5%	50V	
908	$\Delta$ 1-526-565-00	{E}...AC PLUG ADAPTOR					C139	1-123-380-00	ELECT	1MF	20%	50V	
909	1-535-416-01	{AEP,UK}...TERMINAL					C140	1-130-480-00	MYLAR	0.0056MF	5%	50V	
951	*1-608-268-00	PC BOARD, ERASE HEAD					C141	1-136-153-00	FILM	0.01MF	5%	50V	
953	*1-603-823-00	PC BOARD, PHOTO					C142	1-124-929-11	ELECT	22MF	20%	63V	
961	*1-620-542-11	PC BOARD, MD SWITCH					C143	1-124-929-11	ELECT	22MF	20%	63V	
962	*1-620-086-11	PC BOARD, CAPSTAN					C144	1-130-473-00	MYLAR	0.0015MF	5%	50V	
C101	1-130-893-00	FILM	0.027MF	3%	100V	C145	1-136-164-00	FILM	0.082MF	5%	50V		
C102	1-124-929-11	ELECT	22MF	20%	63V	C146	1-136-155-00	FILM	0.015MF	5%	50V		
C103	1-124-929-11	ELECT	22MF	20%	63V	C147	1-136-160-00	FILM	0.039MF	5%	50V		
C104	1-136-169-00	FILM	0.22MF	5%	50V	C148	1-136-160-00	FILM	0.039MF	5%	50V		
C105	1-130-473-00	MYLAR	0.0015MF	5%	50V	C149	1-136-156-00	FILM	0.018MF	5%	50V		
C106	1-107-165-00	MICA	56PF	5%	500V	C150	1-136-160-00	FILM	0.039MF	5%	50V		
C107	1-130-478-00	MYLAR	0.0039MF	5%	50V	C151	1-136-157-00	FILM	0.022MF	5%	50V		
C108	1-109-619-00	MICA	180PF	5%	500V	C152	1-130-476-00	MYLAR	0.0027MF	5%	50V		
C109	1-130-477-00	MYLAR	0.0033MF	5%	50V	C153	1-124-929-11	ELECT	22MF	20%	63V		
C110	1-130-475-00	MYLAR	0.0022MF	5%	50V	C154	1-130-473-00	MYLAR	0.0015MF	5%	50V		
C111	1-130-475-00	MYLAR	0.0022MF	5%	50V	C155	1-107-157-00	MICA	27PF	5%	500V		
C112	1-130-478-00	MYLAR	0.0039MF	5%	50V	C156	1-107-157-00	MICA	27PF	5%	500V		
C113	1-136-173-00	FILM	0.47MF	5%	50V	C157	1-124-767-00	ELECT	2.2MF	20%	50V		
C114	1-136-167-00	FILM	0.15MF	5%	50V	C158	1-124-925-11	ELECT	2.2MF	20%	50V		
C115	1-136-155-00	FILM	0.015MF	5%	50V	C159	1-124-927-11	ELECT	4.7MF	20%	50V		
C116	1-123-380-00	ELECT	1MF	20%	50V	C160	1-123-369-00	ELECT	4.7MF	20%	63V		
C117	1-136-169-00	FILM	0.22MF	5%	50V	C161	1-107-163-00	MICA	47PF	5%	500V		
C118	1-136-163-00	FILM	0.068MF	5%	50V	C201	1-130-893-00	FILM	0.027MF	3%	100V		
C119	1-136-162-00	FILM	0.056MF	5%	50V	C202	1-124-929-11	ELECT	22MF	20%	63V		
C120	1-123-380-00	ELECT	1MF	20%	50V	C203	1-124-929-11	ELECT	22MF	20%	63V		
C121	1-130-480-00	MYLAR	0.0056MF	5%	50V	C204	1-136-169-00	FILM	0.22MF	5%	50V		
C122	1-136-153-00	FILM	0.01MF	5%	50V	C205	1-130-473-00	MYLAR	0.0015MF	5%	50V		
C123	1-124-929-11	ELECT	22MF	20%	63V	C206	1-107-165-00	MICA	56PF	5%	500V		
C124	1-124-929-11	ELECT	22MF	20%	63V	C207	1-130-478-00	MYLAR	0.0039MF	5%	50V		
C125	1-123-369-00	ELECT	4.7MF	20%	63V	C208	1-109-619-00	MICA	180PF	5%	500V		
C126	1-124-767-00	ELECT	2.2MF	20%	50V	C209	1-130-477-00	MYLAR	0.0033MF	5%	50V		
C127	1-107-159-00	MICA	33PF	5%	500V	C210	1-130-475-00	MYLAR	0.0022MF	5%	50V		
							C211	1-130-475-00	MYLAR	0.0022MF	5%	50V	
							C212	1-130-478-00	MYLAR	0.0039MF	5%	50V	

Ref.No.	Part No.	Description				Ref.No.	Part No.	Description			
C213	1-136-173-00	FILM	0.47MF	5%	50V	C510	1-162-282-31	CERAMIC	100PF	10%	50V
C214	1-136-167-00	FILM	0.15MF	5%	50V	C511	1-162-282-31	CERAMIC	100PF	10%	50V
C215	1-136-155-00	FILM	0.015MF	5%	50V	C512	1-162-282-31	CERAMIC	100PF	10%	50V
C216	1-123-380-00	ELECT	1MF	20%	50V	C513	1-162-282-31	CERAMIC	100PF	10%	50V
C217	1-136-169-00	FILM	0.22MF	5%	50V	C514	1-124-925-11	ELECT	2.2MF	20%	50V
C218	1-136-163-00	FILM	0.068MF	5%	50V	C515	1-124-915-11	ELECT	10MF	20%	63V
C219	1-136-162-00	FILM	0.056MF	5%	50V	C516	1-124-915-11	ELECT	10MF	20%	63V
C220	1-123-380-00	ELECT	1MF	20%	50V	C517	1-123-333-00	ELECT	100MF	20%	16V
C221	1-130-480-00	MYLAR	0.0056MF	5%	50V	C518	1-123-333-00	ELECT	100MF	20%	16V
C222	1-136-153-00	FILM	0.01MF	5%	50V	C519	1-123-332-00	ELECT	47MF	20%	25V
C223	1-124-929-11	ELECT	22MF	20%	63V	C520	1-123-332-00	ELECT	47MF	20%	25V
C224	1-124-929-11	ELECT	22MF	20%	63V	C521	1-124-477-11	ELECT	47MF	20%	25V
C225	1-123-369-00	ELECT	4.7MF	20%	63V	C523	1-162-294-31	CERAMIC	0.001MF	10%	50V
C226	1-124-767-00	ELECT	2.2MF	20%	50V	C524	1-124-477-11	ELECT	47MF	20%	25V
C227	1-107-159-00	MICA	33PF	5%	500V	C525	1-162-294-31	CERAMIC	0.001MF	10%	50V
C228	1-162-211-31	CERAMIC	33PF	5%	50V	C526	1-162-291-31	CERAMIC	560PF	10%	50V
C229	1-130-475-00	MYLAR	0.0022MF	5%	50V	C527	1-162-291-31	CERAMIC	560PF	10%	50V
C230	1-130-475-00	MYLAR	0.0022MF	5%	50V	C528	1-131-368-00	TANTALUM	3.3MF	20%	16V
C231	1-130-478-00	MYLAR	0.0039MF	5%	50V	C529	1-136-802-11	FILM	0.015MF	5%	100V
C232	1-136-173-00	FILM	0.47MF	5%	50V	C530	1-130-467-00	MYLAR	470PF	5%	50V
C233	1-136-167-00	FILM	0.15MF	5%	50V	C531	1-130-467-00	MYLAR	470PF	5%	50V
C234	1-136-155-00	FILM	0.015MF	5%	50V	C701	1-124-911-11	ELECT	220MF	20%	50V
C235	1-123-380-00	ELECT	1MF	20%	50V	C702	1-124-557-11	ELECT	1000MF	20%	25V
C236	1-136-169-00	FILM	0.22MF	5%	50V	C703	1-124-499-11	ELECT	1MF	20%	50V
C237	1-136-163-00	FILM	0.068MF	5%	50V	C704	1-124-472-11	ELECT	470MF	20%	10V
C238	1-136-162-00	FILM	0.056MF	5%	50V	C705	1-123-875-11	ELECT	10MF	20%	50V
C239	1-123-380-00	ELECT	1MF	20%	50V	C706	1-124-472-11	ELECT	470MF	20%	10V
C240	1-130-480-00	MYLAR	0.0056MF	5%	50V	C707	1-124-477-11	ELECT	47MF	20%	25V
C241	1-136-153-00	FILM	0.01MF	5%	50V	C708	1-162-211-31	CERAMIC	33PF	5%	50V
C242	1-124-929-11	ELECT	22MF	20%	63V	C709	1-124-472-11	ELECT	470MF	20%	10V
C243	1-124-929-11	ELECT	22MF	20%	63V	C710	1-123-875-11	ELECT	10MF	20%	50V
C244	1-130-473-00	MYLAR	0.0015MF	5%	50V	C711	1-124-122-11	ELECT	100MF	20%	35V
C246	1-136-164-00	FILM	0.082MF	5%	50V	C712	1-124-477-11	ELECT	47MF	20%	25V
C247	1-136-155-00	FILM	0.015MF	5%	50V	C713	1-162-203-31	CERAMIC	15PF	5%	50V
C248	1-136-160-00	FILM	0.039MF	5%	50V	C714	1-162-203-31	CERAMIC	15PF	5%	50V
C249	1-136-156-00	FILM	0.018MF	5%	50V	C715	1-136-157-00	FILM	0.022MF	5%	50V
C250	1-136-160-00	FILM	0.039MF	5%	50V	C716	1-124-477-11	ELECT	47MF	20%	25V
C251	1-136-157-00	FILM	0.022MF	5%	50V	C717	1-161-327-00	CERAMIC	0.0033MF	20%	16V
C252	1-130-476-00	MYLAR	0.0027MF	5%	50V	C718	1-161-327-00	CERAMIC	0.0033MF	20%	16V
C253	1-124-929-11	ELECT	22MF	20%	63V	C719	1-162-211-31	CERAMIC	33PF	5%	50V
C254	1-130-473-00	MYLAR	0.0015MF	5%	50V	C720	1-162-211-31	CERAMIC	33PF	5%	50V
C255	1-107-157-00	MICA	27PF	5%	500V	C721	1-124-443-00	ELECT	100MF	20%	10V
C256	1-107-157-00	MICA	27PF	5%	500V	C722	1-124-443-00	ELECT	100MF	20%	10V
C257	1-124-767-00	ELECT	2.2MF	20%	50V	C723	1-162-284-31	CERAMIC	150PF	10%	50V
C258	1-124-925-11	ELECT	2.2MF	20%	50V	C724	1-162-284-31	CERAMIC	150PF	10%	50V
C259	1-124-927-11	ELECT	4.7MF	20%	50V	C725	1-162-294-31	CERAMIC	0.001MF	10%	50V
C260	1-123-369-00	ELECT	4.7MF	20%	63V	C726	1-124-477-11	ELECT	47MF	20%	25V
C261	1-107-163-00	MICA	47PF	5%	500V	C727	1-124-443-00	ELECT	100MF	20%	10V
C501	1-123-377-00	ELECT	470MF	20%	63V	C728	1-136-159-00	FILM	0.033MF	5%	50V
C502	1-123-377-00	ELECT	470MF	20%	63V	C795	1-162-294-31	CERAMIC	0.001MF	10%	50V
C503	1-123-378-00	ELECT	1000MF	20%	63V	C801	1-161-744-00	CERAMIC	0.01MF		400V
C504	1-123-378-00	ELECT	1000MF	20%	63V	C802	1-123-875-11	ELECT	10MF	20%	50V
C505	1-124-915-11	ELECT	10MF	20%	63V	C803	1-124-499-11	ELECT	1MF	20%	50V
C506	1-124-915-11	ELECT	10MF	20%	63V	C804	1-124-911-11	ELECT	220MF	20%	50V
C507	1-123-875-11	ELECT	10MF	20%	50V	C805	1-124-637-11	ELECT	1000MF	20%	50V
C508	1-123-875-11	ELECT	10MF	20%	50V	C806	1-124-636-00	ELECT	3300MF	20%	25V
C509	1-123-875-11	ELECT	10MF	20%	50V	C807	1-123-875-11	ELECT	10MF	20%	50V

# TC-K333ESR/K730ES

Ref.No.	Part No.	Description			
C808	1-124-122-11	ELECT	100MF	20%	35V
C809	1-126-129-11	ELECT	6800MF	20%	35V
C810	1-126-129-11	ELECT	6800MF	20%	35V
C811	1-136-165-00	FILM	0.1MF	5%	50V
C812	1-136-177-00	FILM	1MF	5%	50V
C821	1-124-443-00	ELECT	100MF	20%	10V
C901	1-163-059-00	CERAMIC CHIP	0.01MF	10%	50V
C902	1-163-063-00	CERAMIC CHIP	0.022MF	10%	50V
C903	1-163-063-00	CERAMIC CHIP	0.022MF	10%	50V
C904	1-163-077-00	CERAMIC CHIP	0.1MF		50V
C905	1-124-779-00	ELECT CHIP	10MF	20%	16V
C906	1-135-091-00	TANTAL. CHIP	1MF	10%	16V
C907	1-163-077-00	CERAMIC CHIP	0.1MF		50V
C908	1-163-077-00	CERAMIC CHIP	0.1MF		50V
C909	1-163-077-00	CERAMIC CHIP	0.1MF		50V
C910	1-163-063-00	CERAMIC CHIP	0.022MF	10%	50V
C911	1-124-779-00	ELECT CHIP	10MF	20%	16V
C1001	1-123-875-11	ELECT	10MF	20%	50V
C1002	1-123-875-11	ELECT	10MF	20%	50V
CN501	*1-560-062-00	PIN, CONNECTOR	4P		
CN502	*1-564-507-11	PLUG, CONNECTOR	4P		
CN503	*1-564-506-11	PLUG, CONNECTOR	3P		
CN504	*1-560-062-00	PIN, CONNECTOR	4P		
CN505	*1-560-061-00	PIN, CONNECTOR	3P		
CN506	*1-564-338-61	PIN, CONNECTOR	4P		
CN507	*1-564-340-00	PIN, CONNECTOR	6P		
CN508	*1-564-340-71	PIN, CONNECTOR	6P		
CN509	*1-564-338-00	PIN, CONNECTOR	4P		
CN510	*1-564-338-71	PIN, CONNECTOR	4P		
CN511	*1-564-338-81	PIN, CONNECTOR	4P		
CN512	*1-564-339-00	PIN, CONNECTOR	5P		
CN701	*1-564-508-11	PLUG, CONNECTOR	5P		
CN702	*1-564-337-00	PIN, CONNECTOR	3P		
CN703	*1-564-336-00	PIN, CONNECTOR	2P		
CN704	*1-564-340-00	PIN, CONNECTOR	6P		
CN705	*1-564-339-61	PIN, CONNECTOR	5P		
CN706	*1-564-339-00	PIN, CONNECTOR	5P		
CN707	*1-564-338-61	PIN, CONNECTOR	4P		
CN708	*1-564-338-00	PIN, CONNECTOR	4P		
CN709	*1-564-337-61	PIN, CONNECTOR	3P		
CN710	*1-564-342-11	PIN, CONNECTOR	8P		
CN711	*1-564-341-11	PIN, CONNECTOR	7P		
CN712	*1-564-507-11	PLUG, CONNECTOR	4P		
CP501	1-466-045-11	OSCILLATION UNIT, BIAS			
CT501	1-141-225-00	CAP, TUNING, TRIMAR			
D501	8-719-933-47	DIODE	HZS782L		
D502	8-719-933-71	DIODE	HZS11C3L		
D503	8-719-912-20	DIODE	1SS120		
D504	8-719-912-20	DIODE	1SS120		
D505	8-719-912-20	DIODE	1SS120		
D506	8-719-912-20	DIODE	1SS120		
D507	8-719-912-20	DIODE	1SS120		
D508	8-719-912-20	DIODE	1SS120		
D509	8-719-912-20	DIODE	1SS120		
D510	8-719-912-20	DIODE	1SS120		
D511	8-719-912-20	DIODE	1SS120		
D512	8-719-912-20	DIODE	1SS120		



Ref.No.	Part No.	Description
D513	8-719-114-29	DIODE RD5.1JS
D514	8-719-933-71	DIODE HZS11C3L
D515	8-719-933-71	DIODE HZS11C3L
D516	8-719-114-29	DIODE RD5.1JS
D701	8-719-933-41	DIODE HZS6C3L
D702	8-719-933-57	DIODE HZS981L
D703	8-719-933-36	DIODE HZS6B1L
D704	8-719-934-13	DIODE HZS24-1L
D705	8-719-114-29	DIODE RD5.1JSB1
D706	8-719-200-77	DIODE 10E2N
D707	8-719-200-77	DIODE 10E2N
D708	8-719-200-77	DIODE 10E2N
D709	8-719-900-79	DIODE BG5628S (▶)
D710	8-719-956-28	DIODE BR5628S (■)
D711	8-719-913-47	DIODE EAA5638S (●)
D712	8-719-912-29	DIODE 1SS120
D713	8-719-114-29	DIODE RD5.1JSB1
D714	8-719-912-20	DIODE 1SS120
D801	8-719-114-19	DIODE RD5.1JSB1
D802	8-719-912-20	DIODE 1SS120
D803	8-719-504-60	DIODE S2VB20
D804	8-719-200-77	DIODE 10E2N
D805	8-719-200-77	DIODE 10E2N
D806	8-719-934-18	DIODE HZS27-2L
D807	8-719-230-02	DIODE 30D4
D808	8-719-230-02	DIODE 30D4
D809	8-719-230-02	DIODE 30D4
D810	8-719-230-02	DIODE 30D4
D1001	8-719-107-94	DIODE 1SS132
D1002	8-719-107-94	DIODE 1SS132
EH501	1-543-358-11	HEAD, MAGNETIC (ERASE)
F801	△ 1-532-259-00	(AEP,UK,E).....FUSE, TIME-LAG (1.6A)
F801	△ 1-532-742-11	(US,Canadian)...FUSE, GLASS TUBE (1.6A)
F802	△ 1-532-259-00	(AEP,UK,E).....FUSE, TIME-LAG (1.6A)
F802	△ 1-532-742-11	(US,Canadian)...FUSE, GLASS TUBE (1.6A)
FL501	1-519-497-11	INDICATOR TUBE, FLUORESCENT
FL701	1-519-409-11	INDICATOR TUBE, FLUORESCENT (COUNTER)
H901	8-719-403-79	OH009-TW
H902	8-719-403-79	OH009-TW
H903	8-719-403-79	OH009-TW
IC501	8-759-604-38	IC M5F78M10
IC502	8-759-604-44	IC M5F79M10
IC503	8-759-602-01	IC M5220P
IC504	8-752-018-80	IC CX20188
IC505	8-759-602-83	IC M5238P
IC506	8-752-018-80	IC CX20188
IC507	8-759-981-96	IC RC45600
IC508	8-759-981-96	IC RC45600
IC509	8-759-145-58	IC UPC4558C
IC510	8-759-961-38	IC BA6138
IC511	8-759-982-26	IC RC78L12A
IC512	8-759-904-72	IC MSL9359RS
IC701	8-759-938-34	IC M888517B-228N
IC702	8-759-602-47	IC M50761-417P
IC703	8-759-601-45	IC M4069UBP

**Note:**  
The components identified by mark  or dotted line with mark  are critical for safety. Replace only with part number specified.

**Note:**  
Les composants identifiés par une marque  sont critiques pour la sécurité. Ne les remplacer que par une pièce portant le numéro spécifié.

Ref.No.	Part No.	Description
IC704	8-759-201-58	IC TC9142P
IC705	8-741-138-70	IC BX-1387
IC706	8-759-905-48	IC MSL9512RS
IC901	8-759-100-96	IC UPC4558G2
IC902	8-752-017-40	IC CX20174
J501	1-507-531-31	PLATE, PIN-JACK (LINE IN/OUT)
J502	1-507-796-71	JACK (HEADPHONES)
JR901	1-216-296-00	METAL GLAZE 0 5% 1/8W
JR902	1-216-296-00	METAL GLAZE 0 5% 1/8W
JR903	1-216-296-00	METAL GLAZE 0 5% 1/8W
JR904	1-216-296-00	METAL GLAZE 0 5% 1/8W
JR905	1-216-296-00	METAL GLAZE 0 5% 1/8W
L101	1-408-924-00	INDUCTOR 10MMH
L102	1-408-925-11	INDUCTOR 12MMH
L103	1-408-920-00	INDUCTOR 4.7MMH
L104	1-408-918-11	INDUCTOR 3.3MMH
L105	1-408-916-11	INDUCTOR 2.2MMH
L106	1-408-925-11	INDUCTOR 12MMH
L201	1-408-924-00	INDUCTOR 10MMH
L202	1-408-925-11	INDUCTOR 12MMH
L203	1-408-920-00	INDUCTOR 4.7MMH
L204	1-408-918-11	INDUCTOR 3.3MMH
L205	1-408-916-11	INDUCTOR 2.2MMH
L206	1-408-925-11	INDUCTOR 12MMH
L501	1-410-525-11	INDUCTOR 220UH
L502	1-410-525-11	INDUCTOR 220UH
L503	1-410-525-11	INDUCTOR 220UH
L1001	1-459-426-00	COIL (FG)
LPF101	1-236-087-11	FILTER, LOW PASS
LPF201	1-236-087-11	FILTER, LOW PASS
M901	X-3575-382-1	MOTOR ASSY, REEL
PH501	8-825-770-51	HEAD, REC/PB RPA230-3602C (Including RH501)
PL1001	1-518-313-00	LAMP, PILOT
PM901	1-454-333-00	SOLENOID, PLUNGER
PM902	1-454-291-00	SOLENOID, PLUNGER
PT801A	1-448-948-11	(US, Canadian)... TRANSFORMER, POWER
PT801B	1-448-949-11	(AEP, UK)..... TRANSFORMER, POWER
PT801C	1-449-005-11	(E)..... TRANSFORMER, POWER
Q101	8-729-107-84	TRANSISTOR 2SC3623A-L
Q102	8-729-102-04	TRANSISTOR 2SD1020-F
Q103	8-729-107-84	TRANSISTOR 2SC3623A-L
Q104	8-729-107-84	TRANSISTOR 2SC3623A-L
Q105	8-729-107-84	TRANSISTOR 2SC3623A-L
Q106	8-729-107-84	TRANSISTOR 2SC3623A-L
Q201	8-729-107-84	TRANSISTOR 2SC3623A-L
Q202	8-729-102-04	TRANSISTOR 2SD1020-F
Q203	8-729-107-84	TRANSISTOR 2SC3623A-L
Q204	8-729-107-84	TRANSISTOR 2SC3623A-L
Q205	8-729-107-84	TRANSISTOR 2SC3623A-L
Q206	8-729-107-84	TRANSISTOR 2SC3623A-L
Q501	8-729-900-63	TRANSISTOR DTA124ES
Q502	8-729-900-89	TRANSISTOR DTC144ES
Q503	8-729-900-36	TRANSISTOR DTC124ES

Ref.No.	Part No.	Description
Q504	8-729-900-36	TRANSISTOR DTC124ES
Q505	8-729-900-36	TRANSISTOR DTC124ES
Q506	8-729-900-36	TRANSISTOR DTC124ES
Q507	8-729-900-36	TRANSISTOR DTC124ES
Q508	8-729-281-53	TRANSISTOR 2SC1815GR
Q509	8-729-281-53	TRANSISTOR 2SC1815GR
Q510	8-729-178-54	TRANSISTOR 2SC2785
Q511	8-729-900-63	TRANSISTOR DTA124ES
Q512	8-729-900-36	TRANSISTOR DTC144ES
Q513	8-729-117-54	TRANSISTOR 2SA1175
Q514	8-729-178-54	TRANSISTOR 2SC2785
Q515	8-729-900-65	TRANSISTOR DTA144ES
Q516	8-729-900-65	TRANSISTOR DTA144ES
Q517	8-729-900-65	TRANSISTOR DTA144ES
Q518	8-729-900-65	TRANSISTOR DTA144ES
Q519	8-729-900-65	TRANSISTOR DTA144ES
Q520	8-729-900-65	TRANSISTOR DTA144ES
Q521	8-729-900-89	TRANSISTOR DTC144ES
Q701	8-729-107-25	TRANSISTOR 2SD1585-L
Q702	8-729-107-25	TRANSISTOR 2SD1585-L
Q703	8-729-107-25	TRANSISTOR 2SD1585-L
Q704	8-729-107-25	TRANSISTOR 2SD1585-L
Q705	8-729-107-25	TRANSISTOR 2SD1585-L
Q706	8-729-178-54	TRANSISTOR 2SC2785
Q707	8-729-178-54	TRANSISTOR 2SC2785
Q708	8-729-178-54	TRANSISTOR 2SC2785
Q709	8-729-178-54	TRANSISTOR 2SC2785
Q710	8-729-178-54	TRANSISTOR 2SC2785
Q711	8-729-802-34	TRANSISTOR 2SD1388
Q712	8-729-900-80	TRANSISTOR DTC114ES
Q713	8-729-802-34	TRANSISTOR 2SD1388
Q714	8-729-900-80	TRANSISTOR DTC144ES
Q715	8-729-802-22	TRANSISTOR 2SB1014
Q716	8-729-802-22	TRANSISTOR 2SB1014
Q717	8-729-900-80	TRANSISTOR DTC144ES
Q718	8-729-801-93	TRANSISTOR 2SD1387
Q719	8-729-801-93	TRANSISTOR 2SD1387
Q720	8-729-801-83	TRANSISTOR 2SB1013
Q721	8-729-801-83	TRANSISTOR 2SB1013
Q722	8-729-900-61	TRANSISTOR DTA114ES
Q801	8-729-180-92	TRANSISTOR 2SD809-K
Q1001	8-729-110-22	TRANSISTOR PH102
Q1002	8-729-110-22	TRANSISTOR PH102
R101	1-249-466-11	CARBON 56K 5% 1/4W
R102	1-249-652-11	CARBON 130 5% 1/2W
R103	1-249-602-11	CARBON 120K 5% 1/4W
R104	1-247-255-00	CARBON 4.3K 5% 1/2W
R105	1-249-537-11	CARBON 240 5% 1/4W
R106	1-249-539-11	CARBON 300 5% 1/4W
R107	1-249-429-11	CARBON 10K 5% 1/4W
R108	1-247-717-11	CARBON 2.2K 5% 1/4W
R109	1-249-928-11	CARBON 1.6K 5% 1/4W
R110	1-247-749-11	CARBON 560 5% 1/2W
R111	1-247-764-11	CARBON 10K 5% 1/2W
R112	1-247-146-00	CARBON 4.3K 5% 1/4W

<p><b>Note:</b> The components identified by mark  or dotted line with mark  are critical for safety. Replace only with part number specified.</p>	<p><b>Note:</b> Les composants identifiés par une marque  sont critiques pour la sécurité. Ne les remplacer que par une pièce portant le numéro spécifié.</p>
--	--

# TC-K333ESR/K730ES

Ref.No.	Part No.	Description							
R113	1-247-142-00	CARBON	3K	5%	1/4W				
R114	1-246-545-00	CARBON	1M	5%	1/4W				
R115	1-249-917-11	CARBON	560	1%	1/4W				
R116	1-247-193-00	CARBON	22K	1%	1/4W				
R117	1-247-152-00	CARBON	7.5K	5%	1/4W				
R118	1-247-711-11	CARBON	680	5%	1/4W				
R119	1-247-154-00	CARBON	9.1K	5%	1/4W				
R120	1-249-465-11	CARBON	47K	5%	1/4W				
R121	1-249-490-11	CARBON	27K	5%	1/2W				
R122	1-249-824-11	CARBON	8.2K	5%	1/2W				
R123	1-249-469-11	CARBON	100K	5%	1/4W				
R124	1-247-723-11	CARBON	6.8K	5%	1/4W				
R125	1-247-720-11	CARBON	3.9K	5%	1/4W				
R126	1-247-719-11	CARBON	3.3K	5%	1/4W				
R127	1-247-152-00	CARBON	7.5K	5%	1/4W				
R128	1-249-469-11	CARBON	100K	5%	1/4W				
R129	1-247-747-11	CARBON	470	5%	1/2W				
R130	1-247-764-11	CARBON	10K	5%	1/2W				
R131	1-247-146-00	CARBON	4.3K	5%	1/4W				
R132	1-247-142-00	CARBON	3K	5%	1/4W				
R133	1-246-545-00	CARBON	1M	5%	1/4W				
R134	1-249-917-11	CARBON	560	1%	1/4W				
R135	1-247-193-00	CARBON	22K	1%	1/4W				
R136	1-247-152-00	CARBON	7.5K	5%	1/4W				
R137	1-247-711-11	CARBON	680	5%	1/4W				
R138	1-247-154-00	CARBON	9.1K	5%	1/4W				
R139	1-249-465-11	CARBON	47K	5%	1/4W				
R140	1-247-721-11	CARBON	4.7K	5%	1/4W				
R141	1-249-461-11	CARBON	18K	5%	1/4W				
R142	1-247-719-11	CARBON	3.3K	5%	1/4W				
R143	1-247-723-11	CARBON	6.8K	5%	1/4W				
R144	1-249-425-11	CARBON	4.7K	5%	1/4W				
R145	1-249-590-11	CARBON	39K	5%	1/4W				
R146	1-249-429-11	CARBON	10K	5%	1/4W				
R147	1-249-469-11	CARBON	100K	5%	1/4W				
R148	1-249-459-11	CARBON	12K	5%	1/4W				
R149	1-247-717-11	CARBON	2.2K	5%	1/4W				
R150	1-249-466-11	CARBON	56K	5%	1/4W				
R151	1-249-590-11	CARBON	39K	5%	1/4W				
R152	1-247-703-11	CARBON	180	5%	1/4W				
R153	1-249-459-11	CARBON	12K	5%	1/4W				
R154	1-247-700-11	CARBON	100	5%	1/4W				
R155	1-247-142-00	CARBON	3K	5%	1/4W				
R156	1-247-721-11	CARBON	4.7K	5%	1/4W				
R157	1-249-429-11	CARBON	10K	5%	1/4W				
R158	1-249-429-11	CARBON	10K	5%	1/4W				
R159	1-247-700-11	CARBON	100	5%	1/4W				
R160	1-247-718-11	CARBON	2.7K	5%	1/4W				
R161	1-247-720-11	CARBON	3.9K	5%	1/4W				
R162	1-249-429-11	CARBON	10K	5%	1/4W				
R163	1-247-718-11	CARBON	2.7K	5%	1/4W				
R164	1-247-714-11	CARBON	1.2K	5%	1/4W				
R165	1-247-721-11	CARBON	4.7K	5%	1/4W				
R166	1-249-461-11	CARBON	18K	5%	1/4W				
R167	1-249-469-11	CARBON	100K	5%	1/4W				
R168	1-247-704-11	CARBON	220	5%	1/4W				
R169	1-247-749-11	CARBON	560	5%	1/2W				
R170	1-249-421-11	CARBON	2.2K	5%	1/4W				
R171	1-249-397-11	CARBON	22	5%	1/4W				
R172	1-247-883-00	CARBON	150K	5%	1/4W				
R173	1-249-429-11	CARBON	10K	5%	1/4W				
R174	1-247-725-11	CARBON	10K	5%	1/4W				
R175	1-249-441-11	CARBON	100K	5%	1/4W				
R201	1-249-466-11	CARBON	56K	5%	1/4W				
R202	1-249-652-11	CARBON	130	5%	1/2W				
R203	1-249-602-11	CARBON	120K	5%	1/4W				
R204	1-247-255-00	CARBON	4.3K	5%	1/2W				
R205	1-249-537-11	CARBON	240	5%	1/4W				
R206	1-249-539-11	CARBON	300	5%	1/4W				
R207	1-249-429-11	CARBON	10K	5%	1/4W				
R208	1-247-717-11	CARBON	2.2K	5%	1/4W				
R209	1-249-928-11	CARBON	1.6K	5%	1/4W				
R210	1-247-749-11	CARBON	560	5%	1/2W				
R211	1-247-764-11	CARBON	10K	5%	1/2W				
R212	1-247-146-00	CARBON	4.3K	5%	1/4W				
R213	1-247-142-00	CARBON	3K	5%	1/4W				
R214	1-246-545-00	CARBON	1M	5%	1/4W				
R215	1-249-917-11	CARBON	560	1%	1/4W				
R216	1-247-193-00	CARBON	22K	1%	1/4W				
R217	1-247-152-00	CARBON	7.5K	5%	1/4W				
R218	1-247-711-11	CARBON	680	5%	1/4W				
R219	1-247-154-00	CARBON	9.1K	5%	1/4W				
R220	1-249-465-11	CARBON	47K	5%	1/4W				
R221	1-249-490-11	CARBON	27K	5%	1/2W				
R222	1-249-824-11	CARBON	8.2K	5%	1/2W				
R223	1-249-469-11	CARBON	100K	5%	1/4W				
R224	1-247-723-11	CARBON	6.8K	5%	1/4W				
R225	1-247-720-11	CARBON	3.9K	5%	1/4W				
R226	1-247-719-11	CARBON	3.3K	5%	1/4W				
R227	1-247-152-00	CARBON	7.5K	5%	1/4W				
R228	1-249-469-11	CARBON	100K	5%	1/4W				
R229	1-247-747-11	CARBON	470	5%	1/2W				
R230	1-247-764-11	CARBON	10K	5%	1/2W				
R231	1-247-146-00	CARBON	4.3K	5%	1/4W				
R232	1-247-142-00	CARBON	3K	5%	1/4W				
R233	1-246-545-00	CARBON	1M	5%	1/4W				
R234	1-249-917-11	CARBON	560	1%	1/4W				
R235	1-247-193-00	CARBON	22K	1%	1/4W				
R236	1-247-152-00	CARBON	7.5K	5%	1/4W				
R237	1-247-711-11	CARBON	680	5%	1/4W				
R238	1-247-154-00	CARBON	9.1K	5%	1/4W				
R239	1-249-465-11	CARBON	47K	5%	1/4W				
R240	1-247-721-11	CARBON	4.7K	5%	1/4W				
R241	1-249-461-11	CARBON	18K	5%	1/4W				
R242	1-247-719-11	CARBON	3.3K	5%	1/4W				
R243	1-247-723-11	CARBON	6.8K	5%	1/4W				
R244	1-249-425-11	CARBON	4.7K	5%	1/4W				
R245	1-249-590-11	CARBON	39K	5%	1/4W				
R246	1-249-429-11	CARBON	10K	5%	1/4W				
R247	1-249-469-11	CARBON	100K	5%	1/4W				
R248	1-249-459-11	CARBON	12K	5%	1/4W				
R249	1-247-717-11	CARBON	2.2K	5%	1/4W				
R250	1-249-466-11	CARBON	56K	5%	1/4W				
R251	1-249-590-11	CARBON	39K	5%	1/4W				



Ref.No.	Part No.	Description							
R252	1-247-703-11	CARBON	180	5%	1/4W				
R253	1-249-459-11	CARBON	12K	5%	1/4W				
R254	1-247-700-11	CARBON	100	5%	1/4W				
R255	1-247-142-00	CARBON	3K	5%	1/4W				
R256	1-247-721-11	CARBON	4.7K	5%	1/4W				
R257	1-249-429-11	CARBON	10K	5%	1/4W				
R258	1-249-429-11	CARBON	10K	5%	1/4W				
R259	1-247-700-11	CARBON	100	5%	1/4W				
R260	1-247-718-11	CARBON	2.7K	5%	1/4W				
R261	1-247-720-11	CARBON	3.9K	5%	1/4W				
R262	1-249-429-11	CARBON	10K	5%	1/4W				
R263	1-247-718-11	CARBON	2.7K	5%	1/4W				
R264	1-247-714-11	CARBON	1.2K	5%	1/4W				
R265	1-247-721-11	CARBON	4.7K	5%	1/4W				
R266	1-249-461-11	CARBON	18K	5%	1/4W				
R267	1-249-469-11	CARBON	100K	5%	1/4W				
R268	1-247-704-11	CARBON	220	5%	1/4W				
R269	1-247-749-11	CARBON	560	5%	1/2W				
R270	1-249-421-11	CARBON	2.2K	5%	1/4W				
R271	1-249-397-11	CARBON	22	5%	1/4W				
R272	1-247-883-00	CARBON	150K	5%	1/4W				
R273	1-249-429-11	CARBON	10K	5%	1/4W				
R274	1-247-725-11	CARBON	10K	5%	1/4W				
R275	1-249-441-11	CARBON	100K	5%	1/4W				
R501	1-249-433-11	CARBON	22K	5%	1/4W				
R502	1-215-472-00	METAL	130K	1%	1/6W				
R503	1-249-429-11	CARBON	10K	5%	1/4W				
R504	1-215-472-00	METAL	130K	1%	1/6W				
R505	1-249-429-11	CARBON	10K	5%	1/4W				
R506	1-249-438-11	CARBON	56K	5%	1/4W				
R507	1-249-433-11	CARBON	22K	5%	1/4W				
R508	1-249-421-11	CARBON	2.2K	5%	1/4W				
R509	1-249-429-11	CARBON	10K	5%	1/4W				
R510	1-249-438-11	CARBON	56K	5%	1/4W				
R511	1-249-438-11	CARBON	56K	5%	1/4W				
R512	1-249-438-11	CARBON	56K	5%	1/4W				
R513	1-249-433-11	CARBON	22K	5%	1/4W				
R514	1-249-438-11	CARBON	56K	5%	1/4W				
R515	1-249-429-11	CARBON	10K	5%	1/4W				
R516	1-249-433-11	CARBON	22K	5%	1/4W				
R517	1-249-437-11	CARBON	47K	5%	1/4W				
R518	1-249-438-11	CARBON	56K	5%	1/4W				
R519	1-247-862-11	CARBON	20K	5%	1/4W				
R520	1-247-848-11	CARBON	5.1K	5%	1/4W				
R521	1-249-425-11	CARBON	4.7K	5%	1/4W				
R522	1-247-846-11	CARBON	4.3K	5%	1/4W				
R523	1-249-425-11	CARBON	4.7K	5%	1/4W				
R524	1-249-417-11	CARBON	1K	5%	1/4W				
R525	1-249-437-11	CARBON	47K	5%	1/4W				
R526	1-249-433-11	CARBON	22K	5%	1/4W				
R527	1-247-700-11	CARBON	100	5%	1/4W				
R528	1-247-700-11	CARBON	100	5%	1/4W				
R529	1-249-429-11	CARBON	10K	5%	1/4W				
R530	1-249-437-11	CARBON	47K	5%	1/4W				
R531	1-247-700-11	CARBON	100	5%	1/4W				
R532	1-247-700-11	CARBON	100	5%	1/4W				
R533	1-249-433-11	CARBON	22K	5%	1/4W				
R534	1-249-441-11	CARBON	100K	5%	1/4W				
R535	1-249-441-11	CARBON	100K	5%	1/4W				
R536	1-249-441-11	CARBON	100K	5%	1/4W				
R537	1-249-441-11	CARBON	100K	5%	1/4W				
R538	1-249-441-11	CARBON	100K	5%	1/4W				
R539	1-249-441-11	CARBON	100K	5%	1/4W				
R540	1-249-441-11	CARBON	100K	5%	1/4W				
R541	1-249-441-11	CARBON	100K	5%	1/4W				
R542	1-249-410-11	CARBON	270	5%	1/4W				
R543	1-249-410-11	CARBON	270	5%	1/4W				
R544	1-247-887-00	CARBON	220K	5%	1/4W				
R545	1-249-432-11	CARBON	18K	5%	1/4W				
R546	1-249-429-11	CARBON	10K	5%	1/4W				
R547	1-249-429-11	CARBON	10K	5%	1/4W				
R548	1-249-405-11	CARBON	100	5%	1/4W				
R549	1-249-405-11	CARBON	100	5%	1/4W				
R550	1-249-405-11	CARBON	100	5%	1/4W				
R551	1-249-405-11	CARBON	100	5%	1/4W				
R552	1-249-405-11	CARBON	100	5%	1/4W				
R553	1-249-405-11	CARBON	100	5%	1/4W				
R554	1-249-405-11	CARBON	100	5%	1/4W				
R555	1-249-405-11	CARBON	100	5%	1/4W				
R556	1-249-405-11	CARBON	100	5%	1/4W				
R557	1-249-405-11	CARBON	100	5%	1/4W				
R701	1-247-721-11	CARBON	4.7K	5%	1/4W				
R702	1-249-437-11	CARBON	47K	5%	1/4W				
R703	1-249-421-11	CARBON	2.2K	5%	1/4W				
R704	1-247-717-11	CARBON	2.2K	5%	1/4W				
R705	1-249-437-11	CARBON	47K	5%	1/4W				
R706	1-249-421-11	CARBON	2.2K	5%	1/4W				
R707	1-247-717-11	CARBON	2.2K	5%	1/4W				
R708	1-247-717-11	CARBON	2.2K	5%	1/4W				
R709	1-249-437-11	CARBON	47K	5%	1/4W				
R710	1-249-421-11	CARBON	2.2K	5%	1/4W				
R711	1-247-708-11	CARBON	470	5%	1/4W				
R712	1-247-713-11	CARBON	1K	5%	1/4W				
R713	1-247-717-11	CARBON	2.2K	5%	1/4W				
R714	1-249-437-11	CARBON	47K	5%	1/4W				
R715	1-249-421-11	CARBON	2.2K	5%	1/4W				
R716	1-247-721-11	CARBON	4.7K	5%	1/4W				
R717	1-247-891-00	CARBON	330K	5%	1/4W				
R718	1-249-441-11	CARBON	100K	5%	1/4W				
R719	1-249-417-11	CARBON	1K	5%	1/4W				
R720	1-249-417-11	CARBON	1K	5%	1/4W				
R721	1-249-429-11	CARBON	10K	5%	1/4W				
R722	1-247-717-11	CARBON	2.2K	5%	1/4W				
R723	1-249-437-11	CARBON	47K	5%	1/4W				
R724	1-247-729-11	CARBON	15	5%	1/2W				
R725	1-249-429-11	CARBON	10K	5%	1/4W				
R726	1-247-717-11	CARBON	2.2K	5%	1/4W				
R727	1-249-437-11	CARBON	47K	5%	1/4W				
R728	1-249-429-11	CARBON	10K	5%	1/4W				
R729	1-249-417-11	CARBON	1K	5%	1/4W				
R730	1-249-417-11	CARBON	1K	5%	1/4W				
R731	1-249-429-11	CARBON	10K	5%	1/4W				
R732	1-249-417-11	CARBON	1K	5%	1/4W				
R733	1-249-429-11	CARBON	10K	5%	1/4W				

# TC-K333ESR/K730ES

Ref.No.	Part No.	Description			
R734	1-249-417-11	CARBON	1K	5%	1/4W
R735	1-249-429-11	CARBON	10K	5%	1/4W
R736	1-247-711-11	CARBON	680	5%	1/4W
R737	1-247-715-11	CARBON	1.5K	5%	1/4W
R738	△ 1-212-849-00	FUSIBLE	4.7	5%	1/4W F
R739	1-249-437-11	CARBON	47K	5%	1/4W
R740	1-249-437-11	CARBON	47K	5%	1/4W
R741	1-247-883-00	CARBON	150K	5%	1/4W
R742	1-247-883-00	CARBON	150K	5%	1/4W
R743	1-249-417-11	CARBON	1K	5%	1/4W
R744	1-249-433-11	CARBON	22K	5%	1/4W
R745	1-249-433-11	CARBON	22K	5%	1/4W
R746	1-249-433-11	CARBON	22K	5%	1/4W
R747	1-249-433-11	CARBON	22K	5%	1/4W
R748	1-249-417-11	CARBON	1K	5%	1/4W
R749	1-249-417-11	CARBON	1K	5%	1/4W
R750	1-249-430-11	CARBON	12K	5%	1/4W
R751	1-249-430-11	CARBON	12K	5%	1/4W
R752	1-249-433-11	CARBON	22K	5%	1/4W
R753	1-249-433-11	CARBON	22K	5%	1/4W
R754	1-249-433-11	CARBON	22K	5%	1/4W
R755	1-249-433-11	CARBON	22K	5%	1/4W
R756	1-249-433-11	CARBON	22K	5%	1/4W
R757	1-249-433-11	CARBON	22K	5%	1/4W
R758	1-249-433-11	CARBON	22K	5%	1/4W
R759	1-249-441-11	CARBON	100K	5%	1/4W
R760	1-249-429-11	CARBON	10K	5%	1/4W
R761	1-249-413-11	CARBON	470	5%	1/4W
R762	1-249-413-11	CARBON	470	5%	1/4W
R763	1-249-413-11	CARBON	470	5%	1/4W
R764	1-249-413-11	CARBON	470	5%	1/4W
R765	1-249-409-11	CARBON	220	5%	1/4W
R766	1-249-413-11	CARBON	470	5%	1/4W
R767	1-249-410-11	CARBON	270	5%	1/4W
R768	1-249-417-11	CARBON	1K	5%	1/4W
R769	1-249-417-11	CARBON	1K	5%	1/4W
R770	1-249-432-11	CARBON	18K	5%	1/4W
R771	1-249-430-11	CARBON	12K	5%	1/4W
R772	1-249-433-11	CARBON	22K	5%	1/4W
R773	1-249-422-11	CARBON	2.7K	5%	1/4W
R774	1-247-903-00	CARBON	1M	5%	1/4W
R775	1-249-433-11	CARBON	22K	5%	1/4W
R776	1-249-429-11	CARBON	10K	5%	1/4W
R777	1-249-426-11	CARBON	5.6K	5%	1/4W
R778	1-249-430-11	CARBON	12K	5%	1/4W

Ref.No.	Part No.	Description			
R779	1-249-433-11	CARBON	22K	5%	1/4W
R780	1-249-431-11	CARBON	15K	5%	1/4W
R781	1-249-430-11	CARBON	12K	5%	1/4W
R782	1-249-426-11	CARBON	5.6K	5%	1/4W
R783	1-249-429-11	CARBON	10K	5%	1/4W
R784	1-249-433-11	CARBON	22K	5%	1/4W
R785	1-249-431-11	CARBON	15K	5%	1/4W
R786	1-249-433-11	CARBON	22K	5%	1/4W
R787	1-249-458-11	CARBON	8.2	5%	1/4W
R788	1-247-747-11	CARBON	470	5%	1/2W
R789	1-249-429-11	CARBON	10K	5%	1/4W
R790	1-247-694-11	CARBON	33	5%	1/4W
R795	1-247-901-11	CARBON	820K	5%	1/4W
R799	1-247-747-11	CARBON	470	5%	1/2W
R801	1-247-713-11	CARBON	1K	5%	1/4W
R802	1-247-721-11	CARBON	4.7K	5%	1/4W
R803	1-249-437-11	CARBON	47K	5%	1/4W
R804	△ 1-212-861-11	FUSIBLE	15	5%	1/4W F
R901	1-216-198-00	METAL GLAZE	1K	5%	1/8W
R902	1-216-198-00	METAL GLAZE	1K	5%	1/8W
R903	1-216-238-00	METAL GLAZE	47K	5%	1/8W
R904	1-216-198-00	METAL GLAZE	1K	5%	1/8W
R905	1-216-224-00	METAL GLAZE	12K	5%	1/8W
R906	1-216-217-00	METAL GLAZE	6.2K	5%	1/8W
R907	1-216-242-00	METAL GLAZE	68K	5%	1/8W
R908	1-216-246-00	METAL GLAZE	100K	5%	1/8W
R909	1-216-246-00	METAL GLAZE	100K	5%	1/8W
R910	1-216-238-00	METAL GLAZE	47K	5%	1/8W
R911	1-216-182-00	METAL GLAZE	220	5%	1/8W
R912	1-216-182-00	METAL GLAZE	220	5%	1/8W
R913	1-216-150-00	METAL GLAZE	10	5%	1/8W
R914	1-216-150-00	METAL GLAZE	10	5%	1/8W
R915	1-216-150-00	METAL GLAZE	10	5%	1/8W
RV101	1-224-251-XX	RES, ADJ, METAL GLAZE	4.7K(PB LEVEL L)		
RV102	1-224-251-XX	RES, ADJ, METAL GLAZE	4.7K(REC LEVEL L)		
RV103	1-237-459-21	RES, ADJ, CARBON	10K (LEVEL METER L)		
RV201	1-224-251-XX	RES, ADJ, METAL GLAZE	4.7K(PB LEVEL R)		
RV202	1-224-251-XX	RES, ADJ, METAL GLAZE	4.7K(REC LEVEL R)		
RV203	1-237-459-21	RES, ADJ, CARBON	10K (LEVEL METER R)		
RV501	1-230-344-11	RES, VAR, CARBON	20K/20K (REC LEVEL)		
RV502	1-237-389-11	RES, VAR, CARBON	5K/5K (CALIBRATION REC LEVEL)		
RV503	1-237-388-11	RES, VAR, CARBON	20K/20K (PHONE LEVEL)		
RV504	1-226-560-00	RES, VAR, CARBON	5K (CALIBRATION BIAS)		
RV505	1-237-456-11	RES, ADJ, CARBON	1K (NORMAL BIAS 1)		



**Note:**  
The components identified by mark △ or dotted line with mark △ are critical for safety. Replace only with part number specified.

**Note:**  
Les composants identifiés par une marque △ sont critiques pour la sécurité. Ne les remplacer que par une pièce portant le numéro spécifié.

Ref.No.	Part No.	Description
RV506	1-237-455-11	RES, ADJ, CARBON 500(NORMAL BIAS IV)
RV701	1-228-990-00	RES, ADJ, CARBON 1K (FWD TORQUE)
RY501	1-515-614-11	RELAY (LINE MUTE)
S501	1-554-338-00	SWITCH, LEVER SLIDE (MONITOR)
S502	1-571-092-11	SWITCH, PUSH (4 KEY) (DOLBY NR,MPX FILTER)
S701	1-554-303-21	SWITCH, KEY BOARD (■)
S702	1-554-303-21	SWITCH, KEY BOARD (◀◀)
S703	1-554-303-21	SWITCH, KEY BOARD (▶▶)
S704	1-554-303-21	SWITCH, KEY BOARD (REC ●)
S705	1-554-303-21	SWITCH, KEY BOARD (▶)
S706	1-554-303-21	SWITCH, KEY BOARD (PAUSE ■■)
S707	1-554-303-21	SWITCH, KEY BOARD (REC MUTE ●)
S708	1-554-303-21	SWITCH, KEY BOARD (COUNTER RESET)
S709	1-554-303-21	SWITCH, KEY BOARD (COUNTER MEMORY)
S710	1-516-781-XX	SWITCH, ROTARY (TIMER)
S801	1-554-920-11	SWITCH, PUSH (AC POWER)(1 KEY)
S802	1-570-307-11	(E)...SWITCH, VOLTAGE CHANGE
S1001	1-554-205-00	SWITCH, PUSH (ERASE PROOF)
S1002	1-554-205-00	SWITCH, PUSH (HALF DET)
S1003	1-554-205-00	SWITCH, PUSH (LOCK DET)
S1004	1-554-205-00	SWITCH, PUSH (METAL)
S1005	1-554-205-00	SWITCH, PUSH (CrO2)
TH501	1-800-200-00	THERMISTOR S-3K
THP501	1-202-856-00	SOLID 22 1/4W F
X701	1-567-160-00	OSCILLATOR, CERAMIC (4.19MHz)
X702	1-527-532-00	OSCILLATOR, CERAMIC (400kHz)
X703	1-567-731-11	VIBRATOR, CRYSTAL (10.5MHz)

ACCESSORY & PACKING MATERIAL

1-465-104-11	{UK}...REMOTE COMMANDER (RM-J600)
1-551-734-11	CORD, CONNECTION (RK-74A)
*3-318-684-01	CUSHION
*3-350-429-01	{US,Canadian,AEP}...INDIVIDUAL CARTON
*3-350-429-11	{E}.....INDIVIDUAL CARTON
*3-350-437-01	{UK}.....INDIVIDUAL CARTON
3-701-630-00	BAG, POLYETHYLENE
3-703-450-01	{US}...INSTRUCTION
3-786-746-21	{US,Canadian,UK,E}...MANUAL, INSTRUCTION
3-786-746-41	{AEP}.....MANUAL, INSTRUCTION
3-786-746-51	{Canadian,AEP}.....MANUAL, INSTRUCTION
3-793-481-13	INSTRUCTION
4-384-285-01	{UK}...COVER, BATTERY
4-820-330-31	{EXCEPT UK}...SCREW, BW, PLUS MINUS

**Note:**  
The components identified by mark  or dotted line with mark  are critical for safety. Replace only with part number specified.

**Note:**  
Les composants identifiés par une marque  sont critiques pour la sécurité. Ne les remplacer que par une pièce portant le numéro spécifié.

**TC-K333ESR/K730ES**

**9-953-769-11**

**Sony Corporation**  
Audio Group

—48—

**English**  
89D0480-1  
Printed in Japan  
©1989. 4

Published by A/V Engineering Service Dept.