

TC-K333ESG/K950ES

SERVICE MANUAL

US Model
Canadian Model
AEP Model
UK Model
TC-K950ES
E Model
TC-K333ESG



TC-K333ESG

Dolby noise reduction manufactured under license from
Dolby Laboratories Licensing Corporation.
"DOLBY" and the double-D symbol  are trademarks of
Dolby Laboratories Licensing Corporation.

Model Name Using Similar Mechanism	New
Tape Transport Mechanism Type	TCM-200D1

SPECIFICATIONS

Recording system	4-track 2-channel stereo
Bias	AC bias
Heads	Erase head × 1 (S&F head) Recording head × 1 (LA head) Playback head × 1 (LA head)
Motors	Capstan motor × 1 (direct drive linear torque BSL motor) Reel motor × 1 (DC motor)
Wow and flutter	0.024% WRMS (NAB)
Fast-forward and rewind time	Approx. 90 sec. (with C-60 cassette)

Frequency response (DOLBY NR OFF)

TYPE IV cassette (Sony METAL-ES)	15–22,000 Hz (±3 dB, DIN) 15–16,000 Hz (OVU recording)
TYPE II cassette (Sony UX-S)	15–20,000 Hz (±3 dB, DIN)
TYPE I cassette (Sony HF-S)	15–18,000 Hz (±3 dB, DIN)

Signal-to-noise ratio (at peak level)

Cassette	Dolby NR switch	OFF	B-TYPE ON	C-TYPE ON
	TYPE IV (Sony METAL-ES)		61 dB	70 dB
TYPE II (Sony UX-S)		59 dB	68 dB	74 dB
TYPE I (Sony HF-S)		57 dB	66 dB	72 dB

Total harmonic distortion

0.8% (with Sony METAL-ES cassette)

Inputs		
Line inputs (phono jacks)	Sensitivity	77.5 mV (–20 dB)
	Input impedance	50k ohms
CD DIRECT INPUT	Input impedance	50k ohms

Outputs

Line outputs (phono jacks)	Rated output level	0.44 V (–5 dB) at a load impedance 47k ohms
	Load impedance	Over 10k ohms
Headphones (stereo phone jack)	Output level	0–3 mW at a load impedance of 32 ohms

General

Power requirements	AEP model : 220 V AC, 50/60 Hz UK model : 240 V AC, 50 Hz US, Canadian models : 120 V AC, 60 Hz E model : 120, 220, or 240 V AC adjustable, 50/60 Hz
Power consumption	31 W
Dimensions	Except UK model : Approx. 470 × 140 × 380 mm (w/h/d) (18 3/4 × 5 1/4 × 15 inches) UK model : Approx. 430 × 140 × 380 (17 × 5 1/4 × 15 inches) including projecting parts and controls
Weight	Approx. 11.7 kg (25 lbs 13 oz) Model for the United Kingdom: Approx. 11 kg (24 lbs 5 oz)
Supplied accessories	Audio connecting cord (2) Wireless remote control unit RM-J702 (1) Sony R6 (size-AA) batteries (2) Screws (8) (Except UK model)
A remote commander and Sony R6 batteries are supplied with UK, E models.	

Design and specifications subject to change without notice.

Note

This appliance conforms with EEC Directive 87/308/EEC
regarding interference suppression.

STEREO CASSETTE DECK
SONY®

TABLE OF CONTENTS

<u>Section</u>	<u>Title</u>	<u>Page</u>
SPECIFICATIONS.....		1
MODEL IDENTIFICATION		3
SAFETY CHECK-OUT.....		3
1. GENERAL		4
2. DISASSEMBLY.....		5
3. ADJUSTMENTS		
3-1. Mechanical Adjustments		7
3-2. Electrical Adjustments		10
4. DIAGRAMS		
4-1-1. IC Block Diagrams		15
4-2-1. IC503, 505 (CX20188) Pin Functions		15
4-2-2. IC801 (M50964-220SP) Pin Functions ..		16
4-1-2. IC Block Diagrams		17
4-3. Block Diagram		17
4-4. Semiconductor Lead Layouts		21
4-5. Circuit Boards Location		21
4-6. Printed Wiring Boards		
- Audio Section -		22
4-7. Schematic Diagram		
- Audio Section -		27
4-8. Printed Wiring Boards		
- Syscon Section -		32
4-9. Schematic Diagram		
- Syscon section -		37
5. EXPLODED VIEWS		
5-1. Panel Section		42
5-2. Chassis Section		44
5-3. Mechanism Section (1)		
(TCM-200D1)		45
5-4. Mechanism Section (2)		
(TCM-200D1)		46
6. ELECTRICAL PARTS LIST.....		47

SAFETY-RELATED COMPONENT WARNING!!

COMPONENTS IDENTIFIED BY MARK **▲** OR DOTTED LINE WITH MARK **▲** ON THE SCHEMATIC DIAGRAMS AND IN THE PARTS LIST ARE CRITICAL TO SAFE OPERATION. REPLACE THESE COMPONENTS WITH SONY PARTS WHOSE PART NUMBERS APPEAR AS SHOWN IN THIS MANUAL OR IN SUPPLEMENTS PUBLISHED BY SONY.

Flexible Circuit Board Repairing

- Keep the temperature of the soldering iron around 270°C during repairing.
- Do not touch the soldering iron on the same conductor of the circuit board (within 3 times).
- Be careful not to apply force on the conductor when soldering or unsoldering.

Notes on chip component replacement

- Never reuse a disconnected chip component.
- Notice that the minus side of a tantalum capacitor may be damaged by heat.

Dolby noise reduction and HX Pro headroom extension manufactured under license from Dolby Laboratories Licensing Corporation. HX Pro originated by Bang & Olufsen.

Operating voltage

Before connecting the unit to the power source, check that the operational voltage of your unit is the same as the local power supply.

Where purchased	Operating voltage
AEP, WG model	220 V AC, 50/60 Hz
UK model	240 V AC, 50 Hz
US, Canadian model	120 V AC, 60 Hz
E model	120, 220 or 240 V AC adjustable, 50/60 Hz A voltage selector is located on the rear panel. If the selector must be reset, disconnect the AC power cord and set the selector to the appropriate voltage.

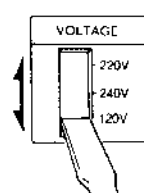

VOLTAGE selector

ATTENTION AU COMPOSANT AYANT RAPPORT À LA SÉCURITÉ

LES COMPOSANTS IDENTIFIÉS PAR UNE MARQUE **▲** SUR LES DIAGRAMMES SCHÉMATIQUES ET LA LISTE DES PIÈCES SONT CRITIQUES POUR LA SÉCURITÉ DE FONCTIONNEMENT. NE REMPLACER CES COMPOSANTS QUE PAR DES PIÈCES SONY DONT LES NUMÉROS SONT DONNÉS DANS CE MANUEL OU DANS LES SUPPLÉMENTS PUBLIÉS PAR SONY.

MODEL IDENTIFICATION

— Specification Label —

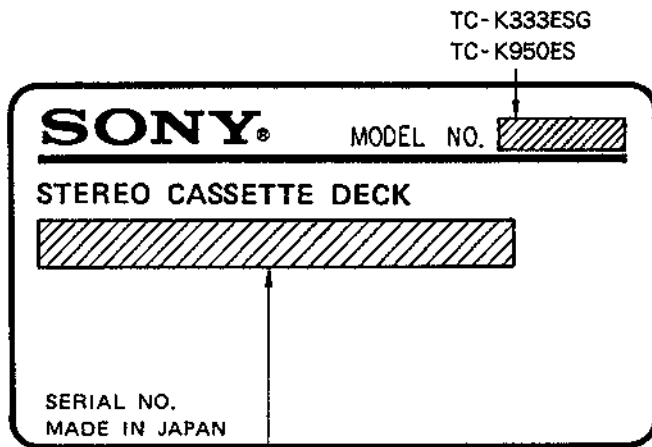

US, Canadian Models: AC: 120V 60Hz 31W
AEP, West Germany

Model: AC: 220V \sim 50/60Hz 31W

UK Model: AC: 240V \sim 50/60Hz 31W

E Model: AC: 120, 220, 240V
 \sim 50/60Hz 31W

SAFETY CHECK-OUT

After correcting the original service problem, perform the following safety check before releasing the set to the customer:

Check the antenna terminals, metal trim, "metallized" knobs, screws, and all other exposed metal parts for AC leakage. Check leakage as described below.

LEAKAGE TEST

The AC leakage from any exposed metal part to earth ground and from all exposed metal parts to any exposed metal part having a return to chassis, must not exceed 0.5 mA (500 microamperes). Leakage current can be measured by any one of three methods.

1. A commercial leakage tester, such as the Simpson 229 or RCA WT-540A. Follow the manufacturers' instructions to use these instruments.
2. A battery-operated AC milliammeter. The Data Precision 245 digital multimeter is suitable for this job.
3. Measuring the voltage drop across a resistor by means of a VOM or battery-operated AC voltmeter. The "limit" indication is 0.75 V, so analog meters must have an accurate low-voltage scale. The Simpson 250 and Sanwa SH-63Trd are examples of a passive VOM that is suitable. Nearly all battery operated digital multimeters that have a 2V AC range are suitable. (See Fig. A)

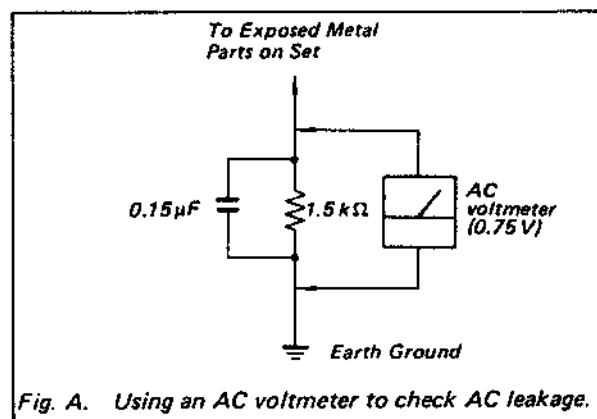

SECTION 1 GENERAL

LOCATION AND FUNCTION OF CONTROLS

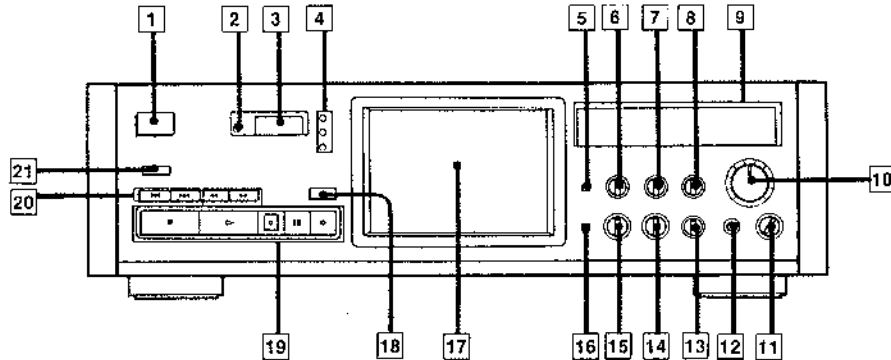

- | | |
|---|--|
| <p>1 POWER switch</p> <p>2 Remote sensor
You can remotely control this cassette deck with:
— A remote commander that has an mark and comes with a Sony amplifier or receiver and which can be used to control a cassette deck.
— An optional Sony remote commander that has an mark.</p> <p>3 LINEAR COUNTER</p> <p>4 RESET button
MEMORY button
DISPLAY MODE button</p> <p>5 Dolby HX PRO button</p> <p>6 DOLBY NR (noise reduction)/ MPX FILTER switch</p> <p>7 MONITOR switch</p> <p>8 INPUT switch</p> <p>9 PEAK PROGRAM METER</p> <p>10 REC (recording) LEVEL</p> <p>11 PHONE (headphones)LEVEL control</p> | <p>12 HEADPHONES jack (stereo headphone jack)</p> <p>13 REC EQ CAL (recording equalization calibration) switch (LOW, NORMAL, HIGH)</p> <p>14 REC (recording) LEVEL control for calibration</p> <p>15 BIAS (bias adjust) control</p> <p>16 CALIBRATION button</p> <p>17 Cassette holder</p> <p>18 OPEN/CLOSE button</p> <p>19 Tape operation buttons and indicators
 (rewind) button
 (stop) button
 (play) button and indicator
 (fast-forward) button
 REC (record) button and indicator
 PAUSE button and indicator
 REC MUTE (record muting) button</p> <p>20 AMS(Automatic Music Sensor) buttons</p> <p>21 TIMER switch</p> |
|---|--|

Remote Commander

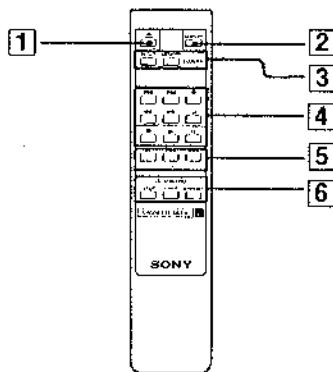

- | | |
|---|---|
| <p>1 (open/close) button
for opening and closing the cassette holder</p> <p>2 DISPLAY button
for selecting the display mode</p> <p>3 Counter buttons
RESET button
for resetting the counter to zero
MEMORY button
for activating and deactivating the Memory function</p> | <p>4 Tape operation buttons
 (AMS*) buttons
for locating selections sequentially
 (leftward fast winding) button
 (rightward fast winding) button
 (forward play) button
 (record) button
 (stop) button
 (pause) button
 (record muting) button</p> <p>5 CD (Compact Disc) buttons (for Sony CD players)
 (pause) button
 (AMS) buttons
for locating selections sequentially</p> <p>6 CD SYNCHRO buttons
for synchronized recording with a Sony CD player (see procedure below)
STOP (synchronized recording stop) button
START (synchronized recording start) button
STANDBY (synchronized recording standby) button</p> |
|---|---|

* AMS is an abbreviation for Automatic Music Sensor.
Procedure for Synchronized Recording with a CD Player

SECTION 2 DISASSEMBLY

NOTE: Follow the disassembly procedure in the numerical order given.

CASSETTE HOLDER

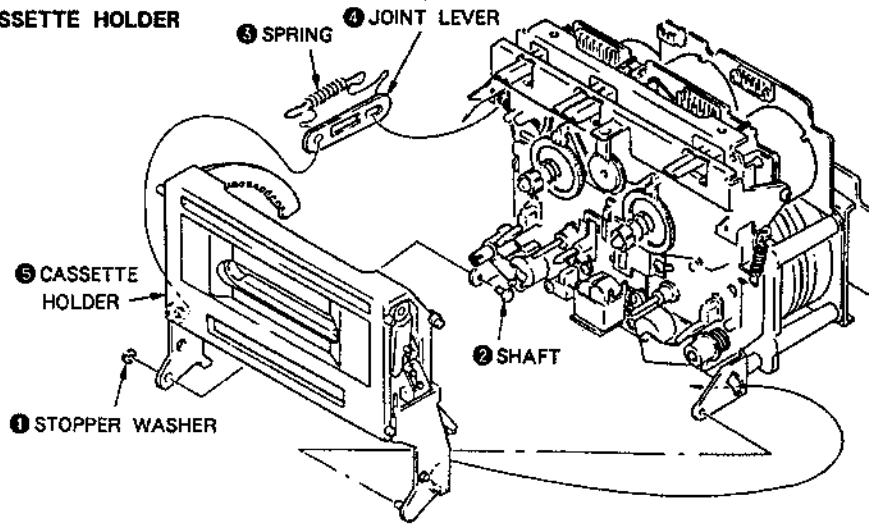

ORNAMENTAL PLATE

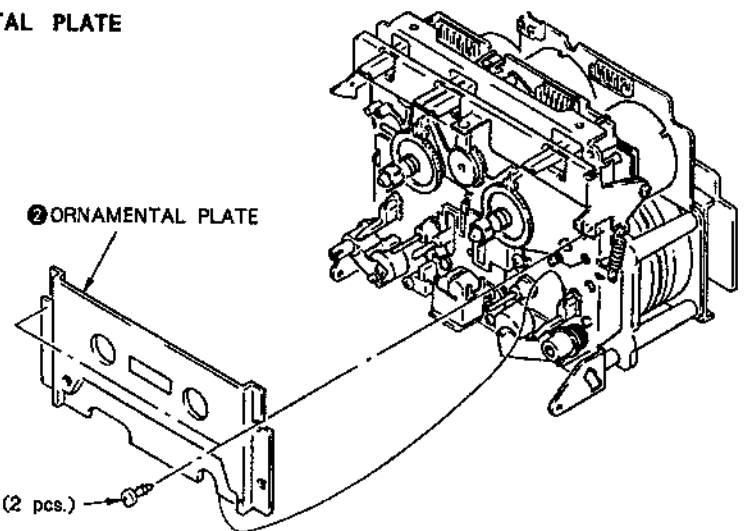

PINCH LEVER/LEVER FR/HEAD

1 - 3: PINCH LEVER S

1, 2: PINCH LEVER T

▲ ▲: LEVER FR

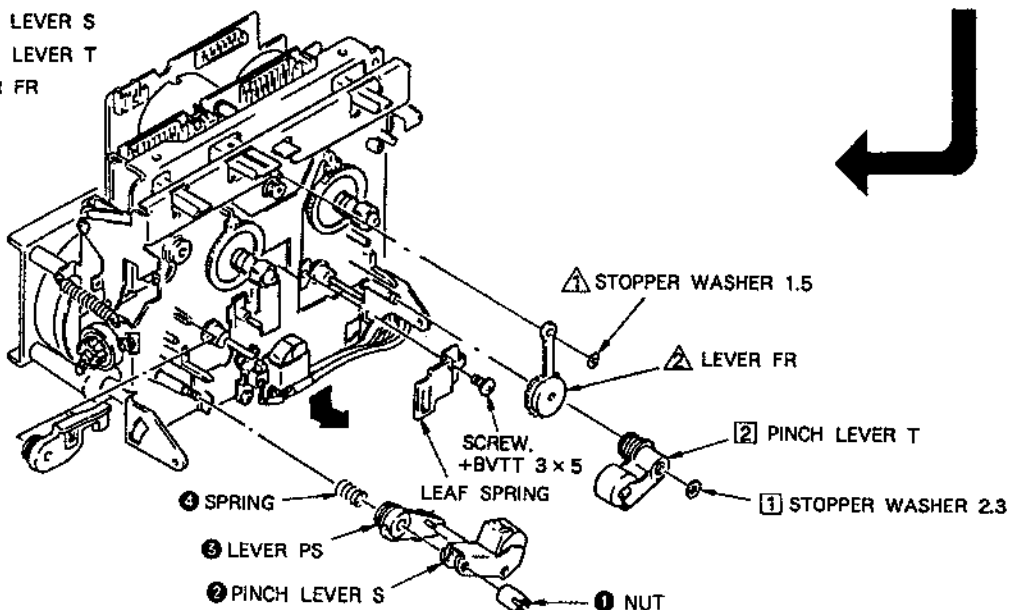

COMPARATOR BOARD/CAPSTAN BOARD/FLYWHEELS/FG BOARD

★ SCREWS, + PS 3 × 6 (2 pcs.)

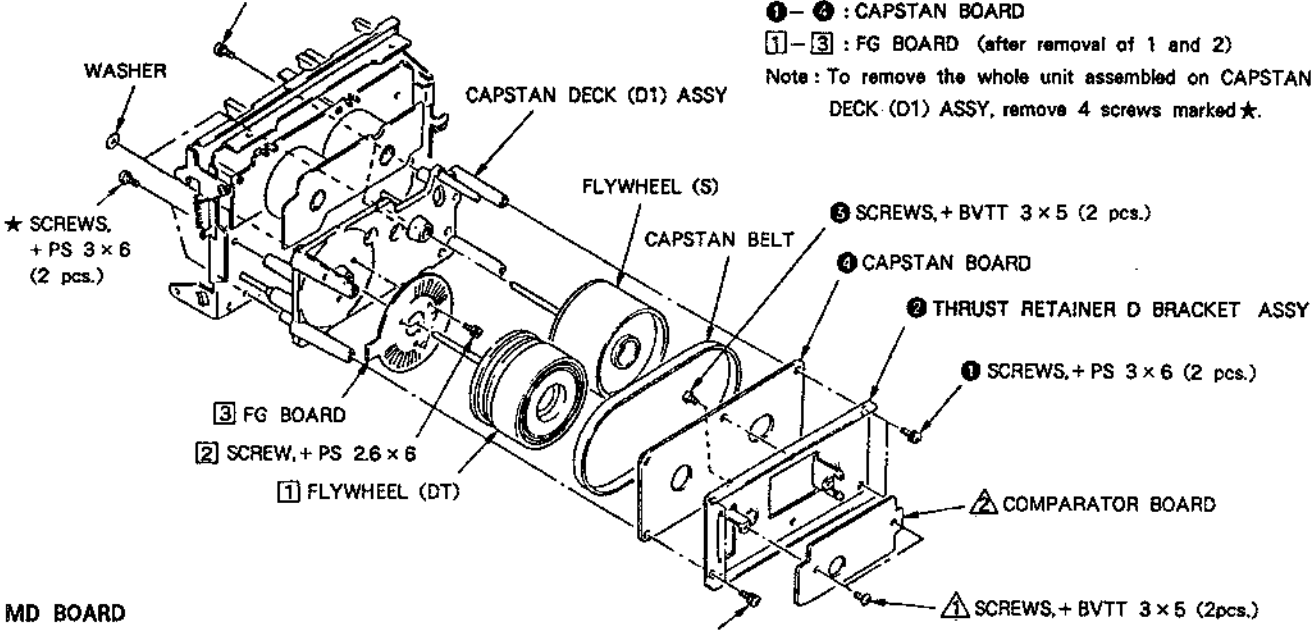

△△△ : COMPARATOR BOARD
 ①-④ : CAPSTAN BOARD
 ①-③ : FG BOARD (after removal of 1 and 2)
 Note: To remove the whole unit assembled on CAPSTAN DECK (D1) ASSY, remove 4 screws marked ★.

MD BOARD

① SCREWS, + BTP 2 × 18 (3 pcs.)

① SCREWS, + PS 3 × 6 (2 pcs.)

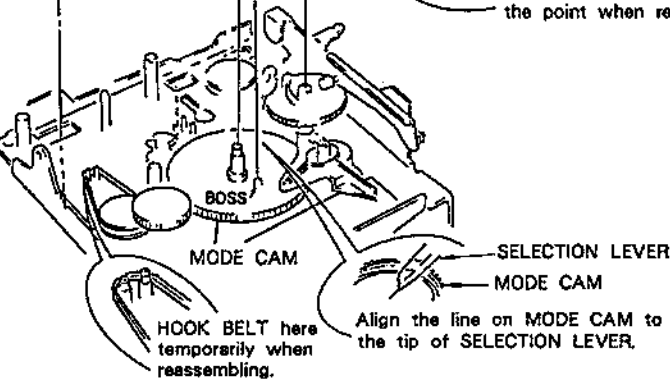
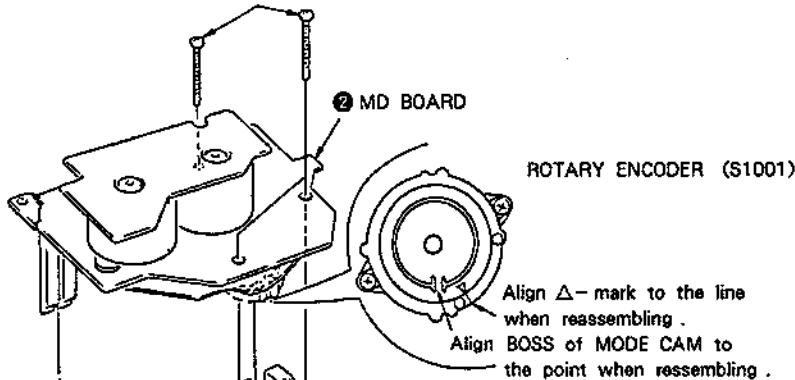

① SCREWS, + B2.6 × 6 (4 pcs.)

REEL MOTOR BOARD

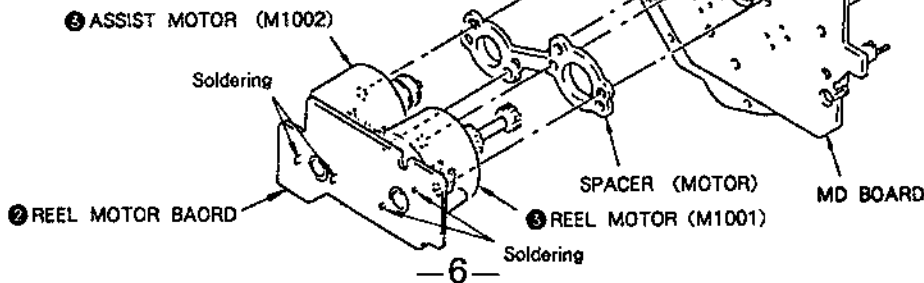

SECTION 3 ADJUSTMENTS

3-1. MECHANICAL ADJUSTMENTS

PRECAUTION

1. Clean the following parts with a denatured-alcohol-moistened swab:

record/playback head	pinch roller
erase head	rubber belts
capstan	idlers
2. Demagnetize the record/playback and erase head with a head demagnetizer.
3. Do not use a magnetized screwdriver for the adjustments.
4. After the adjustments, apply suitable locking compound to the parts adjusted.
5. The adjustments should be performed with the rated power supply voltage unless otherwise noted.

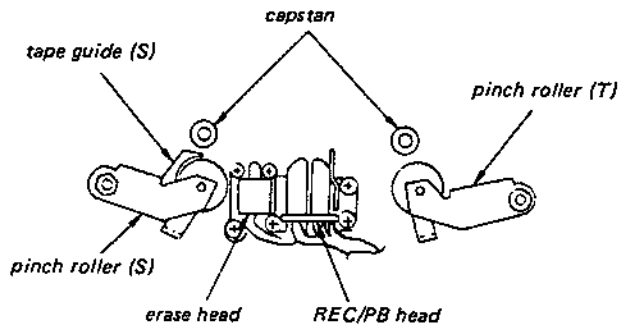

Pinch Roller Pressing Force Measurement

Mode : playback

Hook needle of the tension gauge to the pinch roller shaft and push back pinch roller to detach it from capstan. Then, return it gradually to capstan and read the gauge when the pinch roller begins turning.

Standard Limits :

Tape-up side : 270 - 350g (9.5 - 12oz)

Supply side : 180 - 280g (6.4 - 9.9oz)

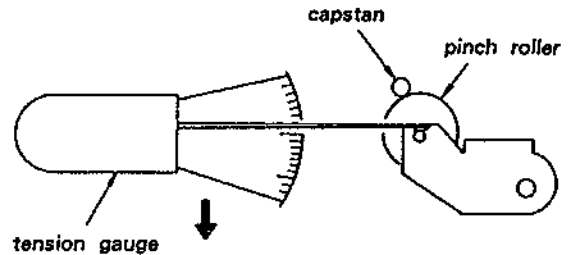

FLYWHEELS T/S THRUST ADJUSTMENT

1. FLYWHEEL T THRUST ADJUSTMENT :

Insert 3mm - thick spacer guage into the clearance between magnet of FLYWHEEL T and CAPSTAN Board, and adjust THRUST SCREW so that thrust play is 0.2 - 0.4mm .

2. FLYWHEELS THRUST ADJUSTMENT :

Tighten THRUST SCREW lightly until the flywheel has no play and then loosen the screw by 1/2 - 3/4 turns.

3. After adjustments, apply locking compounce to the screws.

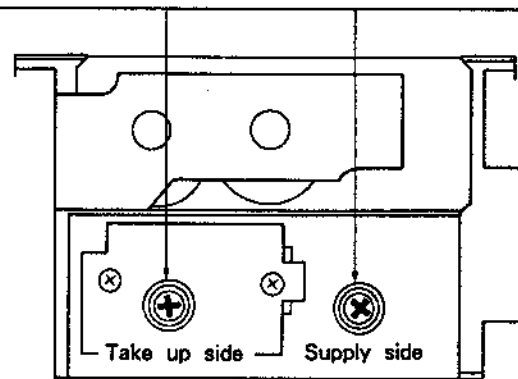
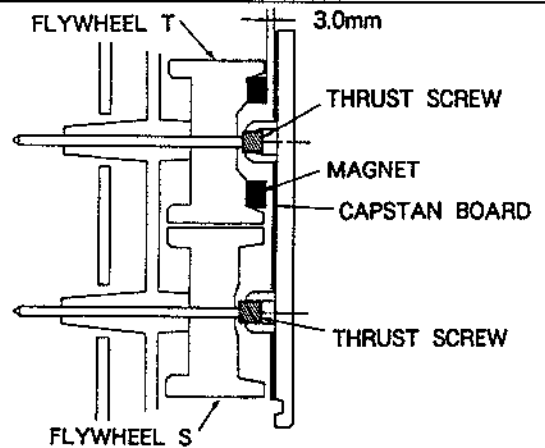

REAR VIEW OF MECHANISM

Tape Path Adjustment

• Refer to Adjustment Position on page 10.

Note: When using the adjustment methods for other than replacement reasons, please do not tamper unnecessarily with the adjustment screws or the erasehead because either the supply pinch roller guide or the record/playback head will be made the standard tape paths. Moreover, when it is necessary to adjust and replace two or more of any of the heads and/or pinch rollers, replace them one by one, completely taking out the first tape path, and then replacing the second one.

Preparation:

1. Mirror cassette CQ009C 8-909-708-01
(or CQ012C 8-909-708-02)

If one does not have this, cut out the sections of a 120-minute cassette shell as indicated below and use that cassette.

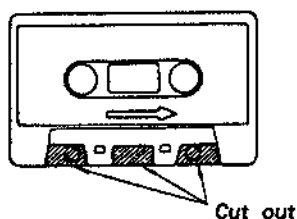

2. Phillips screwdriver (medium-size):
For the head adjustment screws
Blade-type screwdriver (large-size):
For the supply pinch roller adjustment screws
3. Pen light
4. WS-48B (3 kHz, 0 dB)
5. P-4-A100 (10 kHz, -10 dB)

Definition of Terms: The figures are of a record/playback head.

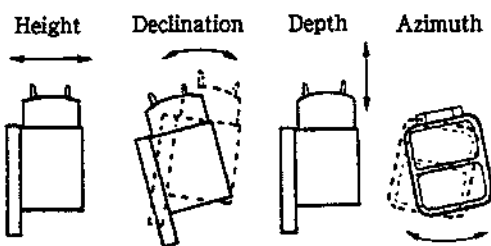

Adjustment Method:

Supply Pinch Roller

Note: Only perform this adjustment when the supply pinch roller is to be replaced.

1. Insert the mirror cassette and put the unit in record/playback mode.
2. Check to see whether the tape is curling at the record/playback head guide or the pinch roller guide.

If it is curling, remove the curl by adjusting the tape curl adjustment screw. Then, check that the tape is running past the middle of the erasehead.

Record/playback Head

Note: Only perform this adjustment when the record/playback head is to be replaced.

1. Insert the mirror cassette and put the unit in record/playback mode.
2. **(Height Adjustment)** Check to see if the tape is curling at the tape guide of the head. If it is curling, tighten screws A, B, and C, respectively by the same angle, moving the head so that it remains at the same angle throughout the procedure. If it curls on the bottom side of the mirror cassette (actually the inner side), tighten all the screws equally; but loosen them if the tape begins to curl on the top side (outer side).

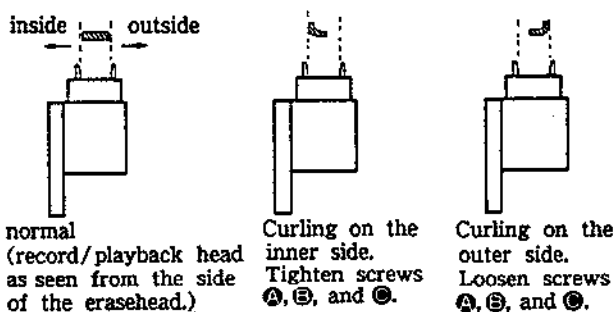

3. **(Declination Adjustment)** While in the record/playback position, set the back tension to 0 (wind the supply reel with something thin like a pencil in a counterclockwise direction) and make sure there is no curling or shifting (shifting up/shifting down) at the guide of the record/playback head.

Because shifting can only occur due to a difference in the width of the tape and that of the tape guides (curling will otherwise occur), it is necessary to pay close attention since it can be easily overlooked. When there is a shift, tighten screws B and C equally and change the declination of the head. If the tape is shifting up, tighten the screws, and if it is shifting down, loosen them.

4. Repeat the adjustments in steps 2 and 3 and fine adjust the height and the declination.

5. (Preliminary Azimuth Adjustment)

After demagnetizing and cleaning the adjustment head, play back WS-48B (3 kHz, 0 dB).

Turn screw ③ so that the reading on the level meter of the unit or that of the level meter connected to LINE OUT is maximized.

If the screw is turned at least half a revolution, repeat the adjustments from step 1.

6. (Tape Path Check) Connect the oscilloscope to LINE OUT and play back P-4-A100 (10 kHz, -10 dB) to display a resurge waveform. After 20 seconds of record/playback (after the tension within the loop has been increased sufficiently), make sure the variation in the resurge is within ± 90 degrees (within ± 45 degrees is desired). If the variation is greater than this, it is because the declination and/or the height adjustment is not perfect. Repeat the adjustments from step 1.

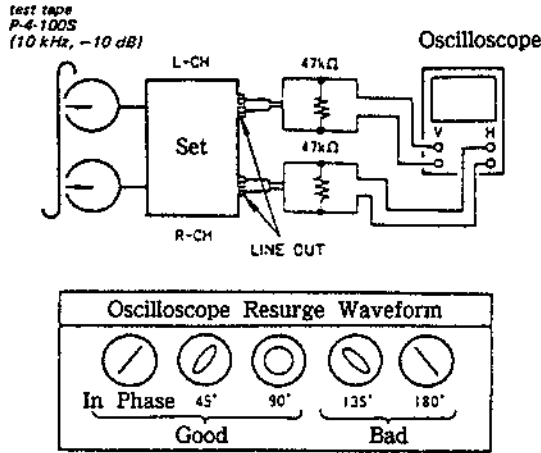

Erasehead

Note: Only perform this adjustment when the erasehead is to be replaced.

1. Insert the mirror cassette and put the unit in record/playback mode.
2. (Azimuth Adjustment) Adjust the azimuth of the erasehead by adjusting screws ③ and ④ so that the tape runs as evenly as possible.

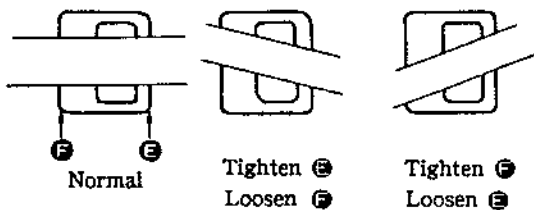

(The erasehead as seen when erasing the mirror cassette.)

3. (Height adjustment) Turn screws ②, ③, and ④ all by the same angle so that the portions of the erasehead visible at top and bottom are nearly of equal width. If the width at the top is greater, tighten the screws; if the width at the bottom is greater, loosen the screws.

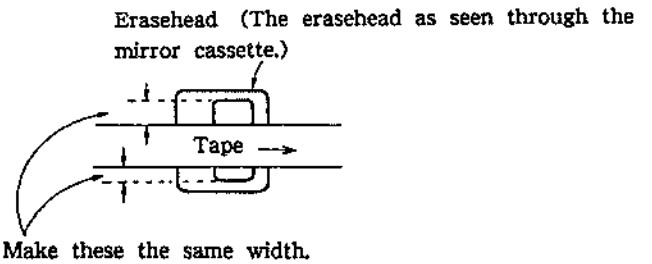

4. (Declination Adjustment) Leaving it in the playback position, put the back tension to 0 and make certain the erasehead part and supply pinch roller guide part do not shift. If there is a shift, turn the screw ⑤ and change the declination. Looking at it using the mirror cassette, if the tape shifts up, tighten the screw, and if it shifts down, loosen the screw.
5. Repeat the adjustments beginning with step 2 and fine adjust the height and declination. And make sure the tape does not curl up on the pinch roller guide or the guide part of the record/playback head.
6. (Depth Adjustment) In order to make the entire head play the tape smoothly, and to make sure the depth of the erasehead is neither too shallow nor too deep, loosen screw ⑥ a bit.

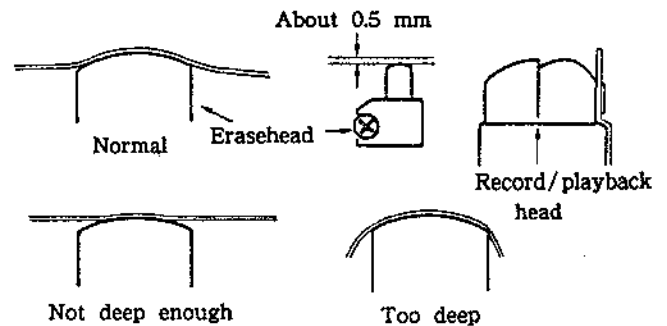

Check

1. Check to make sure that there are no curls or shifts throughout the whole tape path and that the tape runs smoothly.
2. Reapply the locking compound to the adjusted screws. (The locking compound should only be applied to screw ③ after the azimuth has been adjusted.)

Adjustment Position : As seen from the cassette, side (top) and MD as seen head on (bottom).

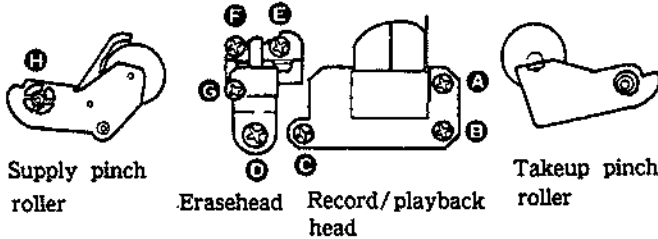
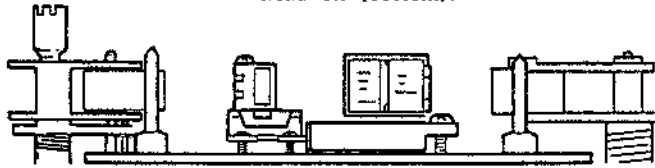

Standard Output Level

Output Terminal	LINE OUT
load impedance	47 kΩ
output level	0.44 V (-5 dB)

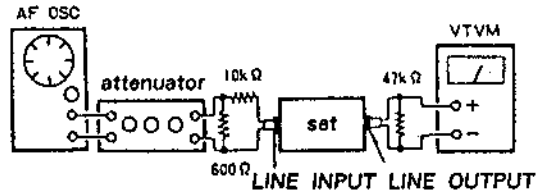

Torque Adjustment and Measurement

1. Load a torque meter cassette CQ-102C and push ► button.
2. Adjust RV801 so that the reading on the torque meter is $40 \pm 3g \cdot cm$ ($0.56 \pm 0.042oz \cdot inch$).
3. After the adjustment, apply suitable locking compound to RV803.

3-2. ELECTRICAL ADJUSTMENTS

Note: The adjustment should be performed in the order given in this service manual.
The adjustments should be performed for both L-CH and R-CH.

- Simultaneous REC/PB Mode:
Input the signals to LINE IN terminal and set to REC mode. Set the monitor switch to TAPE, and monitor the recorded signal from LINE OUT terminal.
- Switch Position:

DOLBY NR.....	OFF
MPX FILTER.....	OFF
TIMER.....	OFF
MONITOR.....	TAPE
HX PRO.....	OFF
CALIBRATION.....	OFF
CD DIRECT.....	OFF
BIAS.....	CENTER CLICK
REC LEVEL.....	CENTER CLICK
BALANCE.....	CENTER CLICK

• Standard Record:
Deliver the standard input signal level to the input jack and set the REC LEVEL control to obtain the standard output signal level.

Standard Input Level

Input Terminal	LINE IN
source impedance	10 kΩ
input level	0.25 V (-10 dB)

Torque	Torque Meter	Reading
FWD	CQ-102C	35 - 45g·cm (0.49 - 0.64oz·inch)
FWD Back tension	CQ-102C	6.5 - 11g·cm (0.09 - 0.15oz·inch)
FF/REW	CQ-201B	70 - 120g·cm (0.97 - 1.67oz·inch)

Record/Playback Head Azimuth Adjustment

Procedure :

1. Mode : playback

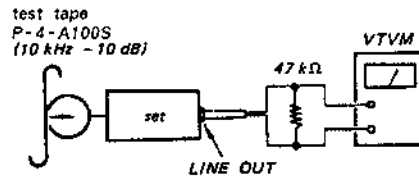

2. Turn the adjustment screw for the maximum output levels. If these levels do not match, turn the adjustment screw until both of output levels match together within 0.5dB.

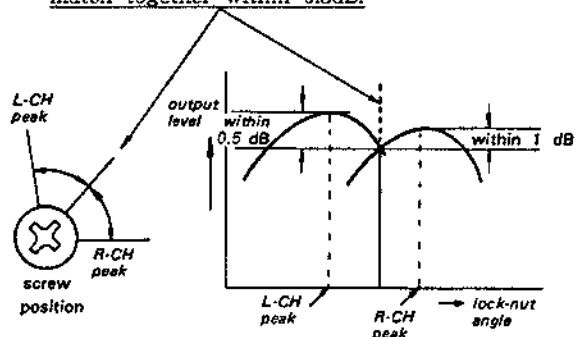

3. Phase check

By the means of 6. Tape Path check on page 9 confirm that phase difference is proper.

4. After the adjustment, lock the adjustment screw with locking compound.

Adjustment Location :

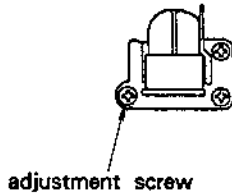

Tape Speed/WOW Check

Procedure:

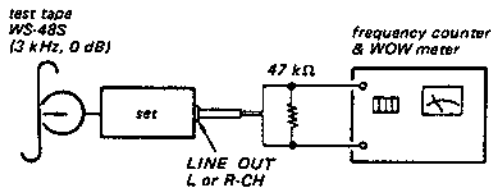

1. Measure the output frequency and the WOW value while playing back the tape top of the test tape.
2. Turn over the test tape, measure the output frequency and the WOW value, and check the difference from the values of the step 1.

Adjustment Limits :

TAPE SPEED deviation:	within 2,990 to 3,010 Hz
TAPE SPEED fluctuating width:	within 2,990 to 3,010 Hz
WOW (WRMS):	0.037% or less

Playback Level Adjustment

Procedure:

Mode: playback

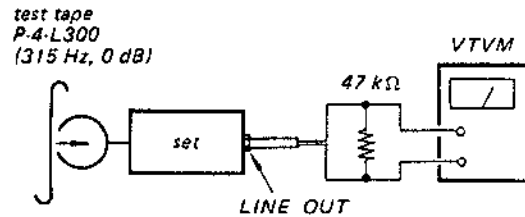

Adjust RV101 (L-CH) and RV201 (R-CH) to obtain the specified LINE OUT level.

Adjustment Limits :

LINE OUT level: 0.42 to 0.46 V
(-5.3 to -4.7 dB)

Level difference between channels:
less than 0.5 dB

Check that the LINE OUT level does not change in playback mode while changing the mode from playback to stop several times.

MPX FILTER Check

Setting : DOLBY switch : OFF
MPX FILTER switch : OFF

Procedure :

1. Mode: stop

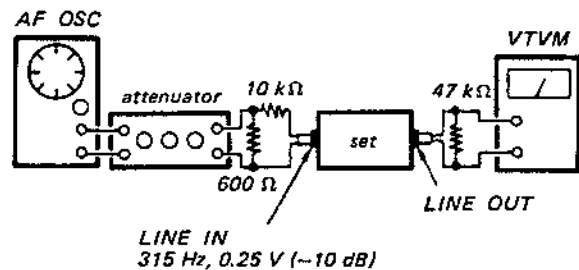

2. Apply 315Hz, 0.25V (-10dB) signal and adjust REC LEVEL (RV501) control so that the LINE OUT level is 0.44V (-5dB).
3. Set DOLBY switch to B or C and MPX FILTER switch ON. Confirm that the LINE OUT level is 0.39V to 0.49V (-5dB ± 1dB).
4. Apply 19kHz 0.25V (-10dB) signal and confirm that the LINE OUT level is 0.013V (-35dB) or less.

Adjustment Limits :

LINE OUT level	
315Hz	0.39V - 0.49V (-5dB ± 1dB)
19kHz	0.014V (-35dB)

Bias OSC Frequency Adjustment

Procedure :

1. Record mode

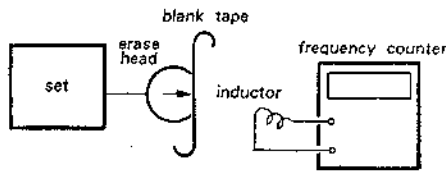

1. Connect the frequency counter to the inductor which functions at 10 mH. (When the inductor is a closed magnetic circuit, redesign the inductor to be an open magnetic circuit.)
2. Remove the cassette lid, insert the cassette, and put the unit into REC mode.
3. Move the inductor from the side in close to the erase head to check the value of the bias.
4. Adjust CP501 so that the reading on the frequency counter is 105kHz \pm 1kHz.

CrO₂ Bias and Record Level Adjustment

Note : This adjustment should be made before Record Bias Adjustment.

Setting:

REC LEVEL knob: standard record position
(See page 10.)

HX PRO switch : ON

Procedure:

1. Mode: simultaneous REC/PB

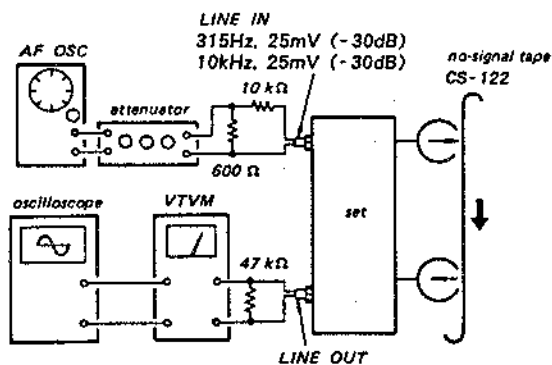

2. Adjust RV105 (L-CH) and RV205 (R-CH) so that the playback output level of 10kHz signal is 0.3dB to 0.3dB with respect to that of 315Hz. . . . Record Bias Adjustment.
3. Adjust RV102 (L-CH) and RV202 (R-CH) so that the playback output level of 315Hz is -25.3dB to -24.7dB. . . . Record Level Adjustment.

Metal Bias Adjustment

Setting :

REC LEVEL Knob : standard record position
(See page 10.)

Procedure :

1. Mode : simultaneous REC/PB

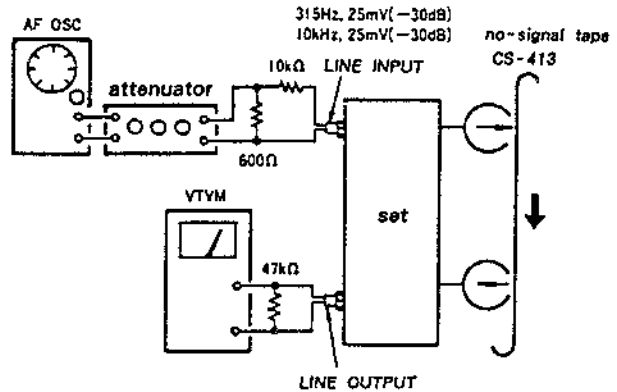

2. Only when the level difference of 10kHz playback output between L-ch and R-ch is 1dB or more short or open EQ-tap for TYPE-IV (on the conductor side of REC board).
3. Adjust RV510 so that the playback output level of 10kHz in R-CH is 0.5dB to -0.5dB with respect to that of 315Hz.

Normal Bias Adjustment

Setting:

REC LEVEL knob: standard record position
(See page 10.)

Procedure:

1. Mode: simultaneous REC/PB

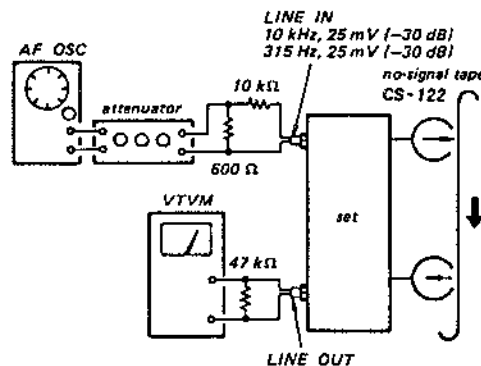

2. Only when the level difference of 10kHz playback output between L-ch and R-ch is 1dB or more short or open EQ-tap for TYPE-I (on the conductor side of REC board).
3. Adjust RV509 so that the output level of 10kHz is 0.5dB to -0.5dB with respect to that of 315Hz.

Meter Level Adjustment

Setting :

REC LEVEL Knob : standard record position
(See page 10.)

MONITOR : SOURCE

Procedure :

1. Stop mode

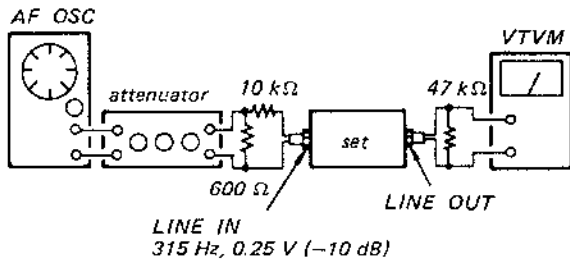

2. Adjust the REC LEVEL (RV501) control so that the LINE OUT level is 0.44V (-5 dB). In this time adjust RV103 (L-CH) and RV203 (R-CH) so that the 0VU (-4 dB) segments of the meter light-up.
3. Adjust the REC LEVEL (RV501) control so that the LINE OUT level is 1.9V (8 dB). In this time, make sure that all the segments of the meter light-up.

Calibration OSC and Calibration Meter Adjustment

Setting : CALBRATION switch : ON

Procedure (OSC OUT LEVEL) :

1. Mode : record (no-signal (LINE INPUT))

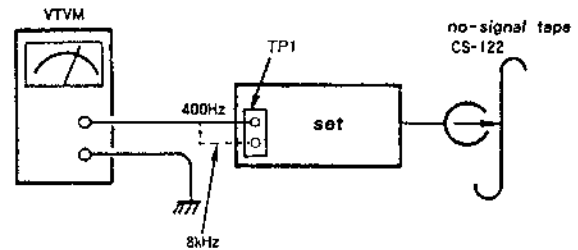

2. Adjust RV508 for 400Hz and RV507 for 8kHz to obtain oscillation level within $10 \pm 0.5dB$ respectively.

Procedure (CAL METER ADJ) :

1. Put the set in record mode and adjust RV104 (HIGH) so that HIGH FREQ segments in the CAL LEVEL meter light thoroughly up to 0 VU as shown in the figure below. Segment (a) may flicker.
2. Preset RV204 (LOW) so that segment (a) in LOW FREQ CAL LEVEL meter lights. Then adjust RV204 to the point where segment (a) goes out.

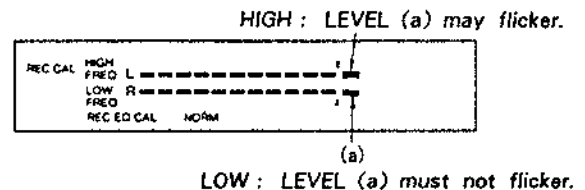

Adjustment Parts Location :

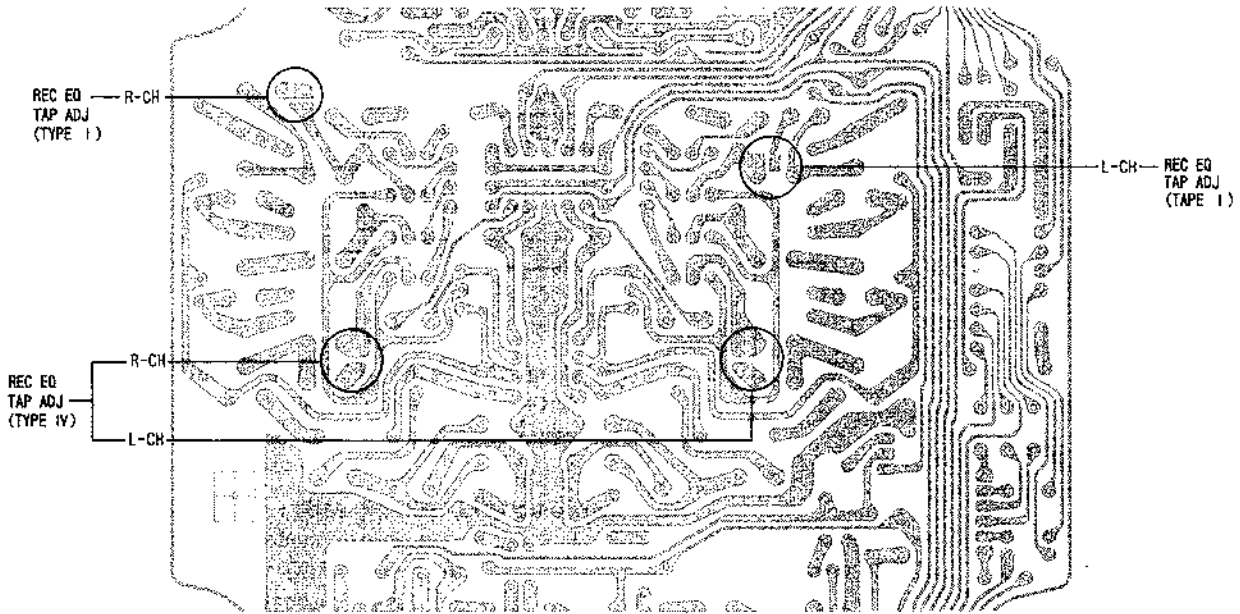

REC BOARD
- CONDUCTOR SIDE -

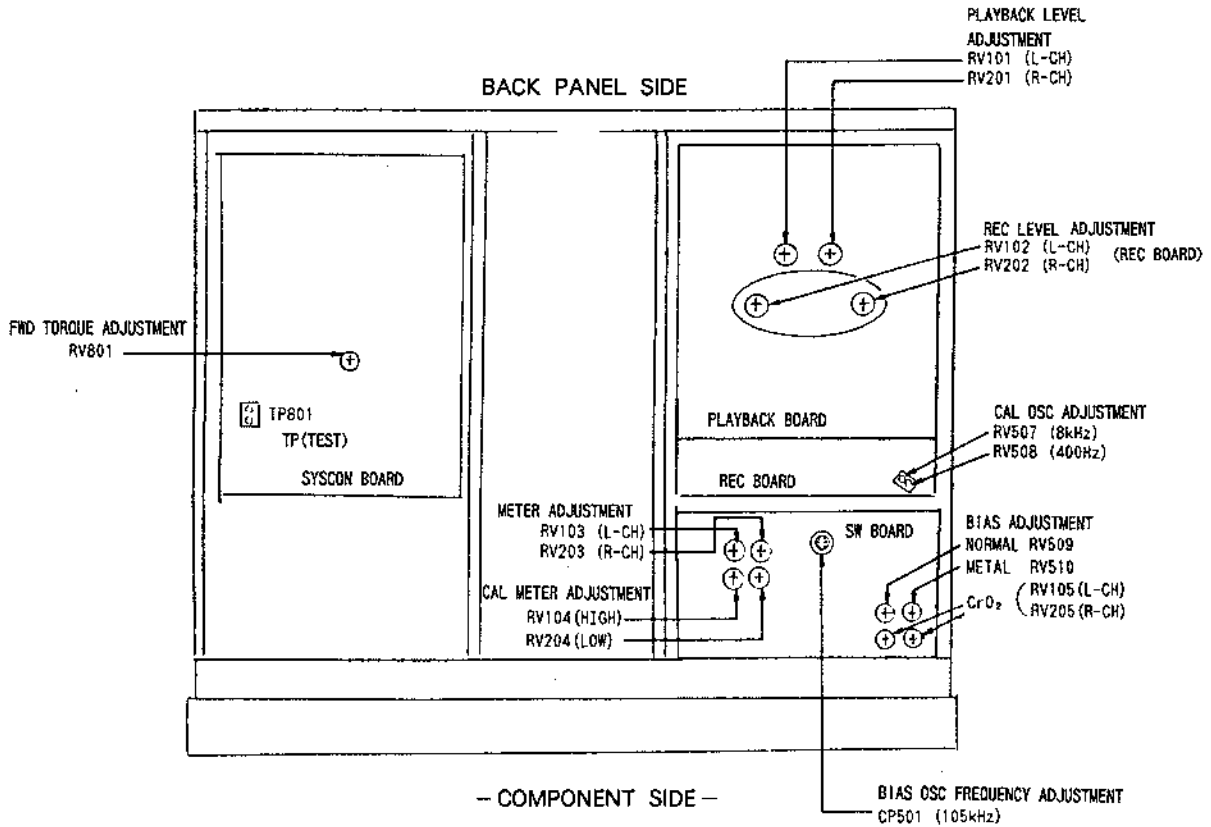

- COMPONENT SIDE -

SECTION 4 DIAGRAMS

4-1-1. IC BLOCK DIAGRAMS

IC503, 505 CX20188

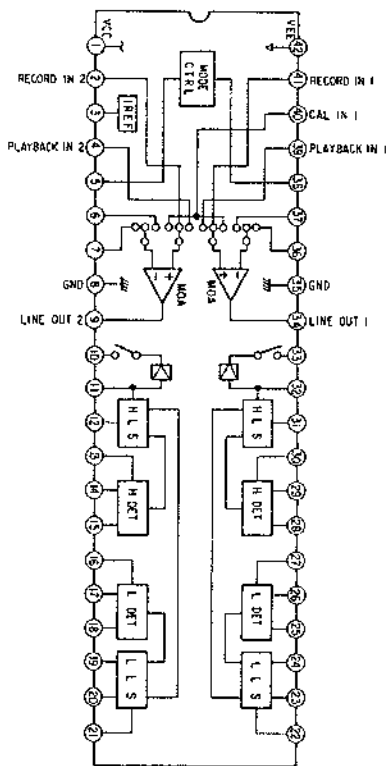

4-2-1. IC503, 505 (CX20188) PIN FUNCTIONS

Pin No.	Pin name	Description
1.	Vcc	Positive power supply terminal.
2, 41.	REC IN	Recording input terminal.
3.	I REF	Reference current input terminal.
4, 39.	PB IN	Playback input terminal.
5.	CAL/REC/PB	Calibration/recording/playback select terminal
6, 37.	PB FB	Playback feedback terminal.
7, 36.	REC FB	Recording feedback terminal.
8, 35.	GND	GND terminal.
9, 34.	LINE OUT	Line output (decode output) terminal.
10, 33.	SSK	Spectral skewing switch terminal.
11, 32.	VF IN	Encode circuit input terminal.
12, 31.	HPF H	HLS high-pass filter terminal.
13, 30.	TCH 2	HLS detector time constant terminal 2.
14, 29.	TCH 1	HLS detector time constant terminal 1.
15, 28.	WT H	HLS encoder error reduction terminal.
16, 27.	TCL 2	LLS detector time constant terminal 2.
17, 26.	TCL 1	LLS detector time constant terminal 1.
18, 25.	WT L	LLS encoder error reduction terminal.
19, 24.	RPF L	LLS high-pass filter terminal.
20, 23.	ANT S	Anti-saturation terminal.
21, 22.	REC OUT	Recording output (encode output) terminal.
38.	OFF/B/C	Dolby NR off/B type/C type select terminal.
40.	CAL IN	Calibration input terminal.
42.	Vee	Negative power supply terminal.

IC512 BA6138

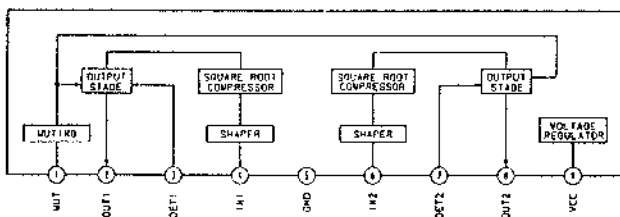

IC517 μPC1297CA

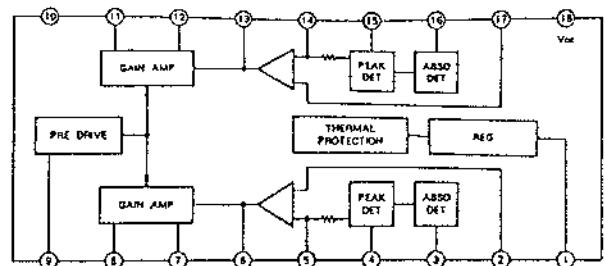

IC803 BA6219B

IC804 LB1641

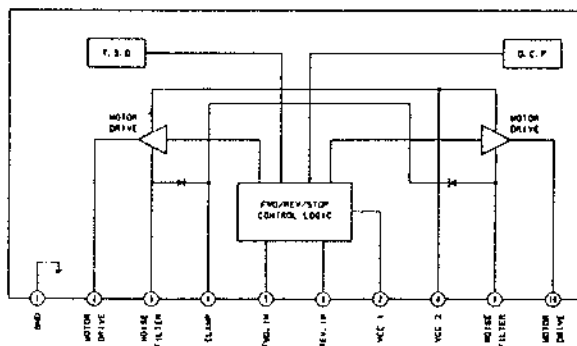

IC806 MSL9512RS

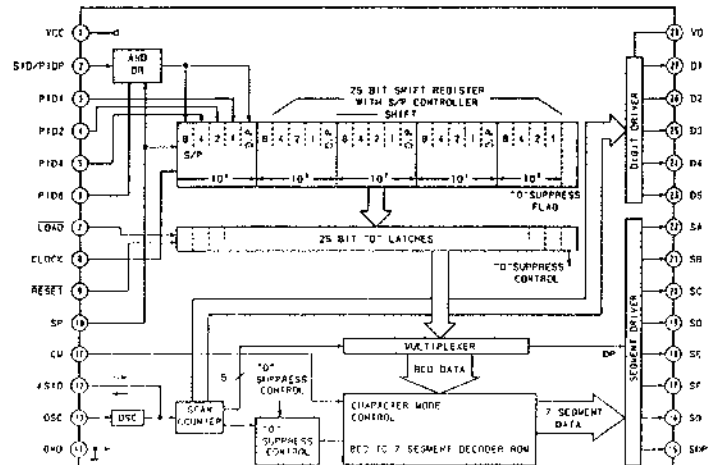

4-2-2. IC801 (M50964-220SP) PIN FUNCTIONS

Pin No.	Pin name	I/O	Description
1.	VCC		Power supply: +5V.
2.	AVss		Analog GND.
3.	Vref	I	A/D port reference voltage input.
4.	DA		Not used for this model.
5.	PWM		Not used for this model.
6.	P. OFF		Not used for this model. Connected to GND.
7.	LED	O	PAUSE LED output.
8.	LED	O	REC LED output.
9.	LED	O	PLAY LED output.
10.	AD1	I	Key input. 0V=▲, 1V=■, 2V=◀, 3V=▶, 4V=●.
11.	AD2	I	Key input. 0V=▶, 1V=■, 2V=◀, 3V=▶, 4V=○.
12.	AMS SIG	I	AMS signal input. No song detected = Low. Song detected = High.
13.	AD4	I	Key input. 2V = DISPLAY. 3V = MONITOR.
14.	CODE	I	Remote control category select switch.
15.	ALB		Connected to 5V.
16.	φR	I	Take-up reel base sensor input.
17.	φL	I	Supply reel base sensor input.
18.	C RESET		Model select input. Connected to GND.
19.	C MEMORY		Model select input. Connected to GND.
20.	COO		Not used for this model.
21.	POWER IN	I	Power on and off detection.
22.	SIRW	I	SIRCS phase input.
23.	SIRE	I	SIRCS reverse phase input.
24.	T-REC	I	Timer REC switch input.
25.	T-PLAY	I	Timer PLAY switch input.
26.	TNT	I	External interruption input. Interruption process is performed when the power is on or off.
27.	Vss		GND.
28.	RESET	I	Reset input.
29.	XIN	I	Clock input (4 MHz).
30.	XOUT	O	Clock output (4 MHz).
31.	φout		Not used for this model.
32.	Vss		GND.
33.	C1	I	Rotary encoder input to detect the position of the head base of the mechanical block.
34.	C2	I	Rotary encoder input to detect the position of the head base of the mechanical block.
35.	C3	I	Rotary encoder input to detect the position of the head base of the mechanical block.
36.	C4	I	Rotary encoder input to detect the position of the head base of the mechanical block.
37.	OPEN SW	I	OPEN switch input of the mechanical block.
38.	CLOSE SW	I	CLOSE switch input of the mechanical block.
39.	DOOR SW	I	DOOR switch input of the mechanical block.
40.	REC SW	I	REC switch input of the mechanical block.
41.	M PLAY	O	Reel motor rotates at PLAY speed.
42.	M FAST	O	Reel motor rotates at FF/REW speed.
43.	M FWD	O	Reel motor rotates.
44.	M REV	O	Reel motor rotates in reverse.
45.	CAM DOWN	O	Head base DOWN output of the mechanical block
46.	CAM UP	O	Head base UP output of the mechanical block
47.	C OFF	O	Counter light-off output
48.	M OFF	O	Meter light-off output
49.	BIAS	O	Bias oscillation on and off control
50.	R MUTE	O	REC MUTE.
51.	M MUTE		Not used for this model.
52.	T MUTE	O	Tape MUTE. Goes to low when the tape is being played.
53.	S MUTE	O	Source MUTE. Goes to low three seconds after the power is on.
54.	AMS	O	AMS switch output. Goes to low when AMS is being used.
55.	MONITOR		Not used for this model. Connected to GND.
56.	HALF		Not used for this model. Connected to GND.
57.	DAT3	O	Outputs parallel data for the counter display.
58.	DAT2	O	Outputs parallel data for the counter display.
59.	DAT1	O	Outputs parallel data for the counter display.
60.	DAT0	O	Outputs parallel data for the counter display.
61.	DATD	O	Outputs parallel data for the counter display.
62.	CLK	O	Clock output to transmit the parallel data.
63.	LATCH	O	Output for latching the transmitted data.
64.	CAL IN	I	CAL switch input.

4-1-2. IC BLOCK DIAGRAMS

IC514 MSL9359RS

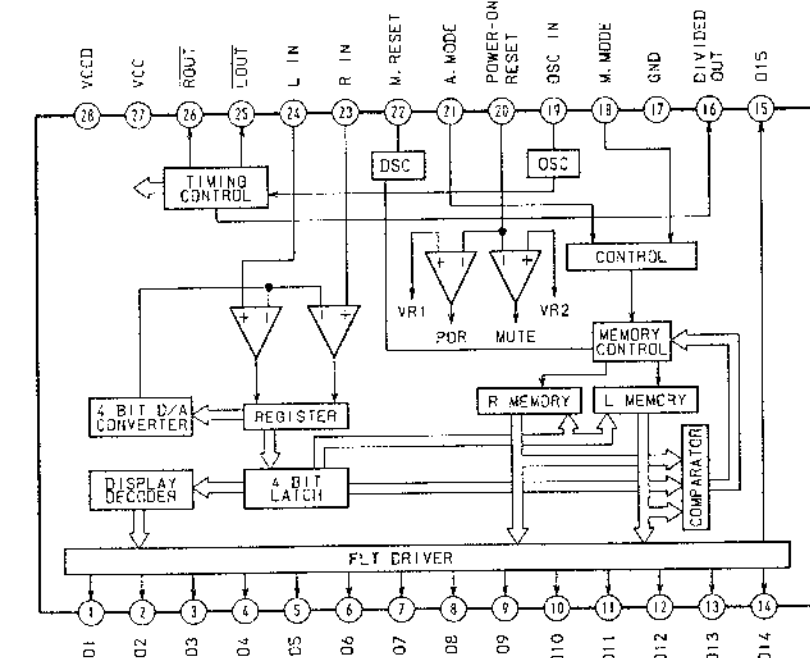

IC902 CX20174

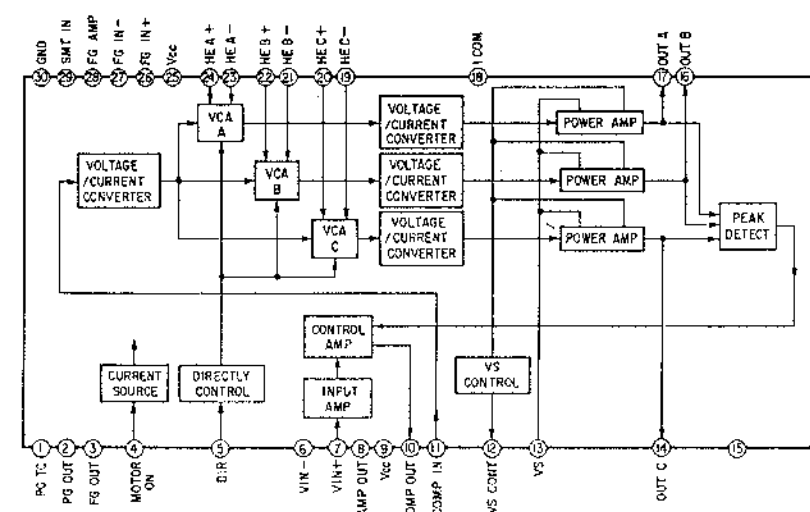

IC952 TC9142P

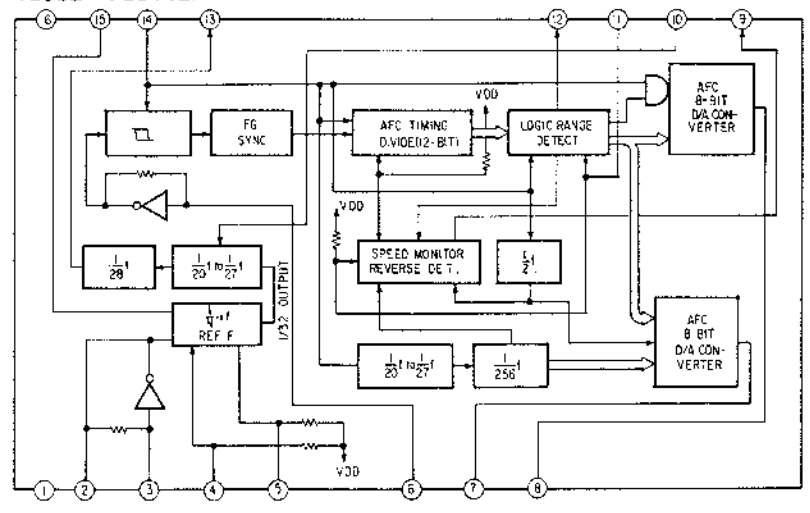

4-3. BLOCK DIAGRAM

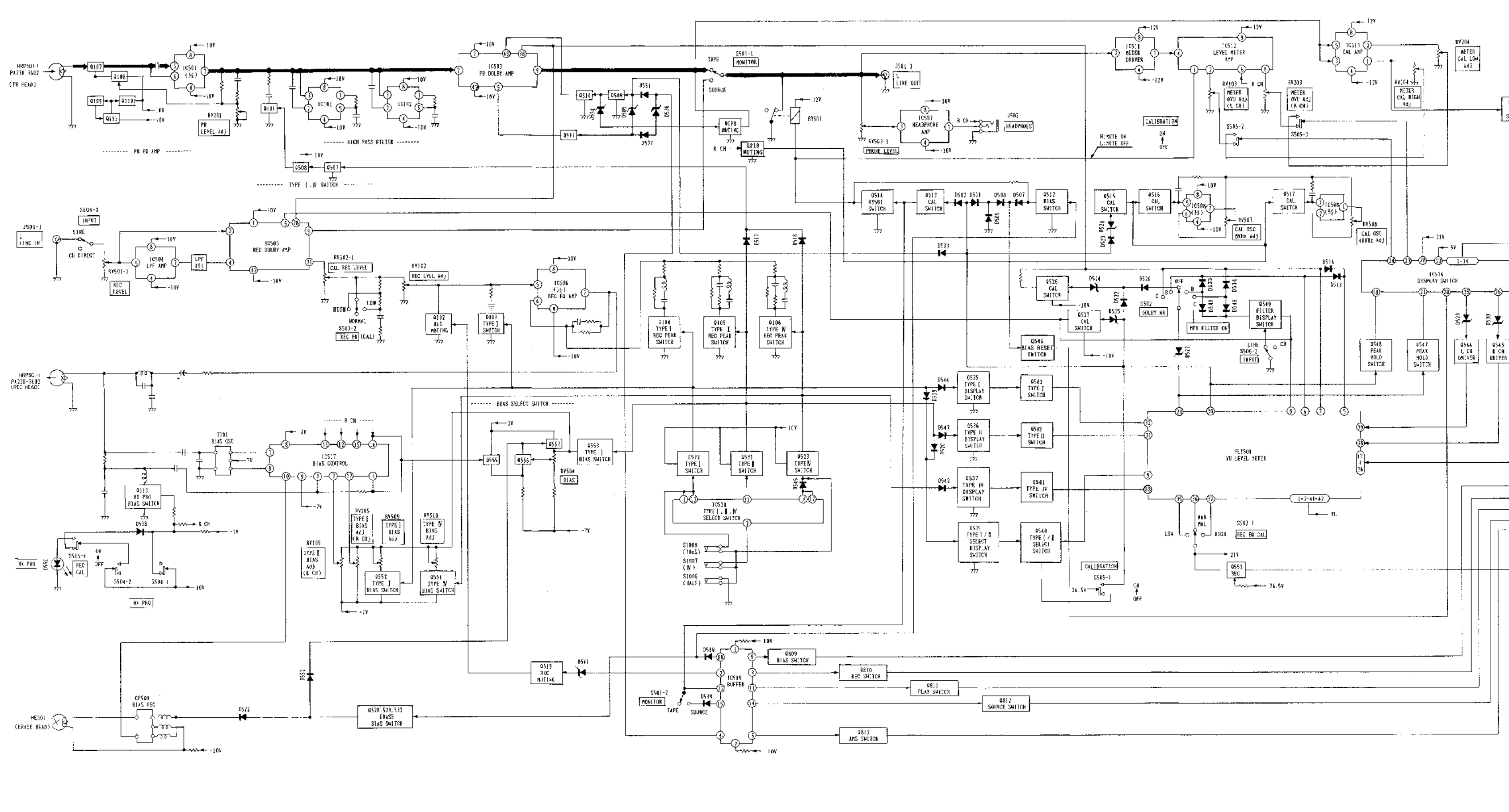

4-4. SEMICONDUCTOR LEAD LAYOUTS

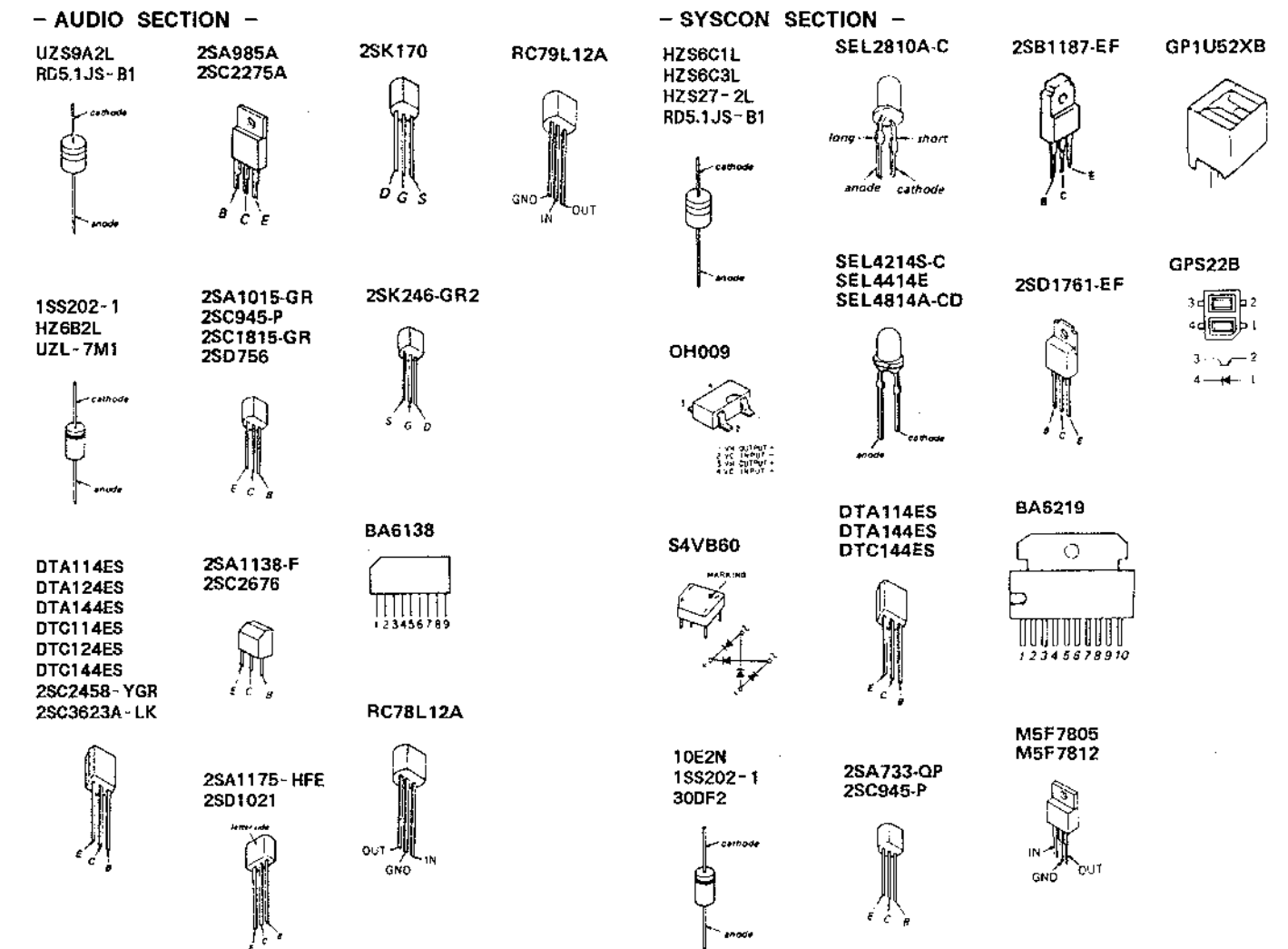

4-5. CIRCUIT BOARDS LOCATION

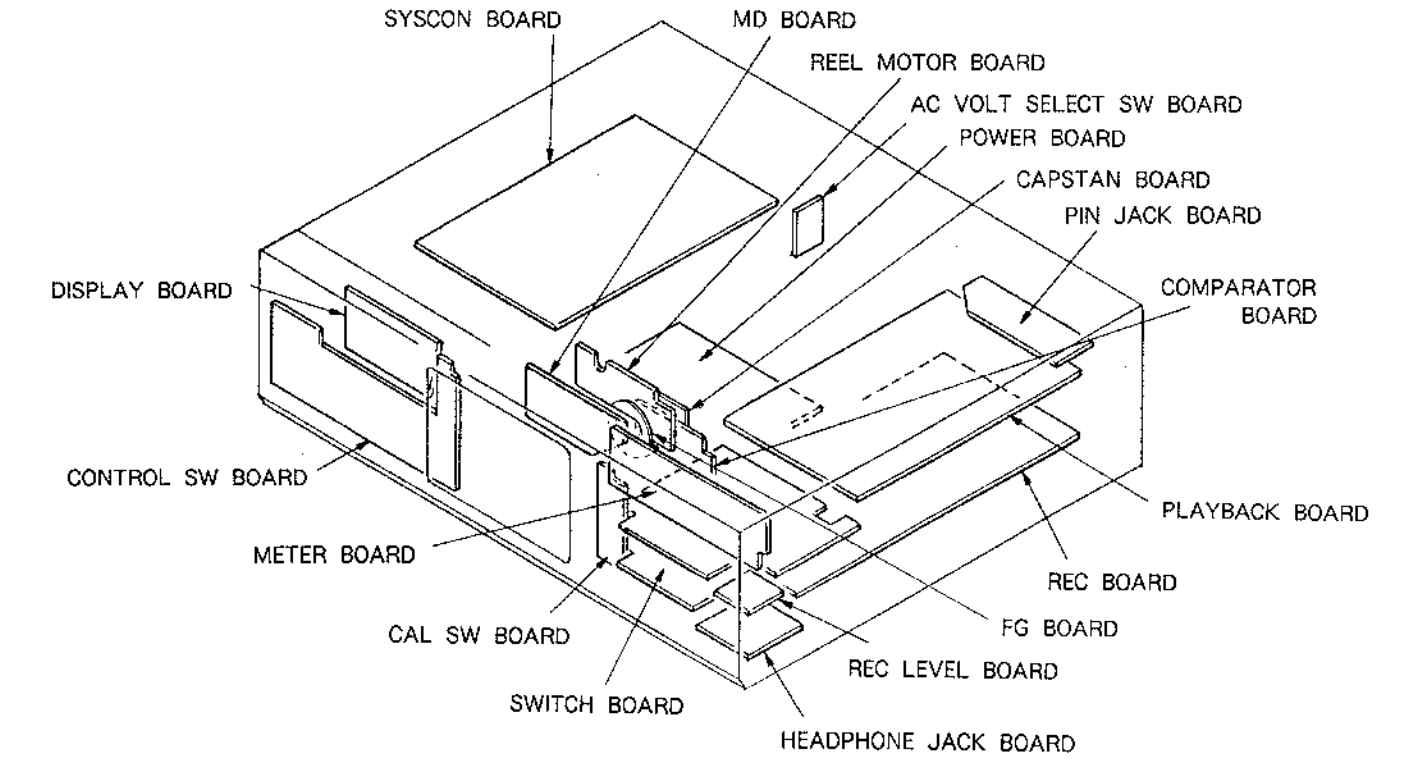

4-6. PRINTED WIRING BOARDS - AUDIO SECTION -

• Semiconductor Location

Ref. No.	Location	Ref. No.	Location	Ref. No.	Location	Ref. No.	Location	Ref. No.	Location
D101	D-18	D532	I-13	IC505	I-6	Q205	J-9	Q525	E-5
D201	D-16	D533	B-19	IC506	J-9	Q206	J-9	Q526	H-5
D503	C-5	D534	A-19	IC507	C-3	Q207	E-7	Q527	H-5
D504	D-5	D535		IC508	K-13	Q208	E-7	Q528	H-14
D505	B-10	D536	A-10	IC509	H-4	Q209	E-7	Q529	I-14
D506	C-17	D537	B-10	IC510	G-4	Q210	E-6	Q530	D-17
D507	G-12	D538	B-14	IC511	D-17	Q211	E-7	Q531	H-7
D508	G-12	D539	G-10	IC512	C-16	Q212	B-11	Q532	I-14
D509	G-12	D540	G-11	IC513	D-17	Q218	J-11	Q533	H-7
D510	G-11	D541	G-6	IC514	C-23	Q501	C-5	Q535	E-16
D511	G-13	D542	E-16	IC517	I-11	Q502	D-5	Q536	E-16
D512	G-13	D543	E-16	IC519	G-9	Q503	B-5	Q537	D-16
D513	A-17	D544	E-16	IC520	H-6	Q504	E-5	Q539	A-17
D514	H-5	D545	G-6			Q505	A-6	Q540	B-18
D515	H-5	D546	G-8	Q101	B-8	Q506	F-6	Q541	E-23
D516	B-17	D547	G-8	Q102	I-7	Q507	A-11	Q542	E-23
D517	G-7	D548	B-19	Q103	I-8	Q508	B-11	Q543	D-23
D518	G-7	D549	A-18	Q104	I-8	Q509	A-11	Q544	E-23
D519	G-6	D550	A-14	Q105	I-9	Q510	D-10	Q545	E-23
D520	E-16	D551	A-10	Q106	I-9	Q511	B-10	Q546	D-23
D521	H-13	D552	I-13	Q107	B-7	Q512	G-12	Q547	D-23
D522	I-14	D553	H-5	Q108	B-7	Q513	G-13	Q548	D-23
D523	J-15	D554	B-12	Q109	B-7	Q514	G-13	Q549	A-17
D524	J-14			Q110	B-6	Q515	J-14	Q551	B-16
D525	B-18	IC101	B-9	Q111	B-7	Q516	K-13	Q552	E-17
D526	A-19	IC102	B-9	Q113	H-10	Q517	K-13	Q553	H-12
D527	B-17	IC201	E-9	Q118	C-17	Q519	G-6	Q554	E-17
D528	A-16	IC202	E-9	Q201	E-8	Q521	H-13	Q555	I-12
D529	E-23	IC501	D-8	Q202	J-8	Q522	I-13	Q556	I-13
D530	E-23	IC503	C-11	Q203	J-8	Q523	H-8	Q557	I-13
D531	C-23	IC504	J-4	Q204	J-9	Q524	B-5		

Note on Mounting Diagram:
 ● ○ — parts extracted from the component side.

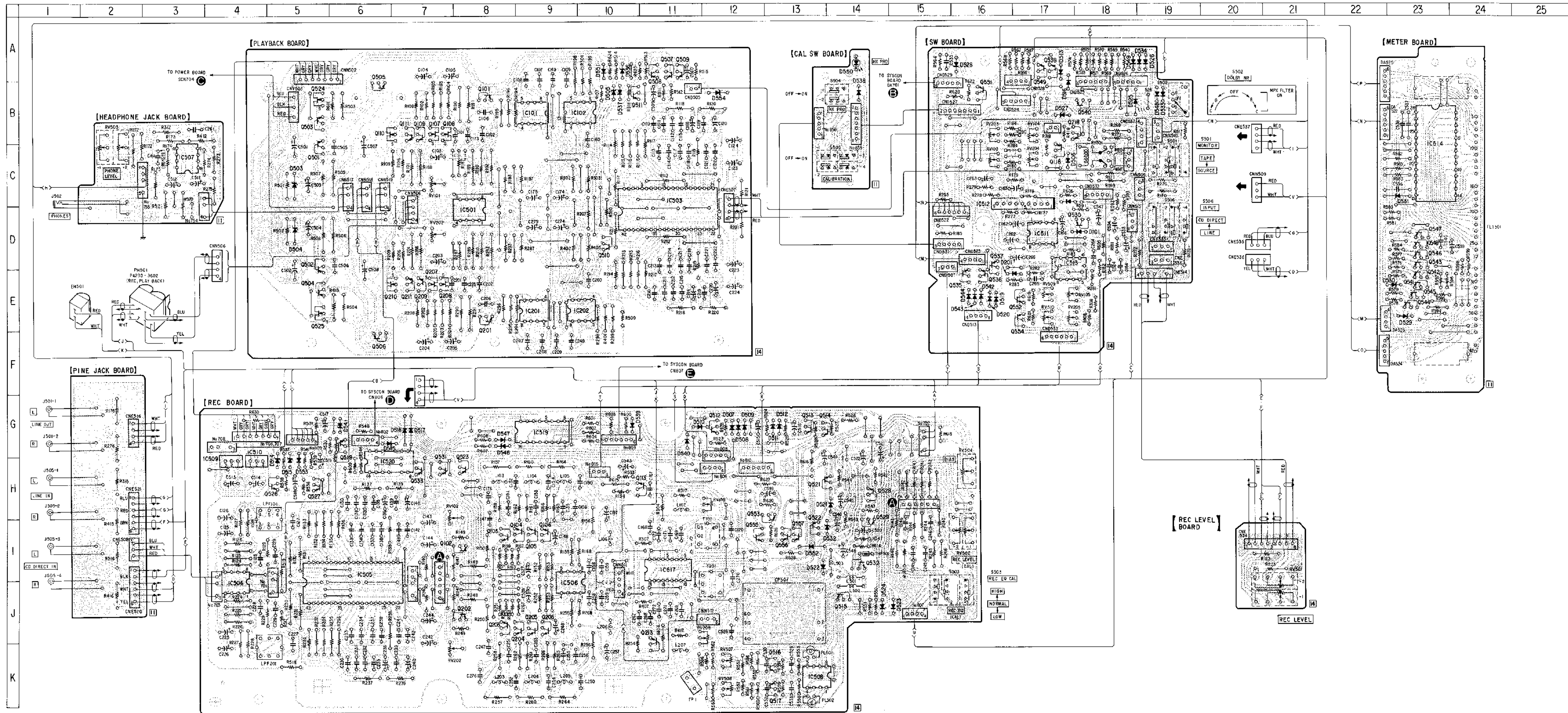

4-7. SCHEMATIC DIAGRAM - AUDIO SECTION -

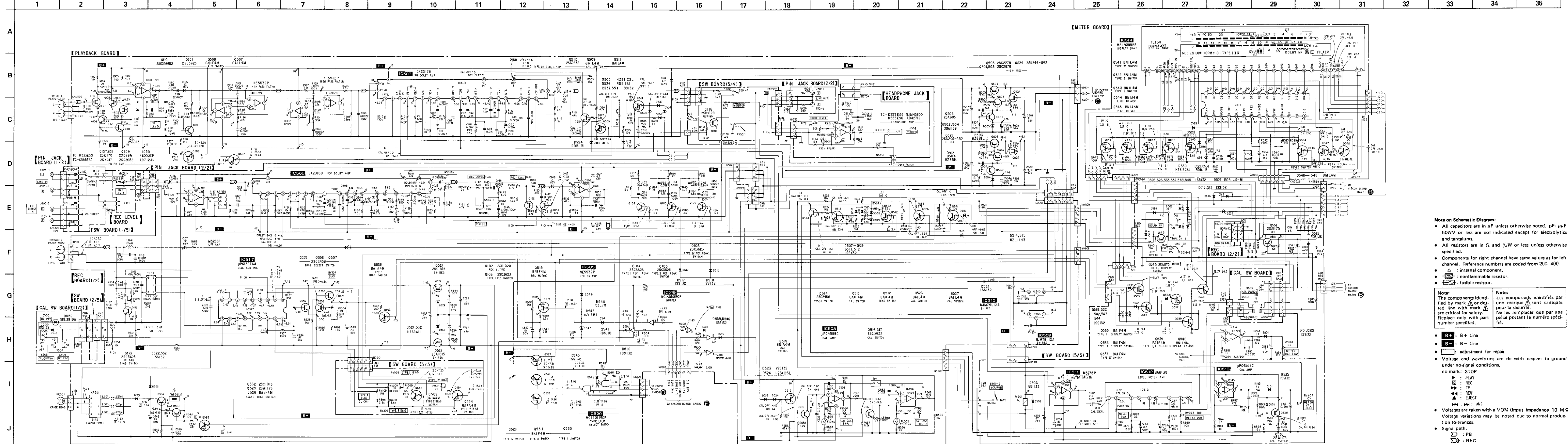

Note on Schematic Diagram:

- All capacitors are in μF unless otherwise noted. pF : μF 50WV or less are not indicated except for electrolytics and tantalums.
- All resistors are in Ω and $1/4\text{W}$ or less unless otherwise specified.
- Components for right channel have same values as for left channel. Reference numbers are coded from 200, 400.
- \triangle : internal component.
- \square : nonflammable resistor.
- $\text{---}/\text{---}$: fusible resistor.

Notes:

The components identified by mark \triangle or dotted line with mark \triangle are critical for safety. Replace only with part number specified.

Les composants identifiés par une marque \triangle ou par une ligne pointillée avec une marque \triangle sont critiques pour la sécurité. Ne les remplacer que par une pièce portant le numéro spécifié.

- **B+**: B+ Line
- **B-**: B- Line
- \square : adjustment for repair
- Voltage and waveforms are dc with respect to ground under no-signal conditions.
- no mark: STOP
- ▶: PLAY
- ◻: REC
- ▶▶: FF
- ◀◀: REW
- ◀▶▶: AMS
- Voltages are taken with a VOM (Input impedance 10 M Ω)
- Voltage variations may be noted due to normal production tolerances.
- Signal path:
 - ◻: PB
 - ◻▶: REC

4-8. PRINTED WIRING BOARDS - SYSCON SECTION -

• Semiconductor Location

Ref. No.	Location	Ref. No.	Location
D701	I-15	IC805	B-14
D702	I-14	IC806	B-12
D703	I-15	IC902	J-6
D704	I-14	IC951	J-2
D705	I-14	IC952	J-2
D706	I-12	IC1001	G-10
D707	I-12	IC1002	G-9
D708	I-13		
D709	I-13	Q701	E-3
D710	I-14	Q702	D-4
D711	D-3	Q703	C-5
D712	E-8	Q704	C-5
D713	E-3	Q707	A-4
D714	D-5	Q708	D-9
D716	B-3	Q709	D-8
D717	A-5	Q801	B-6
D801	D-18	Q802	B-6
D802	D-18	Q803	B-6
D803	D-20	Q804	B-8
D804	B-9	Q805	B-9
D806	C-8	Q806	A-5
D807	D-7	Q807	C-5
		Q808	A-5
IC701	B-4	Q809	C-7
IC702	E-4	Q810	C-7
IC801	C-7	Q811	C-7
IC802	D-7	Q812	C-7
IC803	E-9	Q813	C-6
IC804	E-8		

Note on Mounting Diagram:
 • : parts extracted from the component side.

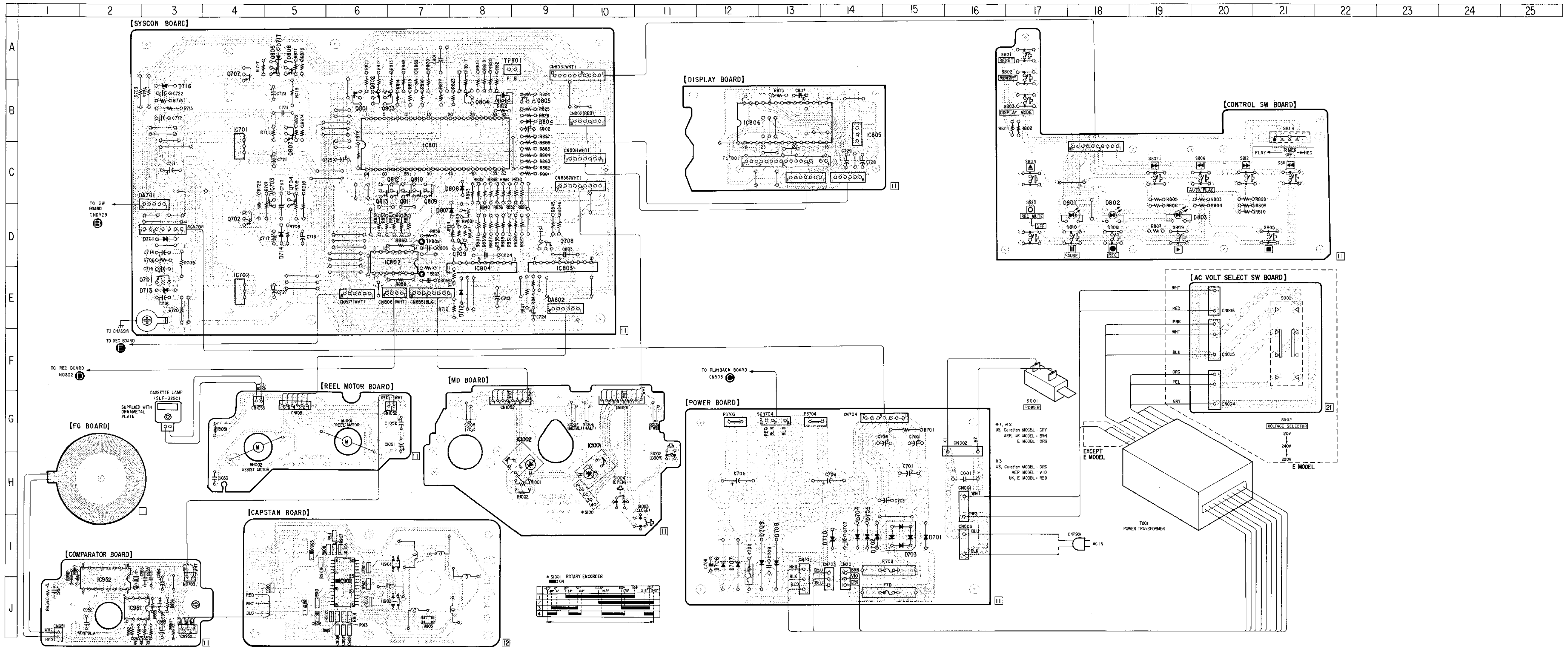

4-9. SCHEMATIC DIAGRAM - SYSCON SECTION -

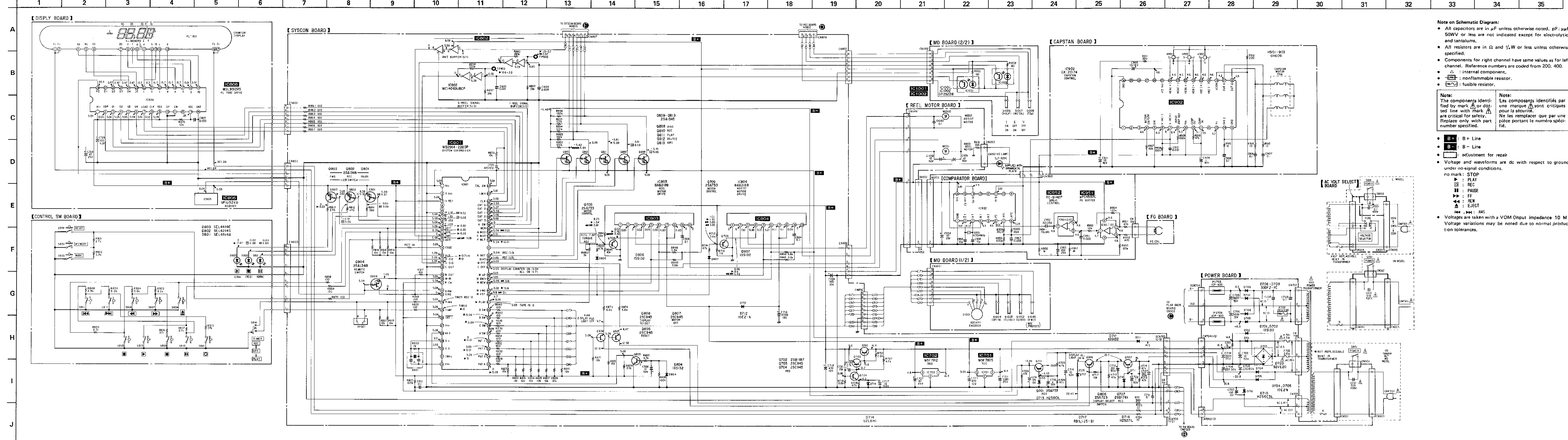

Note on Schematic Diagram:

- All capacitors are in μF unless otherwise noted. pF : μF 50WV or less are not indicated except for electrolytics and tantalums.
- All resistors are in Ω and $\frac{1}{2}W$ or less unless otherwise specified.
- Components for right channel have same values as for left channel. Reference numbers are coded from 200, 400.
- Δ : internal component.
- \square : nonflammable resistor.
- \square : fusible resistor.

Note:
The components identified by mark Δ or dotted line with mark Δ are critical for safety. Replace only with part number specified.

Note:
Les composants identifiés par une marque Δ sont critiques pour la sécurité. Ne les remplacer que par une pièce portant le numéro spécifié.

- $B+$: B+ Line
- $B-$: B- Line
- \square : adjustment for repair
- Voltage and waveforms are dc with respect to ground under no-signal conditions.
- no mark: STOP
- \blacktriangleright : PLAY
- \blacksquare : REC
- \square : PAUSE
- \blacktriangleleft : FF
- \blacktriangleleft : REW
- \blacktriangleleft : EJECT
- \blacktriangleleft : AMS
- Voltages are taken with a VOM (input impedance 10 M Ω). Voltage variations may be noted due to normal production tolerances.

SECTION 5
EXPLODED VIEWS

NOTE:

- The mechanical parts with no reference number in the exploded views are not supplied.
- The construction parts of an assembled part are indicated with a collation number in the remark column.
- Items marked "*" are not stocked since they are seldom required for routine service. Some delay should be anticipated when ordering these items.

- Due to standardization, parts with part number suffix -XX and -X may be different from the parts specified in the components used on the set.
- Color Indication of Appearance Parts
Example:
(RED) ... KNOB, BALANCE (WHITE)
↑ Cabinet's Color ↑ Parts' Color

The components identified by mark or dotted line with mark are critical for safety. Replace only with part number specified.

Les composants identifiés par une marque sont critiques pour la sécurité. Ne les remplacer que par une pièce portant le numéro spécifié.

5-1. PANEL SECTION

- ▲ A: DISPLAY BOARD
- ▲ B: HEADPHONE JACK BOARD
- ▲ C: CONTROL SW BOARD
- ▲ D: METER BOARD
- ▲ E: CAL SW BOARD
- ▲ F: POWER BOARD
- ▲ G: PIN JACK BOARD

- A: SW BOARD
- B: REC LEVEL BOARD
- C: PLAYBACK BOARD

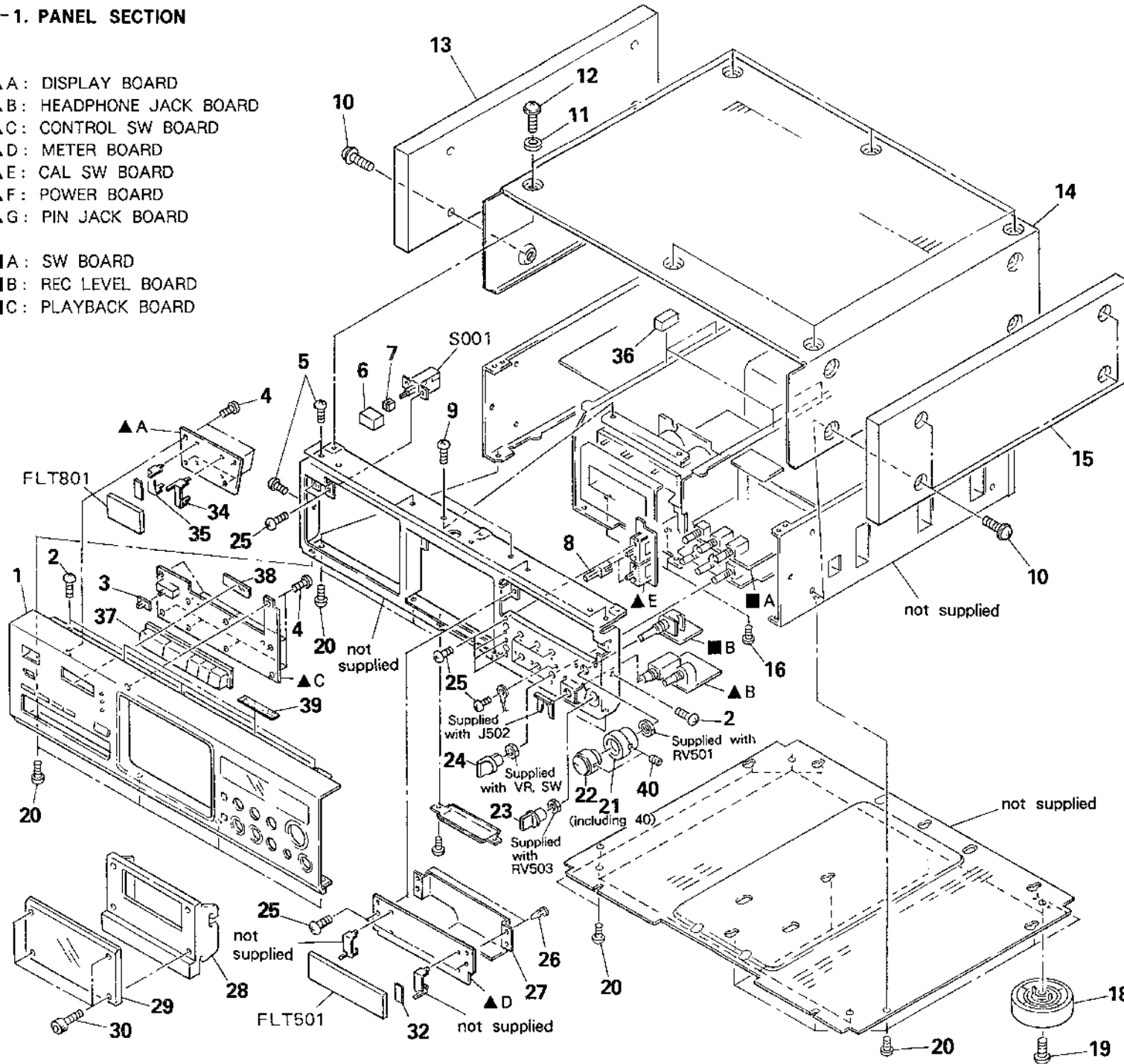

No.	Part No.	Description	Remarks
1	A-2003-464-A	(E).....PANEL ASSY, FRONT	
	A-2003-549-A	(US,Canadian)...PANEL ASSY, FRONT	38
	A-2003-551-A	(AEP,WG).....PANEL ASSY, FRONT	38
	A-2003-631-A	(UK).....PANEL ASSY, FRONT	
2	7-682-547-09	SCREW +B 3X6	
3	4-922-518-11	KNOB (TIMER)	
4	7-685-133-19	SCREW +BTP 2.6X6 TYPE2 N-S	
5	7-682-547-09	SCREW +BV 3X6, S TIGHT	
6	4-908-046-01	KNOB, SQUARE	
7	4-864-307-00	RING	
8	3-350-473-01	BUTTON	
9	7-685-870-01	SCREW +BVTT 3X5 (S)	
10	4-820-330-31	(UK)....SCREW, BW, PLUS MINUS	
	4-885-979-11	(EXCEPT UK).....SCREW (4X25)	
11	4-923-474-01	RING, ORNAMENTAL	
12	3-704-366-01	SCREW (CASE) (M3X8)	
13	X-3304-959-1	(US,Canadian,AEP,E)..PANEL(L) ASSY, SIDE	
	X-3304-969-1	(WG).....PANEL(L) ASSY, SIDE	
14	3-350-489-01	CASE	
15	X-3304-960-1	(US,Canadian,AEP,E)..PANEL(R) ASSY, SIDE	
	X-3304-970-1	(WG).....PANEL(R) ASSY, SIDE	
16	7-682-548-04	SCREW +BVTT 3X8 (S)	
18	X-3304-944-1	FOOT ASSY	
19	7-685-882-09	SCREW +BVTT 4X10 (S)	
20	3-703-685-21	SCREW (+BV 3X8)	
21	X-3304-924-1	KNOB (LEFT) ASSY, REC	
22	X-3304-925-1	KNOB (RIGHT) ASSY, REC	
23	3-346-380-11	KNOB (VOL)	
24	3-350-474-01	KNOB (DIA. 12), FLAT	
25	7-685-870-09	SCREW +BVTT 3X5 (S)	
26	4-812-134-11	RIVET NYLON, 3.5	
27	*3-356-940-01	PLATE, SHIELD	
28	3-356-923-01	LID, CASSETTE	
29	3-356-922-01	(E).....WINDOW, CASSETTE	
	3-356-922-21	(EXCEPT E)...WINDOW, CASSETTE	
30	3-356-942-01	SCREW (2.6X6), TAPPING	
32	9-911-863-XX	SPACER	
34	*3-350-476-01	BRACKET (FL)	
35	*3-356-938-01	BRACKET (FL)	
36	9-911-842-XX	CUSHION (S)	
37	X-3304-958-4	BUTTON ASSY	
38	3-350-471-11	(EXCEPT UK,E)...WINDOW, COUNTER	
39	9-911-835-XX	CUSHION, F	
40	3-701-505-00	SET SCREW, DOUBLE POINT 3X3	
FLT501	1-519-497-11	INDICATOR TUBE, FLUORESCENT	
FLT801	1-519-567-11	INDICATOR TUBE, FLUORESCENT	
S001	A1-554-920-11	SWITCH, PUSH (AC POWER)(1 KEY)	

- ▲ A: DISPLAY BOARD
- ▲ B: HEADPHONE JACK BOARD
- ▲ C: CONTROL SW BOARD
- ▲ D: METER BOARD
- ▲ E: CAL SW BOARD
- ▲ F: POWER BOARD
- ▲ G: PIN JACK BOARD

- A: SW BOARD
- B: REC LEVEL BOARD
- C: PLAYBACK BOARD
- D: AC VOLT SELECT SW BOARD

5-2. CHASSIS SECTION

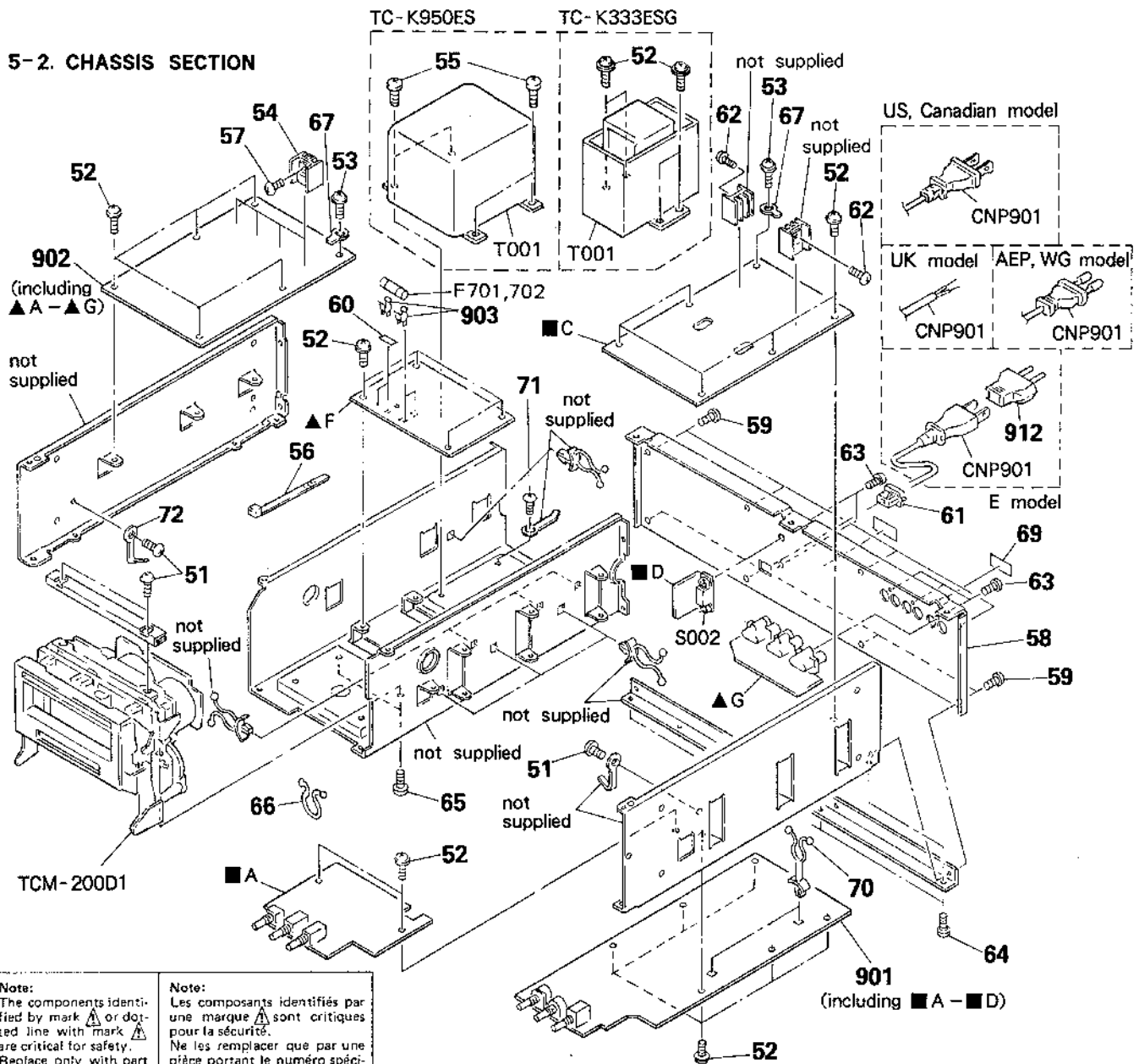

Note:
The components identified by mark ▲ or dotted line with mark ▲ are critical for safety. Replace only with part number specified.

Note:
Les composants identifiés par une marque ▲ ou trait pointillé avec une marque ▲ sont critiques pour la sécurité. Ne les remplacer que par une pièce portant le numéro spécifié.

No.	Part No.	Description	Remarks	No.	Part No.	Description	Remarks
51	7-685-870-09	SCREW +BVTI 3X5 (S)		70	*4-308-851-00	PURSE LOCK	
52	4-886-821-01	SCREW, S TIGHT, +PTTW 3X6		71	7-682-548-04	SCREW +BVTI 3X8 (S)	
53	7-682-548-04	SCREW, TIGHT, S		72	*3-701-822-00	HOLDER, WIRE	
54	*4-363-146-21	HEAT SINK, V.OUT		901	A-2006-185-A	MOUNTED PCB, AUDIO	
55	4-820-330-31	SCREW		902	A-2006-266-A	(E).....MOUNTED PCB, SYSTEM CONTROL	
56	3-655-653-21	BAND (TAITON), BINDING			A-2006-287-A	(EXCEPT E)...MOUNTED PCB, SYSTEM CONTROL	
57	7-685-646-79	SCREW +BVTP 3X8 TYPE2 IT-3		903	1-533-183-11	HOLDER, FUSE	
58	*3-350-482-01	(EXCEPT E)...PANEL, BACK		912	▲1-569-007-11	(E)...ADAPTOR, CONVERSION 2P	
	*3-350-482-11	(E).....PANEL, BACK		CNP901	▲1-559-297-31	(E).....CORD, POWER	
59	7-682-547-09	SCREW +BV 3X6, S TIGHT		CNP901	▲1-559-479-11	(US,Canadian)...CORD, POWER	
60	3-701-947-15	(AEP,UK,WG,E)...LABEL (T2.5A), FUSE		CNP901	▲1-574-383-11	(AEP,WG)...CORD, POWER	
	3-703-044-26	(US,Canadian)...LABEL, CAUTION		CNP901	▲1-574-384-11	(UK).....CORD, POWER	
61	*3-703-244-00	(AEP,UK,WG)...BUSHING (2104), CORD		F701	▲1-532-286-00	(AEP,WG,UK,E)...FUSE, TIME-LAG (2.5A)	
	4-916-783-01	(US,Canadian,E).....BUSHING, CORD		F701	▲1-532-744-11	(US,Canadian)...FUSE, GLASS TUBE (2.5A)	
62	7-682-147-15	SCREW, TR		F702	▲1-532-285-00	(AEP,WG,UK,E)...FUSE, TIME-LAG (2.5A)	
63	7-685-647-79	SCREW +BVTP 3X10 TYPE2 N-S		F702	▲1-532-744-11	(US,Canadian)...FUSE, GLASS TUBE (2.5A)	
64	3-703-685-21	SCREW (+BV 3X3)		S002	▲1-570-307-11	(E)...SWITCH, VOLTAGE CHANGE	
65	7-685-645-79	SCREW +BVTP 3X6 TYPE2 SLIT		T001	▲1-449-981-11	(US,Canadian)...TRANSFORMER, POWER	
66	3-315-159-01	PURSE LOCK (DIA. 14)		T001	▲1-449-982-11	(AEP,WG).....TRANSFORMER, POWER	
67	4-870-539-00	PLATE, GROUND		T001	▲1-449-983-11	(UK).....TRANSFORMER, POWER	
68	7-682-547-04	SCREW +BVTI 3X6 (S)		T001	▲1-449-984-11	(E).....TRANSFORMER, POWER	
69	*3-703-456-01	(AEP,WG,UK)...LABEL, AMS LICENSE					

5-3. MECHANISM SECTION (1)
(TCM-200D1)

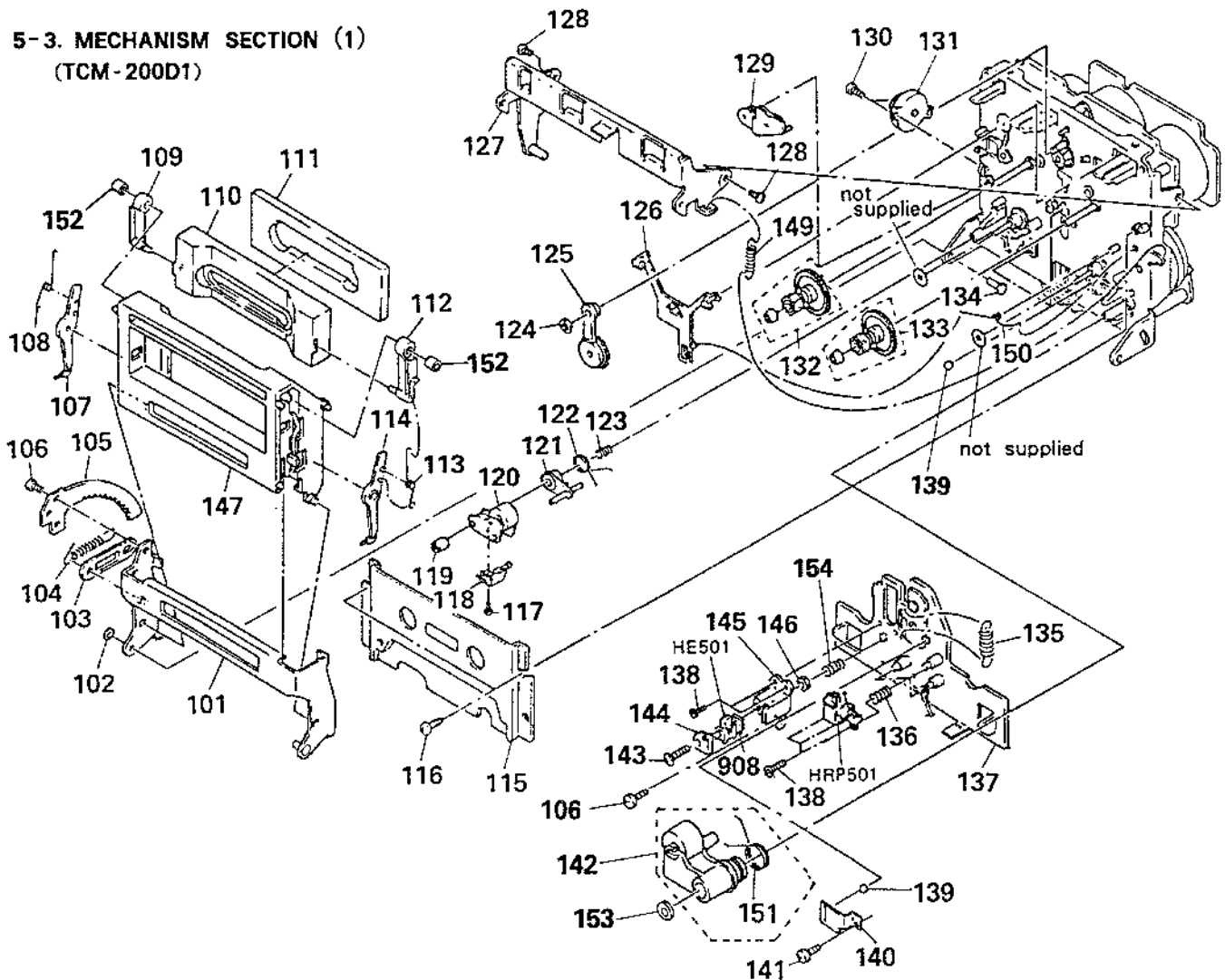

No.	Part No.	Description	Remarks	No.	Part No.	Description	Remarks
101	X-3356-612-1	HOLDER (B) ASSY, CASSETTE		129	X-3356-623-1	LEVER (BT) ASSY	
102	3-558-709-21	WASHER, STOPPER		130	7-685-851-09	SCREW +BVTT 2X4 (S)	
103	*3-356-717-01	LEVER (JOINT)		131	3-712-786-01	DAMPER, OIL	
104	3-356-626-01	SPRING, TENSION		132	X-3356-629-1	GERA (S) ASSY	
105	3-356-708-01	GEAR (SOFT EJECT)		133	X-3356-627-1	GEAR (T) ASSY	
106	7-621-775-10	SCREW +B 2.6X4		134	3-356-710-01	SHAFT (LEFT) (CASSETTE HOLDER)	
107	3-356-932-01	LEVER (LA)		135	3-356-658-01	SPRING (LIMITER H), TENSION	
108	3-356-927-01	SPRING (LEFT), TORSION		136	3-356-659-01	SPRING (RPH), COMPRESSION	
109	3-356-933-01	LEVER (LB)		137	*X-3356-617-1	SLIDER (HEAD PC BOARD) ASSY	
110	3-356-928-01	PLATE (A), ORNAMENTAL		138	7-621-772-10	SCREW +B 2X4	
111	*3-356-929-01	ABSORBENT, VIBRATION		139	7-671-154-01	STENLESS BALL	
112	3-356-931-01	LEVER (RB)		140	3-356-656-01	SPRING (HEAD PC BOARD), LEAF	
113	3-356-926-01	SPRING (RIGHT), TORSION		141	7-685-870-01	SCREW +BVTT 3X5 (S)	
114	3-356-930-01	LEVER (RA)		142	X-3356-620-1	LEVER (PINCH LEVER T) ASSY	
115	X-3356-613-1	PLATE ASSY, ORNAMENTAL		143	7-621-772-70	SCREW +B 2X14	
116	7-685-133-19	SCREW +BTP 2.6X6 TYPE2 N-S		144	3-318-433-01	SPRING	
117	7-628-253-00	SCREW +PS 2X4		145	*3-576-977-00	BRACKET, E. HEAD	
118	3-564-138-00	GUIDE (S), TAPE		146	7-622-205-05	NUT M2 TYPE2	
119	3-356-652-01	NJT (PINCH LEVER S)		147	X-3356-611-1	HOLDER (A) ASSY, CASSETTE	
120	X-3356-621-1	LEVER (PINCH LEVER S) ASSY		149	3-356-624-01	SPRING, TENSION	
121	3-356-660-01	LEVER (PS)		150	3-356-619-01	SPRING (B), TORSION	
122	3-356-661-01	SPRING (PINCH LEVER S), TORSION		151	3-356-672-01	SPRING (PINCH LEVER T), TORSION	
123	3-356-657-01	SPRING (PS), COMPRESSION		152	3-355-946-01	BUSHING	
124	3-669-465-00	WASHER (1.5), STOPPER		153	3-669-596-00	WASHER (2.3), STOPPER	
125	X-3356-641-1	LEVER (FR2) ASSY		154	3-564-121-00	SPRING, COMPRESSION	
126	3-356-614-01	SLIDER (BRAKE)		908	*1-608-268-00	PC BOARD, ERASE HEAD	
127	*X-3356-608-1	LEVER (LIFTER) ASSY		HE501	1-543-358-11	HEAD, MAGNETIC (ERASE)	
128	3-356-601-11	SCREW, STEP		HRP501	1-543-684-11	HEAD, MAGNETIC (REC/PB)	

5-4. MECHANISM SECTION (2)
(TCM-200D1)

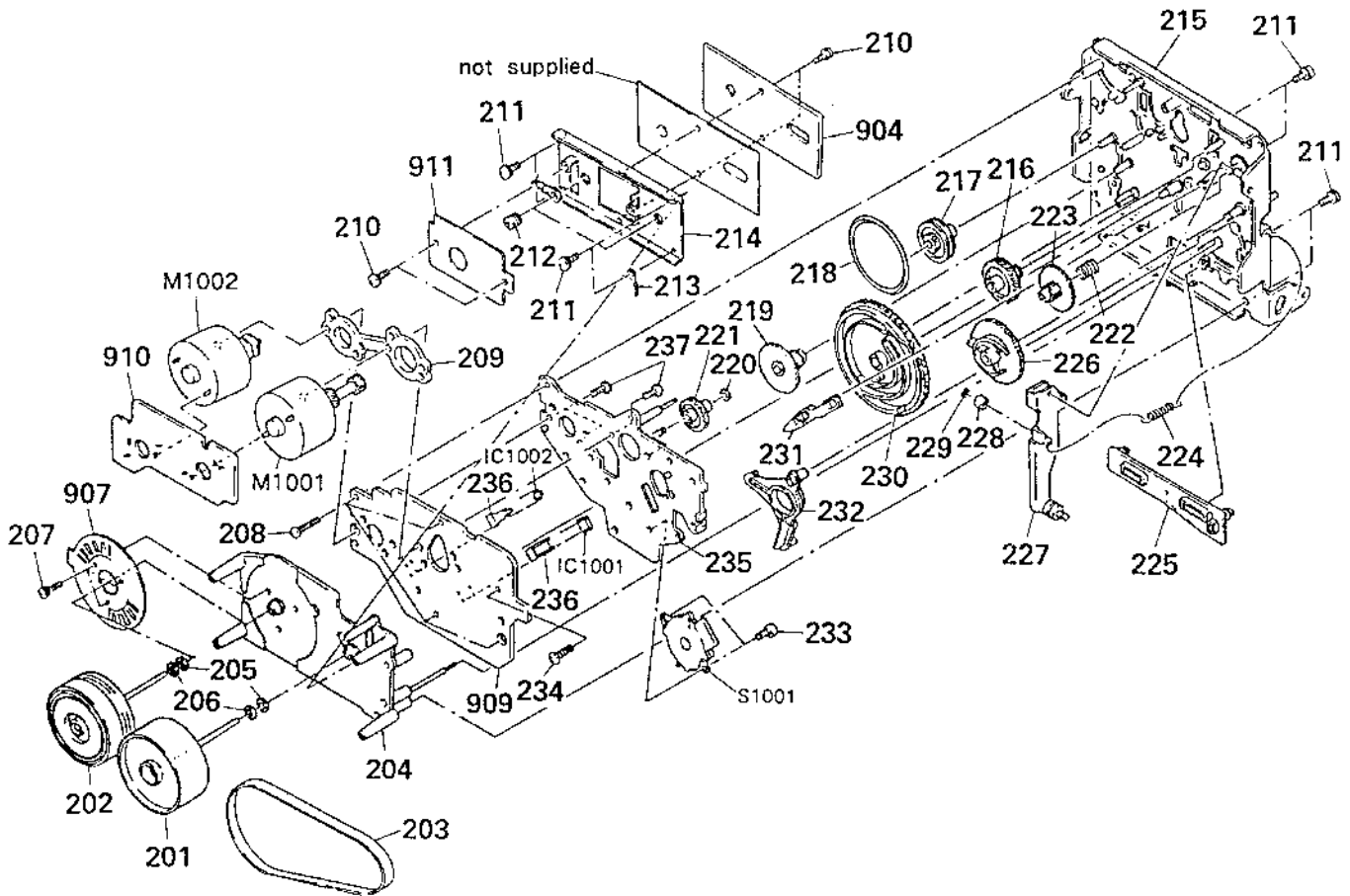

No.	Part No.	Description	Remarks	No.	Part No.	Description	Remarks
201	X-3356-626-1	FLYWHEEL (S) ASSY		224	3-356-625-01	SPRING, TENSION	
202	X-3356-619-1	FLYWHEEL (DT) ASSY		225	3-356-653-01	SLIDER (PAUSE)	
203	3-564-088-00	BELT (2), CAPSTAN		226	3-356-616-01	GEAR (LOADING CAM)	
204	*X-3356-614-1	DECK (D1) ASSY		227	*X-3356-606-1	LEVER (LOADING) ASSY	
205	3-356-705-31	WASHER (CAPSTAN)		228	3-356-630-01	ROLLER (LOADING)	
206	3-356-705-21	WASHER (CAPSTAN)		229	3-558-708-11	WASHER, STOPPER	
207	7-628-254-10	SCREW +PS 2.6X6		230	3-356-654-01	GEAR (MODE CAM C)	
208	3-355-801-01	SCREW (BTP 2X18)		231	3-356-617-01	LEVER (SELECTION)	
209	*3-356-628-01	SPACER (MOTOR)		232	3-356-613-01	LEVER (MODE)	
210	7-685-870-01	SCREW +BVT 3X5 (S)		233	7-621-772-20	SCREW +B 2X5	
211	7-682-648-09	SCREW +PS 3X8		234	3-356-707-01	SCREW (+PTPWH 2X25)	
212	3-489-073-00	SCREW, THRUST		235	*X-3356-616-1	BRACKET (MOTOR D) ASSY	
213	*3-701-822-00	HOLDER, WIRE		236	3-356-631-01	HOLDER (SENSOR)	
214	*X-3356-615-1	BRACKET(THRUST RETAINER D)ASSY		237	7-621-773-95	SCREW +B 2.6X6	
215	X-3356-622-1	CHASSIS (C) ASSY, MECHANICAL		904	A-2006-154-A	MOUNTED PCB, CAPSTAN C.O.C	
216	3-356-703-01	GEAR (COMMUNICATION C)		907	1-632-779-11	PC BOARD, FG	
217	3-356-607-01	PULLEY (MODE)		909	*1-632-740-11	PC BOARD, MD	
218	3-356-603-01	BELT (MODE)		910	*1-632-741-11	PC BOARD, REEL MOTOR	
219	3-356-606-01	GEAR (MODE)		911	*1-632-746-11	PC BOARD, COMPARATOR	
220	3-669-465-00	WASHER (1.5), STOPPER		M1002	X-3356-604-1	MOTOR (ASSIST) ASSY	
221	3-356-702-01	GEAR (COMMUNICATION B)		M1001	X-3356-638-1	MOTOR (REEL R) ASSY	
222	3-356-605-01	SPRING, COMPRESSION		S1001	1-466-238-11	ENCODER, ROTARY	
223	3-356-609-01	GEAR (LOADING)					

SECTION 6 ELECTRICAL PARTS LIST

NOTE:

- Due to standardization, replacements in the parts list may be different from the parts specified in the diagrams or the components used on the set.
- Items marked "*" are not stocked since they are seldom required for routine service. Some delay should be anticipated when ordering these items.
- If there are two or more same circuits in a set such as a stereophonic machine, only typical circuit parts may be indicated and capacitors and resistors in other same circuits may be omitted.

CAPACITORS:
MF: μ F, PF: μ PF.

RESISTORS
• All resistors are in ohms.
• F: nonflammable

COILS
• MMH: mH, UH: μ H

SEMICONDUCTORS
In each case, U: μ , for example:
UA...: μ A..., UPA...: μ PA...,
UPC...: μ PC, UPD...: μ PD...

The components identified by mark Δ or dotted line with mark Δ are critical for safety. Replace only with part number specified.

Les composants identifiés par une marque Δ sont critiques pour la sécurité. Ne les remplacer que par une pièce portant le numéro spécifié.

Ref.No.	Part No.	Description	Ref.No.	Part No.	Description			
901	A-2006-185-A	MOUNTED PCB, AUDIO	C133	1-136-173-00	FILM	0.47MF	5%	50V
902	A-2006-266-A A-2006-287-A	(E).....MOUNTED PCB, SYSTEM CONTROL (EXCEPT E)..MOUNTED PCB, SYSTEM CONTROL	C134	1-136-167-00	FILM	0.15MF	5%	50V
903	1-533-183-11	HOLDER, FUSE	C135	1-136-155-00	FILM	0.015MF	5%	50V
904	A-2006-154-A	MOUNTED PCB, CAPSTAN C.O.C	C136	1-123-380-00	ELECT	1MF	20%	50V
907	1-632-779-11	PC BOARD, FG	C137	1-136-169-00	FILM	0.22MF	5%	50V
908	*1-608-268-00	PC BOARD, ERASE HEAD	C138	1-136-163-00	FILM	0.068MF	5%	50V
909	*1-632-740-11	PC BOARD, MD	C139	1-136-162-00	FILM	0.056MF	5%	50V
910	*1-632-741-11	PC BOARD, REEL MOTOR	C140	1-123-380-00	ELECT	1MF	20%	50V
911	*1-632-746-11	PC BOARD, COMPARATOR	C141	1-130-480-00	MYLAR	0.0056MF	5%	50V
912	Δ 1-569-007-11	(E)...ADAPTOR, CONVERSION 2P	C142	1-136-153-00	FILM	0.01MF	5%	50V
C001	1-161-744-00	CERAMIC	C143	1-124-929-11	ELECT	22MF	20%	63V
C101	1-136-252-00	FILM	C144	1-124-929-11	ELECT	22MF	20%	63V
C102	1-130-893-00	FILM	C145	1-136-250-11	FILM	0.001MF	5%	100V
C103	1-124-130-00	ELECT	C146	1-136-252-00	FILM	0.0015MF	5%	100V
C104	1-124-748-11	ELECT	C147	1-136-252-00	FILM	0.0015MF	5%	100V
C105	1-124-748-11	ELECT	C148	1-124-915-11	ELECT	10MF	20%	63V
C106	1-136-169-00	FILM	C149	1-136-230-00	FILM	0.0022MF	5%	100V
C107	1-136-230-00	FILM	C150	1-136-163-00	FILM	0.068MF	5%	50V
C108	1-136-230-00	FILM	C151	1-130-892-00	FILM	0.015MF	5%	100V
C109	1-136-230-00	FILM	C152	1-136-160-00	FILM	0.039MF	5%	50V
C110	1-130-475-00	MYLAR	C153	1-130-892-00	FILM	0.015MF	5%	100V
C111	1-130-475-00	MYLAR	C154	1-136-160-00	FILM	0.039MF	5%	50V
C112	1-130-478-00	MYLAR	C155	1-136-594-11	FILM	0.018MF	5%	100V
C113	1-136-173-00	FILM	C156	1-136-230-00	FILM	0.0022MF	5%	100V
C114	1-136-167-00	FILM	C157	1-124-929-11	ELECT	22MF	20%	63V
C115	1-136-155-00	FILM	C158	1-136-252-00	FILM	0.0015MF	5%	100V
C116	1-123-380-00	ELECT	C159	1-107-157-00	MICA	27PF	5%	500V
C117	1-136-169-00	FILM	C160	1-136-230-00	FILM	0.0022MF	5%	100V
C118	1-136-163-00	FILM	C161	1-124-767-00	ELECT	2.2MF	20%	50V
C119	1-136-162-00	FILM	C162	1-124-925-11	ELECT	2.2MF	20%	50V
C120	1-123-380-00	ELECT	C163	1-124-927-11	ELECT	4.7MF	20%	50V
C121	1-130-480-00	MYLAR	C164	1-136-165-00	FILM	0.1MF	5%	50V
C122	1-136-153-00	FILM	C166	1-123-875-11	ELECT	10MF	20%	50V
C123	1-124-929-11	ELECT	C167	1-136-437-11	FILM	220PF	5%	630V
C124	1-124-929-11	ELECT	C168	1-136-153-00	FILM	0.01MF	5%	50V
C125	1-123-369-00	ELECT	C169	1-136-433-11	FILM	100PF	5%	630V
C126	1-123-369-00	ELECT	C170	1-136-435-11	FILM	150PF	5%	630V
C127	1-124-767-00	ELECT	C171	1-136-165-00	FILM	0.1MF	5%	50V
C128	1-107-159-00	MICA	C172	1-136-157-00	FILM	0.022MF	5%	50V
C129	1-107-159-00	MICA	C173	1-107-169-00	MICA	100PF	5%	500V
C130	1-130-475-00	MYLAR	C174	1-123-369-00	ELECT	4.7MF	20%	63V
C131	1-130-475-00	MYLAR	C175	1-123-369-00	ELECT	4.7MF	20%	63V
C132	1-130-478-00	MYLAR	C176	1-136-252-00	FILM	0.0015MF	5%	100V
			C201	1-136-252-00	FILM	0.0015MF	5%	100V
			C202	1-130-893-00	FILM	0.027MF	3%	100V

Ref.No.	Part No.	Description				Ref.No.	Part No.	Description			
C203	1-124-130-00	ELECT	100MF	20%	63V	C260	1-136-230-00	FILM	0.0022MF	5%	100V
C204	1-124-748-11	ELECT	22MF	20%	100V	C261	1-124-767-00	ELECT	2.2MF	20%	50V
C205	1-124-748-11	ELECT	22MF	20%	100V	C262	1-124-925-11	ELECT	2.2MF	20%	50V
C206	1-136-169-00	FILM	0.22MF	5%	50V	C263	1-124-927-11	ELECT	4.7MF	20%	50V
C207	1-136-230-00	FILM	0.0022MF	5%	100V	C264	1-124-767-00	ELECT	2.2MF	20%	50V
C208	1-136-230-00	FILM	0.0022MF	5%	100V	C265	1-161-375-00	CERAMIC	0.0022MF	20%	16V
C209	1-136-230-00	FILM	0.0022MF	5%	100V	C266	1-123-875-11	ELECT	10MF	20%	50V
C210	1-130-475-00	MYLAR	0.0022MF	5%	50V	C267	1-136-437-11	FILM	220PF	5%	630V
C211	1-130-475-00	MYLAR	0.0022MF	5%	50V	C268	1-136-153-00	FILM	0.01MF	5%	50V
C212	1-130-478-00	MYLAR	0.0039MF	5%	50V	C269	1-136-433-11	FILM	100PF	5%	630V
C213	1-136-173-00	FILM	0.47MF	5%	50V	C270	1-136-435-11	FILM	150PF	5%	630V
C214	1-136-167-00	FILM	0.15MF	5%	50V	C271	1-136-165-00	FILM	0.1MF	5%	50V
C215	1-136-155-00	FILM	0.015MF	5%	50V	C272	1-136-157-00	FILM	0.022MF	5%	50V
C216	1-123-380-00	ELECT	1MF	20%	50V	C273	1-107-169-00	MICA	100PF	5%	500V
C217	1-135-169-00	FILM	0.22MF	5%	50V	C274	1-123-369-00	ELECT	4.7MF	20%	63V
C218	1-136-163-00	FILM	0.068MF	5%	50V	C275	1-123-369-00	ELECT	4.7MF	20%	63V
C219	1-136-162-00	FILM	0.056MF	5%	50V	C276	1-136-252-00	FILM	0.0015MF	5%	100V
C220	1-123-380-00	ELECT	1MF	20%	50V	C501	1-123-377-00	ELECT	470MF	20%	63V
C221	1-130-480-00	MYLAR	0.0056MF	5%	50V	C502	1-123-377-00	ELECT	470MF	20%	63V
C222	1-136-153-00	FILM	0.01MF	5%	50V	C503	1-123-333-00	ELECT	100MF	20%	25V
C223	1-124-929-11	ELECT	22MF	20%	63V	C504	1-123-333-00	ELECT	100MF	20%	25V
C224	1-124-929-11	ELECT	22MF	20%	63V	C505	1-107-159-00	MICA	33PF	5%	500V
C225	1-123-369-00	ELECT	4.7MF	20%	63V	C506	1-107-159-00	MICA	33PF	5%	500V
C226	1-123-369-00	ELECT	4.7MF	20%	63V	C507	1-124-922-11	ELECT	1000MF	20%	63V
C227	1-124-767-00	ELECT	2.2MF	20%	50V	C508	1-124-922-11	ELECT	1000MF	20%	63V
C228	1-107-159-00	MICA	33PF	5%	500V	C509	1-123-875-11	ELECT	10MF	20%	50V
C229	1-107-159-00	MICA	33PF	5%	500V	C510	1-124-927-11	ELECT	4.7MF	20%	50V
C230	1-130-475-00	MYLAR	0.0022MF	5%	50V	C511	1-123-333-00	ELECT	100MF	20%	16V
C231	1-130-475-00	MYLAR	0.0022MF	5%	50V	C512	1-123-333-00	ELECT	100MF	20%	16V
C232	1-130-478-00	MYLAR	0.0039MF	5%	50V	C513	1-124-477-11	ELECT	47MF	20%	25V
C233	1-136-173-00	FILM	0.47MF	5%	50V	C514	1-124-477-11	ELECT	47MF	20%	25V
C234	1-136-167-00	FILM	0.15MF	5%	50V	C515	1-124-927-11	ELECT	4.7MF	20%	50V
C235	1-136-155-00	FILM	0.015MF	5%	50V	C516	1-126-233-11	ELECT	22MF	20%	50V
C236	1-123-380-00	ELECT	1MF	20%	50V	C517	1-123-875-11	ELECT	10MF	20%	50V
C237	1-136-169-00	FILM	0.22MF	5%	50V	C518	1-126-233-11	ELECT	22MF	20%	50V
C238	1-136-163-00	FILM	0.068MF	5%	50V	C519	1-123-875-11	ELECT	10MF	20%	50V
C239	1-136-162-00	FILM	0.056MF	5%	50V	C520	1-124-902-00	ELECT	0.47MF	20%	50V
C240	1-123-380-00	ELECT	1MF	20%	50V	C521	1-124-915-11	ELECT	10MF	20%	63V
C241	1-130-480-00	MYLAR	0.0056MF	5%	50V	C522	1-124-915-11	ELECT	10MF	20%	63V
C242	1-136-153-00	FILM	0.01MF	5%	50V	C523	1-107-046-00	MICA	4.7PF	0.5PF	500V
C243	1-124-929-11	ELECT	22MF	20%	63V	C524	1-130-478-00	MYLAR	0.0039MF	5%	50V
C244	1-124-929-11	ELECT	22MF	20%	63V	C527	1-123-369-00	ELECT	4.7MF	20%	63V
C245	1-136-250-11	FILM	0.001MF	5%	100V	C528	1-123-369-00	ELECT	4.7MF	20%	63V
C246	1-136-252-00	FILM	0.0015MF	5%	100V	C529	1-130-474-00	MYLAR	0.0018MF	5%	50V
C247	1-136-252-00	FILM	0.0015MF	5%	100V	C530	1-130-474-00	MYLAR	0.0018MF	5%	50V
C248	1-124-915-11	ELECT	10MF	20%	63V	C531	1-136-157-00	FILM	0.022MF	5%	50V
C249	1-136-230-00	FILM	0.0022MF	5%	100V	C532	1-136-157-00	FILM	0.022MF	5%	50V
C250	1-136-163-00	FILM	0.068MF	5%	50V	C533	1-124-477-11	ELECT	47MF	20%	25V
C251	1-130-892-00	FILM	0.015MF	5%	100V	C534	1-124-477-11	ELECT	47MF	20%	25V
C252	1-136-160-00	FILM	0.039MF	5%	50V	C535	1-162-294-31	CERAMIC	0.001MF	10%	50V
C253	1-130-892-00	FILM	0.015MF	5%	100V	C536	1-162-294-31	CERAMIC	0.001MF	10%	50V
C254	1-136-160-00	FILM	0.039MF	5%	50V	C537	1-162-291-31	CERAMIC	560PF	10%	50V
C255	1-136-594-11	FILM	0.018MF	5%	100V	C538	1-162-291-31	CERAMIC	560PF	10%	50V
C256	1-136-230-00	FILM	0.0022MF	5%	100V	C539	1-131-368-00	TANTALUM	3.3MF	20%	16V
C257	1-124-929-11	ELECT	22MF	20%	63V	C540	1-136-802-11	FILM	0.015MF	5%	100V
C258	1-136-252-00	FILM	0.0015MF	5%	100V	C543	1-124-477-11	ELECT	47MF	20%	25V
C259	1-107-157-00	MICA	27PF	5%	500V	C544	1-124-477-11	ELECT	47MF	20%	25V

Ref.No.	Part No.	Description				
C545	1-124-477-11	ELECT	47MF	20%	25V	
C546	1-124-477-11	ELECT	47MF	20%	25V	
C547	1-124-902-00	ELECT	0.47MF	20%	50V	
C548	1-123-875-11	ELECT	10MF	20%	50V	
C549	1-124-925-11	ELECT	2.2MF	20%	50V	
C701	1-124-636-00	ELECT	3300MF	20%	25V	
C702	1-123-875-11	ELECT	10MF	20%	50V	
C703	1-124-911-11	ELECT	220MF	20%	50V	
C704	1-124-911-11	ELECT	220MF	20%	50V	
C705	1-126-982-11	ELECT	5600MF	20%	0	
C706	1-126-982-11	ELECT	5600MF	20%	0	
C707	1-124-443-00	ELECT	100MF	20%	10V	
C708	1-136-177-00	FILM	1MF	5%	50V	
C709	1-136-165-00	FILM	0.1MF	5%	50V	
C711	1-124-636-00	ELECT	3300MF	20%	25V	
C712	1-124-122-11	ELECT	100MF	20%	50V	
C713	1-124-898-11	ELECT	4700MF	20%	16V	
C714	1-123-875-11	ELECT	10MF	20%	50V	
C715	1-124-791-11	ELECT	1MF	20%	50V	
C716	1-124-443-00	ELECT	100MF	20%	10V	
C717	1-123-875-11	ELECT	10MF	20%	50V	
C718	1-124-472-11	ELECT	470MF	20%	10V	
C721	1-124-472-11	ELECT	470MF	20%	10V	
C722	1-124-791-11	ELECT	1MF	20%	50V	
C723	1-124-122-11	ELECT	100MF	20%	50V	
C724	1-124-443-00	ELECT	100MF	20%	10V	
C725	1-124-472-11	ELECT	470MF	20%	10V	
C727	1-124-477-11	ELECT	47MF	20%	25V	
C728	1-124-477-11	ELECT	47MF	20%	25V	
C729	1-126-177-11	ELECT	100MF	20%	6.3V	
C730	1-162-211-31	CERAMIC	33PF	5%	50V	
C731	1-164-159-11	CERAMIC	0.1MF		50V	
C801	1-164-159-11	CERAMIC	0.1MF		50V	
C802	1-123-875-11	ELECT	10MF	20%	50V	
C803	1-164-159-11	CERAMIC	0.1MF		50V	
C804	1-164-159-11	CERAMIC	0.1MF		50V	
C805	1-162-294-31	CERAMIC	0.001MF	10%	50V	
C806	1-162-294-31	CERAMIC	0.001MF	10%	50V	
C807	1-136-159-00	FILM	0.033MF	5%	50V	
C905	1-124-779-00	ELECT CHIP	10MF	20%	16V	
C906	1-135-091-00	TANTAL. CHIP	1MF	10%	16V	
C907	1-163-077-00	CERAMIC CHIP	0.1MF		50V	
C908	1-163-077-00	CERAMIC CHIP	0.1MF		50V	
C909	1-163-077-00	CERAMIC CHIP	0.1MF		50V	
C910	1-163-205-00	CERAMIC CHIP	0.001MF	10%	50V	
C911	1-124-779-00	ELECT CHIP	10MF	20%	16V	
C951	1-136-157-00	FILM	0.022MF	5%	50V	
C952	1-124-282-00	ELECT	22MF	20%	25V	
C953	1-124-478-11	ELECT	100MF	20%	25V	
C954	1-124-477-11	ELECT	47MF	20%	25V	
C955	1-162-203-31	CERAMIC	15PF	5%	50V	
C956	1-162-203-31	CERAMIC	15PF	5%	50V	
C957	1-136-159-00	FILM	0.033MF	5%	50V	
C1051	1-123-875-11	ELECT	10MF	20%	50V	
C1052	1-123-875-11	ELECT	10MF	20%	50V	
C1053	1-164-159-11	CERAMIC	0.1MF		50V	
CN001	*1-564-321-00	PIN, CONNECTOR			2P	
CN002	*1-565-792-11	PIN, CONNECTOR			2P	
CN003	*1-564-321-00	PIN, CONNECTOR			2P	
CN004	*1-569-223-11	PIN, CONNECTOR			4P	
CN005	*1-569-223-11	PIN, CONNECTOR			4P	
CN006	*1-568-226-11	PIN, CONNECTOR			2P	
CN701	*1-564-506-11	PLUG, CONNECTOR			3P	
CN702	*1-564-104-00	PIN, CONNECTOR			3P	
CN703	*1-564-506-11	PLUG, CONNECTOR			3P	
CN704	*1-564-510-11	PLUG, CONNECTOR			7P	
CN801	*1-564-341-11	PIN, CONNECTOR			7P	
CN802	*1-564-340-71	PIN, CONNECTOR			6P	
CN803	*1-564-666-11	PIN, CONNECTOR			10P	
CN806	*1-564-338-00	PIN, CONNECTOR			4P	
CN807	*1-564-340-00	PIN, CONNECTOR			6P	
CN855	*1-564-342-61	PIN, CONNECTOR			8P	
CN856	*1-506-503-11	PIN, CONNECTOR			9P	
CN951	*1-564-718-11	PIN, CONNECTOR (SMALL TYPE)			2P	
CN952	*1-564-518-11	PLUG, CONNECTOR			3P	
CN1001	1-506-615-11	PIN, CONNECTOR			9P	
CN1002	1-564-501-11	PIN, CONNECTOR			8P	
CN1051	*1-564-499-11	PIN, CONNECTOR			6P	
CN1052	*1-564-718-11	PIN, CONNECTOR (SMALL TYPE)			2P	
CN1053	*1-564-718-11	PIN, CONNECTOR (SMALL TYPE)			2P	
CND501	*1-564-337-71	PIN, CONNECTOR			3P	
CND505	*1-564-336-61	PIN, CONNECTOR			2P	
CND513	*1-564-338-61	PIN, CONNECTOR			4P	
CND522	*1-564-340-71	PIN, CONNECTOR			6P	
CND523	*1-564-338-00	PIN, CONNECTOR			4P	
CND524	*1-564-339-00	PIN, CONNECTOR			5P	
CND525	*1-564-340-61	PIN, CONNECTOR			6P	
CND526	*1-564-340-81	PIN, CONNECTOR			6P	
CND527	*1-564-341-11	PIN, CONNECTOR			7P	
CND528	*1-564-338-71	PIN, CONNECTOR			4P	
CND529	*1-564-339-71	PIN, CONNECTOR			5P	
CND531	*1-564-339-61	PIN, CONNECTOR			5P	
CND532	*1-564-339-81	PIN, CONNECTOR			5P	
CND533	*1-564-340-00	PIN, CONNECTOR			6P	
CNE507	*1-564-507-11	PLUG, CONNECTOR			4P	
CNE508	*1-564-506-11	PLUG, CONNECTOR			3P	
CNE514	*1-564-508-11	PLUG, CONNECTOR			5P	
CNE516	*1-564-507-11	PLUG, CONNECTOR			4P	
CNE520	*1-564-509-11	PLUG, CONNECTOR			5P	
CNE521	*1-564-509-11	PLUG, CONNECTOR			6P	
CNE534	*1-564-511-11	PLUG, CONNECTOR			8P	
CNE535	*1-564-506-11	PLUG, CONNECTOR			3P	
CNE536	*1-564-506-11	PLUG, CONNECTOR			3P	
CNE537	*1-564-507-11	PLUG, CONNECTOR			4P	
CNN502	*1-560-338-00	PIN, CONNECTOR			7P	
CNN506	*1-560-062-00	PIN, CONNECTOR			4P	
CNN509	*1-560-061-00	PIN, CONNECTOR			3P	
CNN510	*1-560-061-00	PIN, CONNECTOR			3P	
CNN511	*1-560-062-00	PIN, CONNECTOR			4P	
CNN512	*1-560-061-00	PIN, CONNECTOR			3P	
CNN515	*1-560-061-00	PIN, CONNECTOR			3P	
CNN517	*1-560-062-00	PIN, CONNECTOR			4P	
CNN518	*1-560-062-00	PIN, CONNECTOR			4P	
CNN519	*1-560-062-00	PIN, CONNECTOR			4P	

Ref.No.	Part No.	Description
CNP901A1	559-297-31	(E).....CORD, POWER
CNP901A1	559-479-11	(US,Canadian)...CORD, POWER
CNP901A1	574-383-11	(AEP,WG).....CORD, POWER
CNP901A1	574-384-11	(UK).....CORD, POWER
CNV503*1	564-104-00	PIN, CONNECTOR 3P
CP501	1-466-252-11	OSCILLATION UNIT, BIAS
D101	8-719-107-94	DIODE 1SS202-1
D201	8-719-107-94	DIODE 1SS202-1
D503	8-719-910-65	DIODE HZ6B2L
D504	8-719-910-65	DIODE HZ6B2L
D505	8-719-001-57	DIODE UZL-11H3
D506	8-719-107-94	DIODE 1SS202-1
D507	8-719-107-94	DIODE 1SS202-1
D508	8-719-107-94	DIODE 1SS202-1
D509	8-719-107-94	DIODE 1SS202-1
D510	8-719-107-94	DIODE 1SS202-1
D511	8-719-107-94	DIODE 1SS202-1
D512	8-719-107-94	DIODE 1SS202-1
D513	8-719-107-94	DIODE 1SS202-1
D514	8-719-001-57	DIODE UZL-11H3
D515	8-719-001-57	DIODE UZL-11H3
D516	8-719-107-94	DIODE 1SS202-1
D517	8-719-107-94	DIODE 1SS202-1
D518	8-719-107-94	DIODE 1SS202-1
D519	8-719-107-94	DIODE 1SS202-1
D520	8-719-107-94	DIODE 1SS202-1
D521	8-719-933-54	DIODE UZS9A2L
D522	8-719-107-94	DIODE 1SS202-1
D523	8-719-107-94	DIODE 1SS202-1
D524	8-719-001-57	DIODE UZL-11H3
D525	8-719-107-94	DIODE 1SS202-1
D526	8-719-107-94	DIODE 1SS202-1
D527	8-719-114-29	DIODE RD5.1JS-B1
D528	8-719-114-29	DIODE RD5.1JS-B1
D529	8-719-001-57	DIODE UZL-11H3
D530	8-719-001-57	DIODE UZL-11H3
D531	8-719-114-29	DIODE RD5.1JS-B1
D532	8-719-933-54	DIODE UZS9A2L
D533	8-719-107-94	DIODE 1SS202-1
D534	8-719-107-94	DIODE 1SS202-1
D535	8-719-107-94	DIODE 1SS202-1
D536	8-719-114-29	DIODE RD5.1JS-B1
D537	8-719-107-94	DIODE 1SS202-1
D538	8-719-107-94	DIODE 1SS202-1
D539	8-719-107-94	DIODE 1SS202-1
D540	8-719-107-94	DIODE 1SS202-1
D541	8-719-114-29	DIODE RD5.1JS-B1
D542	8-719-107-94	DIODE 1SS202-1
D543	8-719-107-94	DIODE 1SS202-1
D544	8-719-107-94	DIODE 1SS202-1
D545	8-719-107-94	DIODE 1SS202-1
D546	8-719-000-84	DIODE UZL-7M1
D547	8-719-000-84	DIODE UZL-7M1
D548	8-719-107-94	DIODE 1SS202-1
D549	8-719-107-94	DIODE 1SS202-1
D550	8-719-301-52	LED SEL2810A-C
D551	8-719-107-94	DIODE 1SS202-1

Ref.No.	Part No.	Description
D552	8-719-107-94	DIODE 1SS202-1
D553	8-719-107-94	DIODE 1SS202-1
D554	8-719-114-29	DIODE RD5.1JS-B1
D701	8-719-107-94	DIODE 1SS202-1
D702	8-719-107-94	DIODE 1SS202-1
D703	8-719-504-60	DIODE S4VB60
D704	8-719-200-77	DIODE 10E2N
D705	8-719-200-77	DIODE 10E2N
D706	8-719-230-02	DIODE 30DF2
D707	8-719-230-02	DIODE 30DF2
D708	8-719-230-02	DIODE 30DF2
D709	8-719-230-02	DIODE 30DF2
D710	8-719-933-41	DIODE HZS6C3L
D711	8-719-107-94	DIODE 1SS202-1
D712	8-719-200-77	DIODE 10E2N
D713	8-719-933-39	DIODE HZS6C1L
D714	8-719-933-39	DIODE HZS6C1L
D716	8-719-934-18	DIODE HZS27-2L
D717	8-719-114-29	DIODE RD5.1JS-B1
D801	8-719-312-76	LED SEL4814A-CD
D802	8-719-304-32	LED SEL4214S
D803	8-719-304-37	LED SEL4414E-C
D804	8-719-107-94	DIODE 1SS202-1
D806	8-719-107-94	DIODE 1SS202-1
D807	8-719-107-94	DIODE 1SS202-1
F701	Δ1-532-285-00	(AEP,WG,UK,E)...FUSE, TIME-LAG (2.5A)
F701	Δ1-532-744-11	(US,Canadian)...FUSE, GLASS TUBE (2.5A)
F702	Δ1-532-285-00	(AEP,WG,UK,E)...FUSE, TIME-LAG (2.5A)
F702	Δ1-532-744-11	(US,Canadian)...FUSE, GLASS TUBE (2.5A)
FLT501	1-519-497-11	INDICATOR TUBE, FLUORESCENT
FLT801	1-519-567-11	INDICATOR TUBE, FLUORESCENT
H901	8-719-403-79	HOLE ELEMENT OH009
H902	8-719-403-79	HOLE ELEMENT OH009
H903	8-719-403-79	HOLE ELEMENT OH009
HE501	1-543-358-11	HEAD, MAGNETIC (ERASE)
HRP501	1-543-684-11	HEAD, MAGNETIC (REC/PB)
IC101	8-759-900-72	IC NE5532P
IC102	8-759-900-72	IC NE5532P
IC201	8-759-900-72	IC NE5532P
IC202	8-759-900-72	IC NE5532P
IC501	8-759-900-72	IC NE5532P
IC503	8-752-018-80	IC CX20188
IC504	8-759-602-83	IC M5238P
IC505	8-752-018-80	IC CX20188
IC506	8-759-900-72	IC NE5532P
IC507	8-759-981-96	IC RC4560D
IC508	8-759-945-58	IC RC4558P
IC509	8-759-982-26	IC RC78L12A
IC510	8-759-982-48	IC RC79L12A
IC511	8-759-602-83	IC M5238P
IC512	8-759-961-38	IC BA6138
IC513	8-759-945-58	IC RC4558P
IC514	8-759-904-72	IC MSL9359RS
IC517	8-759-106-56	IC UPC1297CA

Note:
The components identified by mark Δ or dotted line with mark Δ are critical for safety. Replace only with part number specified.

Note:
Les composants identifiés par une marque Δ sont critiques pour la sécurité. Ne les remplacer que par une pièce portant le numéro spécifié.

Ref.No.	Part No.	Description	Ref.No.	Part No.	Description
IC519	8-759-240-50	IC UPD14050BC	Q203	8-729-141-30	TRANSISTOR 2SC3623A-LK
IC520	8-759-140-11	IC MC14011BCP	Q204	8-729-141-30	TRANSISTOR 2SC3623A-LK
IC701	8-759-604-29	IC MSF7805L	Q205	8-729-141-30	TRANSISTOR 2SC3623A-LK
IC702	8-759-604-33	IC MSF7812L	Q206	8-729-141-30	TRANSISTOR 2SC3623A-LK
IC801	8-759-634-78	IC M50964-222SP	Q207	8-729-217-03	TRANSISTOR 2SK170
IC802	8-759-240-69	IC TC14069UBP	Q208	8-729-217-03	TRANSISTOR 2SK170
IC803	8-759-973-95	IC BA6219B	Q209	8-729-375-61	TRANSISTOR 2SD756
IC804	8-759-973-95	IC BA6219B	Q210	8-729-201-56	TRANSISTOR 2SK246-GR2
IC805	8-749-920-83	IC GP1U52XB	Q211	8-729-194-57	TRANSISTOR 2SC945
IC806	8-759-905-48	IC MSL9512RS	Q213	8-729-141-30	TRANSISTOR 2SC3623A-LK
IC902	8-752-017-40	IC CX20174	Q218	8-729-102-14	TRANSISTOR 2SD1021
IC951	8-759-995-08	IC MC4558	Q501	8-729-167-62	TRANSISTOR 2SC2676
IC952	8-759-201-58	IC TC9142P	Q502	8-729-113-82	TRANSISTOR 2SA1138
IC1001	8-749-920-97	PHOTO REFLECTOR GP2S22B	Q503	8-729-167-62	TRANSISTOR 2SC2676
IC1002	8-749-920-97	PHOTO REFLECTOR GP2S22B	Q504	8-729-113-82	TRANSISTOR 2SA1138
J501	*1-568-250-21	JACK, PIN 2P (LINE OUT)	Q505	8-729-107-53	TRANSISTOR 2SC2275A
J502	1-569-140-11	JACK (LARGE TYPE) (PHONES)	Q506	8-729-190-53	TRANSISTOR 2SA985A
J505	*1-569-186-11	JACK, PIN 4P (LINE IN/CD DIRECT IN)	Q507	8-729-900-89	TRANSISTOR DTC144ES
JR901	1-216-296-00	METAL GLAZE 0 5% 1/8W	Q508	8-729-900-63	TRANSISTOR DTA124ES
JR902	1-216-296-00	METAL GLAZE 0 5% 1/8W	Q509	8-729-900-89	TRANSISTOR DTC144ES
JR903	1-216-296-00	METAL GLAZE 0 5% 1/8W	Q510	8-729-230-45	TRANSISTOR 2SC2458-YGR
JR904	1-216-296-00	METAL GLAZE 0 5% 1/8W	Q511	8-729-900-89	TRANSISTOR DTC144ES
JR905	1-216-296-00	METAL GLAZE 0 5% 1/8W	Q512	8-729-900-36	TRANSISTOR DTC124ES
L103	1-408-920-00	INDUCTOR 4.7MMH	Q513	8-729-900-36	TRANSISTOR DTC124ES
L104	1-408-918-11	INDUCTOR 3.3MMH	Q514	8-729-230-45	TRANSISTOR 2SC2458-YGR
L105	1-408-916-11	INDUCTOR 2.2MMH	Q515	8-729-900-61	TRANSISTOR DTA114ES
L106	1-408-925-11	INDUCTOR 12MMH	Q516	8-729-141-30	TRANSISTOR 2SC3623A-LK
L107	1-408-916-11	INDUCTOR 2.2MMH	Q517	8-729-141-30	TRANSISTOR 2SC3623A-LK
L203	1-408-920-00	INDUCTOR 4.7MMH	Q519	8-729-900-63	TRANSISTOR DTA124ES
L204	1-408-918-11	INDUCTOR 3.3MMH	Q521	8-729-281-53	TRANSISTOR 2SC1815-GR
L205	1-408-916-11	INDUCTOR 2.2MMH	Q522	8-729-201-53	TRANSISTOR 2SA1015-GR
L206	1-408-925-11	INDUCTOR 12MMH	Q523	8-729-900-63	TRANSISTOR DTA124ES
L207	1-408-916-11	INDUCTOR 2.2MMH	Q524	8-729-201-56	TRANSISTOR 2SK246-GR2
L501	1-410-525-11	INDUCTOR 220UH	Q525	8-729-201-56	TRANSISTOR 2SK246-GR2
L502	1-410-525-11	INDUCTOR 220UH	Q526	8-729-900-89	TRANSISTOR DTC144ES
L503	1-410-525-11	INDUCTOR 220UH	Q527	8-729-900-89	TRANSISTOR DTC144ES
LPF101	1-236-087-11	FILTER, LOW PASS	Q528	8-729-900-36	TRANSISTOR DTC124ES
LPF201	1-236-087-11	FILTER, LOW PASS	Q529	8-729-119-76	TRANSISTOR 2SA1175-HFE
M1001	X-3356-604-1	MOTOR (ASSIST) ASSY	Q530	8-729-119-76	TRANSISTOR 2SA1175-HFE
M1002	X-3356-638-1	MOTOR (REEL R) ASSY	Q531	8-729-900-63	TRANSISTOR DTA124ES
PL501	1-518-471-31	LAMP, PILOT	Q532	8-729-281-53	TRANSISTOR 2SC1815-GR
PL502	1-518-471-31	LAMP, PILOT	Q533	8-729-900-63	TRANSISTOR DTA124ES
PS703	1-532-685-00	LINK, IC	Q535	8-729-900-36	TRANSISTOR DTC124ES
PS704	1-532-685-00	LINK, IC	Q536	8-729-900-36	TRANSISTOR DTC124ES
Q101	8-729-141-30	TRANSISTOR 2SC3623A-LK	Q537	8-729-900-36	TRANSISTOR DTC124ES
Q102	8-729-102-14	TRANSISTOR 2SD1021	Q539	8-729-900-36	TRANSISTOR DTC124ES
Q103	8-729-141-30	TRANSISTOR 2SC3623A-LK	Q540	8-729-900-65	TRANSISTOR DTA144ES
Q104	8-729-141-30	TRANSISTOR 2SC3623A-LK	Q541	8-729-900-65	TRANSISTOR DTA144ES
Q105	8-729-141-30	TRANSISTOR 2SC3623A-LK	Q542	8-729-900-65	TRANSISTOR DTA144ES
Q106	8-729-141-30	TRANSISTOR 2SC3623A-LK	Q543	8-729-900-65	TRANSISTOR DTA144ES
Q107	8-729-217-03	TRANSISTOR 2SK170	Q544	8-729-900-61	TRANSISTOR DTA114ES
Q108	8-729-217-03	TRANSISTOR 2SK170	Q545	8-729-900-61	TRANSISTOR DTA114ES
Q109	8-729-375-61	TRANSISTOR 2SD756	Q546	8-729-900-89	TRANSISTOR DTC144ES
Q110	8-729-201-56	TRANSISTOR 2SK246-GR2	Q547	8-729-900-89	TRANSISTOR DTC144ES
Q111	8-729-194-57	TRANSISTOR 2SC945	Q548	8-729-900-89	TRANSISTOR DTC144ES
Q113	8-729-141-30	TRANSISTOR 2SC3623A-LK	Q549	8-729-119-76	TRANSISTOR 2SA1175-HFE
Q118	8-729-102-14	TRANSISTOR 2SD1021	Q551	8-729-119-76	TRANSISTOR 2SA1175-HFE
Q201	8-729-141-30	TRANSISTOR 2SC3623A-LK			
Q202	8-729-102-14	TRANSISTOR 2SD1021			

Ref.No.	Part No.	Description			
Q552	8-729-900-80	TRANSISTOR	DTC114ES		
Q553	8-729-900-80	TRANSISTOR	DTC114ES		
Q554	8-729-900-80	TRANSISTOR	DTC114ES		
Q555	8-729-230-45	TRANSISTOR	2SC2458-YGR		
Q556	8-729-230-45	TRANSISTOR	2SC2458-YGR		
Q557	8-729-230-45	TRANSISTOR	2SC2458-YGR		
Q701	8-729-141-03	TRANSISTOR	2SA733-QP		
Q702	8-729-920-97	TRANSISTOR	2SB1187-EF		
Q703	8-729-194-57	TRANSISTOR	2SC945-P		
Q704	8-729-194-57	TRANSISTOR	2SC945-P		
Q707	8-729-920-98	TRANSISTOR	2SD1761-EF		
Q709	8-729-141-03	TRANSISTOR	2SA733-QP		
Q709	8-729-141-03	TRANSISTOR	2SA733-QP		
Q801	8-729-900-61	TRANSISTOR	DTA114ES		
Q802	8-729-900-61	TRANSISTOR	DTA114ES		
Q803	8-729-900-61	TRANSISTOR	DTA114ES		
Q804	8-729-900-61	TRANSISTOR	DTA114ES		
Q805	8-729-194-57	TRANSISTOR	2SC945-P		
Q806	8-729-141-03	TRANSISTOR	2SA733-QP		
Q807	8-729-194-57	TRANSISTOR	2SC945-P		
Q808	8-729-194-57	TRANSISTOR	2SC945-P		
Q809	8-729-900-65	TRANSISTOR	DTA144ES		
Q810	8-729-900-65	TRANSISTOR	DTA144ES		
Q811	8-729-900-65	TRANSISTOR	DTA144ES		
Q812	8-729-900-65	TRANSISTOR	DTA144ES		
Q813	8-729-900-65	TRANSISTOR	DTA144ES		
R101	1-249-844-11	CARBON	56K	5%	1/2W
R102	1-247-128-00	CARBON	750	5%	1/4W
R103	1-247-128-00	CARBON	750	5%	1/4W
R104	1-247-700-11	CARBON	100	5%	1/4W
R105	1-247-708-11	CARBON	470	5%	1/4W
R106	1-249-518-11	CARBON	39	5%	1/4W
R107	1-249-429-11	CARBON	10K	5%	1/4W
R108	1-247-721-11	CARBON	4.7K	5%	1/4W
R109	1-247-704-11	CARBON	220	5%	1/4W
R110	1-249-723-11	CARBON	120K	5%	1/2W
R111	1-247-749-11	CARBON	560	5%	1/2W
R112	1-247-764-11	CARBON	10K	5%	1/2W
R113	1-247-146-00	CARBON	4.3K	5%	1/4W
R114	1-247-142-00	CARBON	3K	5%	1/4W
R115	1-246-545-00	CARBON	1M	5%	1/4W
R116	1-247-710-11	CARBON	560	5%	1/4W
R117	1-249-462-11	CARBON	22K	5%	1/4W
R118	1-247-152-00	CARBON	7.5K	5%	1/4W
R119	1-247-711-11	CARBON	680	5%	1/4W
R120	1-247-154-00	CARBON	9.1K	5%	1/4W
R121	1-249-465-11	CARBON	47K	5%	1/4W
R122	1-249-586-11	CARBON	27K	5%	1/4W
R123	1-247-152-00	CARBON	8.2K	5%	1/4W
R124	1-249-469-11	CARBON	100K	5%	1/4W
R125	1-247-723-11	CARBON	6.8K	5%	1/4W
R126	1-247-720-11	CARBON	3.9K	5%	1/4W
R127	1-247-719-11	CARBON	3.3K	5%	1/4W

Ref.No.	Part No.	Description			
R128	1-247-152-00	CARBON	7.5K	5%	1/4W
R129	1-249-469-11	CARBON	100K	5%	1/4W
R130	1-247-747-11	CARBON	470	5%	1/2W
R131	1-247-764-11	CARBON	10K	5%	1/2W
R132	1-247-146-00	CARBON	4.3K	5%	1/4W
R133	1-247-142-00	CARBON	3K	5%	1/4W
R134	1-246-545-00	CARBON	1M	5%	1/4W
R135	1-247-710-11	CARBON	560	5%	1/4W
R136	1-249-462-11	CARBON	22K	5%	1/4W
R137	1-247-152-00	CARBON	7.5K	5%	1/4W
R138	1-247-711-11	CARBON	680	5%	1/4W
R139	1-247-154-00	CARBON	9.1K	5%	1/4W
R140	1-249-465-11	CARBON	47K	5%	1/4W
R141	1-247-721-11	CARBON	4.7K	5%	1/4W
R142	1-247-152-00	CARBON	8.2K	5%	1/4W
R143	1-247-725-11	CARBON	10K	5%	1/4W
R144	1-249-462-11	CARBON	22K	5%	1/4W
R145	1-247-721-11	CARBON	4.7K	5%	1/4W
R146	1-246-545-00	CARBON	1M	5%	1/4W
R147	1-247-719-11	CARBON	3.3K	5%	1/4W
R148	1-247-723-11	CARBON	6.8K	5%	1/4W
R149	1-249-425-11	CARBON	4.7K	5%	1/4W
R150	1-249-590-11	CARBON	39K	5%	1/4W
R151	1-249-429-11	CARBON	10K	5%	1/4W
R152	1-249-465-11	CARBON	47K	5%	1/4W
R153	1-247-716-11	CARBON	1.8K	5%	1/4W
R154	1-249-429-11	CARBON	10K	5%	1/4W
R155	1-249-598-11	CARBON	82K	5%	1/4W
R156	1-249-467-11	CARBON	43K	5%	1/4W
R157	1-247-701-11	CARBON	120	5%	1/4W
R158	1-249-459-11	CARBON	12K	5%	1/4W
R159	1-249-429-11	CARBON	10K	5%	1/4W
R160	1-247-701-11	CARBON	120	5%	1/4W
R161	1-247-142-00	CARBON	3K	5%	1/4W
R162	1-247-721-11	CARBON	4.7K	5%	1/4W
R163	1-249-429-11	CARBON	10K	5%	1/4W
R164	1-247-700-11	CARBON	100	5%	1/4W
R165	1-247-718-11	CARBON	2.7K	5%	1/4W
R166	1-247-719-11	CARBON	3.3K	5%	1/4W
R167	1-249-429-11	CARBON	10K	5%	1/4W
R168	1-247-718-11	CARBON	2.7K	5%	1/4W
R169	1-247-714-11	CARBON	1.2K	5%	1/4W
R170	1-247-714-11	CARBON	1.2K	5%	1/4W
R171	1-249-465-11	CARBON	47K	5%	1/4W
R172	1-247-721-11	CARBON	4.7K	5%	1/4W
R173	1-249-461-11	CARBON	18K	5%	1/4W
R174	1-249-469-11	CARBON	100K	5%	1/4W
R175	1-247-704-11	CARBON	220	5%	1/4W
R176	1-247-710-11	CARBON	560	5%	1/4W
R177	1-249-421-11	CARBON	2.2K	5%	1/4W
R178	1-249-397-11	CARBON	22	5%	1/4W
R179	1-247-383-00	CARBON	150K	5%	1/4W
R180	1-249-429-11	CARBON	10K	5%	1/4W
R181	1-249-417-11	CARBON	1K	5%	1/4W
R182	1-249-437-11	CARBON	47K	5%	1/4W
R183	1-249-417-11	CARBON	1K	5%	1/4W
R184	1-249-429-11	CARBON	10K	5%	1/4W

Ref.No.	Part No.	Description			
R185	1-249-441-11	CARBON	100K	5%	1/4W
R187	1-249-462-11	CARBON	22K	5%	1/4W
R188	1-247-740-11	CARBON	120	5%	1/2W
R189	1-247-255-00	CARBON	4.3K	5%	1/2W
R190	1-249-658-11	CARBON	240	5%	1/2W
R191	1-214-851-00	CARBON	300	5%	1/2W
R192	1-247-764-11	CARBON	10K	5%	1/2W
R193	1-247-720-11	CARBON	3.9K	5%	1/4W
R194	1-247-718-11	CARBON	2.7K	5%	1/4W
R195	1-247-718-11	CARBON	2.7K	5%	1/4W
R196	1-247-721-11	CARBON	4.7K	5%	1/4W
R197	1-247-146-00	CARBON	4.3K	5%	1/4W
R198	1-247-718-11	CARBON	2.7K	5%	1/4W
R199	1-247-718-11	CARBON	2.7K	5%	1/4W
R201	1-249-844-11	CARBON	56K	5%	1/2W
R202	1-247-128-00	CARBON	750	5%	1/4W
R203	1-247-128-00	CARBON	750	5%	1/4W
R204	1-247-700-11	CARBON	100	5%	1/4W
R205	1-247-708-11	CARBON	470	5%	1/4W
R206	1-249-518-11	CARBON	39	5%	1/4W
R207	1-249-429-11	CARBON	10K	5%	1/4W
R208	1-247-721-11	CARBON	4.7K	5%	1/4W
R209	1-247-704-11	CARBON	220	5%	1/4W
R210	1-249-723-11	CARBON	120K	5%	1/2W
R211	1-247-749-11	CARBON	560	5%	1/2W
R212	1-247-764-11	CARBON	10K	5%	1/2W
R213	1-247-146-00	CARBON	4.3K	5%	1/4W
R214	1-247-142-00	CARBON	3K	5%	1/4W
R215	1-246-545-00	CARBON	1M	5%	1/4W
R216	1-247-710-11	CARBON	560	5%	1/4W
R217	1-249-462-11	CARBON	22K	5%	1/4W
R218	1-247-152-00	CARBON	7.5K	5%	1/4W
R219	1-247-711-11	CARBON	680	5%	1/4W
R220	1-247-154-00	CARBON	9.1K	5%	1/4W
R221	1-249-465-11	CARBON	47K	5%	1/4W
R222	1-249-586-11	CARBON	27K	5%	1/4W
R223	1-247-152-00	CARBON	8.2K	5%	1/4W
R224	1-249-469-11	CARBON	100K	5%	1/4W
R225	1-247-723-11	CARBON	6.8K	5%	1/4W
R226	1-247-720-11	CARBON	3.9K	5%	1/4W
R227	1-247-719-11	CARBON	3.3K	5%	1/4W
R228	1-247-152-00	CARBON	7.5K	5%	1/4W
R229	1-249-469-11	CARBON	100K	5%	1/4W
R230	1-247-747-11	CARBON	470	5%	1/2W
R231	1-247-764-11	CARBON	10K	5%	1/2W
R232	1-247-146-00	CARBON	4.3K	5%	1/4W
R233	1-247-142-00	CARBON	3K	5%	1/4W
R234	1-246-545-00	CARBON	1M	5%	1/4W
R235	1-247-710-11	CARBON	560	5%	1/4W
R236	1-249-462-11	CARBON	22K	5%	1/4W
R237	1-247-152-00	CARBON	7.5K	5%	1/4W
R238	1-247-711-11	CARBON	680	5%	1/4W
R239	1-247-154-00	CARBON	9.1K	5%	1/4W
R240	1-249-465-11	CARBON	47K	5%	1/4W
R241	1-247-721-11	CARBON	4.7K	5%	1/4W
R242	1-247-152-00	CARBON	8.2K	5%	1/4W
R243	1-247-725-11	CARBON	10K	5%	1/4W



Ref.No.	Part No.	Description			
R244	1-249-462-11	CARBON	22K	5%	1/4W
R245	1-247-721-11	CARBON	4.7K	5%	1/4W
R246	1-246-545-00	CARBON	1M	5%	1/4W
R247	1-247-719-11	CARBON	3.3K	5%	1/4W
R248	1-247-723-11	CARBON	6.8K	5%	1/4W
R249	1-249-425-11	CARBON	4.7K	5%	1/4W
R250	1-249-590-11	CARBON	39K	5%	1/4W
R251	1-249-429-11	CARBON	10K	5%	1/4W
R252	1-249-465-11	CARBON	47K	5%	1/4W
R253	1-247-716-11	CARBON	1.8K	5%	1/4W
R254	1-249-429-11	CARBON	10K	5%	1/4W
R255	1-249-598-11	CARBON	82K	5%	1/4W
R256	1-259-467-11	CARBON	43K	5%	1/4W
R257	1-247-701-11	CARBON	120	5%	1/4W
R258	1-249-459-11	CARBON	12K	5%	1/4W
R259	1-249-429-11	CARBON	10K	5%	1/4W
R260	1-247-701-11	CARBON	120	5%	1/4W
R261	1-247-142-00	CARBON	3K	5%	1/4W
R262	1-247-721-11	CARBON	4.7K	5%	1/4W
R263	1-249-429-11	CARBON	10K	5%	1/4W
R264	1-247-700-11	CARBON	100	5%	1/4W
R265	1-247-718-11	CARBON	2.7K	5%	1/4W
R266	1-247-719-11	CARBON	3.3K	5%	1/4W
R267	1-249-429-11	CARBON	10K	5%	1/4W
R268	1-247-718-11	CARBON	2.7K	5%	1/4W
R269	1-247-714-11	CARBON	1.2K	5%	1/4W
R270	1-247-714-11	CARBON	1.2K	5%	1/4W
R271	1-249-465-11	CARBON	47K	5%	1/4W
R272	1-247-721-11	CARBON	4.7K	5%	1/4W
R273	1-249-461-11	CARBON	18K	5%	1/4W
R274	1-249-469-11	CARBON	100K	5%	1/4W
R275	1-247-704-11	CARBON	220	5%	1/4W
R276	1-247-710-11	CARBON	560	5%	1/4W
R277	1-249-421-11	CARBON	2.2K	5%	1/4W
R278	1-249-397-11	CARBON	22	5%	1/4W
R279	1-247-883-00	CARBON	150K	5%	1/4W
R280	1-249-429-11	CARBON	10K	5%	1/4W
R281	1-249-417-11	CARBON	1K	5%	1/4W
R282	1-249-437-11	CARBON	47K	5%	1/4W
R283	1-249-417-11	CARBON	1K	5%	1/4W
R284	1-249-429-11	CARBON	10K	5%	1/4W
R285	1-249-441-11	CARBON	100K	5%	1/4W
R287	1-249-462-11	CARBON	22K	5%	1/4W
R288	1-247-740-11	CARBON	120	5%	1/2W
R289	1-247-255-00	CARBON	4.3K	5%	1/2W
R290	1-249-658-11	CARBON	240	5%	1/2W
R291	1-214-851-00	CARBON	300	5%	1/2W
R292	1-247-764-11	CARBON	10K	5%	1/2W
R293	1-247-720-11	CARBON	3.9K	5%	1/4W
R294	1-247-718-11	CARBON	2.7K	5%	1/4W
R295	1-247-718-11	CARBON	2.7K	5%	1/4W
R296	1-247-721-11	CARBON	4.7K	5%	1/4W
R297	1-247-146-00	CARBON	4.3K	5%	1/4W
R298	1-247-718-11	CARBON	2.7K	5%	1/4W
R299	1-247-718-11	CARBON	2.7K	5%	1/4W
R301	1-247-719-11	CARBON	3.3K	5%	1/4W
R302	1-249-926-11	CARBON	1.3K	5%	1/4W

Ref.No.	Part No.	Description			
R303	1-247-891-00	CARBON	330K	5%	1/4W
R304	1-249-604-11	CARBON	150K	5%	1/4W
R307	1-247-883-00	CARBON	150K	5%	1/4W
R308	1-249-426-11	CARBON	5.6K	5%	1/4W
R312	1-247-725-11	CARBON	10K	5%	1/4W
R315	1-246-545-00	CARBON	1M	5%	1/4W
R316	1-246-545-00	CARBON	1M	5%	1/4W
R317	1-247-842-11	CARBON	3K	5%	1/4W
R318	1-249-425-11	CARBON	4.7K	5%	1/4W
R401	1-247-719-11	CARBON	3.3K	5%	1/4W
R402	1-249-926-11	CARBON	1.3K	5%	1/4W
R403	1-247-391-00	CARBON	330K	5%	1/4W
R404	1-249-604-11	CARBON	150K	5%	1/4W
R407	1-247-883-00	CARBON	150K	5%	1/4W
R408	1-249-426-11	CARBON	5.6K	5%	1/4W
R412	1-247-725-11	CARBON	10K	5%	1/4W
R415	1-246-545-00	CARBON	1M	5%	1/4W
R416	1-246-545-00	CARBON	1M	5%	1/4W
R417	1-247-842-11	CARBON	3K	5%	1/4W
R418	1-249-425-11	CARBON	4.7K	5%	1/4W
R501	1-249-466-11	CARBON	56K	5%	1/4W
R502	1-249-466-11	CARBON	56K	5%	1/4W
R503	1-247-719-11	CARBON	3.3K	5%	1/4W
R504	1-247-719-11	CARBON	3.3K	5%	1/4W
R505	1-247-749-11	CARBON	560	5%	1/2W
R506	1-247-749-11	CARBON	560	5%	1/2W
R507	1-249-673-11	CARBON	1K	5%	1/2W
R508	1-249-673-11	CARBON	1K	5%	1/2W
R509	1-249-429-11	CARBON	10K	5%	1/4W
R510	1-215-472-00	METAL	130K	1%	1/6W
R511	1-249-433-11	CARBON	22K	5%	1/4W
R512	1-249-437-11	CARBON	47K	5%	1/4W
R513	1-249-425-11	CARBON	4.7K	5%	1/4W
R514	1-249-434-11	CARBON	27K	5%	1/4W
R515	1-249-429-11	CARBON	10K	5%	1/4W
R516	1-249-433-11	CARBON	22K	5%	1/4W
R517	1-249-437-11	CARBON	47K	5%	1/4W
R518	1-249-429-11	CARBON	10K	5%	1/4W
R519	1-215-472-00	METAL	130K	1%	1/6W
R520	1-247-700-11	CARBON	100	5%	1/4W
R521	1-247-700-11	CARBON	100	5%	1/4W
R522	1-249-433-11	CARBON	22K	5%	1/4W
R523	1-249-417-11	CARBON	1K	5%	1/4W
R524	1-249-435-11	CARBON	33K	5%	1/4W
R525	1-249-438-11	CARBON	56K	5%	1/4W
R526	1-249-429-11	CARBON	10K	5%	1/4W
R527	1-249-429-11	CARBON	10K	5%	1/4W
R528	1-249-437-11	CARBON	47K	5%	1/4W
R529	1-249-421-11	CARBON	2.2K	5%	1/4W
R530	1-249-438-11	CARBON	56K	5%	1/4W
R531	1-249-433-11	CARBON	22K	5%	1/4W
R533	1-249-433-11	CARBON	22K	5%	1/4W
R536	1-249-433-11	CARBON	22K	5%	1/4W
R537	1-247-878-00	CARBON	91K	5%	1/4W
R538	1-249-434-11	CARBON	27K	5%	1/4W
R539	1-249-433-11	CARBON	22K	5%	1/4W
R540	1-249-438-11	CARBON	56K	5%	1/4W

Ref.No.	Part No.	Description			
R541	1-249-429-11	CARBON	10K	5%	1/4W
R542	1-249-433-11	CARBON	22K	5%	1/4W
R543	1-249-437-11	CARBON	47K	5%	1/4W
R544	1-247-818-11	CARBON	300	5%	1/4W
R545	1-247-818-11	CARBON	300	5%	1/4W
R546	1-249-433-11	CARBON	22K	5%	1/4W
R547	1-249-425-11	CARBON	4.7K	5%	1/4W
R548	1-249-433-11	CARBON	22K	5%	1/4W
R550	1-249-429-11	CARBON	10K	5%	1/4W
R551	1-249-437-11	CARBON	47K	5%	1/4W
R552	1-249-428-11	CARBON	8.2K	5%	1/4W
R553	1-249-397-11	CARBON	22	5%	1/4W
R554	1-247-856-00	CARBON	11K	5%	1/4W
R555	1-247-856-00	CARBON	11K	5%	1/4W
R556	1-249-407-11	CARBON	150	5%	1/4W
R557	1-249-428-11	CARBON	8.2K	5%	1/4W
R558	1-249-397-11	CARBON	22	5%	1/4W
R559	1-249-432-11	CARBON	18K	5%	1/4W
R560	1-249-432-11	CARBON	18K	5%	1/4W
R561	1-249-407-11	CARBON	150	5%	1/4W
R562	1-247-887-00	CARBON	220K	5%	1/4W
R563	1-247-887-00	CARBON	220K	5%	1/4W
R564	1-249-433-11	CARBON	22K	5%	1/4W
R565	1-249-433-11	CARBON	22K	5%	1/4W
R566	1-249-441-11	CARBON	100K	5%	1/4W
R567	1-249-441-11	CARBON	100K	5%	1/4W
R568	1-249-441-11	CARBON	100K	5%	1/4W
R569	1-249-441-11	CARBON	100K	5%	1/4W
R570	1-249-441-11	CARBON	100K	5%	1/4W
R571	1-249-441-11	CARBON	100K	5%	1/4W
R572	1-249-441-11	CARBON	100K	5%	1/4W
R573	1-249-441-11	CARBON	100K	5%	1/4W
R574	1-249-441-11	CARBON	100K	5%	1/4W
R575	1-249-441-11	CARBON	100K	5%	1/4W
R576	1-249-441-11	CARBON	100K	5%	1/4W
R577	1-249-441-11	CARBON	100K	5%	1/4W
R578	1-249-441-11	CARBON	100K	5%	1/4W
R579	1-249-441-11	CARBON	100K	5%	1/4W
R580	1-249-410-11	CARBON	270	5%	1/4W
R581	1-249-410-11	CARBON	270	5%	1/4W
R582	1-247-887-00	CARBON	220K	5%	1/4W
R583	1-249-432-11	CARBON	18K	5%	1/4W
R584	1-249-429-11	CARBON	10K	5%	1/4W
R585	1-249-429-11	CARBON	10K	5%	1/4W
R586	1-249-408-11	CARBON	180	5%	1/4W
R587	1-249-421-11	CARBON	2.2K	5%	1/4W
R591	1-249-417-11	CARBON	1K	5%	1/4W
R592	1-247-862-11	CARBON	20K	5%	1/4W
R593	1-247-860-11	CARBON	16K	5%	1/4W
R594	1-249-405-11	CARBON	100	5%	1/4W
R595	1-249-405-11	CARBON	100	5%	1/4W
R596	1-249-405-11	CARBON	100	5%	1/4W
R597	1-249-405-11	CARBON	100	5%	1/4W
R598	1-249-405-11	CARBON	100	5%	1/4W
R599	1-249-405-11	CARBON	100	5%	1/4W
R600	1-249-405-11	CARBON	100	5%	1/4W
R601	1-249-405-11	CARBON	100	5%	1/4W

Ref.No.	Part No.	Description			
R602	1-249-405-11	CARBON	100	5%	1/4W
R603	1-249-405-11	CARBON	100	5%	1/4W
R604	1-249-405-11	CARBON	100	5%	1/4W
R605	1-249-429-11	CARBON	10K	5%	1/4W
R606	1-249-441-11	CARBON	100K	5%	1/4W
R607	1-249-410-11	CARBON	270	5%	1/4W
R608	1-249-410-11	CARBON	270	5%	1/4W
R609	1-249-405-11	CARBON	100	5%	1/4W
R611	1-249-547-11	CARBON	620	5%	1/4W
R613	1-249-547-11	CARBON	620	5%	1/4W
R614	1-249-417-11	CARBON	1K	5%	1/4W
R615	1-249-414-11	CARBON	560	5%	1/4W
R616	1-249-426-11	CARBON	5.6K	5%	1/4W
R617	1-249-433-11	CARBON	22K	5%	1/4W
R618	1-247-842-11	CARBON	3K	5%	1/4W
R619	1-247-812-11	CARBON	160	5%	1/4W
R620	1-249-414-11	CARBON	560	5%	1/4W
R621	1-249-417-11	CARBON	1K	5%	1/4W
R622	1-249-429-11	CARBON	10K	5%	1/4W
R623	1-249-429-11	CARBON	10K	5%	1/4W
R624	1-249-417-11	CARBON	1K	5%	1/4W
R625	1-249-433-11	CARBON	22K	5%	1/4W
R626	1-249-424-11	CARBON	3.9K	5%	1/4W
R627	1-249-417-11	CARBON	1K	5%	1/4W
R628	1-249-429-11	CARBON	10K	5%	1/4W
R629	1-249-429-11	CARBON	10K	5%	1/4W
R630	1-249-429-11	CARBON	10K	5%	1/4W
R701	1-247-752-11	CARBON	1K	5%	1/2W
R702	△ 1-212-863-00	FUSIBLE	18	5%	1/4W F
R703	1-249-397-11	CARBON	22	5%	1/4W
R704	1-249-397-11	CARBON	22	5%	1/4W
R705	1-249-425-11	CARBON	4.7K	5%	1/4W
R706	1-249-437-11	CARBON	47K	5%	1/4W
R707	1-249-425-11	CARBON	4.7K	5%	1/4W
R708	1-249-437-11	CARBON	47K	5%	1/4W
R709	1-249-422-11	CARBON	2.7K	5%	1/4W
R710	1-249-427-11	CARBON	6.8K	5%	1/4W
R711	1-249-412-11	CARBON	390	5%	1/4W
R712	1-249-426-11	CARBON	5.6K	5%	1/4W
R713	1-247-956-00	CARBON	11K	5%	1/4W
R714	1-249-425-11	CARBON	4.7K	5%	1/4W
R715	1-249-425-11	CARBON	4.7K	5%	1/4W
R716	1-249-437-11	CARBON	47K	5%	1/4W
R717	1-249-429-11	CARBON	10K	5%	1/4W
R719	1-249-437-11	CARBON	47K	5%	1/4W
R720	1-249-437-11	CARBON	47K	5%	1/4W
R722	1-249-421-11	CARBON	2.2K	5%	1/4W
R801	1-249-422-11	CARBON	2.7K	5%	1/4W
R802	1-249-424-11	CARBON	3.9K	5%	1/4W
R803	1-249-422-11	CARBON	2.7K	5%	1/4W
R804	1-249-424-11	CARBON	3.9K	5%	1/4W
R805	1-249-428-11	CARBON	8.2K	5%	1/4W
R806	1-249-434-11	CARBON	27K	5%	1/4W
R807	1-249-422-11	CARBON	2.7K	5%	1/4W
R808	1-249-424-11	CARBON	3.9K	5%	1/4W
R809	1-249-428-11	CARBON	8.2K	5%	1/4W
R810	1-249-434-11	CARBON	27K	5%	1/4W
R811	1-249-412-11	CARBON	390	5%	1/4W

Ref.No.	Part No.	Description			
R812	1-249-413-11	CARBON	470	5%	1/4W
R813	1-249-410-11	CARBON	270	5%	1/4W
R814	1-249-429-11	CARBON	10K	5%	1/4W
R815	1-249-429-11	CARBON	10K	5%	1/4W
R816	1-249-429-11	CARBON	10K	5%	1/4W
R817	1-249-429-11	CARBON	10K	5%	1/4W
R818	1-249-405-11	CARBON	100	5%	1/4W
R819	1-249-429-11	CARBON	10K	5%	1/4W
R820	1-249-405-11	CARBON	100	5%	1/4W
R821	1-249-429-11	CARBON	10K	5%	1/4W
R822	1-247-903-00	CARBON	1M	5%	1/4W
R823	1-249-441-11	CARBON	100K	5%	1/4W
R824	1-249-433-11	CARBON	22K	5%	1/4W
R825	1-249-425-11	CARBON	4.7K	5%	1/4W
R826	1-249-441-11	CARBON	100K	5%	1/4W
R827	1-249-429-11	CARBON	10K	5%	1/4W
R828	1-249-405-11	CARBON	100	5%	1/4W
R829	1-249-429-11	CARBON	10K	5%	1/4W
R830	1-249-405-11	CARBON	100	5%	1/4W
R831	1-249-429-11	CARBON	10K	5%	1/4W
R832	1-249-405-11	CARBON	100	5%	1/4W
R833	1-249-429-11	CARBON	10K	5%	1/4W
R834	1-249-405-11	CARBON	100	5%	1/4W
R835	1-249-429-11	CARBON	10K	5%	1/4W
R836	1-249-405-11	CARBON	100	5%	1/4W
R837	1-249-429-11	CARBON	10K	5%	1/4W
R838	1-249-405-11	CARBON	100	5%	1/4W
R839	1-249-429-11	CARBON	10K	5%	1/4W
R840	1-249-405-11	CARBON	100	5%	1/4W
R841	1-249-429-11	CARBON	10K	5%	1/4W
R842	1-249-405-11	CARBON	100	5%	1/4W
R843	1-249-425-11	CARBON	4.7K	5%	1/4W
R844	1-249-429-11	CARBON	10K	5%	1/4W
R845	1-249-426-11	CARBON	5.6K	5%	1/4W
R846	1-249-426-11	CARBON	5.6K	5%	1/4W
R847	1-249-426-11	CARBON	5.6K	5%	1/4W
R849	1-249-426-11	CARBON	5.6K	5%	1/4W
R850	1-249-426-11	CARBON	5.6K	5%	1/4W
R852	1-249-441-11	CARBON	100K	5%	1/4W
R853	1-249-441-11	CARBON	100K	5%	1/4W
R854	1-249-441-11	CARBON	100K	5%	1/4W
R855	1-249-441-11	CARBON	100K	5%	1/4W
R856	1-249-441-11	CARBON	100K	5%	1/4W
R857	1-249-436-11	CARBON	39K	5%	1/4W
R858	1-247-891-00	CARBON	330K	5%	1/4W
R859	1-249-436-11	CARBON	39K	5%	1/4W
R860	1-247-891-00	CARBON	330K	5%	1/4W
R861	1-249-405-11	CARBON	100	5%	1/4W
R862	1-249-405-11	CARBON	100	5%	1/4W
R863	1-249-405-11	CARBON	100	5%	1/4W
R864	1-249-405-11	CARBON	100	5%	1/4W
R865	1-249-405-11	CARBON	100	5%	1/4W
R866	1-249-405-11	CARBON	100	5%	1/4W
R867	1-249-405-11	CARBON	100	5%	1/4W
R868	1-249-405-11	CARBON	100	5%	1/4W
R869	1-249-405-11	CARBON	100	5%	1/4W
R870	1-249-405-11	CARBON	100	5%	1/4W

Note:
The components identified by mark  or dotted line with mark  are critical for safety. Replace only with part number specified.

Note:
Les composants identifiés par une marque  sont critiques pour la sécurité. Ne les remplacer que par une pièce portant le numéro spécifié.

Ref.No.	Part No.	Description
R871	1-249-429-11	CARBON 10K 5% 1/4W
R872	1-249-429-11	CARBON 10K 5% 1/4W
R873	1-249-426-11	CARBON 5.6K 5% 1/4W
R874	1-249-426-11	CARBON 5.6K 5% 1/4W
R875	1-249-429-11	CARBON 10K 5% 1/4W
R876	1-249-429-11	CARBON 10K 5% 1/4W
R877	1-249-429-11	CARBON 10K 5% 1/4W
R907	1-216-242-00	METAL GLAZE 68K 5% 1/8W
R908	1-216-246-00	METAL GLAZE 100K 5% 1/8W
R909	1-216-246-00	METAL GLAZE 100K 5% 1/8W
R910	1-216-238-00	METAL GLAZE 47K 5% 1/8W
R911	1-216-182-00	METAL GLAZE 220 5% 1/8W
R912	1-216-182-00	METAL GLAZE 220 5% 1/8W
R913	1-216-150-00	METAL GLAZE 10 5% 1/8W
R914	1-216-150-00	METAL GLAZE 10 5% 1/8W
R915	1-216-150-00	METAL GLAZE 10 5% 1/8W
R951	1-249-413-11	CARBON 470 5% 1/4W
R952	1-249-413-11	CARBON 470 5% 1/4W
R953	1-247-881-00	CARBON 120K 5% 1/4W
R954	1-247-881-00	CARBON 120K 5% 1/4W
R955	1-249-429-11	CARBON 10K 5% 1/4W
R956	1-249-417-11	CARBON 1K 5% 1/4W
R957	1-249-417-11	CARBON 1K 5% 1/4W
R958	1-247-891-00	CARBON 330K 5% 1/4W
R959	1-247-901-11	CARBON 820K 5% 1/4W
R960	1-249-441-11	CARBON 100K 5% 1/4W
R1001	1-249-408-11	CARBON 180 5% 1/4W
R1002	1-249-408-11	CARBON 180 5% 1/4W
R1051	1-249-412-11	CARBON 390 5% 1/4W
RV101	1-224-550-21	RES, ADJ, METAL GLAZE 220(PB LEVEL ADJ)
RV102	1-224-251-XX	RES, ADJ, METAL GLAZE 4.7K (REC LEVEL ADJ)
RV103	1-237-459-11	RES, ADJ, CARBON 10K (METER ADJ)
RV104	1-237-459-11	RES, ADJ, CARBON 10K (CAL METER ADJ)
RV105	1-237-459-11	RES, ADJ, CARBON 10K (CrO2 BIAS ADJ)
RV108	1-237-456-11	RES, ADJ, CARBON 1K (OA ADJ)
RV201	1-224-550-21	RES, ADJ, METAL GLAZE 220(PB LEVEL ADJ)
RV202	1-224-251-XX	RES, ADJ, METAL GLAZE 4.7K (REC LEVEL ADJ)
RV203	1-237-459-11	RES, ADJ, CARBON 10K (METER ADJ)
RV204	1-237-459-11	RES, ADJ, CARBON 10K (CAL METER ADJ)
RV205	1-237-459-11	RES, ADJ, CARBON 10K (CrO2 BIAS ADJ)
RV208	1-237-456-11	RES, ADJ, CARBON 1K (OA ADJ)
RV501	1-230-344-11	RES, VAR, CARBON 20K/20K (REC LEVEL)
RV502	1-238-840-11	RES, VAR, CARBON 5K/5K (CAL/REC LEVEL)
RV503	1-238-841-11	RES, VAR, CARBON 20K/20K (PHONE LEVEL)
RV504	1-238-839-11	RES, VAR, CARBON 5K (BIAS)
RV507	1-237-873-11	RES, ADJ, CARBON 100 (CAL ADJ)
RV508	1-237-873-11	RES, ADJ, CARBON 100 (CAL ADJ)
RV509	1-237-456-11	RES, ADJ, CARBON 1K (NORMAL BIAS ADJ)
RV510	1-237-459-11	RES, ADJ, CARBON 10K (METEL BIAS ADJ)
RV801	1-237-457-21	RES, ADJ, CARBON 2K (TORQUE ADJ)
RY501	1-515-614-11	RELAY
S001	△1-554-920-11	SWITCH, PUSH (AC POWER)(1 KEY)
S002	△1-570-307-11	(E)...SWITCH, VOLTAGE CHANGE
S501	1-572-163-11	SWITCH, ROTARY (MONITOR)
S502	1-572-162-11	SWITCH, ROTARY (DOLBY NR)
S503	1-572-164-11	SWITCH, ROTARY (REC EQ CAL)

Ref.No.	Part No.	Description
S504	1-572-165-11	SWITCH, PUSH (1 KEY)(HX PRO)
S505	1-554-833-11	SWITCH, PUSH (1 KEY)(CALIBRATION)
S506	1-572-163-11	SWITCH, ROTARY (INPUT)
S801	1-554-303-21	SWITCH, KEY BOARD (RESET)
S802	1-554-303-21	SWITCH, KEY BOARD (MEMORY)
S803	1-554-303-21	SWITCH, KEY BOARD (DISPLAY MODE)
S804	1-554-303-21	SWITCH, KEY BOARD (▲)
S805	1-554-303-21	SWITCH, KEY BOARD (STOP)
S806	1-554-303-21	SWITCH, KEY BOARD (▶▶)
S807	1-554-303-21	SWITCH, KEY BOARD (▶▶)
S808	1-554-303-21	SWITCH, KEY BOARD (REC)
S809	1-554-303-21	SWITCH, KEY BOARD (▶)
S810	1-554-303-21	SWITCH, KEY BOARD (PAUSE)
S811	1-554-303-21	SWITCH, KEY BOARD (◀◀)
S812	1-554-303-21	SWITCH, KEY BOARD (▶▶)
S813	1-554-303-21	SWITCH, KEY BOARD (REC MUTE)
S814	1-571-908-11	SWITCH, SLIDE (TIMER)
S1001	1-466-238-11	ENCODER, ROTARY
S1002	1-570-953-11	SWITCH, PUSH (1 KEY)(DOOR)
S1003	1-571-958-11	SWITCH, PUSH (1 KEY)(CLOSE)
S1004	1-572-126-11	SWITCH, PUSH (1 KEY)(OPEN)
S1005	1-572-125-11	SWITCH, LEAF (FWD)
S1006	1-572-202-11	SWITCH, LEAF (HALF)
S1007	1-572-125-11	SWITCH, LEAF (METAL)
S1008	1-572-125-11	SWITCH, LEAF (70U)
T001	△1-449-981-11	(US,Canadian)...TRANSFORMER, POWER
T001	△1-449-982-11	(AEP,WG).....TRANSFORMER, POWER
T001	△1-449-983-11	(UK).....TRANSFORMER, POWER
T001	△1-449-984-11	(E).....TRANSFORMER, POWER
T101	1-433-361-11	TRANSFORMER, BIAS OSCILLATION
T201	1-433-361-11	TRANSFORMER, BIAS OSCILLATION
THP501	△1-202-856-00	SOLID 22 1/4W F
TP1	*1-535-115-00	TERMINAL
TP801	*1-564-505-11	PLUG, CONNECTOR 2P
X801	1-577-358-21	VIBRATOR, CERAMIC
X951	1-577-615-11	VIBRATOR, CRYSTAL (4.934MHZ)

ACCESSORY & PACKING MATERIAL

1-465-325-11	(UK,E)...REMOTE COMMANDER (RM-J702)
2-181-754-01	(UK,E)...COVER, BATTERY
1-551-734-11	CORD, CONNECTION (RK-74A)
*3-350-465-01	CUSHION
*3-356-964-01	(K333ESG)...INDIVIDUAL CARTON
*3-356-966-01	(K950ES)...INDIVIDUAL CARTON
*3-703-456-01	LABEL, AMS LICENSE
*3-703-710-41	STICKER, SONY SYMBOL (12)
3-751-126-11	(Canadian,AEP,UK,E)...MANUAL, INSTRUCTION
3-751-126-21	(US).....MANUAL, INSTRUCTION
3-751-126-41	(AEP,WG).....MANUAL, INSTRUCTION
3-703-450-01	(US)...INSTRUCTION
3-793-481-13	INSTRUCTION
4-847-802-00	(EXCEPT UK)...SCREW (CASE)

Note:
The components identified by mark Δ or dotted line with mark Δ are critical for safety. Replace only with part number specified.

Note:
Les composants identifiés par une marque Δ sont critiques pour la sécurité. Ne les remplacer que par une pièce portant le numéro spécifié.