

TC-K6 (Panel: Silver)
 AEP Model
 E Model
 US Model
 Canadian Model
 TC-K6B (Panel: Black)
 AEP Model

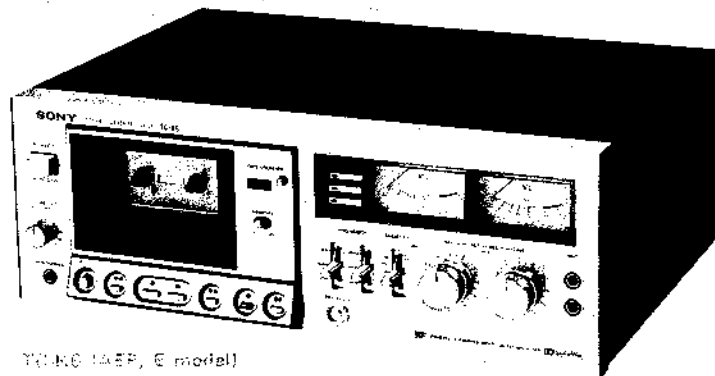

TC-K6 (AEP, E model)

STEREO CASSETTE DECK

SPECIFICATIONS

GENERAL

Power Requirements: 120V ac, 60 Hz (US, Canadian model)
 110, 120, 220, 240V ac, 50/60 Hz
 (AEP, E model)

Power Consumption: 17W ac (US, Canadian model)
 19W ac (AEP, E model)

Dimensions: (US, Canadian model)
 Approx. 460 (w) x 170 (h) x 310 (d) mm
 18 1/8 (w) x 6 3/4 (h) x 12 1/4 (d) inches
 (AEP, E model)
 Approx. 430 (w) x 170 (h) x 310 (d) mm
 17 (w) x 6 3/4 (h) x 12 1/4 (d) inches
 including projecting parts and controls

Weight: 9.5 kg, 20 lb 15 oz (US, Canadian model)
 8.5 kg, 18 lb 12 oz (AEP, E model)

Frequency Response:

DOLBY NR OFF

With Ferri-Chrome cassette
 20-18,000 Hz (NAB)
 30-16,000 Hz ±3 dB (NAB)
 30-16,000 Hz (DIN)
 With chromium dioxide cassette
 20-17,000 Hz (NAB)
 30-15,000 Hz ±3 dB (NAB)
 30-15,000 Hz (DIN)
 With standard cassette
 20-15,000 Hz (NAB)
 30-15,000 Hz (DIN)

Wow and Flutter:

0.05% WRMS (NAB)
 ±0.14% (DIN)

SN Ratio:

DOLBY NR OFF

With Ferri-Chrome cassette
 59 dB at peak level (NAB)
 57 dB (DIN, 1975 rev.)
 With chromium dioxide cassette
 55 dB at peak level (NAB)

DOLBY NR ON

Improved by 5 dB at 1 kHz,
 10 dB above 5 kHz

TAPE RECORDER SECTION

Track: 4-track 2-channel stereo

Fast Forward

Rewind Time: Approx. 90 seconds with Sony cassette C-60

'Dolby' and the double-D symbol are the trade marks of Dolby Laboratory Inc. Noise reduction system manufactured under license from Dolby Laboratory Inc.

REPAIRABLE BY COMPONENT METHOD

COMPONENTS IDENTIFIED BY NUMBERS AND A
 REFERENCE TO THE SCHEMATIC DIAGRAMS ENCLOSED
 WITH THIS MANUAL. THESE COMPONENTS ARE CRITICAL TO
 PROPER OPERATION. REPLACE THESE COMPONENTS
 WITH SONY PARTS WHOSE PART NUMBERS APPEAR
 AS SHOWN IN THIS MANUAL OR IN SUPPLEMENTS
 APPROVED BY SONY.

- Continued on page 2 -

SONY
SERVICE MANUAL

TC-K6/K6B

Total Harmonic Distortion: 1.3%

Record Bias Frequency: 105 kHz

Inputs: MIC (phone jacks) 2
sensitivity 0.25 mV (-70 dB)
for a low-impedance microphone

LINE IN (phono jacks) 2
sensitivity 77.5 mV (-20 dB)
input impedance 100 k Ω

Outputs: VARIABLE LINE OUTPUT
(phono jacks) 2
output level 0.775 V (0 dB)
at load impedance 100 k Ω
with LINE OUT level control at "10"
suitable load impedance more than
10 k Ω

FIXED LINE OUTPUT (phono jacks) . 2
output level 0.435 V (-5 dB)
at load impedance 100 k Ω
suitable load impedance more than
10 k Ω

HEADPHONES 1
output level -20 to -50 dB
at load impedance 8 Ω

REC/PB Jack (DIN): Input impedance less than 10 k Ω
Output impedance less than 10 k Ω

0 dB = 0.775 V

MODEL IDENTIFICATIONS

Specification Label

TC-K6: US, Canadian model

SONY®		
TAPECORDER TC-K6		
AC 120V	60Hz	17W
NO.		
MADE IN JAPAN		

TC-K6: AEP, E model

SONY®		
TAPECORDER TC-K6		
110 120 220 240V ~ 50/60Hz	19W	
NO.		
MADE IN JAPAN		

TC-K6B: AEP model

SONY®		
TAPECORDER TC-K6B		
110 120 220 240V ~ 50/60Hz	19W	
NO.		
MADE IN JAPAN		

SECTION 1
BLOCK DIAGRAMS

1-1. SYSTEM CONTROL SECTION

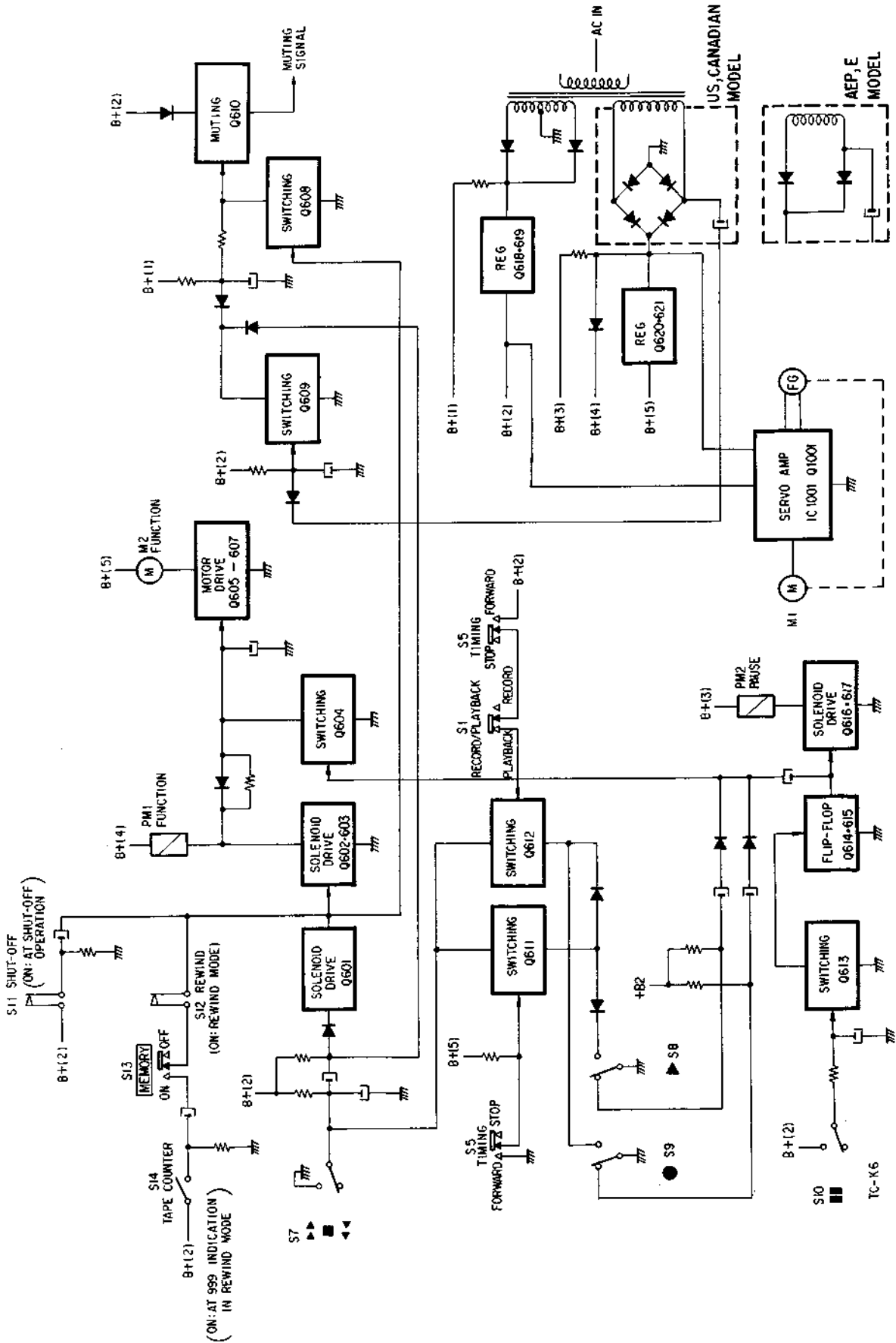

1-2. AMP SECTION

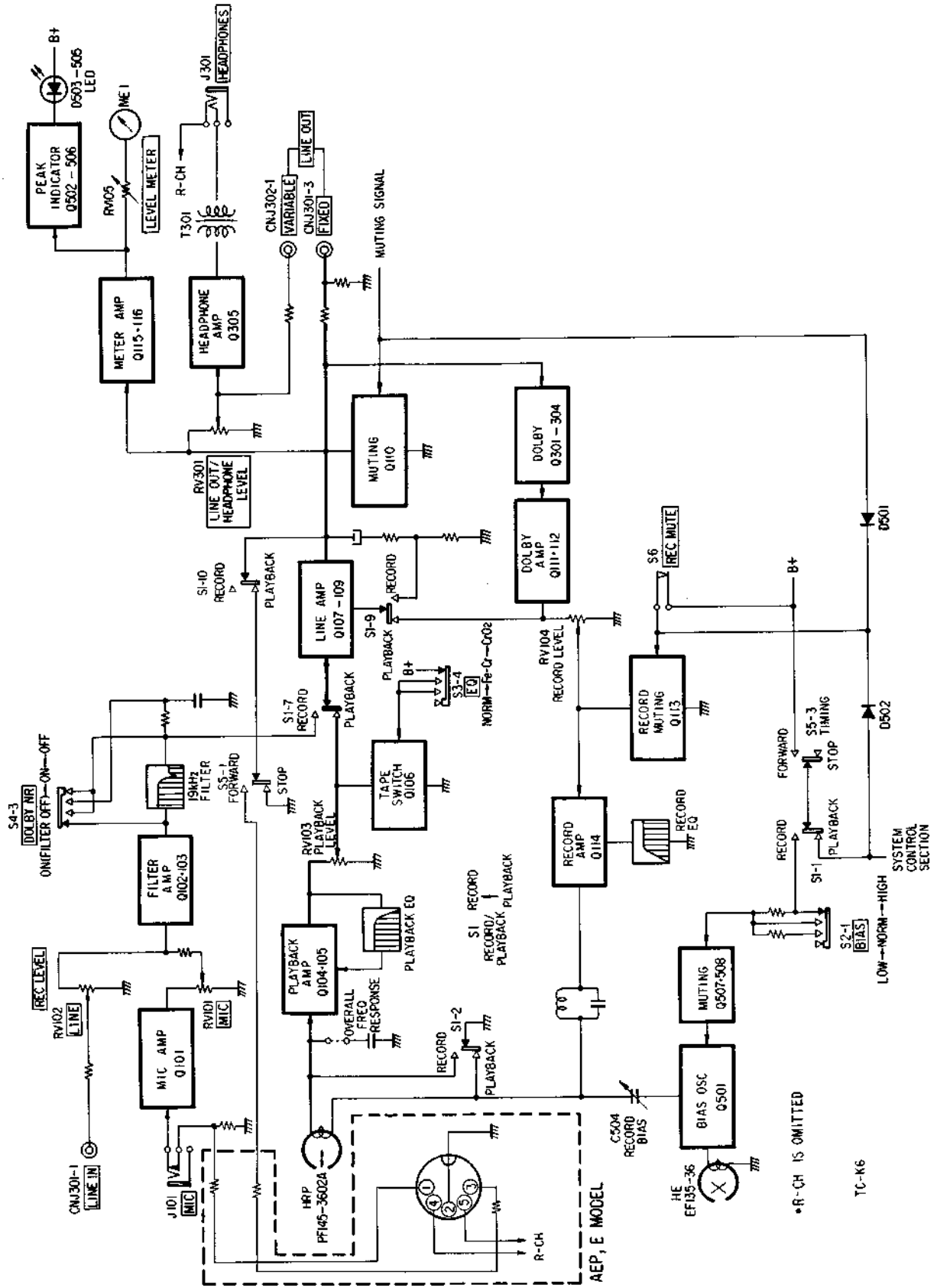

**SECTION 2
DISASSEMBLY**

Note: Remove the parts in the numerical order.

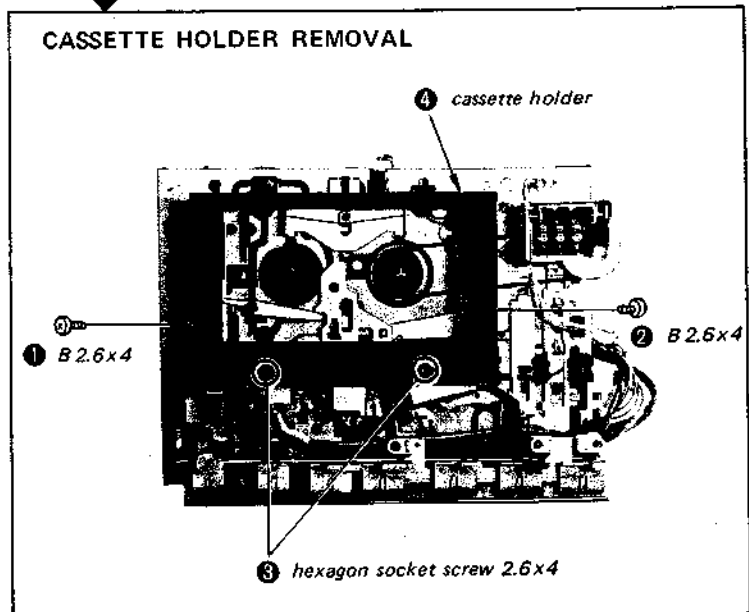
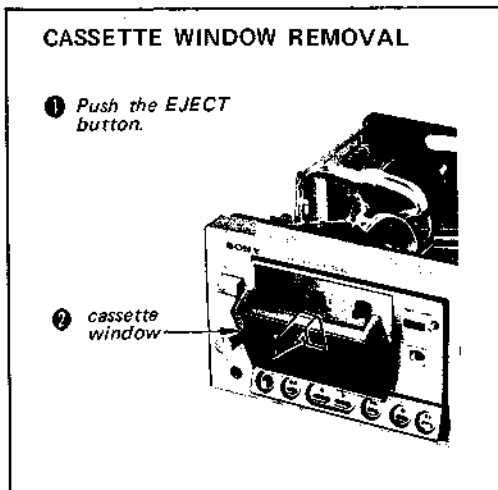
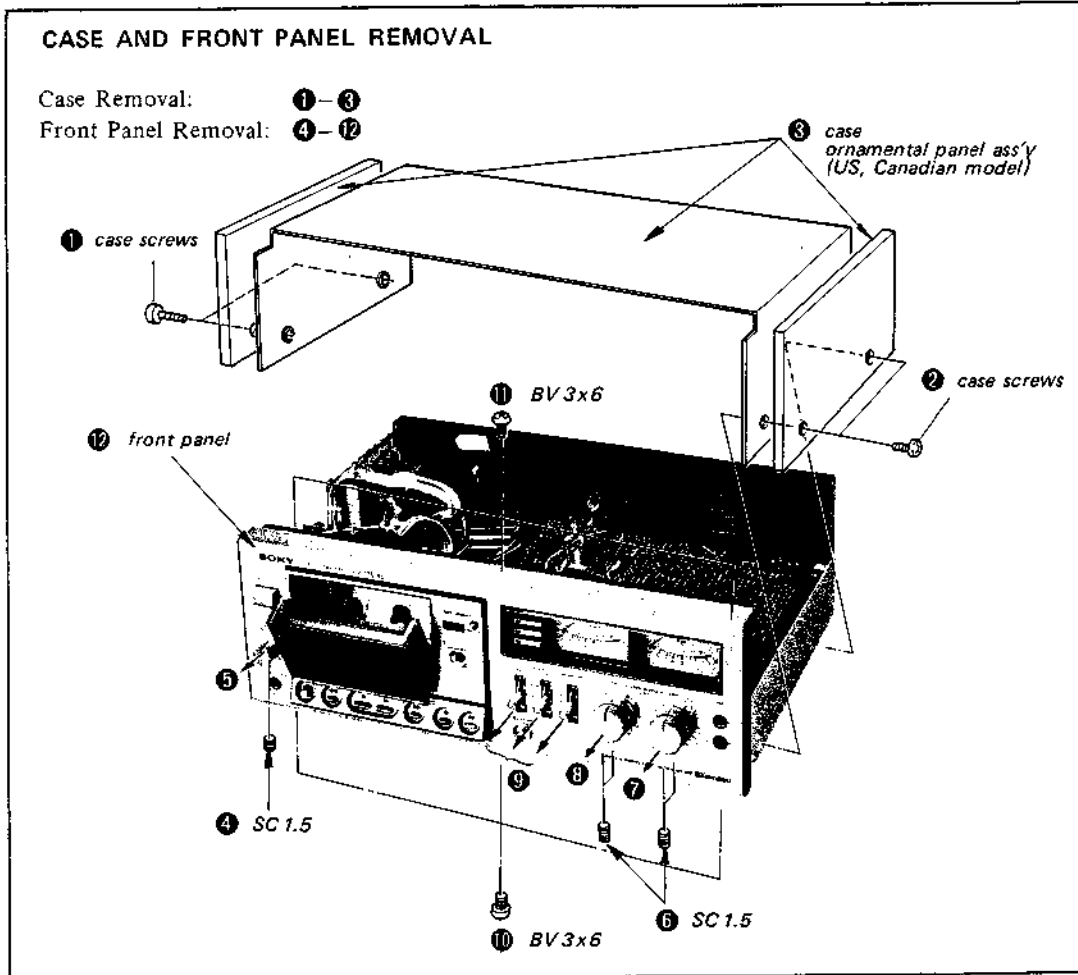

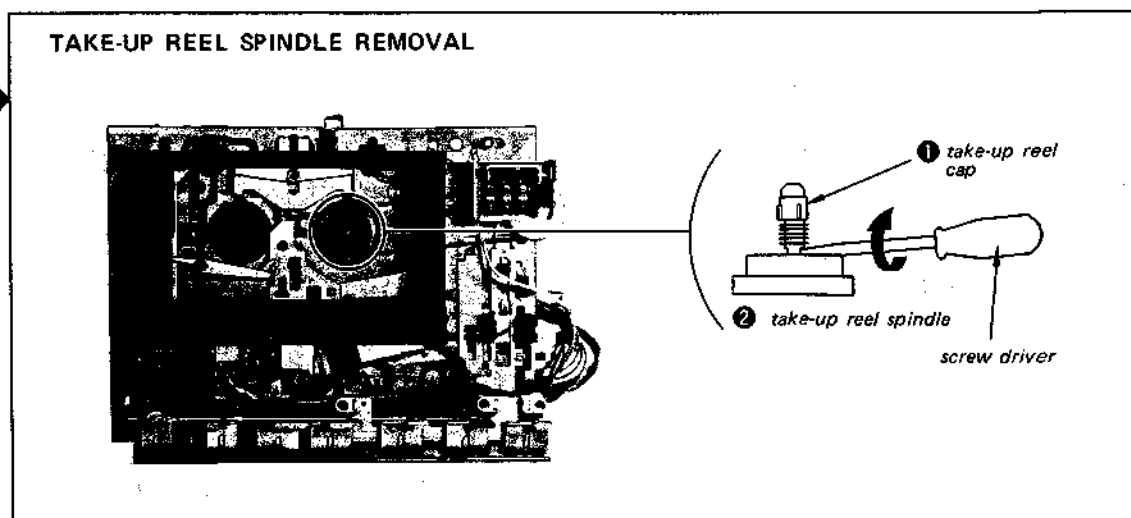
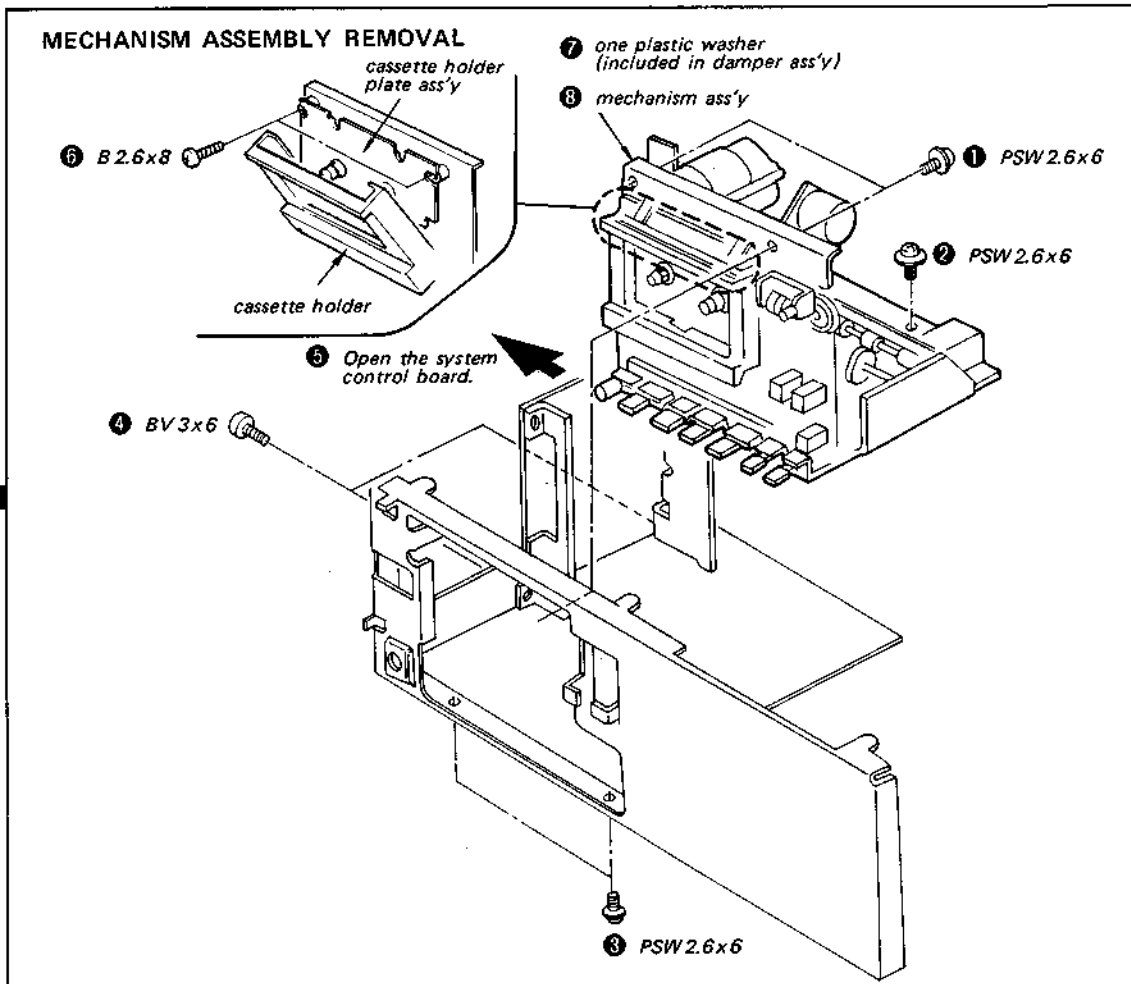

SEPARATION OF MECHANISM SECTION AND FUNCTION BLOCK

7 disconnect two lead wires

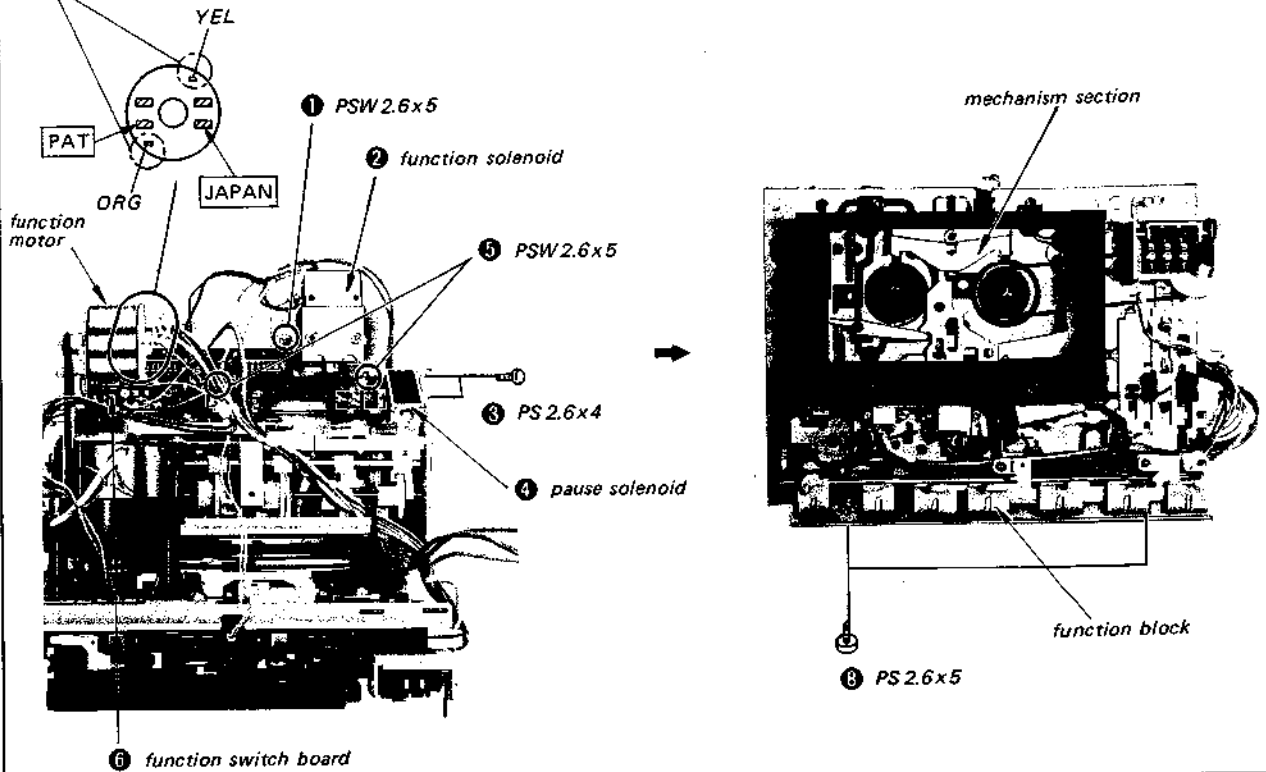

MECHANISM SECTION REMOVAL

Perform steps 1 to 7, then separate the reel spindle plate ass'y and the chassis.

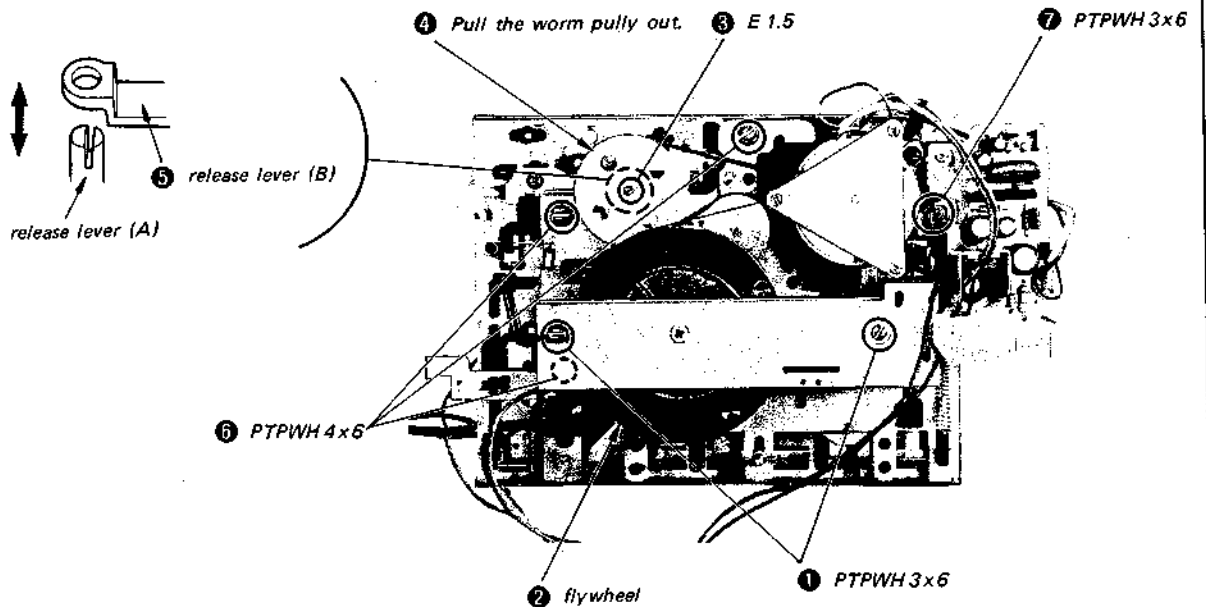

FUNCTION BLOCK REMOVAL

Refer to the exploded views on page 9.

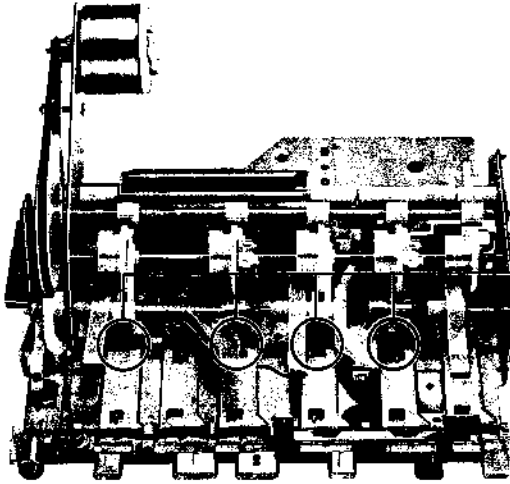

NOTE ON THE FUNCTION BLOCK INSTALLATION

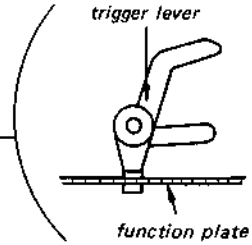

1. The tip of each trigger lever should be in the hole of each function plate.
2. Each gear and lever should be properly installed.

INSTALLATION OF MECHANISM SECTION AND FUNCTION BLOCK

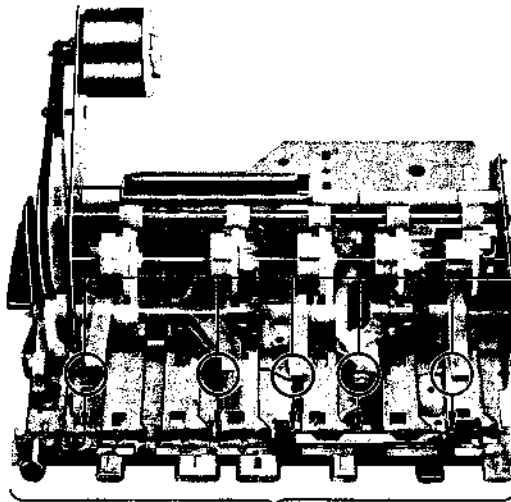

- 1 Push the five shift levers with fingers.

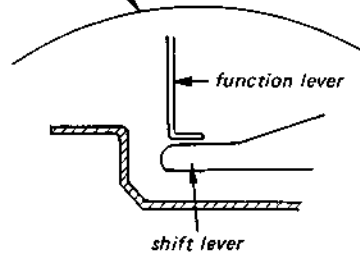

- 2 Set the shift lever under the function lever.
- 3 Install the mechanism section and the function block.

SECTION 3
ADJUSTMENTS

3-1. MECHANICAL ADJUSTMENTS

PRECAUTION

- Clean the following parts with a denatured-alcohol-moistened swab:

record/playback head	pinch roller
erase head	rubber belts
capstan	idlers
- Demagnetize the record/playback head with a head demagnetizer.
- Do not use a magnetized screwdriver for the adjustments.
- After the adjustments, apply a suitable locking compound to the parts adjusted.
- The adjustments should be performed with the rated power supply voltage unless otherwise noted.

Playback Tension Torque Adjustment
— Playback Mode —
Use the type CQ-102A cassette torque meter.

Specification: 2–4.5 g·cm (0.03–0.06 oz·inch)

Tape Path Adjustment
— Playback Mode —

- Make an adjustment cassette as shown below.

C-120 tape cassette
Cut out hatched portions.

- In playback mode and viewing from the front, adjust the head heights to eliminate tape curl and tape twist at arrowed portions.

erase head record/playback head

screwdriver

3-513-237-01 (t=0.1)
3-513-237-11 (t=0.2)
Shim, head height adjustment

Forward Torque Adjustment
— Playback Mode —

- Place the type CQ-102A cassette torque meter in the set.
- Change the position of the adjustment spring catch.

Specification: 28–55 g·cm (0.39–0.77 oz·inch)

take-up reel spindle
adjustment spring catch

adjustment spring catch -Approx. 8 g·cm (0.12 oz·inch) +Approx. 8 g·cm (0.12 oz·inch)

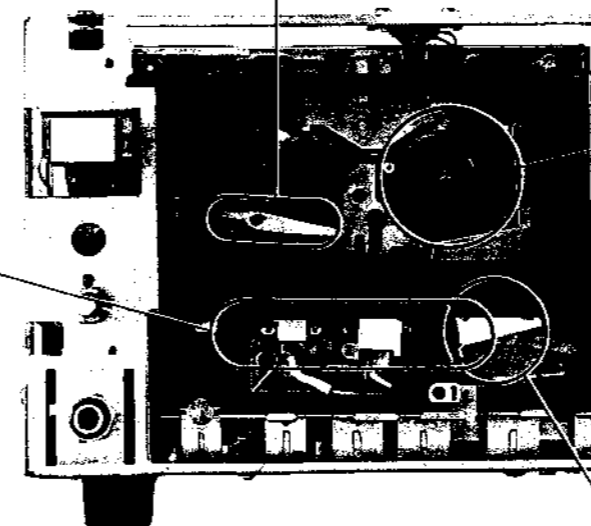

Reference Data
Pinch Roller Pressure: 310–390 g (11–14 oz)

Function Switch Board Position Adjustment

1. Push the forward button (▶) with the gear held, and confirm that the condition of the gear and the tip of trigger lever is as shown below.
2. Adjust the position of the function switch board so that the motor rotates.

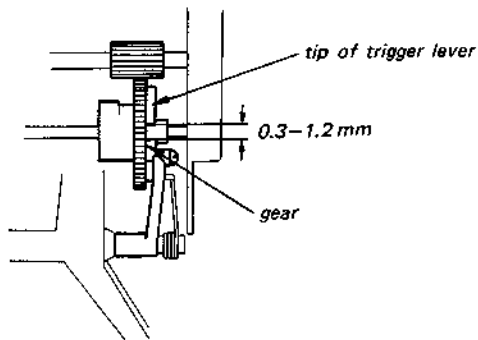

Function Solenoid (PM1) Position Adjustment

2. Adjust the position of the function solenoid for the specified clearance.

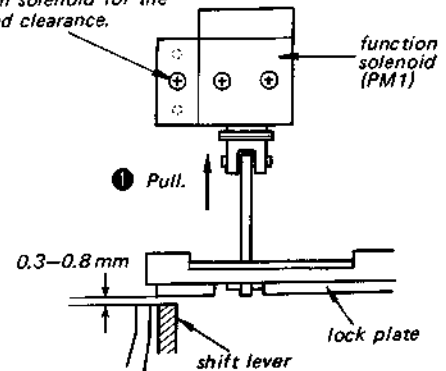

Function Motor Pulley Height Adjustment

Adjust the position of the motor pulley for the specified clearance.

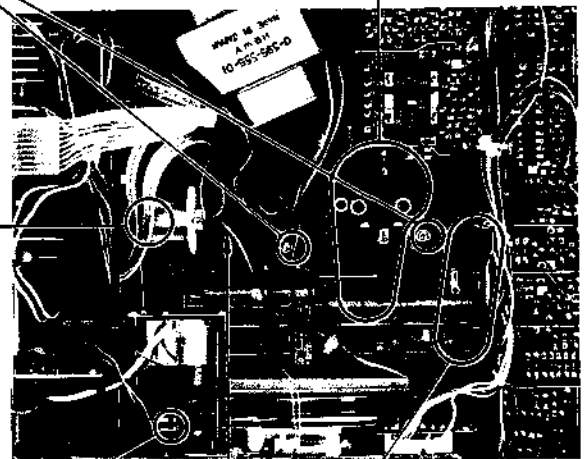
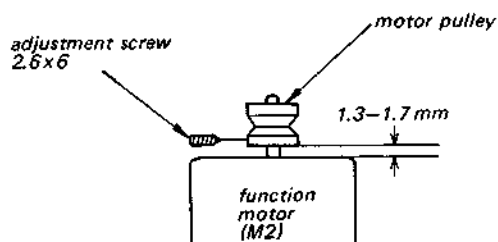

function switch board

Capstan Motor Pulley Height Adjustment

Adjust the position of the motor pulley for the specified clearance.

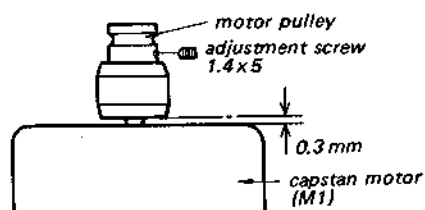

Pause Solenoid (PM2) Position Adjustment

1. Push the pole piece.
2. Adjust the position of the pause solenoid for the specified clearance.

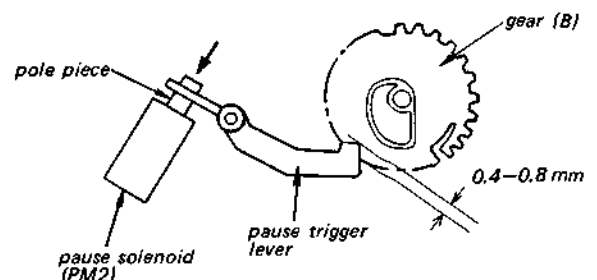

Shut-off Switch (S11) Position Adjustment

Adjust the position of the shut-off switch (S11).

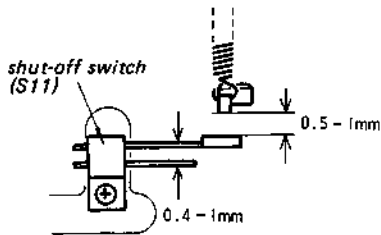

Motor Switch (S16) and Rewind Switch (S12) Position Adjustment

Adjust the positions of switches.

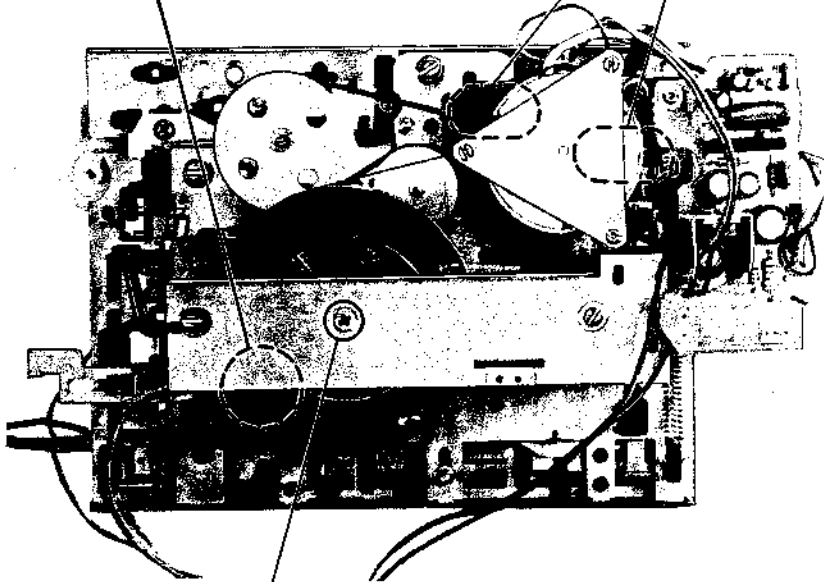
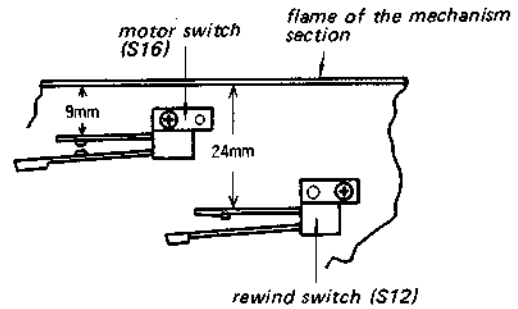

Thrust Play Adjustment

— Playback Mode —

1. Loosen the thrust screw.
2. Carefully turn the thrust screw clockwise until current suddenly increases. Then loosen the thrust screw $\frac{1}{4}$ turn.
3. Secure the thrust screw with a suitable locking compound.

3-2. ELECTRICAL ADJUSTMENTS

Note: The adjustment should be performed in the order given in this service manual. The adjustments should be performed for both L-CH and R-CH.

BIAS and EQ switch settings in accordance with tape used are as follows.

Tape	BIAS switch	EQ switch
CS-10	NORMAL	NORMAL
CS-20	HIGH	CrO ₂
CS-30	NORMAL	Fe-Cr

Switches and controls should be set as follows unless otherwise specified.

- DOLBY NR switch: OFF
- LINE OUT/HEADPHONE LEVEL control: MAX
- EQ switch: NORMAL
- BIAS switch: NORMAL
- MEMORY switch: OFF
- REC MUTE switch: OFF

Standard Record:

Deliver the standard input signal level to the input jack and set the MIC REC VOL and LINE REC VOL controls to obtain the standard output signal level.

Standard Input Level

	MIC	LINE IN	REC/PB (AEP and E model)
source impedance	300 Ω	10 kΩ	100 kΩ
input level	0.77 mV (-60 dB)	0.25 V (-10 dB)	17 mV (-33 dB)

Standard Output Level

	VARIABLE LINE OUT	FIXED LINE OUT	HEAD- PHONES	REC/PB (AEP and E model)
load impedance	100 kΩ	100 kΩ	8 Ω	50 kΩ
output level	0.775 V (0 dB)	0.44 V (-5 dB)	95 mV (-18 dB)	0.775 V (0 dB)

Tape Speed Adjustment

Procedure:

Mode: Playback

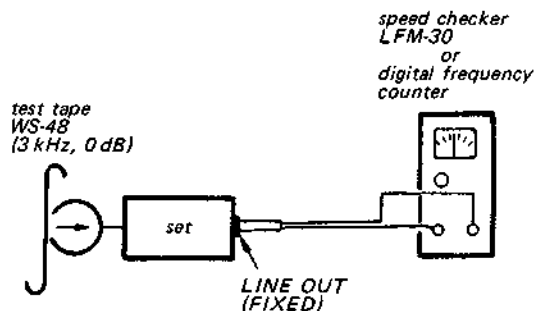

Specification:

Speed checker	Digital frequency counter
-0.7~+0.7%	2,980~3,020 Hz

Frequency difference between beginning and end of tape should be within 0.7% (20 Hz).

Adjustment Location:

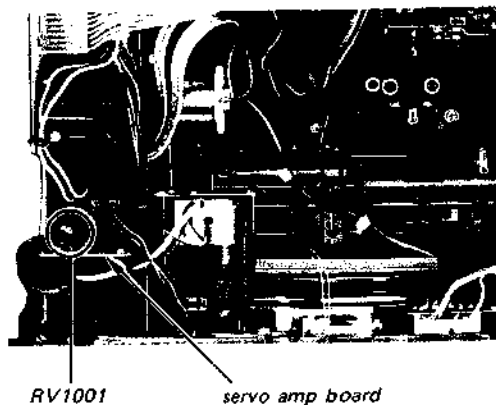

Record/playback Head Azimuth Adjustment

Procedure:

1. Mode: Playback

test tape
P-4-A81
(6.3 kHz, -10 dB)

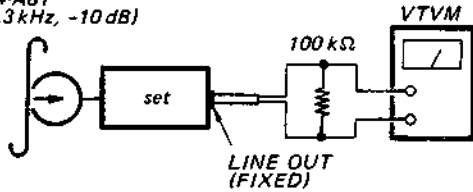

2. Turn the adjustment screw for the maximum level and set it to the mechanical mid position between L-CH and R-CH peak positions.

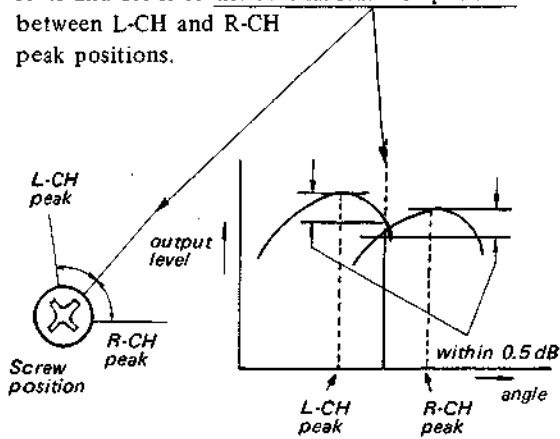

3. Mode: Playback

test tape
P-4-A81
(6.3 kHz, -10 dB)

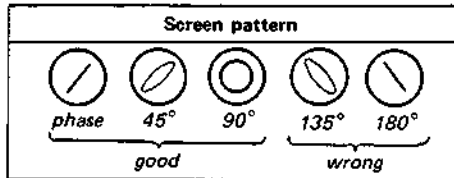
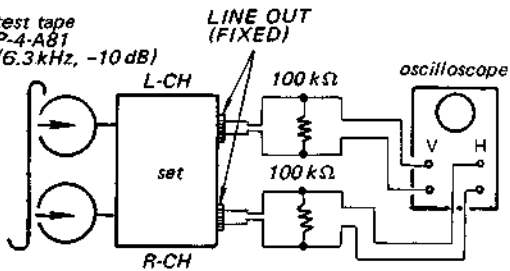

Adjustment Location:

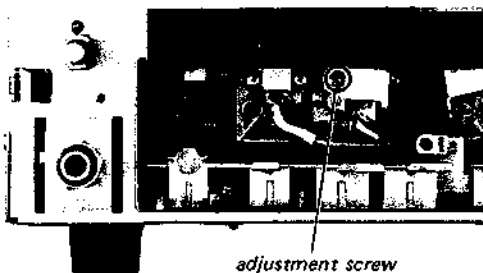

Playback Level Adjustment

Procedure:

test tape
P-4-L81
(333 Hz, 0 dB)

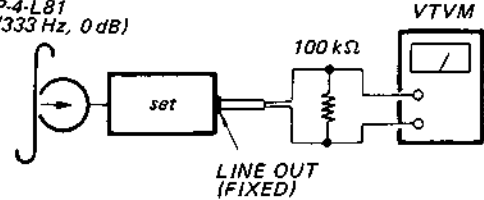

Specification:

LINE OUT level: 0.52–0.58 V (–3.5 – –2.5 dB)

Check that LINE OUT level does not change in playback mode while changing the mode from playback to stop several times.

Adjustment Location:

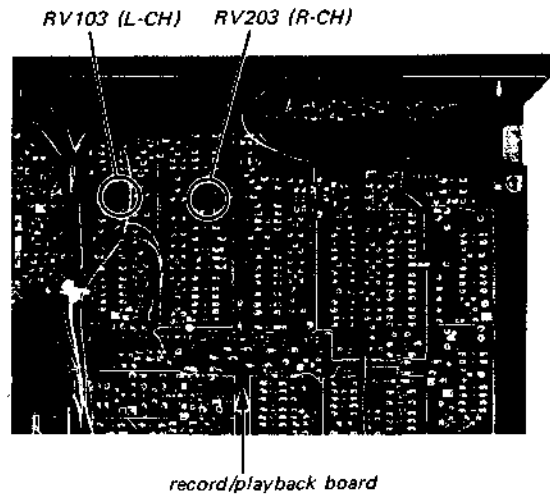

Playback Equalizer Adjustment

Procedure:

Mode: Playback

test tape
P-4-A82
(10 kHz, -10 dB)

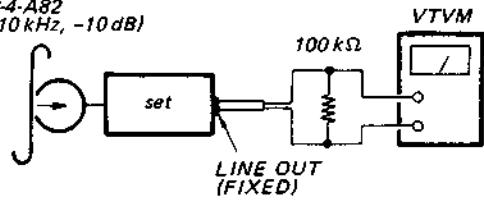

Specification:

EQ switch	LINE OUT (FIXED) level
NORMAL	0.26 – 0.37V (-9.5 – -6.5 dB)
Fe-Cr or Cr-O ₂	0.16 – 0.22V (-14 – -11 dB)

Adjustment Location:

Bridge patterns	High frequency level
(open)	↑ up
(A)	↓ down

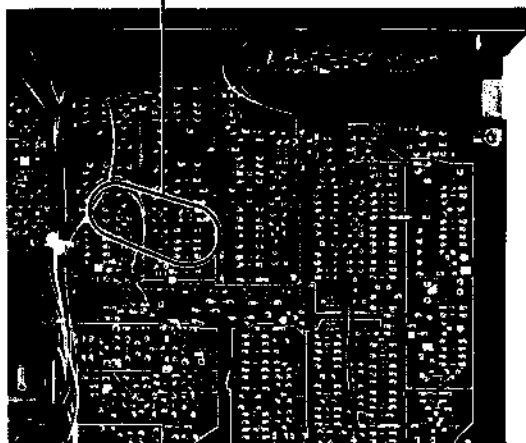
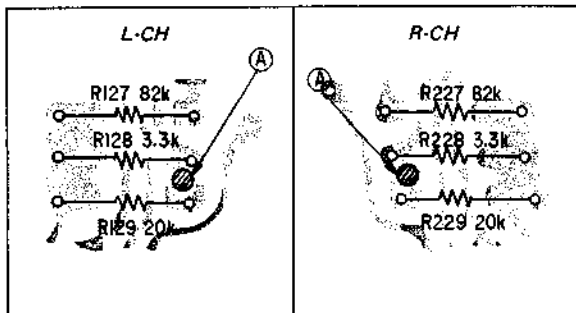

record/playback board

VU Meter Adjustment

Procedure:

1. Mode: Standard record (See page 15.)

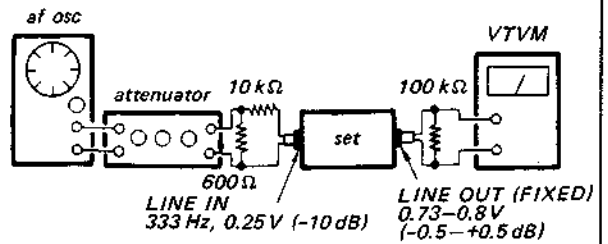

2.

Adjust	VU meter reading: 0VU
RV105 (L-CH)	
RV205 (R-CH)	

Adjustment Location:

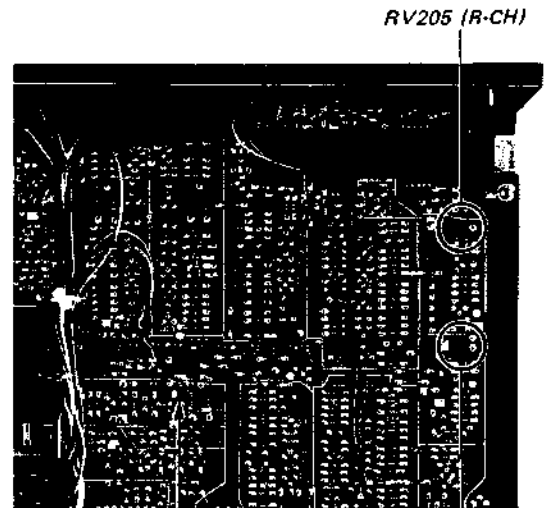

record/playback board

RV105 (L-CH)

Record Bias Adjustment

Procedure:

1. Mode: Standard record (See page 15.)

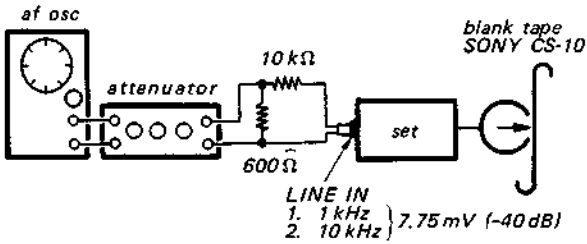

2. Mode: Playback

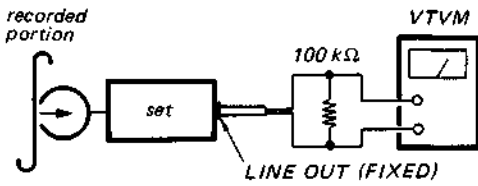

Adjust C504 (L-CH) and C505 (R-CH) to make 10 kHz and 1 kHz signal output levels equal.

Adjustment Location:

Note: Normally, patterns at **A** are bridged. If adjustment is not made with trimmers fully tightened, unsolder the bridged patterns at **A** and at **B**, then repeat the adjustment.

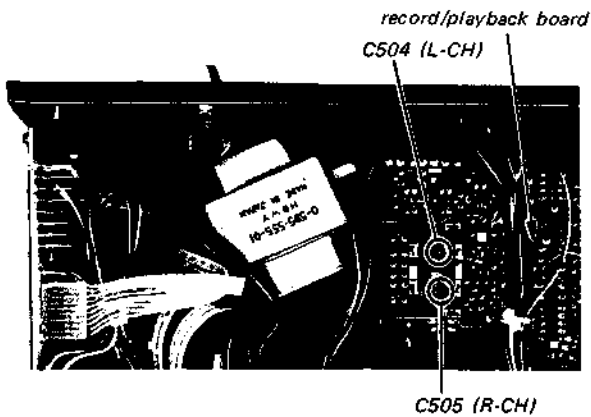
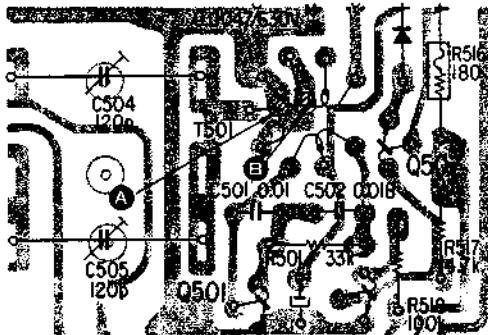

Record Level Adjustment

Procedure:

1. Mode: Standard record (See page 15.)

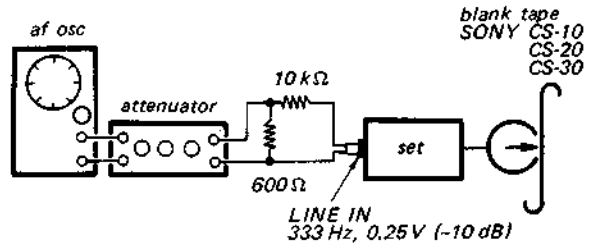

2. Mode: Playback

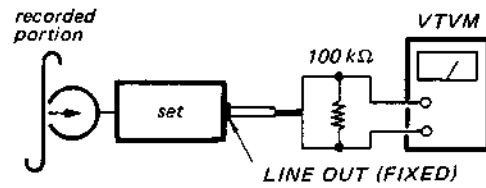

Specification:

SONY tape	LINE OUT level
CS-10	0.73 - 0.8 V (-0.5 - +0.5 dB)
CS-20	0.55 - 0.73 V (-0.5 - -3 dB)
CS-30	0.65 - 0.9 V (-1.5 - +1.5 dB)

Adjustment Location:

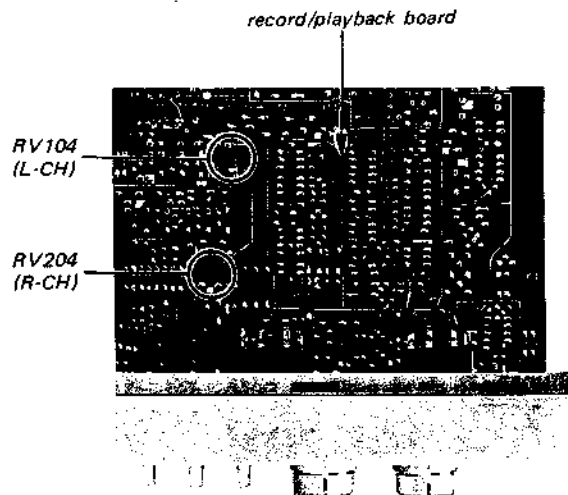

Overall Frequency Response Adjustment

Procedure:

1. Mode: Standard record (See page 15.)

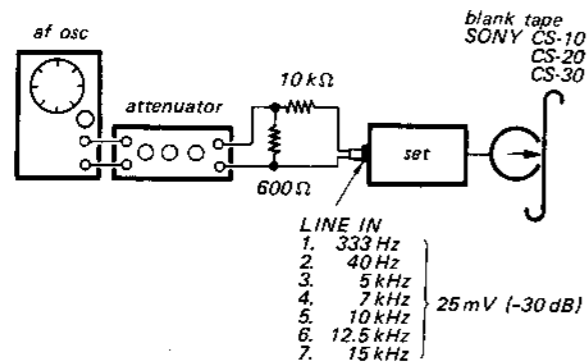

2. Mode: Playback

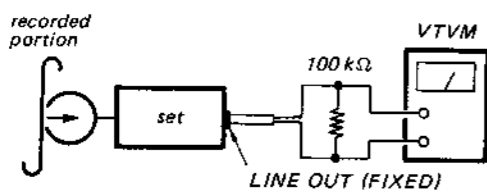

3. Measure LINE OUT level with 333Hz output level as reference.

Tape freq.	CS-10	CS-20	CS-30
40 Hz	+2 dB -1 dB	+2 dB -1 dB	+2 dB -1 dB
5 kHz	±2 dB	+3 dB -2 dB	±2 dB
7 kHz		+4 dB -1 dB	
10 kHz		+4 dB -2 dB	
12.5 kHz	±3 dB	+4 dB -2 dB	±3 dB
15 kHz			

If the 15 kHz level is out of the specification, adjust by bridging patterns. The 10 kHz level will go up (about +1.3 dB), and the 15 kHz level will go up (about +2 dB).

Adjustment Location:

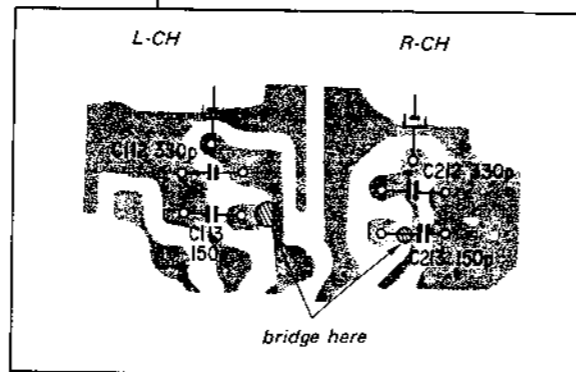
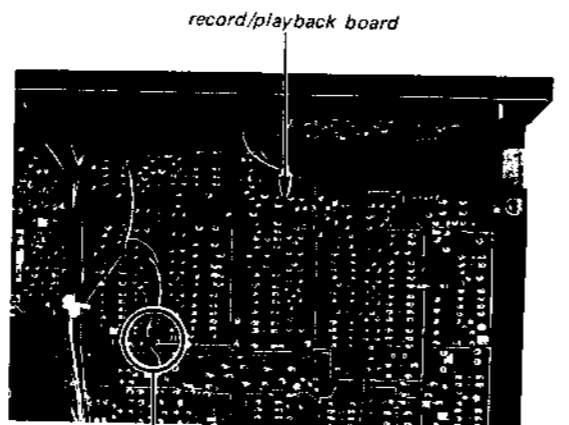

19 kHz Filter Adjustment

Procedure:

1. Mode: Standard record (See page 15.)
2. DOLBY NR switch: ON (FILTER ON)
Adjust L102 (L-CH) and L202 (R-CH) for minimum VTVM reading.

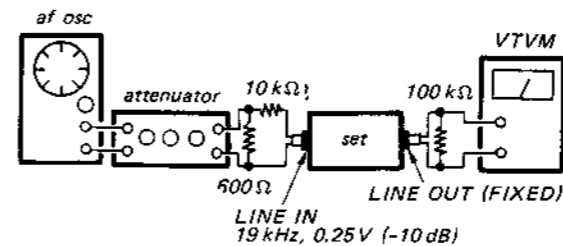

Adjustment Location:

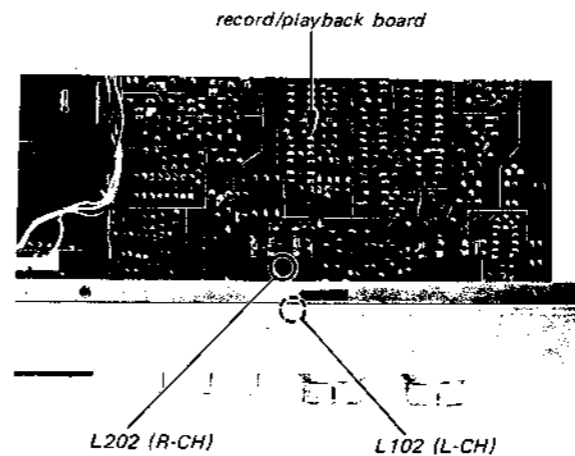

19 kHz Filter Adjustment

Procedure:

1. Mode: Standard record (See page 15.)
2. DOLBY NR switch: ON (FILTER ON)
Adjust L102 (L-CH) and L202 (R-CH) for minimum VTVM reading.

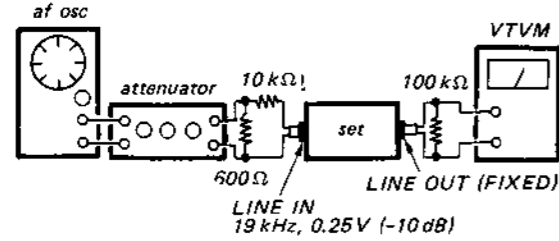

Adjustment Location:

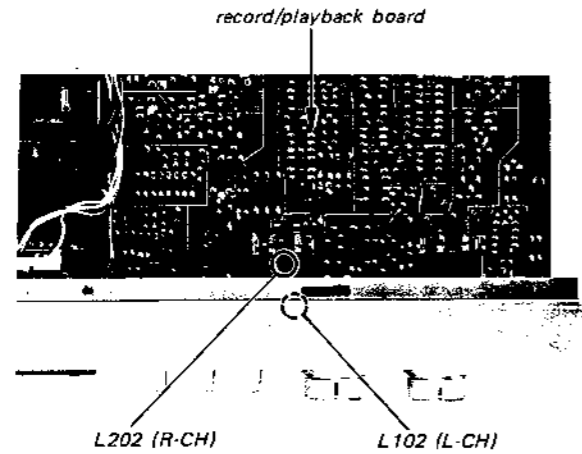

1/4 WATT CARBON RESISTORS

Ω	Part No.	Ω	Part No.	Ω	Part No.	Ω	Part No.	Ω	Part No.	Ω	Part No.		
1.0	1-244-601-11	10	1-244-625-11	100	1-244-649-11	1.0k	1-244-673-11	10k	1-244-697-11	100k	1-244-721-11	1.0M	1-244-745-11
1.1	1-244-602-11	11	1-244-626-11	110	1-244-650-11	1.1k	1-244-674-11	11k	1-244-698-11	110k	1-244-722-11	1.1M	1-244-746-11
1.2	1-244-603-11	12	1-244-627-11	120	1-244-651-11	1.2k	1-244-675-11	12k	1-244-699-11	120k	1-244-723-11	1.2M	1-244-747-11
1.3	1-244-604-11	13	1-244-628-11	130	1-244-652-11	1.3k	1-244-676-11	13k	1-244-700-11	130k	1-244-724-11	1.3M	1-244-748-11
1.5	1-244-605-11	15	1-244-629-11	150	1-244-653-11	1.5k	1-244-677-11	15k	1-244-701-11	150k	1-244-725-11	1.5M	1-244-749-11
1.6	1-244-606-11	16	1-244-630-11	160	1-244-654-11	1.6k	1-244-678-11	16k	1-244-702-11	160k	1-244-726-11	1.6M	1-244-750-11
1.8	1-244-607-11	18	1-244-631-11	180	1-244-655-11	1.8k	1-244-679-11	18k	1-244-703-11	180k	1-244-727-11	1.8M	1-244-751-11
2.0	1-244-608-11	20	1-244-632-11	200	1-244-656-11	2.0k	1-244-680-11	20k	1-244-704-11	200k	1-244-728-11	2.0M	1-244-752-11
2.2	1-244-609-11	22	1-244-633-11	220	1-244-657-11	2.2k	1-244-681-11	22k	1-244-705-11	220k	1-244-729-11	2.2M	1-244-753-11
2.4	1-244-610-11	24	1-244-634-11	240	1-244-658-11	2.4k	1-244-682-11	24k	1-244-706-11	240k	1-244-730-11	2.4M	1-244-754-11
2.7	1-244-611-11	27	1-244-635-11	270	1-244-659-11	2.7k	1-244-683-11	27k	1-244-707-11	270k	1-244-731-11	2.7M	1-244-755-11
3.0	1-244-612-11	30	1-244-636-11	300	1-244-660-11	3.0k	1-244-684-11	30k	1-244-708-11	300k	1-244-732-11	3.0M	1-244-756-11
3.3	1-244-613-11	33	1-244-637-11	330	1-244-661-11	3.3k	1-244-685-11	33k	1-244-709-11	330k	1-244-733-11	3.3M	1-244-757-11
3.6	1-244-614-11	36	1-244-638-11	360	1-244-662-11	3.6k	1-244-686-11	36k	1-244-710-11	360k	1-244-734-11	3.6M	1-244-758-11
3.9	1-244-615-11	39	1-244-639-11	390	1-244-663-11	3.9k	1-244-687-11	39k	1-244-711-11	390k	1-244-735-11	3.9M	1-244-759-11
4.3	1-244-616-11	43	1-244-640-11	430	1-244-664-11	4.3k	1-244-688-11	43k	1-244-712-11	430k	1-244-736-11	4.3M	1-244-760-11
4.7	1-244-617-11	47	1-244-641-11	470	1-244-665-11	4.7k	1-244-689-11	47k	1-244-713-11	470k	1-244-737-11	4.7M	1-244-761-11
5.1	1-244-618-11	51	1-244-642-11	510	1-244-666-11	5.1k	1-244-690-11	51k	1-244-714-11	510k	1-244-738-11	5.1M	1-244-762-11
5.6	1-244-619-11	56	1-244-643-11	560	1-244-667-11	5.6k	1-244-691-11	56k	1-244-715-11	560k	1-244-739-11		
6.2	1-244-620-11	62	1-244-644-11	620	1-244-668-11	6.2k	1-244-692-11	62k	1-244-716-11	620k	1-244-740-11		
6.8	1-244-621-11	68	1-244-645-11	680	1-244-669-11	6.8k	1-244-693-11	68k	1-244-717-11	680k	1-244-741-11		
7.5	1-244-622-11	75	1-244-646-11	750	1-244-670-11	7.5k	1-244-694-11	75k	1-244-718-11	750k	1-244-742-11		
8.2	1-244-623-11	82	1-244-647-11	820	1-244-671-11	8.2k	1-244-695-11	82k	1-244-719-11	820k	1-244-743-11		
9.1	1-244-624-11	91	1-244-648-11	910	1-244-672-11	9.1k	1-244-696-11	91k	1-244-720-11	910k	1-244-744-11		

HARDWARE NOMENCLATURE

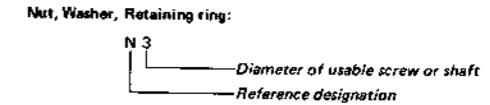
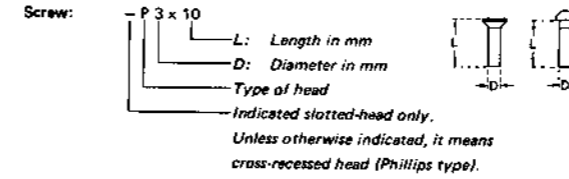

Reference Designation	Shape	Description	Remarks
SCREWS			
P		pan-head screw	binding-head (B) screw for replacement
PWH		pan-head screw with washer face	binding-head (B) screw and flat washer for replacement
PS PSP		pan-head screw with spring washer	binding-head (B) screw and spring washer for replacement
PSW PSPW		pan-head screw with spring and flat washers	binding-head (B) screw and spring and flat washers for replacement
R		round-head screw	binding-head (B) screw for replacement
K		flat-countersunk-head screw	
RK		oval-countersunk-head screw	
B		binding-head screw	
T		truss-head screw	binding-head (B) screw for replacement
F		flat-fillister-head screw	
RF		fillister-head screw	
BV		brazer-head screw	

Reference Designation	Shape	Description	Remarks
SELF-TAPPING SCREWS			
TA		self-tapping screw	ex: TA, P 3 x 10
PTP		pan-head self-tapping screw	binding-head self-tapping (TA, B) screw for replacement
PTPWH		pan-head self-tapping screw with washer face	binding-head self-tapping (TA, B) screw and flat washer for replacement
PTTWH		pan-head thread-rolling screw with washer face	binding-head (B) screw and flat washer for replacement
SET SCREWS			
SC		set screw	
SC		hexagon-socket set screw	ex: SC 2.6 x 4, hexagon socket
NUT			
N		nut	
WASHERS			
W		flat washer	
SW		spring washer	
LW		internal-tooth lock washer	ex: LW3, internal
LW		external-tooth lock washer	ex: LW3, external
RETAINING RINGS			
E		retaining ring	
G		grip-type retaining ring	

SECTION 4
DIAGRAMS

4-1. MOUNTING DIAGRAM - System Control Section -

- Conductor Side -

Replacement Semiconductors

For replacement, use semiconductors except in ().

Q601, 602, 604-606
Q608, 609, 611-615 : 2SC634A
Q618, 621

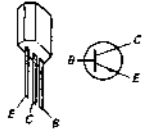

Q1001: 2SC1061 (2SC1419)

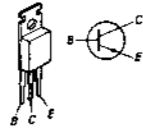

D617: EQB01-12 (EQA01-12R)
D622: EQB01-08 (EQA01-08R)



Q603, 607, 617: 2SC1475

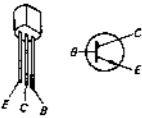

IC1001: CX065A (CX065)



D618, 619
D623-629
(US, Canadian model) : 10E2
D623, 625, 627, 629
(AEP, E model)

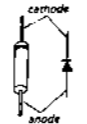

Q610: 2SA678

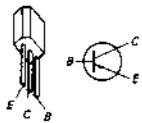

D601-616, 620
D621, 630, 631 : 1S1555 (1T40)

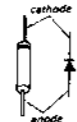

(S1B01-02)

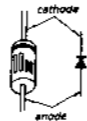

Q619, 620: 2SC1173

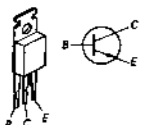

- Note:
- [] : B+ pattern.
 - [] : FORWARD
 - [] : STOP
 - [] : PAUSE
 - Color code of sleeving over the end of the jacket.

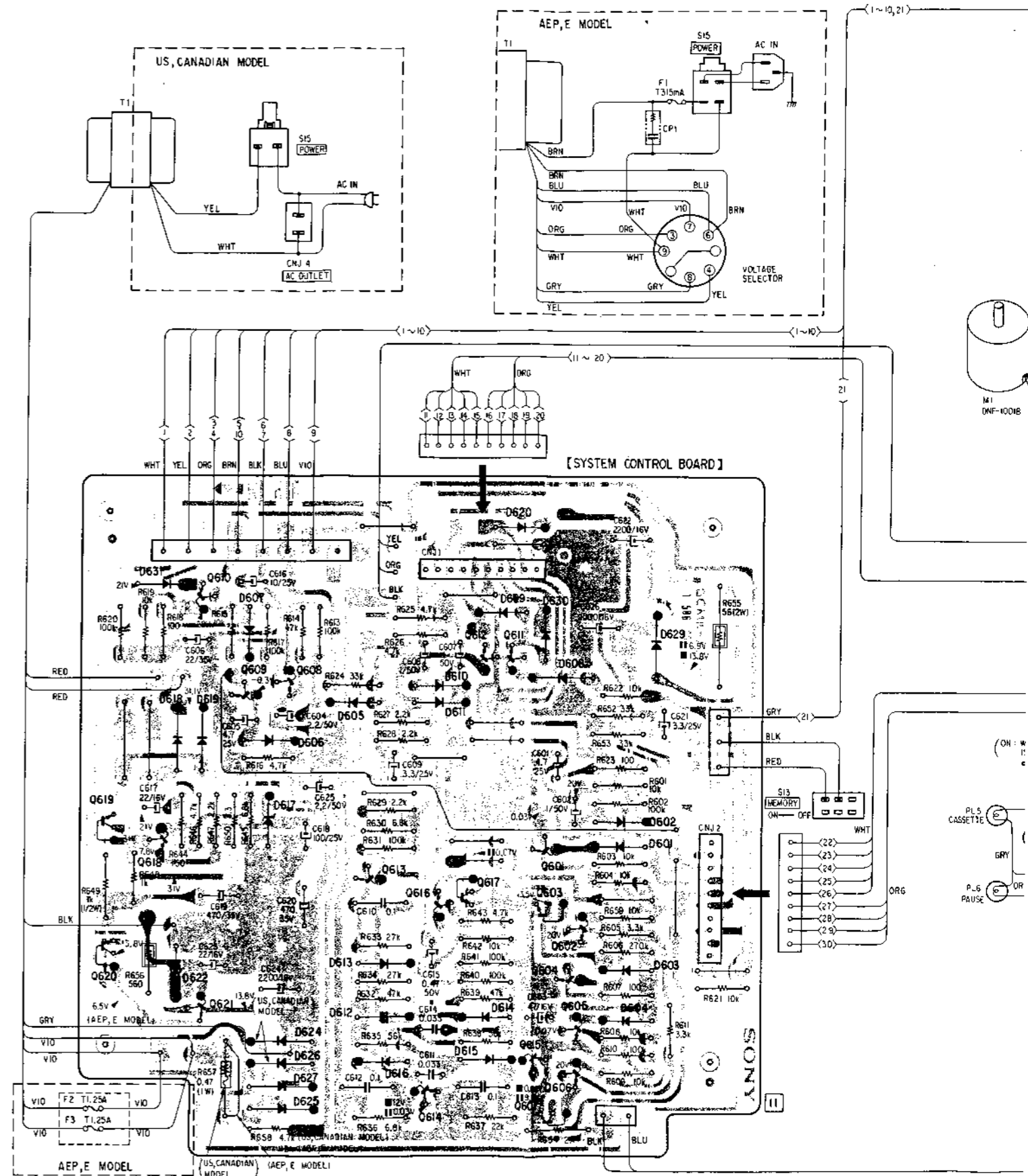
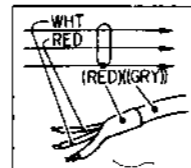

Q	619	618	610	609	608	613	614	617	612	611	601	602					
IC	620	618	621	606	608	613	614	617	612	611	615	603					
D		631	618	619	607	606	624	626	605	613	610	614	609	620	608	602	629
			622		617	625	627	628	616	611	615	630	608	601	603	604	

4-2. SCHEMATIC DIAGRAM — System Control Section —

— System Control Section —

Note: The components identified by shading and Δ mark are critical for safety. Replace only with part number specified.

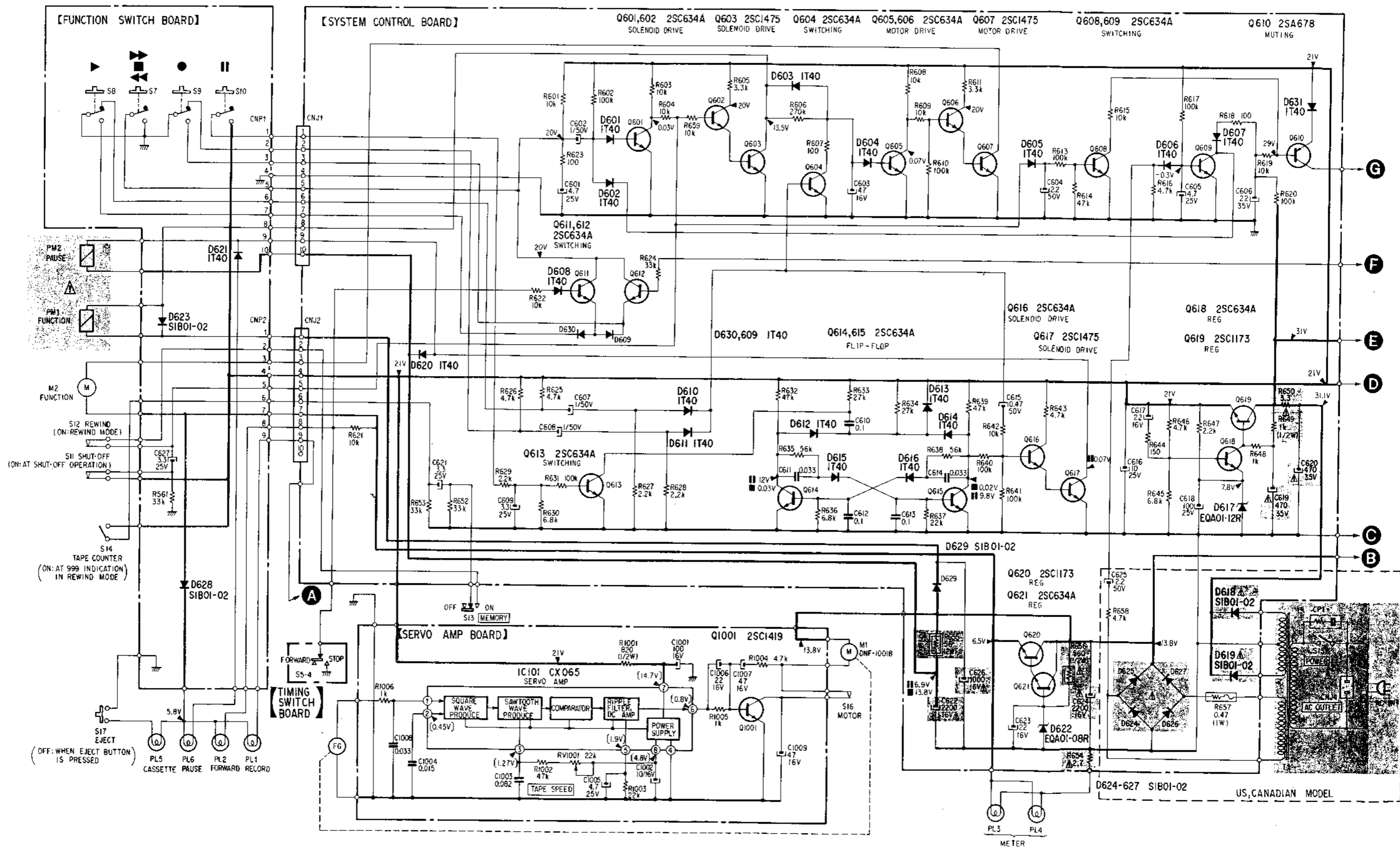

mark
art number

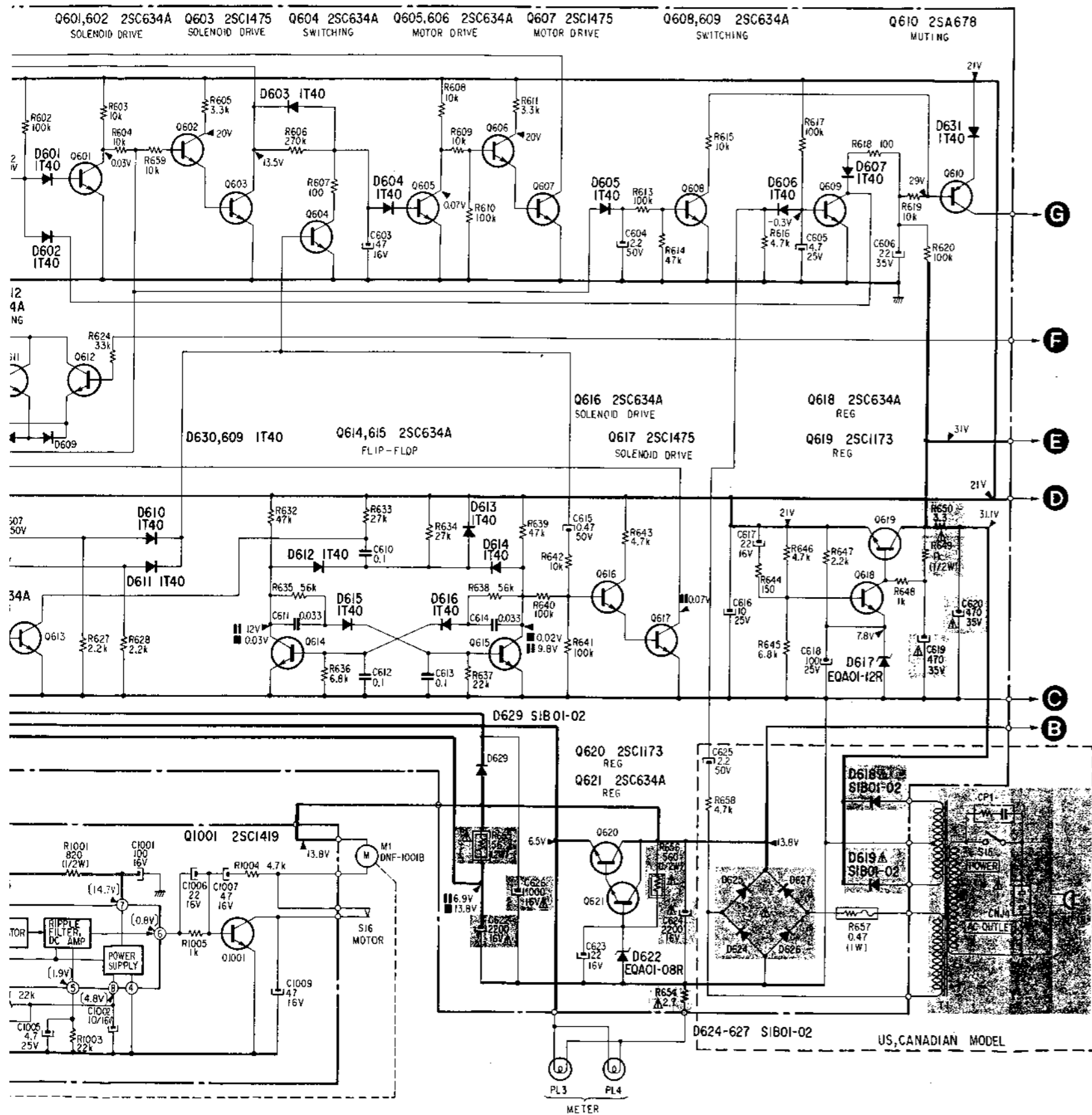

Note:

- All capacitors are in μF unless otherwise noted. $\text{pF} = \mu\mu\text{F}$. 50WV or less are not indicated except for electrolytics.
- All resistors are in ohms, $\frac{1}{2}\text{W}$ unless otherwise noted. $\text{k}\Omega = 1000\Omega$, $\text{M}\Omega = 1000\text{k}\Omega$
- : nonflammable resistor.
- : fusible resistor.
- : B+ bus.
- : panel designation.
- : adjustment for repair.
- Voltages are dc with respect to ground unless otherwise noted.
- Readings are taken under no signal conditions with a VOM (20 $\text{k}\Omega/\text{V}$).
- [] : FORWARD
- ■ : STOP
- || : PAUSE
- Voltage variations may be noted due to normal production tolerances.
- Switch

Ref. No.	Switch	Position
S7	STOP, REWIND, FAST FORWARD	OFF
S8	FORWARD	OFF
S9	REC	OFF
S10	PAUSE	OFF
S11	SHUT-OFF	OFF
S12	REWIND	OFF
S13	MEMORY	OFF
S14	TAPE COUNTER	OFF
S15	POWER	OFF
S16	MOTOR	OFF
S17	EJECT	OFF

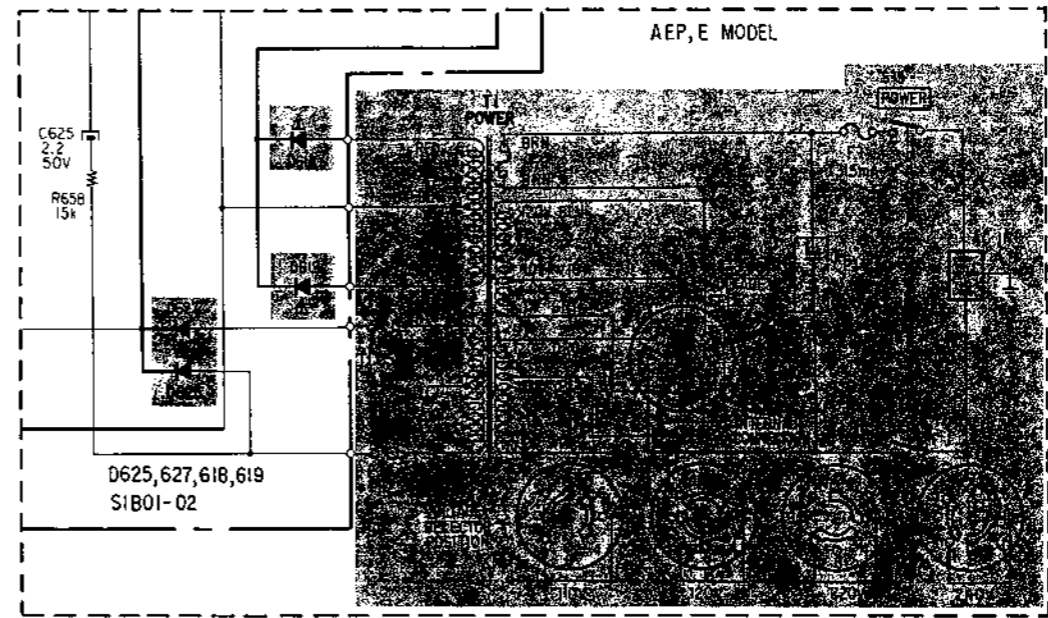

4-3. MOUNTING DIAGRAM

- Amp Section -
- Conductor Side -

Replacement Semiconductors
For replacement, use semiconductors except in ().

Q101-105, 107, 111 } 2SC1345
Q201-205, 207, 211 }

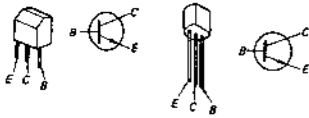

Q106, 108-110, 113 } 2SC634A
Q206, 208-210, 213 }
Q114-116, 224-226 } (2SC633A)
Q301-305, 502-508 }
Q401-405 }

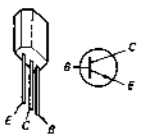

Q112, 212: 2SA678 (2SA677)

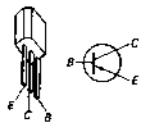

Q501: 2SC1475 (2SC1318)

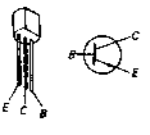

D301, 302 } 1S1555
D401, 402 }
D303, 403 } 1T22A
D304, 404 } 1S1555 (1T40)
D501, 502, 506 }

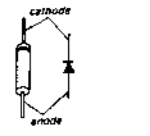

D503-505: SLP24B

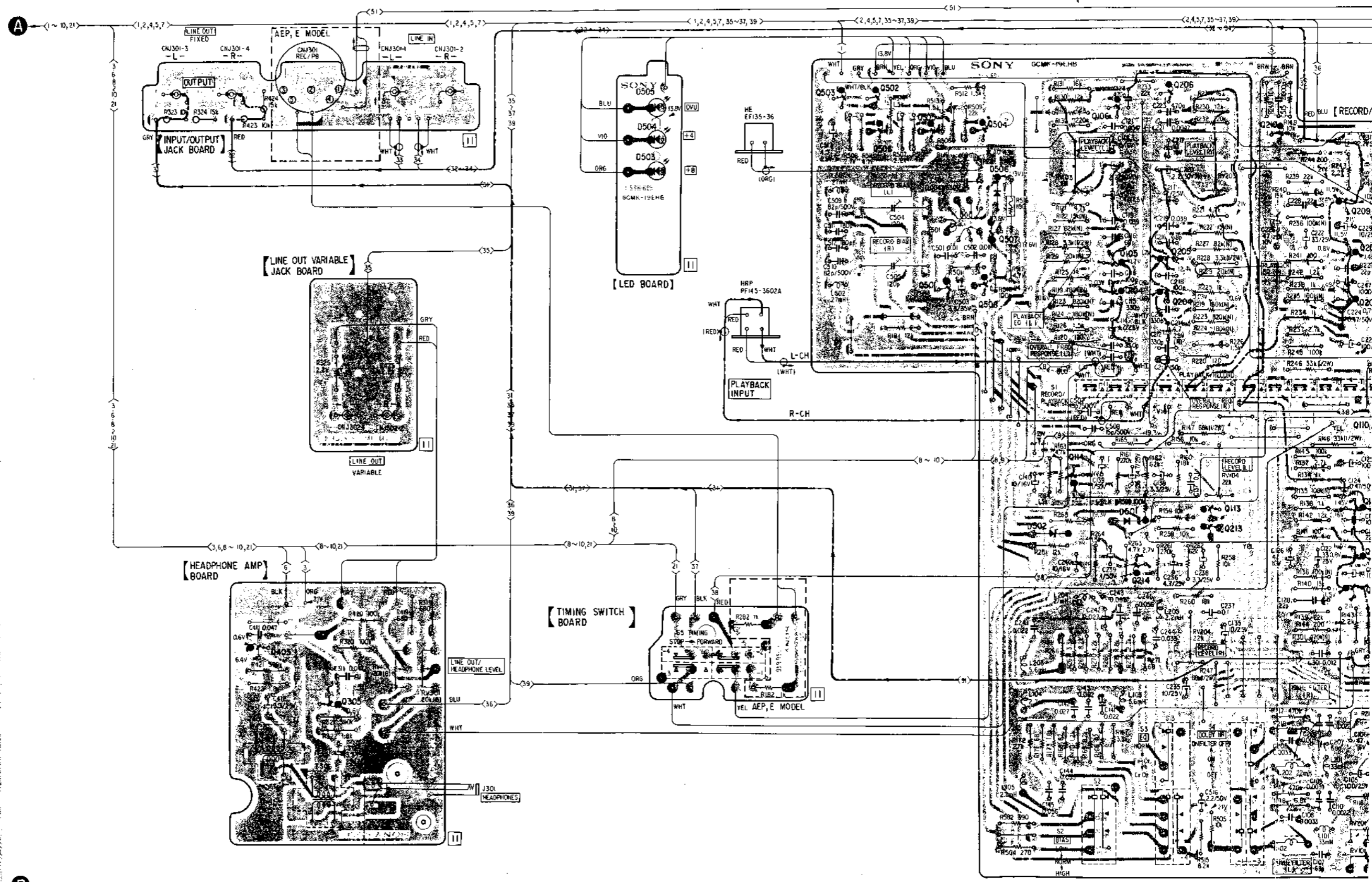
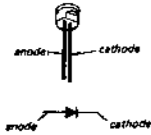

Q	405	305				503	502	505	504	114	106	206	113	210	209	107
D							506	501	508 507		105	205	213		208	108
									506	502	501				207	109

TC-K6/K6B TC-K6/K6B

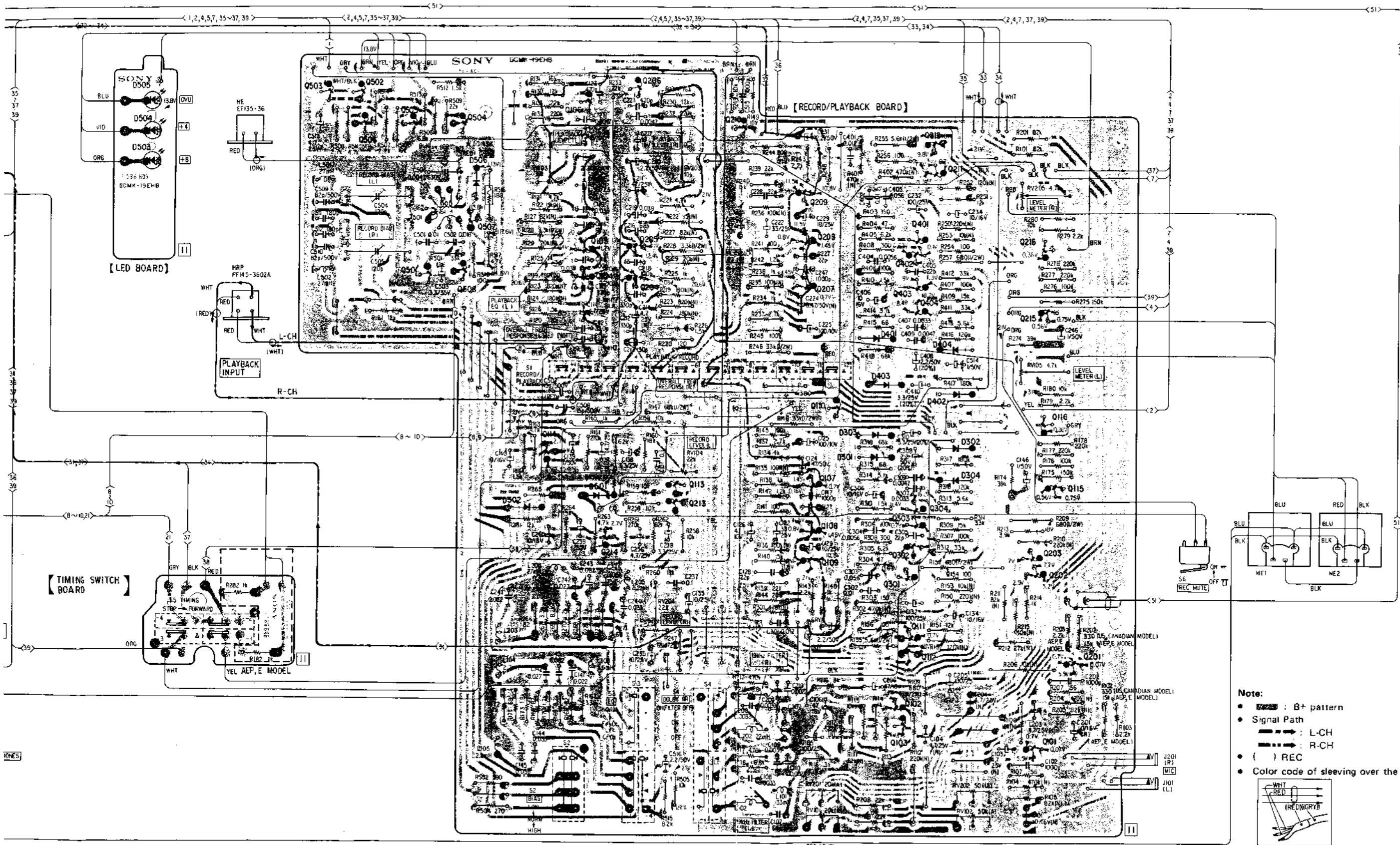

Note:

- : B+ pattern
- : Signal Path
- : L-CH
- : R-CH
- () REC
- Color code of sleeving over the end of the jacket.

503	502	505	504	114	106	206	113	210	209	107	110	301	401	304	212	203	216	
	506	501	508	507	105	205	213	210	208	108		102	402	303	211	202	215	
					104	204			207	109		103	403	302	404	101	116	115
505			506		502	501						401	404					
504												303	402					
503												301	302	304				

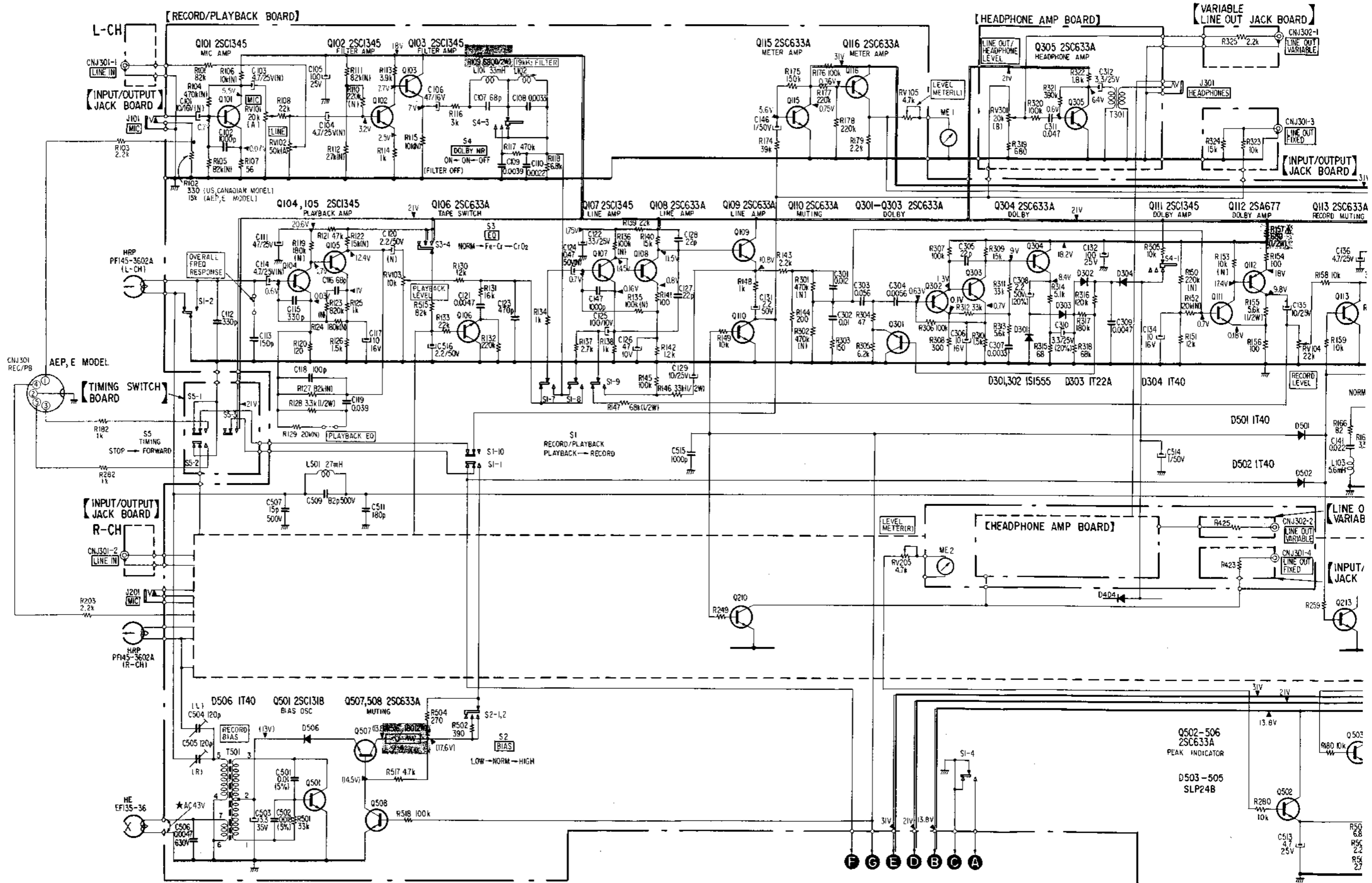

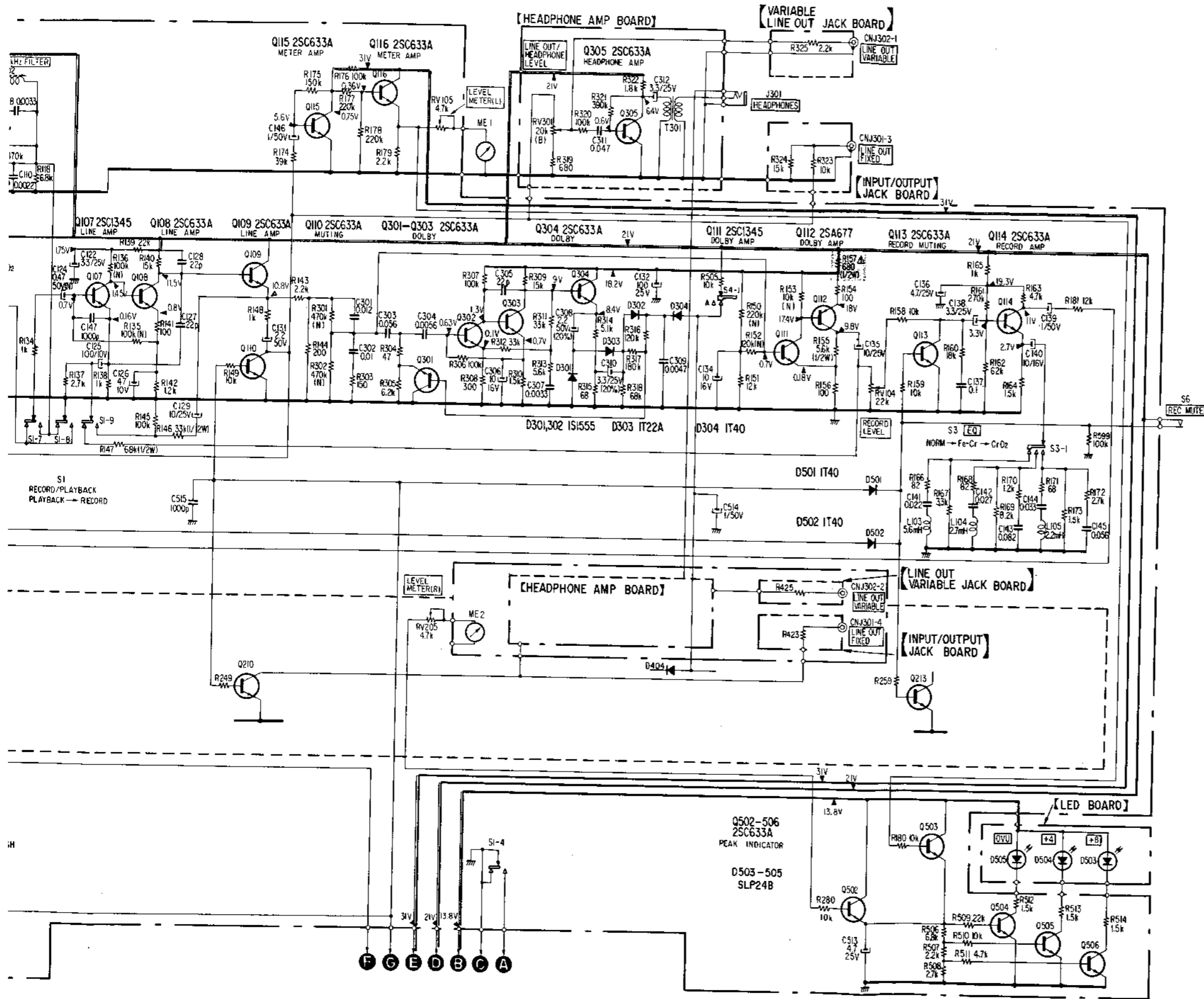

Notes:

- All capacitors are in μF unless otherwise noted. $\text{pF} = \mu\mu\text{F}$. 50WV or less are not indicated except for electrolytics.
- All resistors are in ohms, $\frac{1}{4}\text{W}$ unless otherwise noted. $\text{k}\Omega = 1000\Omega$, $\text{M}\Omega = 1000\text{k}\Omega$
- : fusible resistor.
- (N) : low-noise resistor and capacitor.
- 0% indicates component tolerance.
- : B+ bus.
- : panel designation.
- : adjustment for repair.
- Voltages are dc with respect to ground unless otherwise noted.
- Readings are taken under no signal conditions with a VOM (20 $\text{k}\Omega/\text{V}$).
- () : RECORD
- AC voltage readings indicated by * in the bias oscillator circuit are taken with a VTVM.
- Voltage variations may be noted due to normal production tolerances.
- Switch

Ref. No.	Switch	Position
S1-1 to S1-12	RECORD/PLAYBACK	PLAYBACK
S2	BIAS	LOW
S3-1, S3-2, S3-4	EQ	NORM
S4-1, S4-2, S4-4	DOLBY NR	OFF
S5-1 to S5-4	TIMING	STOP
S6	REC MUTE	OFF

Note: The components identified by shading and Δ mark are critical for safety. Replace only with part number specified.

- (1) Note:
- Items with no part number and/or no description are not stocked because they are seldom required for routine service.
 - All screws are Phillips (cross recess) type unless otherwise noted.
 - (-) = slotted head
 - Circled letters (A to Z) are applicable to European models only.

1
2
3
4

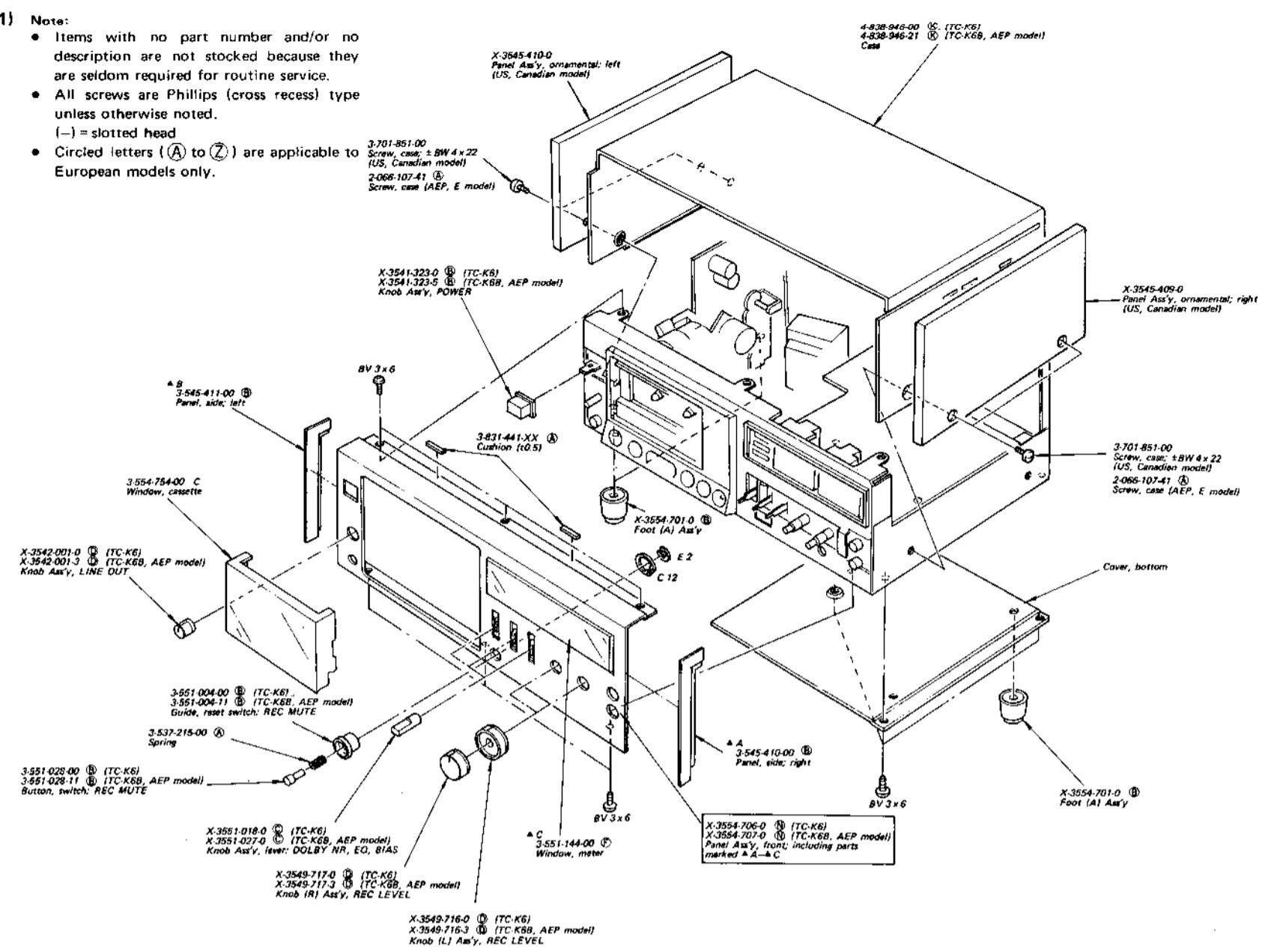

- (2) Note:
- Items with no part number and/or no description are not stocked because they are seldom required for routine service.
 - All screws are Phillips (cross recess) type unless otherwise noted.
 - (-) = slotted head
 - Circled letters (A to Z) are applicable to European models only.

1
2
3
4

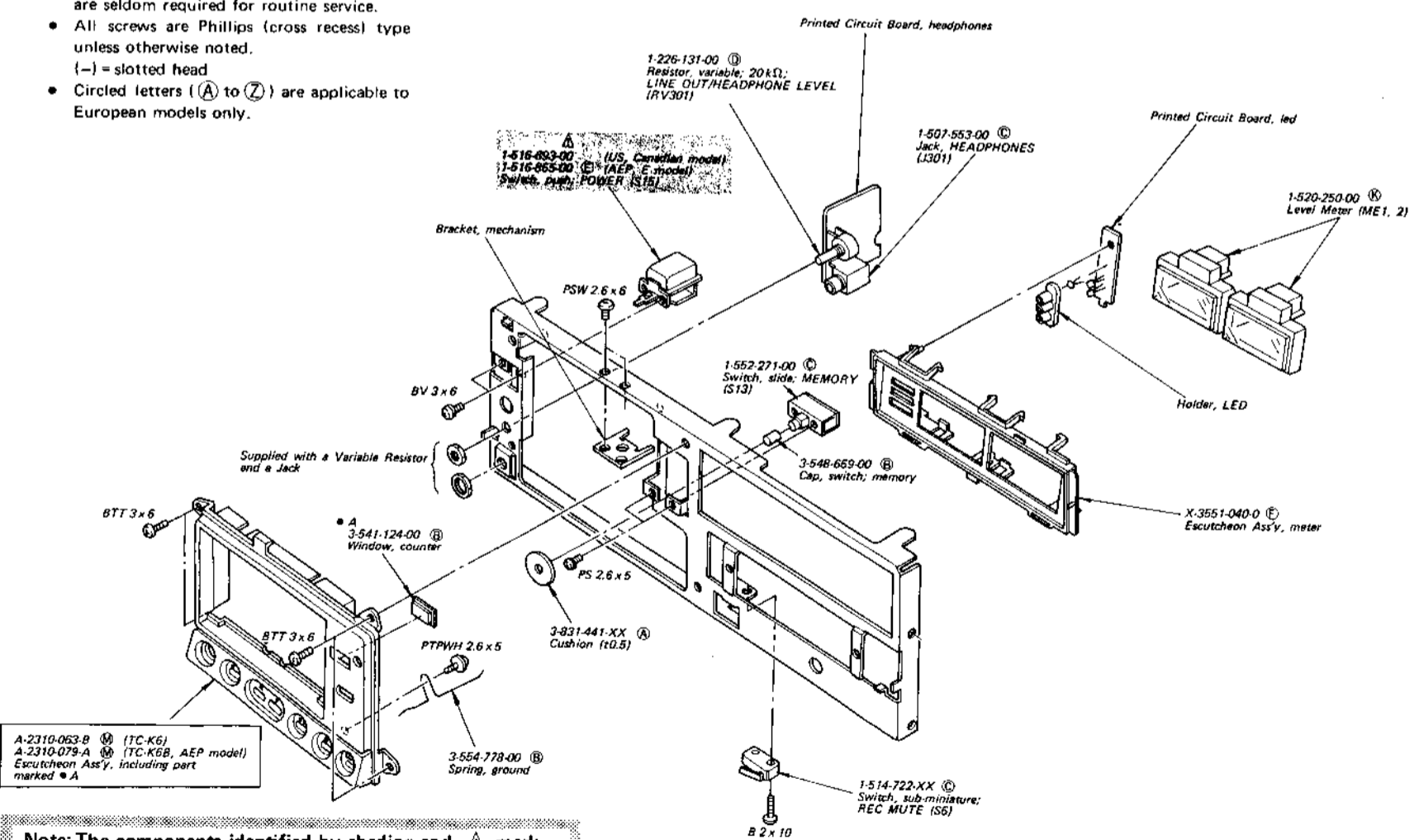

Note: The components identified by shading and ⚠ mark are critical for safety. Replace only with part number specified.

(3)

Note: The components identified by shading and ⚠ mark are critical for safety. Replace only with part number specified.

A

B

C

D

E

(4) Note:

- Items with no part number and/or no description are not stocked because they are seldom required for routine service.
- All screws are Phillips (cross recess) type unless otherwise noted.
[-] = slotted head
- (□□□) shows the number of coils in spring.
- Circled letters (A to Z) are applicable to European models only.

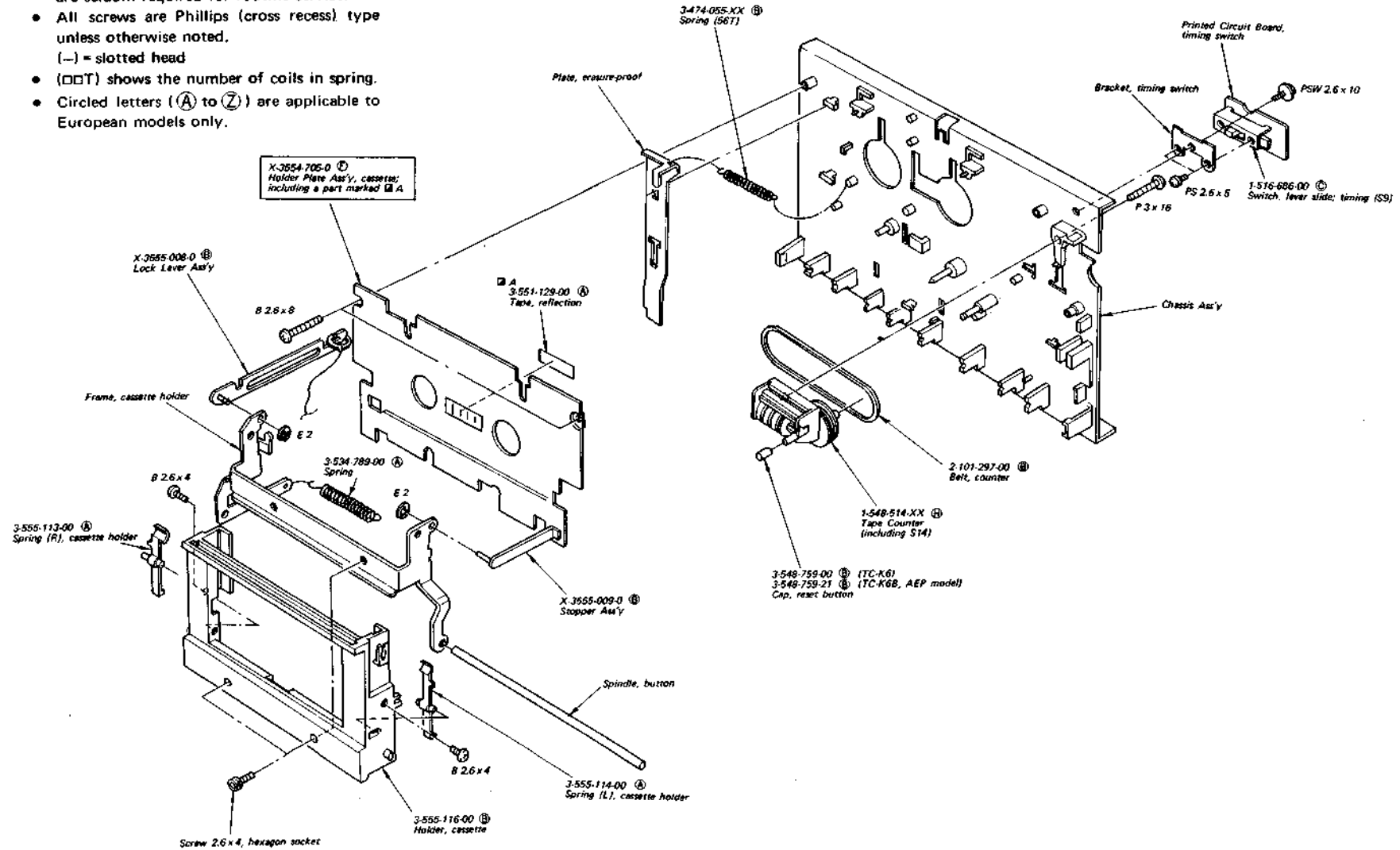

TC-K6/K6B

1

2

- 37 -

3

4

A B C D E

(5)

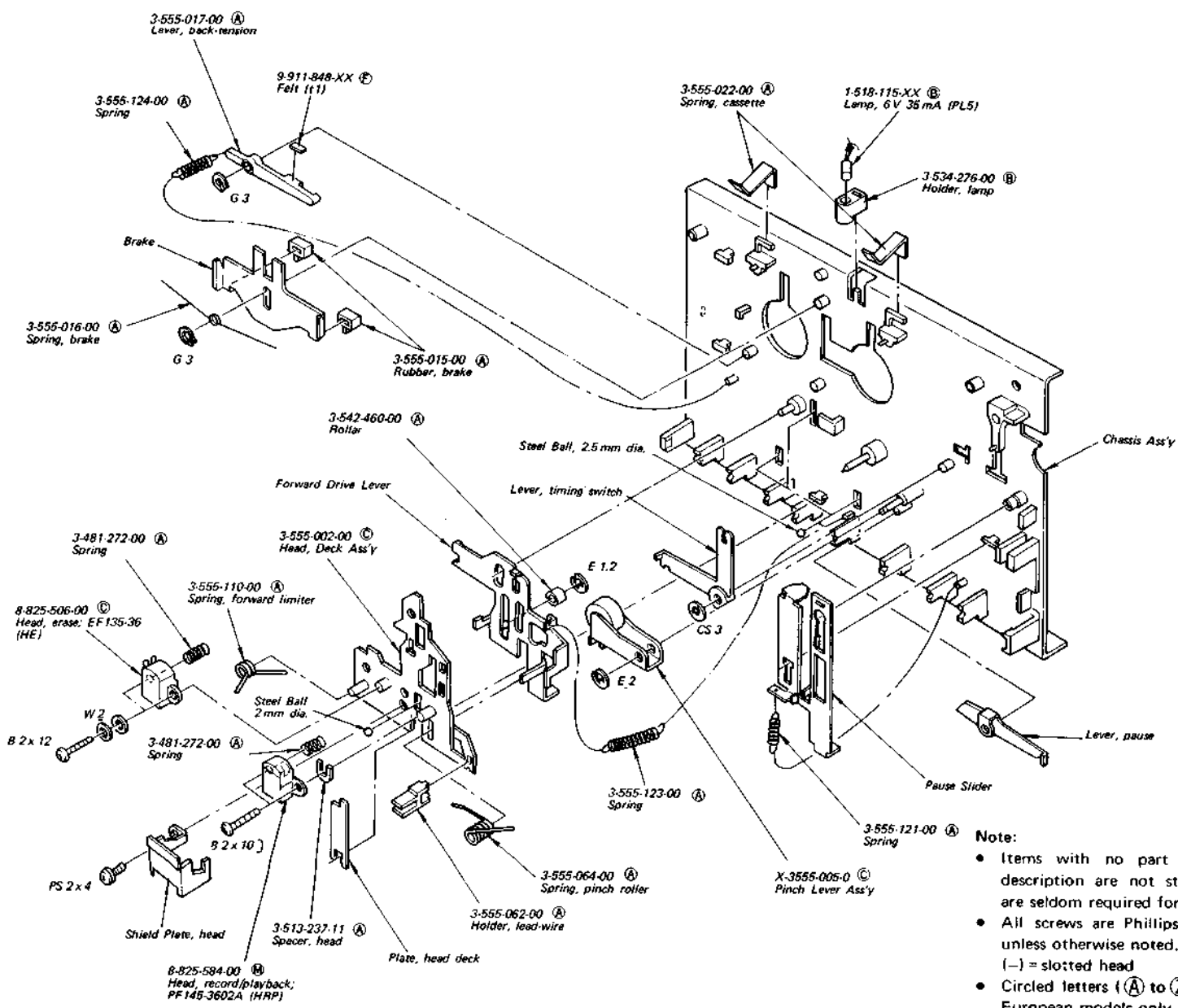

- Note:**
- Items with no part number and/or no description are not stocked because they are seldom required for routine service.
 - All screws are Phillips (cross recess) type unless otherwise noted.
(-) = slotted head
 - Circled letters (A to Z) are applicable to European models only.

38

1

2

3

4

A

B

C

D

E

(6)

3-554-707-00 ⓑ
Belt, deceleration

X.3554-703-0 ⓐ
Gear As'y

3-489-310-XX ⓐ
Spring

3-554-743-00 ⓑ
Plate, lock

Lever, switch actuate

3-554-783-00 ⓐ
Spring, lock plate

3-554-705-00 ⓐ
Pulley

3-554-749-00 ⓑ
Plate, record lock

3-554-746-00 ⓑ
Lever, pause

PS 2.6 x 6

3-554-709-00 ⓐ
Cushion, rubber

Screw, 2.6 x 6

1-541-129-00 ⓑ
Motor, function (M2)

3-492-141-XX ⓐ
Spring (28T)

Shaft, lock plate guide

3-554-725-00 ⓐ
Link, eject

PS 2.6 x 4

3-554-706-00 ⓑ
Pulley, motor

Shield Cover, motor

Plate, motor holder

3-554-723-00 ⓐ
Lever, eject shift

E 2.3

Motor Holder As'y

Shaft, gear

3-554-780-00 ⓐ
Case, motor

PS 2.6 x 4

Fulcrum Plate, gear

3-613-172-XX ⓐ
Spring (31T)

3-554-751-00 ⓐ
Tip, trigger

Slider, eject

3-554-703-00 ⓑ
Lever, shift

3-554-403-00 ⓐ
Pivot

PS 2.6 x 4

3-554-703-00 ⓑ
Lever, shift

3-554-720-00 ⓐ
Lever, fast forward and rewind trigger

3-554-731-00 ⓑ
Lever, forward shift

3-554-747-00 ⓐ
Lever, record and forward trigger

3-554-703-00 ⓑ
Lever, shift

3-554-720-00 ⓐ
Lever, fast forward and rewind trigger

3-554-702-00 ⓑ
Lever (B), record shift

3-554-747-00 ⓐ
Lever, record and forward trigger

3-554-703-00 ⓑ
Lever, shift

Shaft, shift lever

3-554-750-00 ⓐ
Gear (A)

3-554-745-00 ⓑ
Gear (B)

3-545-403-00 ⓐ
Pivot

Holder, thrust

Note:

- Items with no part number and/or no description are not stocked because they are seldom required for routine service.
- All screws are Phillips (cross recess) type unless otherwise noted.
- (-) = slotted head
- (□T) shows the number of coils in spring.
- Circled letters (A) to (Z) are applicable to European models only.

1

2

39

3

4

TC-K6/K6B

(7)

A B C D E

1

2

40

3

4

Note:

- Items with no part number and/or no description are not stocked because they are seldom required for routine service.
- All screws are Phillips (cross recess) type unless otherwise noted.
- (-) = slotted head
- (□□) shows the number of coils in spring.
- Circled letters (A) to (Z) are applicable to European models only.

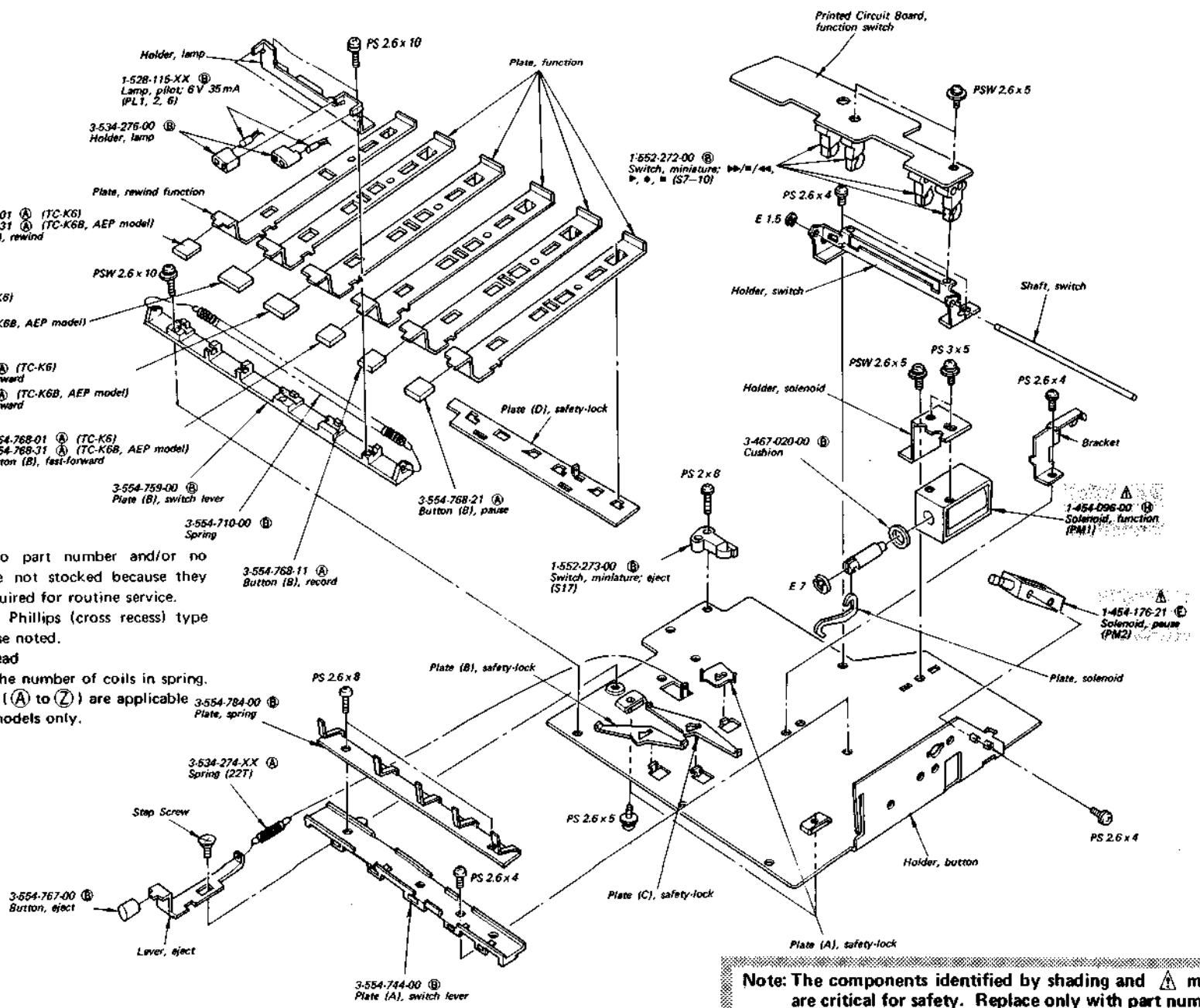

Note: The components identified by shading and mark are critical for safety. Replace only with part number specified.

A

B

C

D

E

(B) Note:

- Items with no part number and/or no description are not stocked because they are seldom required for routine service.
- All screws are Phillips (cross recess) type unless otherwise noted.
(-) = slotted head
- Circled letters (A) to (Z) are applicable to European models only.

1

2

3

4

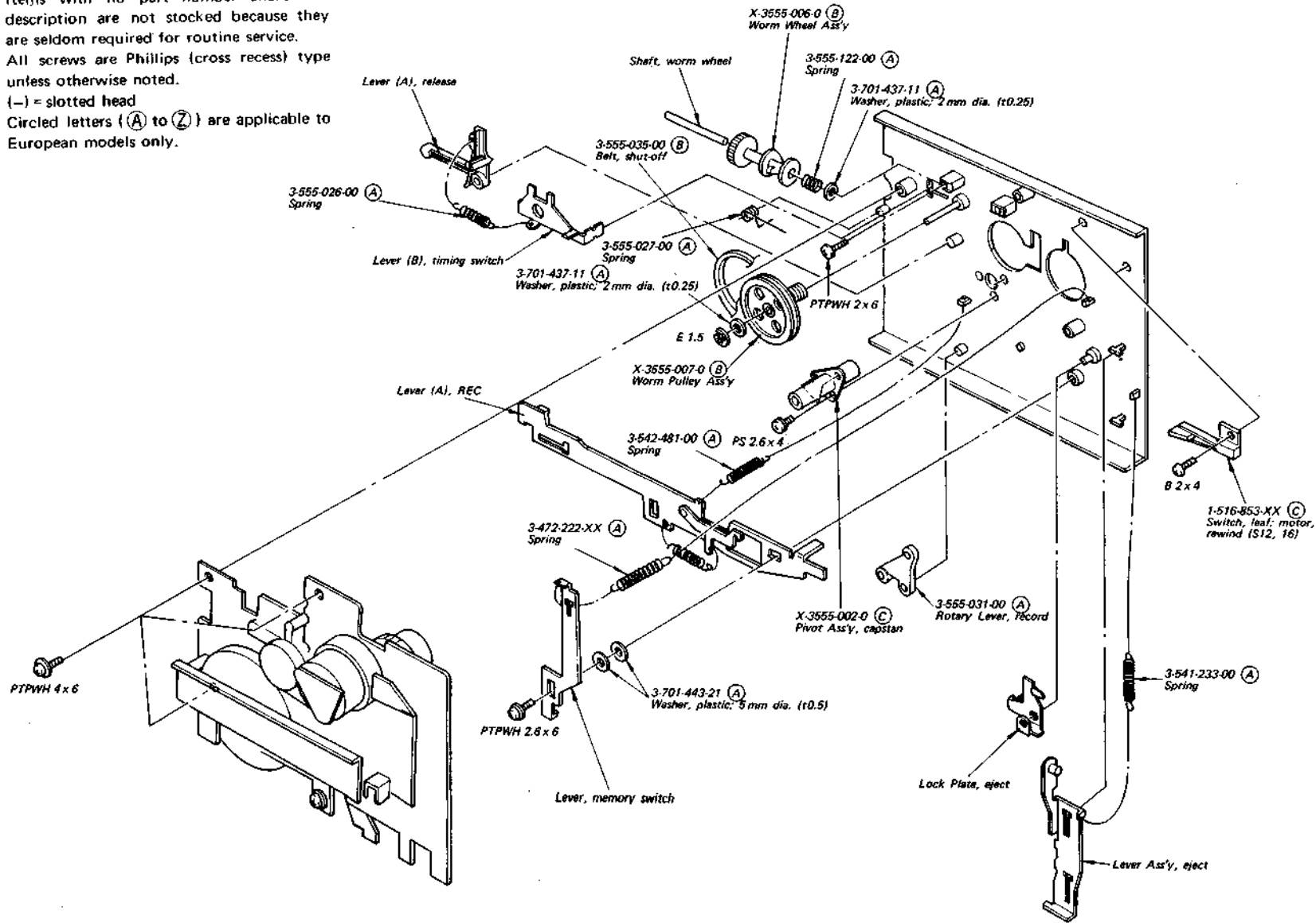

TC-K6/K6B

A B C D E

(9) Note:

- Items with no part number and/or no description are not stocked because they are seldom required for routine service.
- All screws are Phillips (cross recess) type unless otherwise noted.
(-) = slotted head
- Circled letters (A) to (Z) are applicable to European models only.

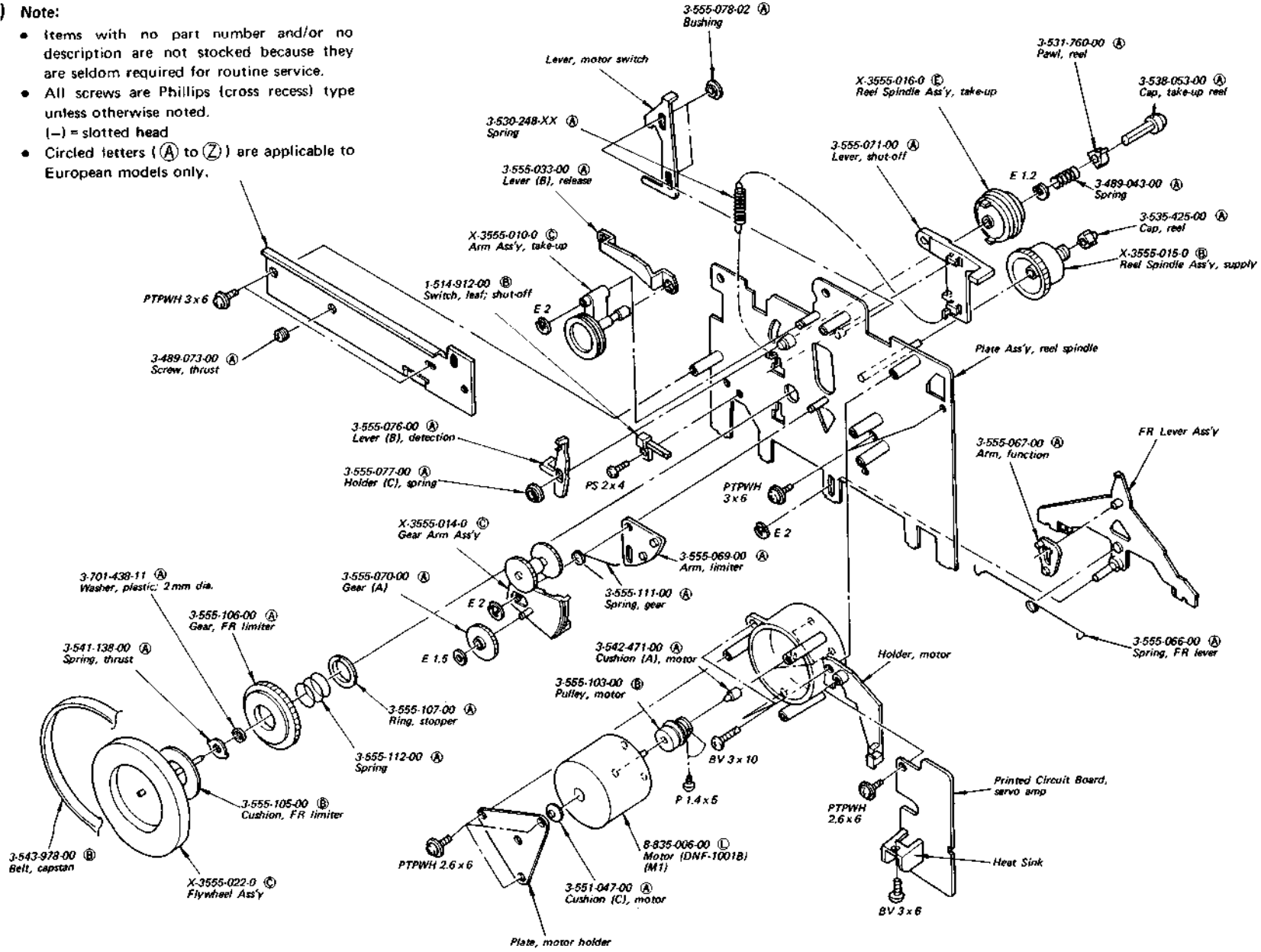

1

2

- 42 -

3

4

**SECTION 6
ELECTRICAL PARTS LIST**

• Circled letters (A to Z) are applicable to European models only.

<u>Ref. No.</u>	<u>Part No.</u>	<u>Description</u>	<u>Ref. No.</u>	<u>Part No.</u>	<u>Description</u>
SEMICONDUCTORS					
Transistors					
Q101-105	(B) 2SC1345		Q621	(B) 2SC634A	
⇒ Q106	(B) 2SC634A		⇒ Q1001	(D) 2SC1061	
Q107	(B) 2SC1345			IC	
⇒ Q108-110	(B) 2SC634A		⇒ IC1001	(F) CX065A	
Q111	(B) 2SC1345			Diodes	
⇒ Q112	(C) 2SA678		D301,302	(B) 1S1555	
⇒ Q113-116	(B) 2SC634A		D303	(B) 1T22AM	
Q201-205	(B) 2SC1345		⇒ D304	(B) 1S1555	
⇒ Q206	(B) 2SC634A		D401,402	(B) 1S1555	
Q207	(B) 2SC1345		D403	(B) 1T22AM	
⇒ Q208-210	(B) 2SC634A		⇒ D404	(B) 1S1555	
Q211	(B) 2SC1345		⇒ D501,502	(B) 1S1555	
⇒ Q212	(C) 2SA678		D503-505	(C) SLP24B	
⇒ Q213	(B) 2SC634A		⇒ D506	(B) 1S1555	
⇒ Q224-226	(B) 2SC634A		⇒ D601-616	(B) 1S1555	
⇒ Q301-305	(B) 2SC634A		⇒ D617	(B) EQB01-12Z	
⇒ Q401-405	(B) 2SC634A		⇒ D618,619	(A) (B) 10E2	
⇒ Q501	(C) 2SC1475		⇒ D620,621	(B) 1S1555	
⇒ Q502-508	(B) 2SC634A		⇒ D622	(B) EQB01-08	
Q601,602	(B) 2SC634A		⇒ D623	(B) 10E2	
Q603	(C) 2SC1475		⇒ D624,626	(A) 10E2 (US, Canadian model)	
Q604-606	(B) 2SC634A		⇒ D625,627	(A) (B) 10E2	
Q607	(C) 2SC1475		⇒ D628,629	(B) 10E2	
Q608,609	(B) 2SC634A		⇒ D630,631	(B) 1S1555	
Q610	(C) 2SA678			COILS	
Q611-616	(B) 2SC634A		L101,201	1-407-212-XX (B) 33μH	
Q617	(C) 2SC1475		L102,202	1-407-240-00 (B) Inductor, variable; 19 kHz FILTER	
Q618	(B) 2SC634A		L103,203	1-407-203-XX (B) 5.6 mH	
Q619,620	(C) 2SC1173		L104,204	1-407-199-XX (B) 2.7 mH	
			L105,205	1-407-198-XX (B) 2.2 mH	
			L501,502	1-407-211-XX (B) 27μH	

⇒: Due to standardization, interchangeable replacements may be substituted for parts specified in the diagrams.

Note: The components identified by shading and ⚠ mark are critical for safety. Replace only with part number specified.

TC-K6/K6B

- Circled letters (A to Z) are applicable to European models only.

<u>Ref. No.</u>	<u>Part No.</u>	<u>Description</u>
TRANSFORMERS		
T1	▲ 1-446-009-00	Power (US, Canadian model)
T1	▲ 1-446-010-00	(N) Power (AEP, E model)

T301,401 1-427-424-00 **(C)** Output

T501 1-433-132-00 **(C)** OSC

CAPACITORS

All capacitors are in μF and ceramic unless otherwise noted.

50WV or less are not indicated except for electrolytics. pF = μF , elect = electrolytic

C101,201	1-121-916-11	(B) 10	16V	elect
C102,202	1-102-074-11	(A) 0.001		
C103,203 C104,204	1-121-915-11	(A) 4.7	25V	elect
C105,205	1-121-416-11	(B) 100	25V	elect
C106,206	1-121-409-11	(A) 47	16V	elect
C107,207	1-101-888-11	(A) 68p		
C108,208	1-108-567-12	(A) 0.0033		mylar
C109,209	1-108-569-12	(B) 0.0039		mylar
C110,210	1-108-563-11	(B) 0.0022		mylar
C111,211	1-121-410-11	(B) 47	25V	elect
C112,212	1-102-820-11	(A) 330p		
C113,213	1-102-108-11	(A) 150p		
C114,214	1-121-915-11	(A) 4.7	25V	elect
C115,215	1-102-820-11	(A) 330p		
C116,216	1-101-888-11	(A) 68p		
C117,217	1-121-651-11	(A) 10	16V	elect
C118,218	1-102-106-11	(A) 100p		
C119,219	1-108-593-12	(B) 0.039		mylar
C120,220	1-123-050-11	(B) 2.2	50V	elect
C121,221	1-108-571-12	(A) 0.0047		mylar
C122,222	1-121-404-11	(A) 33	25V	elect
C123,223	1-102-114-11	(A) 470p		
C124,224	1-121-911-11	(B) 0.47	50V	elect
C125,225	1-121-414-11	(A) 100	10V	elect
C126,226	1-121-352-11	(A) 47	10V	elect

<u>Ref. No.</u>	<u>Part No.</u>	<u>Description</u>	
C127,227	1-102-959-11	(A) 22p	
C128,228	1-102-959-11	(A) 22p	
C129,229	1-121-398-11	(A) 10	25V elect
C131,231	1-121-450-11	(A) 2.2	50V elect
C132, 232	1-121-416-11	(B) 100	25V elect
C134,234	1-121-651-11	(A) 10	16V elect
C135,235	1-121-398-11	(A) 10	25V elect
C136,236	1-121-395-11	(A) 4.7	25V elect
C137,237	1-108-251-12	(B) 0.1	mylar
C138,238	1-121-392-11	(A) 3.3	25V elect
C139,239	1-121-391-11	(A) 1	50V elect
C140,240	1-121-651-11	(A) 10	16V elect
C141,241	1-108-587-12	(A) 0.022	mylar
C142,242	1-108-589-12	(B) 0.027	mylar
C143,243	1-108-362-12	(B) 0.082	mylar
C144,244	1-108-591-12	(B) 0.033	mylar
C145,245	1-108-361-12	(A) 0.056	mylar
C146,246	1-121-391-11	(A) 1	50V elect
C147,247	1-102-074-11	(A) 0.001	
C301,401	1-108-581-12	(B) 0.012	mylar
C302,402	1-108-579-12	(A) 0.01	mylar
C303,403	1-108-597-12	(B) 0.0056	mylar
C304,404	1-108-573-12	(A) 0.0056	mylar
C305,405	1-102-959-11	(A) 22p	
C306,406	1-121-651-11	(A) 10	16V elect
C307,407	1-108-567-12	(A) 0.0033	mylar
C308,408	1-121-986-11	(A) 2.2	50V elect
C309,409	1-108-234-12	(A) 0.0047	mylar
C310,410	1-121-960-11	(A) 3.3	25V elect
C311,411	1-108-246-12	(A) 0.047	mylar
C312,412	1-121-392-11	(A) 3.3	25V elect
C501	1-108-579-12	(A) 0.01	mylar
C502	1-108-585-12	(B) 0.018	mylar
C503	1-131-218-11	(B) 3.3	35V tantalum
C504,505	1-141-010-XX	(B) Trimmer	
C506	1-129-710-11	(A) 0.0047	630V film
C507,508	1-107-206-11	(A) 15p	500V silvered mica
C509,510	1-107-037-11	(A) 82p	500V silvered mica
C511,512	1-107-091-11	(A) 180p	silvered mica

Note: The components identified by shading and ▲ mark are critical for safety. Replace only with part number specified.

• Circled letters (A) to (Z) are applicable to European models only.

Ref. No.	Part No.	Description
C513	1-121-395-11 (A) 4.7	25 V elect
C514	1-121-391-11 (A) 1	50 V elect
C515	1-102-074-11 (A) 0.001	
C516	1-121-450-11 (A) 2.2	50 V elect
C601	1-121-395-11 (A) 4.7	25 V elect
C602	1-121-391-11 (A) 1	50 V elect
C603	1-121-409-11 (A) 47	16 V elect
C604	1-121-450-11 (A) 2.2	50 V elect
C605	1-121-395-11 (A) 4.7	25 V elect
C606	1-121-662-11 (A) 22	35 V elect
C607,608	1-121-391-11 (A) 1	50 V elect
C609	1-121-392-11 (A) 3.3	25 V elect
C610	1-161-025-11 (B) 0.1	(boundary layer)
C611	1-161-019-11 (A) 0.033	(boundary layer)
C612,613	1-161-025-11 (B) 0.1	(boundary layer)
C614	1-161-019-11 (A) 0.033	(boundary layer)
C615	1-121-726-11 (A) 0.47	50 V elect
C616	1-121-398-11 (A) 10	25 V elect
C617	1-121-479-11 (A) 22	16 V elect
C618	1-121-416-11 (B) 100	25 V elect
C619	1-121-361-11 (B) 470	35 V elect
C620	1-121-361-11 (B) 470	35 V elect
C621	1-121-392-11 (A) 3.3	25 V elect
C622	1-121-660-11 (B) 2200	16 V elect
C623	1-121-479-11 (A) 22	16 V elect
C624	1-121-245-11 (B) 1000	16 V elect
C625	1-121-398-11 (A) 10	25 V elect
C626	1-121-245-11 (B) 1000	16 V elect
C627	1-121-392-11 (A) 3.3	25 V elect
C1003	1-130-134-11 (B) 0.08	100 V film

RESISTORS

All resistors are in ohms. Common 1/4W carbon resistors are omitted. Refer to the list on page 21 for their part numbers.

R109,209	1-244-869-11 (A) 580	1/2 W carbon
R157,257	1-244-869-11 (A) 580	1/2 W carbon

Ref. No.	Part No.	Description
R516	1-217-402-11 (B) 180	1/4 W fusible
R649	1-244-873-11 (A) 1k	1/4 W carbon
R650	1-245-413-11 (A) 2.2	1/4 W carbon
R654	1-244-411-11 (A) 2.2	1/4 W carbon
R655	1-206-431-11 (A) 56	1/2 W metal film
R656	1-244-867-11 (A) 560	1/2 W carbon
R657	1-217-418-11 (A) 0.47	1/2 W fusible
RV101,201	1-226-132-00 (D) 20 k (A), variable; REC LEVEL MIC	
RV102,202	1-226-130-00 (E) 50 k (A), variable; REC LEVEL LINE	
RV103,203	1-224-645-XX (B) 10 k, adjustable; playback level	
RV104,204	1-224-646-XX (B) 22 k, adjustable; record level	
RV105,205	1-224-644-XX (B) 4.7, adjustable; level meter (L), (R)	
RV301	1-226-131-00 (D) 20 k, variable; LINE OUT/ HEADPHONE LEVEL	
RV1001	1-224-491-00 (B) 22 k, adjustable; tape speed	

SWITCHES

S1	1-516-263-00 (D) Slide, record/playback
S2	1-552-039-00 (C) Lever Slide, BIAS
S3,4	1-552-038-00 (D) Lever Slide (S3: EQ, S4: DOLBY NR)
S5	1-516-686-00 (C) Lever Slide, timing
S6	1-514-722-XX (C) Sub-miniature, REC MUTE
S7-10	1-552-272-00 (B) Miniature, >>/>/<</<<, >, <, >, <
S11	1-514-912-00 (B) Leaf, shut-off
S12	1-516-853-XX (C) Leaf, rewind
S13	1-552-271-00 (C) Slide, MEMORY
S15	1-516-692-00 (E) Push, POWER (US, Canadian models)
S15	1-516-853-00 (E) Push, POWER (AEP, E model)
S16	1-516-853-XX (C) Leaf, motor
S17	1-552-273-00 (B) Miniature, eject

Note: The components identified by shading and Δ mark are critical for safety. Replace only with part number specified.

TC-K6/K6B

- Circled letters (A) to (Z) are applicable to European models only.

<u>Ref. No.</u>	<u>Part No.</u>	<u>Description</u>
JACKS AND CONNECTORS		
J101,201	1-507-525-00	(D) Jack, MIC
J301	1-507-553-00	(C) Jack, HEADPHONES
CNJ4	△ 1-526-528-00	Socket, ac outlet (US, Canadian model)
CNJ301	1-507-531-21	Plate, pin jack; LINE IN, OUT (US, Canadian model)
CNJ301	1-536-501-21	(D) Plate, pin jack; LINE IN, OUT, REC/PB (AEP, E model)
CNJ302	1-507-526-21	(B) Jack, 2p; VARIABLE LINE OUT

MISCELLANEOUS

CP1	△ 1-231-057-31	(B) CR Encapsulated Component (AEP, E model)
CP1	△ 1-231-326-11	CR Encapsulated Component (US model)
CP1	△ 1-231-341-21	CR Encapsulated Component (Canadian model)
F1	△ 1-532-235-00	(B) Fuse, T315 mA (AEP, E model)
F2,3	△ 1-532-285-00	(B) Fuse, T1.25 A (AEP, E model)
HE	8-825-506-00	(C) Head, erase EF135-36
HRP	8-825-584-00	(M) Head, record/playback; PF145-3602A
M1	8-835-006-00	(L) Motor, capstan; DNF-1001B
M2	1-541-129-00	(H) Motor, function
ME1,2	1-520-250-00	(K) Level Meter
PL1,2,5,6	1-518-115-XX	(B) Lamp, pilot 6 V 35 mA
PM1	△ 1-454-096-00	(H) Solenoid, function
PM2	△ 1-454-176-21	(E) Solenoid, pause
	△ 1-509-546-00	(D) Connector, 3-p ac in (AEP, E model)
	△ 1-534-538-XX	Cord, power (US model)
	△ 1-534-986-XX	Cord, power (Canadian model)
	1-548-514-XX	(H) Tape Counter
	△ 1-552-026-00	(E) Voltage Selector (AEP, E model)

ACCESSORIES & PACKING MATERIALS

<u>Part No.</u>	<u>Description</u>
X-3549-745-0	(C) Cushion Ass'y
X-3701-105-0	(A) Tips Ass'y, head cleaning
1-534-049-31	(F) Cord, connector; RK-74H
1-534-754-00	△ (E) Cord, power; parallel-blade plug (E model)
1-551-216-11	△ (H) Cord, power; euro-plug (E model)
3-429-126-00	(B) Bag, plastic
3-554-790-00	(F) Carton (TC-K6B, AEP model)
3-554-791-00	Carton (US, Canadian model)
3-554-792-00	(E) Carton (AEP, E model)
3-701-630-00	(A) Bag, plastic
3-770-365-11	(F) Manual, instruction (AEP, E model)
3-770-365-21	Manual, instruction (US model)
3-770-365-21	Manual, instruction (Canadian model)
3-794-172-31	Warranty Card (Canadian model)
3-793-956-31	Warranty Card (Canadian model)
3-794-060-11	(B) Leaflet (AEP, E model)
4-837-003-00	(C) Bag, plastic (TC-K6B, AEP model)

Note: The components identified by shading and △ mark are critical for safety. Replace only with part number specified.

Sony Corporation

© 1978

— 46 —