

TC-K4A

*AEP Model
UK Model
Canadian Model
US Model
E Model*



(AEP, UK, E model)

STEREO CASSETTE DECK

SPECIFICATIONS

SAFETY RELATED COMPONENT WARNING!!

COMPONENTS IDENTIFIED BY SHADING AND MARK Δ ON THE SCHEMATIC DIAGRAMS, EXPLODED VIEWS AND IN THE PARTS LIST ARE CRITICAL TO SAFE OPERATION. REPLACE THESE COMPONENTS WITH SONY PARTS WHOSE PART NUMBERS APPEAR AS SHOWN IN THIS MANUAL OR IN SUPPLEMENTS PUBLISHED BY SONY.

ATTENTION AU COMPOSANT AYANT RAPPORT A LA SÉCURITÉ !

LES COMPOSANTS IDENTIFIÉS PAR UN TRAMÉ ET UNE MARQUE Δ SUR LES DIAGRAMMES SCHÉMATIQUES, LES VUES EXPLOSÉES ET LA LISTE DES PIÈCES SONT CRITIQUES POUR LA SÉCURITÉ DE FONCTIONNEMENT. NE REMPLACER CES COMPOSANTS QUE PAR DES PIÈCES SONY DONT LES NUMÉROS SONT DONNÉS DANS CE MANUEL OU DES SUPPLÉMENTS PUBLIÉS PAR SONY.

'Dolby' and the double-D symbol are the trade marks of Dolby Laboratory Inc. Noise reduction system manufactured under license from Dolby Laboratory Inc.

Power Requirements:	120V ac, 60Hz (US, Canadian model) 110, 120, 220 or 240V ac adjustable, 50/60Hz (AEP, UK, E model)
Power Consumption:	9W
Dimensions:	Approx. 435(w) x 145(h) x 260(d) mm 17 $\frac{1}{8}$ (w) x 5 $\frac{3}{8}$ (h) x 10 $\frac{1}{4}$ (d) inches (US, Canadian model) Approx. 410(w) x 145(h) x 260(d) mm 16 $\frac{1}{8}$ (w) x 5 $\frac{3}{8}$ (h) x 10 $\frac{1}{4}$ (d) inches (AEP, UK, E model) including projecting parts and controls
Weight:	Approx. 6.3kg, 13 lb 14 oz (US, Canadian model) Approx. 5.7kg, 12 lb 10 oz (AEP, UK, E model)
Track:	4-track 2-channel stereo
Fast Forward and Rewind Time:	Approx. 90 sec. (with C-60)

— Continued on page 2 —

SONY
SERVICE MANUAL

276

TC-K4A

Frequency Response: DOLBY NR OFF

- With Ferri-Chrome cassette
20–17,000Hz (NAB)
30–15,000Hz ± 3 dB (NAB)
30–15,000Hz (DIN)
- With chromium dioxide cassette
20–17,000Hz (NAB)
30–15,000Hz ± 3 dB (NAB)
30–15,000Hz (DIN)
- With standard cassette
20–14,000Hz (NAB)
30–13,000Hz (DIN)

Wow and Flutter: 0.06% WRMS (NAB)
±0.16% (DIN)

S/N Ratio: DOLBY NR OFF

- With Ferri-Chrome cassette
58 dB at peak level (NAB)
56 dB (DIN)
- With chromium dioxide cassette
54 dB at peak level (NAB)

DOLBY NR ON
Improved by 5 dB at 1 kHz,
10 dB above 5 kHz

Total Harmonic

Distortion: 1.3%

Recording Bias

Frequency: 105 kHz

Inputs: Microphone inputs (phone jacks) 2
sensitivity 0.25mV (–70 dB)
for a low-impedance microphone

Line inputs (phono jacks) 2
sensitivity 77.5 mV (–20 dB)
input impedance 50 kΩ

Outputs: Line outputs (phono jacks) 2
output level 0.435V (–5 dB)
at load impedance 100 kΩ
suitable load impedance more than
10kΩ

Headphone output 1
output level 28 dB
at load impedance 8Ω

Record/playback Jack: Input impedance less than 10 kΩ
(AEP, UK, E model) Output impedance less than 10 kΩ

0 dB = 0.775V

MODEL IDENTIFICATION

– Specification Label –

US, Canadian Model

SONY	TAPECORDER MODEL NO. TC-K4A AC 120V ~60Hz 9W
	SERIAL NO.

AEP, UK, E Model

SONY	TAPECORDER MODEL NO. TC-K4A ACHO.120,220,240V ~50/60Hz 9W
	SERIAL NO.

SECTION 1
OUTLINE

BLOCK DIAGRAM

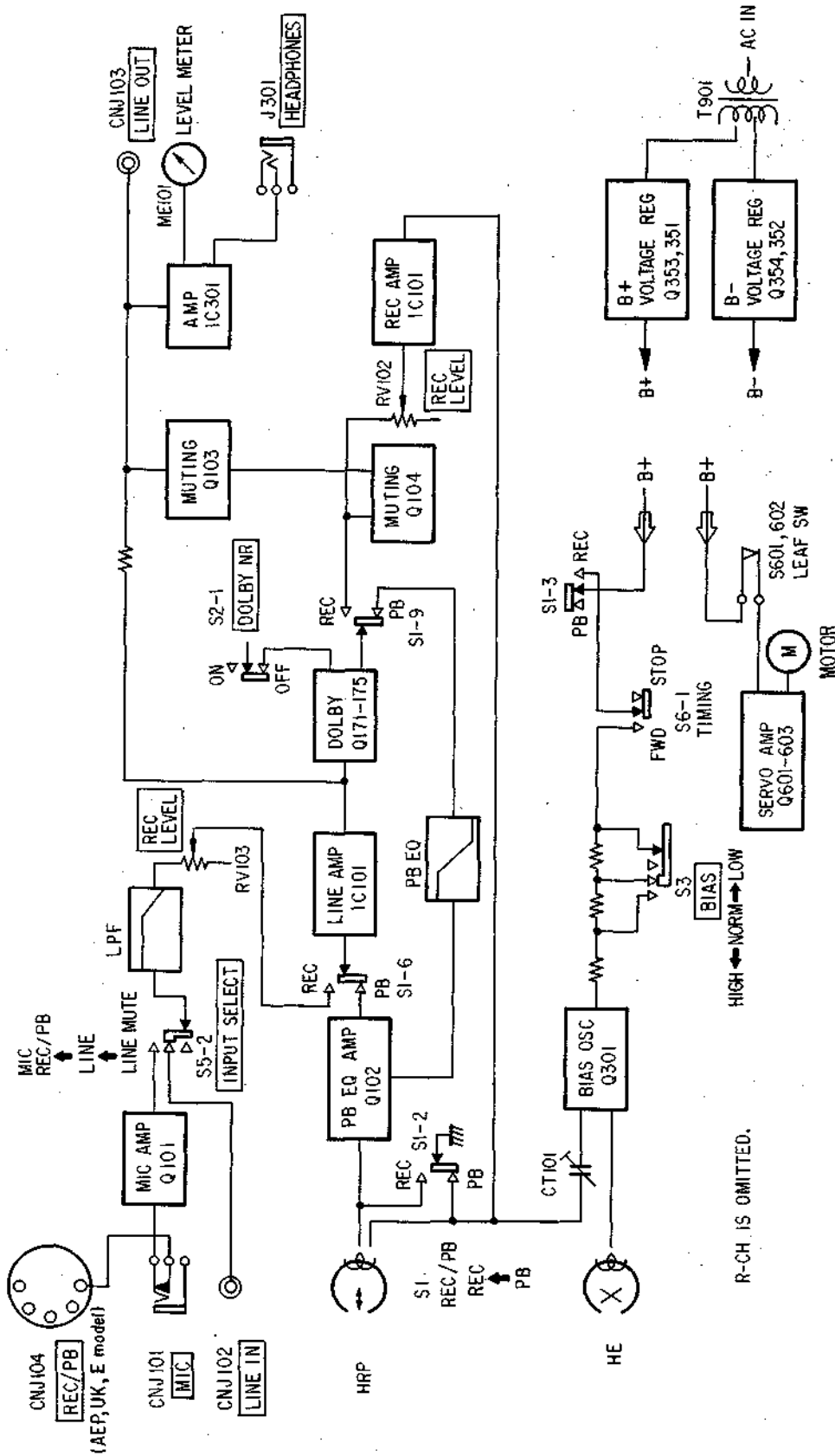

R-CH IS OMITTED.

**SECTION 2
DISASSEMBLY**

- Follow the disassembly procedure in the numerical order given.

[Top Cover Removal]

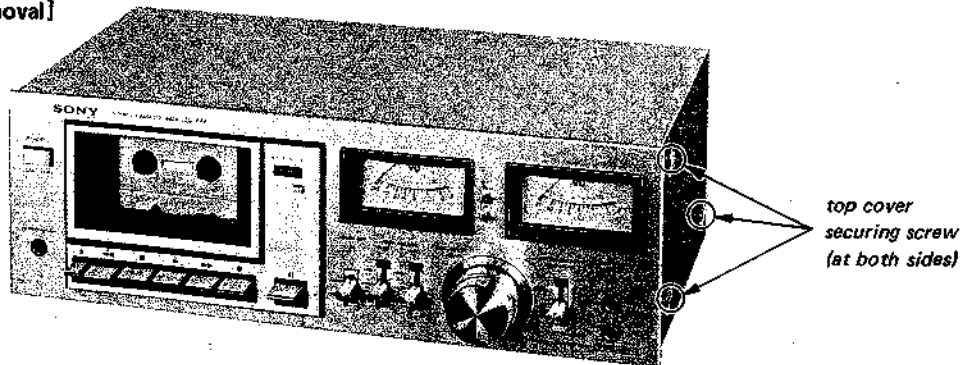

[Cassette Holder Lid Removal]

- ① Push the EJECT button.

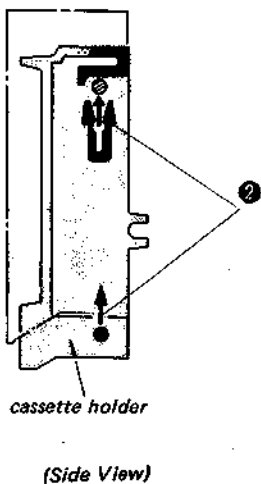

[Cassette Holder Removal]

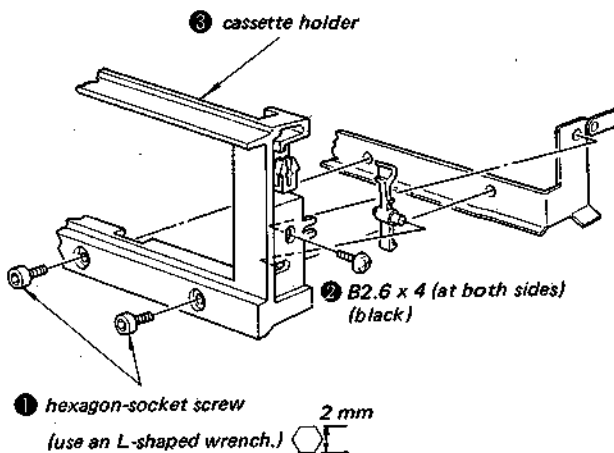

[Front Panel Removal]

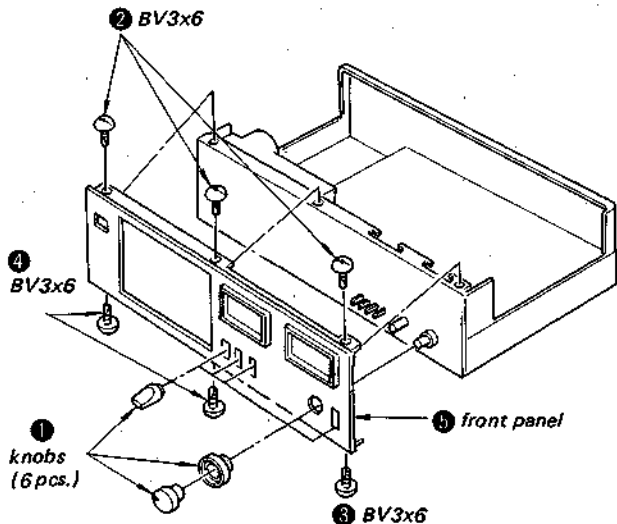

[Chassis Removal]

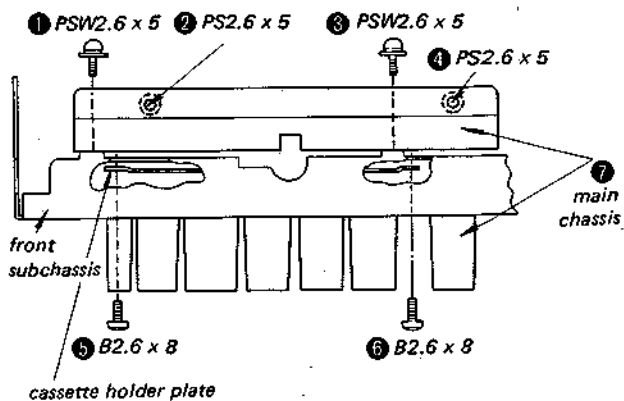

SECTION 3
ADJUSTMENTS

PRECAUTION

- Clean the following parts with a denatured-alcohol-moistened swab:

record/playback head	pinch roller
erase head	rubber belts
capstan	idlers
- Demagnetize the record/playback head with a head demagnetizer.
- Do not use a magnetized screwdriver for the adjustments.
- After the adjustments, apply suitable locking compound to the parts adjusted.
- The adjustments should be performed with the rated power supply voltage unless otherwise noted.

3-1. MECHANICAL ADJUSTMENTS

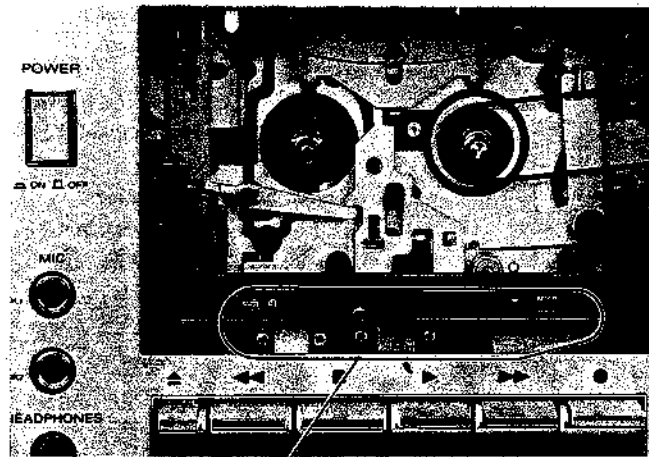

[Head Height Adjustment]
— Forward Mode —

- Make an adjustment tape cassette as shown and insert it in the set.

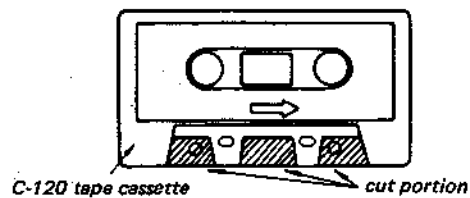

- Make sure that the tape is not twisted and slackened along the tape path.
- When the tape is twisted near the rec/pb head, change the adjustment washer.

- When the tape is twisted near the erase head adjust the erase head securing screw as shown.
- Apply suitable locking compound to the adjusted parts.

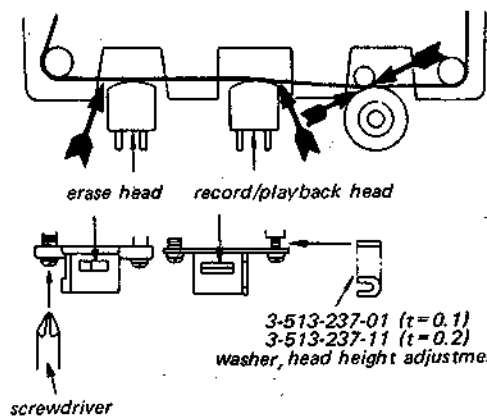

[Back-tension Torque Adjustment]
— Forward Mode —

- Place the type CQ-102A cassette torque meter in the set.
- Adjust the spring-hook position for specified torque.

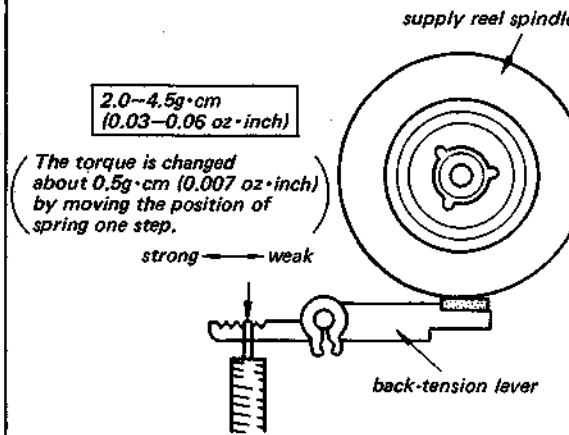

[Forward Torque Adjustment]
— Forward Mode —

- Place the type CQ-102A cassette torque meter in the set.
- Adjust the position of the adjustment spring catch for specified torque.

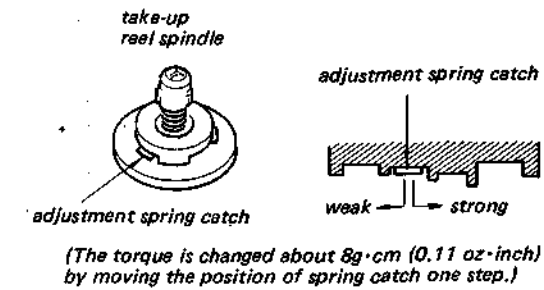

[Pinch Roller Pressure Measurement]
Specification: 310-390g
(11-13.8 oz)

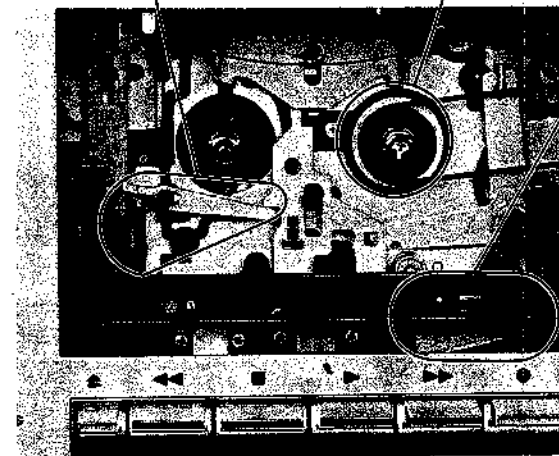

[Hold Switch (S601) Position Adjustment]

— Stop Mode —
Adjust the switch position for specified clearance.

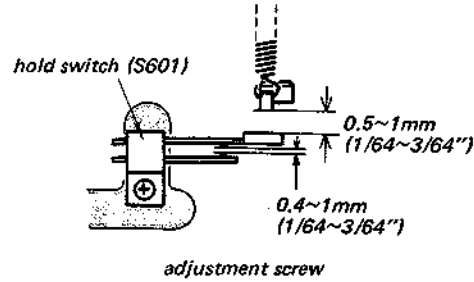

[Motor Switch (S602) Position Adjustment]

— Stop Mode —
Adjust the switch angle for specified distance.

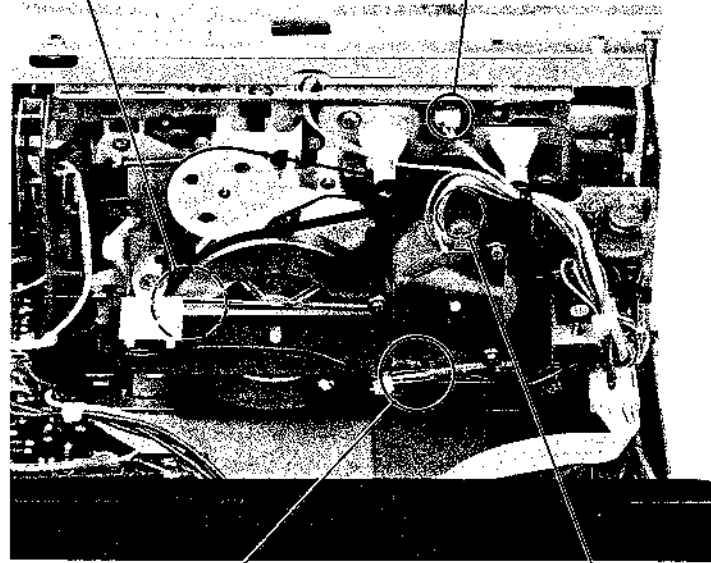
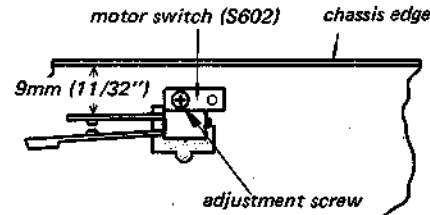

[Muting Switch (S603) Position Adjustment]

— Stop Mode —
Adjust the switch angle for specified clearance.

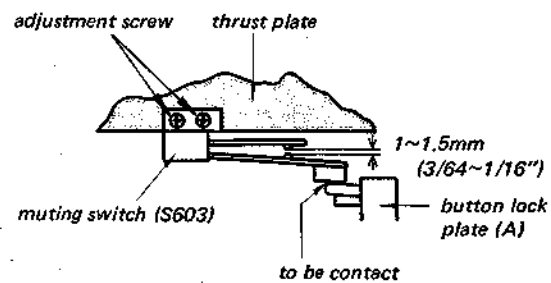

[Motor Pulley Height Adjustment]

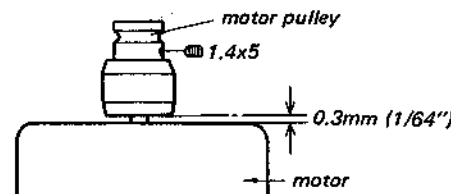

3-2. ELECTRICAL ADJUSTMENTS

Note: The adjustment should be performed in the order given in this service manual. The adjustments should be performed for both L-CH and R-CH.

Test Equipment/Tools Required:

- audio oscillator (af osc)
- VTVM
- digital frequency counter
- speed checker SONY LFM-30
- oscilloscope
- attenuator (600 Ω)
- non-magnetic screwdriver
- resistors 600 Ω (¼ W), 10 kΩ (¼ W), 100 kΩ (¼ W)
- blank tapes (completely erased with bulk eraser)
- SONY CS-10 (HF), CS-20 (CrO₂), CS-30 (Fe-Cr)

- BIAS and EQ switch settings in accordance with tape used are as follows.

Tape	BIAS switch	EQ switch
CS-10	NORMAL	NORMAL
CS-20	HIGH	CrO ₂
CS-30	NORMAL	Fe-Cr

- SONY test tapes
 - P-4-A81S (6.3 kHz, -10 dB)
 - P-4-A81 (6.3 kHz, -10 dB)
 - P-4-L81 (333 Hz, 0 dB)
 - WS-48 (3 kHz, 0 dB)
- Switches and controls should be set as follows unless otherwise specified.
 - DOLBY NR switch: OFF
 - EQ switch: NORMAL
 - BIAS switch: NORMAL

- Standard Record:

Deliver the standard input signal to the input jack and set the REC LEVEL control (RV103, 203) to obtain the standard output signal level.

Standard Input Level

	MIC	LINE IN
source impedance	300Ω	10 kΩ
input level	0.77 mV (-60 dB)	0.25 V (-10 dB)

Standard Output Level

	LINE OUT	HEADPHONES
load impedance	100 kΩ	8 Ω
output level	0.44 V (-5 dB)	39 mV (-26 dB)

Tape Speed Adjustment

Procedure:

Mode: Playback

test tape WS-48 (3 kHz, 0 dB)

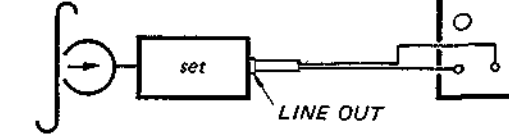

Adjust RV602 to obtain the specified values below.

Specification:

Speed checker	Digital frequency counter
-0.7~+0.7%	2,980~3,020 Hz

Frequency difference between beginning and end of tape should be within 0.7% (20 Hz).

Adjustment Location:

— servo control board —

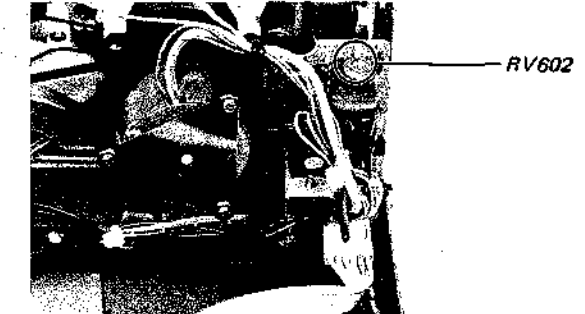

If necessary, adjust by bridging the patterns as follows and adjust RV602 again.

Pattern connection	Tape speed
①	fast
②	slow

Adjustment Location:

— servo control board (conductor side) —

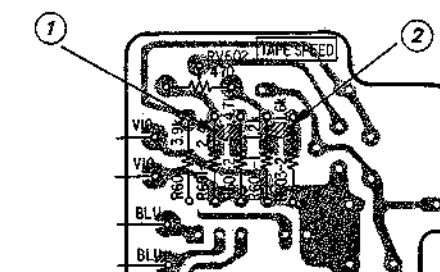

Record/playback Head Azimuth Adjustment

Procedure:

1. Mode: Playback

test tape
P-4-A81S
(6.3 kHz, -10 dB)

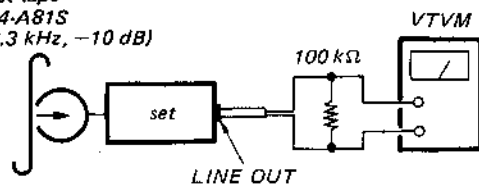

2. Turn the adjustment screw for the maximum level and set it to the mechanical mid position between L-CH and R-CH peak positions.

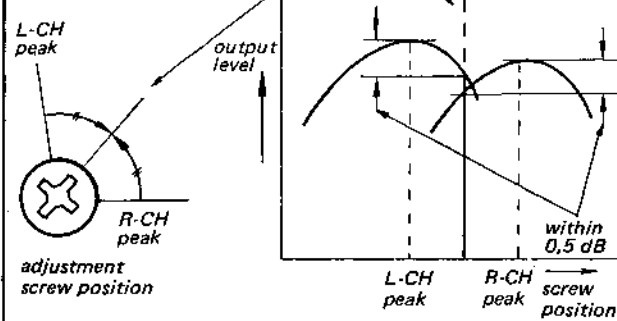

3. Mode: Playback

test tape
P-4-A81S
(6.3 kHz, -10 dB)

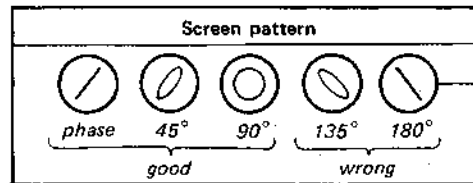
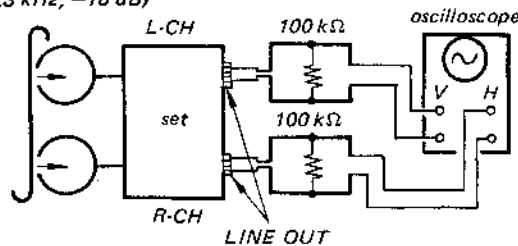

Adjustment Location:

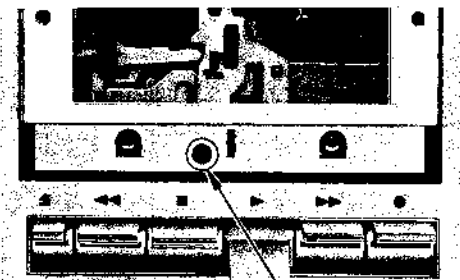

azimuth adjustment screw

Playback Level Adjustment

Procedure:

1. Mode: Playback

test tape
P-4-L81
(333 Hz, 0 dB)

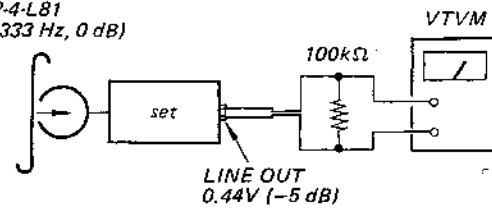

Adjust RV101 (L-CH) and RV201 (R-CH) to obtain the specified VTVM reading.

2. Confirm that the LINE OUT level does not change when the mode is changed from playback to stop several times.

Specification:

LINE OUT level: 0.52-0.59V
(-3.5 to -2.5 dB)

Adjustment Location:

- record/playback amp board -

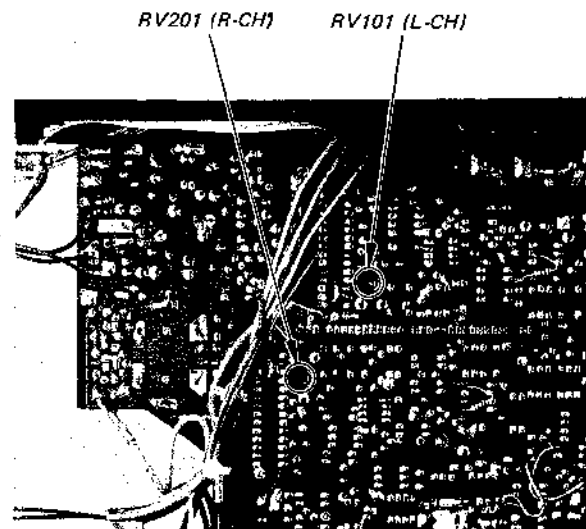

Playback Equalizer Adjustment

Procedure:

- Mode: Playback

test tape
P-4-AB1
(6.3 kHz, -10 dB)

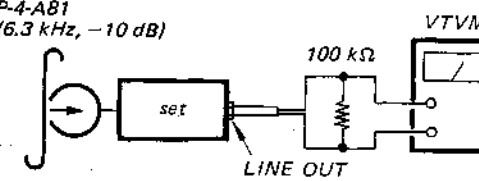

Adjust pattern connections for 0.17-0.18V (-13.2 to -12.8 dB) VTVM reading.

Adjustment Location:

- record/playback amp board -

Pattern connection	VTVM reading
(A), (B)	up
(A)	↓
open	down

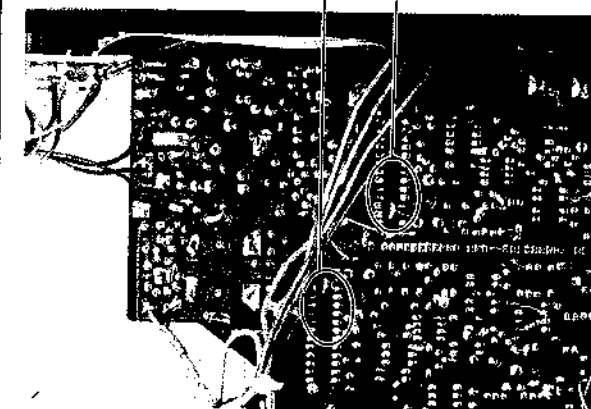
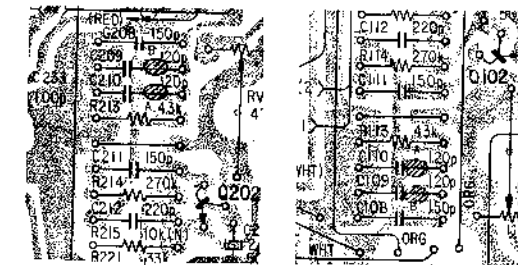

Level Meter Calibration

Procedure:

1. Mode: Standard record (See page 8.)

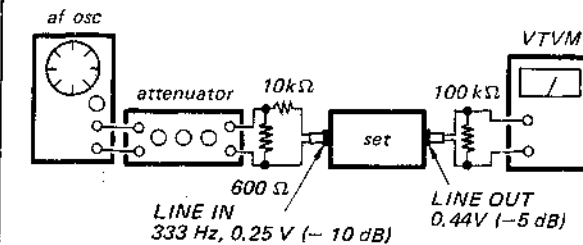

Adjust the pattern connection for 0VU reading on the level meter.

Adjustment Location:

- record/playback amp board -

Pattern connection	Level meter reading
no connection	down
R154 (R254)	↑
R155 (R255)	↑
R154, 155 (R254, 255)	up

() : R-CH

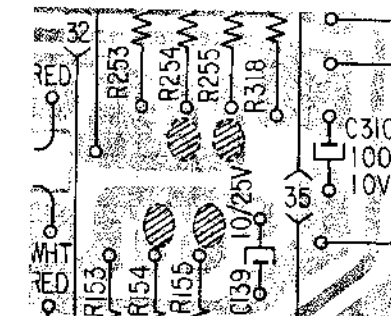
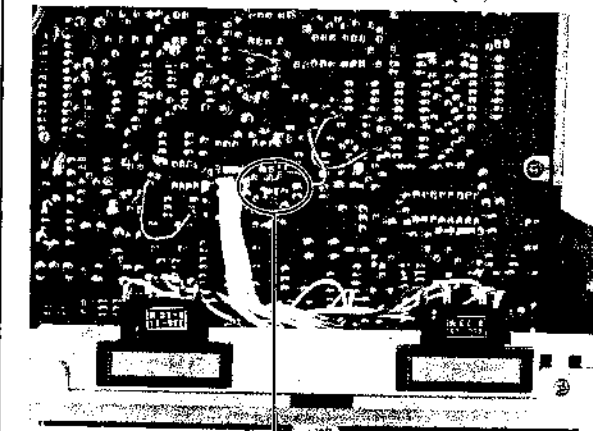

Playback Equalizer Adjustment

Procedure:

Mode: Playback

test tape
P-4-A81
(6.3 kHz, -10 dB)

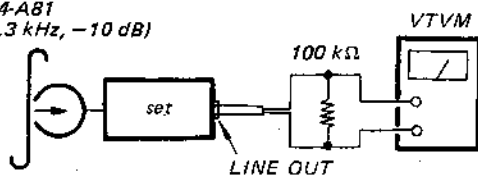

Adjust pattern connections for 0.17-0.18V (-13.2 to -12.8 dB) VTVM reading.

Adjustment Location:

- record/playback amp board -

Pattern connection	VTVM reading
(A), (B)	up
(A)	↓
open	down

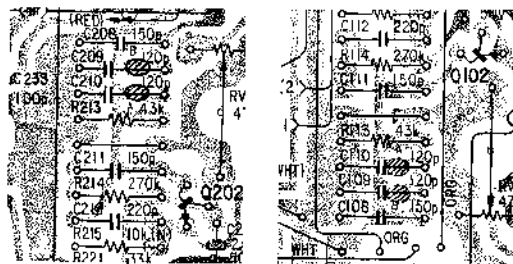

R-CH L-CH

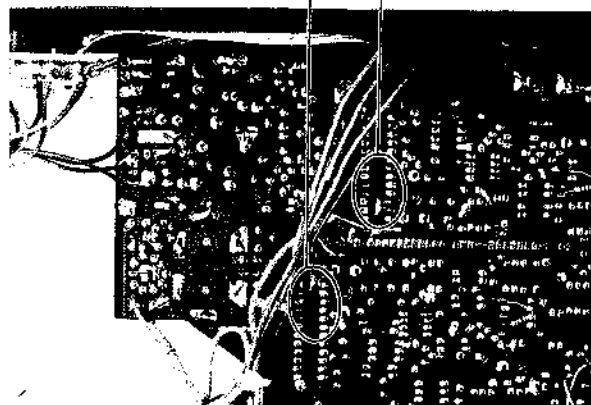

Level Meter Calibration

Procedure:

1. Mode: Standard record (See page 8.)

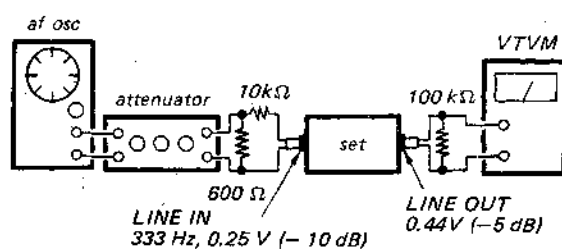

Adjust the pattern connection for 0VU reading on the level meter.

Adjustment Location:

- record/playback amp board -

Pattern connection	Level meter reading
no connection	down
R154 (R254)	↑
R155 (R255)	↑
R154, 155 (R254, 255)	up

() : R-CH

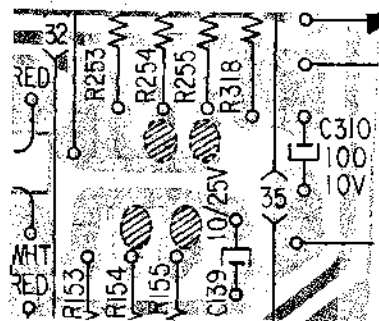
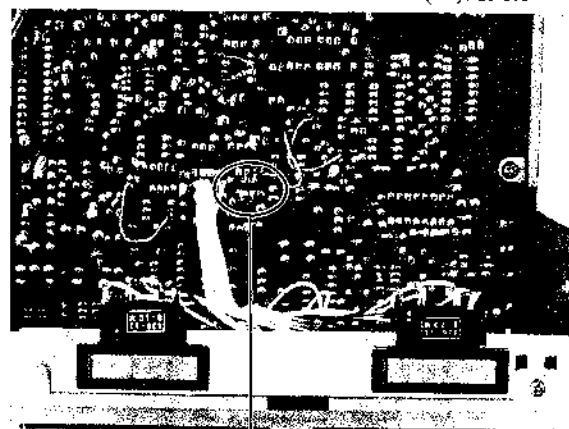

Record Bias Adjustment

Procedure:

1. Mode: Record

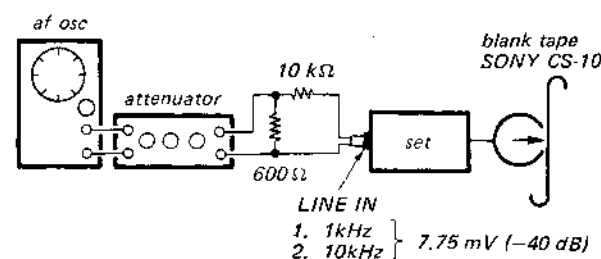

2. Mode: Playback

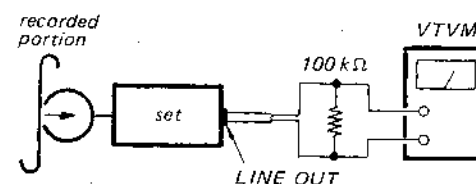

Adjust CT101 (L-CH) and CT201 (R-CH) to make 1kHz and 10kHz signal output levels equal.

Note: If necessary, solder the pattern at or at

Pattern Connection	10kHz VTVM reading
(A)	up
(B)	down

Adjustment Location:

- record/playback amp board -

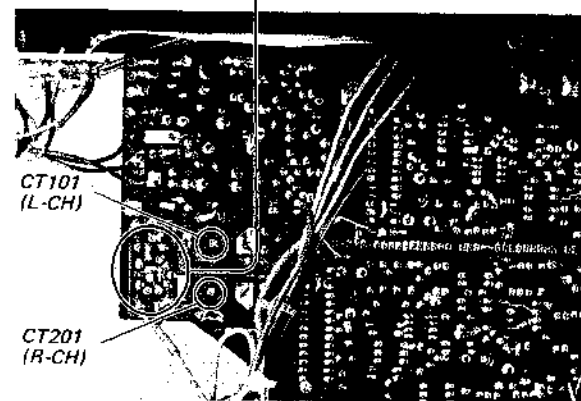
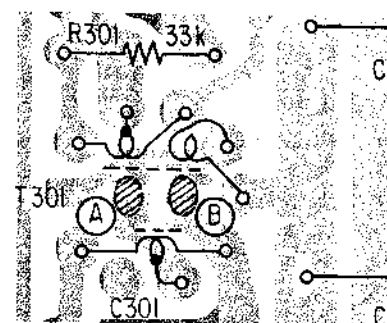

Record Level Adjustment

Procedure:

1. Mode: Standard record (See page 8.)

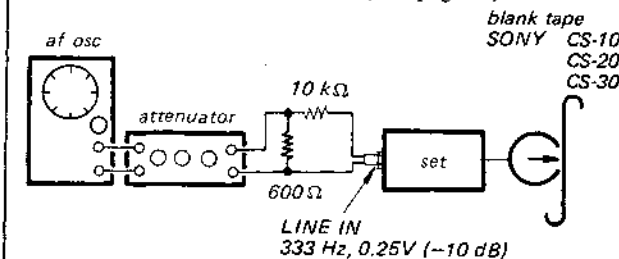

2. Mode: Playback

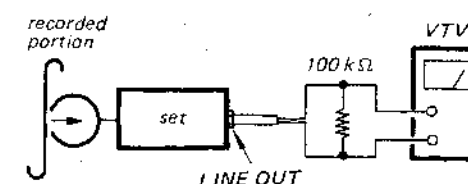

Adjust RV102 (L-CH) and RV202 (R-CH) to obtain the specified VTVM reading.

Specification:

LINE OUT level:

blank tape	LINE OUT LEVEL
CS-10	0.41~0.46 V (-5.5~-4.5 dB)
CS-20	0.31~0.44 V (-8~-5 dB)
CS-30	0.39~0.49 V (-6~-4 dB)

Adjustment Location:

- record/playback amp board -

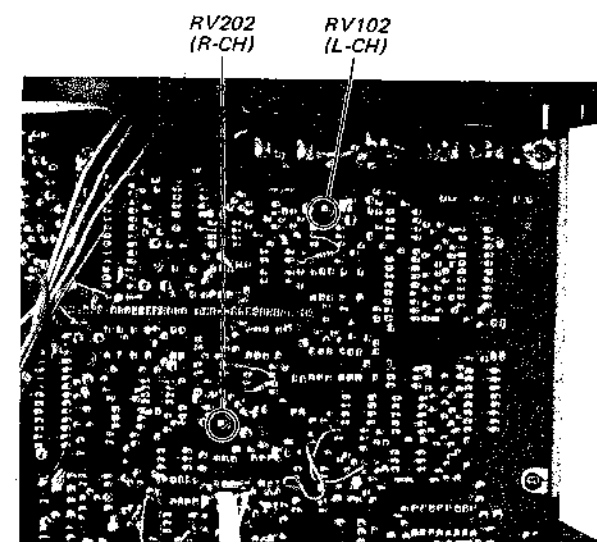

4-1. MOUNTING DIAGRAMS

- Conductor Side -

Replacement semiconductors
(See page 18.)

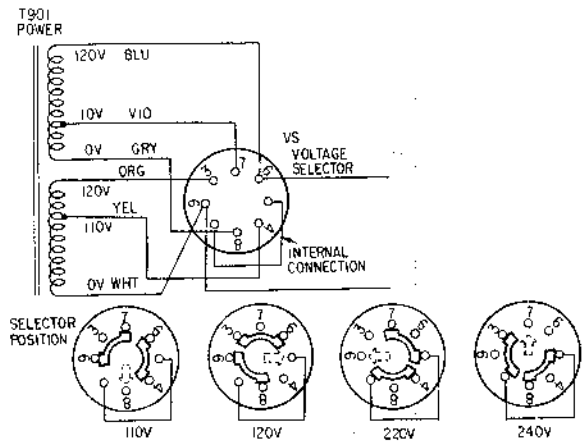
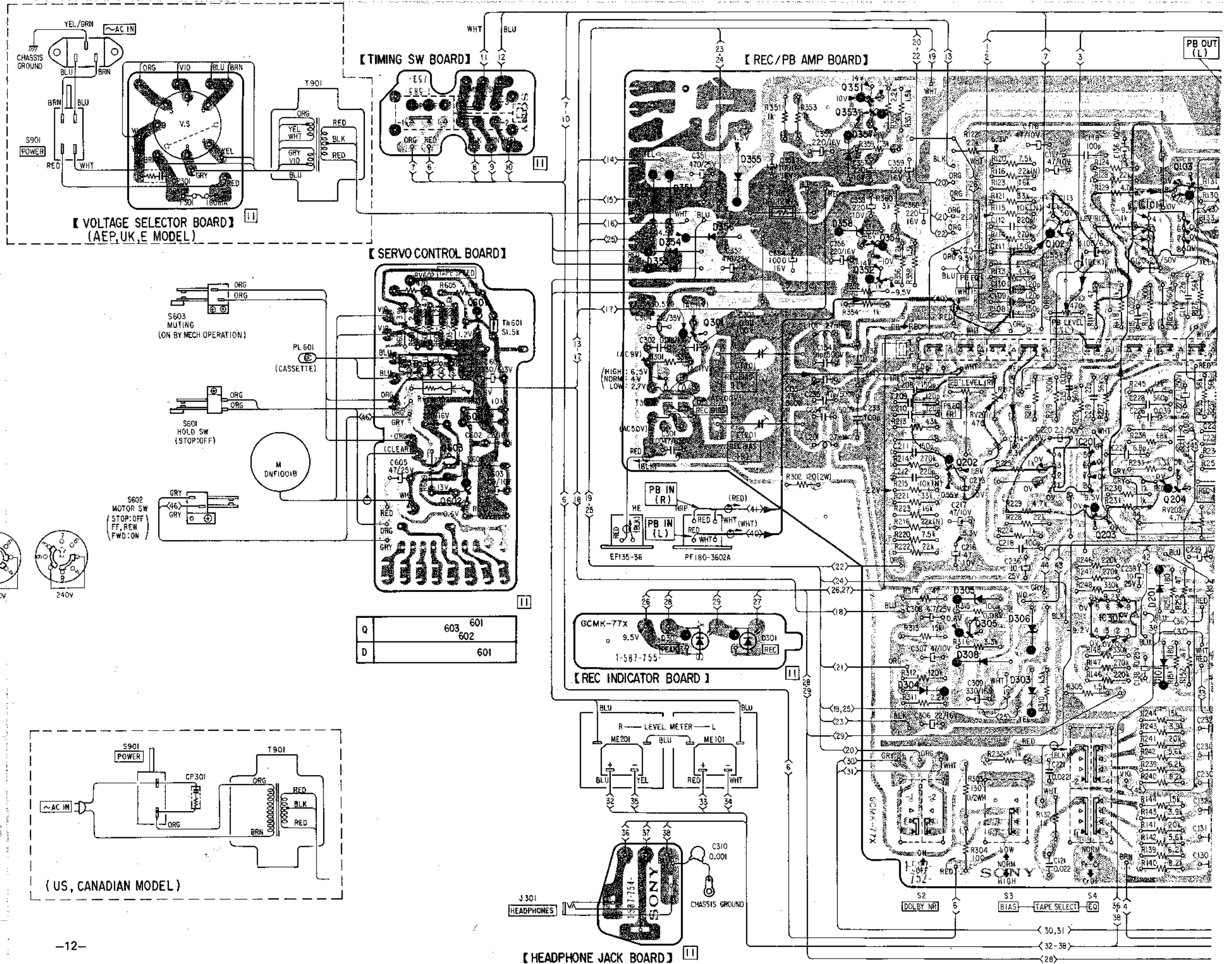

Note:

- B+ pattern
- B- pattern
- Signal Path
 - L-CH
 - R-CH
- Color code of sleeving over the end of the jacket.

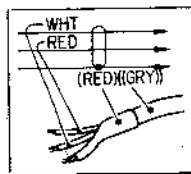

(US, CANADIAN MODEL)

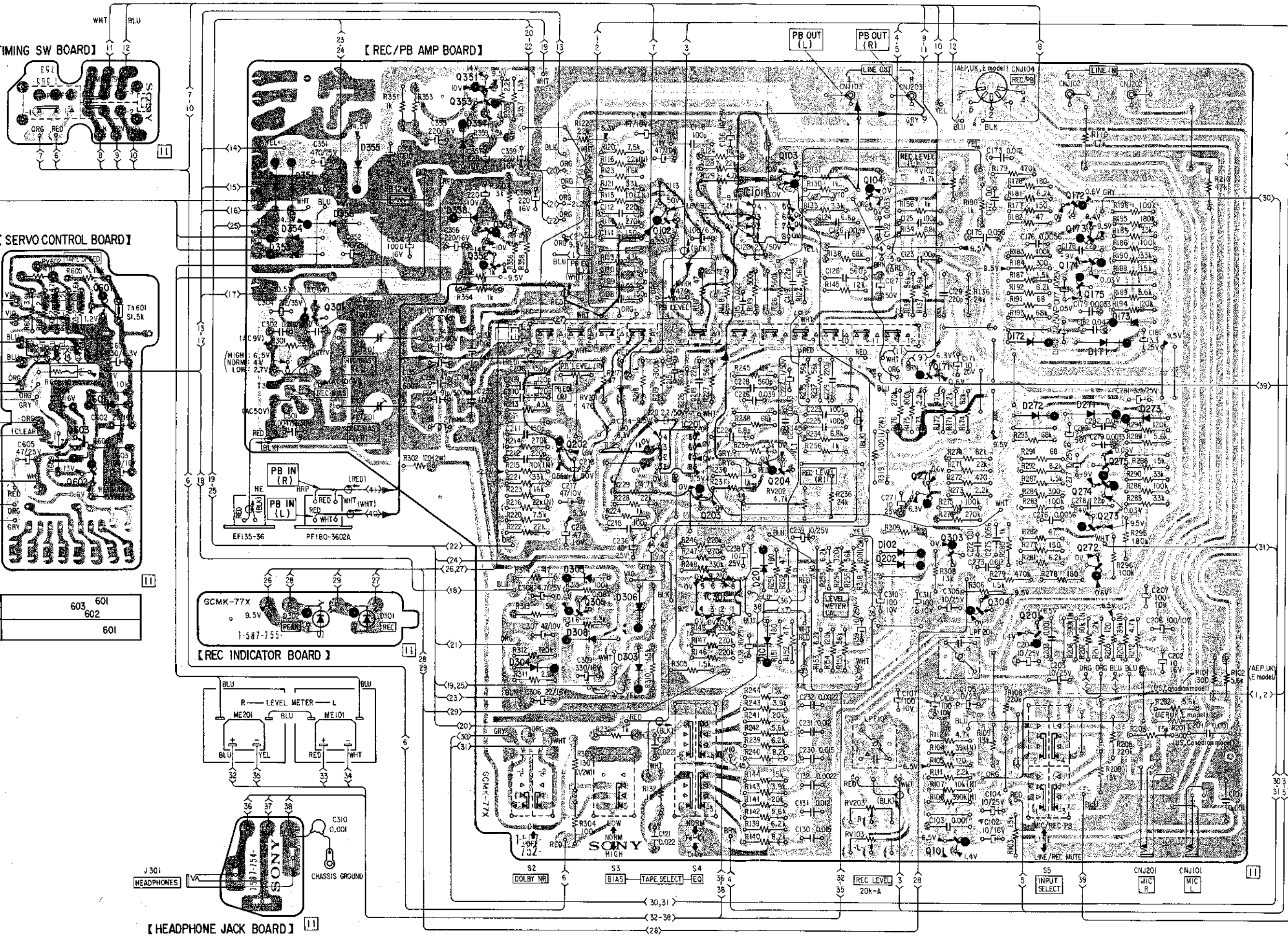

Q, IC	D
351	
353	
	357
103	355
104	352
	351
102	358
354	356
173	354
352	353
	174
	175
301	173
	172
	171
	171
	272
	271
	273
202	IC201
275	
204	274
271	
203	
	273
303	102
272	202
201	305
IC301	
305	306
201	308
	101
	304
	303
101	
Q, IC	D

4-2. SCHEMATIC DIAGRAM

[REC/PB AMP BOARD]

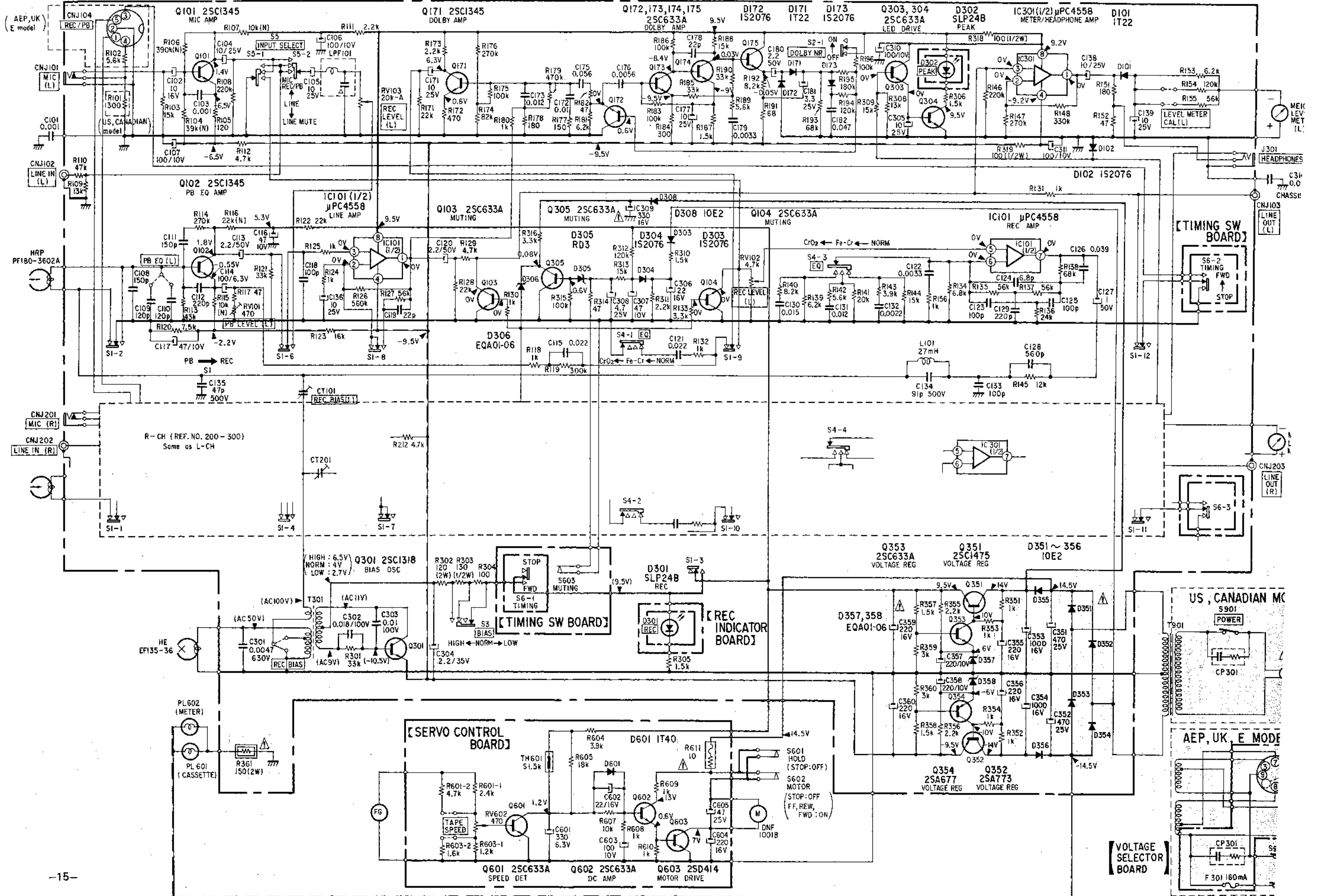

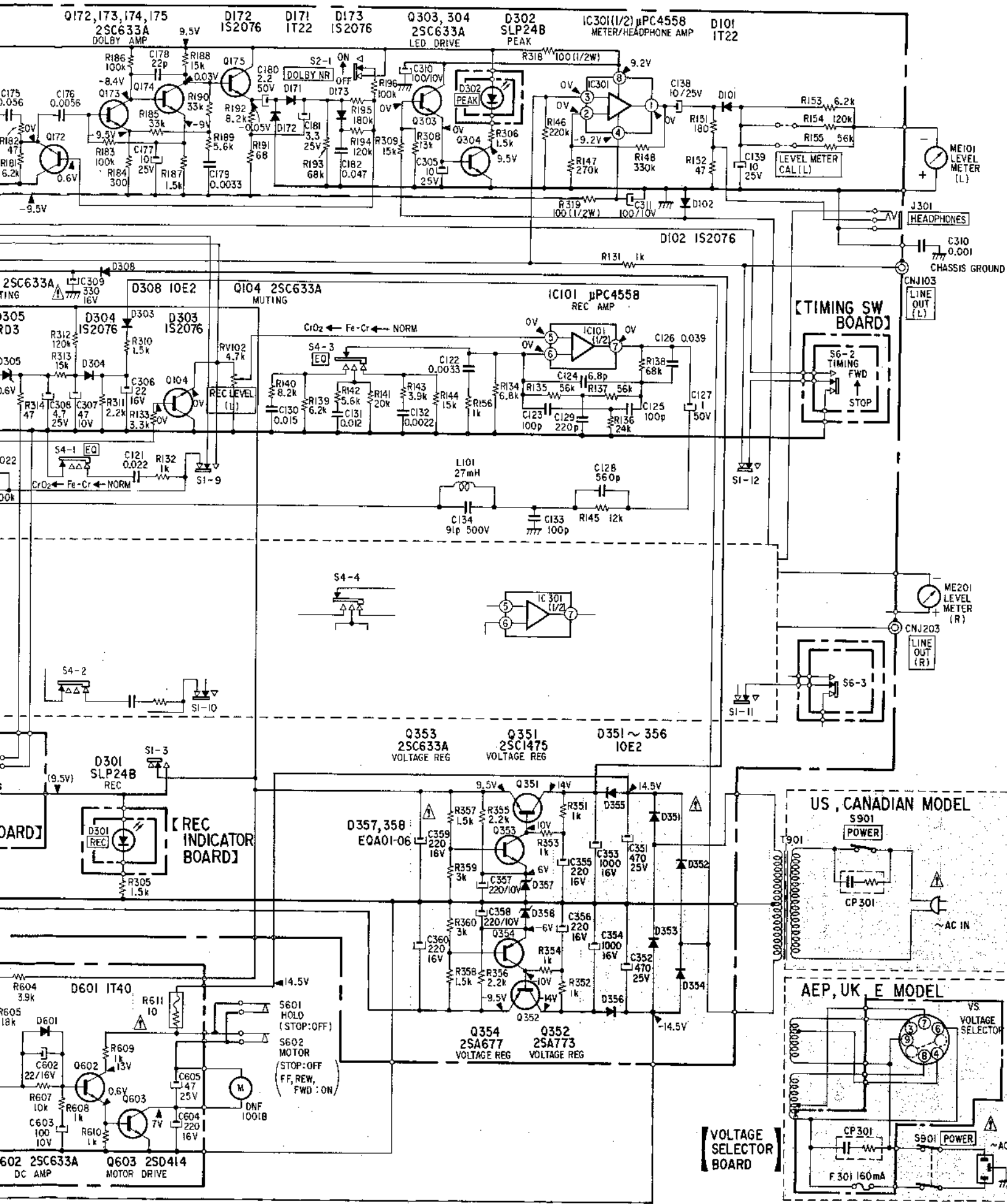

- Note:**
- All capacitors are in μF unless otherwise noted. $\text{pF} : \mu\text{F}$ 50 WV or less are not indicated except for electrolytics.
 - All resistors are in ohms, $\frac{1}{4}\text{W}$ unless otherwise noted. $\text{k}\Omega : 1000\Omega$; $\text{M}\Omega : 1000\text{k}\Omega$
 - All variable and adjustable resistors have characteristic curve B, unless otherwise noted.
 - \square : nonflammable resistor. (N): low noise resistor
 - --- : fusible resistor.
 - --- : B+ bus.
 - --- : B- bus.
 - \square : panel designation.
 - \square : adjustment for repair.
 - Voltages are dc with respect to ground unless otherwise noted.
 - Readings are taken in playback mode with a VOM (20 $\text{k}\Omega/\text{V}$). () : record mode
 - Switch

SECTION 5
EXPLODED VIEWS

Note: Circled letters (A to Z) are applicable to European models only.

Replacement semiconductors

For replacement, use semiconductors except in (),

Q101, 102
Q201, 202
Q171, 271

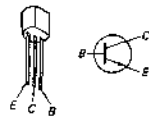

2SC1345

Q103, 104
Q203, 204
Q172-175
Q272-275
Q303-305
Q353, 601,
Q602

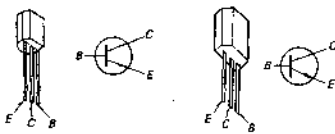

2SC1364

(2SC633A)

Q301
Q351

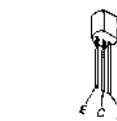

2SC1475

(2SC1318)

Q352

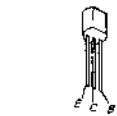

2SA684

(2SA773)

Q354

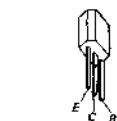

2SA678

(2SA677)

Q603 2SD414

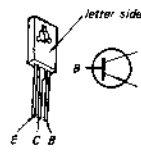

IC101, 201, 301 μ PC4558

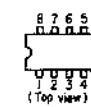

D101, 201
D171, 271

1T22AM (1T22)

D102, 202
D172, 272
D173, 273
D303, 304

1S1555 (1S2076)

D601 1S1555 (1T40)
D305 RD3A (RD3)

D308, 351-356 10E2

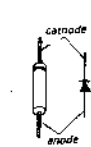

D306, 357, 358 EQB01-06 (EQA01-06)

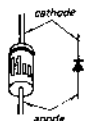

D301, 302 SLP24B

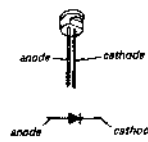

5-1.

A B C D E

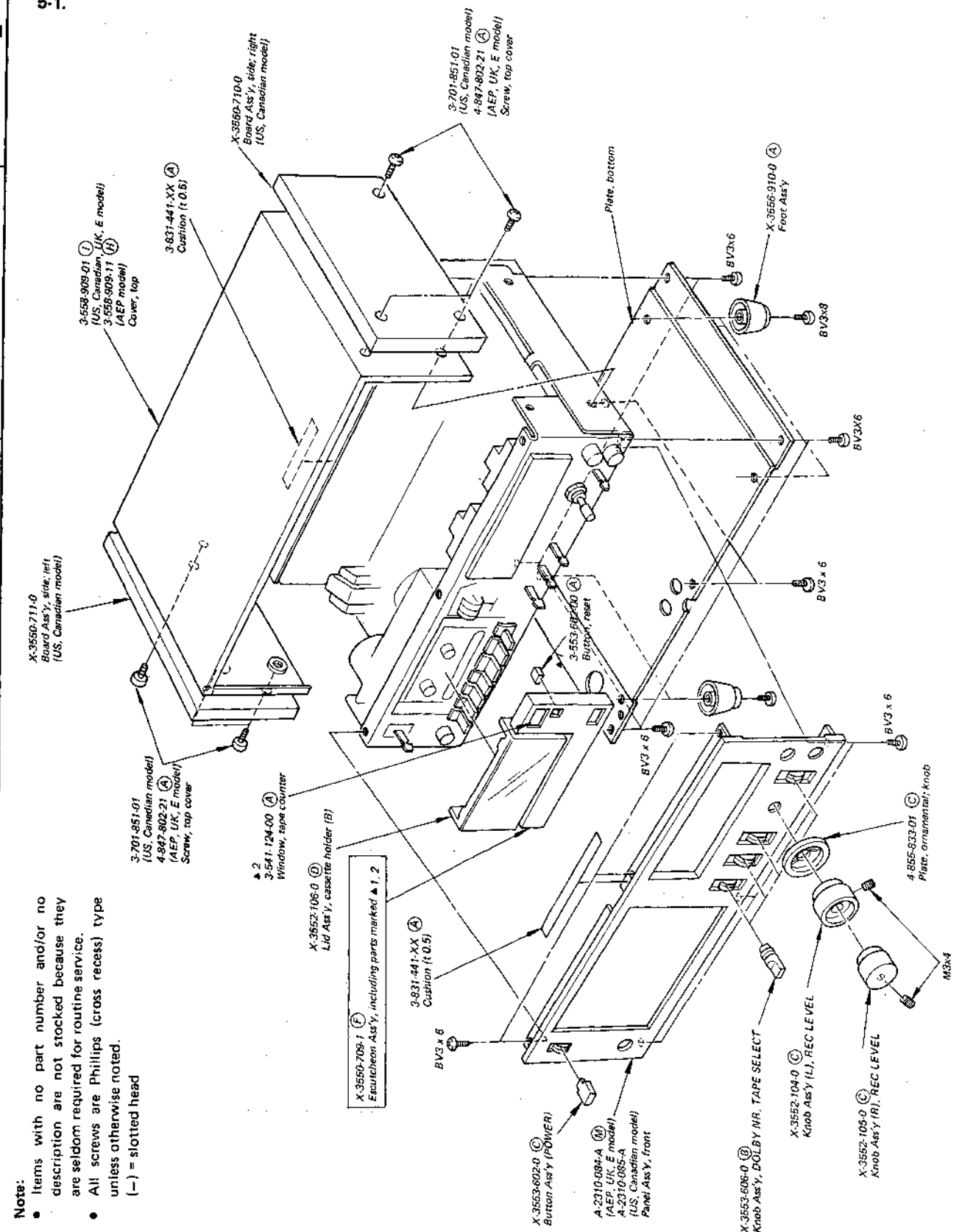

Note:
 • Items with no part number and/or no description are not stocked because they are seldom required for routine service.
 • All screws are Phillips (cross recess) type unless otherwise noted.
 (-) = slotted head

5-2. A B C D E

Note: Circled letters (A) to (Z) are applicable to European models only.

A B C D E

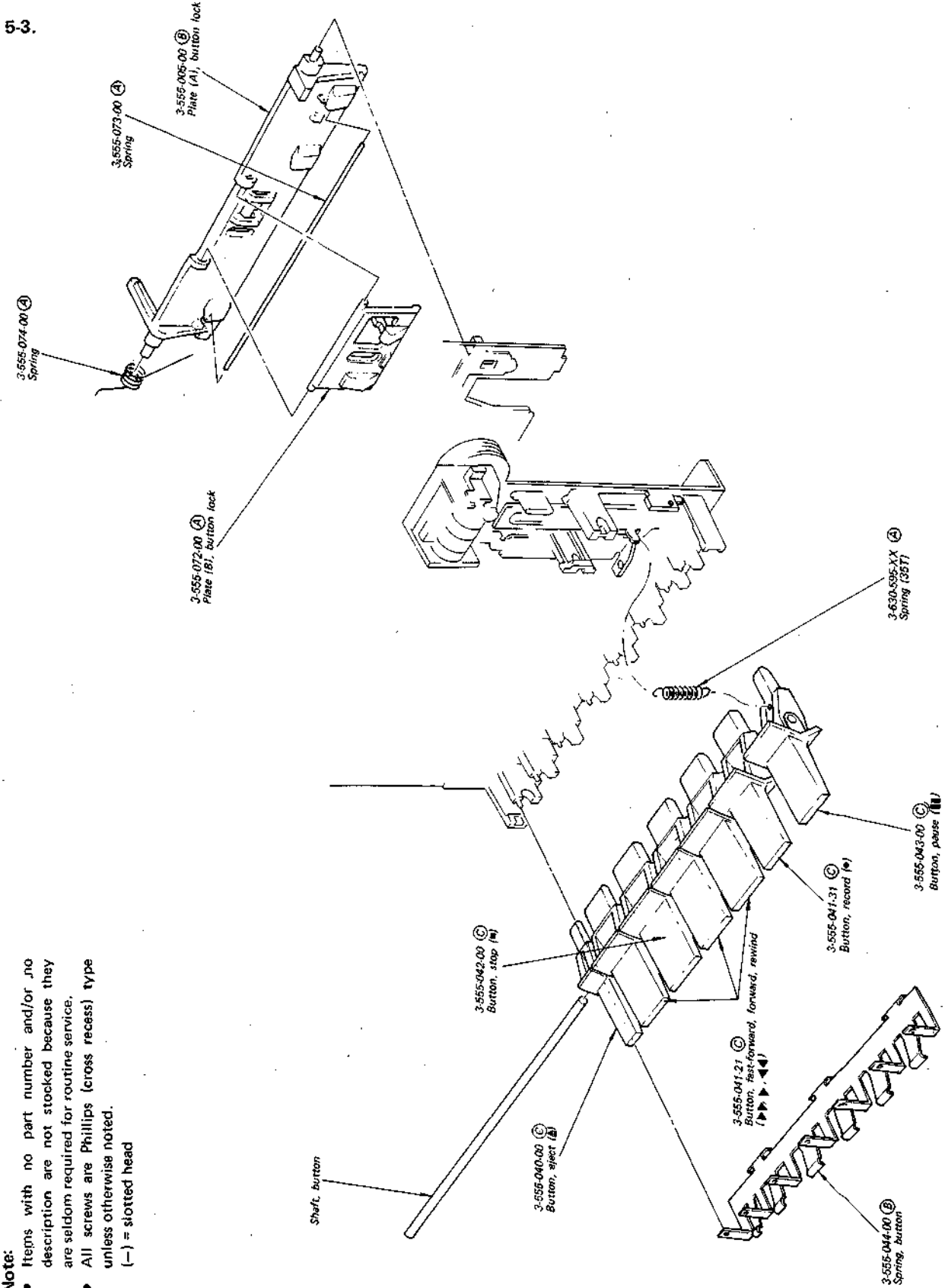

Note:

- Items with no part number and/or no description are not stocked because they are seldom required for routine service.
- All screws are Phillips (cross recess) type unless otherwise noted.
- (-) = slotted head

1 2 3 4

Note: Circled letters (A to Z) are applicable to European models only.

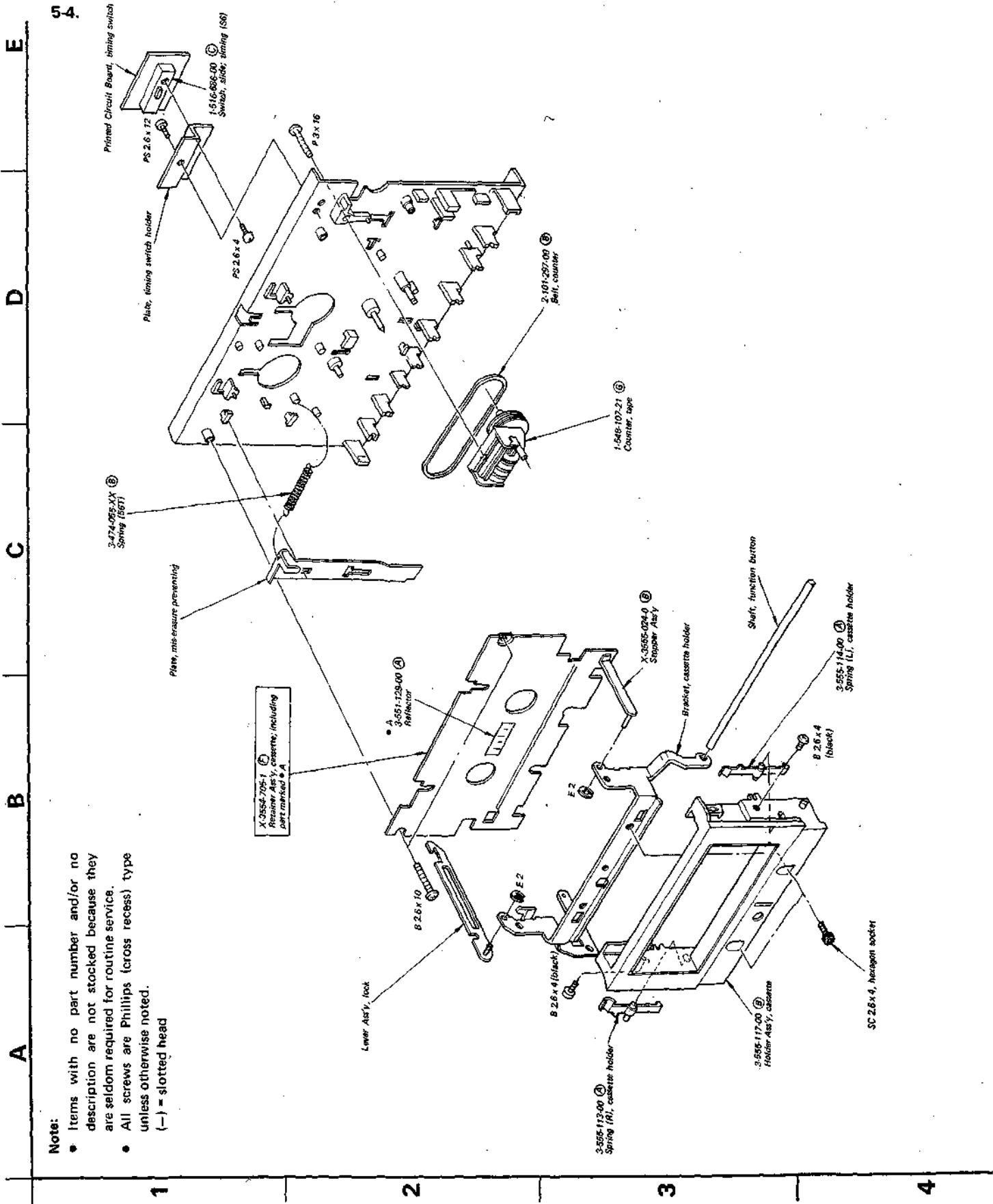

Notes:

- Items with no part number and/or no description are not stocked because they are seldom required for routine service.
- All screws are Phillips (cross recess) type unless otherwise noted.
- (-) = slotted head

SECTION 6 ELECTRICAL PARTS LIST

Note: Circled letters (A) to (Z) are applicable to European models only.

Ref. No.	Part No.	Description
SEMICONDUCTORS		
Transistors		
Q ^{101,201} 102,202	8-729-334-58 (B)	2SC1345
⇒ Q ^{103,203} 104,204	8-729-663-47 (B)	2SC1364
Q171,271	8-729-334-58 (B)	2SC1345
⇒ Q ^{172~175} 272~275	8-729-663-47 (B)	2SC1364
⇒ Q301	8-760-413-10 (B)	2SC1475
⇒ Q303-305	8-729-663-47 (B)	2SC1364
Q351	8-760-413-10 (B)	2SC1475
⇒ Q352	8-829-468-43 (B)	2SA684
⇒ Q353	8-729-663-47 (B)	2SC1364
⇒ Q354	8-727-786-01 (B)	2SA678
⇒ Q601,602	8-729-663-47 (B)	2SC1364
Q603	8-729-141-43 (B)	2SD414
ICs		
IC ^{101,201} 301	8-759-145-58 (D)	μPC4558
Diodes		
⇒ D101,201	8-719-422-21 (A)	1T22AM
⇒ D102,202	8-719-815-55 (A)	1S1555
⇒ D171,271	8-719-422-21 (A)	1T22AM
⇒ D ^{172,272} 173,273	8-719-815-55 (A)	1S1555
D301,302	8-719-900-24 (B)	SLP24B
⇒ D303,304	8-719-815-55 (A)	1S1555
⇒ D305	8-719-133-00 (B)	RD3A
⇒ D306	8-719-931-06 (B)	EQB01-06
D308	8-719-200-02 (B)	10E2
D351~354	8-719-200-02 (B)	10E2
D355, 356	8-719-200-02 (B)	10E2
⇒ D357,358	8-719-931-06 (B)	EQB01-06
⇒ D601	8-719-815-55 (A)	1S1555
Thermistor		
Th601	1-800-200-11 (B)	S-1.5k

⇒ : Due to standardization, interchangeable replacements may be substituted for parts specified in the diagrams.

Note: The components identified by shading and mark **A** are critical for safety. Replace only with part number specified.

Ref. No.	Part No.	Description
COIL		
L101,201	1-407-211-XX (B)	27mH, microinductor
TRANSFORMERS		
T301	1-433-132-00 (C)	Bias Oscillator
T901	1-446-150-00 (A)	Power (US, Canadian model)
T901	1-446-151-00 (L)	Power (AEP, UK, E model)
CAPACITORS		
All capacitors are in μF and ceramic unless otherwise noted. 50WV or less are not indicated except for electrolytic and tantalum. pF: μμF, elect: electrolytic		
C101,201	1-161-323-11 (A)	0.001
C102,202	1-121-916-11 (A)	10 16V elect
C103,203	1-161-323-11 (A)	0.001
C ^{104,204} 105,205	1-121-398-11 (A)	10 25V elect
C ^{106,206} 107,207	1-121-414-11 (A)	100 10V elect
C108,208	1-161-313-11 (A)	150p
C ^{109,209} 110,210	1-161-272-11 (A)	120p
C111,211	1-161-313-11 (A)	150p
C112,212	1-161-315-11 (A)	220p
C113,213	1-123-050-11 (A)	2.2 50V elect
C114,214	1-121-413-11 (A)	100 6.3V elect
C115,215	1-108-587-12 (A)	0.022 mylar
C ^{116,216} 117,217	1-121-352-11 (A)	47 10V elect
C118,218	1-161-271-11 (A)	100p
C119,219	1-161-263-11 (A)	22p
C120,220	1-121-450-11 (A)	2.2 50V elect
C121,221	1-108-587-12 (A)	0.022 mylar
C122,222	1-161-327-11 (A)	0.0033
C123,223	1-161-271-11 (A)	100p
C124,224	1-161-257-11 (A)	6.8p
C125,225	1-161-271-11 (A)	100p
C126,226	1-108-593-12 (A)	0.039 mylar
C127,227	1-121-391-11 (A)	1 50V elect
C128,228	1-161-320-11 (A)	560p

Note: Les composants identifiés par un trame et une marque **A** sont critiques pour la sécurité. Ne les remplacer que par une pièce portant le numéro spécifié.

Note: Circled letters (A) to (Z) are applicable to European models only.

Ref. No.	Part No.	Description
C129,229	1-161-315-11 (A)	220p
C130,230	1-108-583-12 (A)	0.015 mylar
C131,231	1-108-581-12 (A)	0.012 mylar
C132,232	1-108-563-12 (A)	0.0022 mylar
C133,233	1-161-271-11 (A)	100p
C134,234	1-107-168-11 (A)	91p 500V silvered mica
C135,235	1-107-163-11 (A)	47p 500V silvered mica
C136,236	1-121-398-11 (A)	10 25V elect
C138,238 C139,239	1-121-398-11 (A)	10 25V elect
C171,271	1-121-398-11 (A)	10 25V elect
C172,272	1-108-579-12 (A)	0.01 mylar
C173,273	1-108-581-12 (A)	0.012 mylar
C175,275	1-108-597-12 (A)	0.056 mylar
C176,276	1-108-573-12 (A)	0.0056 mylar
C177,277	1-121-398-11 (A)	10 25V elect
C178,278	1-161-263-11 (A)	22p
C179,279	1-108-567-12 (A)	0.0033 mylar
C180,280	1-121-986-11 (A)	2.2 50V elect
C181,281	1-121-960-11 (A)	3.3 25V elect
C182,282	1-108-595-12 (A)	0.047 mylar
C301	1-129-710-11 (A)	0.0047 630V polyethylene
C302	1-106-202-12 (A)	0.018 100V mylar
C303	1-129-701-11 (B)	0.01 100V polyethylene
C304	1-121-450-11 (A)	2.2 50V elect
C305	1-121-398-11 (A)	10 25V elect
C306	1-121-479-11 (A)	22 16V elect
C307	1-121-352-11 (A)	47 10V elect
C308	1-121-395-11 (A)	4.7 25V elect
C309	1-121-521-11 (B)	330 16V elect
C310	1-161-323-11 (A)	0.001
C311	1-121-414-11 (A)	100 10V elect
C351,352	1-123-336-11 (B)	470 25V elect
C353,354	1-123-324-11 (B)	1000 16V elect
C355,356	1-123-321-11 (A)	220 16V elect
C357,358	1-123-308-11 (A)	220 10V elect
C359,360	1-123-321-11 (A)	220 16V elect
CT101,201	1-141-010-XX (B)	120p Trimmer

Ref. No.	Part No.	Description
RESISTORS		
All resistors are in ohms. Common 1/4W carbon resistors are omitted. Refer to the list on page 29 for their part numbers (kΩ: 1000Ω, MΩ: 1000kΩ)		
R302	1-217-225-11 (B)	120 2W wirewound
R303	1-244-852-11 (A)	130 1/2W
R318,319	1-244-849-11 (A)	100 1/2W
R361	1-206-644-11 (A)	150 2W metal oxide (nonflammable)
R611	1-217-387-11 (B)	10 1/4W fusible
RV101,201	1-224-641-XX (B)	470-B, adjustable; PB LEVEL
RV102,202	1-224-644-XX (B)	4.7k-B, adjustable; REC LEVEL
RV103,203	1-226-207-00 (E)	20k-A, variable; REC LEVEL
RV602	1-224-630-00 (B)	470-B, adjustable; TAPE SPEED
SWITCHES		
S1	1-516-263-00 (C)	Slide, REC/PB
S2	1-552-367-00 (C)	Lever-slide, DOLBY NR
S3	1-552-368-00 (C)	Lever-slide, BIAS
S4	1-552-366-00 (C)	Lever-slide, EQ
S5	1-552-543-00 (C)	Lever-slide, INPUT SELECT
S6	1-516-686-00 (C)	Slide, TIMING
S601,602	1-514-912-00 (B)	Leaf, HOLD, MOTOR
S603	1-516-853-XX (C)	Leaf, MUTING
S901	1-552-018-00 (A)	Pushbutton, POWER (US, Canadian model)
S901	1-552-206-11 (C)	Pushbutton, POWER (AEP, UK, E model)
JACKS		
J301	1-507-439-00 (B)	Phone, HEADPHONES
CNJ101,201	1-507-525-00 (C)	Phone, MIC
CNJ102,202	1-507-531-21	Phono, LINE IN, OUT (US, Canadian model)
CNJ103,203		
CNJ102,202	1-536-501-21 (C)	Phono, LINE IN/OUT (AEP, UK, E model)
CNJ103,203		
CNJ104		Connector, REC/PB
VS	1-552-026-00 (D)	Voltage Selector (AEP, UK, E model)
MISCELLANEOUS		
CP301	1-231-057-31 (B)	Spark Killer (AEP, UK, E model)
CP301	1-231-326-11	Spark Killer (US model)
CP301	1-231-341-00	Spark Killer (Canadian model)

Note: The components identified by shading and mark **A** are critical for safety. Replace only with part number specified.

Note: Les composants identifiés par un trame et une marque **A** sont critiques pour la sécurité. Ne les remplacer que par une pièce portant le numéro spécifié.

Note: Circled letters (A to Z) are applicable to European models only.

<u>Ref. No.</u>	<u>Part No.</u>	<u>Description</u>
F301	▲ 1-532-079-00 (B)	Fuse 160mA (AEP, UK, E model)
LPF101,201	1-231-372-00 (C)	Filter, lowpass
HE	8-825-506-00 (C)	Head, erase; EF135-36
HRP	8-825-710-00 (L)	Head, rec/pb; PF180-3602A
M	8-835-006-00 (L)	Motor DNF-1001B
ME101,201	1-520-336-00 (J)	Meter, level
PL601	1-518-115-XX (B)	Lamp, 8V/50mA cassette
PL602	1-518-340-71 (B)	Lamp, 8V/300mA meter
	▲ 1-509-546-00 (D)	AC Input Connector (AEP, E, UK model)
	▲ 1-534-986-XX	Cord, power (US, Canadian model)
	1-548-107-21 (G)	Counter, tape

ACCESSORIES & PACKING MATERIALS

<u>Part No.</u>	<u>Description</u>
X-3701-029-6	Card Ass'y, warranty (US model)
X-3701-105-0 (A)	Head Cleaning Tip Ass'y
1-534-049-31 (E)	Cord, connection RK-74H
▲ 1-534-754-00	Cord, power, parallel-blade plug (E model)
▲ 1-534-819-00 (G)	Cord, power (UK model)
▲ 1-551-216-00	Cord, power, euro-plug (E model)
3-550-768-00 (D)	Carton
3-552-147-00 (B)	Cushion (A)
3-552-148-00 (B)	Cushion (B)
3-701-630-00 (A)	Bag, plastic
3-701-684-11 (A)	Card, line voltage (AEP, UK, E model)
3-701-730-00	Bag, plastic, IBM card (US model)
3-770-564-11 (G)	Manual, instruction (AEP, UK, E model)
3-770-564-21	Manual, instruction (US model)
3-770-564-21	Manual, instruction (Canadian model)
3-794-269-31	Card, instruction
3-793-828-11 (A)	Card, caution; tape cassette
3-794-268-11 (B)	Card, instruction (AEP model)
4-891-037-00 (B)	Bag, plastic

Note: The components identified by shading and mark **▲** are critical for safety. Replace only with part number specified.

Note: Les composants identifiés par un trame et une marque **▲** sont critiques pour la sécurité. Ne les remplacer que par une pièce portant le numéro spécifié.

1/4 WATT CARBON RESISTORS (A)

Note: Circled letter (A) is applicable to European models only.

Ω	Part No.	Ω	Part No.	Ω	Part No.	Ω	Part No.	Ω	Part No.	Ω	Part No.	Ω	Part No.
1.0	1-244-601-11	10	1-244-625-11	100	1-244-649-11	1.0k	1-244-673-11	10k	1-244-697-11	100k	1-244-721-11	1.0M	1-244-745-11
1.1	1-244-602-11	11	1-244-626-11	110	1-244-650-11	1.1k	1-244-674-11	11k	1-244-698-11	110k	1-244-722-11	1.1M	1-244-746-11
1.2	1-244-603-11	12	1-244-627-11	120	1-244-651-11	1.2k	1-244-675-11	12k	1-244-699-11	120k	1-244-723-11	1.2M	1-244-747-11
1.3	1-244-604-11	13	1-244-628-11	130	1-244-652-11	1.3k	1-244-676-11	13k	1-244-700-11	130k	1-244-724-11	1.3M	1-244-748-11
1.5	1-244-605-11	15	1-244-629-11	150	1-244-653-11	1.5k	1-244-677-11	15k	1-244-701-11	150k	1-244-725-11	1.5M	1-244-749-11
1.6	1-244-606-11	16	1-244-630-11	160	1-244-654-11	1.6k	1-244-678-11	16k	1-244-702-11	160k	1-244-726-11	1.6M	1-244-750-11
1.8	1-244-607-11	18	1-244-631-11	180	1-244-655-11	1.8k	1-244-679-11	18k	1-244-703-11	180k	1-244-727-11	1.8M	1-244-751-11
2.0	1-244-608-11	20	1-244-632-11	200	1-244-656-11	2.0k	1-244-680-11	20k	1-244-704-11	200k	1-244-728-11	2.0M	1-244-752-11
2.2	1-244-609-11	22	1-244-633-11	220	1-244-657-11	2.2k	1-244-681-11	22k	1-244-705-11	220k	1-244-729-11	2.2M	1-244-753-11
2.4	1-244-610-11	24	1-244-634-11	240	1-244-658-11	2.4k	1-244-682-11	24k	1-244-706-11	240k	1-244-730-11	2.4M	1-244-754-11
2.7	1-244-611-11	27	1-244-635-11	270	1-244-659-11	2.7k	1-244-683-11	27k	1-244-707-11	270k	1-244-731-11	2.7M	1-244-755-11
3.0	1-244-612-11	30	1-244-636-11	300	1-244-660-11	3.0k	1-244-684-11	30k	1-244-708-11	300k	1-244-732-11	3.0M	1-244-756-11
3.3	1-244-613-11	33	1-244-637-11	330	1-244-661-11	3.3k	1-244-685-11	33k	1-244-709-11	330k	1-244-733-11	3.3M	1-244-757-11
3.6	1-244-614-11	36	1-244-638-11	360	1-244-662-11	3.6k	1-244-686-11	36k	1-244-710-11	360k	1-244-734-11	3.6M	1-244-758-11
3.9	1-244-615-11	39	1-244-639-11	390	1-244-663-11	3.9k	1-244-687-11	39k	1-244-711-11	390k	1-244-735-11	3.9M	1-244-759-11
4.3	1-244-616-11	43	1-244-640-11	430	1-244-664-11	4.3k	1-244-688-11	43k	1-244-712-11	430k	1-244-736-11	4.3M	1-244-760-11
4.7	1-244-617-11	47	1-244-641-11	470	1-244-665-11	4.7k	1-244-689-11	47k	1-244-713-11	470k	1-244-737-11	4.7M	1-244-761-11
5.1	1-244-618-11	51	1-244-642-11	510	1-244-666-11	5.1k	1-244-690-11	51k	1-244-714-11	510k	1-244-738-11	5.1M	1-244-762-11
5.6	1-244-619-11	56	1-244-643-11	560	1-244-667-11	5.6k	1-244-691-11	56k	1-244-715-11	560k	1-244-739-11		
6.2	1-244-620-11	62	1-244-644-11	620	1-244-668-11	6.2k	1-244-692-11	62k	1-244-716-11	620k	1-244-740-11		
6.8	1-244-621-11	68	1-244-645-11	680	1-244-669-11	6.8k	1-244-693-11	68k	1-244-717-11	680k	1-244-741-11		
7.5	1-244-622-11	75	1-244-646-11	750	1-244-670-11	7.5k	1-244-694-11	75k	1-244-718-11	750k	1-244-742-11		
8.2	1-244-623-11	82	1-244-647-11	820	1-244-671-11	8.2k	1-244-695-11	82k	1-244-719-11	820k	1-244-743-11		
9.1	1-244-624-11	91	1-244-648-11	910	1-244-672-11	9.1k	1-244-696-11	91k	1-244-720-11	910k	1-244-744-11		

HARDWARE NOMENCLATURE

Screw:

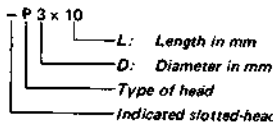

Unless otherwise indicated, it means cross-recessed head (Phillips type).

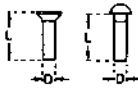

Nut, Washer, Retaining ring:

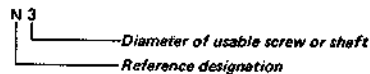

Reference Designation	Shape	Description	Remarks
SCREWS			
P		pan-head screw	binding-head (B) screw for replacement
PWH		pan-head screw with washer face	binding-head (B) screw and flat washer for replacement
PS PSP		pan-head screw with spring washer	binding-head (B) screw and spring washer for replacement
PSW PSPW		pan-head screw with spring and flat washers	binding-head (B) screw and spring and flat washers for replacement
R		round-head screw	binding-head (B) screw for replacement
K		flat-countersunk-head screw	
RK		oval-countersunk-head screw	
B		binding-head screw	
T		truss-head screw	binding-head (B) screw for replacement
F		flat-fillister-head screw	
RF		fillister-head screw	
BV		brazer-head screw	

Reference Designation	Shape	Description	Remarks
SELF-TAPPING SCREWS			
TA		self-tapping screw	ex: TA, P 3 x 10
PTP		pan-head self-tapping screw	binding-head self-tapping (TA, B) screw for replacement
PTPWH		pan-head self-tapping screw with washer face	binding-head self-tapping (TA, B) screw and flat washer for replacement
PTTWH		pan-head thread-rolling screw with washer face	binding-head (B) screw and flat washer for replacement
SET SCREWS			
SC		set screw	
SC		hexagon-socket set screw	ex: SC 2.6 x 4, hexagon socket
NUT			
N		nut	
WASHERS			
W		flat washer	
SW		spring washer	
LW		internal-tooth lock washer	ex: LW3, internal
LW		external-tooth lock washer	ex: LW3, external
RETAINING RINGS			
E		retaining ring	
G		grip-type retaining ring	