

SPECIFICATIONS

GENERAL

Power Requirements:	120V ac, 60Hz (*US, Canadian model) 110, 120, 220, or 240V ac 50/60Hz switchable (AEP, UK, E model)
Power Consumption:	30W (US, Canadian model) 33W (AEP, UK, E model)
AC Outlet:	Unswitched 300W total (US, Canadian model)
Dimensions:	Approx. 460(w)x155(h)x325(d)mm 18 1/8(w)x6 1/8(h)x12 7/8(d) inches including projecting parts and controls (US, Canadian model) Approx. 430(w)x155(h)x325(d)mm 17(w)x6 1/8(h)x12 7/8(d) inches including projecting parts and controls (AEP, UK, E model)
Weight:	Approx. 9.4 kg, 20 lb 12 oz. (US, Canadian model) Approx. 8.5 kg, 18 lb 12 oz (AEP, UK, E model)

*Dolby and the double D symbol are the trade marks of
Dolby Laboratories, Inc. Noise reduction system manufac-
tured under license from Dolby Laboratories, Inc.

TAPE RECORDER SECTION

Track:	4-track 2-channel stereo
Fast Forward and Rewind Time:	Approx. 90 seconds with Sony cassette C-60

— Continued on page 2 —



MICROFILM

SERVICE MANUAL

96R

- Frequency Response:** DOLBY NR OFF
- With Ferri-Chrome cassette
 - 20-18,000 Hz
 - 30-16,000 Hz (± 3 dB)
 - 30-16,000 Hz (DIN)
 - With chromium dioxide cassette
 - 20-17,000 Hz
 - 30-15,000 Hz (± 3 dB)
 - 30-15,000 Hz (DIN)
 - With standard cassette
 - 20-15,000 Hz
 - 30-13,000 Hz (DIN)
- Wow and Flutter:** 0.05% WRMS (NAB)
 $\pm 0.14\%$ (DIN)
- S/N Ratio:** DOLBY NR OFF
- With Ferri-Chrome cassette
 - 59 dB at peak level (NAB)
 - 57 dB (DIN, 1975 rev.)
 - With chromium dioxide cassette
 - 57 dB at peak level (NAB)
- DOLBY NR ON
 Improved by 5 dB at 1 kHz,
 10 dB above 5 kHz
- Total Harmonic Distortion:** 1.3%
- Record Bias Frequency:** 105 kHz
- Inputs:** MIC (two phone jacks)
 sensitivity 0.25mV (-70 dB)
 for a low-impedance microphone
- LINE IN (two phono jacks)
 sensitivity 77.5mV (-20 dB)
 input impedance 100k ohms
- Outputs:** VARIABLE LINE OUT (two phono jacks) output level
 0.775V (0 dB) at load impedance
 100k ohms with LINE OUT level control at "10"
 suitable load impedance more than 10k ohms
- FIXED LINE OUT (two phono jacks) output level 0.435V (-5 dB)
 at load impedance 100k ohms
 suitable load impedance more than 10k ohms
- HEADPHONES (binaural jack)
 output level -20 to -50 dB
 at load impedance 8 ohms
- Other Jack:** REC/PB (connector) (UK, AEP, E model)
 input impedance less than 10k ohms
 output impedance less than 10k ohms

0 dB = 0.775 V

● MODEL IDENTIFICATION

—Specification Label—

US, Canadian model

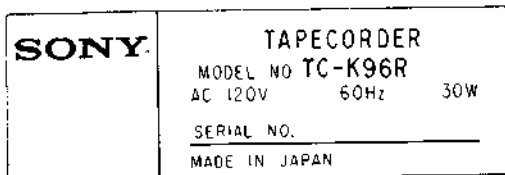

AEP, UK, E model

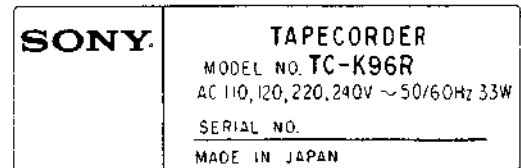

— Power Cord (E model) —

euro-plug (1-551-216-00)

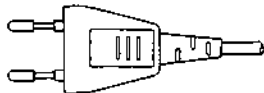

parallel blade plug (1-534-754-00)



MOS IC HANDLING PRECAUTIONS

Since the insulation resistance of the oxidized film of MOS IC is generally very high and the film is extremely thin, the static electric charge on clothing or the body will cause the insulation to breakdown.

IC601 (μ PD547-022) and IC602 (TC4019P) are used for this unit. Observe the following precautions when replacing these ICs:

1. Maintain all the pins at the same potential by wrapping the IC in aluminum foil or other similar material (See Fig. 1).

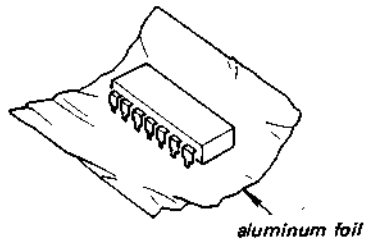

Fig. 1.

2. Ground the work bench for static electricity (See Fig. 2) (Place a sheet of aluminum onto the bench.)

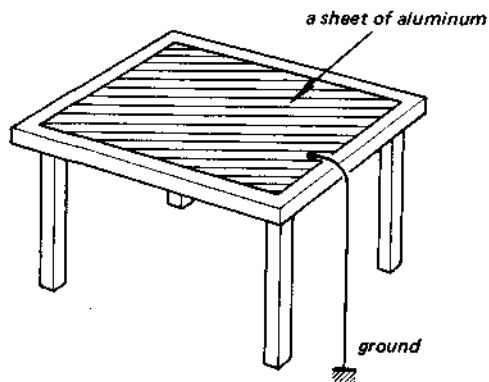

Fig. 2.

3. If necessary to touch the MOS IC direct, grasp the IC at a point other than the pins. Moreover, wear cotton gloves or a cotton finger sack. (Gloves made of nylon or other similar material are undesirable. The static electricity on your body can be easily discharged by wrapping a ground wire around your wrist.)

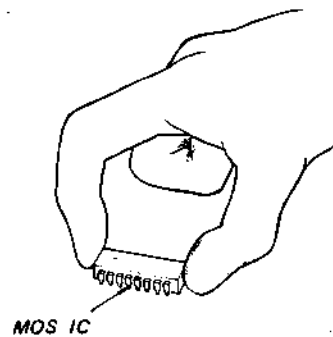

Fig. 3.

4. Short all the pins of the IC before beginning any work. Also ground the soldering iron.

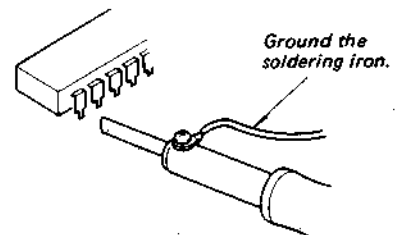
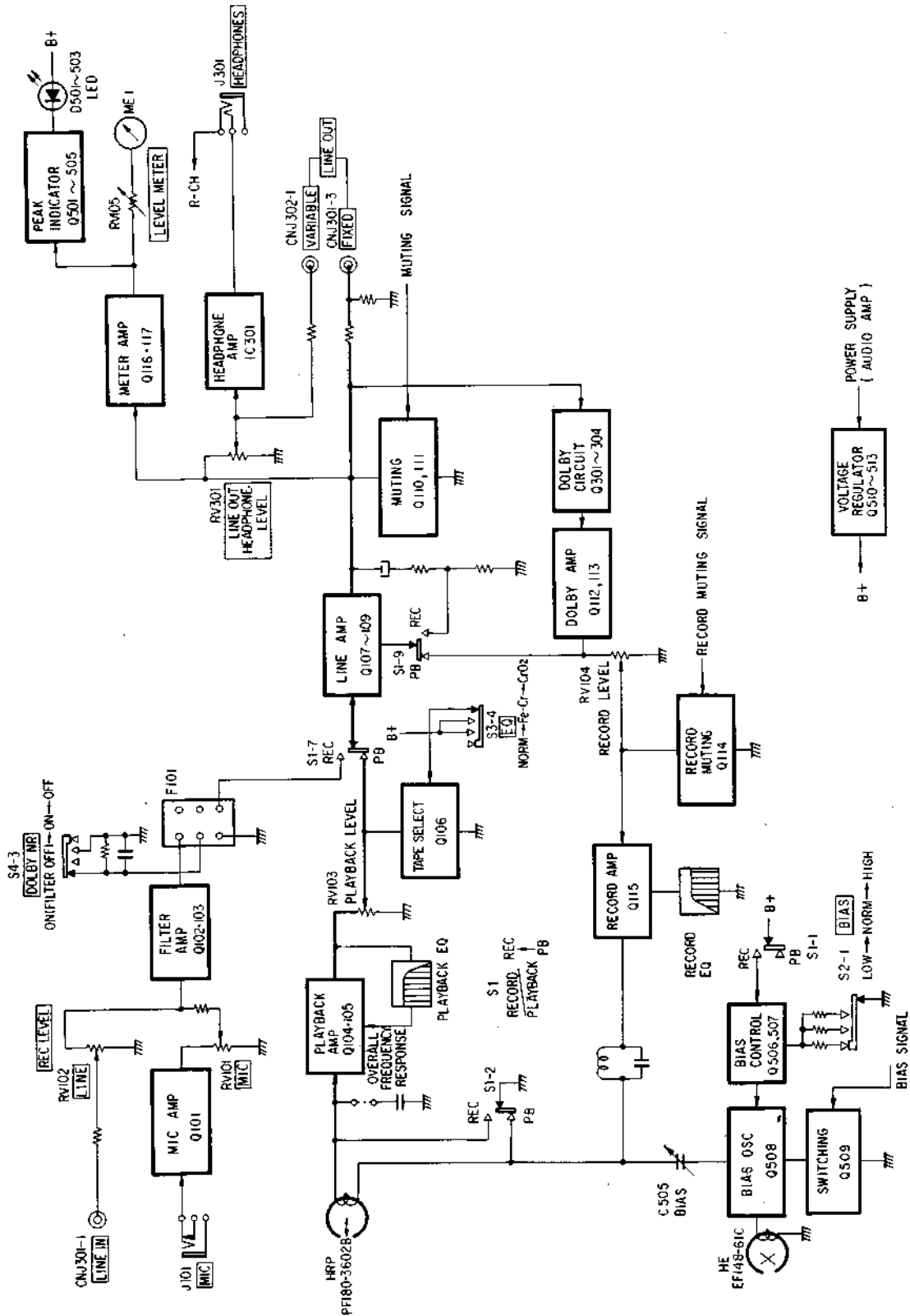

Fig. 4.

SECTION 1
OUTLINE

1-2. BLOCK DIAGRAM -Audio Amp Section-



1-1. BLOCK DIAGRAM —System Control Section—

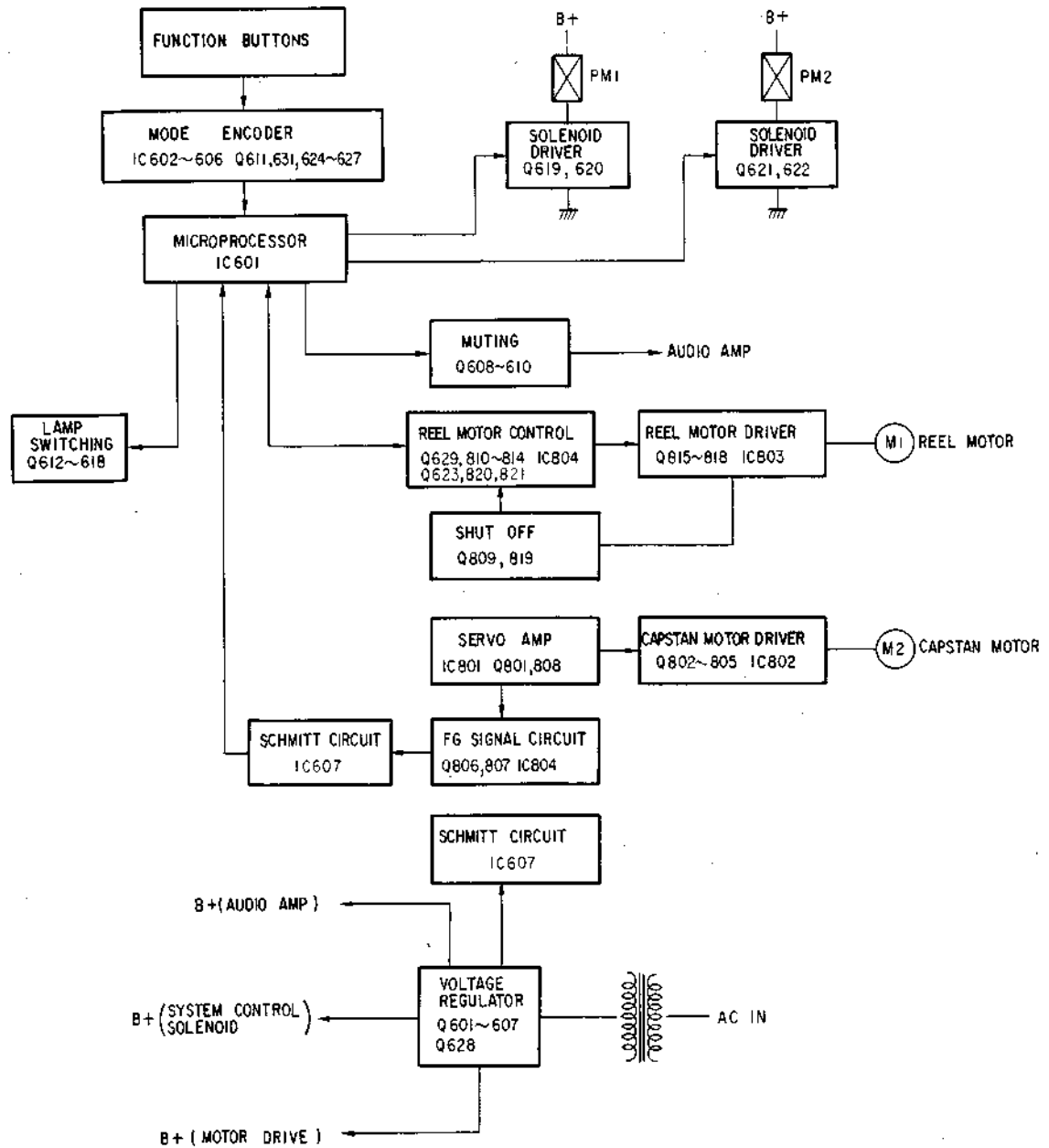

1-3. FUNCTION MECHANISM DESCRIPTION

The solenoid-driven mechanism changes modes from one to another.

Brake Release during fast forward mode and rewind mode. See Fig. 1-1.

1. Depress the function button **▶▶** (FF) or **◀◀** (REW).
2. The plunger, which actuated by the solenoid PM2 supplied with direct current from Q622, moves in the direction shown by the arrow **Ⓐ**. When the brake solenoid slider moves along with the plunger, the head trigger lever moves in the direction shown by the arrow **Ⓑ** and releases the lock of the brake gear.
3. Being pulled by the spring, the brake gear turns in the direction shown by the arrow **Ⓒ** and comes into the drive gear. The brake gear turns furthermore in the direction shown by the arrow **Ⓓ** since the drive gear coupled with the flywheel is rotating in the direction shown by the arrow **Ⓓ**.
4. When the cam pushes the brake arm (A) in the direction shown by the arrow **Ⓔ**, the brake lever moves in the direction shown by the arrow **Ⓕ** and releases the brake.

Note: FWD... forward FF... fast forward
 REV... reverse REW... rewind

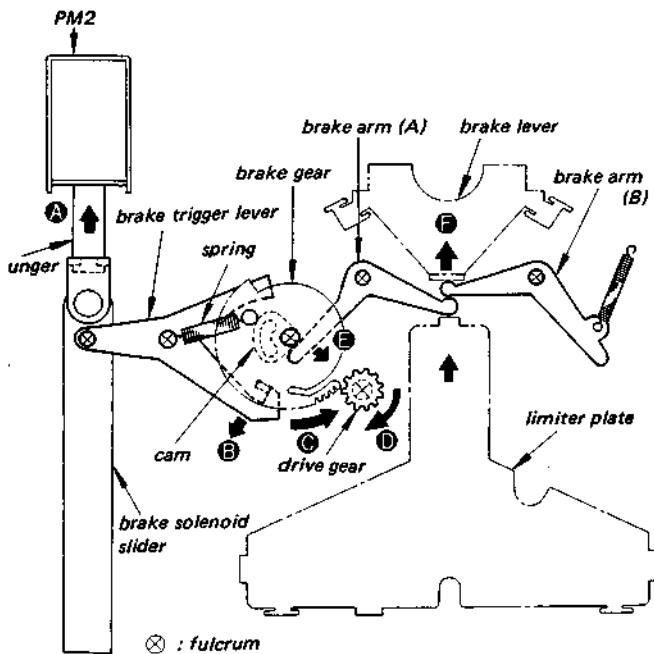

Fig. 1-1

Head Deck Drive during forward mode. See Fig. 1-2.

1. Depress the function button **▶** (FWD).
2. The plunger, which actuated by the solenoid PM 1 supplied with direct current from Q620, moves in the direction shown by the arrow **Ⓐ**. When the head solenoid slider moves along with the plunger, the head trigger lever moves in the direction shown by the arrow **Ⓑ** and releases the lock of the head gear.
3. Being pulled by the spring, the head gear turns in the direction shown by the arrow **Ⓒ** and comes into the drive gear. The head gear turns furthermore in the direction shown by the arrow **Ⓓ** since the drive gear coupled with the flywheel is rotating in the direction shown by the arrow **Ⓓ**.
4. When the cam pushes the head arm (A) in the direction shown by the arrow **Ⓔ**, the limiter plate moves in the direction shown by the arrow **Ⓕ**. Thus, the head deck is lifted and the head contacts the tape.
5. With the limiter plate moving, the brake lever moves in the direction shown by the arrow **Ⓖ** in Fig. 1-1 and releases the brake.

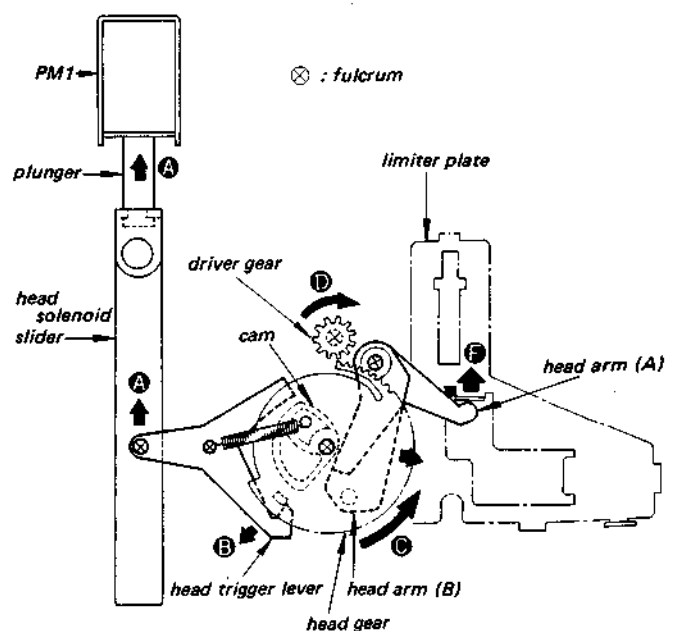

Fig. 1-2

Roto Bilateral Head Mechanism

Transition from FWD mode to REV mode.
See Fig. 1-3.

1. Depress the function button ◀ (REV) or set the DIRECTION MODE switch to make REV mode at the end of a tape in FWD mode.
 2. When the plunger is actuated by the solenoid (PM 1) supplied with direct current from Q620, the head solenoid slider moves in the direction shown by the arrow A.
 3. The head solenoid slider lifts the reverse hook lever and the head gear turns in the direction shown by the arrow B.
 4. With the head gear turning, the cam pushes the head arm (B) in the direction shown by the arrow C and the drive slider also moves in the same direction.
 5. Since the drive slider and the direction slider are connected with the reverse hook lever, the direction slider moves in the direction shown by the arrow D and the bilateral head gear is pushed in the direction shown by the arrow E.
- Consequently, the record/playback head is turned 180-degree and the REV mode is set.

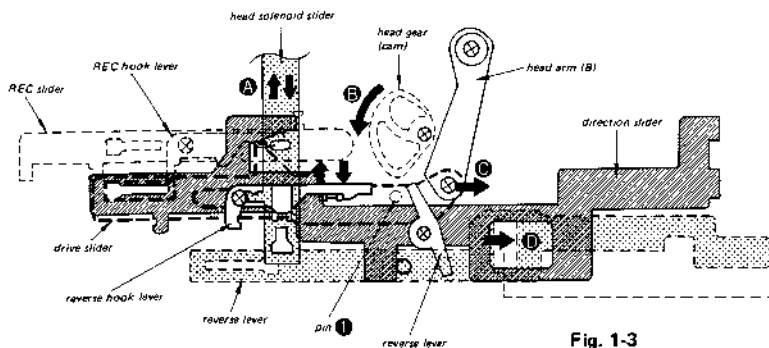

Fig. 1-3

Transition from REV mode to FWD mode
See Fig. 1-4.

1. Depress the function button ▶ (FWD) or set the DIRECTION MODE switch to make FWD mode at the end of a tape in REV mode.
2. When the plunger is actuated by the solenoid (PM 1) supplied with direct current from Q620, the head solenoid slider moves in the direction shown by the arrow F.
3. The head solenoid slider lifts the reverse hook lever and the head gear turns in the direction shown by the arrow G.
4. With the head gear turning, the cam pushes the head arm (B) in the direction shown by the arrow H and the drive slider also moves in the same direction.
5. Since the pin 1 of the drive slider pushes the reverse lever in the direction shown by the arrow I, the pin 2 is pushed in the direction shown by the arrow J and the reverse slider moves in the direction shown by the arrow K.
6. Consequently, when the bilateral head gear is pushed in the direction shown by the arrow L, the record/playback head is turned 180-degrees and the FWD mode is set.

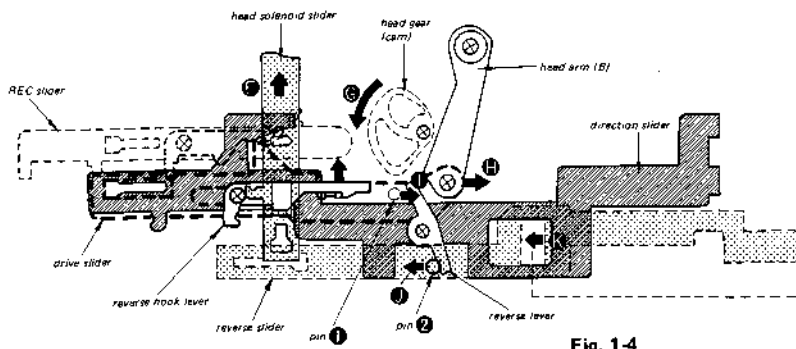
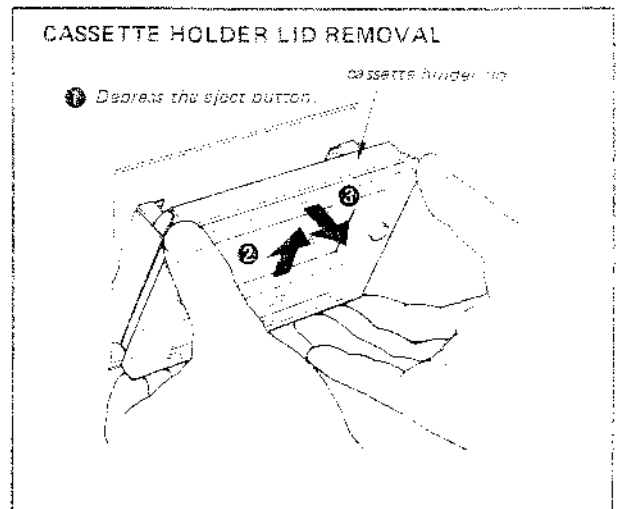
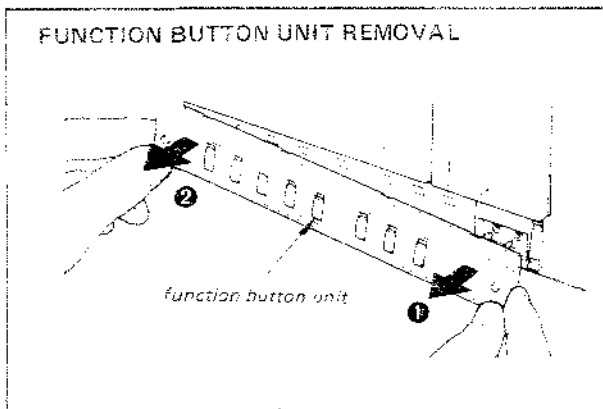
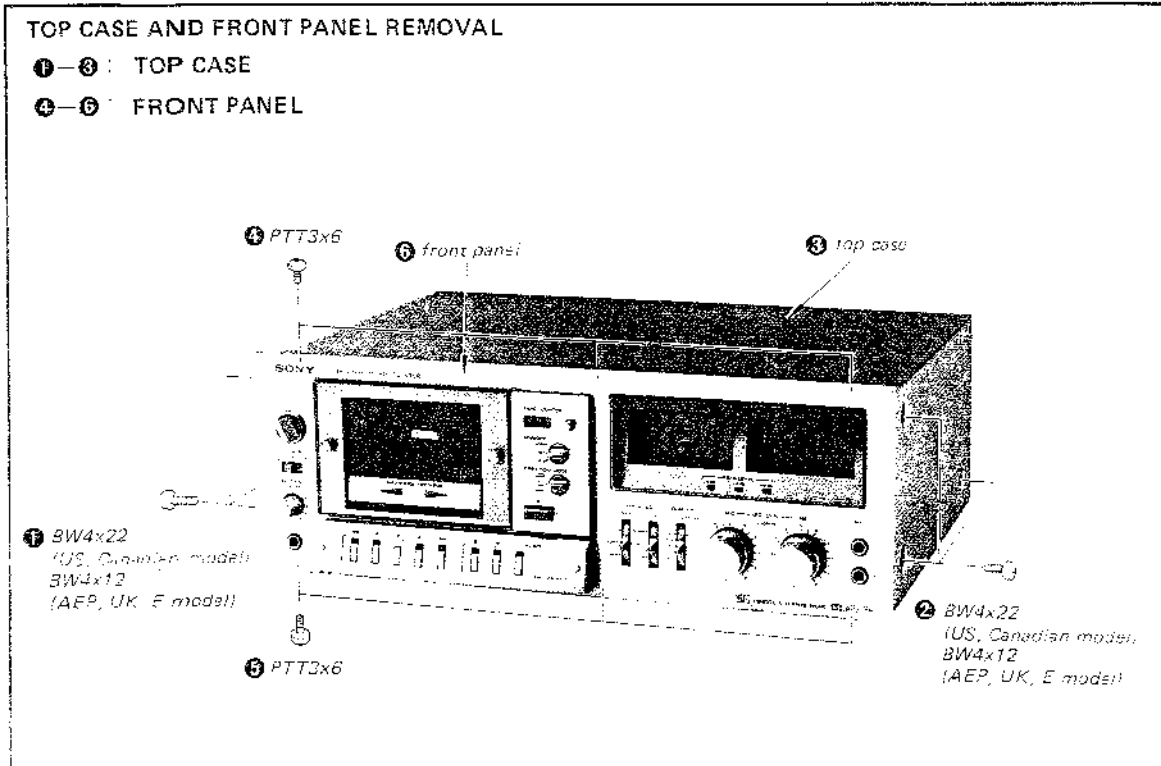
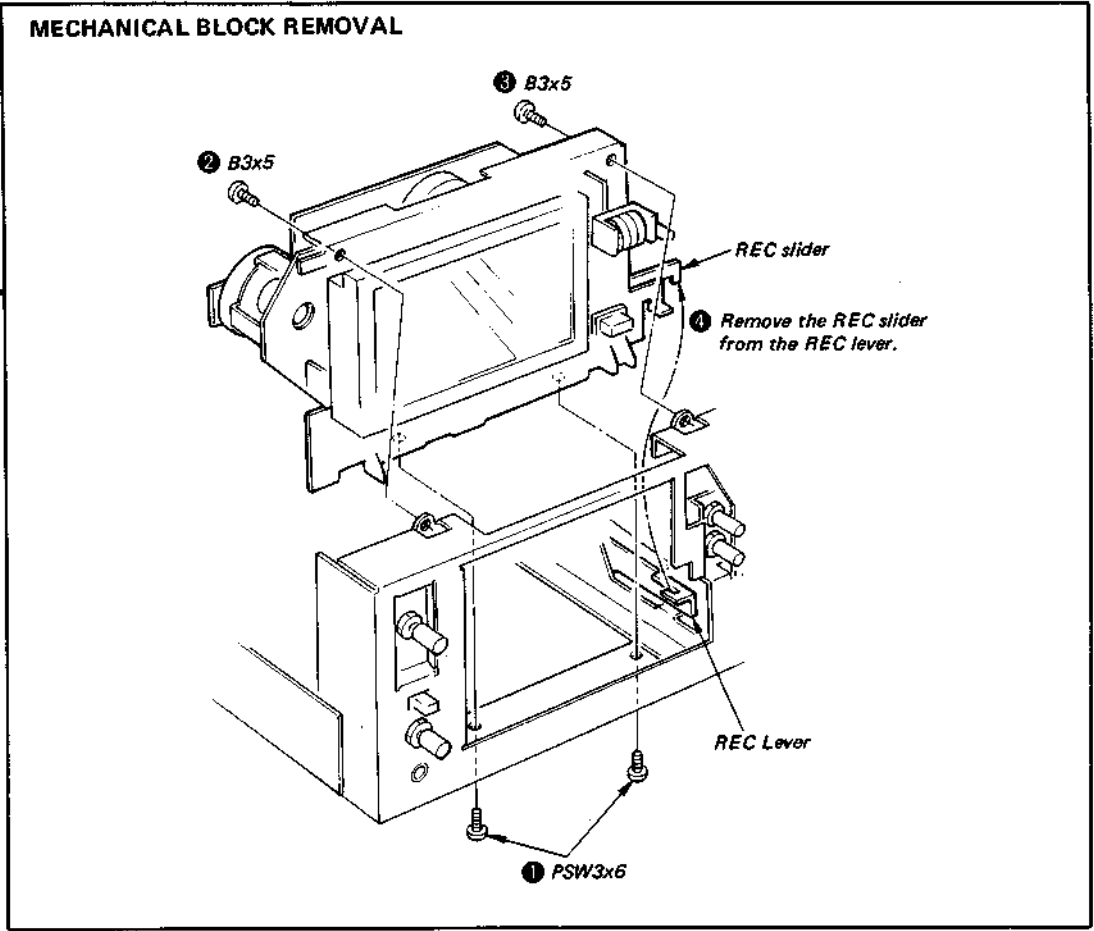

Fig. 1-4

**SECTION 2
DISASSEMBLY**

- Follow the disassembly procedure in the numerical order given.





Solenoid (PM 1, 2) Position Adjustment

1. Insert the plunger of the head solenoid in the direction shown by the arrow.
2. Adjust the position of the head solenoid so that the clearance between the head gear and the head trigger lever is 0.1–0.3 mm.
3. Make sure that the lock lever A is hooked to the protrusion by half when the head gear is turned counterclockwise.
4. Release the plunger of the head solenoid (PM 1).
5. Insert the plunger of the brake solenoid in the direction shown by the arrow.
6. Adjust the position of the brake solenoid so that the clearance between the brake gear and the brake trigger lever is 0.5–1 mm.
7. Make sure that the clearance between the protrusion and the lock lever B is more than 0.2 mm.
8. Release the plunger of the brake solenoid (PM 2).

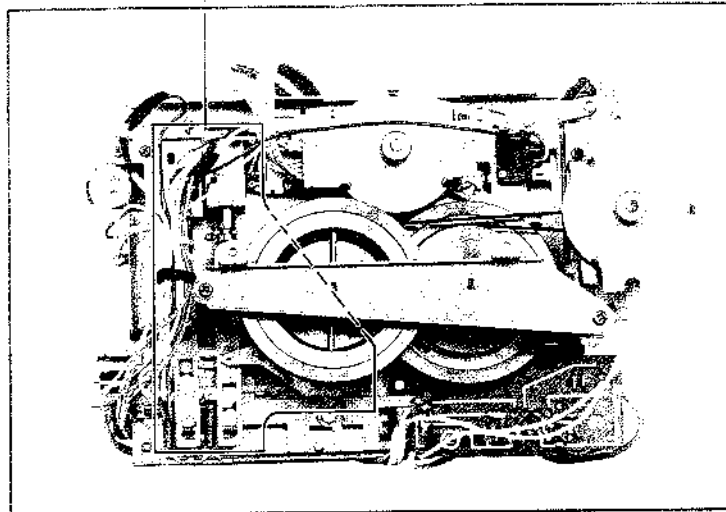
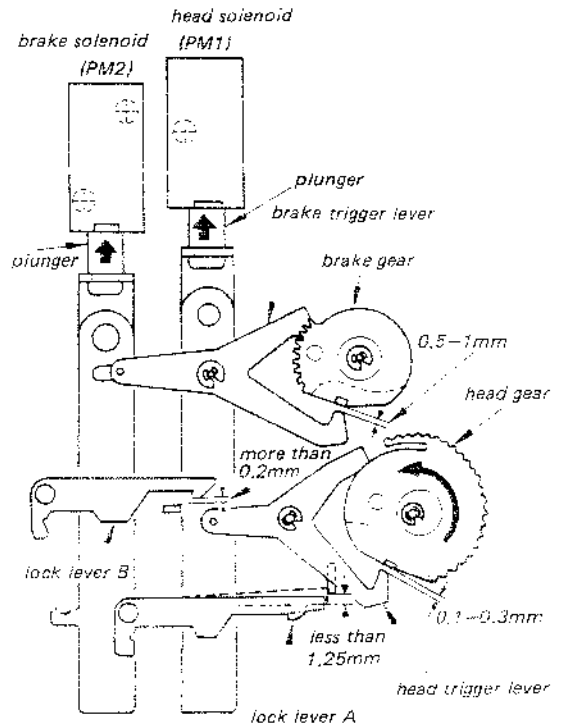

Direction Plate Position Adjustment

1. Turn the rotary-gear by hand in the direction shown by the arrow to set the head in the REV position.
2. Loosen the screw and move the direction plate in the direction shown by the arrow **(A)**.
3. Insert the plunger in the head solenoid and turn the flywheel (R) clockwise. Therefore the direction plate is positioned properly and then tighten the screw.
4. Release the plunger of the head solenoid.
5. Insert the plunger in the head solenoid and turn the flywheel (R) 45° in the direction shown by the arrow.

Next, release the plunger and turn the flywheel (R) 360° in the direction shown by the arrow. Once again, insert the plunger in the head solenoid and make REV mode by turning the flywheel (R).

At this moment, make sure that the clearance **(a)** is less than 1.5 mm and there is a clearance between the bilateral-head gear and the reverse slider.

6. Make FWD mode in the same manner as mentioned in step 3 and confirm that the clearance **(b)** is 0-0.5 mm and there is a clearance between the bilateral head gear and the reverse slider.

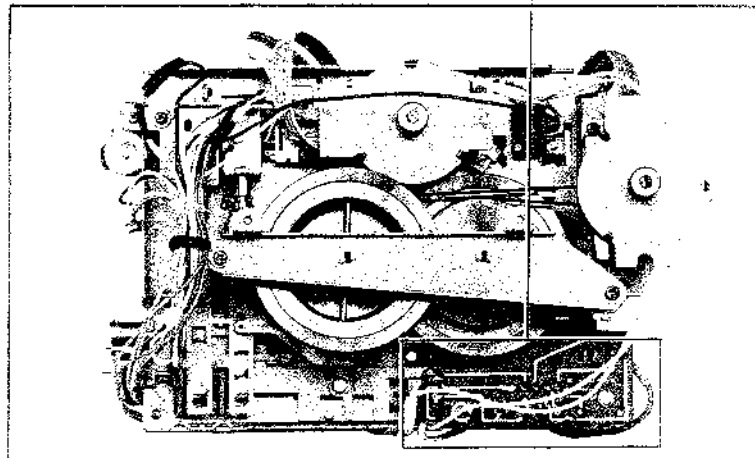
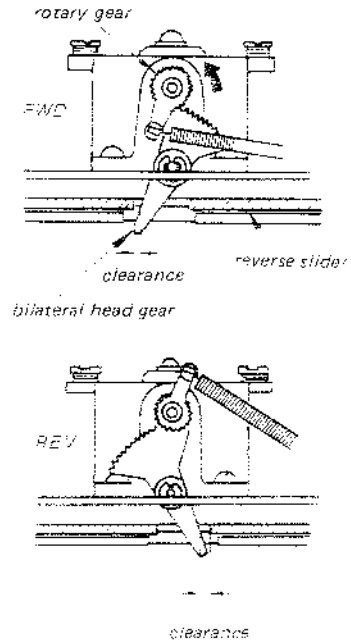
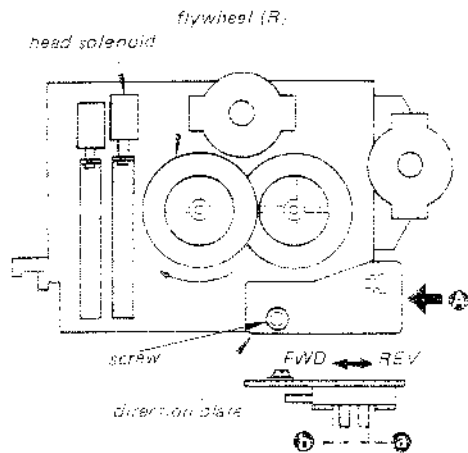

Accidental-Erasure-Proof Switch (S 21, 22) Position Adjustment

1. Install a cassette (with an erasure-proof tab).
2. Adjust the erasure proof switch position so that the clearance between REC detect lever and the erasure proof switch is 0.2 - 0.5 mm.

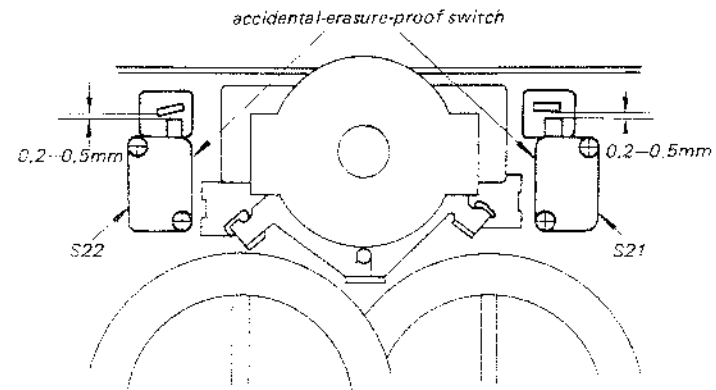

Back Tension Torque Adjustment

1. Install the torque meter CQ-102A and measure the back tension torque in FWD mode. Install the torque meter CQ-101A and measure the back tension torque in REV mode.
 2. To meet the specified torque, change the hook position of the spring.
- Specification: 3-4.5 g.cm

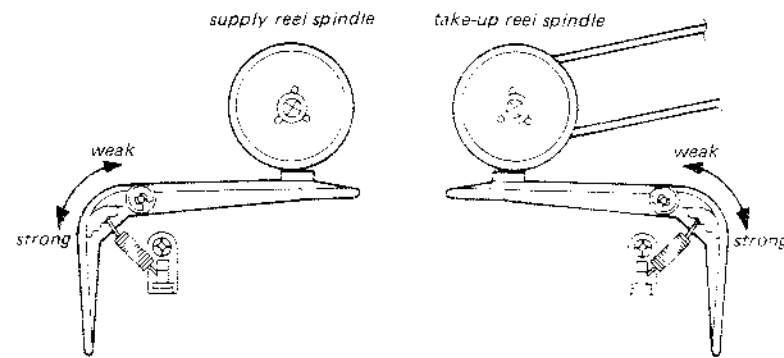

Cassette Lid Switch (S23) Position Adjustment

Adjust the cassette lid switch position so that the clearance **A** is 0-0.4 mm when the cassette lid is opened by pushing EJECT button.

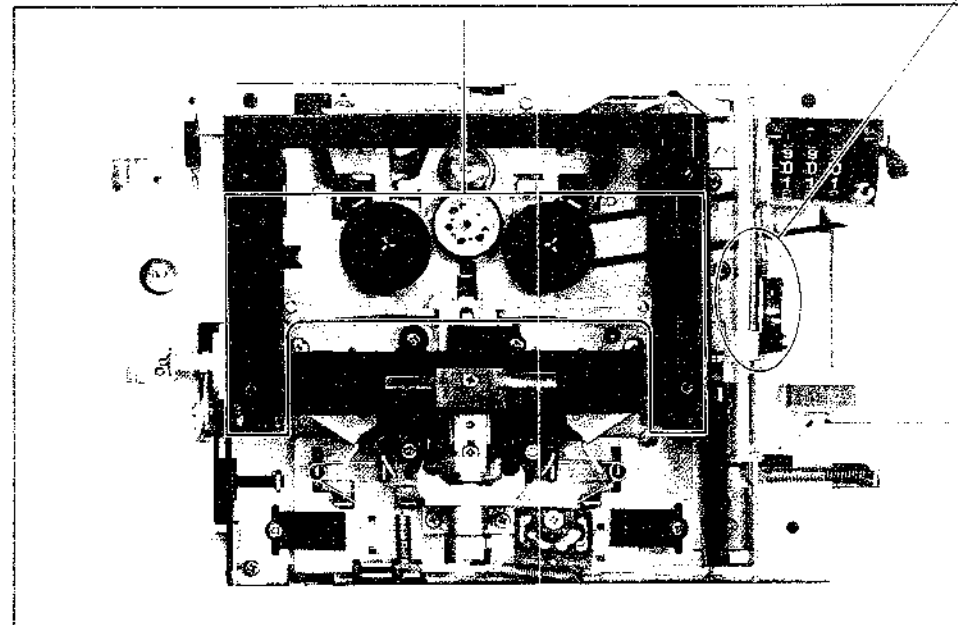
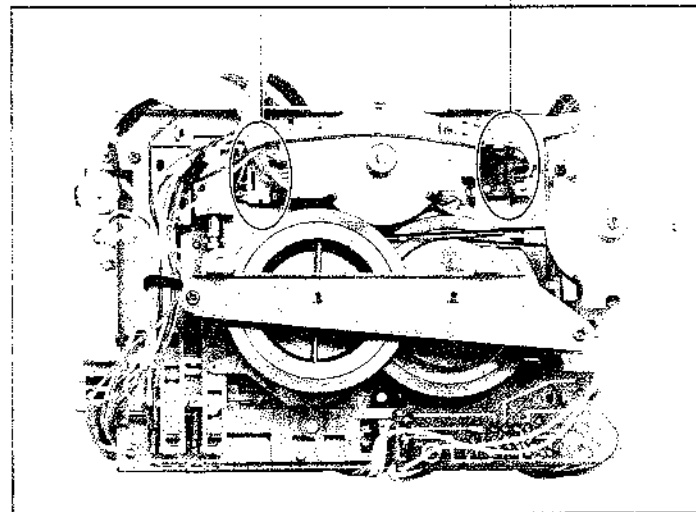
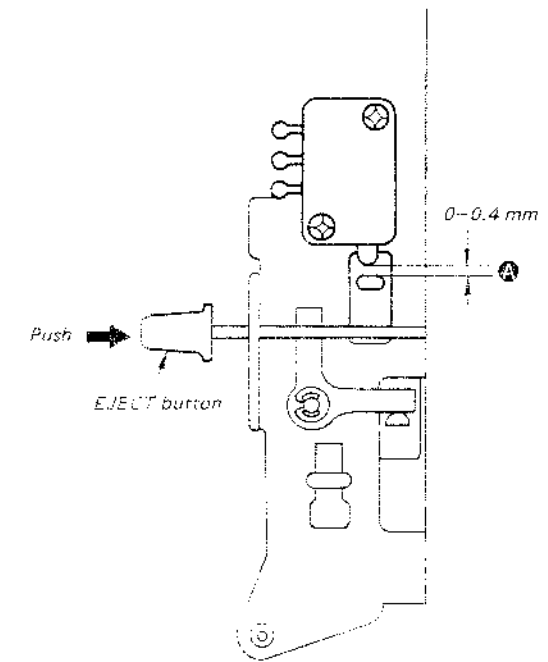

Brake Torque

- Tight side: 50-200 g.cm (0.7-2.8 oz.inch)
- Slack side: 20-100 g.cm (0.28-1.4 oz.inch)

Pinch Roller Pressure

4.0-5.0 g.cm (0.5-0.75 oz.inch)

3.2. ELECTRICAL ADJUSTMENTS

Note: The adjustment should be performed in the order given in this service manual. The adjustments should be performed for both L-CH and R-CH.

BIAS and EQ switch settings in accordance with tape used are as follows.

Tape	BIAS switch	EQ switch
CS-10	NORMAL	NORMAL
CS-20	HIGH	CrO ₂
CS-30	NORMAL	Fe-Cr

Switches and controls should be set as follows unless otherwise specified.

DOLBY NR switch:	OFF
EQ switch:	NORMAL
BIAS switch:	NORMAL
LINE OUT/HEADPHONES LEVEL:	MAX (fully clockwise)
TIMER switch:	OFF
MEMORY switch:	OFF
REC MUTE switch:	OFF
MODE switch:	—

Standard Record:

Supply the standard input signal level to the input jack and set the REC LEVEL control to obtain the standard output signal level.

Standard Input Level

	MIC	LINE IN
source impedance	300Ω	10 kΩ
input level	-60 dB (0.775V)	-10 dB (0.316V)

Standard Output Level

	LINE OUT VARIABLE	LINE OUT FIXED	HEAD- PHONES
load impedance	100 kΩ	100 kΩ	kΩ
output level	0 dB (0.775V)	-5 dB (0.44V)	

Capstan Motor Adjustment

1. Disconnect the 2-p connector and apply 1.5V dc between IN pin of the connector and TP800.

Terminal	Adjust	Specifications
TP801	RV819	A = B
	RV810	10Vp-p
TP802	RV816	A = B
	RV809	10Vp-p

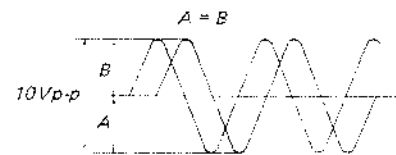

2. Plug in the 2-p connector, insert a cassette tape and set in FWD mode.

Adjust RV819 so that the positive peak voltage of TP802 equals the positive peak voltage of TP801.

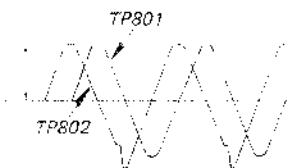

Adjustment Location

Servo Amp Board

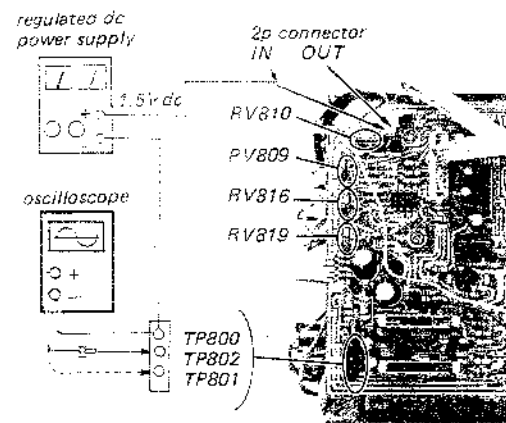

Recel Motor Adjustment

1. Run the set in FWD mode without loading a cassette.

a)

Terminal	Adjust	Specifications
TP851	RV860	A = B
TP852	RV874	A = B

b) Adjust RV854 so that the voltage at TP851 equals the voltage at TP852.

2. Run the set in REV mode without loading a cassette.

Terminal	Adjust	Specifications
TP851	RV861	A = B
TP852	RV875	A = B

3. Install the torque meter CQ-101A and adjust RV843 to obtain 45-50 g.cm (0.62-0.69 oz. inch) torque in FWD mode.

Make sure that REV torque is 42-55 g.cm (0.58-0.76 oz. inch).

4. Install a cassette and repeat the steps 1-a and 2.

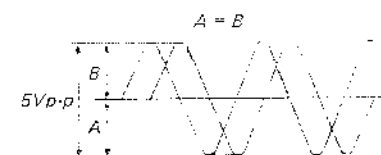

Adjustment Location:

Servo Amp board

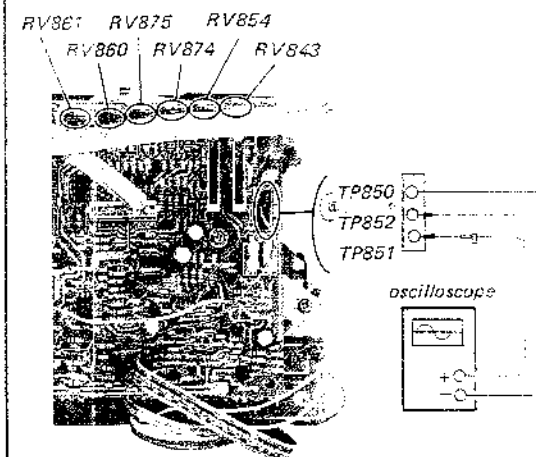

Tape Speed Adjustment

Procedure:

Mode: Playback



Adjust RV806 to obtain the specified values.

Specification:

Speed checker	Digital frequency counter
-0.7 - +0.7%	2,980 - 3,020 Hz

Frequency difference between beginning and end of tape should be within 0.7% (20 Hz).

Adjustment Location

Servo Amp Board

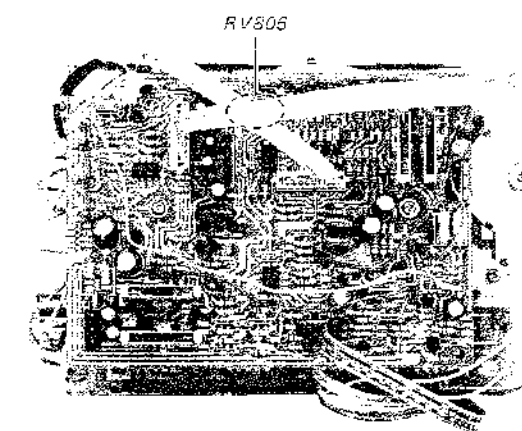

Record/playback Head Azimuth Adjustment

Procedure:

1. Mode: Playback

test tape
P-4-A81
(6.3 kHz, -10 dB)

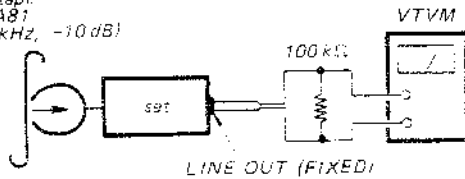

2. Turn the adjustment screw for the maximum level and set it to the mechanical mid position between L-CH and R-CH peak position.

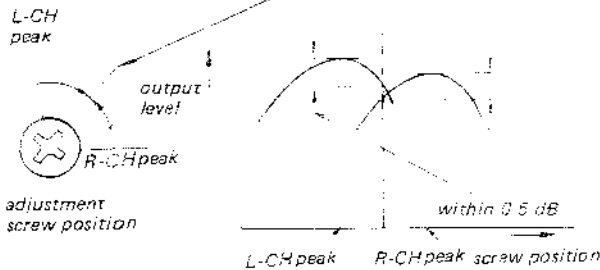

3. Mode: Playback

test tape
P-4-A81
(6.3 kHz, -10 dB)

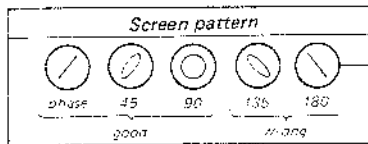
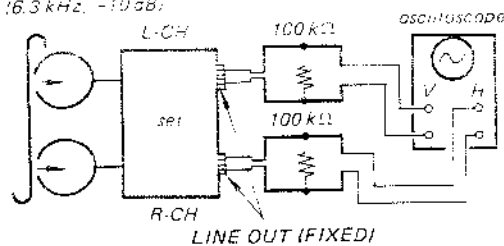

Adjustment Location:

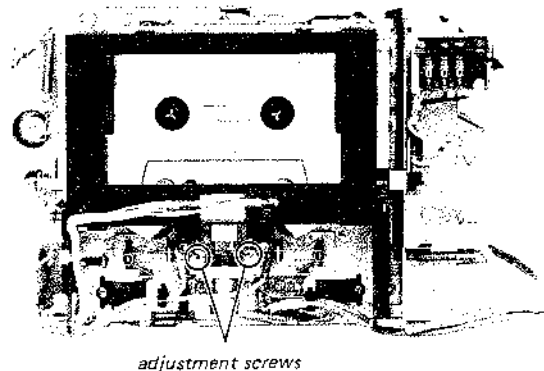

Playback Level Adjustment

Procedure:

1. Mode: Playback

P-4-L81
(333 Hz, 0 dB)

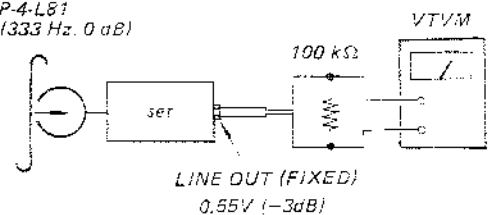

Adjust RV103 (L-CH) and RV203 (R-CH) to obtain the specified values.

Specification:

LINE OUT level: 0.52-0.58 V
(-2.5 to -3.5 dB)

Check that LINE OUT level does not change to playback mode while changing the mode from playback to stop several times.

Adjustment Location:

- Audio Amp Board -

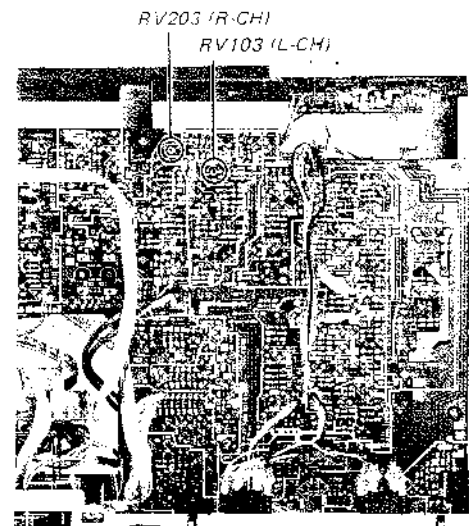

Playback Equalizer Adjustment

Procedure:

Mode: Playback

test tape
P-4-A82
(110 kHz, -10 dB)

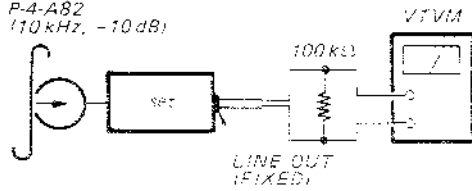

Solder or unsolder the patterns at **A** to obtain specified values.

Specification:

EQ switch	LINE OUT (FIXED) level
NORMAL	0.15 - 0.20 V (-14.5 to -11.5 dB)
Fe-Cr or Cr-02	0.085 - 0.12 V (-18 to -16 dB)

Adjustment Location: - Audio Amp Board -

Bridge patterns	LINE OUT (FIXED) level
(open)	up
A	down

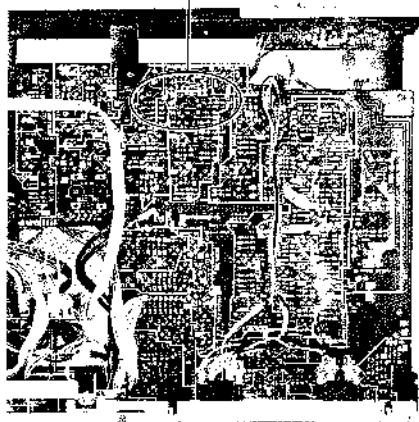
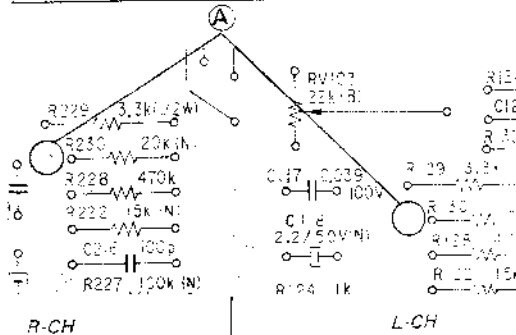

Level Meter Calibration

Procedure:

1. Mode: Standard record (See page 15.)

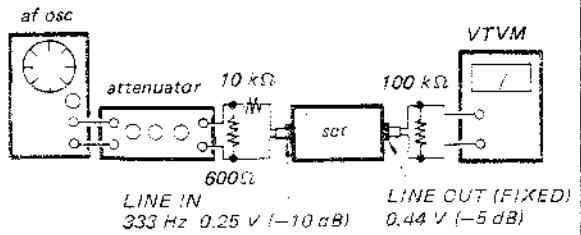

Adjust	Level meter reading: 0 VU
RV105 (L-CH)	
RV205 (R-CH)	

Adjust RV105 (L-CH) and RV205 (R-CH) to obtain 0 VU reading on the level meter

Adjustment Location: - Audio Amp Board -

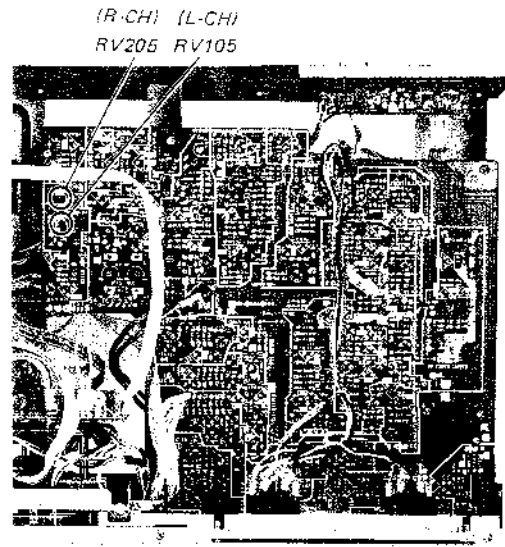

Record Bias Adjustment

Procedure:

1. Mode: Standard record (See page 15.)

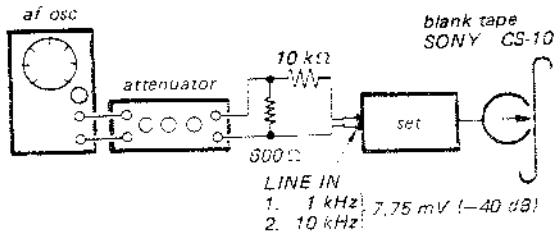

2. Mode: Playback

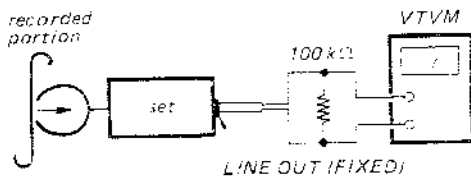

Adjust C505 (L-CH) and C506 (R-CH) to make 10 kHz and 1 kHz signal output levels equal.

Unsolder the pattern **A**.

In REC·FWD mode, read the voltage across R526

In REC·REV mode, adjust RV501 to make the voltage across R526 the same reading obtained in REC·FWD mode. After the adjustment, bridge the pattern at **A**.

Adjustment Location: -- Audio Amp Board --

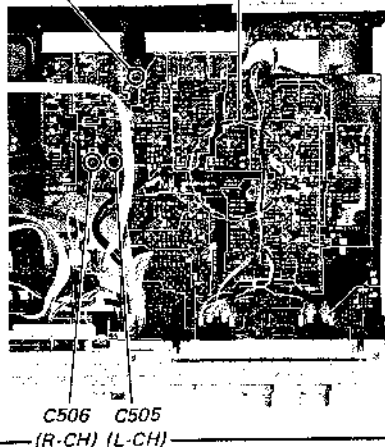
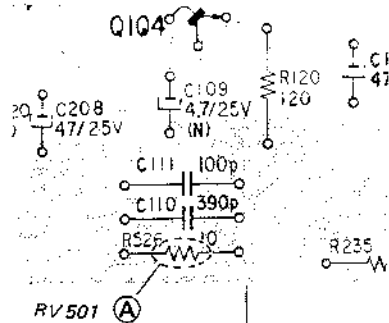

Record Level Adjustment

Procedure:

1. Mode: Standard record (See page 15.)

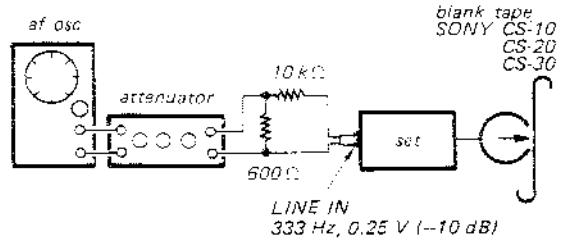

2. Mode: Playback

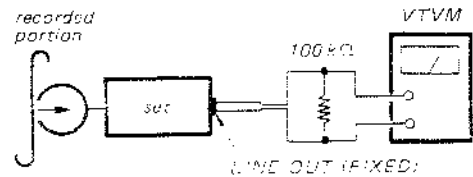

Adjust RV104 (L-CH) and RV204 (R-CH) to obtain the specified values.

Specification:

Tape	LINE OUT Level
CS-10	0.39 - 0.49 V (-6 to -4 dB)
CS-20	0.38 - 0.52 V
CS-30	(-6.5 to -3.5 dB)

Level difference between FWD and REV mode: less than 1 dB

Adjustment Location: -- Audio Amp Board --

RV204 (R-CH)

RV104 (L-CH)

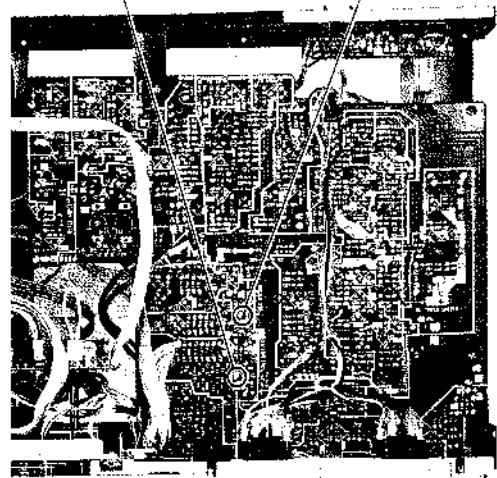

Overall Frequency Response Adjustment

Procedure:

1. Mode: Standard record (See page 15)

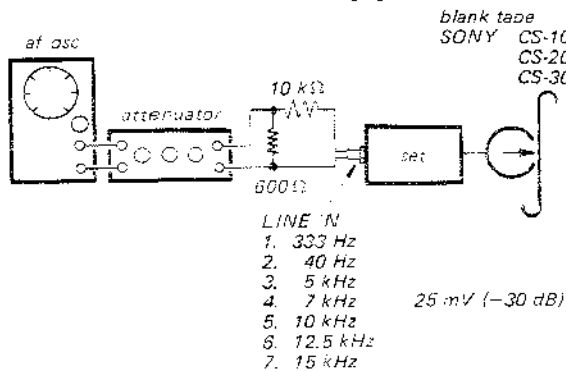

3. Measure the output level deviation of the each frequency from the output level of 333 Hz signal. The deviation should be as following table.

freq. \ Tape	CS-10	CS-20	CS-30
40 Hz			
5 kHz		0 ± 0 dB	
7 kHz			
10 kHz			
12.5 kHz	-1 ± 3 dB	0 ± 3 dB	
15 kHz		0 +3 -5 dB	

If the 15 kHz level is out of the specification, adjust by bridging patterns

2. Mode: Playback

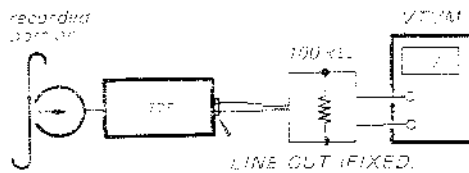

Adjustment Location - Audio Amp Board -

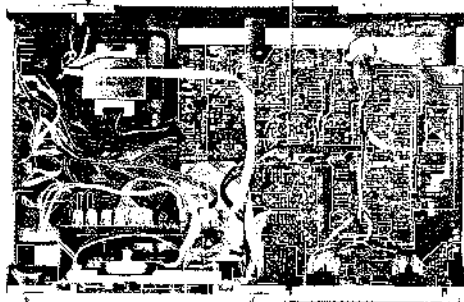
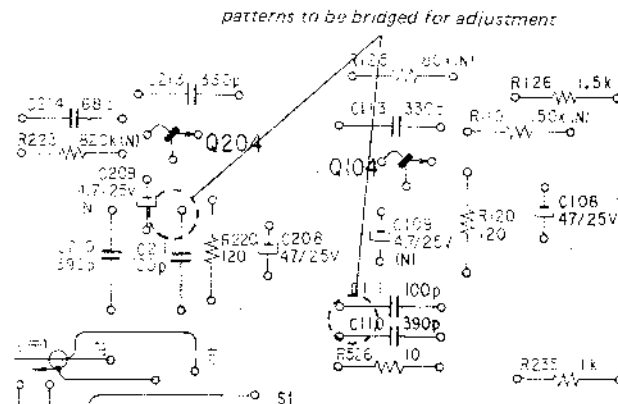

SECTION 4
DIAGRAMS

• Replacement Semiconductors

For replacement, use semiconductors except in ().

Q601 : 2SC1173

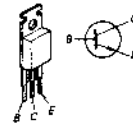

Q602 : 2SC1061 (2SC1419)

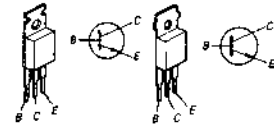

Q603, 607-619
Q621, 624-627, 631
Q801, 808, 810
Q820, 821, 629

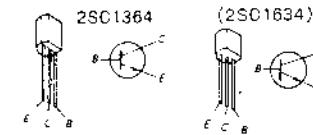

Q604 : 2SA678

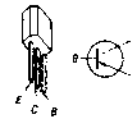

Q605, 606 : 2SB605

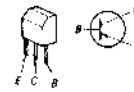

Q620, 622
Q628

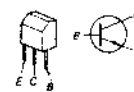

Q803, 804
Q816, 817

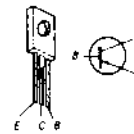

Q802, 805
Q815, 818

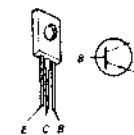

Q806, 807
Q809, 813

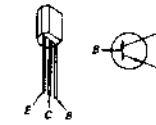

Q811, 812 : 2SC1364 (2SC634A)

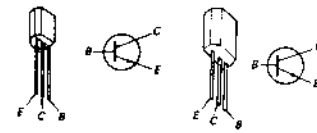

Q814, 819 : 2SA678 (2SA677)

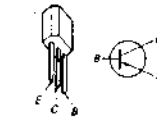

IC601 : μ PD547-022

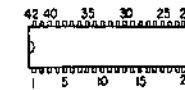

(Top view)

IC602 : TC4019P

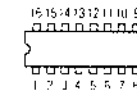

(Top view)

IC607 : TC4069P

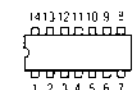

(Top view)

IC801 : CX-065A

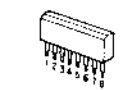

IC802-804 : μ PC4558C (μ PC4558)
IC803-806 : μ PC4557C (μ PC4557)

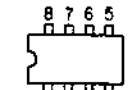

(Top view)

Note: The components identified by shading and mark are critical for safety. Replace only with part number specified.

Note: Les composants identifiés par un trame et une marque sont critiques pour la sécurité. Ne les remplacer que par une pièce portant le numéro spécifié.

D608 : EQB01-15 (EQA01-15R)
D611 : EQB01-11Z (EQA01-11R)



D605, 606 : S1VB10

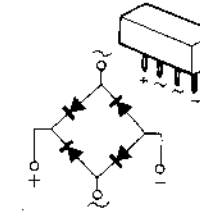

D601-804, 807 : 10E2
D609, 619, 620 : 1S1555 (1T40)
D627 : 1S1555 (1T40)
D801-809 : 1S1555
D612-618 : 1S1555
D621-623 : 1S1555
D626



- All capacitors are in μ F unless otherwise noted. pF = μ μ F. 50 WV or less are not indicated except for electrolytics.
- All resistors are in ohms, $\frac{1}{4}$ W unless otherwise noted. k Ω = 1000 Ω , M Ω = 1000 k Ω .
- : nonflammable resistor.
- : fusible resistor.
- : B+ bus.
- : adjustment for repair.
- : B--bus.
- Voltages are dc with respect to ground unless otherwise noted.
- Readings are taken under no signal conditions with a VOM (20 k Ω /V).
- : Forward
- : Fast Forward
- : Reverse
- : Rewind
- no mark: stop

[]: Voltages taken from the indicated points to the ground of servo amplifier circuit in forward mode.

Note:

(The ground of servo amplifier circuit is isolated from the chassis ground which has zero potential. The difference in voltage between these two grounds is approximately 10V.)

- Voltage variations may be noted due to normal production tolerances.

SYSTEM CONTROL BOARD

**SECTION 4
DIAGRAMS**

Replacement Semiconductors

For replacement, use semiconductors except in ().

Q601 : 2SC1173

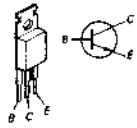

Q806, 807 } 2SC1364 (2SC945)
Q809, 813 }

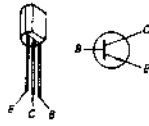

Q602 : 2SC1061 (2SC1419)

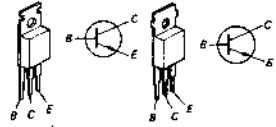

Q811, 812 : 2SC1364 (2SC634A)

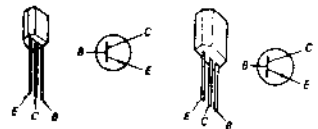

Q603, 607-619
Q621, 624-627, 631
Q801, 808, 810
Q820, 821, 629

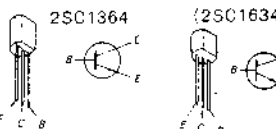

Q814, 819 : 2SA678 (2SA677)

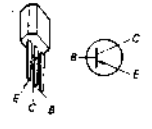

Q604 : 2SA678

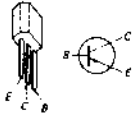

IC601 : μ PD547-022

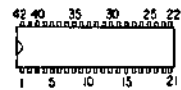

(Top view)

Q605, 606 : 2SB605

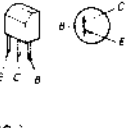

IC602 : TC4019P



(Top view)

Q820, 622 } 2SD571
Q628

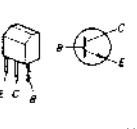

IC607 : TC4069P

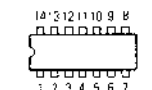

(Top view)

Q803, 804 } 2SB548
Q816, 817 }

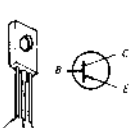

IC801 : CX-065A

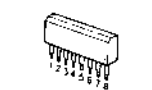

Q802, 805 } 2SD414
Q815, 818 }

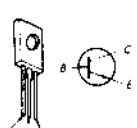

IC802-804 : μ PC4558C (μ PC4558)

IC603-608 : μ PC4557C (μ PC4557)

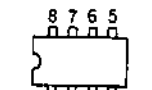

(Top view)

Note: The components identified by shading and mark Δ are critical for safety. Replace only with part number specified.

Note: Les composants identifiés par un trame et une marque Δ sont critiques pour la sécurité. Ne les remplacer que par une pièce portant le numéro spécifié.

D608 : EQB01-15 (EQA01-15R)
D611 : EQB01-11Z (EQA01-11R)

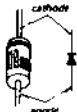

D605, 606 : S1VB10

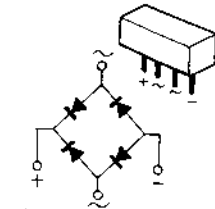

D601-604, 607 } 10E2
D609, 619, 620 }
D627 : 1S1555 (1T40)
D801-809 } 1S1555
D812-818 }
D821-823 }
D626 }

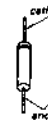

- All capacitors are in μ F unless otherwise noted. pF = μ μ F. 50 WV or less are not indicated except for electrolytics.
- All resistors are in ohms, $\frac{1}{4}$ W unless otherwise noted. k Ω = 1000 Ω , M Ω = 1000 k Ω .
- : non-flammable resistor.
- : fusible resistor.
- : B + bus.
- : adjustment for repair.
- : B--bus.
- Voltages are dc with respect to ground unless otherwise noted.
- Readings are taken under no signal conditions with a VOM (20 k Ω /V).

- ▶ : Forward
- ▶▶ : Fast Forward
- ◀ : Reverse
- ◀◀ : Rewind
- no mark : stop

[] : Voltages taken from the indicated points to the ground of servo amplifier circuit in forward mode.

Note:
(The ground of servo amplifier circuit is isolated from the chassis ground which has zero potential. The difference in voltage between these two grounds is approximately 10V.)

- Voltage variations may be noted due to normal production tolerances.

4-1. SCHEMATIC DIAGRAM - Servo Amp Section-

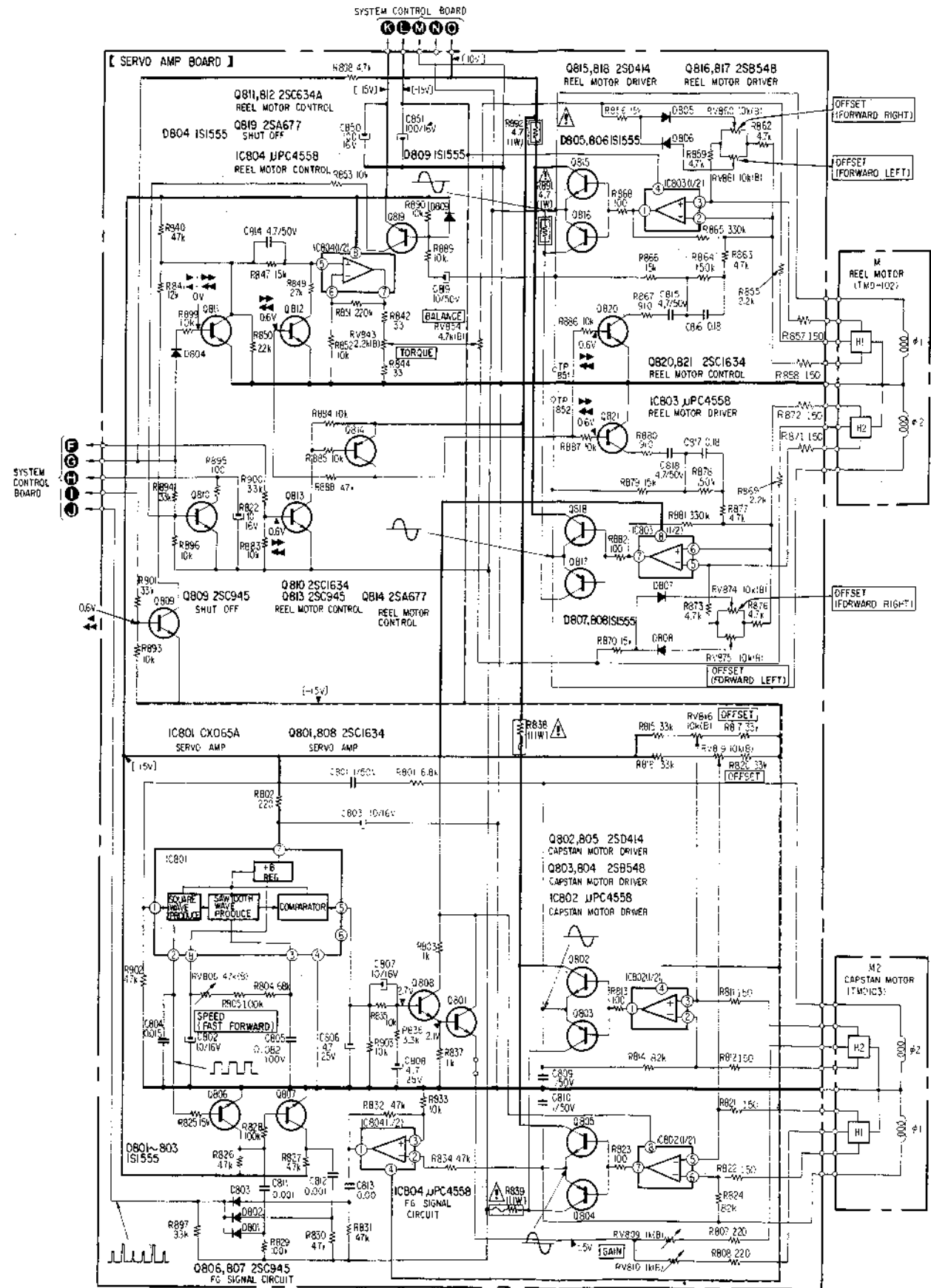

2-2. SCHEMATIC DIAGRAM —System Control Section—

- All capacitors are in μF unless otherwise noted. $\text{pF} = \mu\mu\text{F}$. 50 WV or less are not indicated except for electrolytics.
- All resistors are in ohms, $\frac{1}{4}\text{W}$ unless otherwise noted. $\text{k}\Omega = 1000\Omega$, $\text{M}\Omega = 1000\text{k}\Omega$.

- : panel designation
- : nonflammable resistor.
- (N) : low-noise resistor.
- : B + bus.
- Readings are taken under no signal conditions with a VOM (20 $\text{k}\Omega/\text{V}$).
- : Rewind
- : Reverse
- : Forward
- : Fast Forward
- : record
- : pause
- : rec mute
- : stop
- Voltage variations may be noted due to normal production tolerances.
- Switch

Ref. No.	Switch	Position
S10-15	FUNCTION	FORWARD
S16	PAUSE	OFF
S17	REC MUTE	OFF
S18	TIMER	OFF
S19	MEMORY	OFF
S20	DIRECTION MODE	
S21	REVERSE	OFF
S22	ERASER PROOF	FORWARD
	ERASER PROOF	OFF
S23	CASSETTE LID	OFF
S24	TAPE COUNTER	OFF
S25	DIRECTION	FORWARD
S26	POWER	OFF

Note: The components identified by shading and mark are critical for safety. Replace only with part number specified.

Note: Les composants identifiés par un trame et une marque sont critiques pour la sécurité. Ne les remplacer que par une pièce portant le numéro spécifié.

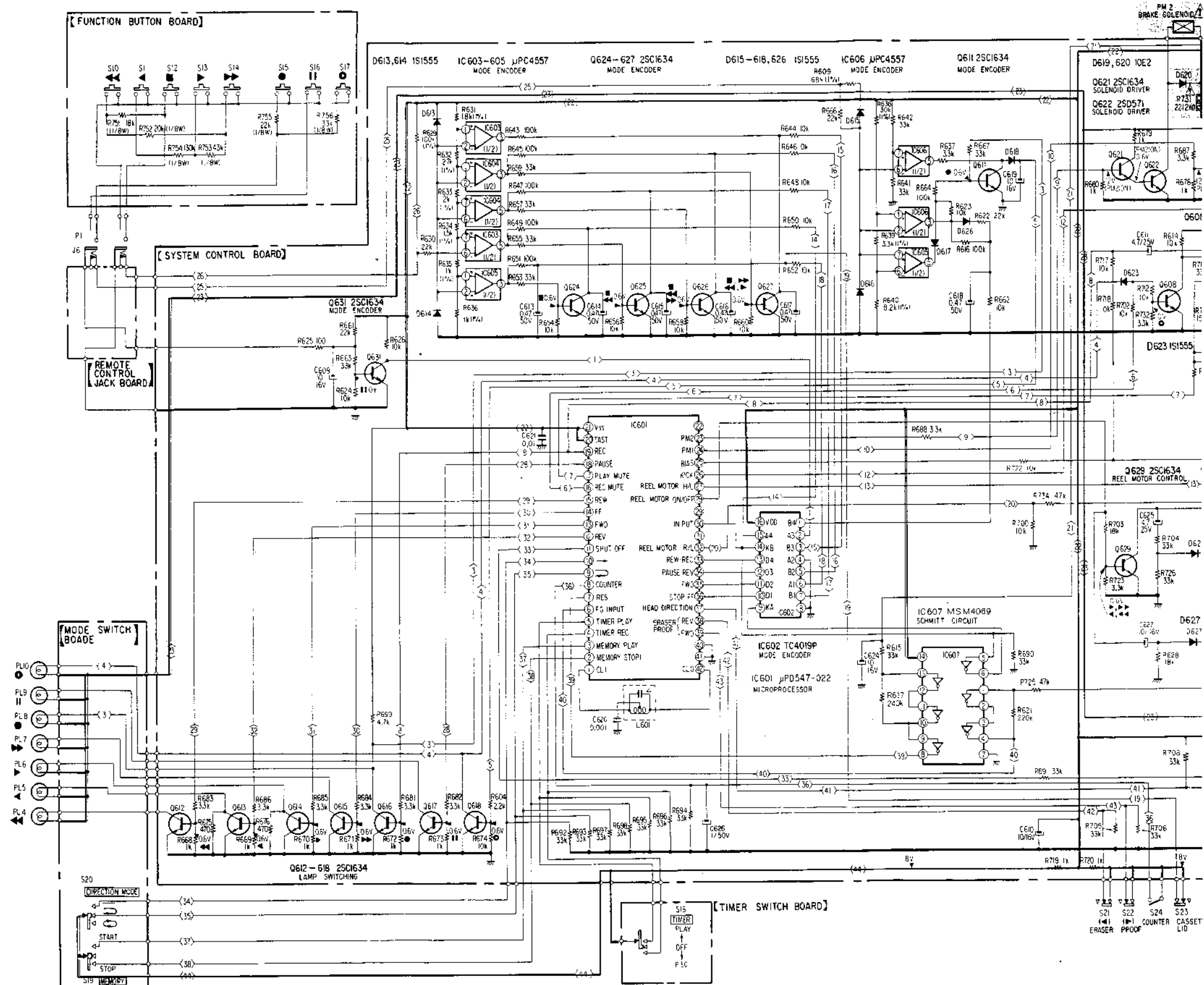

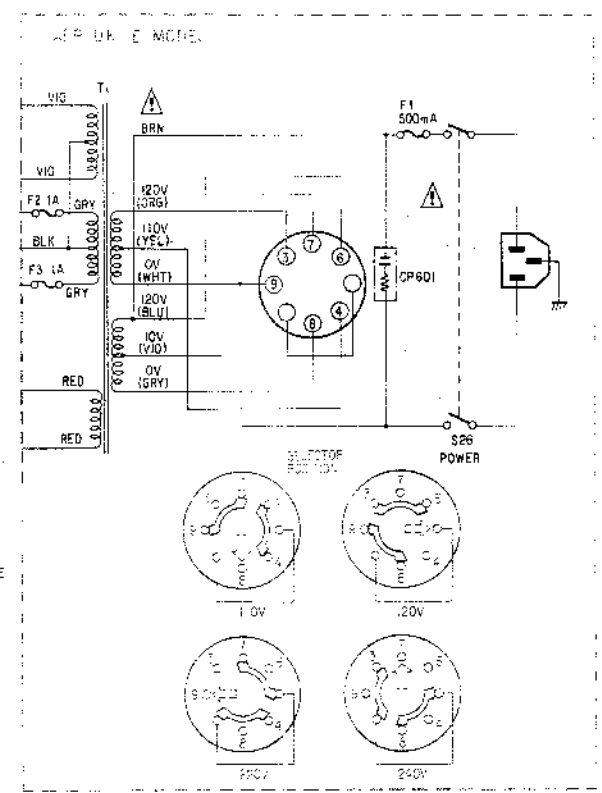
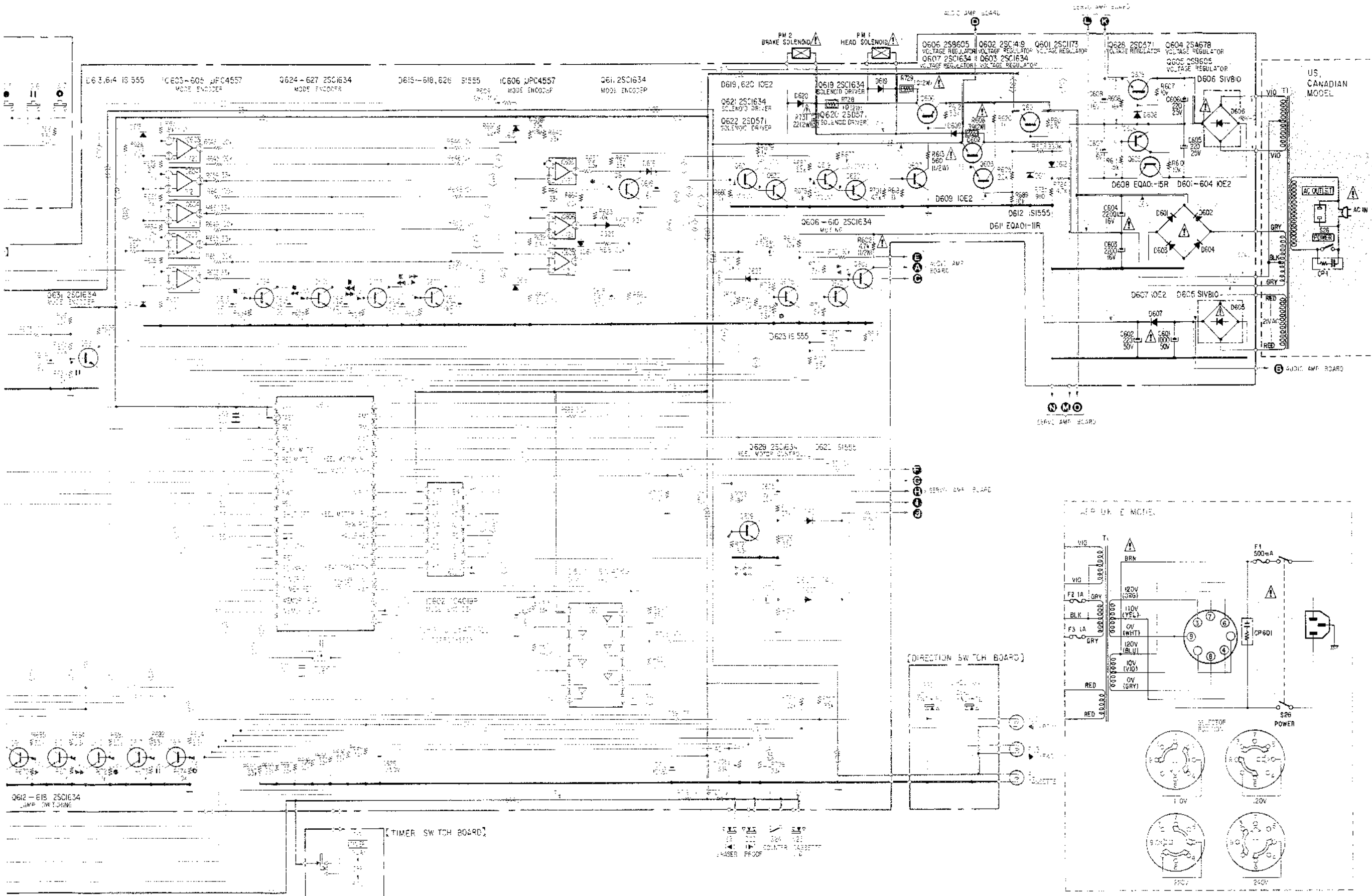

4.3 MOUNTING DIAGRAM --System Control Section--

Conductor Side--

Q, IC	Q
603, 602	611
601	
605	601
604	606, 602
	603
609	608, 604
610	
628	612
607	605
IC607	
520, 619	609
608	
606	
623	619
622, 62	
629	
61	520, 618
625	62
626	
IC 624, 606	626, 622
618	
IC IC 602, 605	617
612	
63	
IC601	
IC IC 603, 604	
613	
615	
61E	612, 616
	613, 614
614	
617	

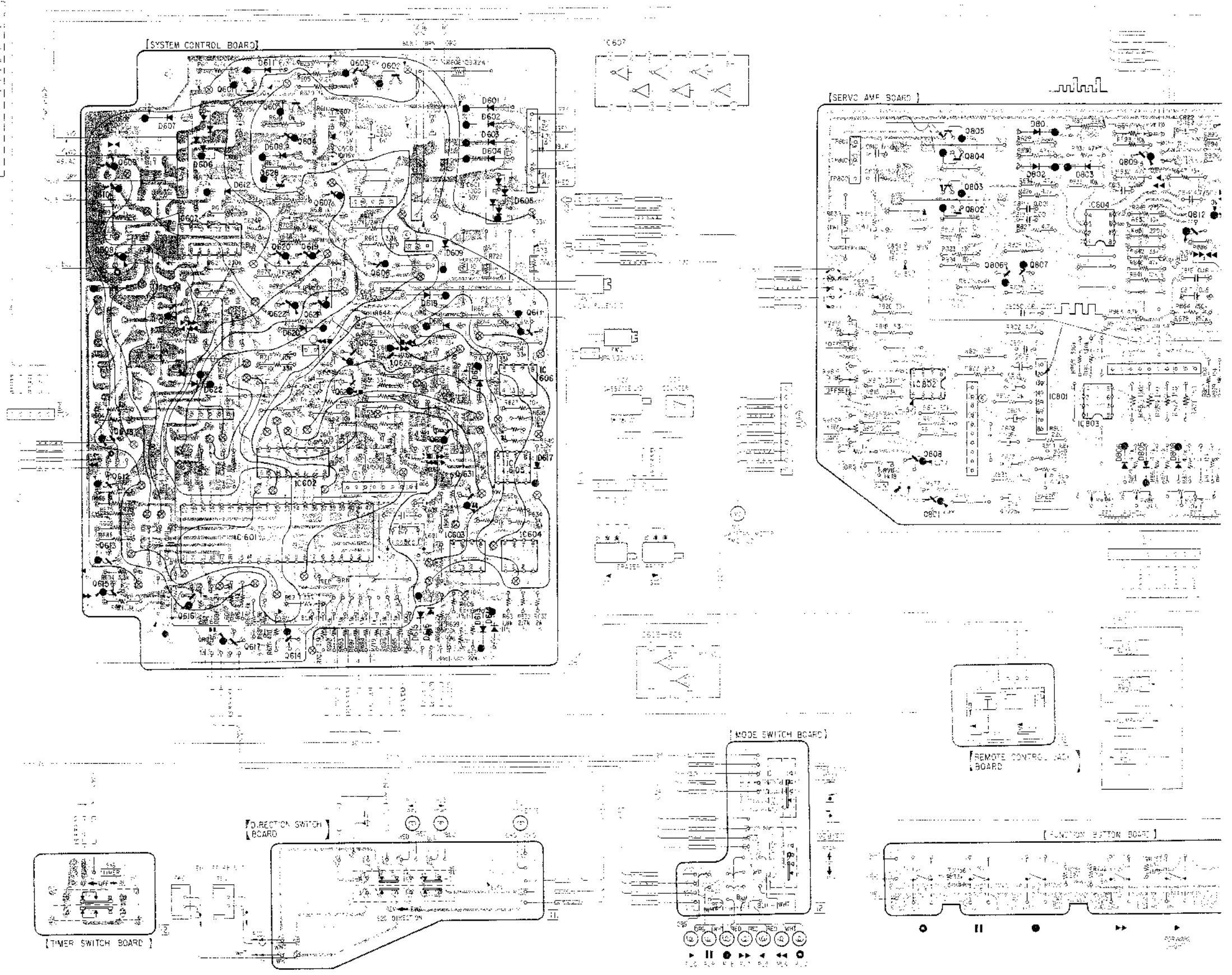
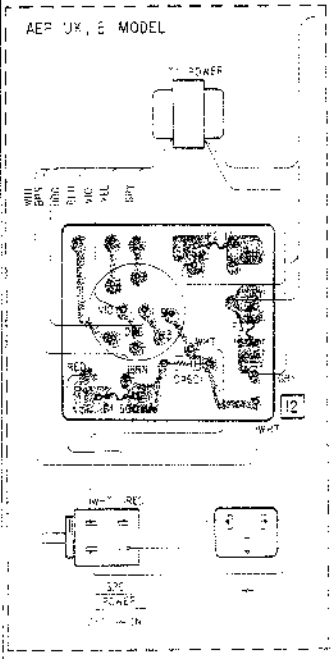
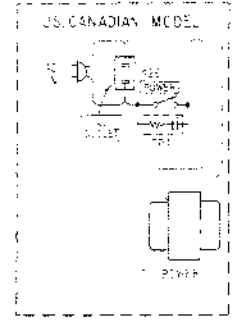

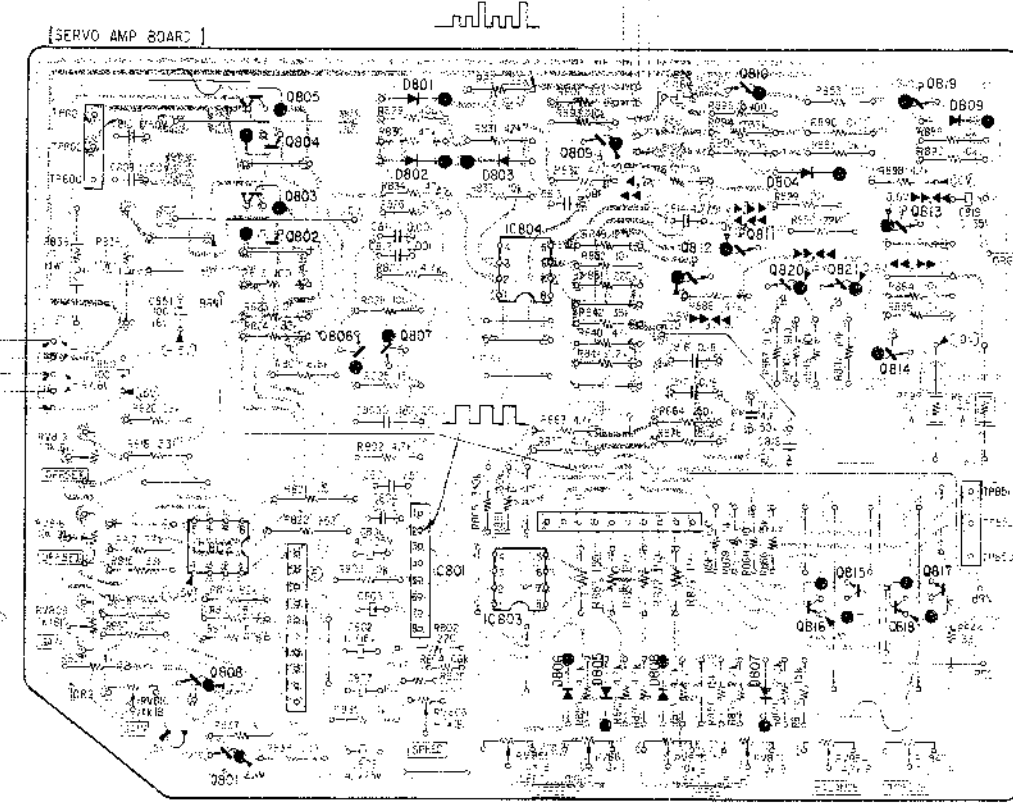
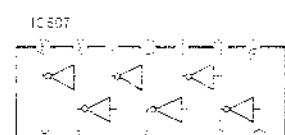
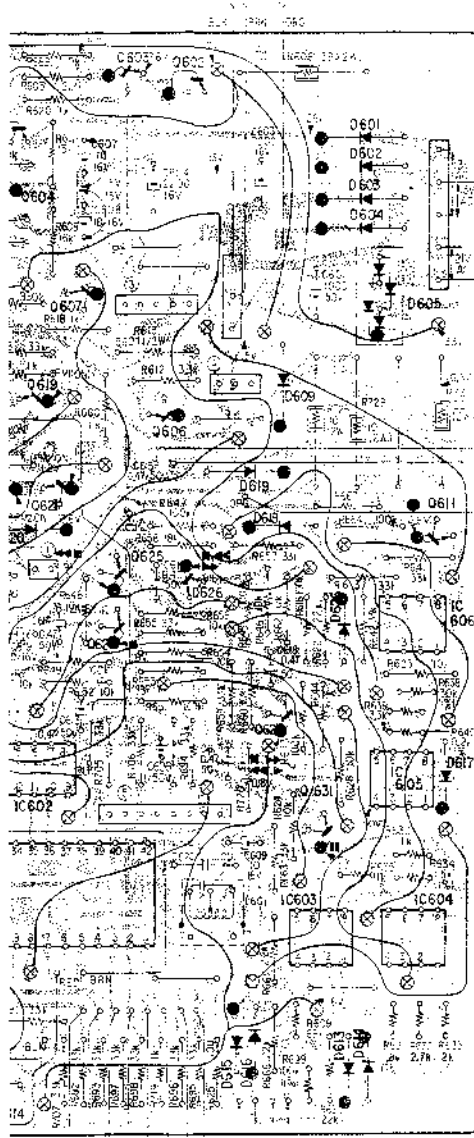

Q, IC	Q
810	80
805, 89	809
805	809
804	802, 803, 804
802	
602	613
812	E
820, 82	
IC504	
806, 807	F14
C802	
C803	
815, 87	
816, 88	
806	806, 808, 809, 807
80	

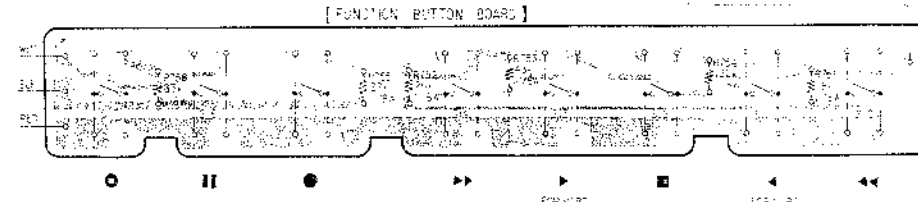
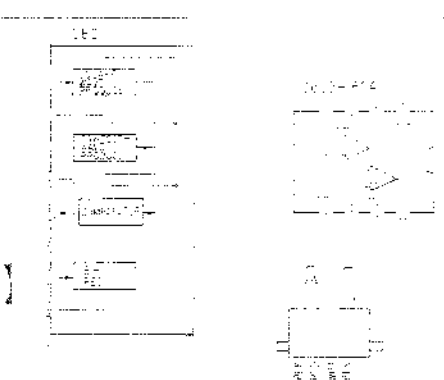
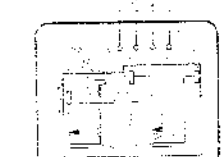
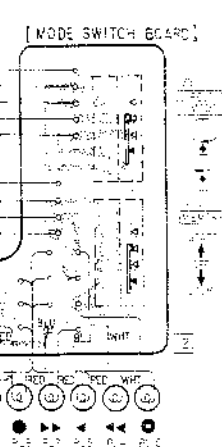
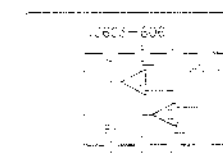
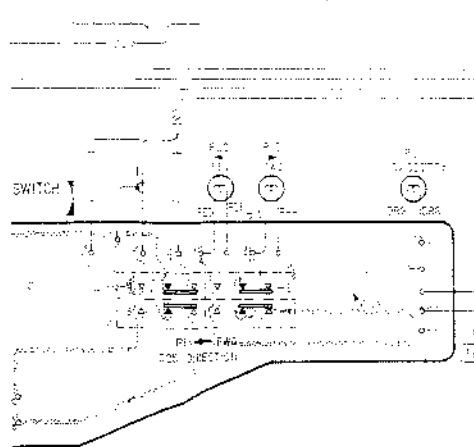

Replacement Semiconductors: See page 22.

A. Component side being over the top of the board.

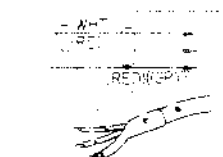

- : parts extracted from the component side
- : parts extracted from the conductor side.
- ⊙ : Through hole.
- ⊗ : components of pattern
- ⊕ : B + (high) pattern
- ⊖ : B - pattern

A

4-4. MOUNTING DIAGRAM -Audio Amp Section-

-Conductor Side-

• Replacement Semiconductors: See Page 35.

• Color code of sleeving over the end of the jacket.



— parts extracted from the component side.

• parts extracted from the conductor side.

• Signal Path

— L-CH

— R-CH

— B + (high) pattern

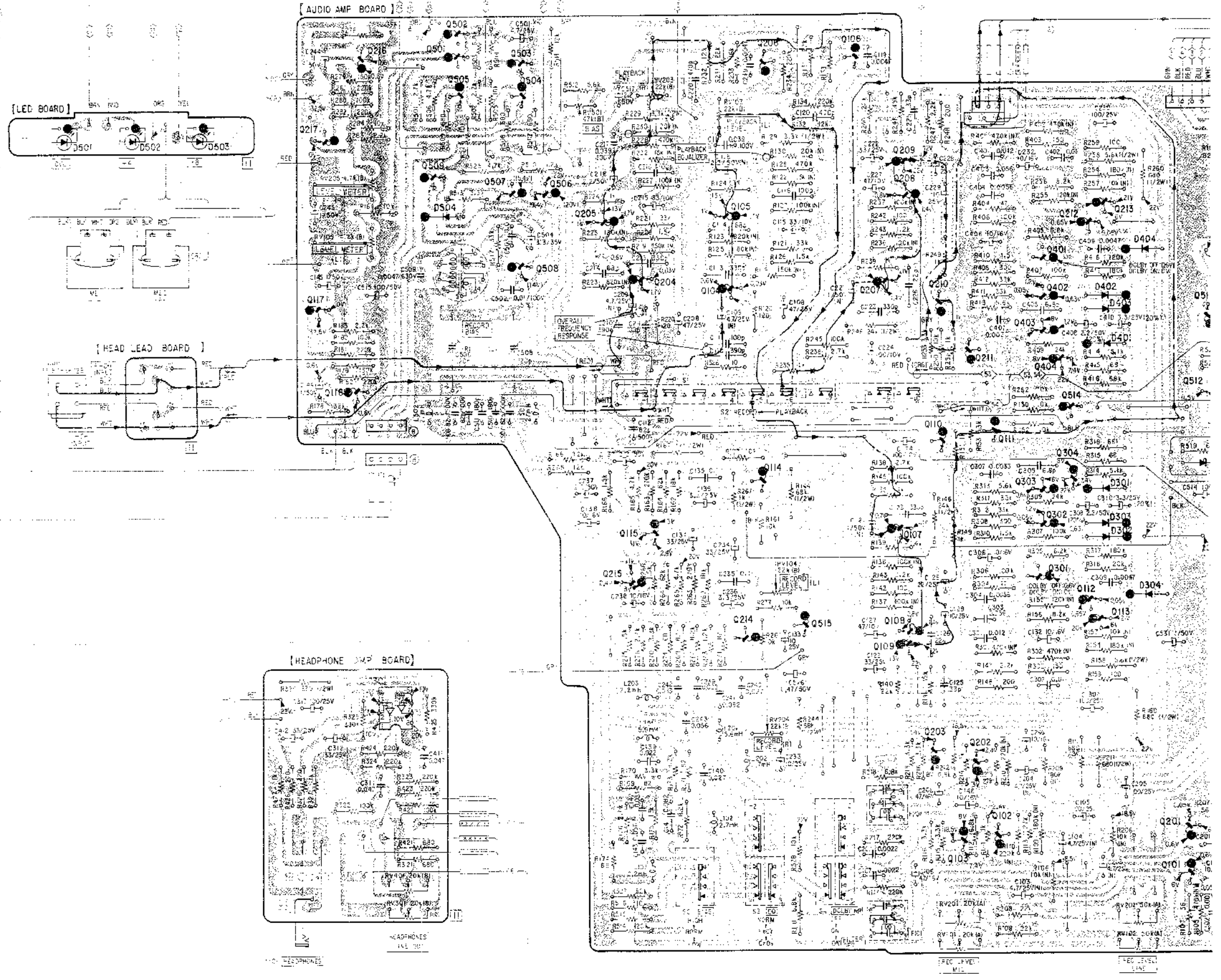

B

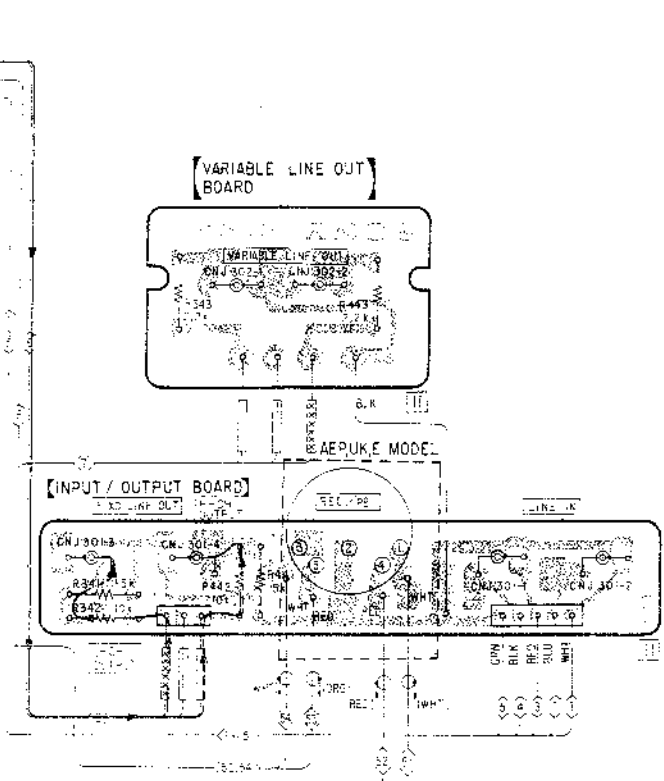
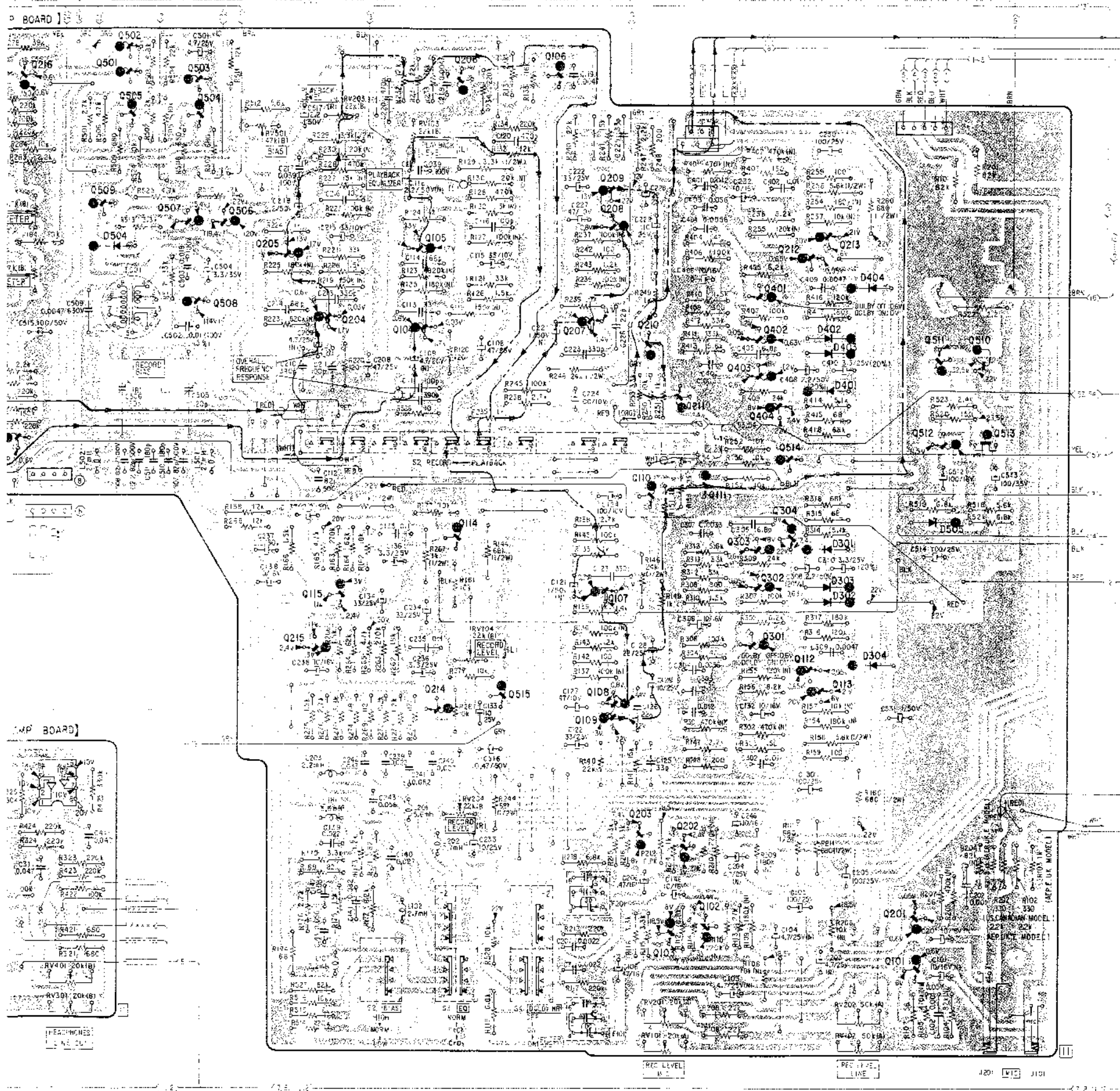



Q, IC	D
502	
216	501, 206
503	
505, 504	
217	501, 503
509	209
507, 506	
208	
105, 213	504
205	212
40:	404
506	
204, 207	402
104, 402	403
17	511, 510
403	
21	40:
404	
116	512, 513
514	
111	
110	
	505
4	304
303	30:
302	302
115	107
302	302
2.5	301
112	
515	113
108	
106	
102	
203	
202	
102	201
103	
101	
Q, IC	D

Note: The components identified by shading and mark  are critical for safety. Replace only with part number specified.

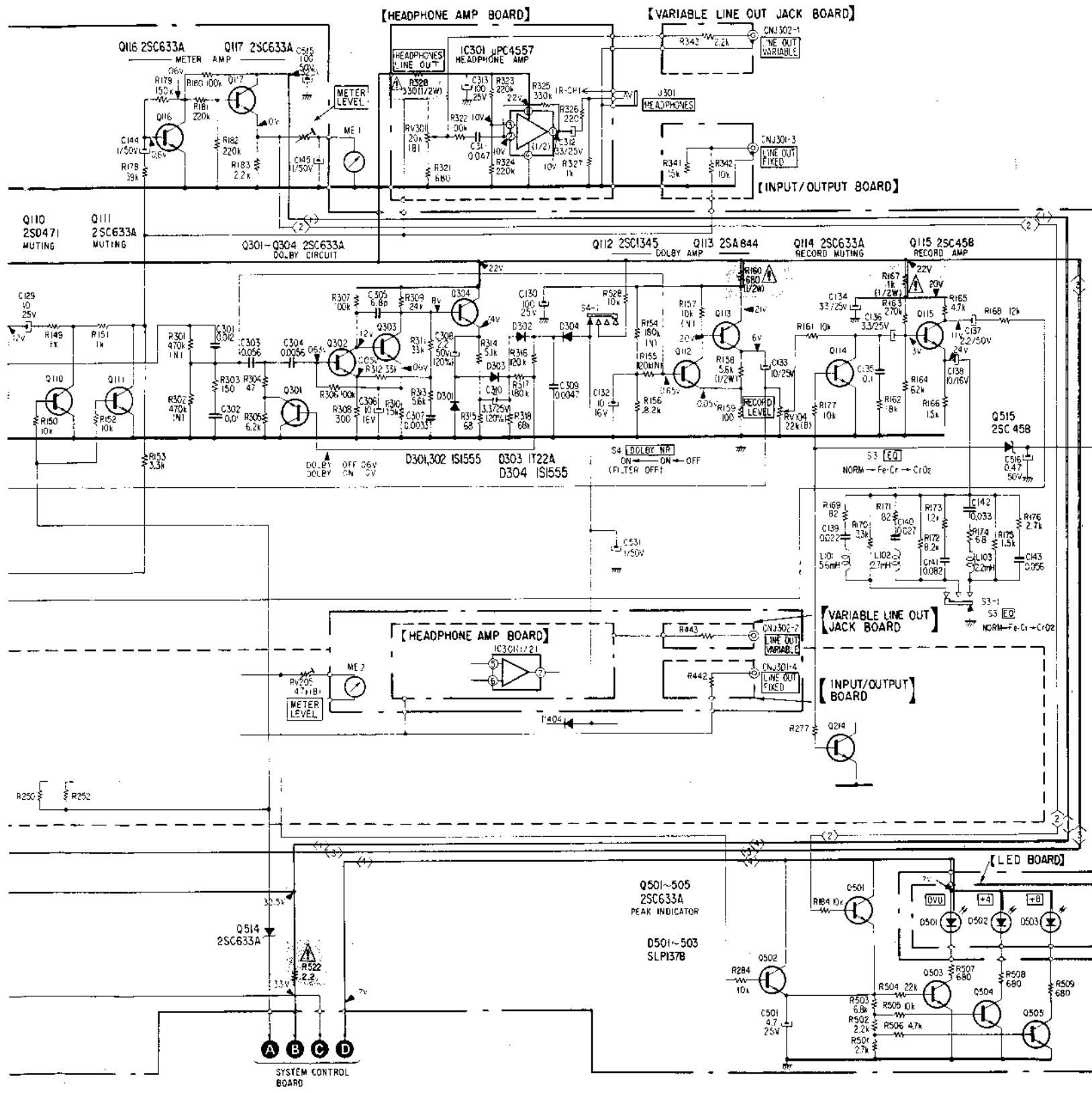
Note: Les composants identifiés par un trame et une marque  sont critiques pour la sécurité. Ne les remplacer que par une pièce portant le numéro spécifié.



- All capacitors are in μF unless otherwise noted. $\text{pF} = \mu\text{F} / 100$. 50 WV or less are not indicated except for electrolytics.
- All resistors are in ohms, $\frac{1}{4}\text{W}$ unless otherwise noted. $\text{k}\Omega = 1000\Omega$, $\text{M}\Omega = 1000 \text{k}\Omega$.
- (N) : low-noise resistor.
- $\text{B}+$: B + bus.
-  : panel designation.
-  : adjustment for repair.
- Voltages are dc with respect to ground unless otherwise noted.
- Readings are taken under no signal conditions with a VOM (20 $\text{k}\Omega/\text{V}$).
- () : record
- no mark: stop
- Voltage variations may be noted due to normal production tolerances.
- Switch

Ref. No.	Switch	Position
S1	RECORD/PLAYBACK	PLAYBACK
S2	BIAS	HIGH
S3	EQ	NORM
S4	DOLBY NR	OFF

• Replacement Semiconductors

For replacement, use semiconductors except in () .

Q101-105, 107 Q201-205, 207 Q112, 212	Q510 : 2SC1173
Q106, 206, 116, 216 Q111, 211, 117, 217 Q114, 214, 501-507 Q509, 514 Q301-304 Q401-404	Q513 : 2SK30A
Q108, 109, 115 Q208, 209, 215 Q511, 512, 515	IC301 : $\mu\text{PC4557C}$ (μPC4557)
Q113, 213 : 2SA678 (2SA844)	D301, 302, 304 D401, 402, 404 1S1556 D504 D303, 403 : 1T22AM (1T22A)
Q110, 210 : 2SC1474 (2SD471)	D501-503 : SLP137B
Q508 : 2SC1475 (2SC1318)	Q505 : E0B01-122 (EQ401-129)

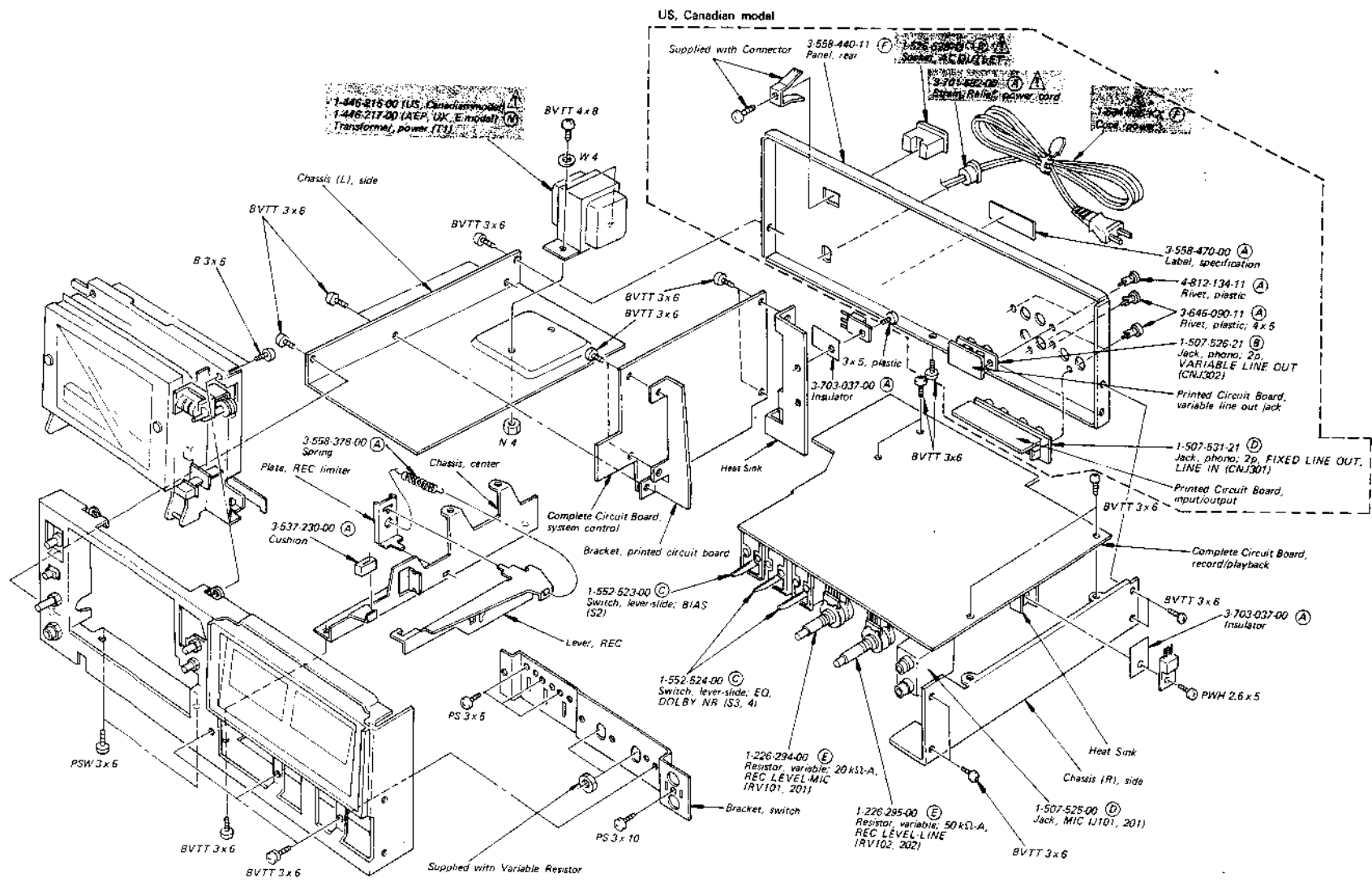

Note: The components identified by shading and mark  are critical for safety. Replace only with part number specified.

Note: Les composants identifiés par un trame et une marque  sont critiques pour la sécurité. Ne les remplacer que par une pièce portant le numéro spécifié.

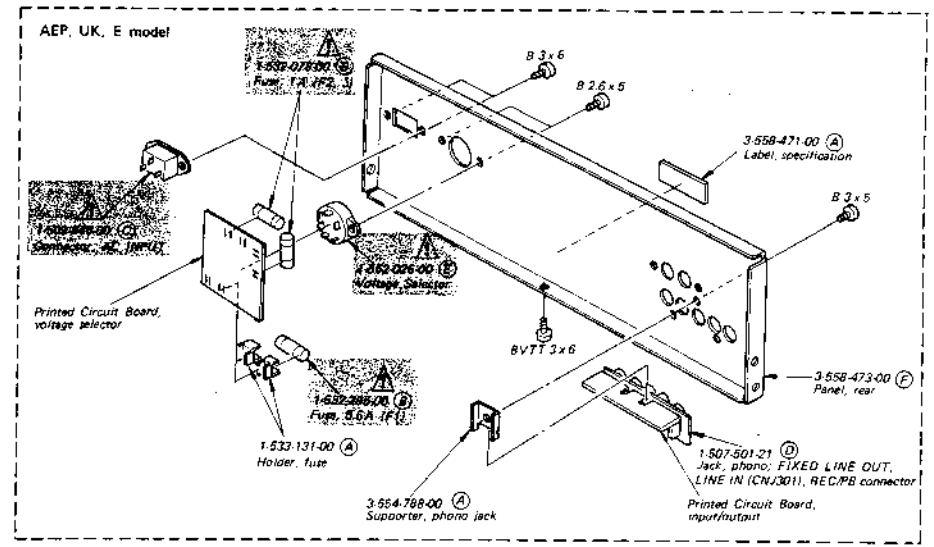

Note:

- Items with no part number and/or no description are not stocked because they are seldom required for routine service.
- All screws are Phillips (cross recess) type unless otherwise noted.
- (-) = slotted head
- Circled letters (A) to (Z) are applicable to European models only

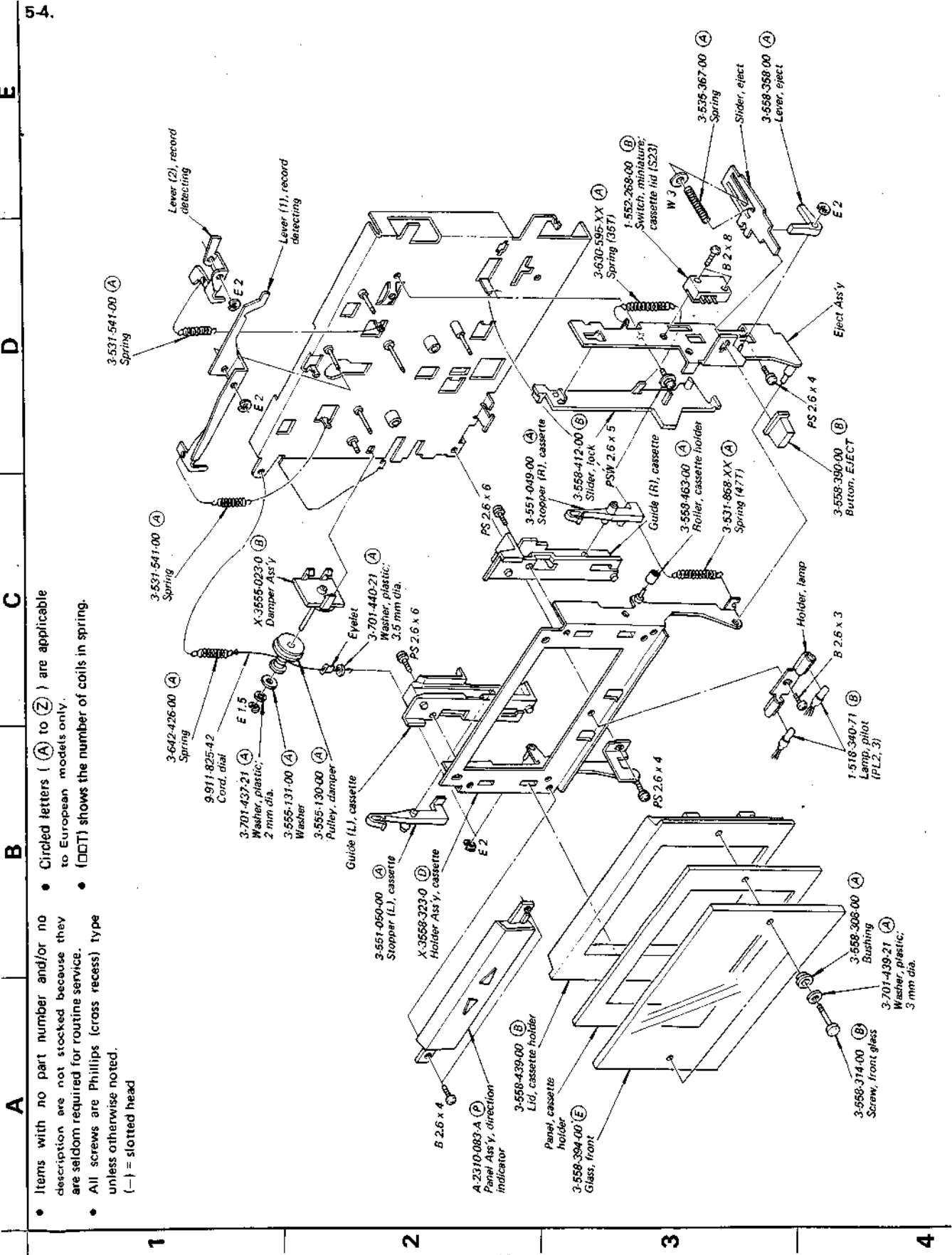

- Items with no part number and/or no description are not stocked because they are seldom required for routine service.
- All screws are Phillips (cross recess) type unless otherwise noted.
- (-) = slotted head
- Circled letters (A) to (Z) are applicable to European models only.
- (DOT) shows the number of coils in spring.

5-7.

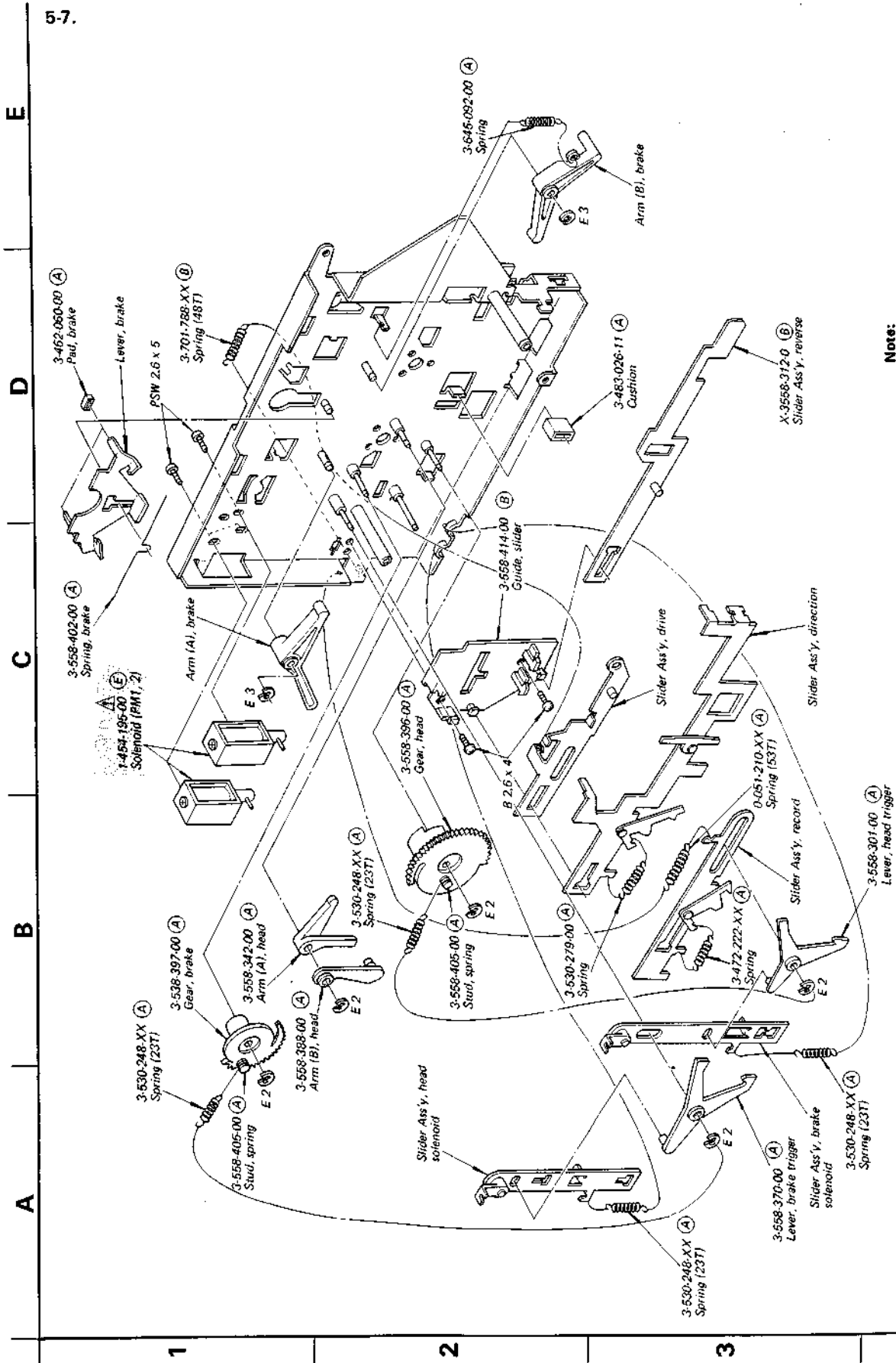

Note:

- Items with no part number and/or no description are not stocked because they are seldom required for routine service.
- All screws are Phillips (cross recess) type unless otherwise noted.
- (-) = slotted head
- Circled letters (A) to (Z) are applicable to European models only.
- (nT) shows the number of coils in spring.

Note: Les composants identifiés par un trame et une marque **A** sont critiques pour la sécurité. Ne les remplacer que par une pièce portant le numéro spécifié.

Note: The components identified by shading and mark **A** are critical for safety. Replace only with part number specified.

IC-K96R

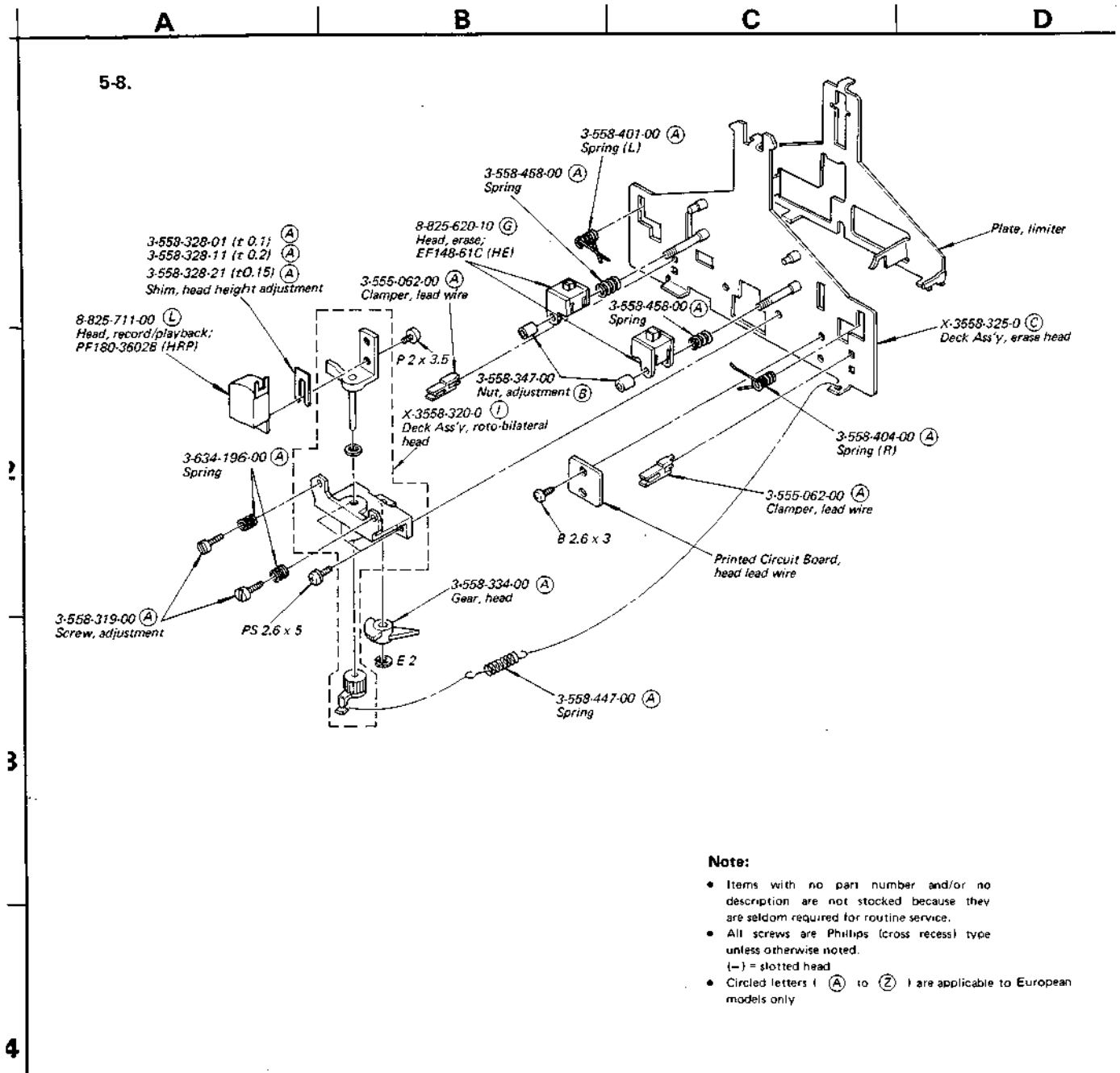

SECTION 6 ELECTRICAL PART LIST

• Circled letters (A) to (Z) are applicable to European models only.

<u>Ref. No.</u>	<u>Part No.</u>	<u>Description</u>	<u>Ref. No.</u>	<u>Part No.</u>	<u>Description</u>
PRINTED CIRCUIT BOARD .					
	1-588-144-00	(B) Voltage Selector (AEP, UK, E model)	⇒ Q801	8-729-663-47	(B) 2SC1364
SEMICONDUCTORS					
Transistors					
Q101-105)	8-729-334-58	(B) 2SC1345	Q802	8-729-141-43	(B) 2SD414
Q201-205)			Q803, 804	8-729-154-83	(B) 2SB548
⇒ Q106, 206	8-729-663-47	(B) 2SC1364	Q805	8-729-141-43	(B) 2SD414
Q107, 207	8-729-334-58	(B) 2SC1345	⇒ Q806-813	8-729-663-47	(B) 2SC1364
⇒ Q108, 208)	8-729-663-47	(B) 2SC1364	⇒ Q814	8-727-788-00	(B) 2SA678
Q109, 209)			Q815	8-729-141-43	(B) 2SD414
⇒ Q110, 210	8-760-335-10	(B) 2SC1474	Q816, 817	8-729-154-83	(B) 2SB548
⇒ Q111, 211	8-729-663-47	(B) 2SC1364	Q818	8-729-141-43	(B) 2SD414
Q112, 212	8-729-334-58	(B) 2SC1345	⇒ Q819	8-727-788-00	(B) 2SA678
⇒ Q113, 213	8-727-788-00	(B) 2SA678	⇒ Q820, 821	8-729-663-47	(B) 2SC1364
⇒ Q114-117)	8-729-663-47	(B) 2SC1364	ICs		
Q214-217)			⇒ IC301	8-759-145-57	(C) μPC4557C
⇒ Q301-304)	8-729-663-47	(B) 2SC1364	IC601	8-759-147-22	(L) μPD547-022
Q401-404)			IC602	8-759-240-19	(C) TC4019P
⇒ Q501-507	8-729-663-47	(B) 2SC1364	⇒ IC603-606	8-759-145-57	(C) μPC4557C
⇒ Q508	8-760-413-10	(C) 2SC1475	IC607	8-759-940-69	(D) MSM4069
⇒ Q509	8-729-663-47	(B) 2SC1364	IC801	8-759-600-65	(F) CX065A
Q510	8-729-217-33	(C) 2SC1173	⇒ IC802-804	8-759-145-58	(D) μPC4558C
⇒ Q511, 512	8-729-663-47	(B) 2SC1364	Diodes		
Q513	8-729-203-04	(B) 2SK30A	D301, 401)	8-719-815-55	(B) 1S1555
⇒ Q514, 515	8-729-663-47	(B) 2SC1364	D302, 402)		
Q601	8-729-217-33	(C) 2SC1173	⇒ D303, 403	8-719-422-21	(B) 1T22AM
⇒ Q602	8-729-316-12	(D) 2SC1061	D304, 404	8-719-815-55	(B) 1S1555
⇒ Q603	8-729-663-47	(B) 2SC1364	D501-503	8-719-901-37	(B) SLP137B
Q604	8-727-788-00	(B) 2SA678	D504	8-719-815-55	(B) 1S1555
Q605, 606	8-729-160-51	(B) 2SB605	⇒ D505	8-719-930-12	(B) EQB01-12Z
⇒ Q607-619	8-729-663-47	(B) 2SC1364	D601-604	8-719-200-02	(B) 10E2
Q620	8-729-157-11	(B) 2SD571	D605, 606	8-719-511-10	(C) SILV10
⇒ Q621	8-729-663-47	(B) 2SC1364	D607	8-719-200-02	(B) 10E2
Q622	8-729-157-11	(B) 2SD571	⇒ D608	8-719-931-15	(B) EQB01-15
⇒ Q624-627	8-729-663-47	(B) 2SC1364	D609	8-719-200-02	(B) 10E2
Q628	8-729-157-11	(B) 2SD571	⇒ D611	8-719-930-11	(B) EQB01-11Z
⇒ Q629, 631	8-729-663-47	(B) 2SC1364	D612-618	8-719-815-55	(B) 1S1555
• ⇒ : Due to standardization, interchangeable replacements may be substituted for parts specified in the diagrams.					

Note: The components identified by shading and mark  are critical for safety. Replace only with part number specified.

Note: Les composants identifiés par un trame et une marque  sont critiques pour la sécurité. Ne les remplacer que par une pièce portant le numéro spécifié.

• Circled letters (A) to (Z) are applicable to European models only.

<u>Ref. No.</u>	<u>Part No.</u>	<u>Description</u>
COILS		
L101, 201	1-407-203-XX	(A) 5.6 mH, microinductor
L102, 202	1-407-199-XX	(B) 2.7 mH, microinductor
L103, 203	1-407-198-XX	(A) 2.2 mH, microinductor
L501, 502	1-407-211-XX	(B) 27 μ H, microinductor
L601	1-405-800-00	(B) Osc
TRANSFORMERS		
T1	(A) 1-446-216-00	Power (US, Canadian model)
	(A) 1-446-217-00	(N) Power (AEP, UK, E model)
T501	1-433-132-11	(B) Bias Osc
CAPACITORS		
All capacitors are in μ F and ceramic unless otherwise noted. 50WV or less are not indicated except for electrolytics. pF = μ μ F, elect = electrolytic		
C101, 201	1-121-651-11	(A) 10 16V elect
C102, 202	1-161-323-11	(A) 0.001
C103, 203 C104, 204	1-121-915-11	(B) 4.7 25V elect
C105, 205	1-121-416-11	(B) 100 25V elect
C106, 206	1-121-409-11	(A) 47 16V elect
C107, 207	1-108-230-12	(A) 0.0022 mylar
C108, 208	1-121-410-11	(B) 47 25V elect
C109, 209	1-121-915-11	(B) 4.7 25V elect
C110, 210	1-161-318-11	(A) 390p
C111, 211	1-161-271-11	(A) 100p
C112, 212	1-107-037-11	(A) 82p 500V silvered mica
C113, 213	1-161-317-11	(A) 330p
C114, 214	1-161-269-11	(A) 68p
C115, 215	1-121-402-11	(A) 33 10V elect
C116, 216	1-161-271-11	(A) 100p
C117, 217	1-130-190-11	(B) 0.039 100V polyethylene
C118, 218	1-121-450-11	(A) 2.2 50V elect
C119, 219	1-108-234-12	(A) 0.0047 mylar
C120, 220	1-161-319-11	(A) 470p
C121, 221	1-121-391-11	(A) 1 50V elect

<u>Ref. No.</u>	<u>Part No.</u>	<u>Description</u>
C122, 222	1-121-404-11	(A) 33 25V elect
C123, 223	1-161-317-11	(A) 330p
C124, 224	1-121-414-11	(A) 100 10V elect
C125, 225	1-161-265-11	(A) 33p
C126, 226	1-161-263-11	(A) 22p
C127, 227	1-121-352-11	(A) 47 10V elect
C128, 228	1-121-480-11	(A) 22 25V elect
C129, 229	1-121-398-11	(A) 10 25V elect
C130, 230	1-121-416-11	(B) 100 25V elect
C131	1-121-391-11	(A) 1 50V elect
C132, 232	1-121-651-11	(A) 10 16V elect
C133, 233	1-121-398-11	(A) 10 25V elect
C134, 234	1-121-404-11	(A) 33 25V elect
C135, 235	1-108-251-12	(B) 0.1 mylar
C136, 236	1-121-392-11	(A) 3.3 25V elect
C137, 237	1-121-450-11	(A) 2.2 50V elect
C138, 238	1-121-651-11	(A) 10 16V elect
C139, 239	1-108-242-12	(A) 0.022 mylar
C140, 240	1-108-589-12	(A) 0.027 mylar
C141, 241	1-108-362-12	(B) 0.082 mylar
C142, 242	1-108-591-12	(A) 0.033 mylar
C143, 243	1-108-361-12	(A) 0.056 mylar
C144, 244 C145, 245	1-121-391-11	(A) 1 50V elect
C146, 246	1-121-651-00	(A) 10 16V elect
C301, 401	1-108-581-12	(A) 0.012 mylar
C302, 402	1-108-239-12	(A) 0.01 mylar
C303, 403	1-108-361-12	(A) 0.056 mylar
C304, 404	1-108-355-12	(A) 0.0056 mylar
C305, 405	1-161-257-11	(A) 6.8p
C306, 406	1-121-651-11	(A) 10 16V elect
C307, 407	1-108-567-12	(A) 0.0033 mylar
C308, 408	1-121-450-11	(A) 2.2 50V elect
C309, 409	1-108-234-12	(A) 0.0047 mylar
C310, 410	1-121-392-11	(A) 3.3 25V elect

Note: The components identified by shading and mark  are critical for safety. Replace only with part number specified.

Note: Les composants identifiés par un tramé et une marque  sont critiques pour la sécurité. Ne les remplacer que par une pièce portant le numéro spécifié.

TC-K96R

• Circled letters (A to Z) are applicable to European models only.

Ref. No.	Part No.	Description
C311, 411	1-161-021-11	(A) 0.047 (semiconductor)
C312, 412	1-121-404-11	(A) 33 25V elect
C313	1-121-416-11	(B) 100 25V elect
C501	1-121-395-11	(A) 4.7 25V elect
C502	1-129-701-11	(A) 0.01 100V polyethylene
C503	1-130-189-11	(B) 0.018 100V polyethylene
C504	1-131-350-11	(B) 3.3 35V tantalum
C505,506	1-141-010-XX	(B) Trimmer, 120p
C507,508	1-107-037-11	(A) 82p 500V mica
C509	1-129-710-11	(B) 0.0047 630V polyethylene
C510,511	1-107-091-11	(A) 180p mica
C512	1-121-415-11	(A) 100 16V elect
C513	1-121-357-11	(B) 100 35V elect
C514	1-121-416-11	(B) 100 25V elect
C515	1-121-417-11	(B) 100 50V elect
C516	1-121-726-11	(A) 0.47 50V elect
C517	1-121-450-11	(A) 2.2 50V elect
C601	(A) 1-123-364-11	(C) 1000 50V elect
C602	(A) 1-123-361-11	(B) 220 50V elect
C603,604	(A) 1-123-325-11	(B) 2200 16V elect
C605,606	(A) 1-123-334-11	(B) 220 25V elect
C607-610	1-121-651-11	(A) 10 16V elect
C611,612	1-121-395-11	(A) 4.7 25V elect
C613-618	1-121-726-11	(A) 0.47 50V elect
C619	1-121-651-11	(A) 10 16V elect
C620	1-161-323-11	(A) 0.001
C621	1-161-379-11	(A) 0.01
C622-624	1-121-651-11	(A) 10 16V elect
C625	1-121-395-11	(A) 4.7 25V elect
C801	1-123-228-11	(B) 1 50V elect (nonpolarized)
C802,803	1-121-651-11	(A) 10 16V elect
C804	1-108-240-12	(A) 0.015 mylar
C805	1-130-134-00	(B) 0.082 100V laminated
C806	1-121-395-11	(A) 4.7 25V elect
C807	1-121-450-11	(A) 2.2 50V elect
C808	1-121-395-11	(A) 4.7 25V elect
C809,810	1-123-228-11	(B) 1 50V elect (nonpolarized)

Ref. No.	Part No.	Description
C811-813	1-161-323-11	(A) 0.001
C814,815	1-123-232-11	(B) 4.7 50V elect (nonpolarized)
C816,817	1-108-364-12	(A) 0.18 mylar
C818	1-123-232-11	(B) 4.7 50V elect (nonpolarized)
C819	1-121-738-11	(A) 10 50V elect
C822	1-121-651-11	(A) 10 16V elect
C850,851	1-121-415-11	(A) 100 16V elect

RESISTORS

All resistors are in ohms. Common 1/4W carbon resistors are omitted. Check schematic diagram for values.

R111,211	(A) 1-244-869-11	(A) 680 1/4W carbon
R129,229	1-244-885-11	(A) 3.3k 1/4W carbon
R144,244	1-244-917-11	(A) 68k 1/4W carbon
R146,246	1-244-906-11	(A) 24k 1/4W carbon
R158,258	1-244-891-11	(A) 5.6k 1/4W carbon
R160,260	(A) 1-244-869-11	(A) 680 1/4W carbon
R167,267	(A) 1-244-873-11	(A) 1k 1/4W carbon
R328	(A) 1-244-861-11	(A) 330 1/4W carbon
R522	(A) 1-246-409-11	(A) 2.2 1/4W carbon
R602	(A) 1-244-889-11	(A) 4.7k 1/4W carbon
R606	(A) 1-206-477-11	(A) 39 2W metal oxide (nonflammable)
R609	1-214-176-11	(A) 68k 1/4W metal oxide (1%)
R613	(A) 1-244-867-11	(A) 560 1/4W carbon
R629	1-214-180-11	(A) 100k 1/4W metal oxide (1%)
R631	1-214-138-11	(A) 1.8k 1/4W metal oxide (1%)
R632	1-214-142-11	(A) 2.7k 1/4W metal oxide (1%)
R633	1-214-139-11	(A) 2k 1/4W metal oxide (1%)
R634	1-214-136-11	(A) 1.5k 1/4W metal oxide (1%)
R635,636	1-214-132-11	(A) 1k 1/4W metal oxide (1%)
R638	1-214-167-11	(A) 30k 1/4W metal oxide (1%)
R639	1-214-144-11	(A) 3.3k 1/4W metal oxide (1%)
R640	1-214-154-11	(A) 8.2k 1/4W metal oxide (1%)
R728,729	(A) 1-206-463-11	(A) 10 2W metal oxide (nonflammable)

Note: The components identified by shading and mark **A** are critical for safety. Replace only with part number specified.

Note: Les composants identifiés par un trame et une marque **A** sont critiques pour la sécurité. Ne les remplacer que par une pièce portant le numéro spécifié.

• Circled letters (A) to (Z) are applicable to European models only.

Ref. No.	Part No.	Description
R731	△ 1-206-471-11	(A) 22 2W metal-oxide (nonflammable)
R751	1-210-113-11	(A) 18k 1/8 W carbon
R752	1-246-859-11	(A) 20k 1/8 W carbon
R753	1-246-863-11	(A) 43k 1/8 W carbon
R754	1-246-869-11	(A) 130k 1/8 W carbon
R755	1-210-114-11	(A) 22k 1/8 W carbon
R756	1-210-381-11	(B) 33k 1/8 W carbon
R804	1-214-176-11	(A) 68k 1/4 W metal oxide
R805	1-214-180-00	(A) 100k 1/4 W metal oxide
R838,839	△ 1-213-036-11	(A) 1 1W fusible
R891,892	△ 1-212-393-11	(A) 4.7 1W metal oxide (nonflammable)

RV101,201	1-226-294-00	(E) 20k-A, variable; MIC
RV102,202	1-226-295-00	(E) 50k-A, variable; LINE
RV103,203	1-224-646-XX	(B) 22k-B, adjustable; playback level, record level
RV104,204		
RV105,205	1-224-644-XX	(B) 4.7k-B, adjustable; level meter
RV301,401	1-226-131-00	(E) 20k-B, variable; HEADPHONES LINE OUT
RV501	1-224-647-XX	(B) 47k-B, adjustable; bias
RV806	1-224-661-00	(B) 47k-B, adjustable; speed
RV809,810	1-224-642-XX	(B) 1k-B, adjustable; gain
RV816,819	1-224-645-XX	(B) 10k-B, adjustable; offset
RV843	1-224-642-XX	(B) 1k-B, adjustable; torque
RV854	1-224-633-00	(B) 4.7k-B, adjustable; balance

SWITCHES

S1	1-552-521-00	(C) slide, record/playback
S2	1-552-523-00	(C) Lever-slide, BIAS
S3,4	1-552-524-00	(C) Lever-slide, EQ, DOLBY NR
S10-17	1-552-540-00	(B) pushbutton, function

Ref. No.	Part No.	Description
S18	1-552-520-00	(C) Slide, TIMER
S19,20	1-552-522-00	(C) Rotary, MEMORY, DIRECTION MODE
S21-23	1-552-268-00	(B) Miniature, eraser proof, cassette lid
S24	1-548-526-00	(G) Tape Counter, w/switch
S25	1-516-686-00	(C) Slide, direction
S26	△ 1-552-610-00	Rotary, POWER (US, Canadian model)
S26	△ 1-552-611-00	(D) Rotary, POWER (AEP, UK, E model)

MISCELLANEOUS

CNJ301	1-507-501-21	(D) Jack, phono; 4p, LINE IN, LINE OUT-FIXED (AEP, UK, E model)
	1-507-531-21	Jack, phono; 4p, LINE IN, LINE OUT-FIXED (US, Canadian model)
CNJ302	1-507-526-21	(B) Jack, phono; 2p, LINE OUT-VARIABLE
CP1	1-231-326-00	Encapsulated Component (US model)
	△ 1-231-341-00	Encapsulated Component (Canadian model)
CP601	△ 1-231-057-00	(B) Encapsulated Component (AEP, UK, E model)
F1	△ 1-532-295-00	(B) Fuse, 0.5A (AEP, UK, E model)
F2,3	△ 1-532-078-00	(B) Fuse, 1A (AEP, UK, E model)
F101,201	1-231-388-00	(C) Low-pass Filter
HE	8-825-620-10	(G) Head, erase; EF148-61C
HRP	8-825-711-00	(L) Head, record/playback; PF180-3602B
J6	1-507-591-00	(C) Jack, remote control
J101,201	1-507-525-00	(D) Jack, MIC
J301	1-507-553-00	(C) Jack, HEADPHONES
M1	X-3558-341-1	(M) Motor, reel
M2	X-3558-340-1	(M) Motor, capstan
ME1, 2	1-520-352-00	(J) Meter, level
P1	1-506-385-00	(D) Plug, remote control
PL1-10	1-518-340-71	(B) Lamp, pilot
PM1, 2	△ 1-454-195-00	(E) Solenoid

Note: The components identified by shading and mark △ are critical for safety. Replace only with part number specified.

Note: Les composants identifiés par un trame et une marque △ sont critiques pour la sécurité. Ne les remplacer que par une pièce portant le numéro spécifié.

IC-K96R

- Circled letters (**A**) to (**Z**) are applicable to European models only.

<u>Part No.</u>	<u>Description</u>
1-452-155-00	(B) Magnet
△ 1-509-546-00	(C) Connector, AC INPUT (AEP, UK, E model)
△ 1-526-528-00	Socket, AC OUTLET (US, Canadian model)
△ 1-533-131-00	(A) Holder, fuse (AEP, UK, E model)
△ 1-534-986-XX	Cord, power (US, Canadian model)
△ 1-552-026-00	(E) Voltage Selector (AEP, UK, E model)

ACCESSORIES AND PACKING MATERIALS	
<u>Part No.</u>	<u>Description</u>
X-3701-105-0	(A) Tips Ass'y, head cleaning
1-534-049-31	(E) Cord, connection; RK-74H
△ 1-534-754-00	Cord, power, parallel-blade plug (E model)
△ 1-534-819-00	(E) Cord, power (UK model)
△ 1-551-216-00	Cord, power, euro plug (E model)
1-551-576-00	(I) Cord, remote control
3-429-126-00	(B) Bag, plastic; set
3-558-465-00	(B) Cushion (AEP, UK, E model)
3-558-474-00	(A) Spacer
3-558-475-00	Carton (US, Canadian model)
3-558-476-00	(D) Carton (AEP, UK, E model)
3-558-478-00	Cushion (US, Canadian model)
3-701-630-00	(A) Bag, plastic
3-770-549-11	(G) Manual, instruction (AEP, UK, E model)
3-770-549-21	Manual, instruction (US model)
3-770-549-21	Manual, instruction (Canadian model)
3-794-316-31	
3-794-233-21	(A) Leaflet

Note: The components identified by shading and mark **△** are critical for safety. Replace only with part number specified.

Note: Les composants identifiés par un trame et une marque **△** sont critiques pour la sécurité. Ne les remplacer que par une pièce portant le numéro spécifié.

9-954-662-11
(With-81, -83)

Sony Corporation
Consumer Products Group
Technical Support Dept.

English
83D0205-5
Printed in Japan
© 1982

STEREO CASSETTE DECK

TC-K96R

*AEP Model
E Model
Canadian Model
UK Model
US Model*

No. 1
January, 1979

SUPPLEMENT

File this supplement with the service manual.

CIRCUIT DESCRIPTION

The system controller printed circuit board incorporates a micro computer.

The micro computer issued the drive signals for the solenoid, the reel motor, the capstan motor, etc., upon receiving the appropriate input signals from the operation switches, and thus carries out the switching required for each mode.

A simple explanation of the micro computer operation follows:

1. Micro Computer

The micro computer, literally, means a microscopic electronic computer. However, a computer, being more than a calculator, has functions similar to those of the human brain.

The human brain has three major functions.

- 1) Storage a capacity to store (memorize) previously received information.
- 2) Decision the ability to compare information obtained from the sense functions (eye, hand, leg, etc.) with the memorized information and to put out the most suitable instruction.
- 3) Instruction the ability to transmit the decisions to the body (hand, leg, etc.) and make it operate in the required way.

In the computer, the decision making, processing, and instruction generation part is called the CPU (Central Processing Unit); the storage part is the ROM (Read Only Memory = memory for only reading) or RAM (Random Access Memory = read/write portion); and the body corresponds to the I/O (I/O Interface = input/output devices).

To give a comprehensive name to all these electric circuits and functions, we use the term "computer".

There are however the following differences between the human brain and a computer.

- (1) In the computer storage, matters once memorized will not be forgotten.
- (2) The computer cannot make decisions regarding any non-stored information.
- (3) In speed of processing or decision making, a computer is much faster.
- (4) The computer cannot store as much as the human brain.

1) CPU

The CPU is the most important part of a computer and assumes a central role. Considering the CPU as a digital circuit, by applying a signal "we want to read contents of an address" at the input, the requested contents are output in response to the instruction. In other words the CPU carries out the processing taking out a sequential processing program from the program into which the instructions were entered and decoding the instructions.

In this device, a 4-bit CPU is employed. The 4-bit CPU is more suitable for system control rather than that for computations.

SONY
SERVICE MANUAL

TC-K96R

The CPU configuration in this device consists of a PC (Program Counter), STACK, DP (Data Point), ACC (Accumulator), ALU (Arithmetic Logic Unit). Each of these will be described below.

(a) PC (Program Counter)

This is a register which stores the address of the contents of the ROM to be processed next, so that the execution sequence of the program will be correctly followed.

Each time after executing one instruction, this is increased by + 1.

(b) STACK

This is a register for storing aside the contents of the PC when a subroutine is called or during interrupts.

(c) DP (Data Point)

This is a register which specifies the address of RAM.

(d) ACC (Accumulator)

This is a register for storage of the operation results of ALU or as a temporary storage external to the CPU.

(e) ALU (Arithmetic Logic Unit)

This is the arithmetic logic operation unit, which has functions of binary addition, increment, decrement, exclusive OR, comparison, etc.

2) Memory (Storage device)

(a) ROM (Read Only Memory)

This memory is only for reading. The following are the features of ROM. (1) It is difficult to modify the stored contents because it is impossible to rewrite the contents of ROM by a program. (2) Even if the power source is cut off, the contents stored in a ROM will not be erased. Utilizing these features, the ROM stores the data which should not change. Further, when no data is needed, the power dissipation can be made lower by switching off the power source.

In this device a 1000 word x 8-bit mask ROM is employed for storing the program, etc., and is addressed by the PC.

The features of a mask ROM.

- (1) The chip size is smaller than that of a RAM.
- (2) It is suitable for storing considerable data of the same pattern.
- (3) It can be cheaper than a P-ROM in mass manufacture.

(b) RAM (Random Access Memory)

This is a memory in which data can be recorded or can be read out at any position in any sequence by specifying the address and the bit. In this microcomputer, data is stored in a 64 x 4-bit static RAM and is addressed by DP (Data Point).

The features of the static RAM.

- (1) The power dissipation per bit is high.
- (2) Operation speed is slow.
- (3) Because data does not get erased with time, refreshing is not needed.

2. Programming

A program is a description of the sequence of operations to be followed by the computer expressed in a language that the computer can comprehend, and which is based on the basic functions possessed by the computer.

The language which the computer can understand is called the "machine language". The machine language descriptions are those that the computer can decode immediately and execute, and are expressed with the combination of "0" and "1". However, the machine language can be different for different computers.

Because the machine language is very much different from the English language, it is translated into an assembler language, and is expressed with mnemonics (these express instruction words, with letters which function as a mnemonic aid).

Some examples of descriptions in the machine language and in the assembler language employed in this micro-computer are given below.

Machine Language	Assembler Language	Contents of Operation
1010 0000	CLA	ACC ← 0 (Contents of the accumulator are cleared)

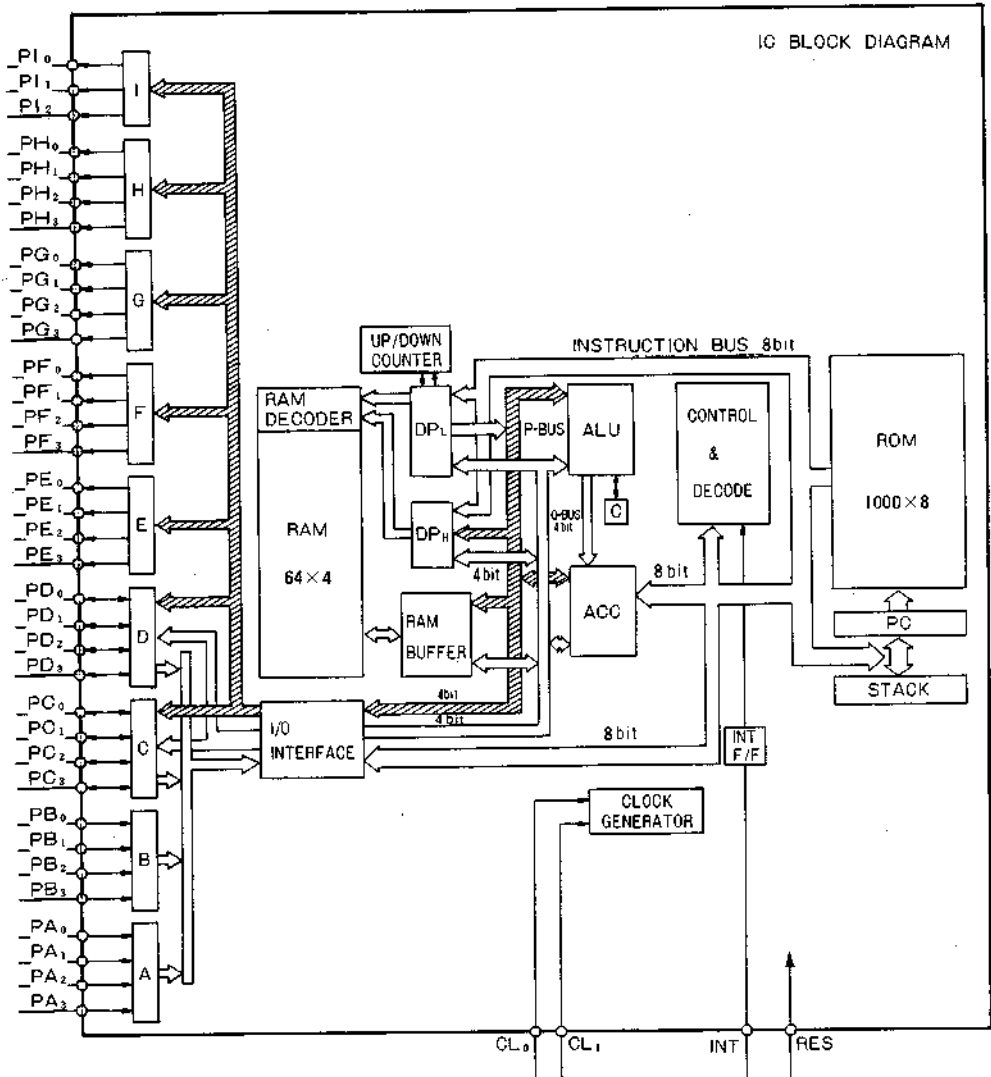

Fig. 1

3. Flow Chart

The flow chart expresses graphically the operating procedures and their functional implications.

The operations that we want the computer to do are written in accordance with the processing procedure.

(When a program is written, the flow-chart is very frequently written since the pictorial representation facilitates defining and arranging the problem.)

A part of the operations in this micro-computer will be explained by means of the flow chart and the program.

SYMBOLS USED

- ADDRESS Contents of PC
- OBJECT CODE . . . Machine Language (binary notation)
- DATA Machine Language (hexadecimal notation)
- INSTRUCTION . . . Assembler Language (mnemonic)
- () Contents of Register
- [(XX)] Contents of Memory Addressed by (X X)
- ← Transfer Direction, Result

FLOW CHART

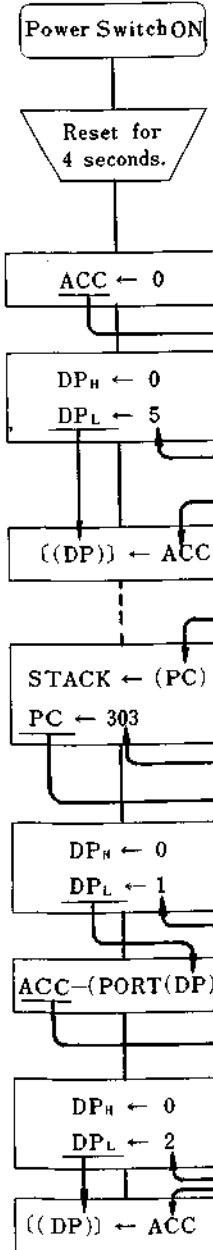

ADDRESS	OBJECT CODE	DATA	INSTRUCTION	COMMENT
000	10010000	90	CLA	Clear ACC.
001	10000101	85	LDZ	Clear DP _H . Load the immediate data in DP.
002	00000010	02	S	Store the contents of ACC in RAM addressed by DP.
00B	10101011	AB	CAL	Transfer the contents of PC to STACK.
00C	00000011	03		Load the immediate data in PC. (Sub-routine call)
303	10000001	81	LDZ	
304	00110010	32	IP	Load the input port in ACC addressed by DP.
305	10000010	82	LDZ	
306	00000010	02	S	

Fig. 2

4. Specifications of IC μ PD547-022

- P channel MOS, one chip microcomputer for control
- 42 pin plastic DIP
- 58 instructions
- ROM 1,000 x 8 bit
- RAM 64 x 4 bit
- Instruction circle: 10μ sec (clock = 400 kHz)

5. Calculation

1) Addition

$$\begin{array}{r} 0010 \dots (2) \\ + 0101 \dots (5) \\ \hline 0111 \dots (7) \end{array}$$

2) Subtraction

$$\begin{array}{r} 1001 \dots (9) \quad 1111 \\ - 0101 \dots (5) \Rightarrow -0101 \dots (5) \\ \hline 0100 \dots (4) \quad 1010 \\ + 1 \\ \hline 1011 \dots (\text{Complement}) \end{array}$$

↓

$$\begin{array}{r} 1001 \dots (9) \\ + 1011 \dots (\text{Complement of 5}) \\ \hline 1 \ 0100 \dots (4) \\ \hline \text{Disregard} \end{array}$$

3) Increment and carry

$$\begin{array}{r} 1111 \\ + 1 \dots (\text{Increment}) \\ \hline 1 \ 0000 \\ \hline \text{Carry} \end{array}$$

4) Decrement and borrow

$$\begin{array}{r} 0000 \\ - 1 \dots (\text{Decrement}) \\ \hline 1111 \\ \hline \text{Borrow} \end{array}$$

5) Exclusive OR

$$\begin{array}{r} 0 + 0 = 0 \\ 0 + 1 = 1 \\ 1 + 0 = 1 \\ 1 + 1 = 0 \end{array}$$

6. I/O Port

Port: Point of electrical access to a system or circuit

Port	DP	Bit [() = IC Terminal No.]			
		0	1	2	3
A ₀	0	REW switch (33)	PAUSE switch (34)		STOP switch (36) (I ₁ =0, I ₁ =1)
A ₁	0	REC switch	REV switch	FWD switch (35)	FF switch (I ₀ =1, I ₁ =0)
B	1	HEAD FWD (37)	REV erasure-proof switch (38)	FWD erasure-proof switch (39)	
C	2	MEMORY switch STOP (2)	MEMORY switch PLAY (3)	TIMER switch REC (4)	TIMER switch PLAY (5)
D	3	TAPE COUNTER switch (8)	MODE switch (9)	MODE switch (10)	SHUT OFF (11)
E	4	REV lamp (12)	FWD lamp (13)	FF lamp (14)	REW lamp (15)
F	5	REC MUTE (16)	PLAY MUTE (17)	PAUSE lamp (18)	REC lamp (19)
G	6		BRAKE SOLENOID (PM2) (23)	HEAD SOLENOID (PM1) (24)	REC bias (25)
H	7	KICK (26)	REEL MOTOR Speed Select (27)	REEL MOTOR ON/OFF (28)	CAPSTAN MOTOR ON/OFF (29)
I	8	A SELECT (30)	A SELECT (31)	REEL MOTOR FWD/REV (32)	X

Fig. 3

C-K96R

7. TERMINALS (Except I/O Port)

TERMINAL	TERMINAL No.	FUNCTION
CL1	(1)	CLOCK OSC OUTPUT
CL0	(2)	CLOCK OSC INPUT
INT	(6)	CAPSTAN MOTOR FG INPUT
RES	(7)	POWER ON/OFF INPUT
TEST	(20)	CONNECTED TO (21)

Fig. 4

8. RAM (Random Access Memory = Read out/Write in)



Address	0	1	2	3
¥ 0	REW switch	PAUSE switch		STOP switch
¥ 1	REC switch	REV switch	FWD switch	FF switch
¥ 2	HEAD FWD	REV erasure-proof switch	FWD erasure-proof switch	
¥ 3	MEMORY switch STOP	MEMORY switch PLAY	TIMER switch REC	TIMER switch PLAY
¥ 4	TAPE COUNTER switch	MODE switch 	MODE switch 	SHUT OFF
¥ 5	REV MODE	FWD MODE	FF MODE	REW MODE
¥ 6			PAUSE MODE	REC MODE
¥ 7	REC(ON/OFF)	TAPE COUNTER OFF→ON	TAPE COUNTER ON→OFF	
¥ 8	REC(ON/OFF)	6 COUNT		
¥ A	REPEAT	6 COUNT		
¥ B	FG COUNTER(High)			
¥ C	FG COUNTER(Low)			
¥ D	REC CHECK	FG COUNT and DATA INPUT		
¥ E	INPUT ON	INPUT CHECK		
¥ F	PAUSE CHECK			
¥ 10	DATA INPUT BUFFER (A0) · FG COUNT			
¥ 11	DATA INPUT BUFFER (A1) · FG COUNT			

Fig. 5

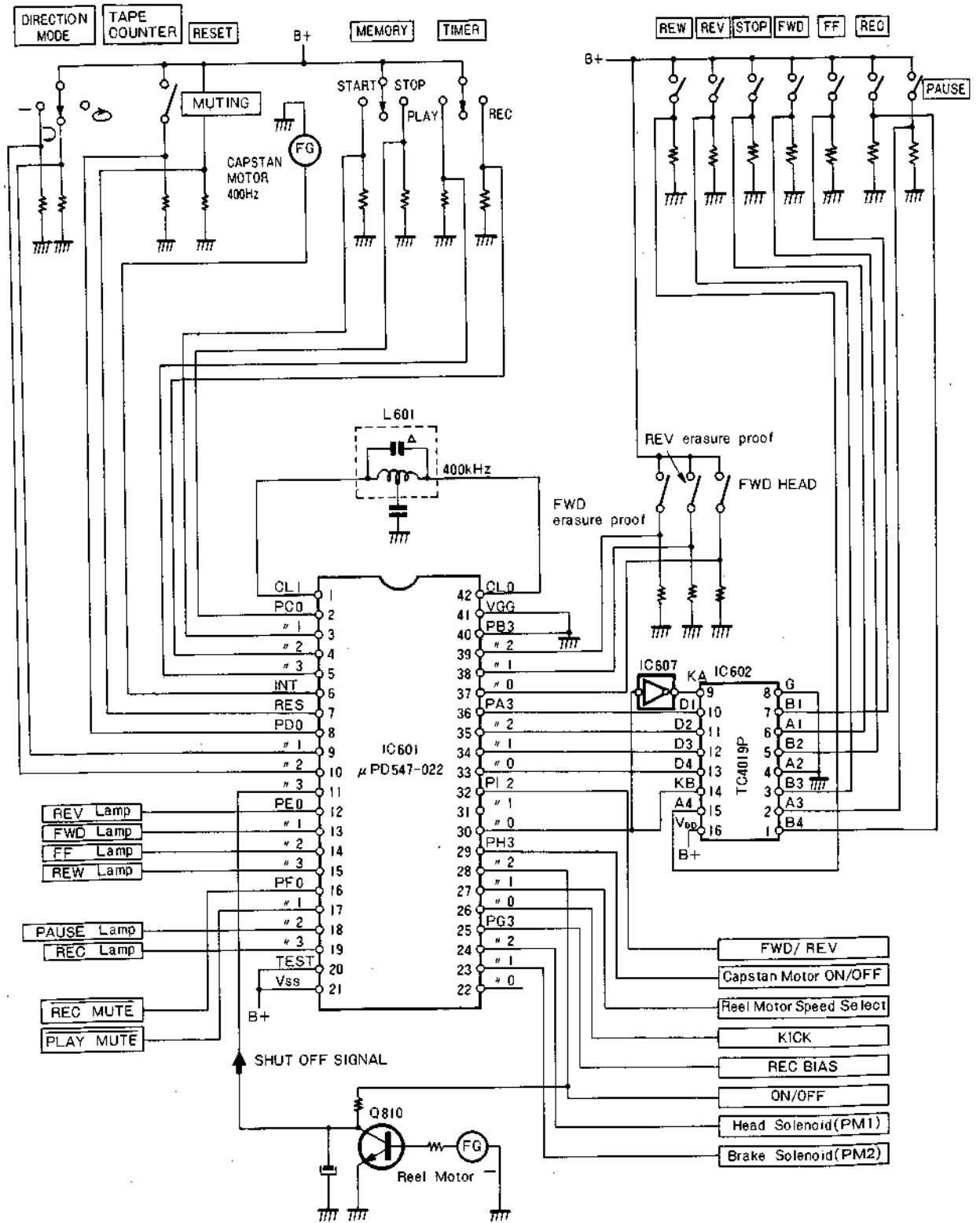

Fig. 6

C-K96R

9. IC INPUT/OUTPUT Timing Chart in Each Operation

1. Priority in Input Multiple Button Operations

STOP > REW > FF > FWD > REV
 STOP, REW, FF > REC, PAUSE

2. Input Inhibiting Condition

REC Inhibit in REW, FF, FWD, REV
 PAUSE Inhibit in REW, FF

3. Timing Chart in Each Operation

Note: When the KICK signal has been put out at the beginning of one operation (herein, operation A), even if another operation signal (herein, operation signal B) is given it (the operation signal B) will be stored within and the operation B will be carried out after the KICK output is reset.

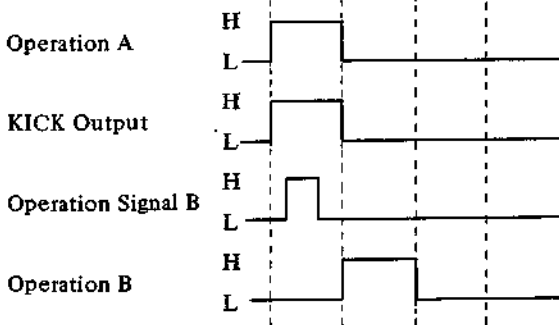
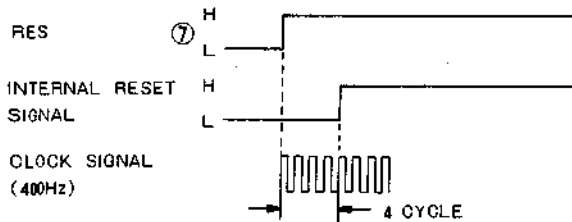

Fig. 7

The numerals in the timing chart of each part are the number of inputs of INT (FG input of the capstan motor is 400 Hz).

The encircled numbers are terminal numbers in the IC.

1) When POWER switch is turned on



After 4 cycle of clock signal, all of output terminals are reset.

Fig. 8

2) When STOP button is depressed.

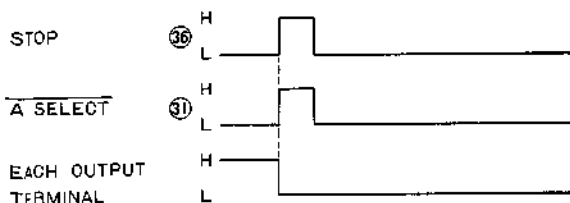

Fig. 9

3) When REW button is depressed.

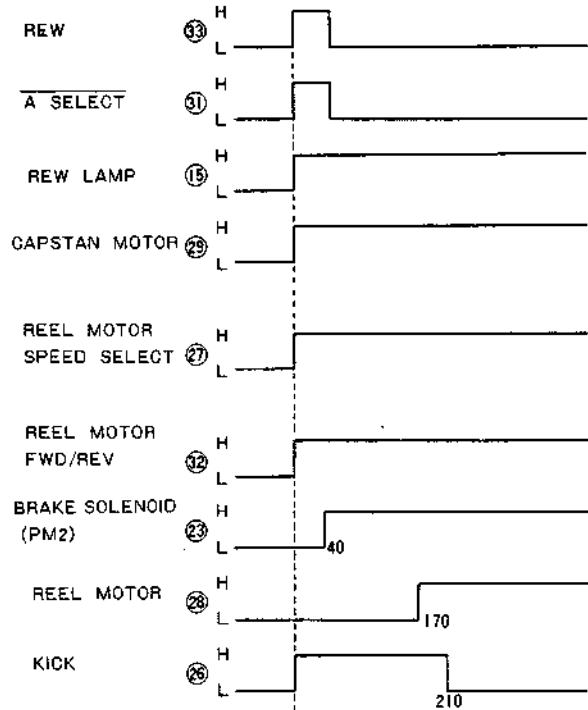

Fig. 10

4) When FF button is depressed.

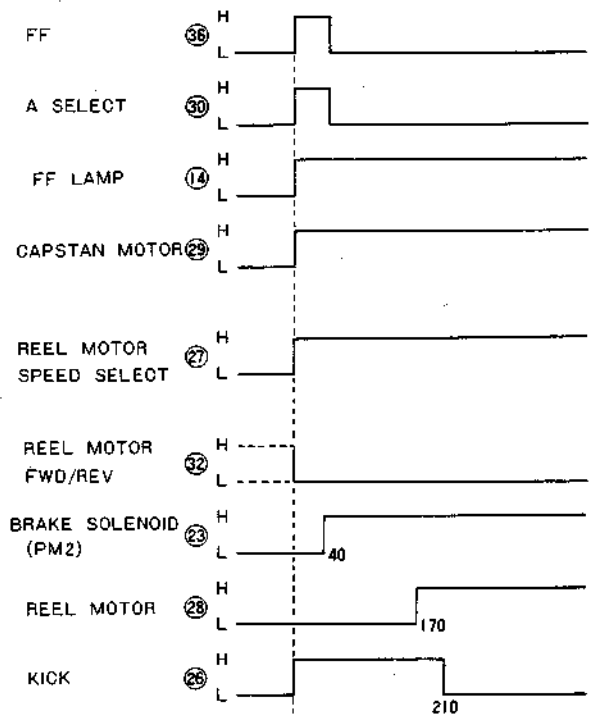

Fig. 11

5) When FWD button is depressed.

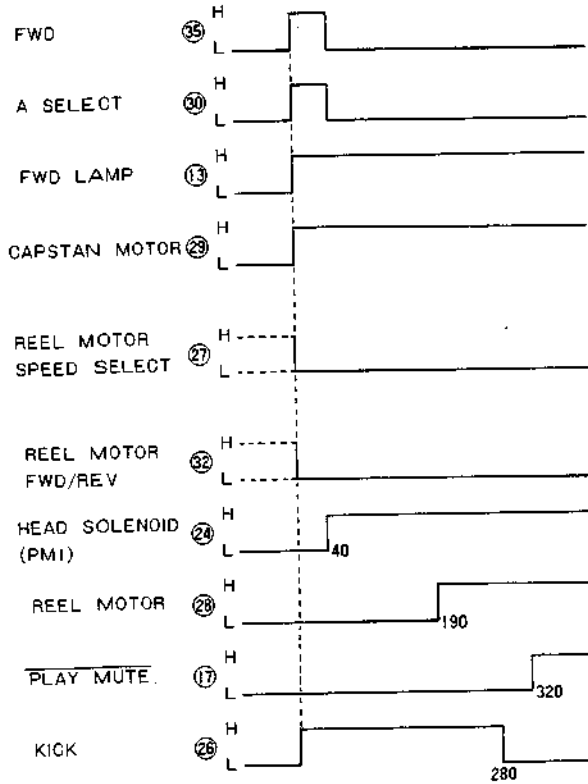

Fig. 12

6) When REV button is depressed.

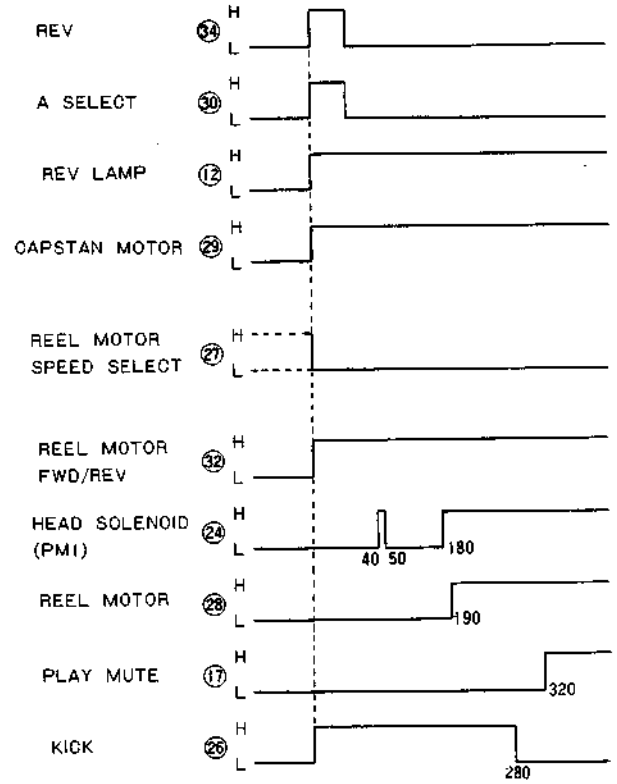
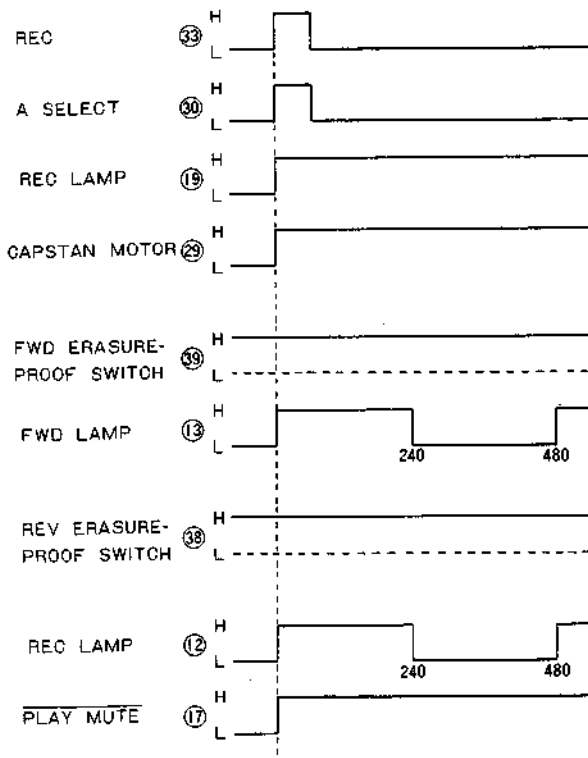
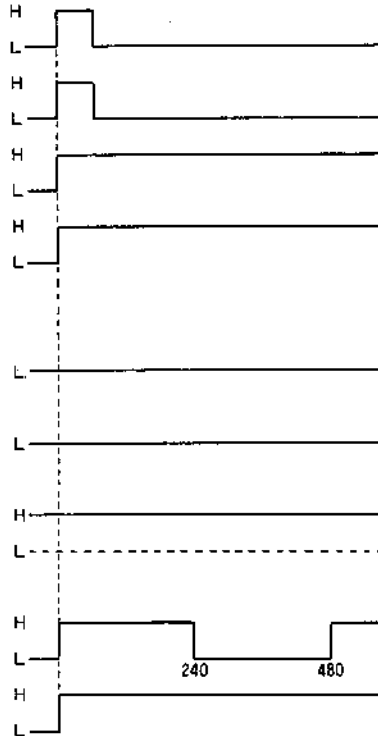

Fig. 13

7) When REC button is depressed.



FWD accidental erasure-proof claw is cut off.



FWD · REV accidental erasure-proof claw is cut off.

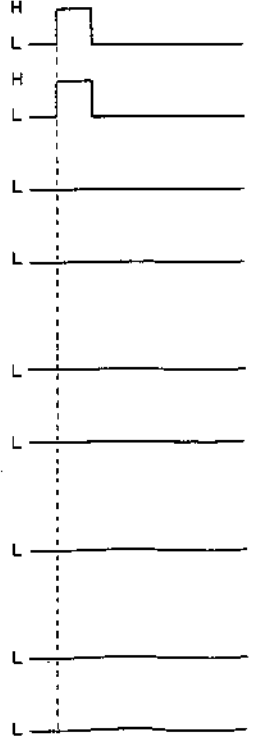

Fig. 14

8) When REC·FWD button is depressed.

When REC·REV button is depressed in PAUSE mode.

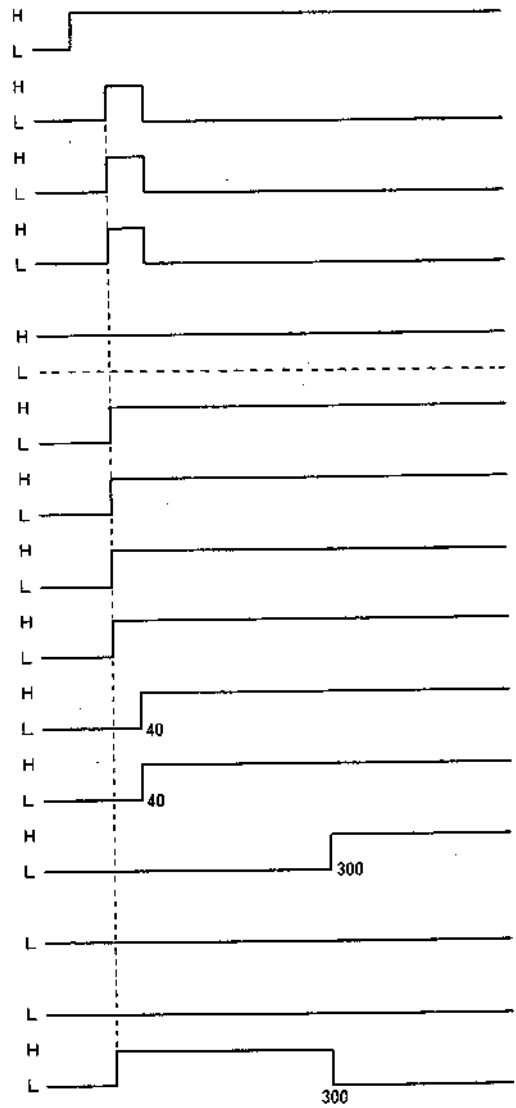
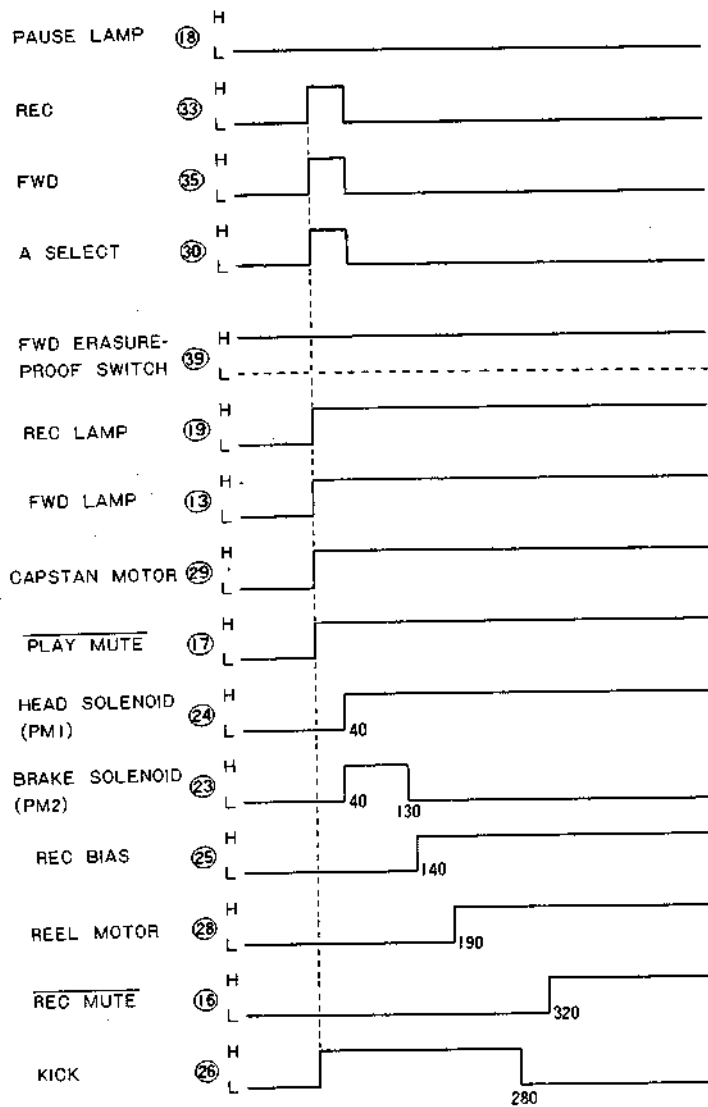

Fig. 15

9) When REC·REV button is depressed.

When REC·FWD button is depressed in PAUSE mode.

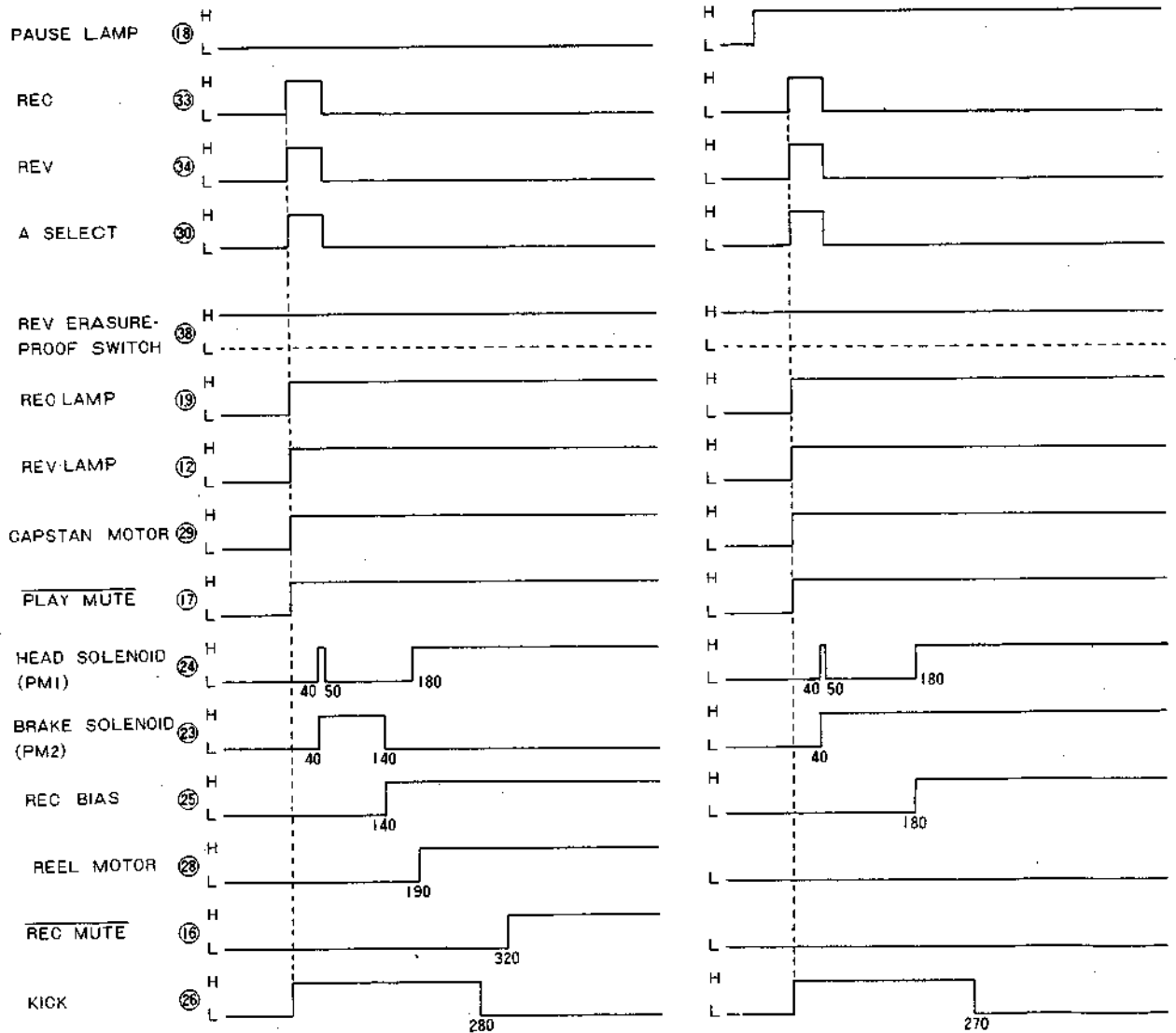

Fig. 16

10) When PAUSE button is depressed.

(a) Depress PAUSE button in STOP mode.

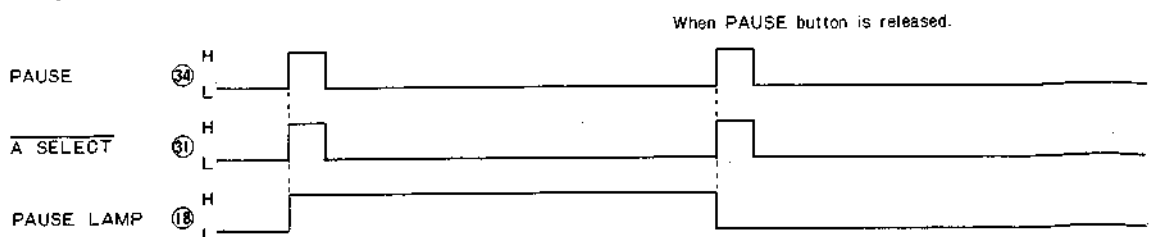

Fig. 17

C-K96R

(b) Depress PAUSE button in FWD, REW, REW · FWD or REC · REV mode.

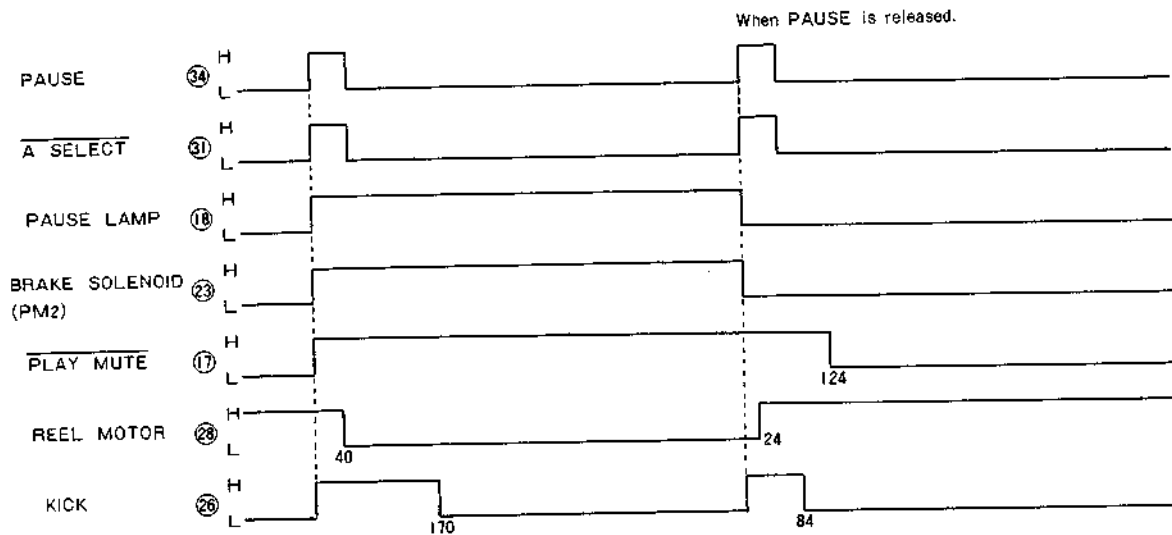

Fig. 18

11) When FWD or REV button is depressed in PAUSE mode.

(a) When FWD button is depressed.

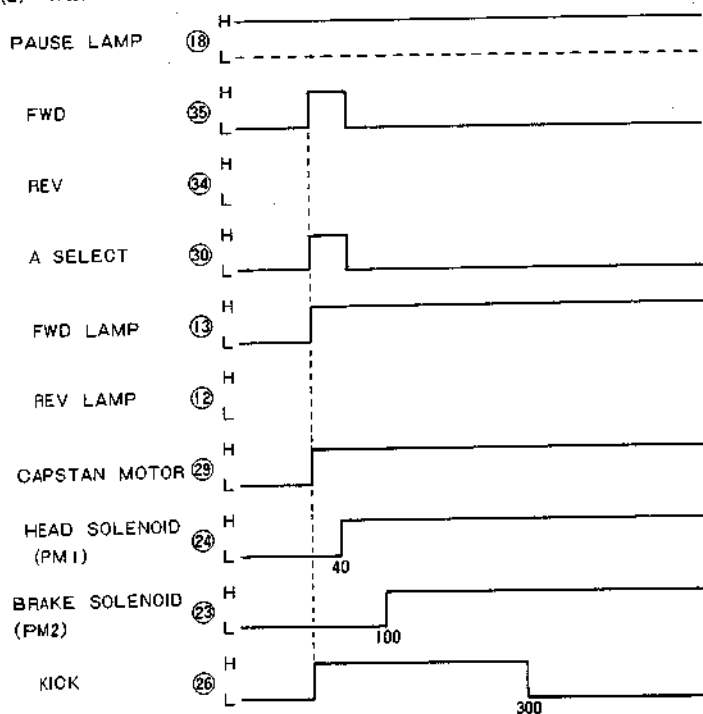

Fig. 19

(b) When REV button is depressed.

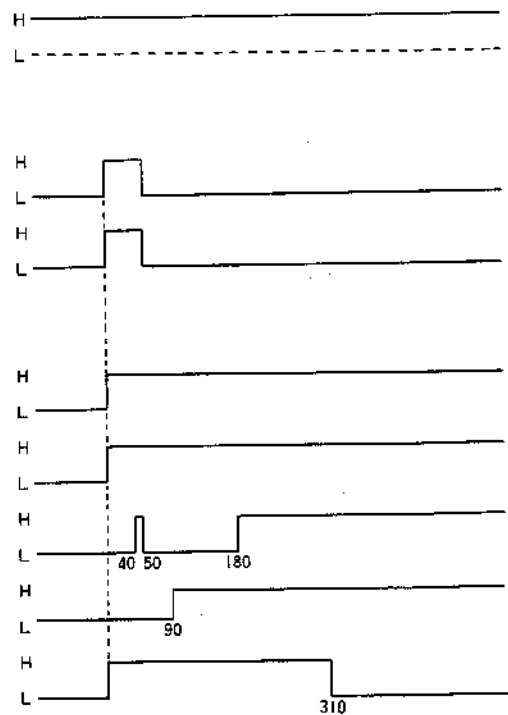

Fig. 20

12) MEMORY switch

When the tape counter indicates "999" from "000" or "000" from "999" during FF or REW mode, the set stops or starts to play.

(a) Depress REW button in FWD mode.

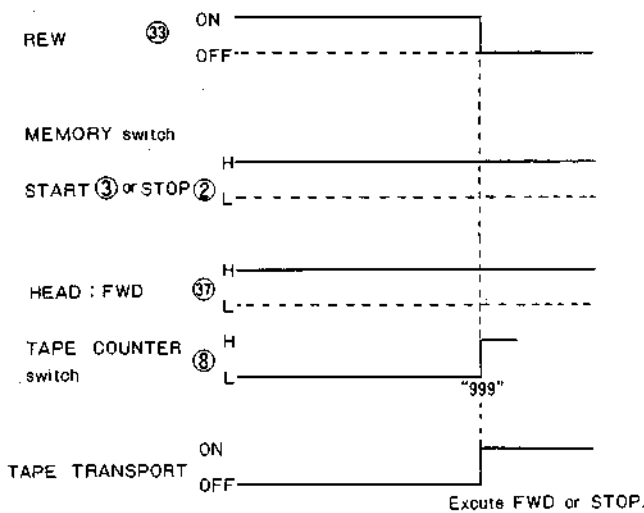

Fig. 21

(b) Depress FF button in REV mode.

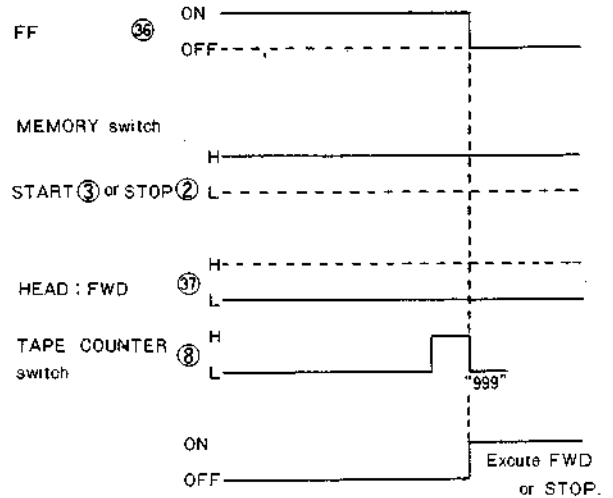

Fig. 22

13) SHUT OFF

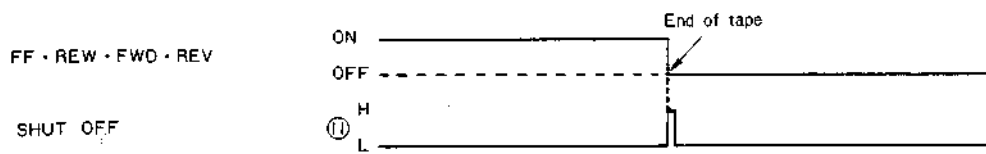

Fig. 23

14) MODE switch select.

(a) MODE switch: — position

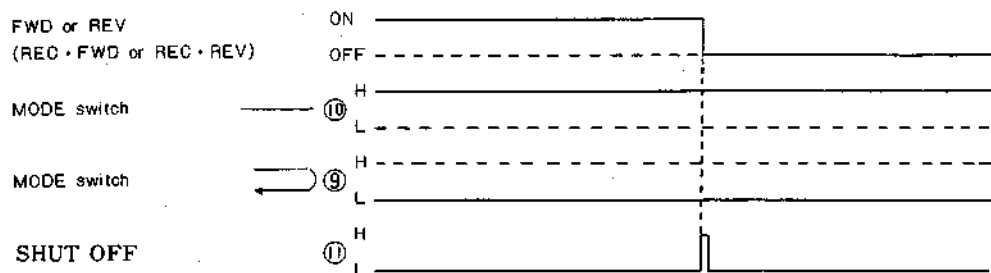



Fig. 24

(b) MODE switch :  position

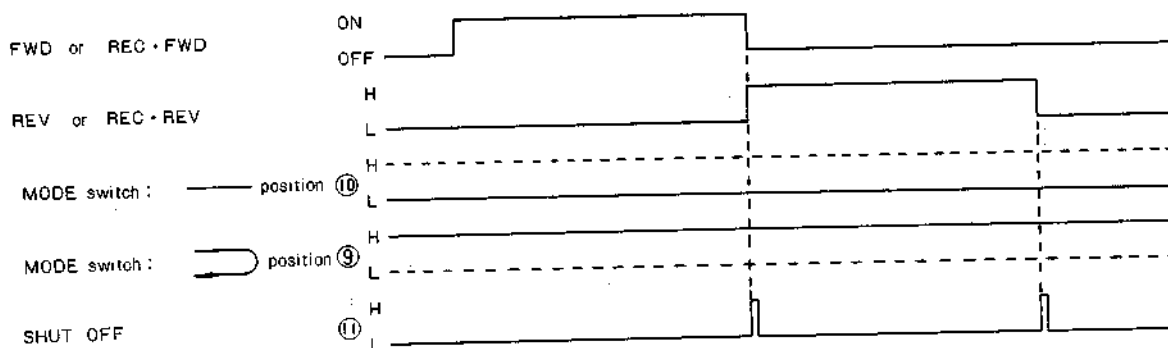



Fig. 25

(c) MODE switch :  position

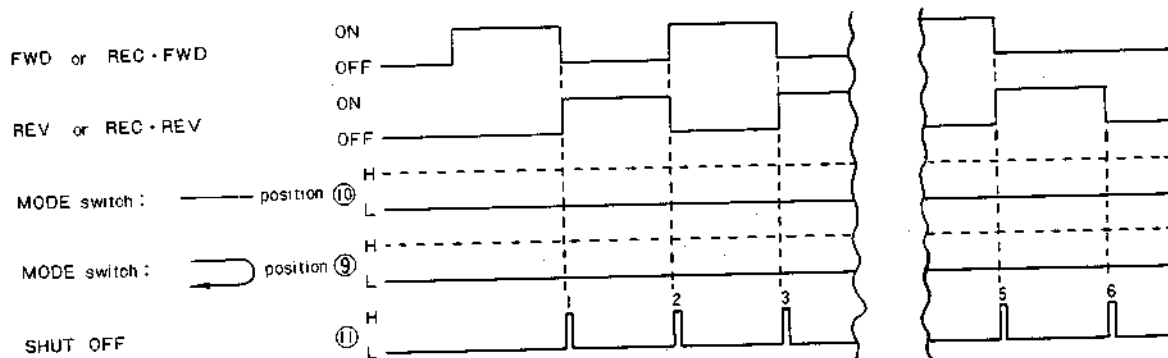

Fig. 26

15) TIMER · REC or TIMER · PLAY

(a) TIMER · REC

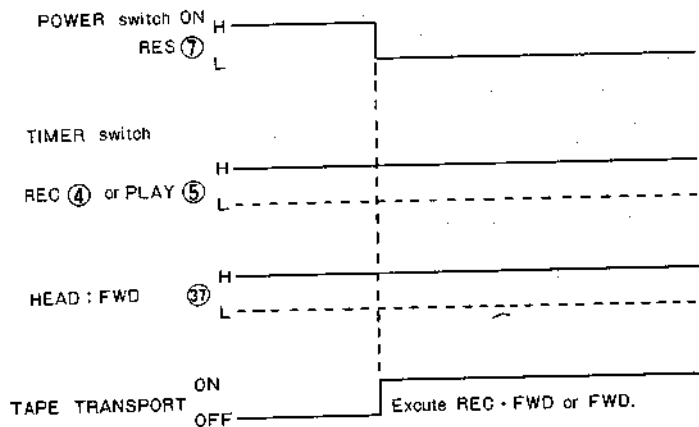

Fig. 27

(b) TIMER · PLAY

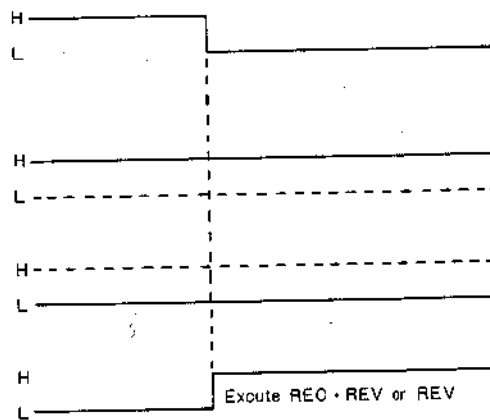
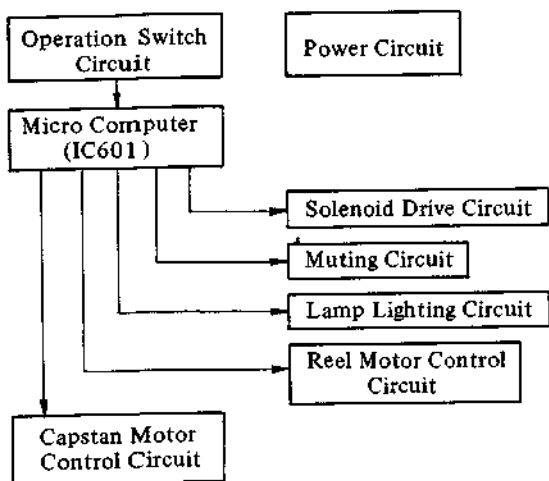

Fig. 28

10. SYSTEM CONTROL CIRCUIT

An outline of the micro computer was given in Chapter 1 ~ 3. An explanation of the system control circuit of this device will now be given.

The system control circuit in this device is composed of the following blocks built around the micro-computer (IC601).



The IC601 sends out the output signals of ON (HIGH)/OFF (LOW) to each block corresponding to the input signals from the operation switches or from the reel or capstan motor control circuits.

An explanations of each of the blocks follows:

1) FUNCTION Switch Circuit

(a) The signals for the five operations of REW, REV, STOP, FWD, FF are sent out on two lines from the FUNCTION switches. The priority level is determined by the switch arrangement and the resistor values.

The OP amplifier in Fig. 29 is employed as a comparator circuit. When the switch is off, because the potential of the (-) terminal is higher than that of the (+) terminal in the OP amplifier input, the output of the OP amplifier goes to the low potential level.

Next, when the switch is on, because the potential of the (+) terminal is higher than that of (-) terminal, the output of the OP amp goes to HIGH.

Here five OP amplifiers are combined and the voltages of the (-) terminals of the OP amplifiers are compared when the switches are pressed and then the mode of operation is decided.

(Example) When STOP switch (S12) is pressed: When S12 is pressed, the outputs of IC1~5 go HIGH. However, since Q624~627 are turned on, the outputs of IC1~4 will be muted, and only the output of IC5 (STOP signal) will be effective output.

(1) Drive Table for IC1~5, Q624~627

(2) (When IC output is high-potential => 0) When it is low-potential -> X

Switch	IC1	IC2	IC3	IC4	IC5	Q624	Q625	Q626	Q627
STOP	0	0	0	0	0	ON	ON	ON	ON
REW	0	0	0	0	X	OFF	ON	ON	ON
FF	0	0	0	X	X	OFF	OFF	ON	ON
FWD	0	0	X	X	X	OFF	OFF	OFF	ON
REV	0	X	X	X	X	OFF	OFF	OFF	OFF

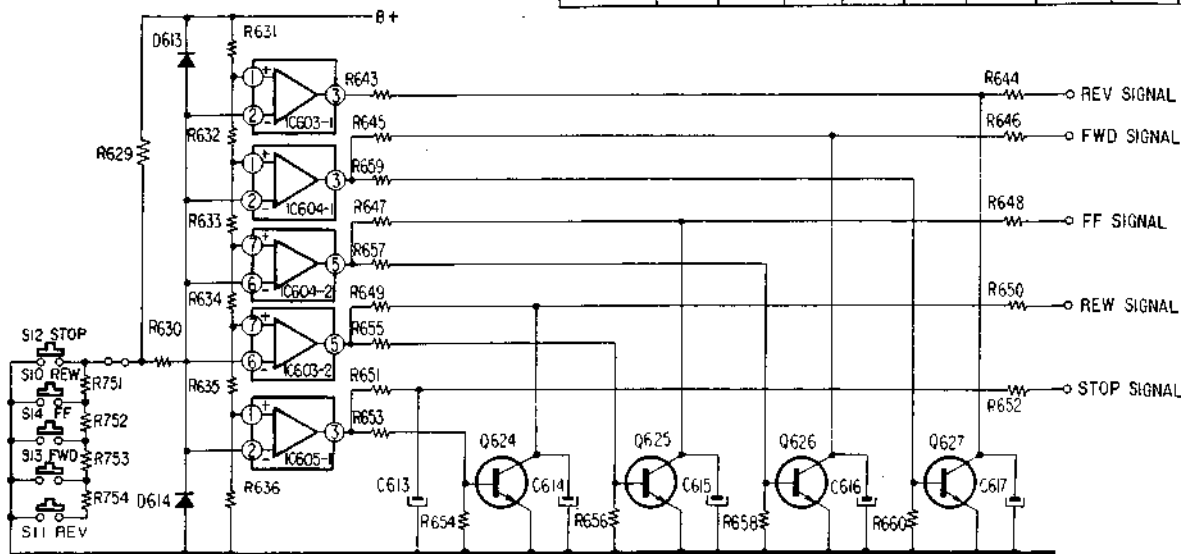

Fig. 29

C-K96R

- (b) The modes of REC and REC MUTE in recording are determined by the OP amplifiers as in (a). (Fig. 30)
- When the REC MUTE switch (S17) is pushed, the output of IC6 goes HIGH generating the REC MUTE signal.
 - When the REC switch (S15) is pushed, the outputs of IC6.7 go HIGH. However, since Q611 is turned on, the output of IC6 is muted, and only the REC signal is output.
 - When the REC switch (S15) and REC MUTE switch (S17) are simultaneously pushed, outputs of IC6.7 go HIGH, and the output of IC8 goes LOW. Therefore, the REC MUTE signal, which has been muted by Q611 during recording will have its muting condition released because Q611 is turned off by D617 IC8.
- (c) The PAUSE circuit operates independently by switching Q631 in order to prevent chattering.

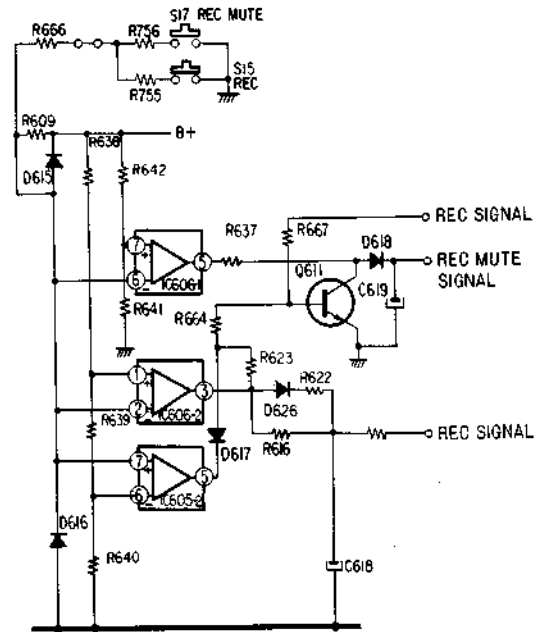

Fig. 30

2) Muting Circuit

- (a) In the STOP, FF and REW modes, since PLAY MUTE of IC601 goes LOW. Q609 will be turned off, the muting signal will be applied to Q110.111 (210, 211), and LINE OUT will be muted.
- (b) In FWD.REV, since PLAY MUTE of IC601 goes HIGH, Q609 is turned off, and the muting will be cancelled.
- (c) Q610 is the muting circuit for delayed recording.

- (d) Q618 is turned on by the REC MUTE signal from the operation switch circuit, and PL10 lights up. Further, since Q618 goes on, and the REC MUTE signal from IC601 goes grounded via D623, Q603 will be turned off, and because the REC MUTE signal gets applied to Q114(214), consequently the recording signal will be muted.

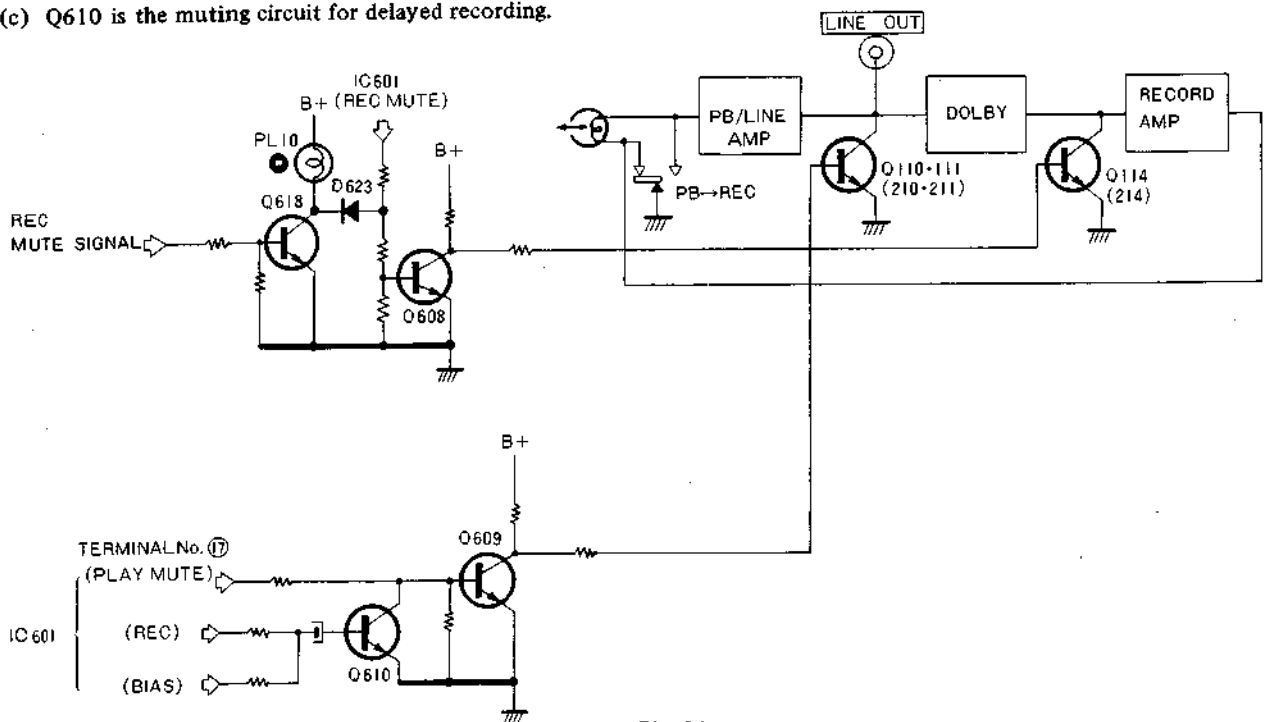

Fig. 31

3) Power Circuit, Solenoid drive

- (a) Reset when the power switch is turned on or off
- When the power switch is turned on: for three seconds when the supply voltage charges C624 through R703, the Schmitt circuit formed by the inverters (IC602) operates and sends the reset signal to IC601.
 - When the power switch is turned off: because C624 discharges due to the fall in the primary voltage, the Schmitt circuit operates and sends the reset signal to IC601.
- (b) The solenoids (PM1,2) are driven by the signals PM1, PM2 from IC601, via the Darlington amplification circuits of Q619, 620, Q621, 622. The solenoids are driven by HIGH voltage level only while retracting because Q607, 606 are turned on by the KICK signal sent simultaneously with the signals PM1, PM2. This is to prevent excessive heat generation.

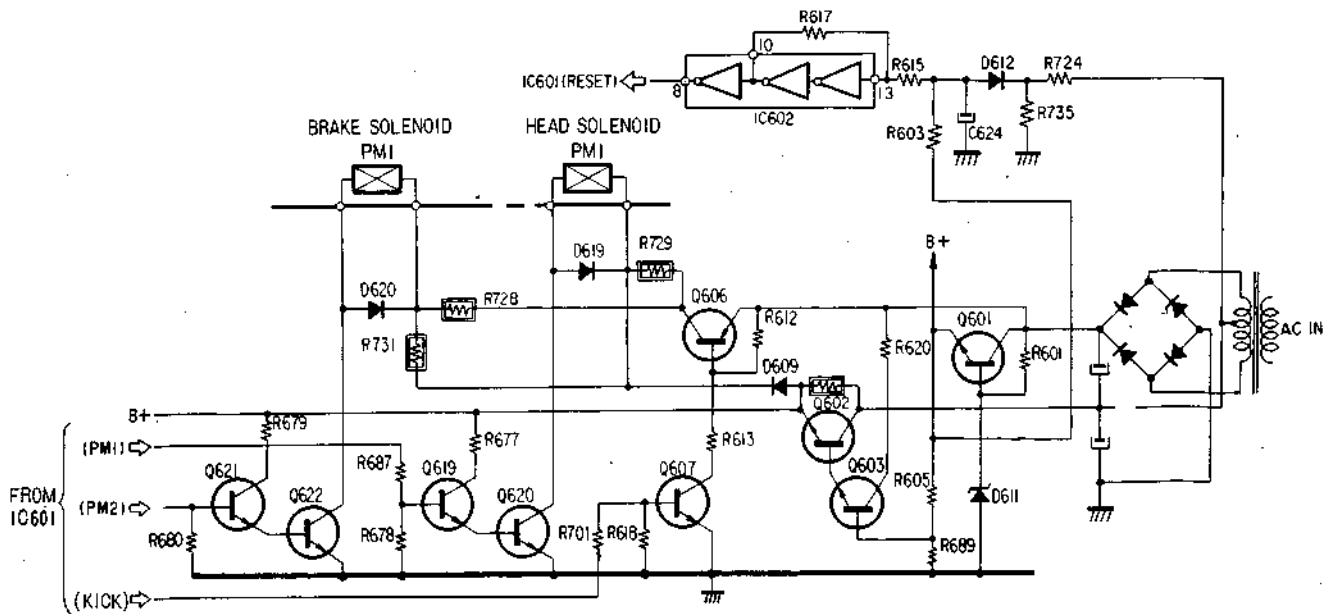

Fig. 32

4) Capstan Motor FG Signal Circuit

The FG frequency of the capstan motor is 133 Hz. For this purpose, pulses are generated by Q806, 807 at the rise and fall of the output waveform at terminal No.2 of IC801. Further, the motor output signal $\phi 1$ is wave-shaped in the comparison circuit of the operational amplifier (IC804), and pulses are generated at its rising edge. These pulses are added producing pulses with three times the frequency (about 400 Hz) from the fundamental FG frequency (133 Hz).

The FG pulses of 400 Hz generated in the servo circuit are used as the fundamental frequency for IC601 (micro-computer) after being shaped and adjusted in time phase by a Schmitt circuit mode up of inverters.

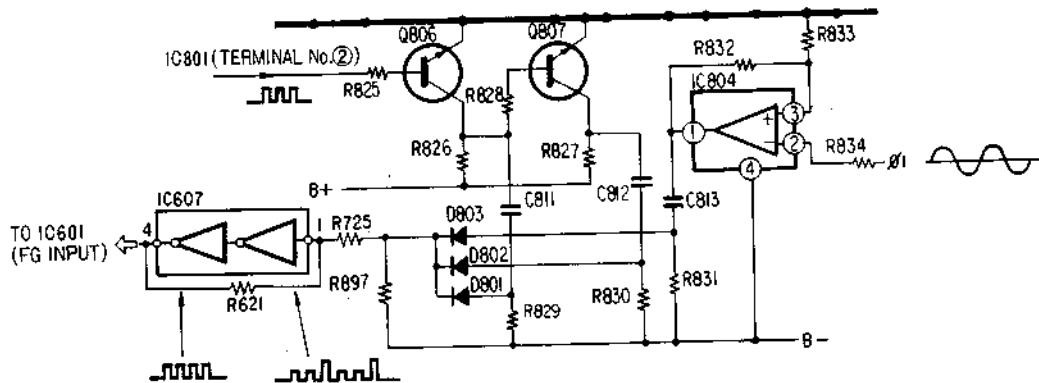

Fig. 33

5) Reel Motor Control Circuit

The OP amplifier (IC804) generates output voltages of positive, 0, negative with respect to the virtual ground this is not chassis ground, but has a potential of +10V). As a result, the reel motor (BSL) rotates in the forward or reverse directions in accordance with the output potential of the OP amplifier.

(a) FWD/REV Switching of the Reel Motor

Due to the reel motor signal FWD/REV from IC601, Q809 will be turned off in FWD and FF modes, B + is applied to the (+) terminal of IC804, and the output of the OP amplifier becomes positive.

Next, in the REV and REW modes, because Q809 is turned on, the potential of the (+) terminal of IC804 becomes lower than that of (-) terminal, and the output of the OP amplifier goes negative. As a result, by turning on or off Q809, the rotating direction of the reel motor will be reversed.

(b) ON/OFF Switching for Reel Motor

When the reel motor is off, Q811 is turned on due to the signal ON/OFF of the reel motor, so that the output of the OP amplifier becomes 0 volts, and the reel motor does not rotate.

(c) Magnetic Brake in FF/REW of Reel Motor

When the reel motor is rotating, C814 is charged to B+ or B-. Because this capacitor discharges to imaginary ground when the reel motor stops (Q811 = ON), a voltage opposite in polarity to that during rotation will be applied to the (+) terminal of the OP amplifier.

Consequently, the reel motor tries to rotate in the opposite direction, and hence this operates as a brake which stops quickly the rotation in the FF, REW modes.

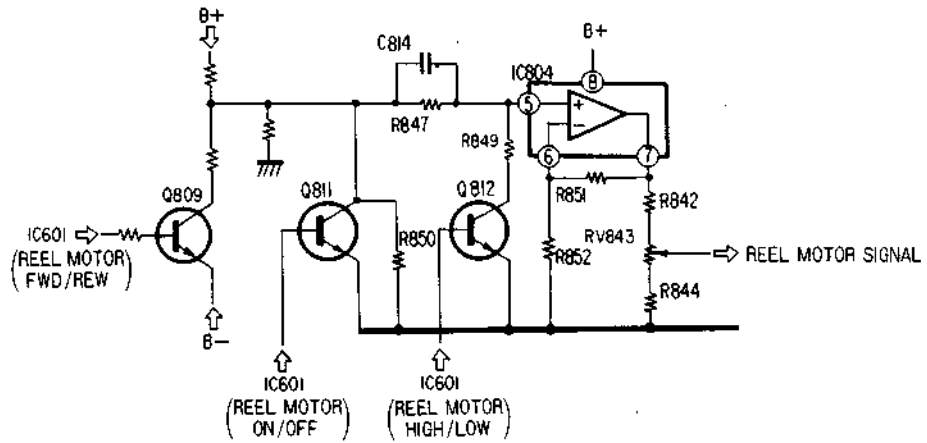

Fig. 34

6) BSL (brush and slotless) motor

(a) The BSL motor, which employs the hall element as an electronic switcher, has the low noise and the stable performance.

Hall Element:

The magnetic field strength is converted into electrical signals by employing the Hall Effect.

Hall Effect:

When a metal strip is placed with its plane perpendicular to a magnetic field and an electric current flows longitudinally through the strip, a potential difference is developed across the strip at right angles to the current flow and to the magnetic field.

The potential is proportional to amounts of the current and a strength of the magnetic field.

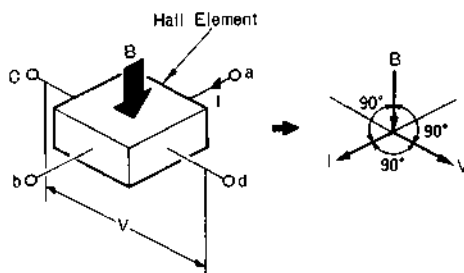

When the current I flows through the hall element (a-b), the potential V is developed across c-d.

Fig. 35

(b) BSL motor and its drive circuit.

The motor magnet is magnetized in 8 poles (sinusoidal patterns).

The constant current I is supplied to the hall element H1.

When the H1 comes to the N pole of the magnet, the voltage is generated in the H1.

This voltage is fed to IC803-1 and Q815 turns on. Therefore, the current $\phi 1$ is supplied to the motor coils through Q815.

At this moment, by the Fleming's left-hand rule, the magnetic force (F) is produced in the motor coils.

And the magnet rotates in the opposite direction of the magnetic force, since the motor coils are fixed.

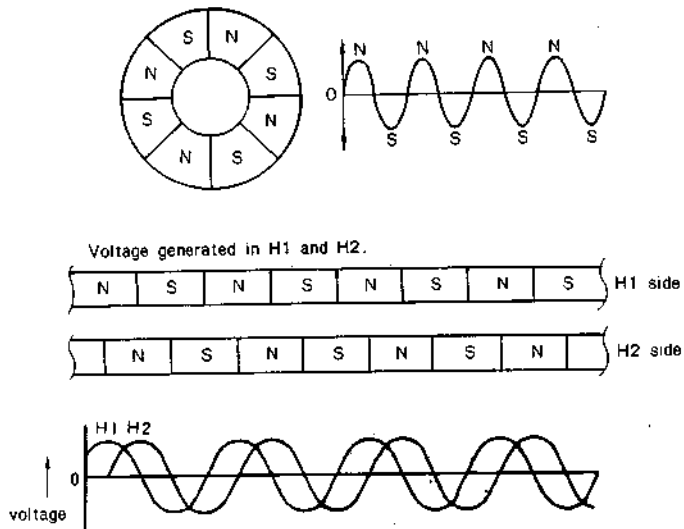

Fig. 36

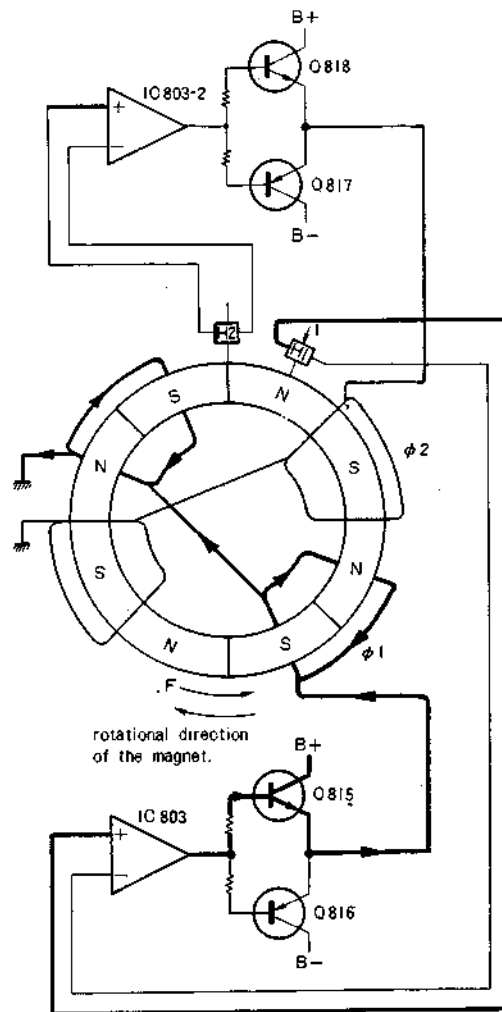

Fig. 37

US Model
 Canadian Model
 AEP Model
 UK Model
 E Model

SUPPLEMENT

File this supplement with the service manual.

No. 2
 November, 1979

- ① The photo-coupler circuit has been added to improve the auto shut-off mechanism.

ADDED PARTS

Ref. No.	Part No.	Description
	▲ 1-602-215-00	Printed Circuit Board, photo-interrupter
D1001	8-719-101-11	SR110
D1002	8-719-815-55	1S1555
Q1001	8-729-101-13	PH103
Q1002	8-729-663-47	2SC1364

CHANGED PARTS

Ref. No.	Description	Part No.	
		Former Part	New Part
S24	Bracket, tape counter Tape Counter, w/switch	▲ 3-558-330-00	▲ 3-558-486-00
		1-548-526-00	1-548-526-21

- Items marked "▲" are not stocked since they are seldom required for routine service. Some delay should be anticipated when ordering these items.

- ② The auto shut-off mechanism is supplied as the kit specified below.

Description	Part No.
photo-coupler kit	X-3558-342-1

SONY
 SERVICE MANUAL

• Replacement Semiconductors

For replacement, use semiconductors except in ().

Q601 : 2SC1173

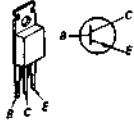

Q811, 812 : 2SC1364 (2SC834A)

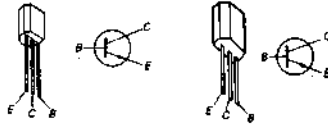

D601 ~ 604, 607 } 10E2
 D609, 619, 620 }
 D801 ~ 809 } 1S1555
 D612 ~ 618 }
 D622, 623, 626 }
 D627 : 1S1555 (1T40)

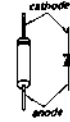

Q602 : 2SC1061 (2SC1419)

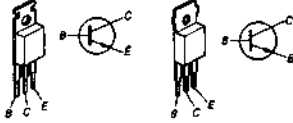

Q814, 819 : 2SA678 (2SA677)

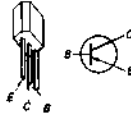

D608 : EQB01-15 (EQA01-15R)
 D611 : EQB01-11Z (EQA01-11R)



Q603, 607 ~ 619 }
 Q621, 624 ~ 627 } 2SC1364 (2SC1634)
 Q629, 631 }
 Q801, 808, 810 }
 Q820, 821 }

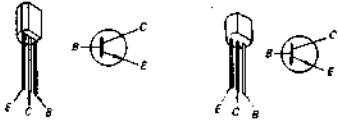

Q1001 : PH103

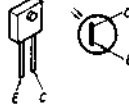

D605, 606 : S1VB10

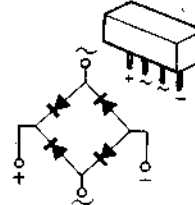

Q604 : 2SA678

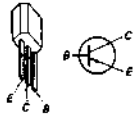

Q1002 : 2SC1364

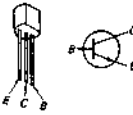

IC601 : μ PD547-022

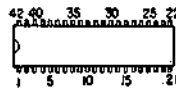

(Top view)

D1001 : SR110

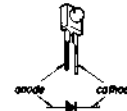

Q605, 606 : 2SB605

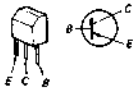

Q620, 622 } 2SD571
 Q628 }

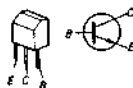

IC602 : TC4019P

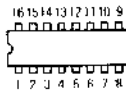

(Top view)

D1002 : 1S1555



Q803, 804 } 2SB548
 Q816, 817 }

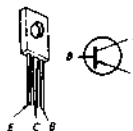

IC607 : TC4069P

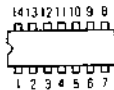

(Top view)

Q802, 805 } 2SD414
 Q815, 818 }

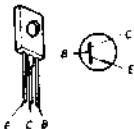

IC801 : CX065A



IC603 ~ 606 : μ PC4557C (μ PC4557)
 IC802 ~ 804 : μ PC4558C (μ PC4558)

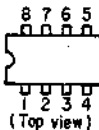





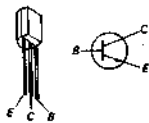







(Top view)

Q806, 807 } 2SC1364 (2SC945)
 Q809, 813 }



SCHEMATIC DIAGRAM —System Control Section—
(pages 24-26 of the service manual)

-  : added portion
- All capacitors are in μF unless otherwise noted. pF = $\mu\mu\text{F}$
50 WV or less are not indicated except for electrolytics.
- All resistors are in ohms, $\frac{1}{2}\text{W}$ unless otherwise noted.
 $\text{k}\Omega = 1000\Omega$, $\text{M}\Omega = 1000 \text{k}\Omega$
-  : panel designation
-  : nonflammable resistor.
- (N) : low-noise resistor.
-  : B + bus.
- Readings are taken under no signal conditions with a VOM (20 $\text{k}\Omega/\text{V}$).
 -  : Rewind
 -  : Reverse
 -  : Forward
 -  : Fast Forward
 -  : record
 -  : pause
 -  : rec mute
 -  : stop
- Voltage variations may be noted due to normal production tolerances.
- Switch

Ref. No.	Switch	Position
S10-15	FUNCTION	FORWARD
S16	PAUSE	OFF
S17	REC MUTE	OFF
S18	TIMER	OFF
S19	MEMORY	OFF
S20	DIRECTION MODE	
S21	REVERSE	OFF
S22	ERASURE PROOF	OFF
	FORWARD	OFF
S23	ERASURE PROOF	OFF
	CASSETTE LID	OFF
S24	TAPE COUNTER	OFF
S25	DIRECTION	FORWARD
S26	POWER	OFF

Note: The components identified by shading and mark  are critical for safety. Replace only with part number specified.

Note: Les composants identifiés par un trame et une marque  sont critiques pour la sécurité. Ne les remplacer que par une pièce portant le numéro spécifié.

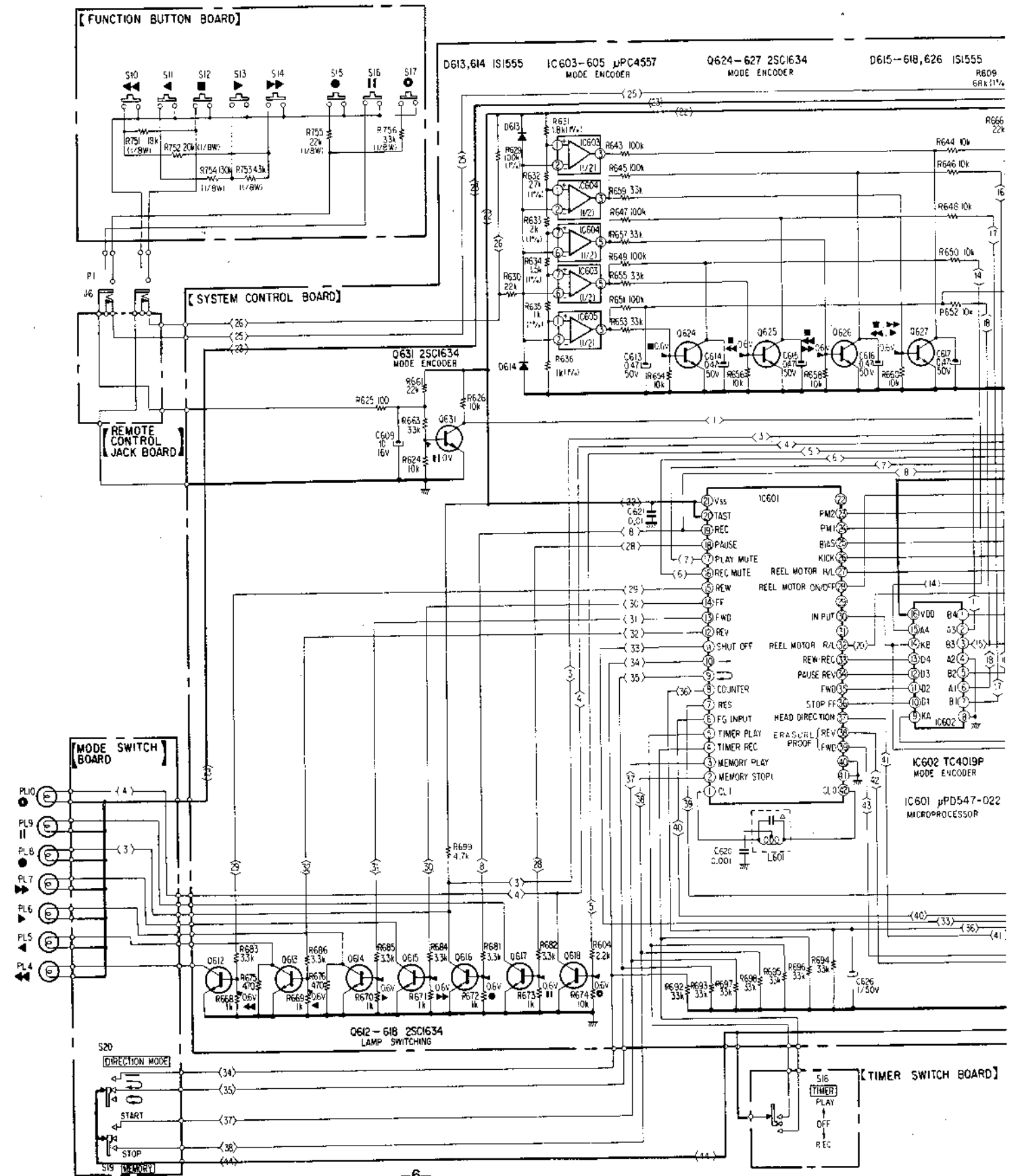

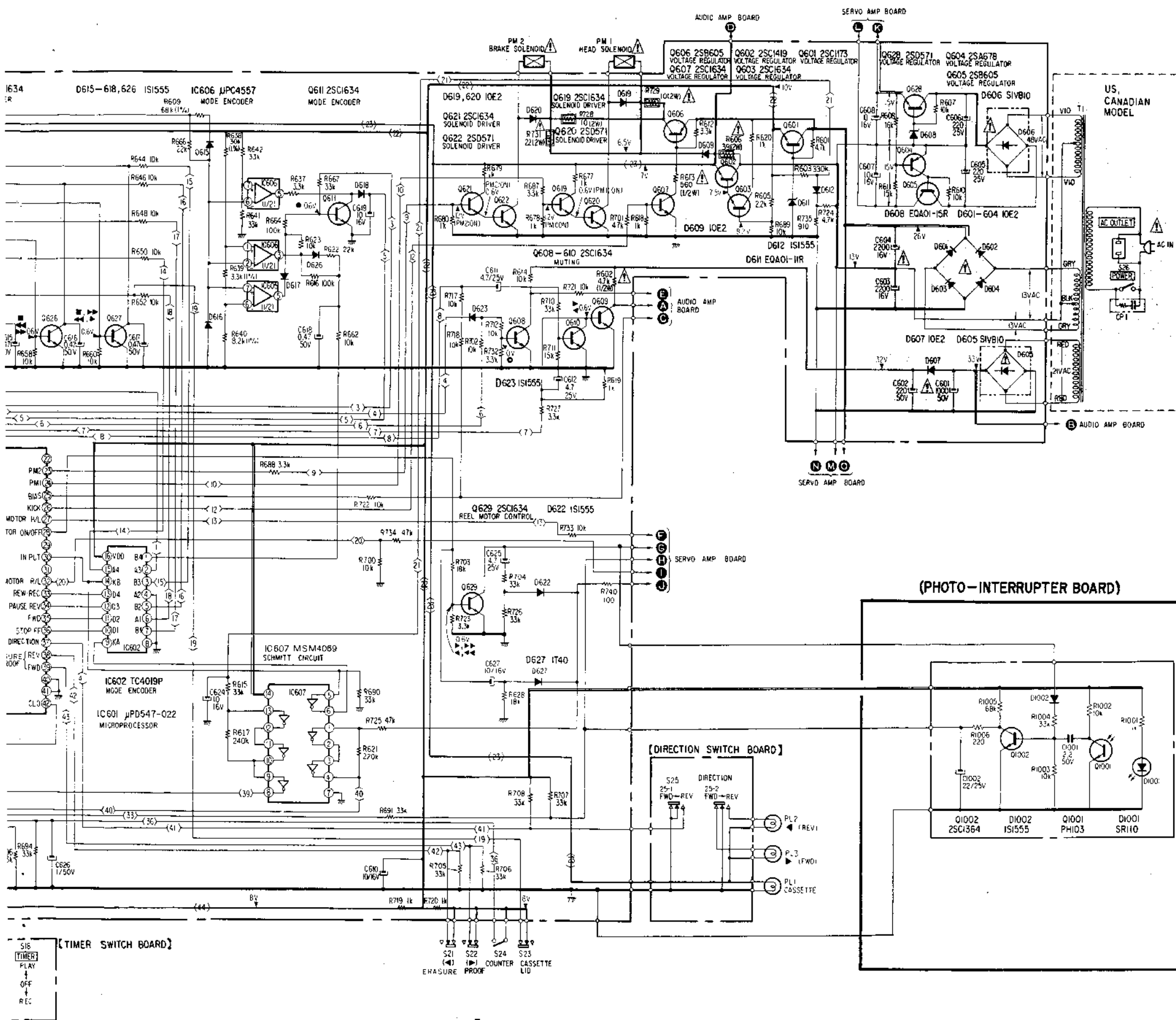

US, CANADIAN MODEL

(PHOTO-INTERRUPTER BOARD)

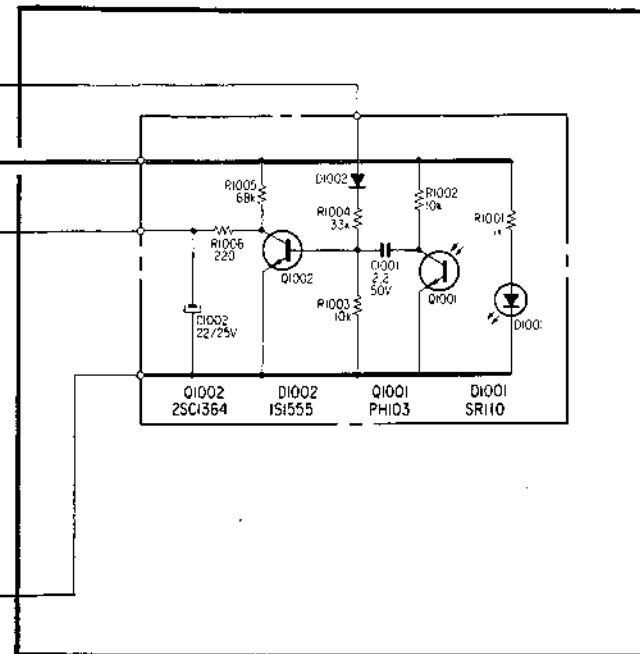

(DIRECTION SWITCH BOARD)

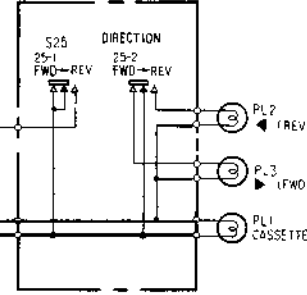

(TIMER SWITCH BOARD)

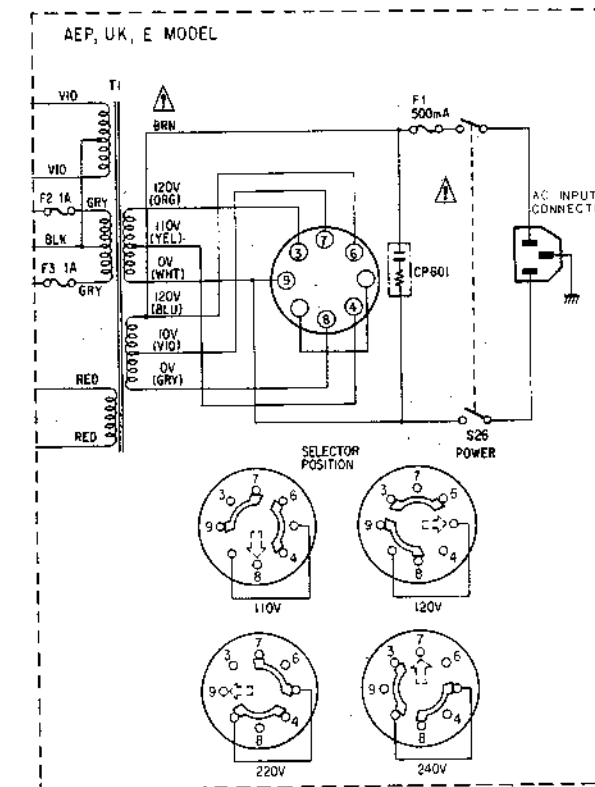
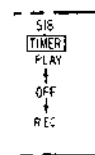

MOUNTING DIAGRAM - System Control Section -
 - Conductor Side - (pages 27-29 of the service manual)

Q, IC	D
603	51
602	
60	
605	80
607	80
606	802
504	603
606	804
609	
610	612
628	605
607	
IC607	
620,63	609
608	
606	
621	5 6
622,67	
629	
61	620,51E
621	
621	526
626	
IC 606	627,622
IC 607,605	
62	617
63	
IC60	
IC 603,604	
613	
611	615,616
614	63 4
6	614

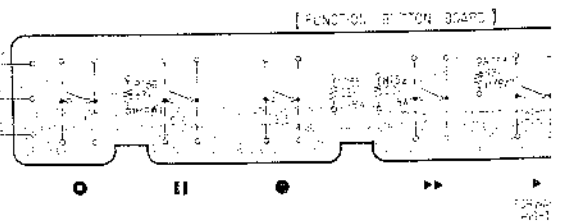
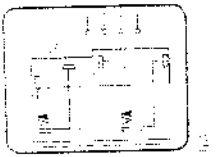
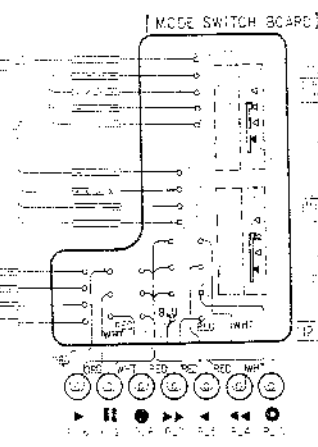
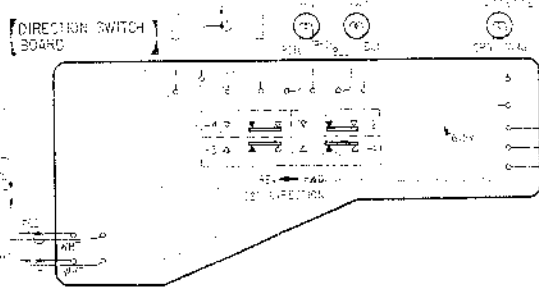
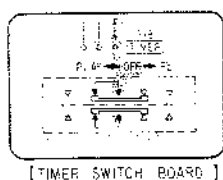
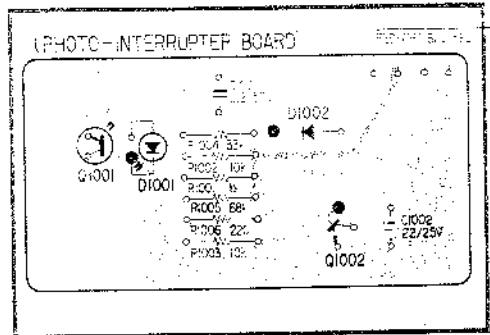
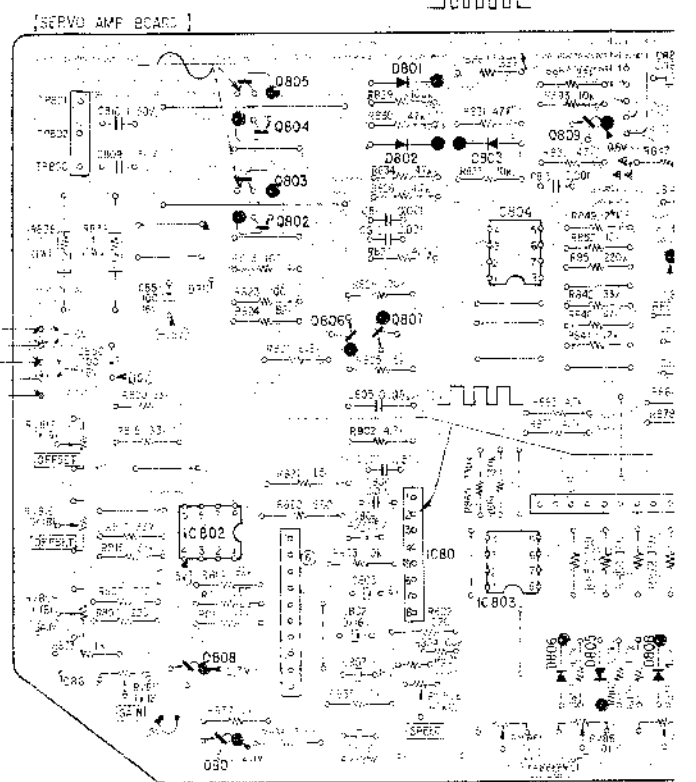
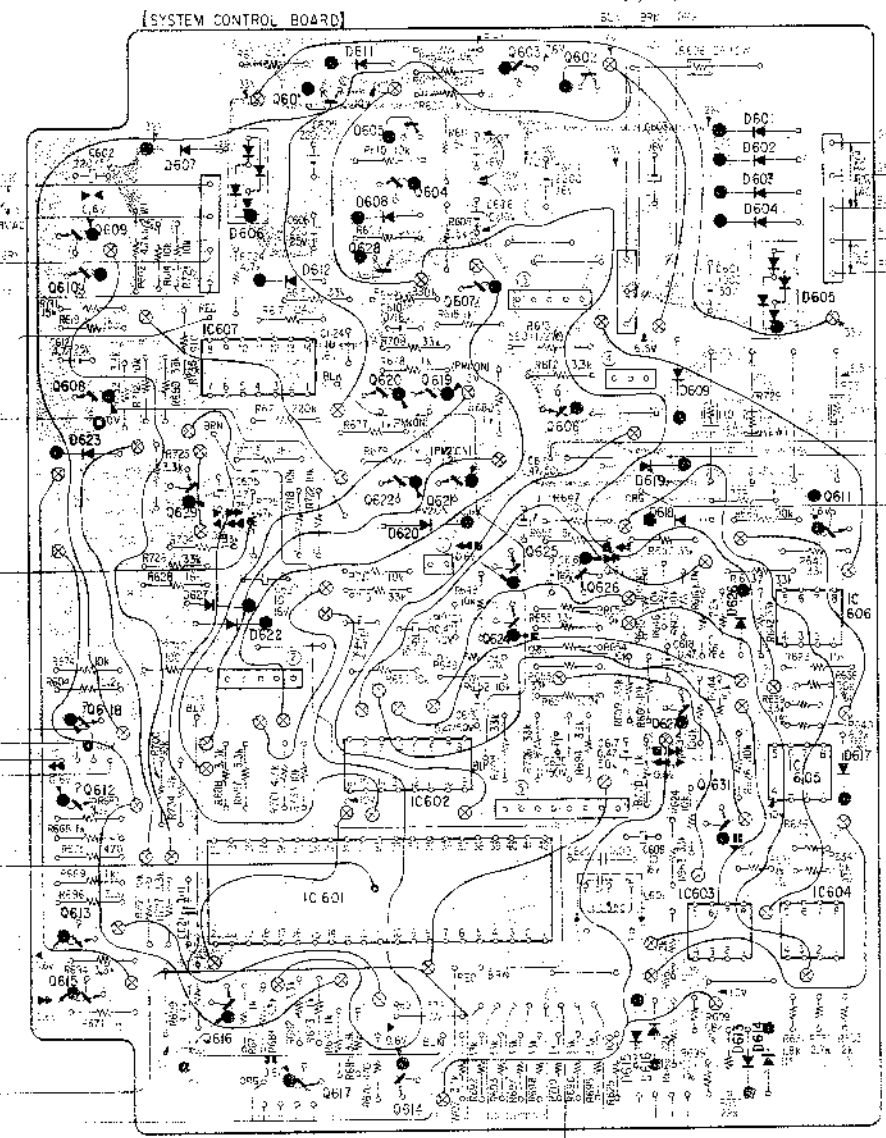
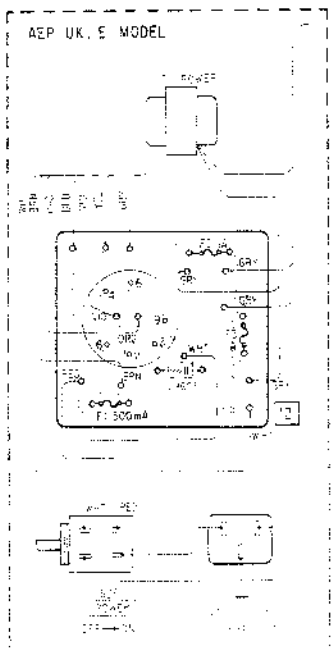
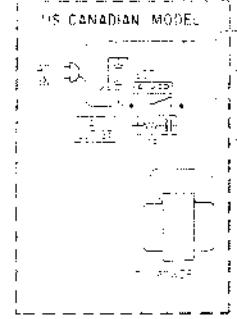

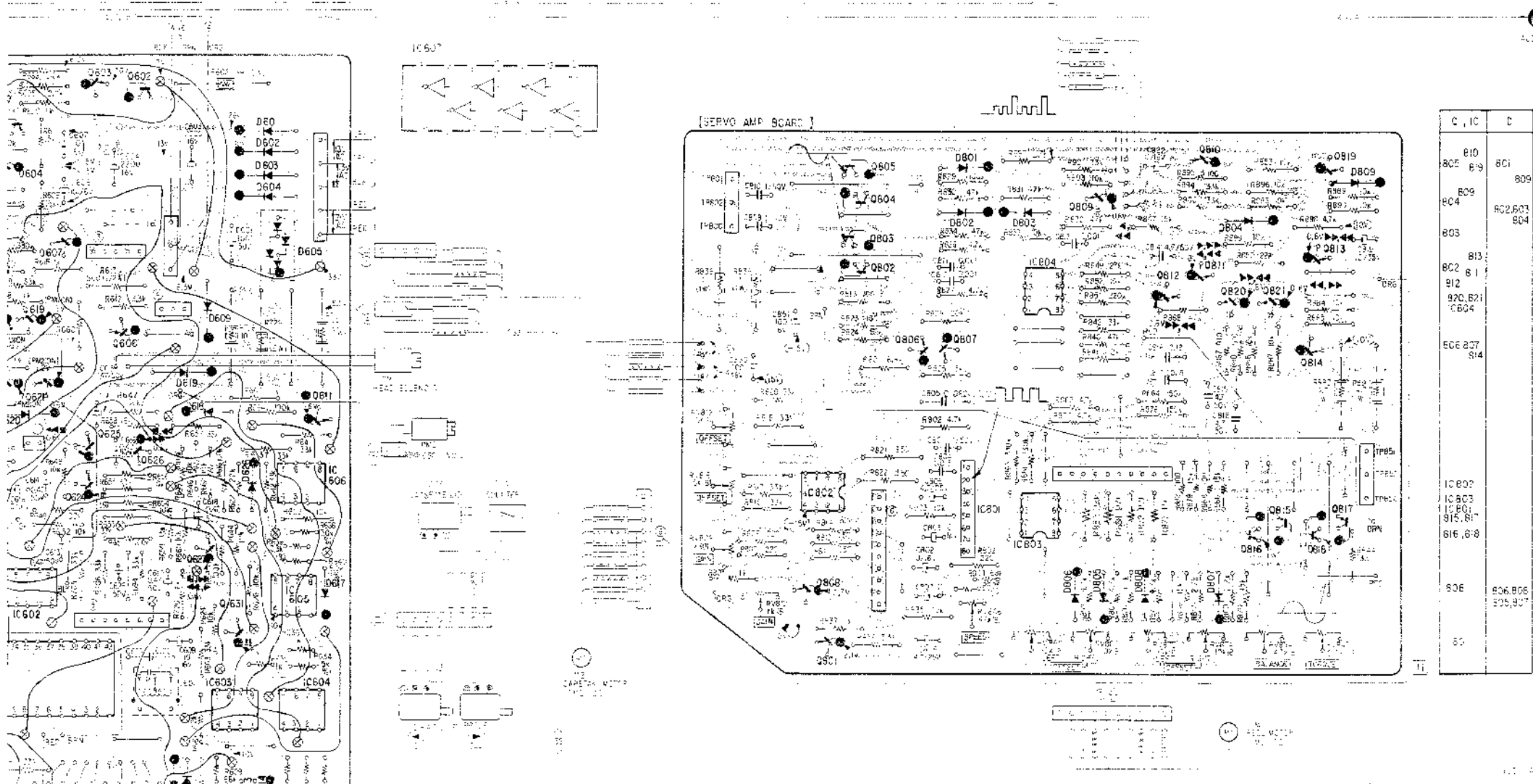

C, IC	D
801	801
802	809
803	803
804	804
805	813
806	811
807	812
808	821
809	804
810	827
811	814
812	802
813	803
814	803
815	803
816	808
817	806
818	806
819	806
820	806
821	806
822	806
823	806
824	806
825	806
826	806
827	806
828	806
829	806
830	806
831	806
832	806
833	806
834	806
835	806
836	806
837	806
838	806
839	806
840	806
841	806
842	806
843	806
844	806
845	806
846	806
847	806
848	806
849	806
850	806
851	806
852	806
853	806
854	806
855	806
856	806
857	806
858	806
859	806
860	806
861	806
862	806
863	806
864	806
865	806
866	806
867	806
868	806
869	806
870	806
871	806
872	806
873	806
874	806
875	806
876	806
877	806
878	806
879	806
880	806
881	806
882	806
883	806
884	806
885	806
886	806
887	806
888	806
889	806
890	806
891	806
892	806
893	806
894	806
895	806
896	806
897	806
898	806
899	806
900	806

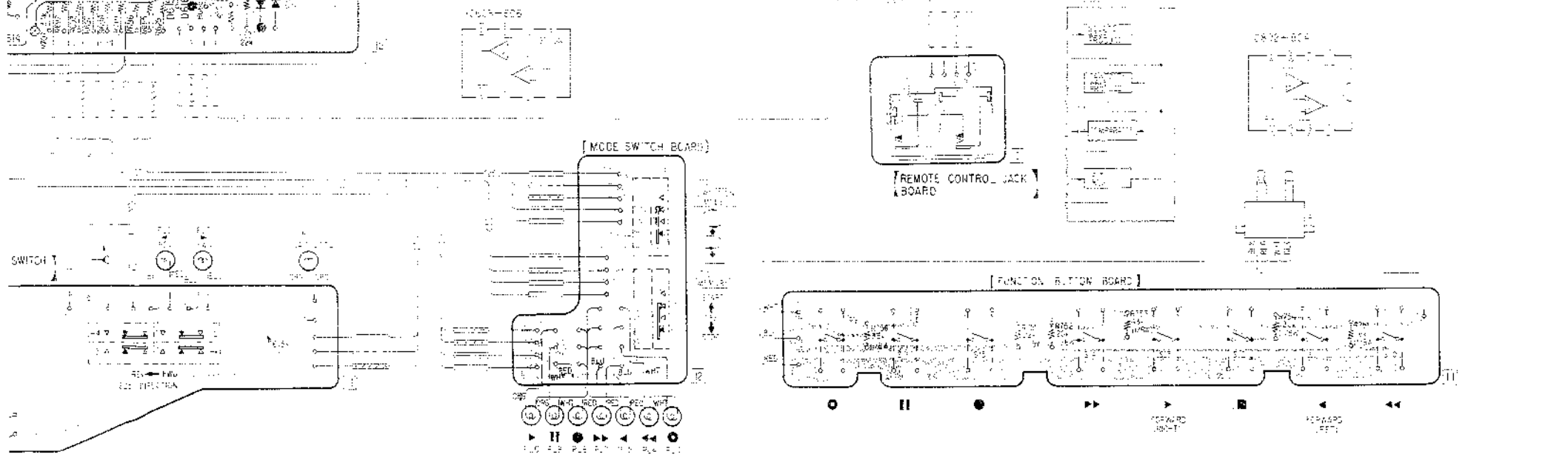

Replacement Semiconductors: See page 4.

- Go to code of sleeving over the end of the jacket.



- : parts extracted from the component's side.
- : parts extracted from the conductor side.
- ⊗ : Through hole.
- ⊙ : component-side pattern
- ⊕ : B + (high) pattern