

TC-FX170

SERVICE MANUAL

US Model
Canadian Model
AEP Model
UK Model
E Model



SPECIFICATIONS

Recording system 4-track 2-channel stereo
Fast winding Approx. 120 sec. (with C-60 cassette)
Bias AC Bias
Signal-to-noise ratio (at peak level)

Cassette	Dolby NR switch		
	OFF	B-TYPE ON	C-TYPE ON
TYPE IV (Sony METAL-SLT/S)	58 dB	66 dB	73 dB
TYPE II (Sony UX-S)	57 dB	65 dB	72 dB
TYPE I (Sony HF-S)	55 dB	63 dB	70 dB

Total harmonic distortion
1.0% (with Sony METAL-SLT/S
cassettes)

Frequency response (DOLBY NR OFF)

TYPE IV cassette (Sony METAL-SLT/S)	30–15,000 Hz (± 3 dB, IEC) 30–13,000 Hz [± 3 dB 0VU (–4 dB) recording]
TYPE II cassette (Sony UX-S)	30–14,000 Hz (± 3 dB, IEC)
TYPE I cassette (Sony HF-S)	30–13,000 Hz (± 3 dB, IEC)

Wow and flutter $\pm 0.16\%$ W, Peak (IEC)
0.11% WRMS (NAB)
 $\pm 0.2\%$ W Peak (DIN)

Dolby noise reduction manufactured under license from
Dolby Laboratories Licensing Corporation.
"DOLBY" and the double-D symbol $\square\square$ are trademarks of
Dolby Laboratories Licensing Corporation.

Model Name Using Similar Mechanism	TC-FX120
Tape Transport Mechanism Type	TCM-180VBN3

Inputs

Line inputs (phono jacks)	Sensitivity	77.5 mV
	Input impedance	47k ohms

Outputs

Line outputs (phono jacks)	Rated output level	0.32 V at a load impedance of 47k ohms
	Load impedance	Over 10k ohms
Headphone output (stereo phone jack)	Output level	0.2 mW at a load impedance of 32 ohms

General

Power requirements

US, Canadian Model:
120 V AC, 60 Hz
AEP Model:
220 V AC, 50/60 Hz
UK Model:
240 V AC, 50 Hz
E Model:
110 – 220 V AC, 220 – 240 V
AC, 50/60 Hz

STEREO CASSETTE DECK
SONY[®]

Power consumption 14 W
 Dimensions Approx. 430 × 123 × 286 mm (w/h/d)
 (17 × 4⁷/₈ × 11³/₈ inches)
 Weight including projecting parts and controls
 Approx. 3.5 kg (7 lbs 12 oz)

Supplied accessory
 Audio connecting cords (2)

Design and specifications subject to change without notice.

Note
 This appliance conforms with EEC Directive 87/308/EEC regarding interference suppression.

MODEL IDENTIFICATION

- Specification Label Printed on Back Panel -

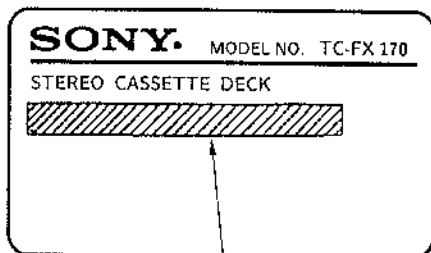

US/Canadian Model : AC 120 V 60 Hz 14 W
 AEP Model : AC 220 - 280 V ~ 50/60 Hz
 UK Model : AC 240 V ~ 50/60 Hz
 E Model : AC 110 - 120 V, 220 - 240 V
 ~ 50/60 Hz 15 W

TABLE OF CONTENTS

<u>Section</u>	<u>Title</u>	<u>Page</u>
Specifications	1
Model Identification	2
1. GENERAL		
	Identification of Front Panel Parts	3
2. ADJUSTMENTS		
2-1.	Mechanical Adjustments	4
2-2.	Electrical Adjustments	4
3. DIAGRAMS		
3-1.	Block Diagram	6
3-2.	Printed Wiring Boards	10
3-3.	Schematic Diagram	13
4. EXPLODED VIEWS		18
5. ELECTRICAL PARTS LIST		22

SAFETY-RELATED COMPONENT WARNING!!

COMPONENTS IDENTIFIED BY MARK OR DOTTED LINE WITH MARK ON THE SCHEMATIC DIAGRAMS AND IN THE PARTS LIST ARE CRITICAL TO SAFE OPERATION. REPLACE THESE COMPONENTS WITH SONY PARTS WHOSE PART NUMBERS APPEAR AS SHOWN IN THIS MANUAL OR IN SUPPLEMENTS PUBLISHED BY SONY.

SAFETY CHECK-OUT

After correcting the original service problem, perform the following safety check before releasing the set to the customer:

Check the antenna terminals, metal trim, "metallized" knobs, screws, and all other exposed metal parts for AC leakage. Check leakage as described below.

LEAKAGE TEST

The AC leakage from any exposed metal part to earth ground and from all exposed metal parts to any exposed metal part having a return to chassis, must not exceed 0.5 mA (500 microamperes). Leakage current can be measured by any one of three methods.

1. A commercial leakage tester, such as the Simpson 229 or RCA WT-540A. Follow the manufacturers' instructions to use these instruments.
2. A battery-operated AC milliammeter. The Data Precision 245 digital multimeter is suitable for this job.
3. Measuring the voltage drop across a resistor by means of a VOM or battery-operated AC voltmeter. The "limit" indication is 0.75 V, so analog meters must have an accurate low-voltage scale. The Simpson 250 and Sanwa SH-63Trd are examples of a passive VOM that is suitable. Nearly all battery operated digital multimeters that have a 2 V AC range are suitable. (See Fig. A)

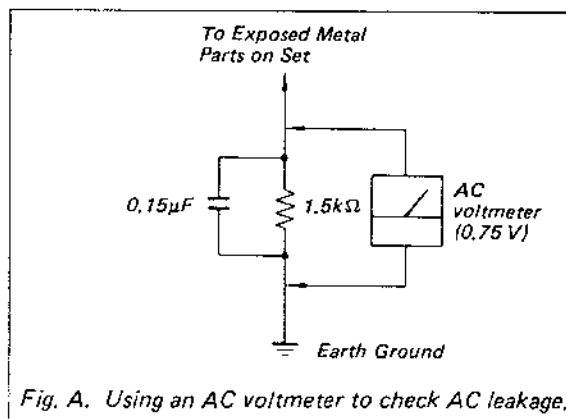

Fig. A. Using an AC voltmeter to check AC leakage.

ATTENTION AU COMPOSANT AYANT RAPPORT À LA SÉCURITÉ

LES COMPOSANTS IDENTIFIÉS PAR UNE MARQUE SUR LES DIAGRAMMES SCHÉMATIQUES ET LA LISTE DES PIÈCES SONT CRITIQUES POUR LA SÉCURITÉ DE FONCTIONNEMENT. NE REMPLACER CES COMPOSANTS QUE PAR DES PIÈCES SONY DONT LES NUMÉROS SONT DONNÉS DANS CE MANUEL OU DANS LES SUPPLÉMENTS PUBLIÉS PAR SONY.

SECTION 1 GENERAL

Identification of Front Panel Parts

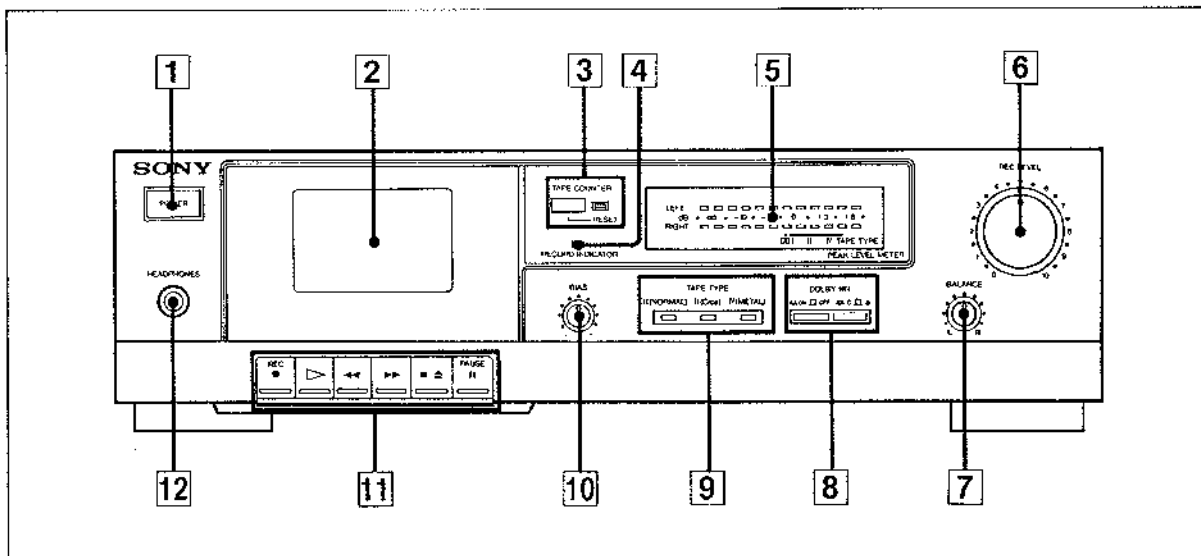

- | | |
|--|--|
| 1 POWER switch | 9 TAPE TYPE indicators |
| 2 Cassette holder | 10 BIAS control |
| 3 TAPE COUNTER and RESET button | 11 Tape operation buttons <ul style="list-style-type: none"> ● REC (record) button ▶ (play) button ◀◀ (rewind) button ▶▶ (fast-forward) button ■▲ (stop) and (eject) buttons PAUSE button |
| 4 RECORD INDICATOR | |
| 5 PEAK LEVEL METER | |
| 6 REC (recording) LEVEL control | |
| 7 BALANCE control | 12 HEADPHONES jack (stereo phone jack) |
| 8 DOLBY NR (Dolby Noise Reduction) buttons | |

SECTION 2 ADJUSTMENTS

2-1. MECHANICAL ADJUSTMENTS

PRECAUTION

1. Clean the following parts with a denatured-alcohol-moistened swab:

record/playback head	pinch roller
erase head	rubber belts
capstan	idler
2. Demagnetize the record/playback head with a head demagnetizer.
3. Do not use a magnetized screwdriver for the adjustments.
4. After the adjustments, apply suitable locking compound to the parts adjusted.
5. The adjustments should be performed with the rated power supply voltage unless otherwise noted.

Torque Measurement

Torque	Torque	Meter reading
FWD	CQ-102C	30 to 70 g·cm (0.43 to 0.97 oz·inch)
FWD Back tension	CQ-102C	1.5 to 6 g·cm (0.02 to 0.07 oz·inch)
FF, REW	CQ-201B	63 g·cm or more (0.87 oz·inch or more)

2-2. ELECTRICAL ADJUSTMENTS

Note: The adjustment should be performed in the order given in this service manual.
The adjustments should be performed for both L-CH and R-CH.

- Switches and controls should be set as follows unless otherwise specified.
DOLBY NR switch: OFF
- Standard Record:
Deliver the standard input signal level to the input jack and set the REC LEVEL control to obtain the standard output signal level.

— Record Mode —

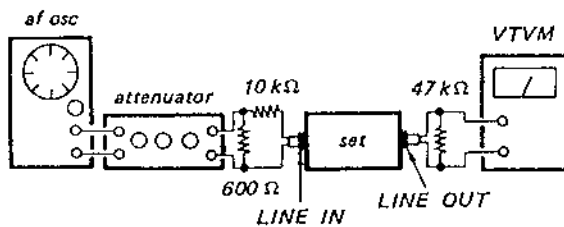

Standard Input Level

	LINE IN
source impedance	10 kΩ
input level	0.5 V (− 3.8 dBs)

Standard Output Level

	LINE OUT
load impedance	47 kΩ
output level	0.5 V (− 3.8 dBs)

Capstan Motor Speed Adjustment

Procedure:

Mode: playback

test tape
WS-48A
(3kHz, 0dB)

speed checker
LFM-30
or
digital frequency
counter

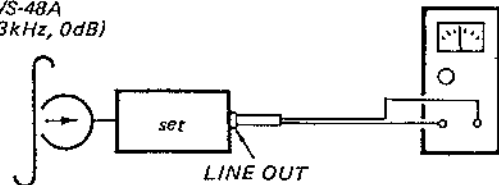

Specification:

Speed checker	Digital frequency counter
−0.3 ~ +0.3%	2,990 ~ 3,010 Hz

Frequency difference between the beginning and the end of the tape should be within 0.3% (10 Hz).

Adjustment Location

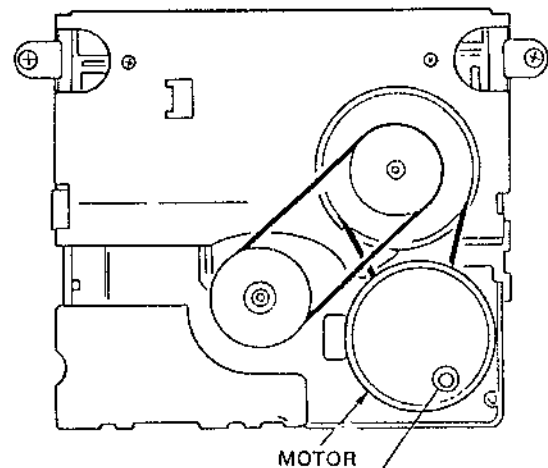

Adjust the speed by using screwdriver. When turning the screw clockwise, speed is faster.

Record/Playback Head Azimuth Adjustment

Procedure:

1. Mode: playback

test tape
P-4-A063
(6.3kHz, -10dB)

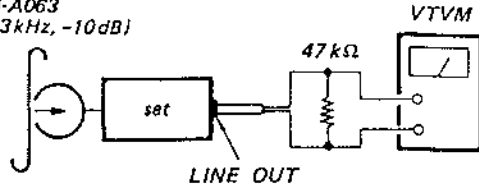

2. Turn the adjustment screw for the maximum output levels. If these levels do not match, turn the adjustment screw until both of output levels match together within 1 dB.

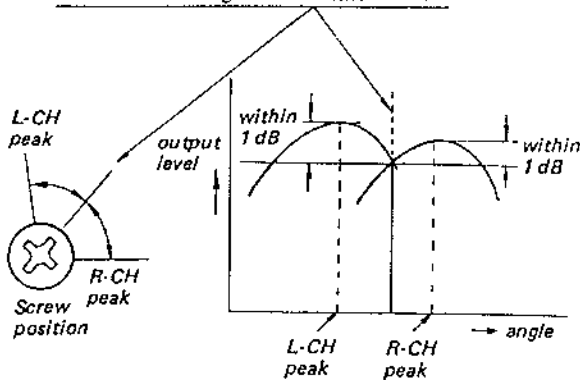

3. Phase Check
Mode: playback

test tape
P-4-063
(6.3kHz, -10dB)

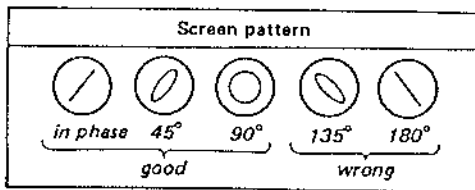
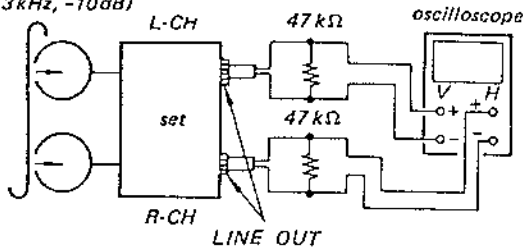

Adjustment Location:

— Record/Playback head —

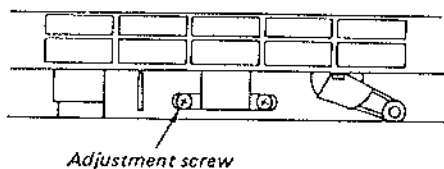

Playback Level Adjustment

Procedure:

1. Mode: playback

test tape
P-4-L300
(315Hz, 0dB)

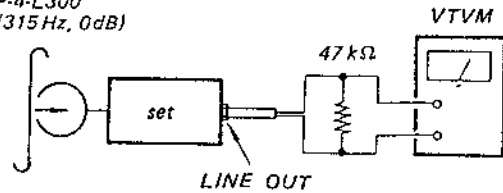

Adjust RV102 (L-CH) and RV202 (R-CH) so that the specification is met.

Specification:

Line OUT level: $-7.7 \text{ dB} \pm 0.5 \text{ dB}$

Level difference between channels:
less than 0.5 dB

Check that the LINE OUT level does not change in playback mode while changing the mode from playback to stop several times.

Record Bias Adjustment

Setting:

REC LEVEL control: standard record

Procedure:

1. Mode: record

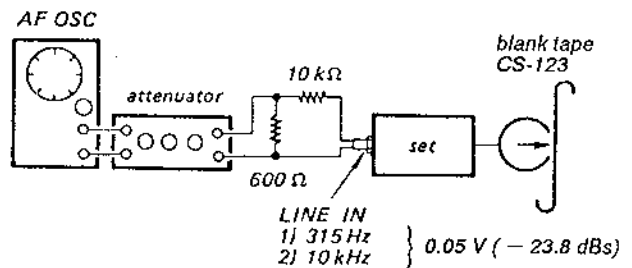

2. Mode: playback

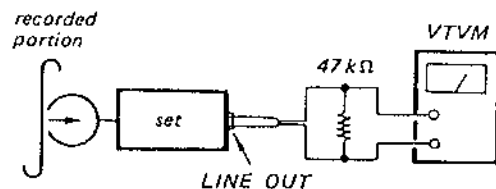

Confirm that the 10 kHz playback output is $0 \pm 0.5 \text{ dB}$ relative to the 315 Hz output. If necessary, adjust CT-301-1 (L-CH), CT301-2 (R-CH) and repeat the steps given above.

SECTION 3 DIAGRAMS

3-1. BLOCK DIAGRAM

Record Level Adjustment

Setting:
REC LEVEL control: standard record

Procedure:

1. Mode: record

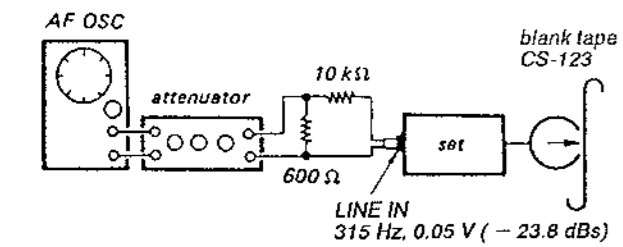

2. Mode: playback

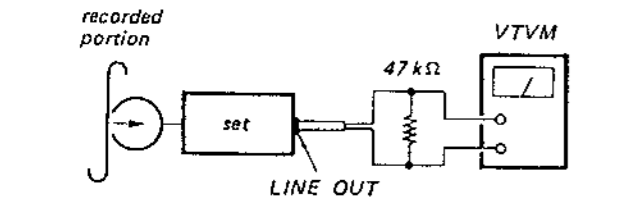

3. Playback the signal recorded in step 1. Confirm that the signal level is within the specification below. If necessary, adjust RV101 (L-CH), RV201 (R-CH) and repeat the step 1-3.

Specification:

LINE OUT level: -23.8 dBs ± 0.5 dB

Adjustment Location: audio board

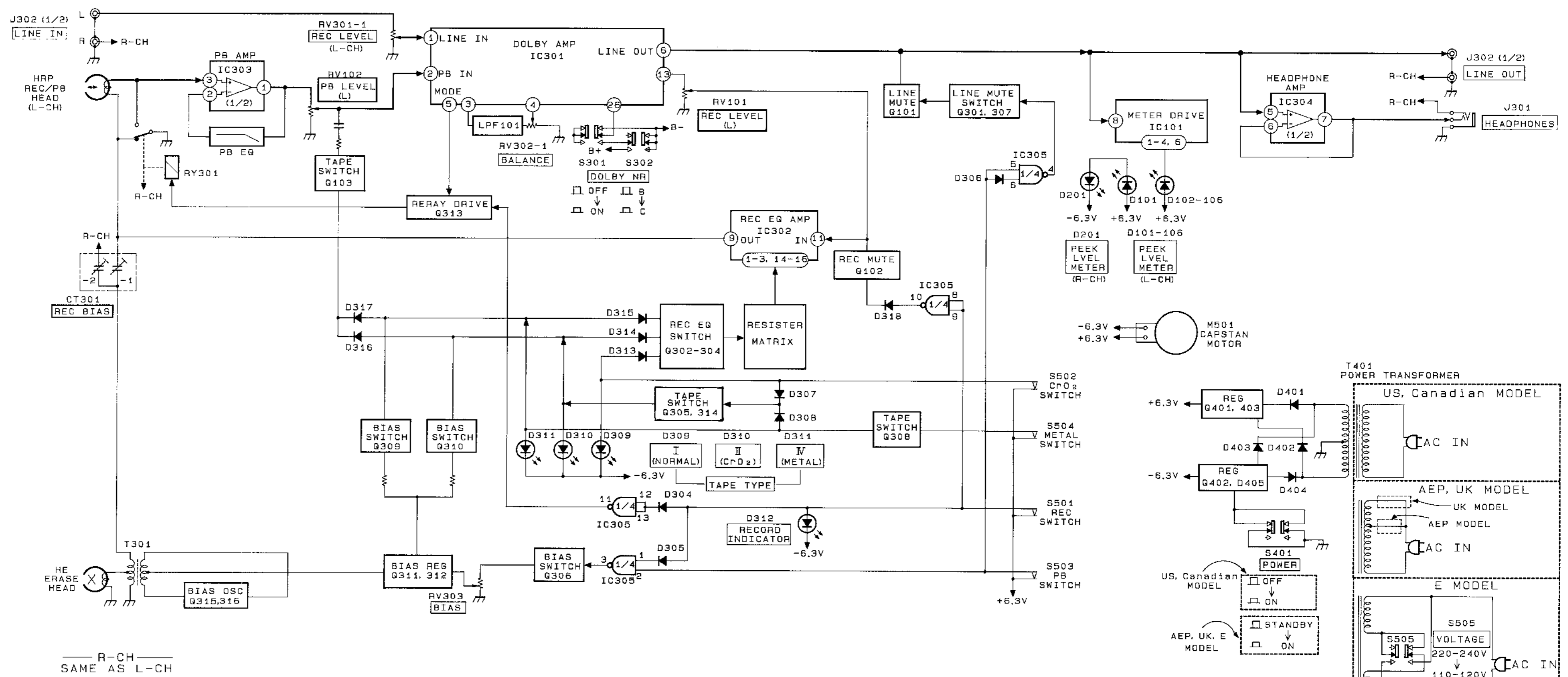
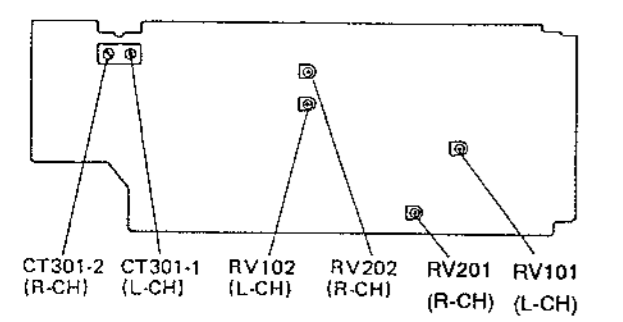

R-CH
SAME AS L-CH

• Semiconductor Lead Layouts

DTA114ES
DTA144ES
DTC114ES
DTC143TS
2SC2603-EF



2SA1175-HFE



2SB1094-L
2SD2012

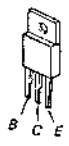

2SC945-P



10E2N

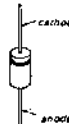

SEL1210S-C

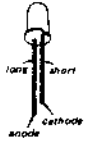

SEL4214S-C

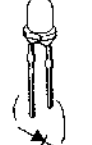

SEL4414E-C

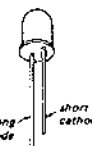

1SS120
UZL-7L3

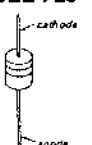

• Semiconductor Location

Ref. No.	Location
D101	E-7
D102	E-8
D103	E-8
D104	E-9
D105	E-9
D106	E-10
D201	D-7
D202	D-8
D203	D-8
D204	D-9
D205	D-9
D206	D-10
D301	B-12
D302	C-7
D303	C-6
D304	D-7
D305	E-7
D306	E-6
D307	C-7
D308	C-7
D309	C-7
D310	C-7
D311	C-8
D312	D-5
D313	E-10
D314	E-9
D315	E-10
D316	D-8
D317	D-8
D318	E-11
D319	G-5
D401	G-6
D402	G-6
D403	G-6
D404	G-6
D405	G-6
IC101	E-9
IC201	D-10
IC301	C-13
IC302	E-12
IC303	B-8
IC304	H-4
IC305	E-7
Q101	B-11
Q102	E-12
Q103	B-14
Q201	B-10
Q202	E-12
Q203	B-13
Q301	B-10
Q302	E-10
Q303	E-10
Q304	E-10
Q305	D-8
Q306	C-7
Q307	B-10
Q308	C-7
Q309	C-6
Q310	C-5
Q311	C-5
Q312	C-5
Q313	D-7
Q314	D-8
Q315	D-4
Q316	D-4
Q401	G-5
Q402	H-5
Q403	G-5

Note:
 • : parts extracted from the component side.
 • : indicates side identified with part number.

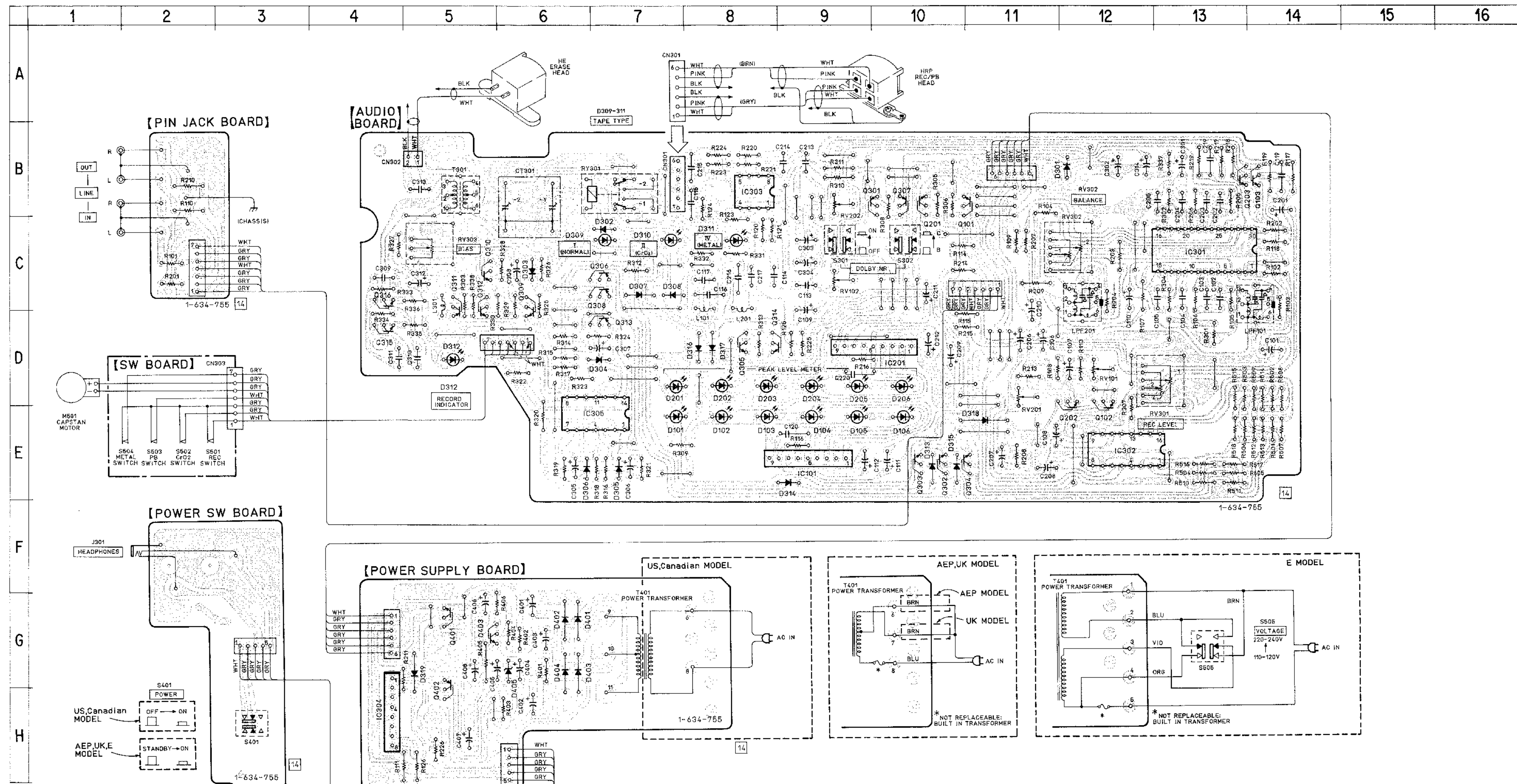

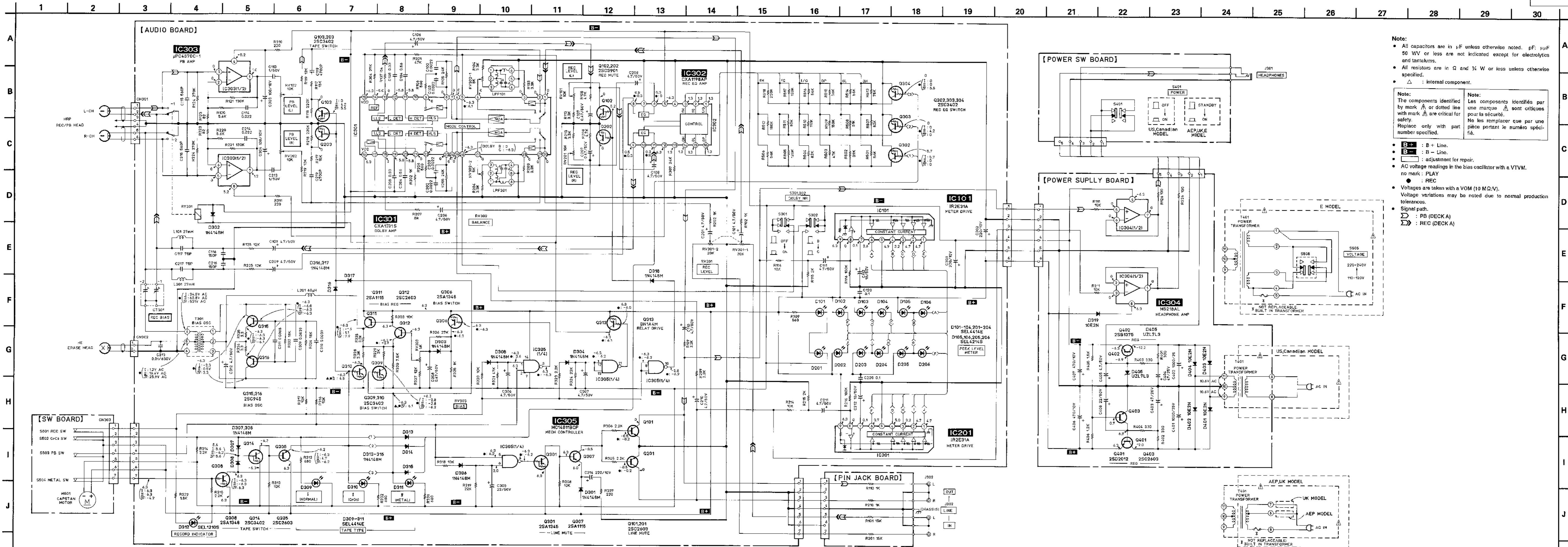

Note:

- All capacitors are in μF unless otherwise noted. μF : μF 50 WV or less are not indicated except for electrolytics and tantalums.
- All resistors are in Ω and $\frac{1}{4}$ W or less unless otherwise specified.
- Δ : internal component.

Note:

The components identified by mark Δ or dotted line with mark Δ are critical for safety. Replace only with part number specified.

Note:

Les composants identifiés par une marque Δ sont critiques pour la sécurité. Ne les remplacer que par une pièce portant le numéro spécifié.

- $B+$: B+ Line.
- $B-$: B- Line.
- \square : adjustment for repair.
- AC voltage readings in the bias oscillator with a VTVM. no mark: PLAY
- \bullet : taken
- Voltages are taken with a VOM (10 M Ω/V). Voltage variations may be noted due to normal production tolerances.
- Signal path.
- \square : PB (DECK A)
- \square : REC (DECK A)

SECTION 5 EXPLODED VIEWS

NOTE:

- -XX and -X mean standardized parts, so they may have some difference from the original one.

- Color Indication of Appearance Parts

Example:

KNOB, BALANCE (WHITE) ... (RED)

↑ Parts Color ↑ Cabinet's Color

- Items marked "*" are not stocked since they are seldom required for routine service. Some delay should be anticipated when ordering these items.

- The mechanical parts with no reference number in the exploded views are not supplied.

- Hardware (# mark) list is given in the last of this parts list.

The components identified by mark or dotted line with mark are critical for safety. Replace only with part number specified.

Les composants identifiés par une marque sont critiques pour la sécurité. Ne les remplacer que par une pièce portant le numéro spécifié.

(1) CABINET AND FRONT PANEL SECTION

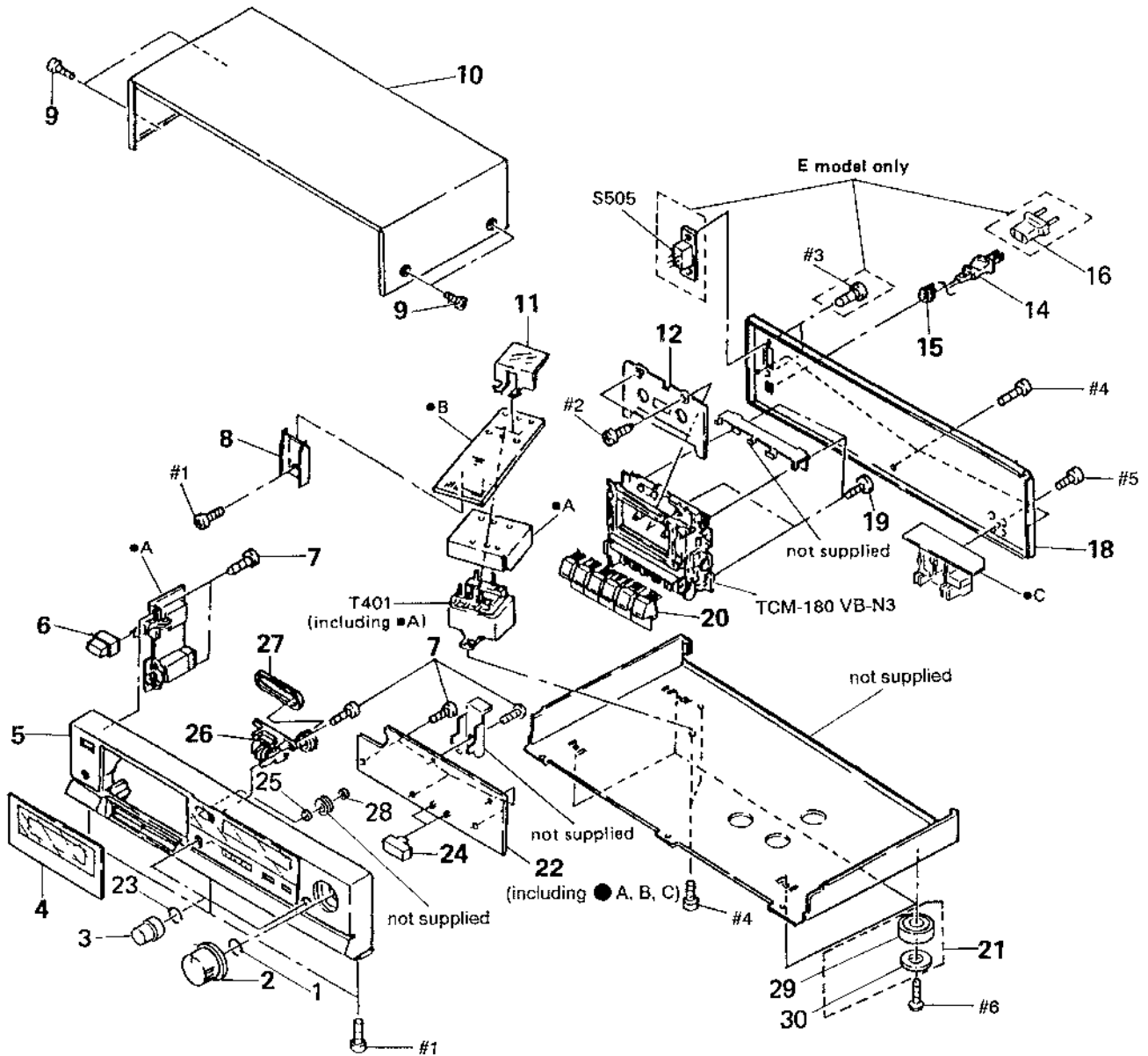

Ref. No.	Part No.	Description	Remark
1	3-350-426-01	SPRING	
2	3-367-438-12	KNOB (REC)	
3	3-367-431-01	KNOB (BAL)	
4	X-3362-657-1	LID ASSY, CASSETTE	
5	A-2003-854-A	PANEL ASSY, FRONT (AEP, UK, E)	
5	X-3362-658-1	PANEL ASSY, FRONT (US, Canadian)	
6	4-917-460-01	KNOB, POWER (MADE IN MALAYSIA)	
6	3-354-912-01	KNOB, POWER (MADE IN JAPAN)	
7	4-928-635-01	SCREW, +BV (2.6X8) TAPPING	
8	* 3-309-144-21	HEAT SINK	
9	3-704-366-01	SCREW (CASE) (M3X8)	
10	4-943-088-31	CASE (MADE IN MALAYSIA)	
10	3-332-578-42	CASE (MADE IN JAPAN)	
11	* 3-327-872-01	COVER (TRANSFORMER)	
12	X-3358-214-1	PLATE ASSY, ORNAMENTAL	
14	△· 1-551-506-XX	CORD, POWER (US, Canadian) (MADE IN JAPAN)	
14	△· 1-551-884-32	CORD, POWER (UK) (MADE IN MALAYSIA)	
14	△· 1-551-908-11	CORD, POWER (AEP) (MADE IN MALAYSIA)	
14	△· 1-551-188-XX	CORD, POWER (E) (MADE IN MALAYSIA)	
14	△· 1-551-628-12	CORD, POWER (US, Canadian) (MADE IN MALAYSIA)	
15	* 3-703-571-11	BUSHING (S) (4516), CORD (US, Canadian, E)	
15	* 3-703-244-02	BUSHING (S) (4516), CORD (AEP, UK)	
16	△· 1-569-007-11	ADAPTOR CONNECTION 2P (E)	

Ref. No.	Part No.	Description	Remark
18	* 3-367-318-32	PANEL, BACK (UK) (MADE IN MALAYSIA)	
18	* 3-367-318-42	PANEL, BACK (E) (MADE IN MALAYSIA)	
18	* 3-367-318-22	PANEL, BACK (AEP) (MADE IN MALAYSIA)	
18	* 3-367-318-01	PANEL, BACK (US, Canadian) (MADE IN MALAYSIA)	
18	* 3-366-413-01	PANEL, BACK (US) (MADE IN JAPAN)	
19	4-928-635-21	SCREW, +BV (2.6X10) TAPPING	
20	3-366-411-01	BUTTON (BLOCK)	
21	X-4885-950-1	FOOT ASSY (US) (MADE IN JAPAN)	
22	* A-2006-547-A	AUDIO BOARD, COMPLETE (MADE IN MALAYSIA)	
22	* A-2006-427-A	AUDIO BOARD, COMPLETE (MADE IN JAPAN) (INCLUDING A, B, C)	
23	3-356-957-01	SPRING	
24	3-350-810-01	BUTTON	
25	3-701-437-11	WASHER	
26	1-548-596-61	COUNTER, TAPE (MIDDLE TYPE)	
27	3-527-150-XX	BELT, CAPSTAN	
28	3-558-708-11	WASHER, STOPPER	
29	3-318-688-31	FOOT (F58175 S) (AEP, UK, E) (MADE IN MALAYSIA)	
29	3-318-688-51	FOOT (F58175 S) (US, Canadian) (MADE IN MALAYSIA)	
30	4-923-836-11	CUSHION	
S505	△· 1-552-535-00	SWITCH, POWER & VOLTAGE CHANGE (E)	
T401	△· 1-449-593-11	TRANSFORMER, POWER (US, Canadian)	
T401	△· 1-449-388-11	TRANSFORMER, POWER (E)	
T401	△· 1-450-442-21	TRANSFORMER, POWER (AEP, UK)	

Note:
The components identified by mark △ or dotted line with mark △ are critical for safety. Replace only with part number specified.

Note:
Les composants identifiés par une marque △ sont critiques pour la sécurité. Ne les remplacer que par une pièce portant le numéro spécifié.

(2) MECHANISM SECTION-1
(TCM-180VB-N3)

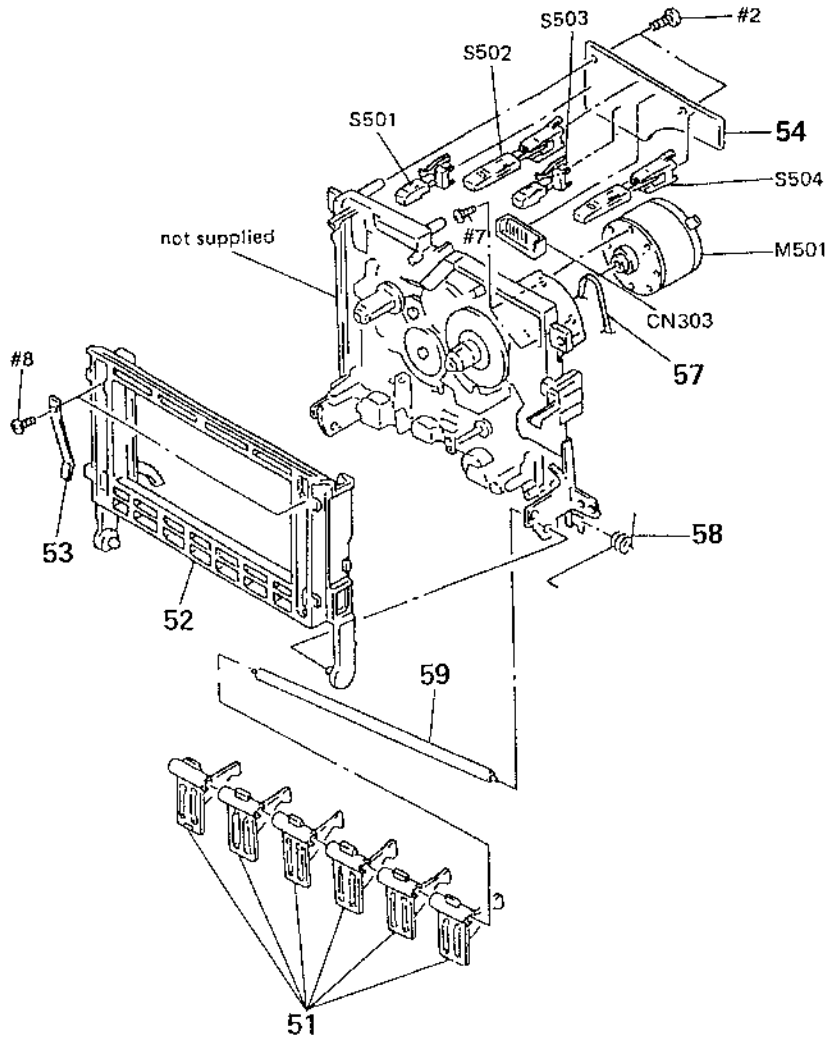

Ref. No.	Part No.	Description	Remark
51	3-358-271-01	LEVER (BUTTON BASE A)	
52	3-358-266-02	HOLDER, CASSETTE	
53	3-358-209-01	SPRING (CASSETTE HOLDER), LEAF	
54	* 1-635-160-11	PC BOARD, SWITCH	
57	3-358-230-01	BELT (A1)	
58	3-358-287-01	SPRING (LOADING A), TORSION	
59	3-358-242-01	SHAFT (BUTTON SHAFT)	
M501	X-3358-211-1	MOTOR (A) ASSY	

(3) MECHANISM SECTION-2
(TCM-180VB-N3)

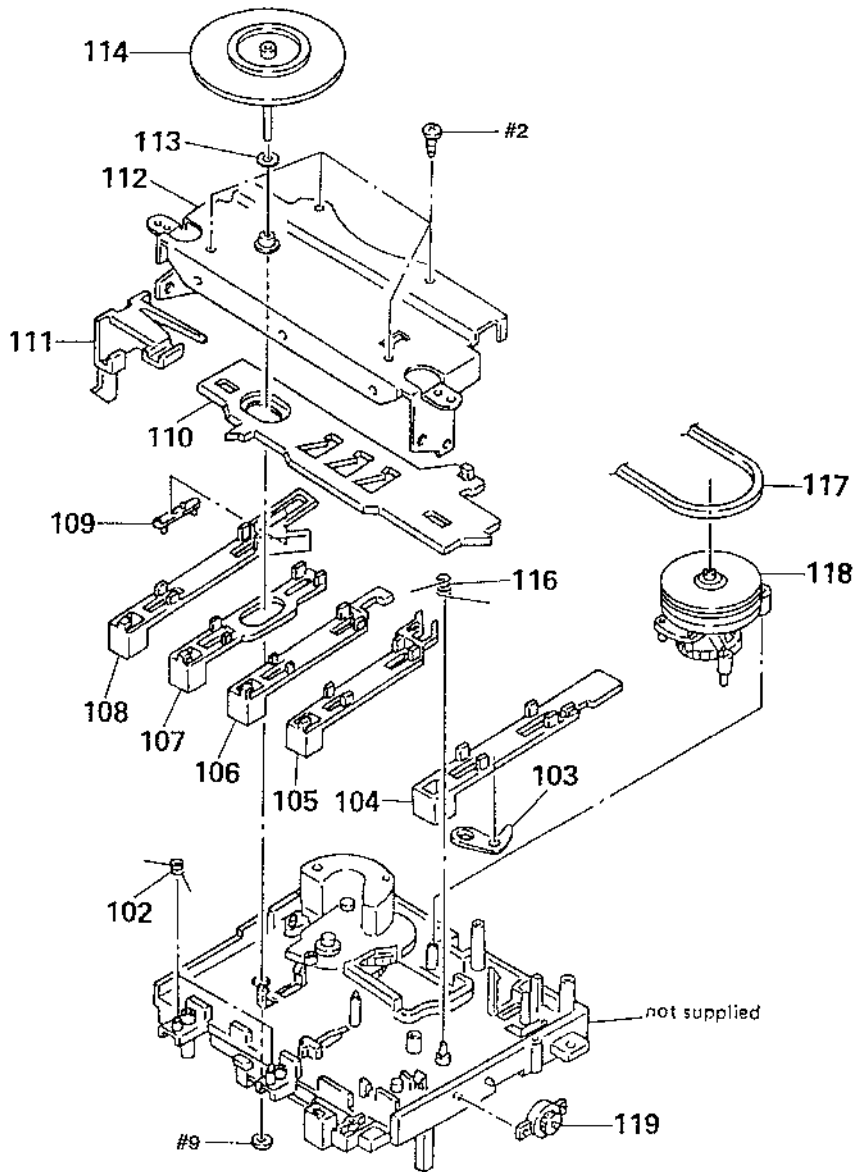

Ref. No.	Part No.	Description	Remark	Ref. No.	Part No.	Description	Remark
102	3-358-232-01	SPRING (S-P F-R). TORSION		111	* 3-358-261-02	SLIDER (HOLDER LOCK)	
103	* 3-358-204-01	LEVER (REC SAFETY)		112	* X-3358-213-1	BRACKET (A) ASSY	
104	3-358-259-01	SLIDER (REC)		113	3-701-437-01	WASHER	
105	3-358-258-01	SLIDER (REW)		114	X-3358-205-1	FLYWHEEL ASSY	
106	3-358-257-01	SLIDER (FF)		116	3-358-233-01	SPRING (REC-LOCK). TORSION	
107	3-358-256-01	SLIDER (STOP/EJECT)		117	3-358-230-01	BELT (A1)	
108	3-358-260-01	SLIDER (PAUSE)		118	X-3358-202-1	LEVER (FR ARM) ASSY	
109	* 3-358-226-01	LEVER (PAUSE LEVER)		119	3-319-224-31	DAMPER, SMALL	
110	* 3-358-249-01	SLIDER (LOCK PLATE)					

(4) MECHANISM SECTION-3
(TCM-180VB-N3)

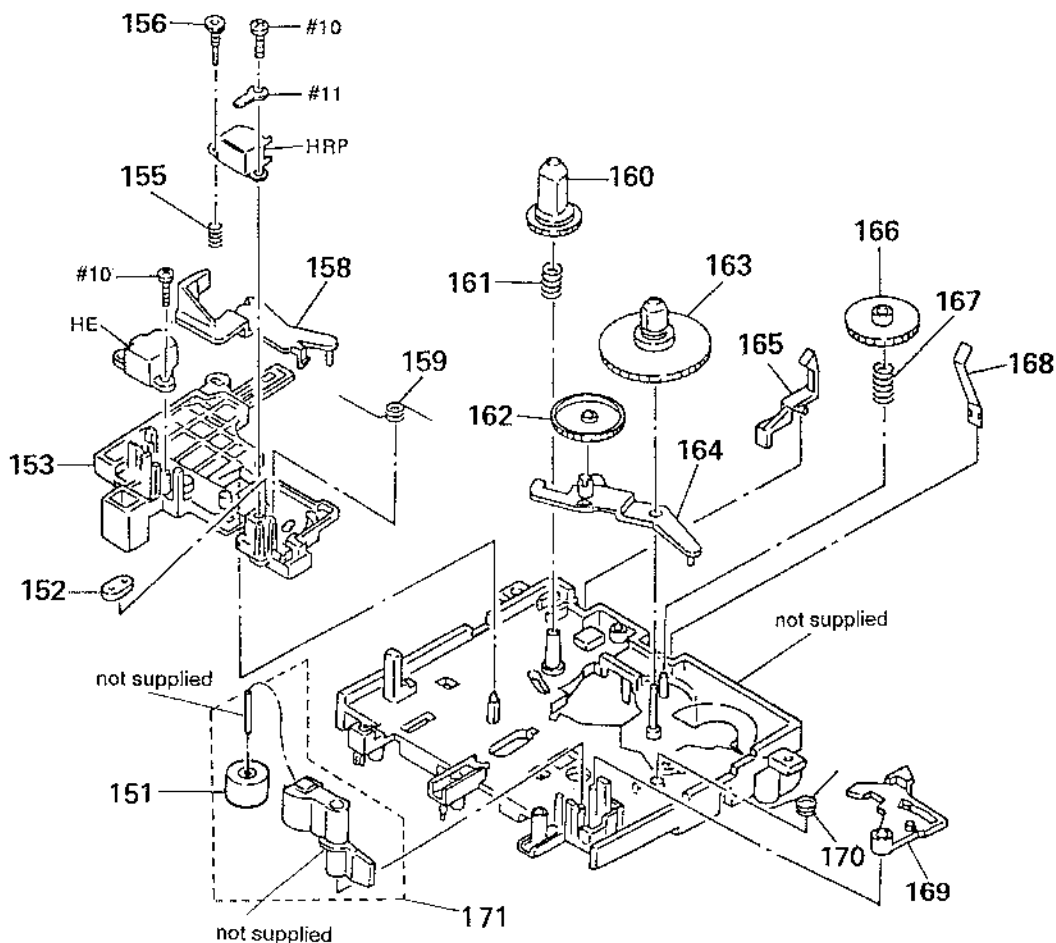

Ref. No.	Part No.	Description	Remark	Ref. No.	Part No.	Description	Remark
151	3-578-143-11	PINCH ROLLER		163	X-3358-203-1	TABLE (T) ASSY. REEL	
152	* 3-358-215-01	BUSHING (WIRE KIT RETAINER)		164	* 3-358-252-01	LEVER (TU ARM)	
153	3-358-265-01	SLIDER (HEAD PC BOARD A)		165	* 3-358-255-01	LEVER (GB LEVER)	
155	3-358-234-01	SPRING (AZIMUTH), COMPRESSION		166	* 3-358-224-01	GEAR (FF GEAR)	
156	3-358-288-01	SCREW (T), AZIMUTH		167	3-358-207-01	SPRING (FF GEAR), COMPRESSION	
158	* 3-358-251-01	LEVER (TENSION DETECTION ARM)		168	3-358-227-01	SPRING, LEAF	
159	3-358-228-01	SPRING, TORSION		169	* 3-358-253-01	LEVER (SHUT-OFF LEVER)	
160	3-358-248-01	GEAR (SUPPLY REEL)		170	3-358-243-01	SPRING (TU-SHUT), TORSION	
161	3-358-208-01	SPRING (SUPPLY), COMPRESSION		171	X-3358-204-1	LEVER (PINCH LEVER) ASSY	
162	* 3-358-284-01	GEAR (TU GEAR)		HE	1-543-673-11	HEAD, MAGNETIC (ERASE)	
				HRP	1-543-319-11	HEAD, MAGNETIC (REC/PB)	

SECTION 6 ELECTRICAL PARTS LIST

AUDIO
PIN JACK
POWER SW
POWER SUPPLY

NOTE:

- Due to standardization, replacements in the parts list may be different from the parts specified in the diagrams or the components used on the set.
- -XX and -X mean standardized parts, so they may have some difference from the original one.
- **RESISTORS**
All resistors are in ohms.
METAL: Metal-film resistor
METAL OXIDE: Metal Oxide-film resistor
F: nonflammable
- Items marked "*" are not stocked since they are seldom required for routine service. Some delay should be anticipated when ordering these items.
- **SEMICONDUCTORS**
In each case, u: μ , for example:
uA...: μ A..., uPA...: μ PA...,
uPB...: μ PB..., uPC...: μ PC...,
uPD...: μ PD...
- **CAPACITORS**
uF: μ F
- **COILS**
uH: μ H

The components identified by mark Δ or dotted line with mark Δ are critical for safety. Replace only with part number specified.

Les composants identifiés par une marque Δ sont critiques pour la sécurité. Ne les remplacer que par une pièce portant le numéro spécifié.

Ref. No.	Part No.	Description	Remark	Ref. No.	Part No.	Description	Remark
<p>* A-2006-547-A AUDIO BOARD, COMPLETE (MADE IN MALAYSIA) (INCLUDING PIN JACK BOARD, POWER SW BOARD, POWER SUPPLY BOARD) *****</p>				C207	1-124-902-00	ELECT	0.47uF 20% 50V
<p>* 3-309-144-21 HEAT SINK 7-682-547-04 SCREW +BVTT 3X6 (S)</p>				C208	1-124-927-11	ELECT	4.7uF 20% 100V
<p>< CAPACITOR ></p>				C209	1-124-927-11	ELECT	4.7uF 20% 100V
C101	1-124-927-11	ELECT	4.7uF 20% 100V	C210	1-124-927-11	ELECT	4.7uF 20% 100V
C102	1-130-475-00	MYLAR	0.0022uF 5% 50V	C211	1-124-927-11	ELECT	4.7uF 20% 100V
C103	1-130-475-00	MYLAR	0.0022uF 5% 50V	C212	1-124-907-11	ELECT	10uF 20% 50V
C104	1-136-174-00	FILM	0.56uF 5% 50V	C213	1-124-611-00	ELECT	1uF 20% 50V
C105	1-136-171-00	FILM	0.33uF 5% 50V	C214	1-136-157-00	FILM	0.022uF 5% 50V
C106	1-124-927-11	ELECT	4.7uF 20% 100V	C215	1-162-291-31	CERAMIC	560PF 10% 50V
C107	1-124-902-00	ELECT	0.47uF 20% 50V	C216	1-162-284-31	CERAMIC	150PF 10% 50V
C108	1-124-927-11	ELECT	4.7uF 20% 100V	C217	1-136-273-91	FILM	75PF 5% 630V
C109	1-124-927-11	ELECT	4.7uF 20% 100V	C219	1-161-377-00	CERAMIC	0.0047uF 30% 16V
C110	1-124-927-11	ELECT	4.7uF 20% 100V	C220	1-164-159-11	CERAMIC	0.1uF 50V
C111	1-124-927-11	ELECT	4.7uF 20% 100V	C301	1-126-176-11	ELECT	220uF 20% 10V
C112	1-124-907-11	ELECT	10uF 20% 50V	C302	1-126-176-11	ELECT	220uF 20% 10V
C113	1-124-611-00	ELECT	1uF 20% 50V	C303	1-124-443-00	ELECT	100uF 20% 10V
C114	1-136-157-00	FILM	0.022uF 5% 50V	C304	1-124-443-00	ELECT	100uF 20% 10V
C115	1-162-291-31	CERAMIC	560PF 10% 50V	C305	1-126-233-11	ELECT	22uF 20% 50V
C116	1-162-284-31	CERAMIC	150PF 10% 50V	C306	1-124-927-11	ELECT	4.7uF 20% 100V
C117	1-136-273-91	FILM	75PF 5% 630V	C307	1-124-927-11	ELECT	4.7uF 20% 100V
C119	1-161-377-00	CERAMIC	0.0047uF 30% 16V	C308	1-124-902-00	ELECT	0.47uF 20% 50V
C120	1-164-159-11	CERAMIC	0.1uF 50V	C309	1-130-478-00	MYLAR	0.0039uF 5% 50V
C201	1-124-927-11	ELECT	4.7uF 20% 100V	C310	1-130-478-00	MYLAR	0.0039uF 5% 50V
C202	1-130-475-00	MYLAR	0.0022uF 5% 50V	C311	1-130-481-00	MYLAR	0.0068uF 5% 50V
C203	1-130-475-00	MYLAR	0.0022uF 5% 50V	C312	1-124-927-11	ELECT	4.7uF 20% 100V
C204	1-136-174-00	FILM	0.56uF 5% 50V	C313	1-136-601-11	FILM	0.01uF 5% 630V
C205	1-136-171-00	FILM	0.33uF 5% 50V	C314	1-126-176-11	ELECT	220uF 20% 10V
C206	1-124-927-11	ELECT	4.7uF 20% 100V	C401	1-124-557-11	ELECT	1000uF 20% 25V
				C402	1-124-557-11	ELECT	1000uF 20% 25V
				C403	1-124-477-11	ELECT	47uF 20% 25V
				C404	1-124-477-11	ELECT	47uF 20% 25V
				C405	1-124-927-11	ELECT	4.7uF 20% 100V
				C406	1-124-472-11	ELECT	470uF 20% 10V
				C407	1-124-472-11	ELECT	470uF 20% 10V
				C408	1-126-233-11	ELECT	22uF 20% 50V

AUDIO

PIN JACK

POWER SW

POWER SUPPLY

Ref. No.	Part No.	Description	Remark	Ref. No.	Part No.	Description	Remark
		< CONNECTOR >				< IC >	
CN301	* 1-564-509-11	PLUG, CONNECTOR 6P		IC101	8-759-917-42	IC IR2E31A	
CN302	* 1-564-505-11	PLUG, CONNECTOR 2P		IC201	8-759-917-42	IC IR2E31A	
		< TRIMMER >		IC301	8-752-035-94	IC CXA1331S	
CT301	1-141-225-00	CAP, TUNING, TRIMAR		IC302	8-752-036-02	IC CXA1198AP	
		< DIODE >		IC303	8-759-111-44	IC uPC4570C-1	
D101	8-719-304-37	DIODE SEL4414E-C		IC304	8-759-634-50	IC M5218AL	
D102	8-719-304-37	DIODE SEL4414E-C		IC305	8-759-140-11	IC uPD4011BC	
D103	8-719-304-37	DIODE SEL4414E-C				< JACK >	
D104	8-719-304-37	DIODE SEL4414E-C		J301	1-507-981-11	JACK (LARGE TYPE) (HEADPHONES)	
D105	8-719-304-32	DIODE SEL4214S-C		J302	1-565-259-11	JACK, PIN 4P (LINE IN/OUT)	
D106	8-719-304-32	DIODE SEL4214S-C				< COIL >	
D201	8-719-304-37	DIODE SEL4414E-C		L101	1-410-780-11	INDUCTOR 27mH	
D202	8-719-304-37	DIODE SEL4414E-C		L201	1-410-780-11	INDUCTOR 27mH	
D203	8-719-304-37	DIODE SEL4414E-C		L301	1-410-976-11	INDUCTOR 68uH	
D204	8-719-304-37	DIODE SEL4414E-C				< FILTER >	
D205	8-719-304-32	DIODE SEL4214S-C		LPF101	1-236-087-11	FILTER, LOW PASS	
D206	8-719-304-32	DIODE SEL4214S-C		LPF201	1-236-087-11	FILTER, LOW PASS	
D301	8-719-912-20	DIODE 1SS120				< TRANSISTOR >	
D302	8-719-912-20	DIODE 1SS120		Q101	8-729-620-05	TRANSISTOR 2SC2603-EF	
D303	8-719-912-20	DIODE 1SS120		Q102	8-729-900-74	TRANSISTOR DTC143TS	
D304	8-719-912-20	DIODE 1SS120		Q103	8-729-900-80	TRANSISTOR DTC114ES	
D305	8-719-912-20	DIODE 1SS120		Q201	8-729-620-05	TRANSISTOR 2SC2603-EF	
D306	8-719-912-20	DIODE 1SS120		Q202	8-729-900-74	TRANSISTOR DTC143TS	
D307	8-719-912-20	DIODE 1SS120		Q203	8-729-900-80	TRANSISTOR DTC114ES	
D308	8-719-912-20	DIODE 1SS120		Q301	8-729-900-65	TRANSISTOR DTA144ES	
D309	8-719-304-37	DIODE SEL4414E-C		Q302	8-729-900-80	TRANSISTOR DTC114ES	
D310	8-719-304-37	DIODE SEL4414E-C		Q303	8-729-900-80	TRANSISTOR DTC114ES	
D311	8-719-304-37	DIODE SEL4414E-C		Q304	8-729-900-80	TRANSISTOR DTC114ES	
D312	8-719-302-46	DIODE SEL1210S-C-2		Q305	8-729-620-05	TRANSISTOR 2SC2603-EF	
D313	8-719-912-20	DIODE 1SS120		Q306	8-729-900-61	TRANSISTOR DTA114ES	
D314	8-719-912-20	DIODE 1SS120		Q307	8-729-119-76	TRANSISTOR 2SA1175-HFE	
D315	8-719-912-20	DIODE 1SS120		Q308	8-729-900-61	TRANSISTOR DTA114ES	
D316	8-719-912-20	DIODE 1SS120		Q309	8-729-900-80	TRANSISTOR DTC114ES	
D317	8-719-912-20	DIODE 1SS120		Q310	8-729-900-80	TRANSISTOR DTC114ES	
D318	8-719-912-20	DIODE 1SS120		Q311	8-729-119-76	TRANSISTOR 2SA1175-HFE	
D319	8-719-200-77	DIODE 10E2N		Q312	8-729-620-05	TRANSISTOR 2SC2603-EF	
D401	8-719-200-77	DIODE 10E2N		Q313	8-729-900-61	TRANSISTOR DTA114ES	
D402	8-719-200-77	DIODE 10E2N		Q314	8-729-900-80	TRANSISTOR DTC114ES	
D403	8-719-200-77	DIODE 10E2N		Q315	8-729-194-57	TRANSISTOR 2SC945-P	
D404	8-719-200-77	DIODE 10E2N		Q316	8-729-194-57	TRANSISTOR 2SC945-P	
D405	8-719-000-81	DIODE UZL-7L3		Q401	8-729-209-15	TRANSISTOR 2SD2012	
				Q402	8-729-111-67	TRANSISTOR 2SB1094-L	
				Q403	8-729-620-05	TRANSISTOR 2SC2603-EF	

AUDIO

PIN JACK

POWER SW

POWER SUPPLY

Ref. No.	Part No.	Description	Remark		
< RESISTOR >					
R101	1-249-431-11	CARBON	15K	5%	1/4W
R102	1-249-417-11	CARBON	1K	5%	1/4W
R103	1-249-423-11	CARBON	3.3K	5%	1/4W
R104	1-249-423-11	CARBON	3.3K	5%	1/4W
R105	1-247-864-11	CARBON	24K	5%	1/4W
R106	1-249-414-11	CARBON	560	5%	1/4W
R107	1-249-431-11	CARBON	15K	5%	1/4W
R108	1-249-425-11	CARBON	4.7K	5%	1/4W
R109	1-249-421-11	CARBON	2.2K	5%	1/4W
R110	1-249-417-11	CARBON	1K	5%	1/4W
R111	1-249-429-11	CARBON	10K	5%	1/4W
R113	1-249-423-11	CARBON	3.3K	5%	1/4W
R114	1-249-429-11	CARBON	10K	5%	1/4W
R115	1-247-838-00	CARBON	2K	5%	1/4W
R116	1-249-441-11	CARBON	100K	5%	1/4W
R117	1-249-431-11	CARBON	15K	5%	1/4W
R118	1-247-887-00	CARBON	220K	5%	1/4W
R119	1-249-430-11	CARBON	12K	5%	1/4W
R120	1-249-426-11	CARBON	5.6K	5%	1/4W
R121	1-247-882-11	CARBON	130K	5%	1/4W
R123	1-249-404-00	CARBON	82	5%	1/4W
R124	1-247-889-00	CARBON	270K	5%	1/4W
R125	1-249-430-11	CARBON	12K	5%	1/4W
R126	1-249-405-11	CARBON	100	5%	1/4W
R201	1-249-431-11	CARBON	15K	5%	1/4W
R202	1-249-417-11	CARBON	1K	5%	1/4W
R203	1-249-423-11	CARBON	3.3K	5%	1/4W
R204	1-249-423-11	CARBON	3.3K	5%	1/4W
R205	1-247-864-11	CARBON	24K	5%	1/4W
R206	1-249-414-11	CARBON	560	5%	1/4W
R207	1-249-431-11	CARBON	15K	5%	1/4W
R208	1-249-425-11	CARBON	4.7K	5%	1/4W
R209	1-249-421-11	CARBON	2.2K	5%	1/4W
R210	1-249-417-11	CARBON	1K	5%	1/4W
R211	1-249-429-11	CARBON	10K	5%	1/4W
R213	1-249-423-11	CARBON	3.3K	5%	1/4W
R214	1-249-429-11	CARBON	10K	5%	1/4W
R215	1-247-838-00	CARBON	2K	5%	1/4W
R216	1-249-441-11	CARBON	100K	5%	1/4W
R217	1-249-431-11	CARBON	15K	5%	1/4W
R218	1-247-887-00	CARBON	220K	5%	1/4W
R219	1-249-430-11	CARBON	12K	5%	1/4W
R220	1-249-426-11	CARBON	5.6K	5%	1/4W
R221	1-247-882-11	CARBON	130K	5%	1/4W
R223	1-249-404-00	CARBON	82	5%	1/4W

Ref. No.	Part No.	Description	Remark		
R224	1-247-889-00	CARBON	270K	5%	1/4W
R225	1-249-430-11	CARBON	12K	5%	1/4W
R226	1-249-405-11	CARBON	100	5%	1/4W
R301	1-249-437-11	CARBON	47K	5%	1/4W
R302	1-249-417-11	CARBON	1K	5%	1/4W
R303	1-249-429-11	CARBON	10K	5%	1/4W
R304	1-215-455-00	METAL	27K	1%	1/6W
R305	1-249-421-11	CARBON	2.2K	5%	1/4W
R306	1-249-421-11	CARBON	2.2K	5%	1/4W
R307	1-247-864-11	CARBON	24K	5%	1/4W
R308	1-249-429-11	CARBON	10K	5%	1/4W
R309	1-249-414-11	CARBON	560	5%	1/4W
R310	1-249-409-11	CARBON	220	5%	1/4W
R311	1-249-409-11	CARBON	220	5%	1/4W
R312	1-249-415-11	CARBON	680	5%	1/4W
R313	1-249-429-11	CARBON	10K	5%	1/4W
R314	1-249-421-11	CARBON	2.2K	5%	1/4W
R315	1-249-421-11	CARBON	2.2K	5%	1/4W
R316	1-249-429-11	CARBON	10K	5%	1/4W
R317	1-249-429-11	CARBON	10K	5%	1/4W
R318	1-249-429-11	CARBON	10K	5%	1/4W
R319	1-249-433-11	CARBON	22K	5%	1/4W
R320	1-249-429-11	CARBON	10K	5%	1/4W
R321	1-249-437-11	CARBON	47K	5%	1/4W
R322	1-249-420-11	CARBON	1.8K	5%	1/4W
R323	1-249-421-11	CARBON	2.2K	5%	1/4W
R324	1-249-433-11	CARBON	22K	5%	1/4W
R325	1-249-417-11	CARBON	1K	5%	1/4W
R326	1-249-434-11	CARBON	27K	5%	1/4W
R327	1-249-430-11	CARBON	12K	5%	1/4W
R328	1-249-423-11	CARBON	3.3K	5%	1/4W
R329	1-247-838-00	CARBON	2K	5%	1/4W
R330	1-247-852-11	CARBON	7.5K	5%	1/4W
R331	1-249-415-11	CARBON	680	5%	1/4W
R332	1-249-415-11	CARBON	680	5%	1/4W
R333	1-249-432-11	CARBON	18K	5%	1/4W
R334	1-249-432-11	CARBON	18K	5%	1/4W
R335	1-249-387-11	CARBON	3.3	5%	1/4W
R336	1-249-387-11	CARBON	3.3	5%	1/4W
R337	1-249-409-11	CARBON	220	5%	1/4W
R338	1-249-423-11	CARBON	3.3K	5%	1/4W
R401	1-249-411-11	CARBON	330	5%	1/4W
R402	1-249-411-11	CARBON	330	5%	1/4W
R403	1-249-411-11	CARBON	330	5%	1/4W
R404	1-249-411-11	CARBON	330	5%	1/4W
R405	1-249-419-11	CARBON	1.5K	5%	1/4W
R406	1-249-418-11	CARBON	1.2K	5%	1/4W
R501	1-249-438-11	CARBON	56K	5%	1/4W
R502	1-249-436-11	CARBON	39K	5%	1/4W

AUDIO

PIN JACK

POWER SW

POWER SUPPLY

SWITCH

Ref. No.	Part No.	Description	Remark
R503	1-249-437-11	CARBON	47K 5% 1/4W
R504	1-249-440-11	CARBON	82K 5% 1/4W
R505	1-247-881-00	CARBON	120K 5% 1/4W
R506	1-249-438-11	CARBON	56K 5% 1/4W
R507	1-249-440-11	CARBON	82K 5% 1/4W
R508	1-247-872-11	CARBON	51K 5% 1/4W
R509	1-247-883-00	CARBON	150K 5% 1/4W
R510	1-247-880-11	CARBON	110K 5% 1/4W
R511	1-249-440-11	CARBON	82K 5% 1/4W
R512	1-247-885-00	CARBON	180K 5% 1/4W
R513	1-247-876-11	CARBON	75K 5% 1/4W
R514	1-249-438-11	CARBON	56K 5% 1/4W
R515	1-249-438-11	CARBON	56K 5% 1/4W
R516	1-249-438-11	CARBON	56K 5% 1/4W
R517	1-247-881-00	CARBON	120K 5% 1/4W
R518	1-247-887-00	CARBON	220K 5% 1/4W
< VARIABLE RESISTOR >			
RV101	1-228-994-00	RES. ADJ. METAL10K (REC LEVEL)	
RV102	1-228-994-00	RES. ADJ. METAL10K (PB LEVEL)	
RV201	1-228-994-00	RES. ADJ. METAL10K (REC LEVEL)	
RV202	1-228-994-00	RES. ADJ. METAL10K (PB LEVEL)	
RV301	1-241-495-11	RES. VAR. CARBON 20K/20K (REC LEVEL)	
RV302	1-241-494-11	RES. VAR. CARBON 5K/5K (BALANCE)	
RV303	1-241-498-11	RES. VAR. CARBON 5K (BIAS)	
< RELAY >			
RY301	1-515-726-11	RELAY	
< SWITCH >			
S301	1-571-292-11	SWITCH, PUSH (1 KEY) (DOLBY NR)	
S302	1-571-292-11	SWITCH, PUSH (1 KEY) (DOLBY NR)	
S401	1-570-393-21	SWITCH, PUSH (1 KEY) (POWER)	
< TRANSFORMER >			
T301	1-433-365-11	TRANSFORMER, BIAS OSCILLATION	

*	1-635-160-11	SWITCH, BOARD	*****
< CONNECTOR >			
CN303	1-564-500-11	PIN, CONNECTOR 7P	

Ref. No.	Part No.	Description	Remark
< SWITCH >			
S501	1-571-736-11	SWITCH, LEAF	
S502	1-572-335-11	SWITCH, LEAF	
S503	1-571-736-11	SWITCH, LEAF	
S504	1-572-335-11	SWITCH, LEAF	

MISCELLANEOUS			

14	△	1-551-188-XX	CORD, POWER (E) (MADE IN MALAYSIA)
14	△	1-551-506-XX	CORD, POWER (US, Canadian) (MADE IN JAPAN)
14	△	1-551-628-12	CORD, POWER (US, Canadian) (MADE IN MALAYSIA)
14	△	1-551-884-32	CORD, POWER (UK) (MADE IN MALAYSIA)
14	△	1-551-908-11	CORD, POWER (AEP) (MADE IN MALAYSIA)
16	△	1-569-007-11	ADAPTOR CONNECTION 2P (E)
26		1-548-596-61	COUNTER, TAPE (MIDDLE TYPE)
HE		1-543-673-11	HEAD, MAGNETIC (ERASE)
HRP		1-543-319-11	HEAD, MAGNETIC (REC/PB)
M501		X-3358-211-1	MOTOR (A) ASSY
S505	△	1-552-535-00	SWITCH, POWER & VOLTAGE CHANGE (E)
T401	△	1-449-388-11	TRANSFORMER, POWER (E)
T401	△	1-449-593-11	TRANSFORMER, POWER (US, Canadian)
T401	△	1-450-442-21	TRANSFORMER, POWER (AEP, UK)

ACCESSORY & PACKING MATERIAL			

		1-559-533-11	CORD, CONNECTION
*		3-349-037-01	CUSHION (MADE IN JAPAN)
*		3-364-606-01	CUSHION (MADE IN MALAYSIA)
*		3-354-979-21	INDIVIDUAL CARTON (MADE IN JAPAN)
*		3-364-604-11	INDIVIDUAL CARTON (MADE IN MALAYSIA)
		3-703-450-01	INSTRUCTION (US)
		3-752-875-11	MANUAL, INSTRUCTION (ENGLISH, F. D. RC) (AEP, Canadian, E) (MADE IN MALAYSIA)
		3-752-875-21	MANUAL, INSTRUCTION (ENGLISH) (US, UK) (MADE IN JAPAN)
		3-752-875-41	MANUAL, INSTRUCTION (D. NL, S. I) (AEP) (MADE IN MALAYSIA)
		3-752-875-61	MANUAL, INSTRUCTION (ENGLISH) (US, UK) (MADE IN MALAYSIA)

Note:
The components identified by mark △ or dotted line with mark △ are critical for safety. Replace only with part number specified.

Note:
Les composants identifiés par une marque △ sont critiques pour la sécurité. Ne les remplacer que par une pièce portant le numéro spécifié.

Ref. No.	Part No.	Description	Remark
----------	----------	-------------	--------

HARDWARE LIST

# 1	7-682-547-04	SCREW +BVTT 3X6 (S)	
# 2	7-685-133-19	SCREW +P 2.6X6 TYPE2	
# 3	7-685-534-19	SCREW +BTP 2.6X8 TYPE2 N-S (E)	
# 4	7-685-645-79	SCREW +BVTP 3X6 TYPE2 N-S	
# 5	7-621-849-00	SCREW (BV/RING)	
# 6	7-685-646-79	SCREW +BVTP 3X8 TYPE2 N-S	
# 7	7-621-775-20	SCREW +B 2.6X5	
# 8	7-685-103-19	SCREW +P 2X5 TYPE2 NON-SLIT	
# 9	7-623-921-01	RING, RETAINING, CAPSTAN	
#11	7-623-505-01	LUG, 2	