

For U. S. A.

TC-800



Specifications

Power requirement :	DC 12 AC 117V 60 c/s
Track :	Dual
Reel :	13 cm (5") or smaller
Tape speed :	19 cm/s (7-1/2 ips), 9.5 cm/s (3-3/4 ips), 4.75 cm/s (1-7/8 ips)
Recording time :	1.5 hours in total at 9.5 cm/s (3-3/4 ips)
(with 900' (275 m) tape)	3 hours in total at 4.75 cm/s (1-7/8 ips)
Transistor :	14
Diode :	11
Frequency response :	50~18,000 c/s at 19 cm (7-1/2 ips) 50~13,000 c/s at 9.5 cm/s (3-3/4 ips) 50~7,000 c/s at 4.75 cm/s (1-7/8 ips)
Bias frequency :	Approx. 55 kc
Motor :	D-503F DC Motor
Speaker :	8×16 cm (3-1/8×6-1/4") dynamic
Power output :	Max. 1 watt
Input Jack :	Microphone (1) Sensitivity 0.195 mV Impedance 600 ohms Auxiliary (1) Sensitivity 0.055 V Impedance 100k ohms
Output Jack :	Monitor (1) Sensitivity 0.775 V Impedance 10k ohms
Other Jack :	Remote control (1) Speed control (1)
Power consumption :	AC 6W
Battery life :	6.5 hours recording with supplied batteries
Dimension :	322 (W)×107 (H)×261 mm (D) (12-1/4×4-1/5×10-1/4")
Weight :	5.4 kg (11 lbs. 13 ozs.) with battery
Accessories :	SONY Cardioid microphone F-85, "D" size super batteries, 5" empty reel, Power supply cord, Connection cord, Earphone
Optional accessories :	Speed slow-down control RM-5, Car battery cord DCC-2AW, Carrying case

SONY®

SERVICING GUIDE

Block Diagram

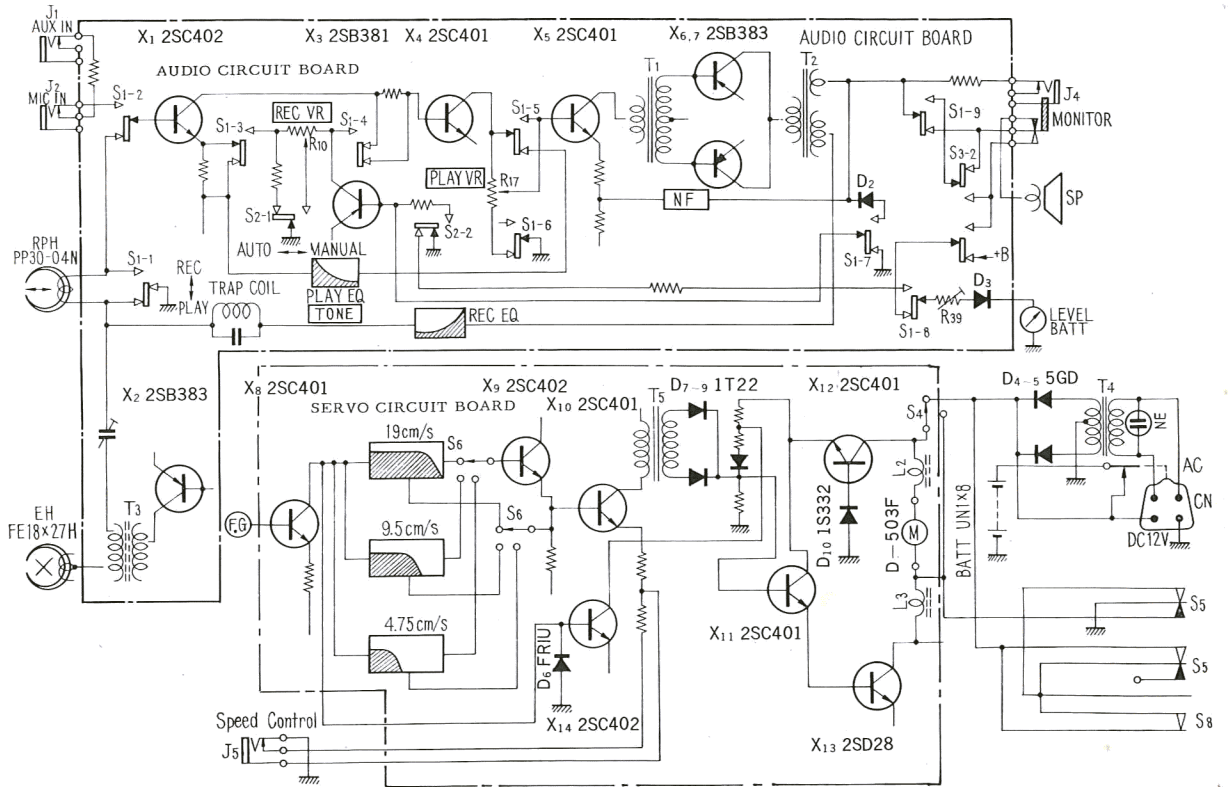

Cabinet Top View

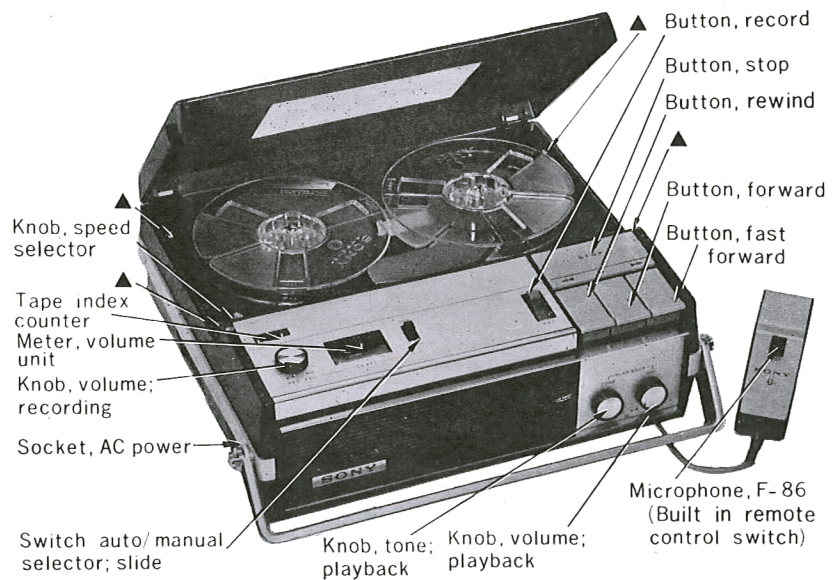

Chassis Top View

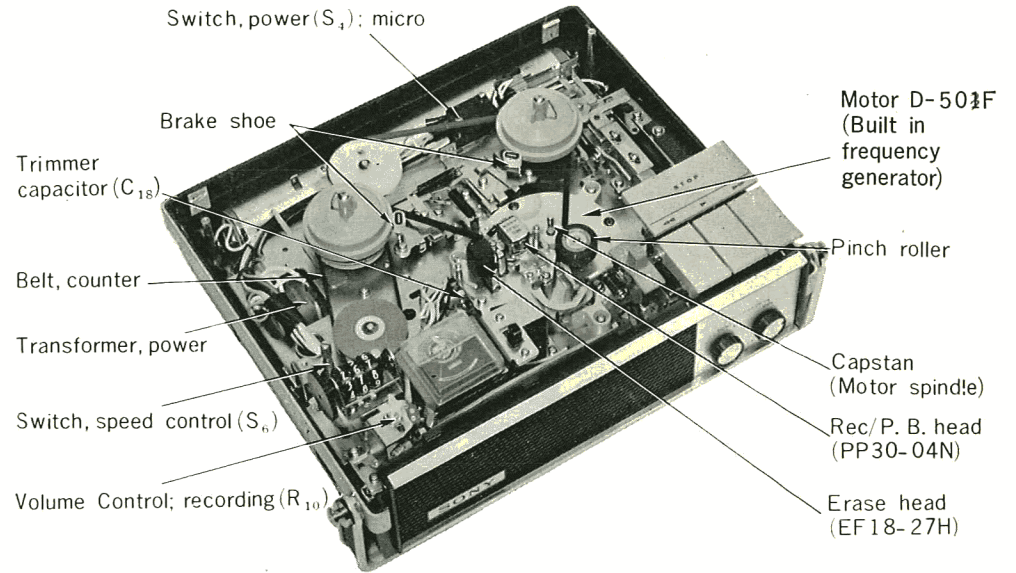

(Fig. 2)

Chassis Bottom View

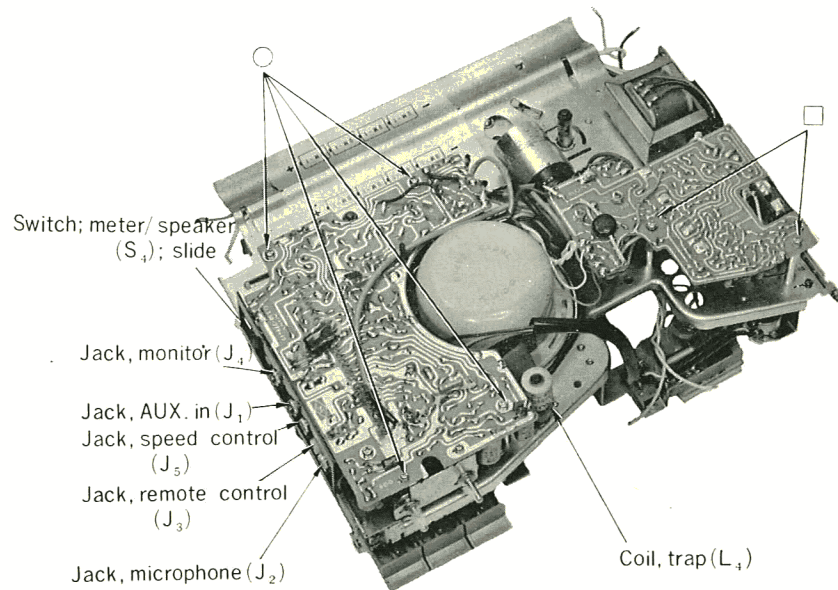

(Fig. 3)

Removal of Reel Panel

- (1) Pull out the Speed Selector Knob and the Recording Volume Control Knob.
 - (2) Unscrew the Head Cover for removal.
 - (3) Remove the four Screws marked with ▲ in Fig. 1.
 - (4) Pull the Panel forward and lift it gently for removal.
- Now, almost all of the mechanical section can be checked.

Removal of Cabinet

Remove the Panel according to the Removal of Panel.

- (1) Unsolder the four leads from the Battery Positive and Negative Contact Plates.
- (2) Unsolder two leads from the Terminal Board (1L1) to the Speaker.
- (3) Unscrew the Handle.
- (4) Pull out the Playback Tone Control Knob and the Playback Volume Control Knob.
- (5) Remove the five Screws marked with △ in Fig. 4.
- (6) Loosen the two Screws shown in Fig. 5 and push the AC Socket Attaching Plate inside in the direction shown by the arrow in Fig. 5.
- (7) Place the unit upside down and remove the Cabinet by opening with hands in the direction shown by the arrow in Fig. 7.

Note 1. Before the removal of the Cabinet, hold the VU meter with a rubber band or the like tentatively to prevent it from scratching.

Note 2. As the Motor surface is magnetized, take care that it is easy to attract magnetic materials such as a screw.

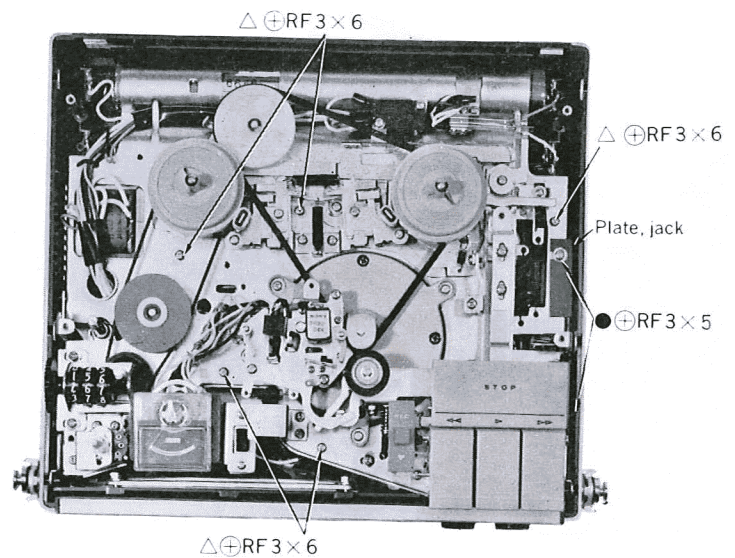

(Fig. 4)

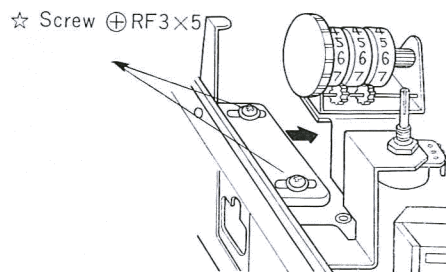

(Fig. 5)

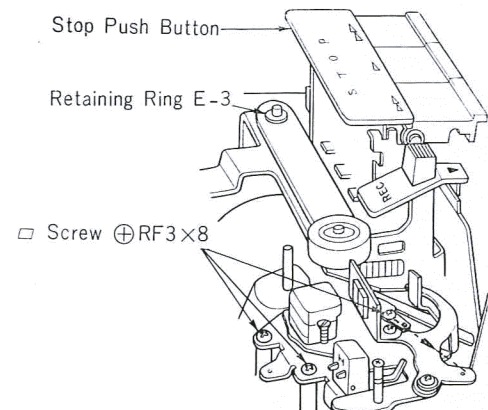

(Fig. 6)

Removal of Printed Circuit Boards

Audio Circuit Board :

- (1) Remove the four Screws marked with ○ in Fig. 3.
- (2) Remove the Nuts and the Washers holding the Mic. Jack, AUX Jack and the Monitor Jack in places.
- (3) Loosen the two Screws marked with ● shown in Fig. 4 and remove the Jack Holding Plate.

Now, the Audio Circuit Board can be turned over towards the Motor.

Note : Because B+ is applied to the Remote Jack at playback and recording modes, take care not to touch it with the Mic. Jack. If it touched, Fuse will blow.

Servo Circuit Board :

- (1) Remove the two Screws marked with □ shown in Fig. 3.
- (2) Remove the two Screws holding the Speed Selector Switch near the Power Transformer.

Now, the Servo Circuit Board can be turned over toward the Motor.

Note : When attaching the Servo Circuit Board, apply the Fiber Washer to the Holding Screw near the Motor to prevent it from contacting with the copper foil of the circuit board.

Removal of Motor

- (1) Unsolder the four leads coming from the Motor.
- (2) Remove the three Screws shown by the arrows in Fig. 6 and remove the Head Deck.
- (3) Remove the four Screws holding the Push Button block and remove it.
- (4) Remove the Retaining Ring and remove the Pinch Roller Mounting Bracket.
- (5) Remove the three Screws holding the Motor and remove the Motor.
- (6) Remove the three Studs attached to the Motor, and attach them to the new Motor.
- (7) When attaching the Head Deck and the Lug with the Screw, set the direction of the Lug as shown by the arrow in Fig. 6 so that the Lug does not catch the Head Shielding Plate.

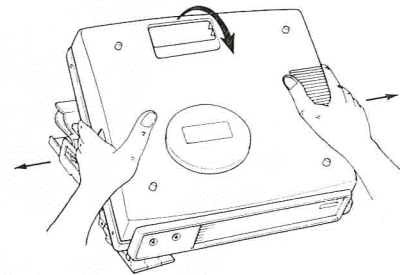

(Fig. 7)

Pinch lever Adjustment

For adjusting the play of the FWD Knob and the pressure of the Pinch Roller, proceed as follows. See Fig. 8.

- (1) Set the recorder to "STOP", Loosen the two adjusting Screws ① on the Forward Control Lever so that the roller of the Pinch Lever Adjusting Plate contacts at the two points on the F.F Lever. (A in Fig. 8)
- (2) After the adjustment (1), fix the Adjusting Screws ① firmly. (For adjusting the play of the FWD Knob).
- (3) Adjust the Adjusting Screws ② so that the clearance between the Capstan (Motor Shaft) and the Pinch Roller is approximately 7 mm. As the Adjusting Screw is loosened, the clearance becomes narrower.
- (4) After the adjustment (3), fix the Nut for the Adjusting Screw ②.
- (5) Hook the tension gauge on the Pinch Roller at forward mode.
- (6) Pull the tension gauge forwards and adjusting Screw ③ so that the tension gauge reads 600~700 grs. when the Pinch Roller leaves the Capstan (Motor Shaft). (The pressure of the Pinch Roller increases as the Adjusting Screw ③ is tightened.)

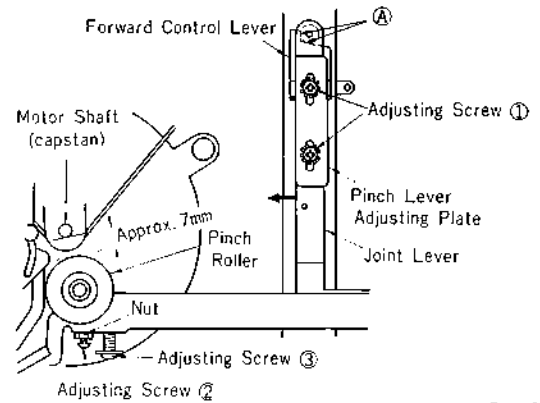

(Fig. 8)

Torque Adjustment of Take-up Reel Table

When replacing the Take-up Reel Table, proceed torque adjustment as follows.

- (1) Loosen the Screw ① shown in Fig. 9 enough in a horizontal position.
- (2) Loosen the Torque Adjusting Screw ② enough.
- (3) Put 3" Reels with a tape on the Reel Tables and set it at start position.
- (4) Turn the Torque Adjusting Screw ② until the tape is rewound completely at forward mode. (torque 40 to 60 g-cm)
- (5) Make sure that the tape is also rewound completely at the vertical playing position.
- (6) Take care that too much tightening of the Torque Adjusting Screw causes the increase in power consumption.
- (7) After adjustment, tighten the Screw ①.

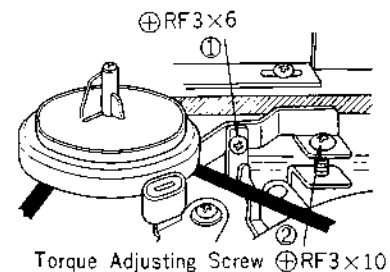

(Fig. 9)

Friction Felt

Molybdenum disulphide "MOLYCOAT" is applied over the Friction Felt surface for smoothing it and correcting uneven torque.

When replacing the Friction Felt, never fail to apply molybdenum disulphide "MOLYCOAT" over the Felt surface for smoothing it.

Brake Alignment

When the tape slacks at stop mode, adjust the Brake as follows. Refer to Fig. 10.

Loosen the Adjusting Screw and adjust the Brake Arms, both right and left, so that the center of the Brake Shoe contacts with the Reel Table at stop mode.

Level Meter Calibration (Battery)

- (1) Connect the Battery (DC9V) to the Battery leads (red and black).
- (2) Lay the Meter Selecting Switch (S_3) down to the Battery side.
- (3) Place the tape recorder in play mode.
- (4) Adjust the Adjustable Resistor (R_{11} , 200K Ω) on the Audio Circuit Board so that the pointer of the Level Meter is just at the boundary between the Red portion and the Black portion.

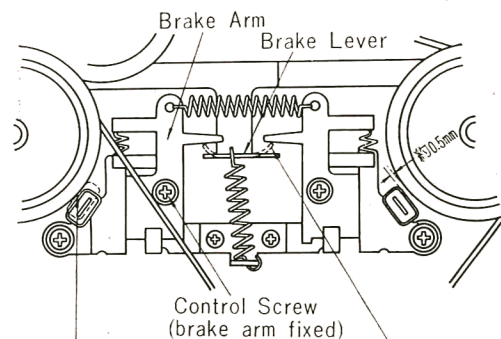

Set Brake Shoe so that its center part presses against Feed Reel at stop mode.

For the Sets up to Serial Number 16,600

(Fig. 10-1)

Recording Meter Calibration

- (1) Feed a 1000 c/s signal of -10 dBs (approx. 0.25V) to the AUX input Jack.
- (2) Set the Auto/Manual Selector Switch to Manual.
- (3) Set the Speed Selector Switch (S_3) to OFF.
- (4) Connect the VTVM across, R_{29} (8 Ω).
- (5) Place the tape recorder in record mode.
- (6) Set the REC Volume Control Knob (R_{10} , 10K Ω) so that the VTVM indicates 0 dBs (approx. 0.78V).
- (7) Adjust the Adjustable Resistor (R_{39} , 3K Ω) on the Audio Circuit Board so that the Level Meter indicates 0.

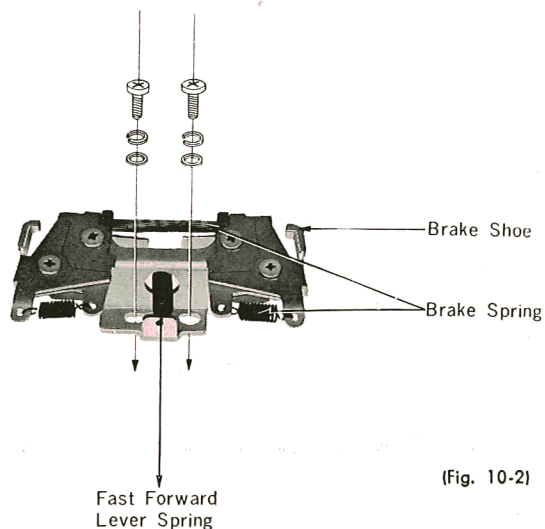

(Fig. 10-2)

For the Sets with Serial Number after 16,601

Lubrication

Lubricate the Reel Table Spindles, the Pinch Roller and the REW Pulley with a bit of SONY Oil OL-1K per approximately 300 employed hours. It is unnecessary to lubricate the Motor Shaft (Capstan).

Note: When lubricating each Reel Table Spindle, remove the Retaining Ring and the Nylon Washers at the bottom of the Reel Table Spindle and pull out the Spindle; lubricate the Take-up Reel Spindle in REW mode and the Supply Reel Spindle in F.F mode.

Speed Adjustment

Check the tape speed with the timing tape.

When getting no standard speed, remove the Panel and adjust the Adjustable Resistor according to the Table 1, with the insulated screw Driver without fail. See Fig. 11.

Adjustment tape speed	Adjusting Place	Adjusting Method	
		When slower than standard	When faster than standard
4.75 cm/sec.	Adjustable Resistor (R ₆₄ 5 K Ω)	counter-clockwise	clockwise
9.5 cm/sec.	Adjustable Resistor (R ₅₈ 5 K Ω)	counter-clockwise	clockwise
19 cm/sec.	Adjustable Resistor (R ₅₂ 5 K Ω)	counter-clockwise	clockwise

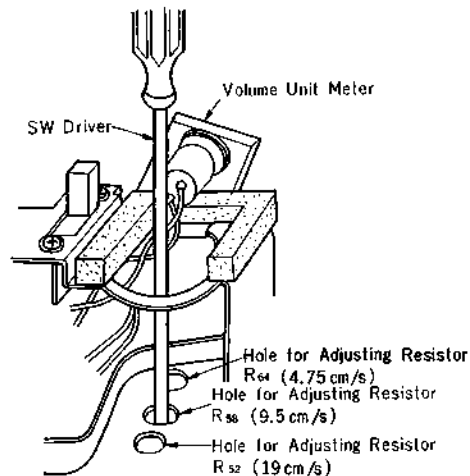

(Fig. 11)

Recording Bias Adjustment

After repairing the Oscillation Circuit or replacing the REC/P.B. Head, never fail to adjust the recording bias as follows. See Fig. 12.

- (1) Remove the lead (ground side at record mode) from the Recording head and connect a 1K Ω resistor in series.
- (2) Set the Auto/Manual Selector Switch to Manual and place the tape recorder in record mode.
- (3) With the Range Selector Knob set to AC, connect the VTVM across the resistor. (probe to the Head side)
- (4) Adjust the Trimmer Capacitor (C₁₉) so that the VTVM indicates approximately 2V.

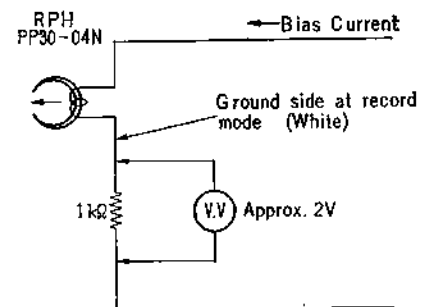

(Fig. 12)

Trap Coil Adjustment

The Trap Coil is used so that bias frequency signal does not come into the AMP section. After repairing the Oscillation Circuit or replacing the Trap Coil (Fig. 14), adjust the trap coil as follows.

- (1) Set Recording Volume Control to minimum.
- (2) Set the Auto/Manual Selector Switch to Manual and place the recorder in record mode.
- (3) Connect the VTVM between the terminal on the red lead of the Trap Coil, and the Ground.
- (4) Turn the core of the Trap Coil clockwise to the full.
- (5) Adjust the core by turning it counter-clockwise so that the VTVM indicates minimum.

Note for Repair

- (1) The Lug for ground on the printed side of the Audio Circuit Board should not contact with the B+ pattern as shown in Fig. 13.
- (2) The Neon Lamp is attached under the Level Meter for indicating AC operation. The leads of the Neon Lamp should be kept off the leads of the Recording Volume Control and the Auto/Manual Selector Switch as much as possible to avoid hum at record mode.
- (3) The Micro Inductor L_1 on the Audio Circuit Board should be bent toward the Jack side to avoid magnetic coupling with the Trap Coil L_4 . In case of the coupling the Pointer of the Meter moves ever at no signal.

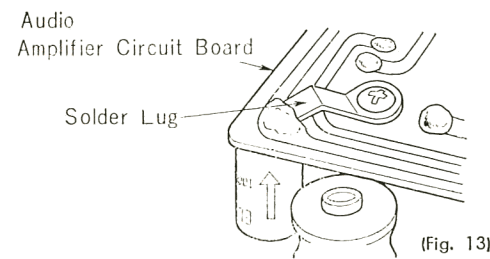

(Fig. 13)

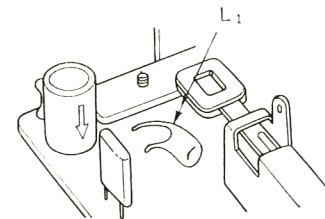

(Fig. 14)

Lead Indication and Color Code of Silicon Transistor 2SC40(A)-(B)

- The leads of the Transistor 2SC40(A)-(B) are attached in the order of Emitter, Collector and Base from the left with the marked side of the transistor faced up as shown in Fig. 15.
- Color Code 2SC40(A)-(B)
Color means the specified digit to be pu. in (A) and (B) as follows.

digit	1	2	3	4	5	6
Position of color mark						
A (left or upper side)	red	yellow	white			
B (right or lower side)	brown	red	orange	yellow	green	blue

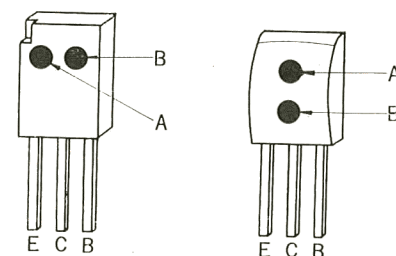

E...Emitter
C...Collector
B...Base

(Fig. 15)

Playback Level Diagram

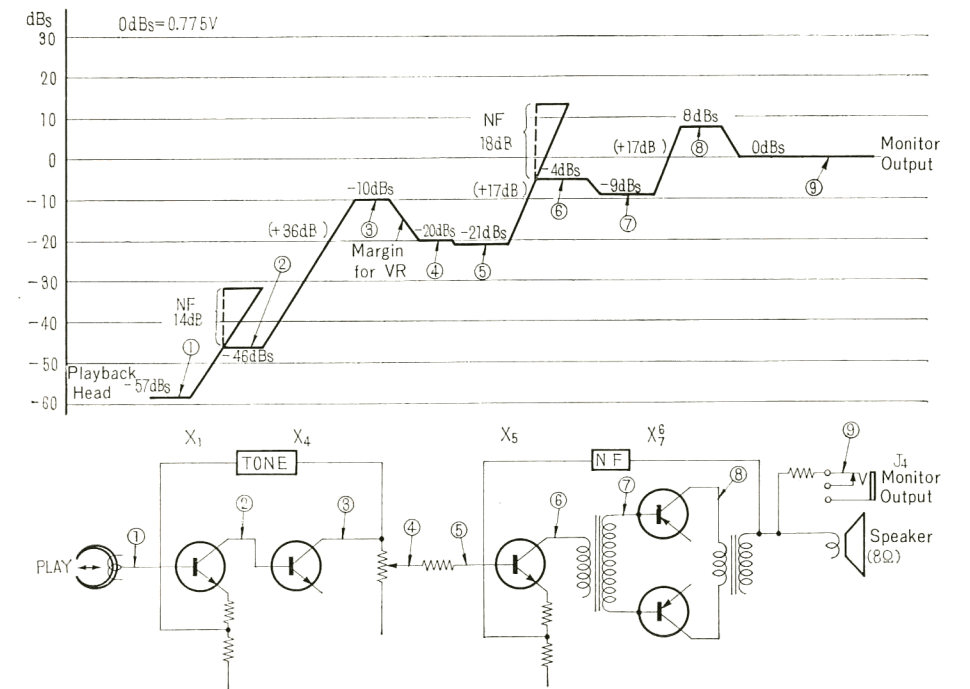

Recording Level Diagram

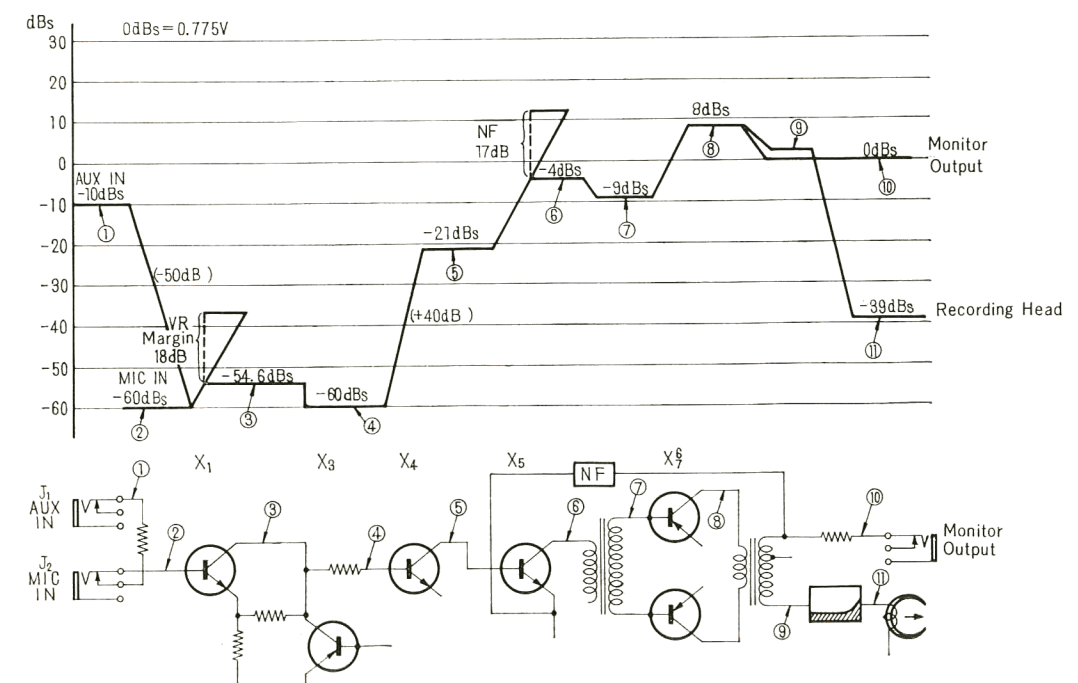

Circuit Schematic

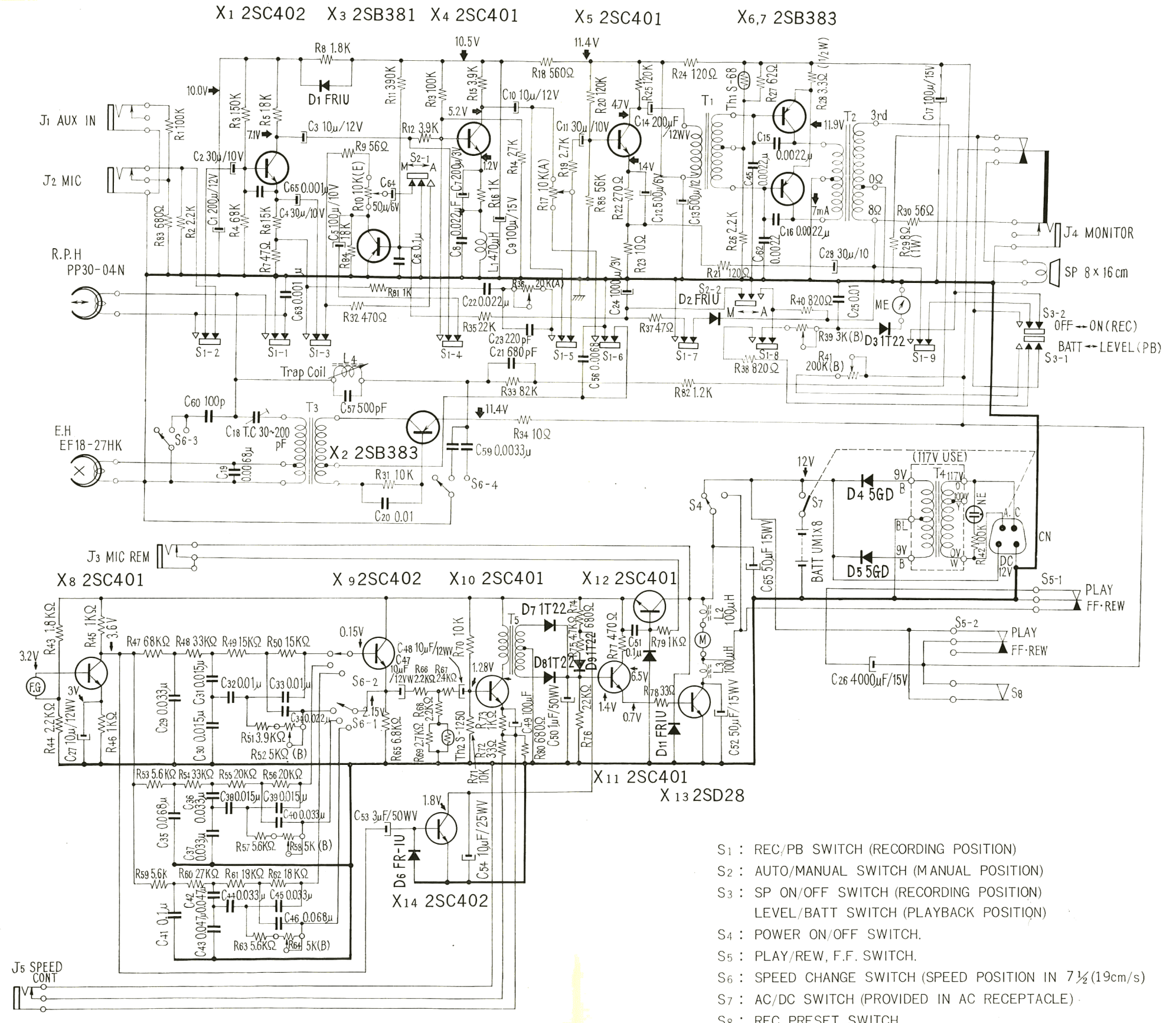

- S1 : REC/PB SWITCH (RECORDING POSITION)
- S2 : AUTO/MANUAL SWITCH (MANUAL POSITION)
- S3 : SP ON/OFF SWITCH (RECORDING POSITION)
LEVEL/BATT SWITCH (PLAYBACK POSITION)
- S4 : POWER ON/OFF SWITCH.
- S5 : PLAY/REW, F.F. SWITCH.
- S6 : SPEED CHANGE SWITCH (SPEED POSITION IN 7 1/2 (19cm/s)
- S7 : AC/DC SWITCH (PROVIDED IN AC RECEPTACLE)
- S8 : REC PRESET SWITCH.

Mounting Diagram

Servo Amplifier Section
—Printed Side—

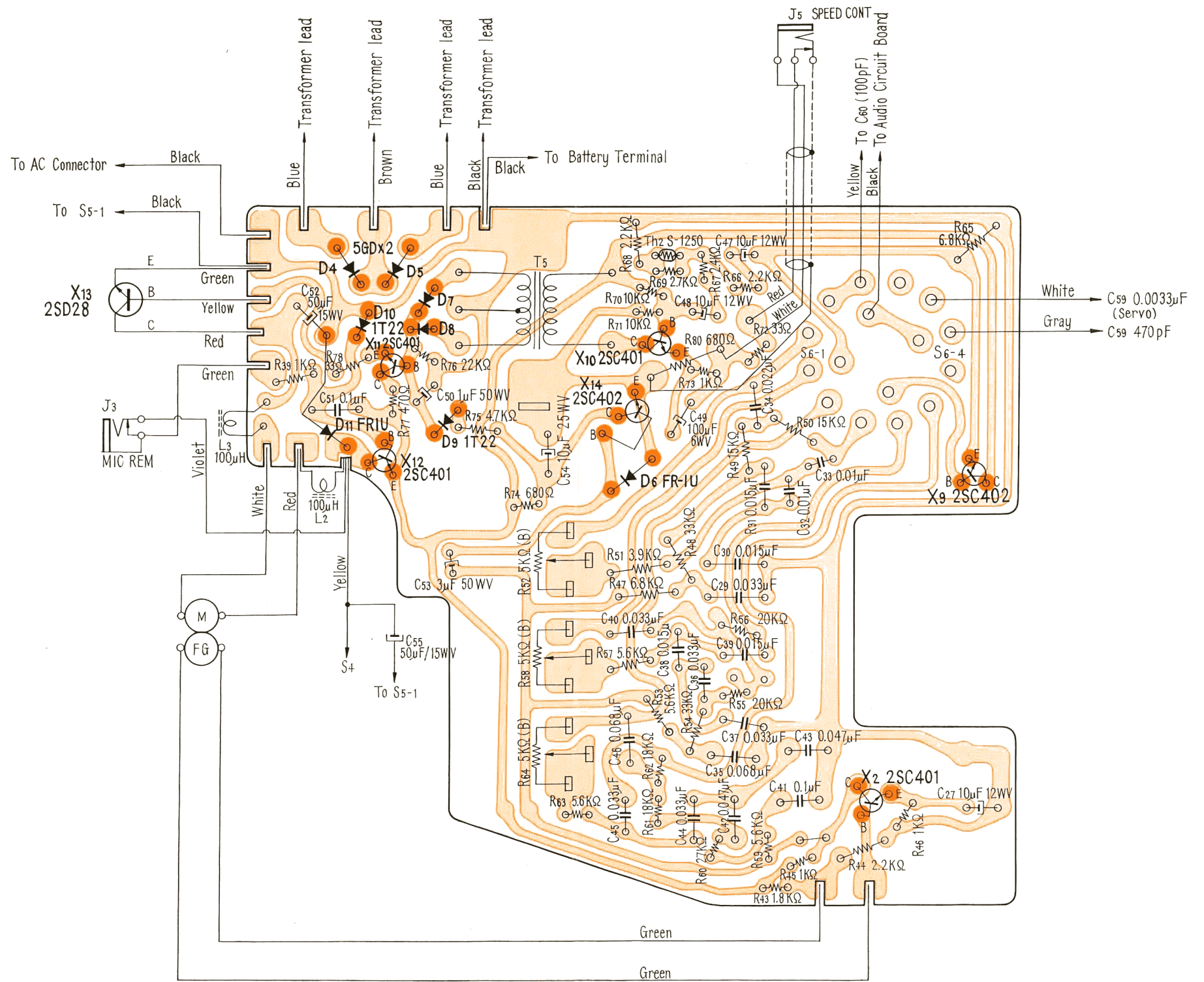

R49, R55 & R61 are adjustable Resistor

Mounting Diagram

Audio Amplifier Section
—Printed Side—

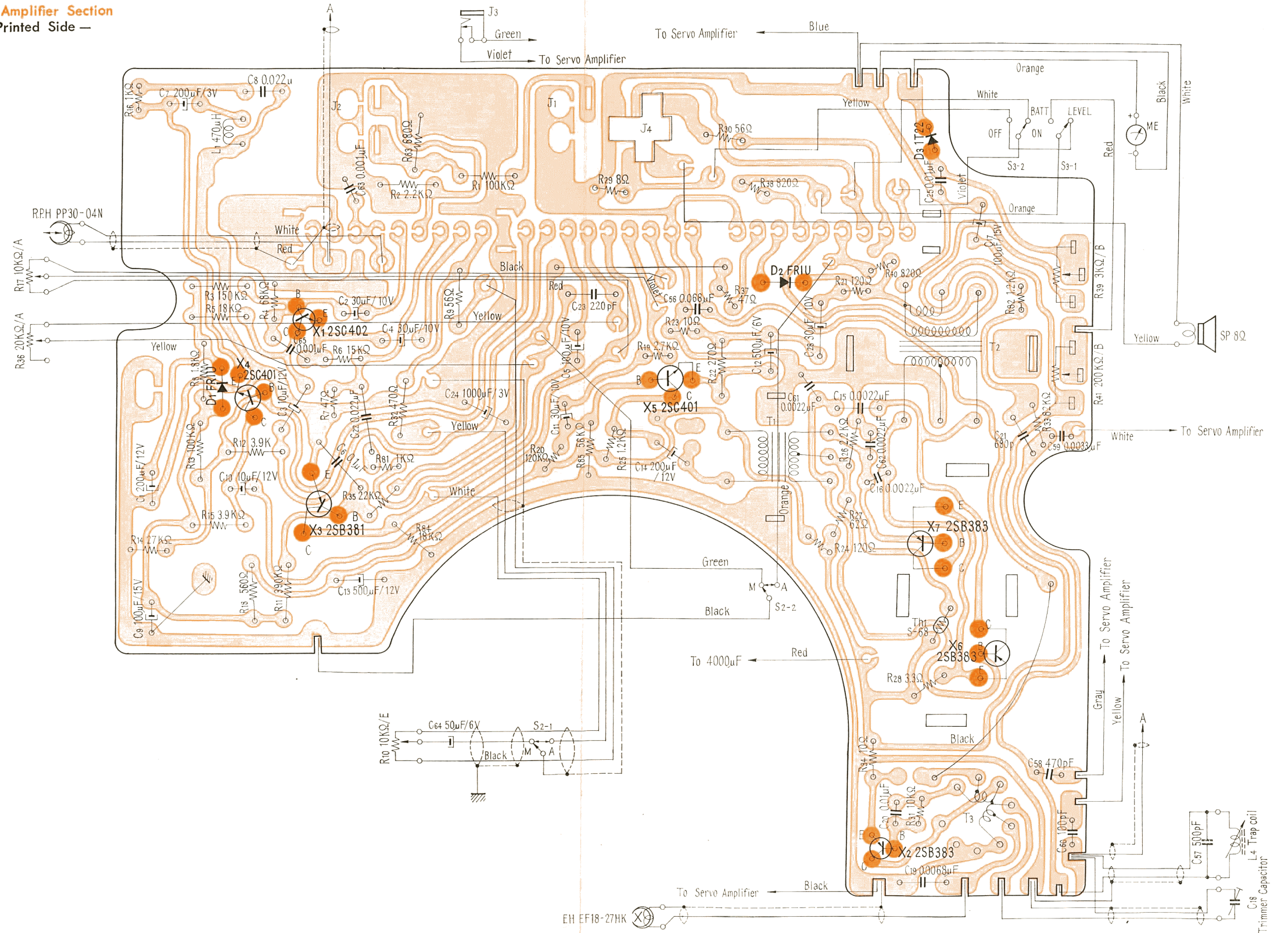

Parts List

I. Cabinet & Appearance Items

Ref. No.	Part No.	Description	Q'ty	Ref. No.	Ref. No.	Description	Q'ty
A9	X-34252-01-1	REEL PANEL ASSEMBLY	1	A19	X-34250-20-3	BATTERY COMPARTMENT LID ASSEMBLY	1
A15	X-34250-17-3	HANDLE GRIP ASSEMBLY	1	A17-4	X-34250-30-1	SPEAKER GRILLE ASSEMBLY	1
A16	X-34250-18-2	CABINET COVER ASSEMBLY	1				
A17	X-34250-19-2	CABINET BODY ASSEMBLY	1				

II. Mechanical Parts

Ref. No.	Part No.	Description	Q'ty	Ref. No.	Part No.	Description	Q'ty
A1	X-34250-01-	BASE PLATE ASSEMBLY ; chassis	1	30	3-425-116-	PLATE, rec./p.b. head pad ; shield	1
A3	-02-	PINCH LEVER (A) ASSEMBLY	1		-119-	CLAMPER, electrolytic capacitor 4000µF 15WV	1
	-03-	" CONTROL PLATE ASSEMBLY	1		-120-	SPRING, stop button plate & recording lever	2
A4	-04-	FRICITION DISC ASSEMBLY, take-up reel table	1		-122-	" pinch lever (A)	1
A5	-05-	FRICITION PULLEY ASSEMBLY, take-up reel table	1	34	-123-	" pinch lever (B)	1
A5-1	-06-	LEVEL METER BRACKET ASSEMBLY	1	35	-124-	" friction control lever	1
	-07-	RECORDING LEVER ASSEMBLY	1	36	-125-	" brake lever, & fast forward lever	2
A8	-09-	REWIND PULLEY LEVER ASSEMBLY	1	37	-127-	" rec./p.b. head pad lever	1
				38	-128-	" tape shifter	1
A10	X-34250-12-	SUPPLY REEL TABLE ASSEMBLY	1	39	-129-	" rewind lever	1
A11	X-34250-13-	TAKE-UP REEL TABLE ASSEMBLY	1	40	-130-	" lever meter bracket	1
A12	X-34250-14-	PUSH BUTTON ASSEMBLY, stop	1	41	-131-	" lock plate	1
A13	-15-	PUSH BUTTON ASSEMBLY, forward, fast forward & rewind	3	42	-132-	BUTTON, record ; red plastic	1
A14	-16-	BRACKET ASSEMBLY, function selector button	1	43	-133-	PLATE, input & output connector lock ; dark gray	1
				44	-134-01	KNOB, speed selector ; light gray	1
	X-34250-22-	BRAKE LEVER ASSEMBLY	1	45	-135-01	COVER, head	1
A25	X-34250-23-	BRAKE ASSEMBLY, supply reel table	1	46	-137-	SPACER, remote control lock	1
A24	-24-	BRAKE ASSEMBLY, take-up reel table	1	47	-138-	" mic input & remote control lock ; red	1
A20	X-34230-08-1	KNOB ASSEMBLY, volume, tone (playback) & volume (recording)	3	48	-139-	" forward lever ; milk white	2
				49	-140-	" fast forward lever ; milk white	6
	3-425-003-	SHAFT, pinch lever	1	50	-141-	PULLEY, rewind ; milk white	1
	-005-	LABEL, battery	1	51	-142-	BELT, tape counter ; rubber	1
	-033-	SPRING, friction disc : plate	3	52	-143-	PROTECTOR, input & output connector lock plate	1
	-072-	LEVER, forward	1	53	-144-	SPACER, speed selector knob ; black felt	1
1	-073-	" pinch (B)	1	54	-145-	LEVER, rewind	1
2	-074-	" friction control	1	55	-146-	" friction adjust	1
3	-079-	" function selector button	1	59	-148-	PLATE, auto/monaural selector switch shield	1
4	-080-	PLATE, stop button	1		-163-	SPACER, pinch roller	1
5	-081-	" lock	1		-165-	BRACKET, preset switch	1
6	-082-	BRACKET, power socket	1		-166-	PLATE, recording lever ; L shaped	1
7	-083-	" tape counter	1		-167-	CUSHION A, dark gray ; oblong	1
8	-084-	" speed selector switch	1		-168-	" B, dark gray ; L shaped	1
9	-085-	" volume & tone control (playback)	1		-169-	OIL RETAINER, take-up & supply reel table	2
10					-171-	WASHER, handle grip ; special	2
					-172-	SPRING, friction adjust	1
					-174-	SPACER, power ; fiber	1
13	-088-	PLATE, head deck	1		-175-	BELT, drive ; rubber	1
	-089-	LEVER, rec./p.b. head pad	1	65	-178-	PLATE, supply reel table brake	1
	-092-	" record lock (A), lower part	1	64	-179-	" take-up reel table brake	1
16	-093-	" record lock (B) ; upper part	1	65	-180-	MOUNTER, brake	1
				66	-183-	SPRING, brake plate	1
17	-094-	BRACKET, record volume control	1	67	-184-	" reel table brake	2
18	-097-	LEVER, fast forward	1	68	-185-	SCREW, brake ; special	4
19	-098-	SHAFT, function selector button	1		-186-	WASHER A, handle grip ; special lock	1
22	3-425-102-	SHIFTER, tape	1		-187-	WASHER B, handle grip ; special lock	1
23	-104-	SLEEVE, tape guide ; brass	2				
25	-105-	SUPPORTER, head deck plate	3				
	-108-	WASHER, ornamental, handle grip	2				
	-111-	SHIFTER, friction control lever	2				
28	-112-02	SPRING, rewind push button ; leaf	1				
28	-112-03	SPRING, fast forward push button ; leaf	1				
29	-114-	PLATE, tape guide	2				

Parts List

Ref. No.	Part No.	Description	Q'ty	Ref. No.	Part No.	Description	Q'ty	
	3-425-189-	BOSS, drive belt	1	99	3-005-001-70	SPRING, rec./p.b. head adjusting	1	
	-191-	COVER, oil retainer ; brass	2					
79	-192-	TAPE GUIDE	2		3-103-527-	STAPLE ; black, rubber	2	
	-195-	NUT, handle grip insulating	2		3-401-179-	LUG, 3φ (large)	1	
		WASHER, thrust ;			3-405-539-	" 3φ	1	
	-197-01	milke white 0.13 mm thick	8		3-408-016-	WASHER, forward lever	2	
	-197-11	milke white 0.25 mm thick	6		3-418-070-	SPRING, record lock lever (B)-large	1	
	-197-21	milke white 0.5 mm thick	10	90	-191-	SCREW, rec./p.b. head adjusting	1	
	-198-	LABEL, shield	1		-194-	Pinch Roller	1	
	-201-	" specification	1		-195-	OIL RETAINER, pinch roller	1	
	-802-05	" power socket	1		-196-	RING, pinch roller	1	
	-301-	BAG, polyethylene ; complete set	1		3-420-055-	PULLEY, tape counter ; brown	1	
					-076-	CUSHION, spring	1	
	-402-	BUSHING, handle grip	2		97	3-421-055-	WASHER, forward fast forward & rewind	5
	0-027-195-	SPRING, forward lever	1					
	-245-	WASHER, tape counter pulley & rewind pulley ; felt	2	98	3-423-101-	HEAT SINK, transistor 2SB383-2 X ₆₇	2	
					-102-	RETAINER, transistor 2SB383-2 X ₆₇ ; copper	2	
101	0-041-029-	WASHER, front panel ; nylon	4		8-701-030-	LABEL, serial no.	1	
	-129-	PAD, rec./p.b. head (small) & erase head	2		-026-	" volt indicating	1	
					Y-20165-61-1	TAPE COUNTER	1	
	0-051-340-	SPRING, record lock lever (B)-small-& rewind pulley lever	2		3-422-204-	CAUTION LABEL	1	
76	-363-	PAD, rec./p.b. head (large)	1					

III. Accessories & Miscellaneous

Ref. No.	Part No.	Description	Q'ty	Ref. No.	Part No.	Description	Q'ty
	3-790-220-21	MANUAL, instruction	1		1-504-034-12	EARPHONE ME-20	1
	3-701-020-	BAG, polyethylene ; accessory	1		1-506-009-01	CONNECTION CORD ; RK-36	1
	3-425-161-	CASE, vinyl ; accessory	1		3-793-030-	BOOKLET, SONY	1
	2-016-414-	BAG, polyethylene ; accessory case	1		3-796-111-11	INSPECTION CARD	1
					X-37010-08-1	HEAD CLEANING RIBBON	1
	3-793-010-	TAPE TALK	1		1-528-022-11	BATTERY, super UM-1	1
	8-811-850-10	MICROPHONE : F-85 (MTL)	1		1-534-284-	POWER CORD	1
	8-860-105-00	REEL R-5A	1		X-34250-25-3	CARTON ASSEMBLY	1
	8-852-034-12	TAPE S-5	1				

IV. Screws, Washers & Nut

Ref. No.	Part No.	Description	Q'ty	Ref. No.	Part No.	Description	Q'ty
	7-621-255-12	SCREW ⊕RF 2×3	4		7-622-110-02	NUT 4φ	1
	-255-32	" ⊕RF 2×5	2		7-623-105-02	WASHER 2φ (small)	2
	-256-02	" ⊕RF 2×16	2		-105-12	" 2φ	2
	-259-25	" ⊕RF 2.6×4	1		-107-02	" 2.6φ (small)	4
	-259-35	" ⊕RF 2.6×5	8		-107-12	" 2.6φ	3
	-259-42	" ⊕RF 2.6×6	1		-107-22	" 2.6φ (large)	2
	-261-35	" ⊕RF 3×5	4		-108-02	" 3φ (small)	8
	-261-45	" ⊕RF 3×6	38		-108-12	" 3φ	37
	-261-55	" ⊕RF 3×8	9		-110-02	" 4φ (small)	2
	-261-65	" ⊕RF 3×10	2		-112-17	" 5φ	1
	-261-75	" ⊕RF 3×12	3		-205-22	SPRING WASHER 3φ	8
	-261-85	" ⊕RF 3×14	2		-207-22	" 2.6φ	9
	-262-45	" ⊕RF 3×24	1		-208-22	" 3φ	61
	-659-67	" RK 2.6×10	2		-210-22	" 4φ	1
	-669-59	" ⊕RK 4×25	2		-408-04	STAR WASHER 3φ	2
	-559-45	" ⊕K 2.6×6	2		-508-01	LUG 3φ	2
	-770-99	" ⊕B 2.6×8	1		-510-01	" 4φ	1
	-461-49	" ⊕T 3×6	4		7-624-104-01	RETAINING RING E-2	1
	7-622-308-02	NUT 3φ (lock nut)	1		-106-01	" E-3	8
	-108-02	" 3φ	8				

Exploded Diagram

(1)

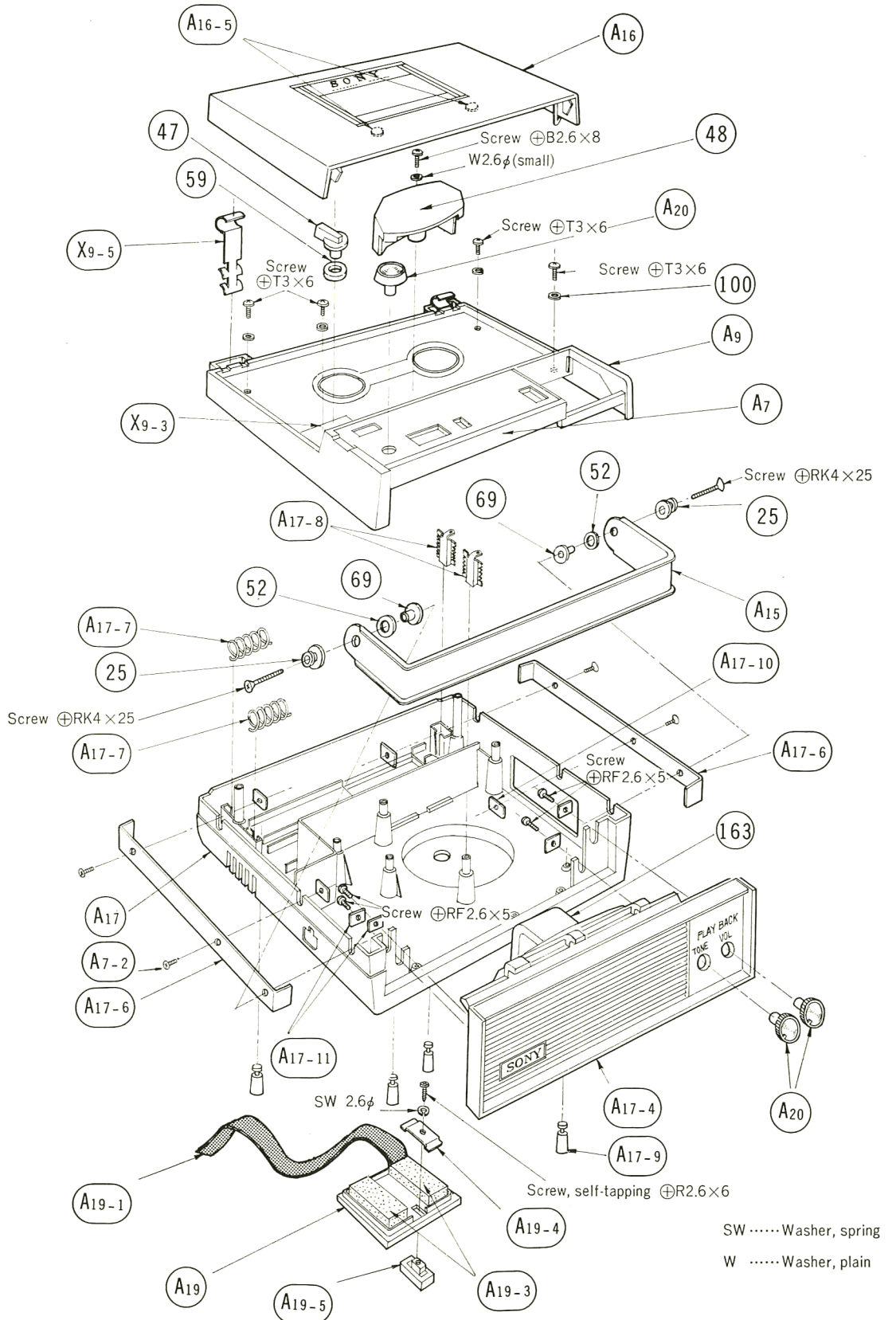

Exploded Diagram

(2)

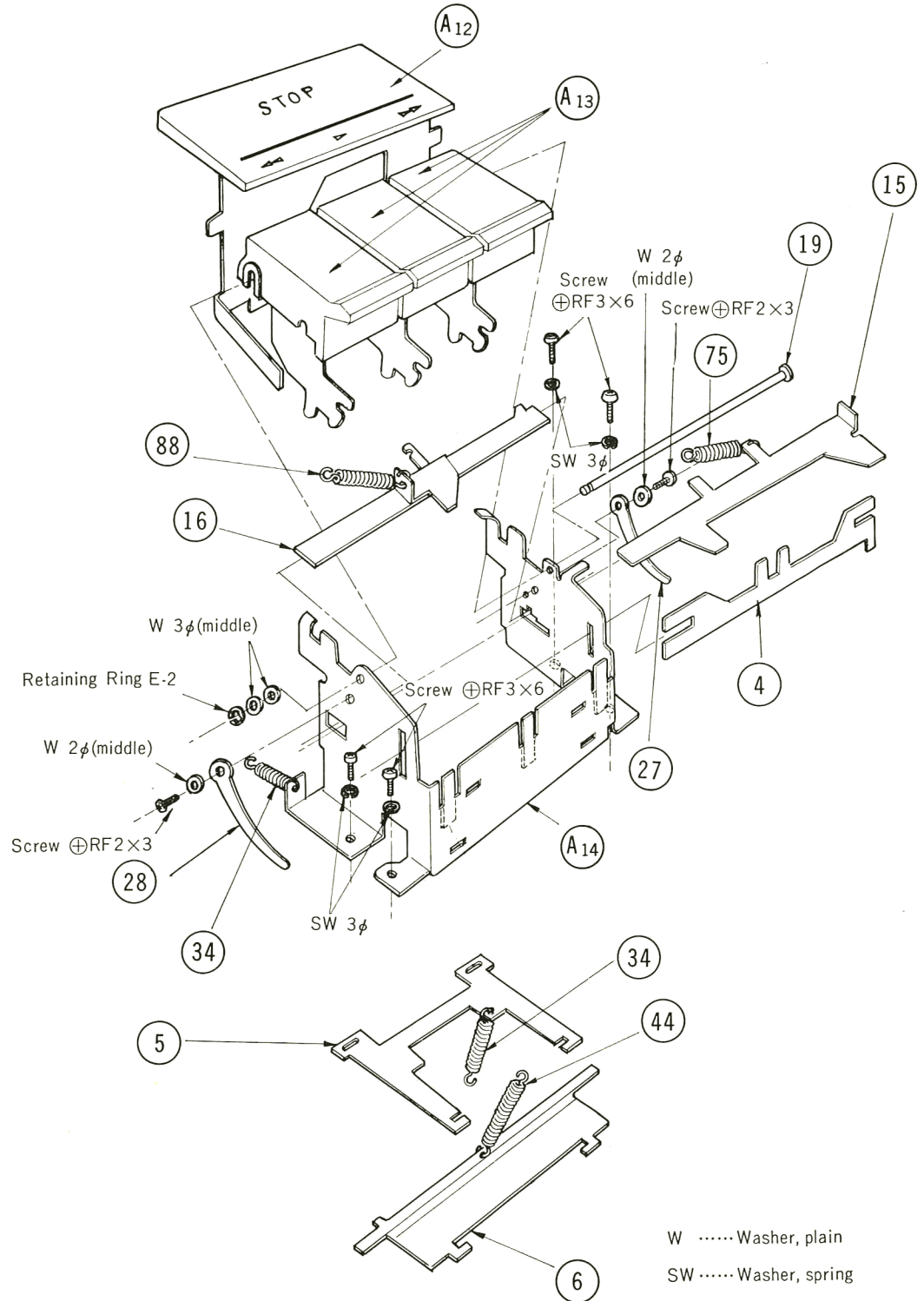

Exploded Diagram

(3)

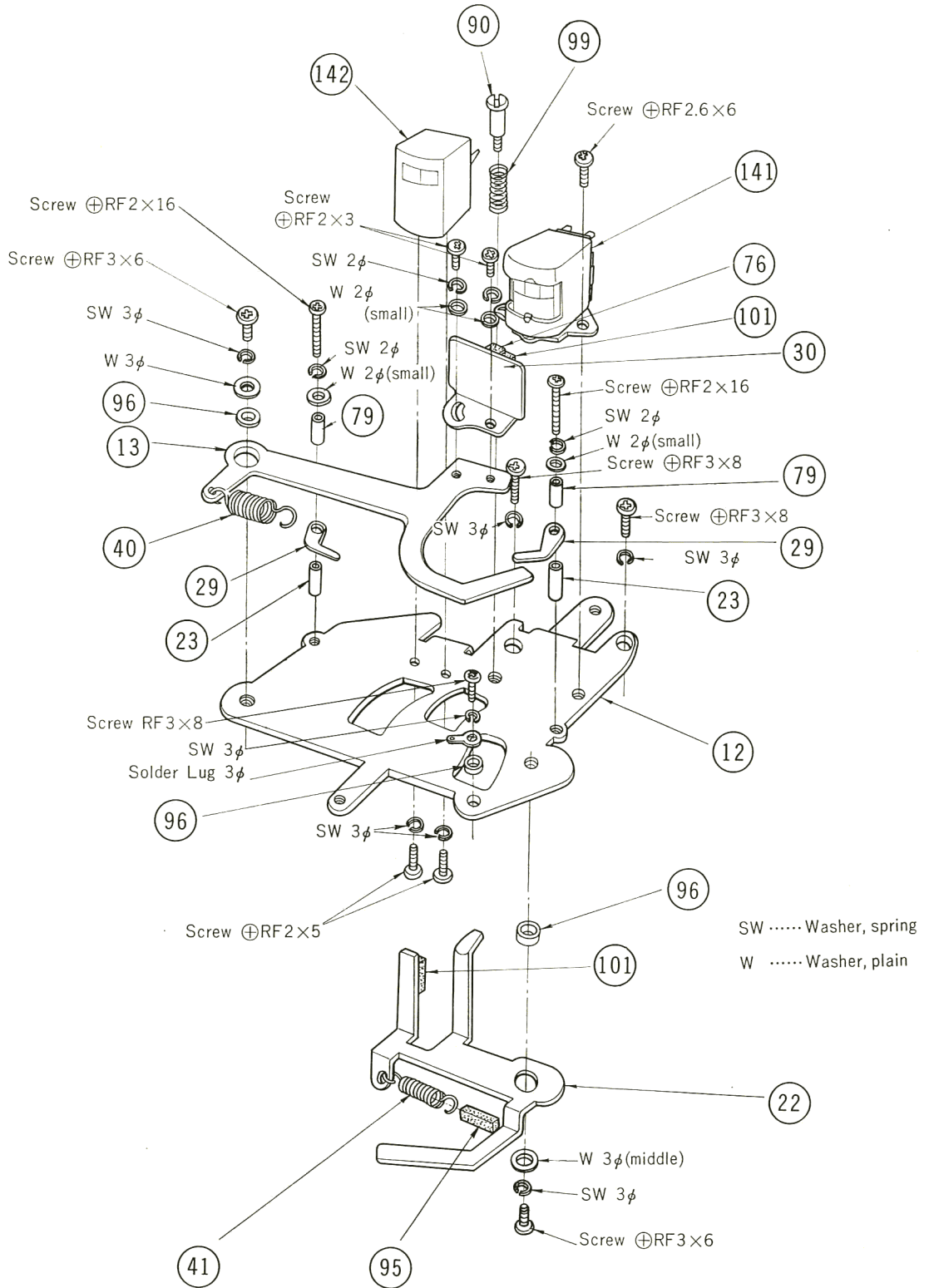

Exploded Diagram

(4)

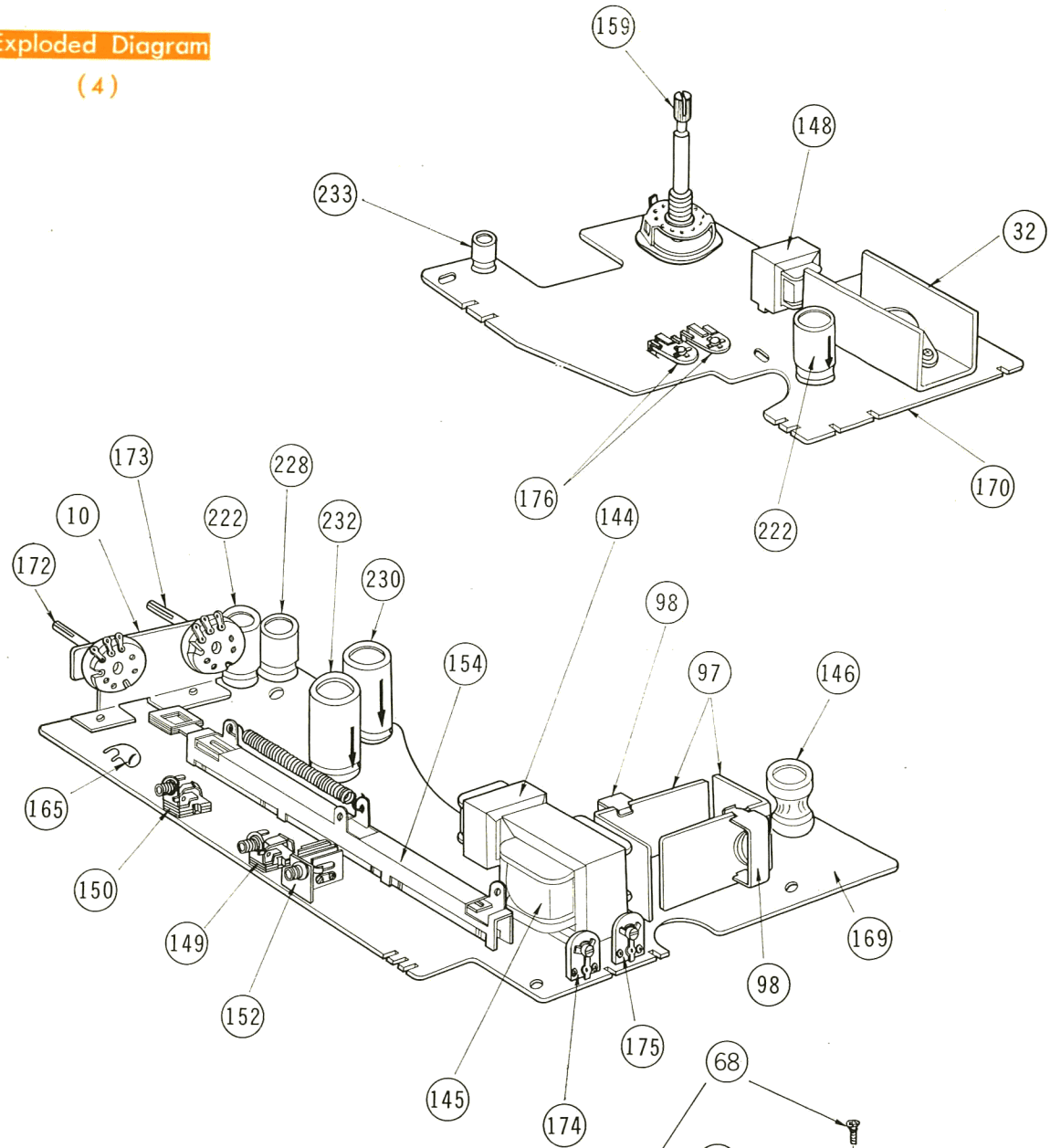

Exploded Diagram

(5)-1

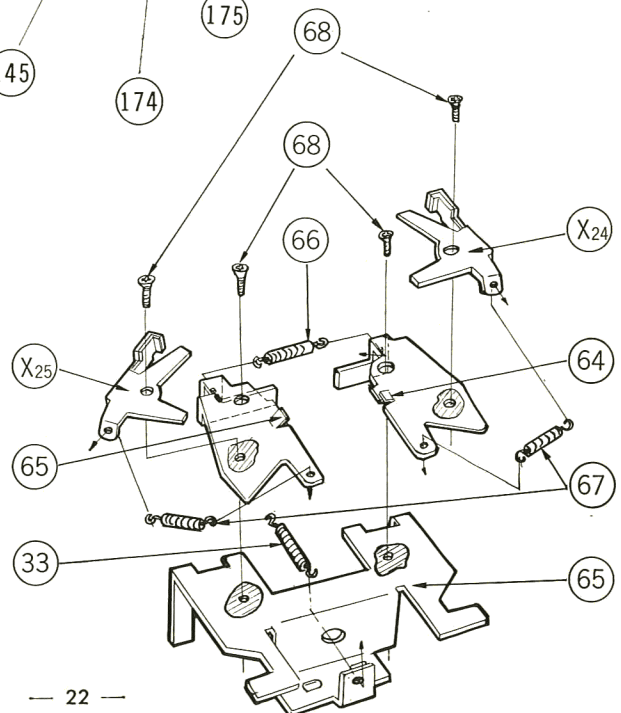

Exploded Diagram

(5) — 2

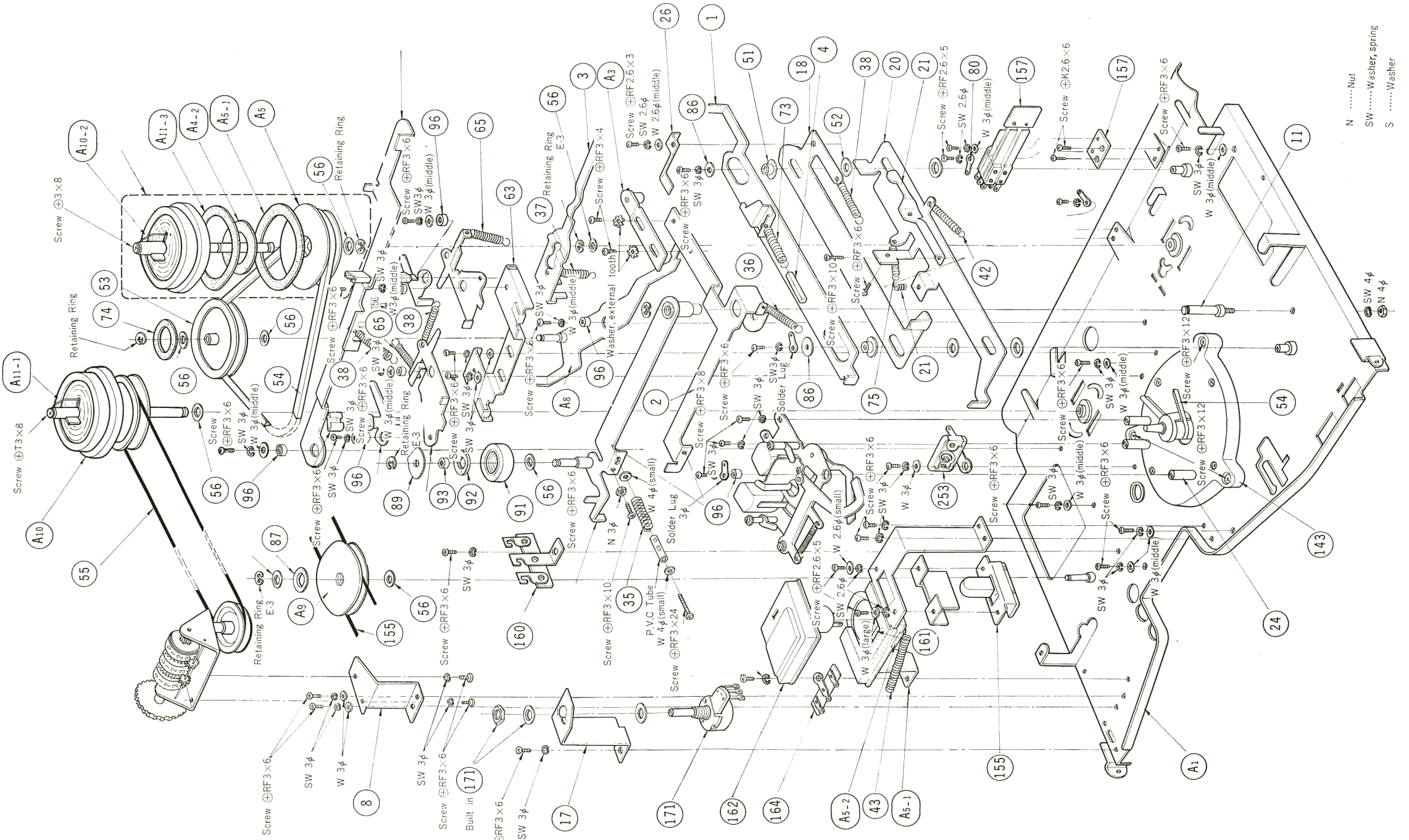

NNut
SWWasher, Spring
SWasher

