

TC-777M



TABLE OF CONTENTS

	Page
Specifications	2
Technical Feature	3
Block Diagram	3
Cabinet Top View	4
Cabinet Side View	5
Chassis Top View	6
Chassis Bottom View	7
Method of Disassembling the Set	8
Mechanical Adjustment	9
Electrical Adjustment	10-12
Modification to Different Power Line Frequency	13
Modification to CCIR Standard from NAB Standard	13
Modification for External Speaker of 16Ω Voice Coil Impedance	13
Level Diagram	14
Mounting Diagram • Relay Board -- Conductor Side--	15
Mounting Diagram • Relay Board --Component Side--	16
Schematic Diagram • Amplifier Section	17-18
Schematic Diagram • Tape Transport Section	19-20
Mounting Diagram • Power Supply & Bias OSC Board --Conductor Side--	21
Mounting Diagram • Power Supply & Bias OSC Board --Component Side--	22
Mounting Diagram • Pre-Amplifier Board --Conductor Side--	23
Mounting Diagram • Pre-Amplifier Board --Component Side	24
Mounting Diagram • Power Amplifier Board --Conductor Side	25
Mounting Diagram • Power Amplifier Board --Component Side	26
Exploded Diagram	27-34

SONY®
VOICE MANUAL

Specifications

Power Requirements: AC 50/60 Hz, 100, 110, 117, 220
or 240 Volts, 90 Watts (Voltage
Selector provided in the Set)

Tape Speeds: 7½ ips & 3¾ ips
(19 cm/s & 9.5 cm/s)
Instantaneous Selection

Recording System: Dual Monophonic

Reel Size: Up to 7" (18 cm)

Frequency Response: 30~17,000 Hz at 7½ ips (19 cm/s)
30~10,000 Hz at 3¾ ips (9.5 cm/s)

Signal-to-Noise Ratio: Better than 50 dB (at peak recording
level)

Harmonic Distortion: Less than 3% (at normal recording
level)

Flutter and Wow: Less than 0.15% at 7½ ips

Power output: Max 3W across 8Ω load

Bias Frequency: Approx. 92 kHz

Head Arrangement: EF-3; 2 Track Erase Head
RP15-03; 2 Track Record Head
PP15-04L; 2 Track Playback Head

Motors: HC-634D-4; Capstan
IC-524R₁; Reel
IC-524R₁; Reel

Input: Microphone 2
Low Impedance (600Ω)
-65 dBs (0.44 mV)
Line 1
High Impedance (100kΩ)
-12 dBs (0.2 V)

Output: Line 1
Low Impedance (600Ω)
0 dBs (0.775 V)
External Speaker 1
Voice Coil Impedance 8~16Ω
Monitor 1
High Impedance (10 kΩ)
0 dBs (0.775 V)
Rec./P.B. Connector 1
High Impedance (10 kΩ)
0 dBs (0.775 V)

Transistors: 19

Diodes: 3

Dimensions: 16¼ (W) × 10¼ (H) × 18¾" (D)
(412 (W) × 260 (H) × 477 (D) mm)

Weight: 42 lbs (19 kg)

Technical Feature

GENERAL DESCRIPTION

SONY Model TC-777M Monaural Tape Recorder is high quality precision instrument for professional use provided with three Heads, three Motors, all Transistor (including 5 Silicon Transistors) Amplifier and perfect push button operating system.

SONY Model TC-777M is provided with NAB & CCIR Standard Equalizer Circuits. The Circuit can be modified by changing the connection of the four tinned copper wires with soldering iron, and by readjusting the Adjustable Resistor R_{221} and Record Equalizer Coil L_{201} (See Page 13).

Block Diagram

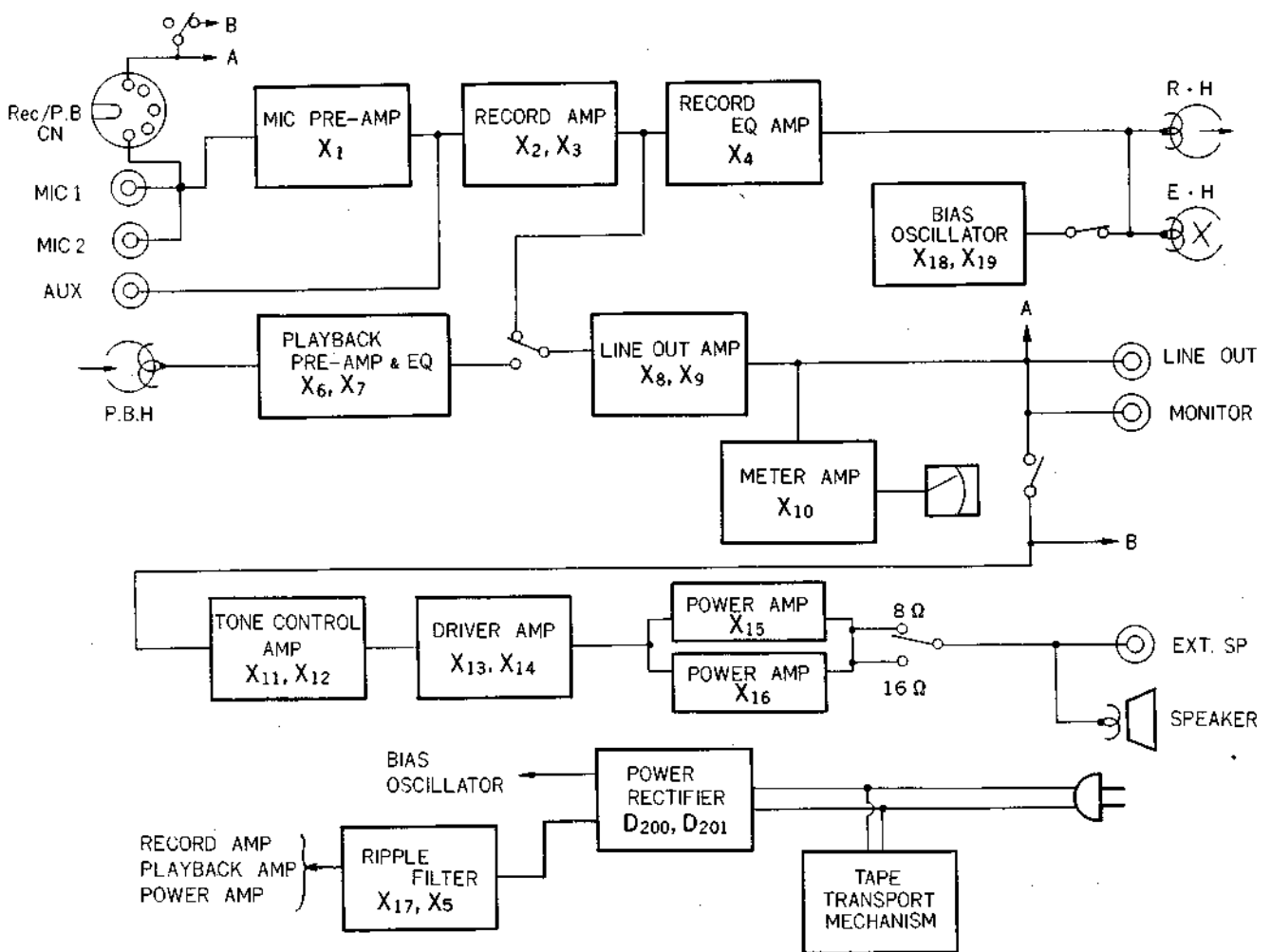

(Fig.1)

Consistent Superior Sound

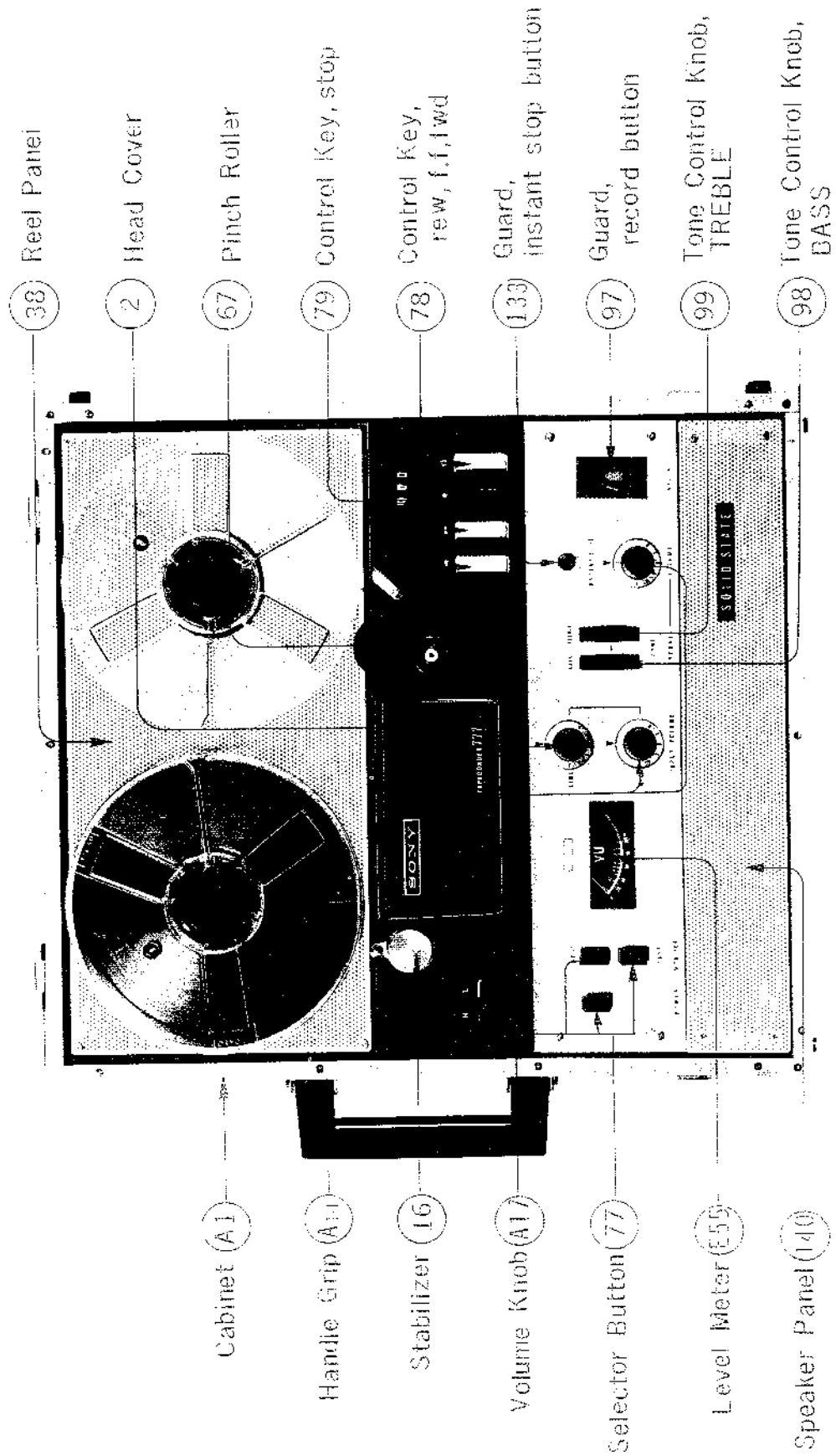

(Fig. 2)

SECRET

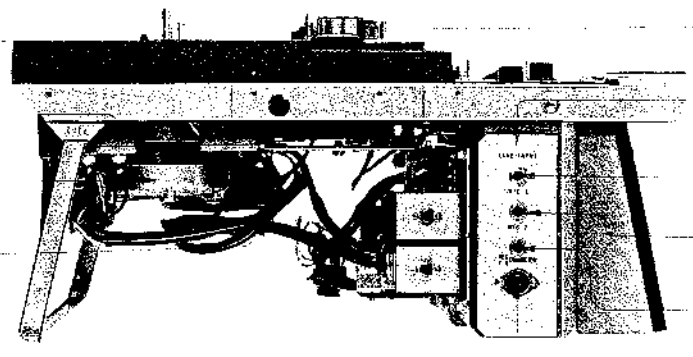

Fig. 3

(Fig. 3)

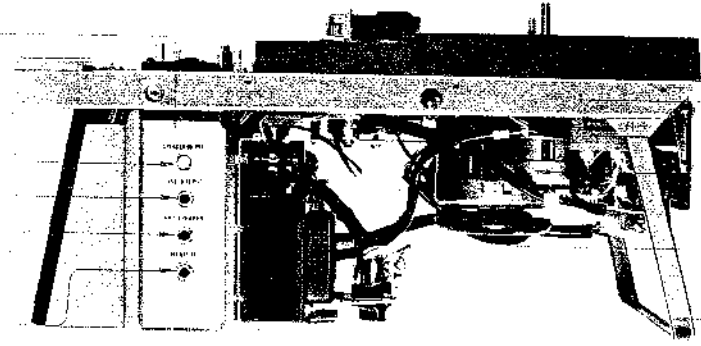

Fig. 4

(Fig. 4)

(48) Brake spring

(49) Brake spring

(A9) Foot table

(E39) Micro Switch (Sanyo)

(A6) Brake Brake

(A10) Tension bar

(E31) Player's board pickup coil

(96) Guard board button

(S) Potentiometer, tone control, IRECO 400 ohm, 500k
 Potentiometer, tone control, IRECO 400 ohm, 500k
 Potentiometer, tone control, IRECO 400 ohm, 500k

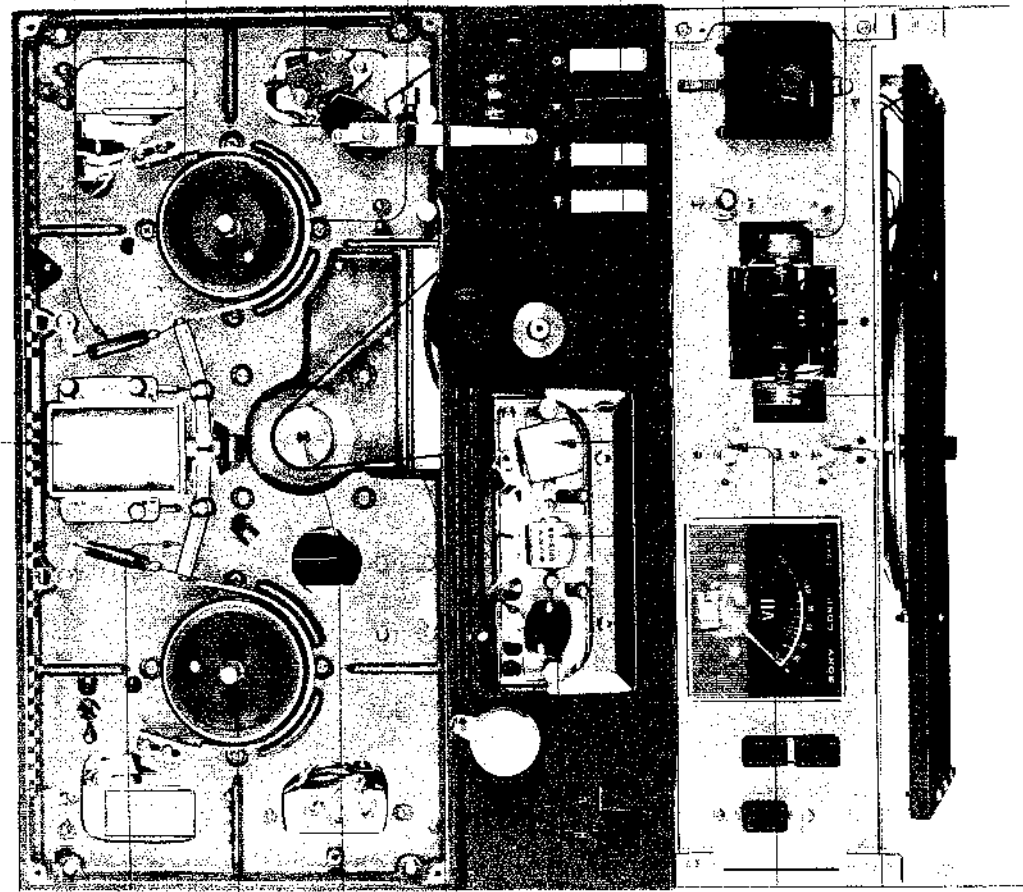

Front panel (1)

Brake arm (2)

Coil (3)

Brake (4)

Control bar (5)

Brake (6)

Brake (7)

Potentiometer, tone control, IRECO 400 ohm, 500k

Potentiometer, tone control, IRECO 400 ohm, 500k

(Fig. 5)

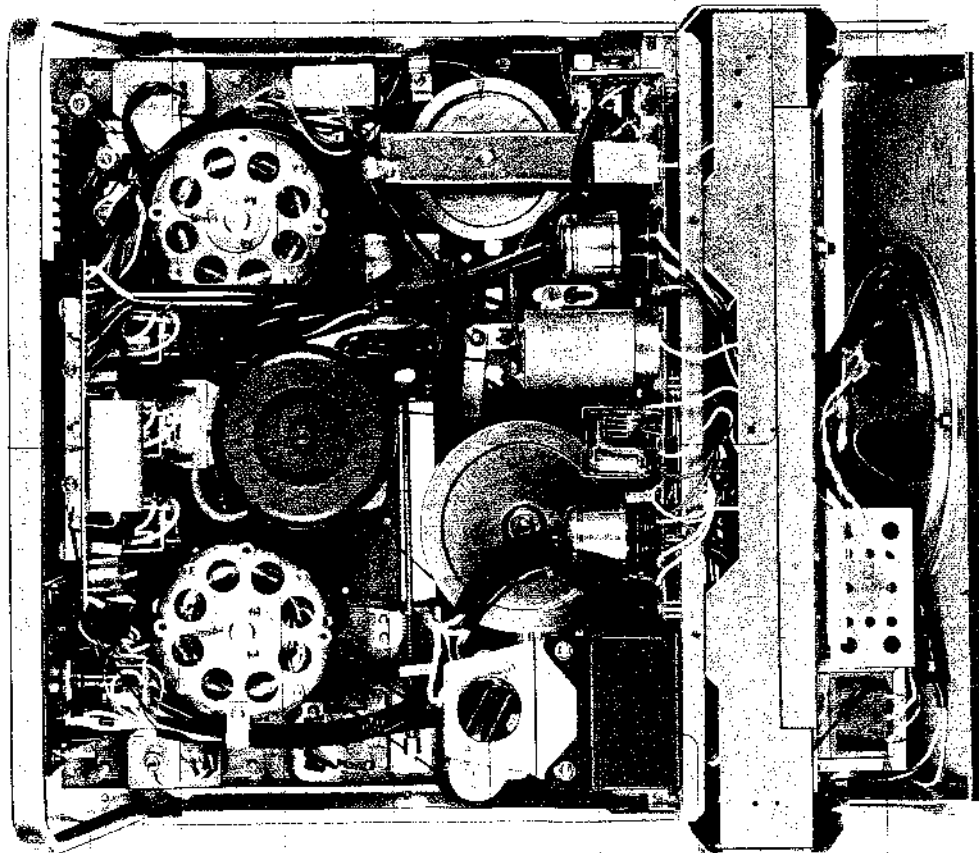

(1) Antenna

(2) Tuning Indicator

(3) Volume Control

(4) Tuning Knob

(5) Tuning Knob

(6) Tuning Knob

(7) Tuning Knob

(8) Tuning Knob

(9) Tuning Knob

(10) Tuning Knob

(11) Tuning Knob

(12) Tuning Knob

(13) Tuning Knob

(14) Tuning Knob

(15) Tuning Knob

(16) Tuning Knob

(17) Tuning Knob

(Fig. 6)

REAR PANEL AND CABINET

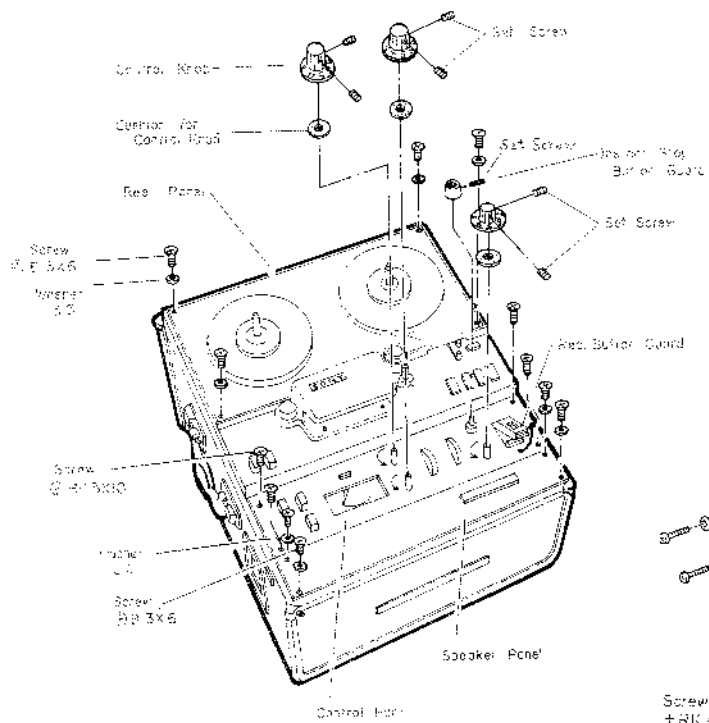

(Fig. 7)

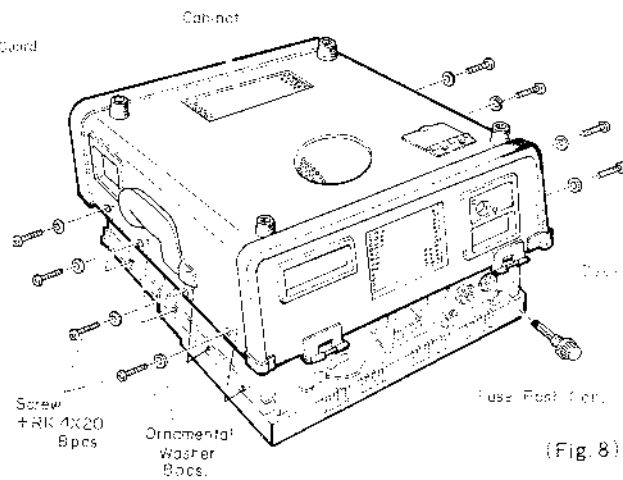

(Fig. 8)

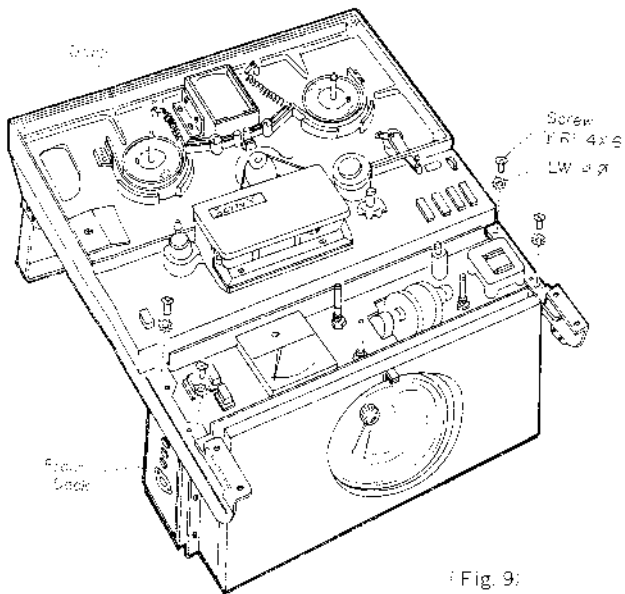

(Fig. 9)

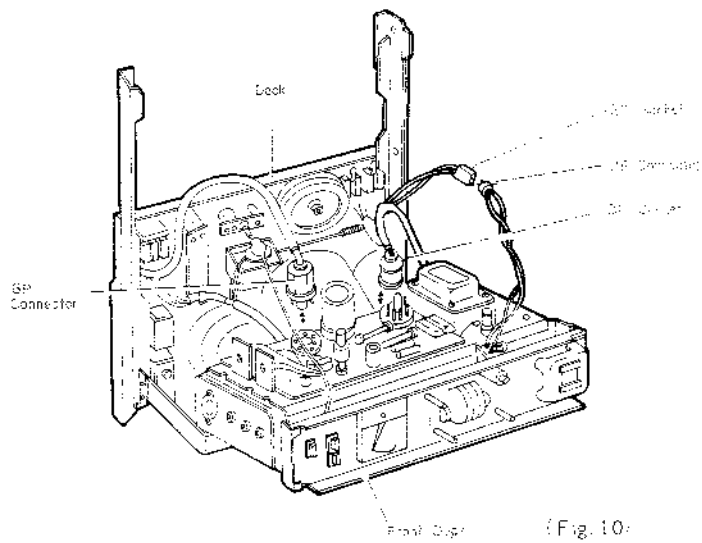

(Fig. 10)

Brake Adjustment

When the machine is set to Stop Mode from other Mode, or after replacing a Brake Band, if the brake function is loose, adjust as follows: (Refer to Fig 11)

- (1) Set the Recorder in Playback Mode (Brake Solenoid Plunger is pulled)
- (2) Loosen two Screws : RF 3/6 marked with and : RF 3/8 marked with
- (3) Adjust the Spacing between the Brake Drum and Felt Lining to approximately 1.25 inch (1 mm) by sliding the brackets.
- (4) Loosen one Screw +RF 4x10 marked with in Fig. 11 of the Take-up side and move the Spring Holder Lug to upper side.
- (5) Place a Test Hub (or empty reel with 44 mmφ hub) connected to Tension Gauge on Take-up Reel Table and pull the Tension Gauge.
- (6) Reading on the Tension Gauge should be approximately 4 lb 14 oz (2.2 kgs)—Torque: 67.5 oz-inch (4.840 gr-cm)
- (7) Adjust Feed Reel side in the same way as Take-up side.

Tape Holdback and Take-up Tension Adjustment

Tape holdback and take-up tensions are adjusted by the sliding contact on the Resistor R₃₀₃ (upper side is for 50 Hz and lower side is for 60 Hz) located on the base plate above the Feed Reel Motor.

- (1) Place a Test Hub (or empty reel with 44 mmφ hub) connected to Tension Gauge on Feed Reel Table.
 - (2) Set the recorder in Playback Mode and read the Tension Gauge while pulling it.
 - (3) Tension Gauge should indicate 10.6 oz (300 grs). --Torque: 9.2 oz-inch (660 gr-cm)
- If the specified value is not obtained, adjust R₃₀₃.

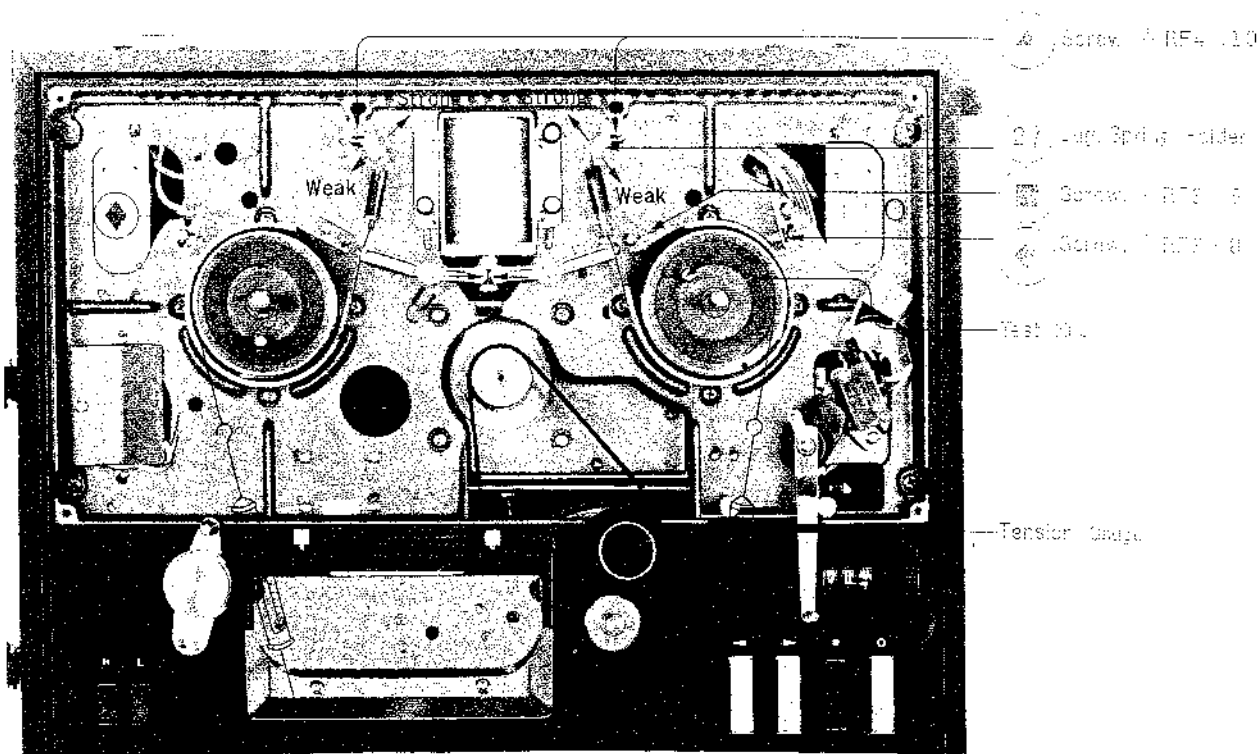

(Fig.11)

1. Playback Head Azimuth Alignment (Refer to Fig.12)

Switch Setting:

- (1) Speed Selector Switch High
- (2) Monitor Switch..... Tape

Procedure:

- (1) Connect a V.T.V.M. and a 100 kΩ Resistor in parallel to Line Output Jack.
- (2) Playback a 12 kHz signal recorded on the 2nd Section of the SONY Alignment Tape (Type: N-19-K).
- (3) Adjust the Azimuth Alignment Screw located on the right side of the Playback Head to obtain a maximum reading on the V.T.V.M.

2. Erasing Current Adjustment (Refer to Fig.4)

Switch Setting:

- (1) Speed Selector Switch Either
- (2) Monitor Switch..... Either

Procedure:

- (1) Connect a 1Ω Resistor in SERIES to Erase Head and a V.T.V.M. across 1Ω Resistor.
- (2) Place the set in Record Mode.
- (3) Adjust the Wire Wound Resistor R₂₆₇ (Erase Head Current Adj.) to obtain a reading of 1V on the V.T.V.M.

3. Record Head Azimuth Alignment (Refer to Fig.12)

Switch Setting: the same as Playback Head Azimuth Alignment

Procedure:

- (1) Connect a V.T.V.M. and a 100 kΩ Resistor in parallel to Line Output Jack.
- (2) Feed a 12 kHz of -30 dBs (24.5 mV) to Line Input Jack.
- (3) Thread a blank tape, record the signal and playback it.
- (4) Adjust the Azimuth Alignment Screw located on the right side of the Record Head to obtain a maximum reading on the V.T.V.M.

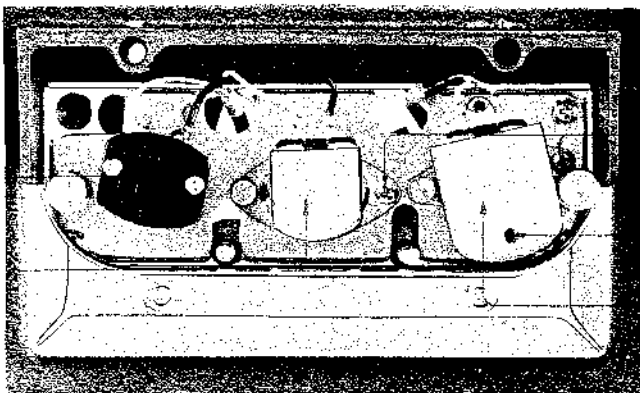

- ① Azimuth Alignment Screw
- ② Azimuth Alignment Screw
- ③ Azimuth Alignment Screw
- ④ Azimuth Alignment Screw

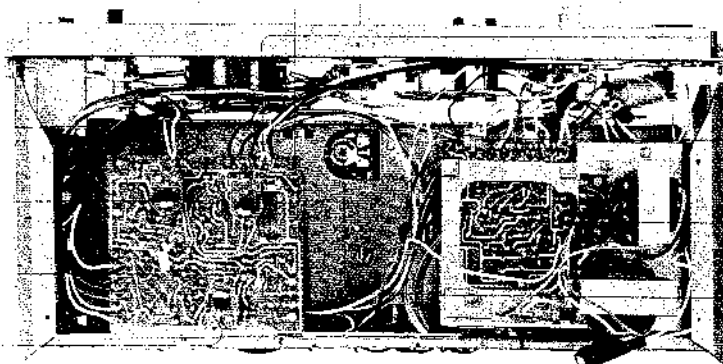

- ① Power Amplifier
- ② Power Amplifier
- ③ Power Amplifier
- ④ Power Amplifier

4. Playback Output Level Adjustment and Meter Calibration (Refer to Fig. 13)

Switch Setting:

- (1) Speed Selector Switch High
- (2) Monitor Switch..... Tape

Procedure:

- (1) Connect a V.T.V.M. and a 100 k Ω Resistor in parallel to Line Output Jack.
- (2) Playback a 700 Hz signal recorded on the 2nd Section of the SONY Alignment Tape (Type: N-19-F₂).
- (3) Adjust the Adjustable Resistor R₁₃₂ (PB Level Adj.) located on Pre-Amplifier circuit board so that Line Output Level is 0 dBs (0.775 V), and also adjust the Adjustable Resistor R₁₄₂ (Meter Level Adj.) located on Pre-Amplifier circuit board to obtain a reading of 0 VU (100%) on the Level Meter.

5. Playback Equalizer Adjustment (NAB Standard) (Refer to Fig. 13)

Switch Setting: Same as Playback Output Level Adjustment

Procedure:

- (1) Connect a V.T.V.M. and a 100 k Ω Resistor in parallel to Line Output Jack.
- (2) Playback a 700 Hz signal recorded on the 3rd Section of the SONY Alignment Tape (Type: N-19-F₂).
- (3) Adjust the Adjustable Resistor R₂₂₁ (PB EQ Adj.) located on the Power Supply & Bias OSC board so that Line Output Level is 0 dBs (0.775 V).
- (4) Deviation against the level at 700 Hz of the 3rd Section should be as follows:

Tape Section	4th	5th	6th	7th
	10 kHz	7.5 kHz	100 Hz	50 Hz
Deviation	0 +1 dB -3 dB	0 +1 dB -2 dB	0 \pm 1 dB	0 +1 dB -3 dB

6. Trap Coil Adjustment (Refer to Fig. 13)

Switch Setting:

- (1) Speed Selector Switch High
- (2) Monitor Switch..... Either

Procedure:

- (1) Before adjusting, turn the core of the Trap Coils counter-clockwise to the full.
- (2) Connect a V.T.V.M. across Collector of Transistor X₁ and Ground.
- (3) Place the set in RECORD mode.
- (4) Adjust the Trap Coils, L₁₀₀ located on Pre-Amplifier board and L₂₀₀ located on Power Supply and Bias OSC board to obtain a minimum reading on the V.T.V.M.

Note: While adjusting, R₂₀₄ (Noise Balance Adj.) located on Power Supply and Bias OSC board should be kept to the mechanical mid position.

7. Recording Bias Adjustment (Refer to Fig. 3)

Switch Setting:

- (1) Speed Selector Switch High
- (2) Monitor Switch Input

Procedure:

- (1) Connect a V.T.V.M. and a 100 k Ω Resistor in parallel to Line Output Jack.
- (2) Feed a 1 kHz of -10 dBs (0.245 V) signal to Line Input Jack and thread a blank tape.
- (3) Place the set in RECORD Mode and adjust the Potentiometer VR₁₀₁ (LINE VOL) so that VU Meter indicates 0 VU (100%).
- (4) Record the signal.
- (5) Set the Monitor Switch to TAPE position.
- (6) Turn the Adjustable Resistor R₂₁₃ (Bias Adj.) located on the Power Supply & Bias OSC board clockwise slowly, then V.T.V.M. reading will go up and reaching a maximum, and then falling again. Continue to turn the Adjustable Resistor R₂₁₃ until the V.T.V.M. reads 0.5 dB below the maximum reading.

8. Recording Level Adjustment (Refer to Fig. 13)

Switch Setting:

- (1) Speed Selector Switch High
- (2) Monitor Switch Input

Procedure:

- (1) Connect a V.T.V.M. and a 100kΩ Resistor in parallel to Line Output Jack.
- (2) Feed a 1 kHz of -60 dBs (0.775 mV) to MIC Input Jack.
- (3) Thread a blank tape and record the signal.
- (4) Set the Monitor Switch to TAPE Position.
- (5) Adjust the Potentiometer VR₁₀₀ (MIC VOL) to obtain a reading of 0 dBs (0.775 V) on the V.T.V.M.
- (6) Set the Monitor Switch to INPUT position.
- (7) Adjust the Adjustable Resistor R₁₁₉ (Rec. Level Adj.) located on Pre-Amplifier board to obtain a reading of 0 VU (100%) on the Level Meter.

9. Noise Balance Adjustment

Switch Setting:

- (1) Speed Selector Switch High
- (2) Monitor Switch Input

Procedure:

- (1) Connect a V.T.V.M. and a 100kΩ Resistor in parallel to Line Output Jack.
- (2) Turn the Potentiometer VR₁₀₀ (MIC VOL) to the minimum.
- (3) Thread a blank tape and set in RECORD Mode.
- (4) Set the Monitor Switch to TAPE Position.
- (5) Adjust the Adjustable Resistor R₂₀₈ (Noise Balance Adj.) located on Power Supply and Bias OSC board to obtain a reading of less than -48 dBs (3 mV) on the V.T.V.M.

10. Recording Equalizer Adjustment (NAB Standard) (Refer to Fig. 13)

Switch Setting:

- (1) Speed Selector Switch High
- (2) Monitor Switch Input

Procedure:

- (1) Connect a V.T.V.M. and a 100kΩ Resistor in parallel to Line Output Jack.
- (2) Feed a 1 kHz of -60 dBs (0.775 mV) to MIC Input Jack.
- (3) Thread a blank tape and set in RECORD Mode.
- (4) Adjust the Potentiometer VR₁₀₀ (MIC VOL) to obtain a reading of 0 VU (100%) on the Level Meter.
- (5) Feed a 12 kHz of -80 dBs (78 μV) to MIC Input Jack-1 and record it.
- (6) Adjust the Record Equalizer Coil L₂₀₁ (Record EQ Adj.) located on Power Supply & Bias OSC board to obtain a reading of 0 dB~0.5 dB on the V.T.V.M. comparing with 1 kHz level.

Response of other frequency against 1 kHz should be as follows:

Frequency	15 kHz	10 kHz	5 kHz	500 Hz	100 Hz	50 Hz
Deviation	0 +1.5 dB -5 dB	0 ± 1.5 dB	0 ± 1.5 dB	0 ± 1.5 dB	0 ± 1.5 dB	0 +1.5 dB -3.5 dB

11. Speaker Output Level Adjustment (Refer to Fig. 13)

Switch Setting:

- (1) Speed Selector Switch Either
- (2) Monitor Switch Input

Procedure:

- (1) Connect a V.T.V.M. and an 8Ω Resistor in parallel to External Speaker Jack (J₁₀₃).
- (2) Feed 1 kHz of -60 dBs (0.775 mV) to MIC Input Jack-1 and place the set in RECORD Mode.
- (3) Adjust the Potentiometer VR₁₀₀ (MIC VOL) to obtain a reading of 0 VU (100%) on the Level Meter.

- (4) Set the Potentiometer VR₁₀₁ (Speaker VOL) to the maximum position, and also VR₁₀₂ (Speaker Tone Treble) and VR₁₀₃ (Speaker Tone Bass) to the mechanical mid position.
- (5) Place the SW₁₀₁ (Speaker ON/OFF) to the ON position.
- (6) Adjust the Adjustable Resistor R₁₇₁ (Speaker Output Level Adj.) located on Power Amplifier board to obtain a reading of 4.9 V on the V.T.V.M..

Modification to Different Power Line Frequency

	50 Hz	60 Hz
1. Connection between two terminals of the MP Capacitor (C ₃₀₉)	Connected 2.5 μ F	Disconnected 2.0 μ F
2. Motor Pulley	3-404-214-01	3-404-214-02

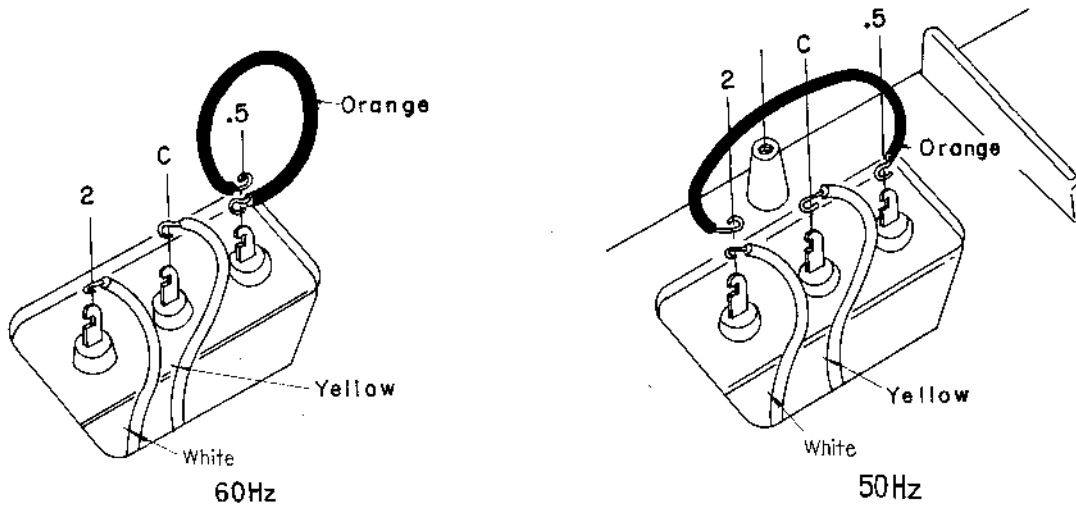

Modification to CCIR Standard from NAB Standard (Refer to Fig. 13)

Before adjustment, change the connection of the four Tinned Copper Wires for PB EQ and REC EQ located on Power Supply & Bias OSC board with soldering iron.

Switch Setting:

- (1) Speed Selector Switch High
- (2) Monitor Switch Tape

Procedure:

- (1) Connect a V.T.V.M. and 100 k Ω Resistor in parallel to Line Output Jack.
- (2) Playback a 1 kHz signal recorded on the 2nd Section of the SONY Alignment Tape (Type: B-19-F₁).
- (3) Adjust the Adjustable Resistor R₁₃₂ (PB Level Adj.) located on Pre-Amplifier circuit board so that Line Output Level is 0 dBs (0.775 V), and also adjust the Adjustable Resistor R₁₁₂ (Meter Level Adj.) located on Pre-Amplifier circuit board to obtain a reading 0 VU (100%) on the Level Meter.
- (4) Playback a 10 kHz signal recorded on the 4th Section of the SONY Alignment Tape (Type: B-19-F₁).
- (5) Adjust the Adjustable Resistor R₂₂₁ (PB EQ Adj.) located on Power Supply & Bias OSC board to obtain a reading 0.5 dB lower than the at 1 kHz.
- (6) Feed a 50 Hz, 100 Hz, 700 Hz, 7.5 kHz and 10 kHz of -75 dBs (0.14 mV) to MIC Input Jack.
- (7) Adjust the Record Equalizer Coil L₂₀₁ (Rec. EQ Adj.) located on Power Supply & Bias OSC board to obtain a reading of 0 dBs (0.775 V) on the V.T.V.M. at both 7 $\frac{1}{2}$ ips (19 cm/s) and 3 $\frac{3}{4}$ ips (9.5 cm/s) speeds.

Modification for External Speaker of 16 Ω Voice Coil Impedance

When using an external speaker of 16 Ω voice coil impedance, change the connection of wire on the Power Amplifier circuit board with soldering iron (See page 25).

Level Diagram

Recording

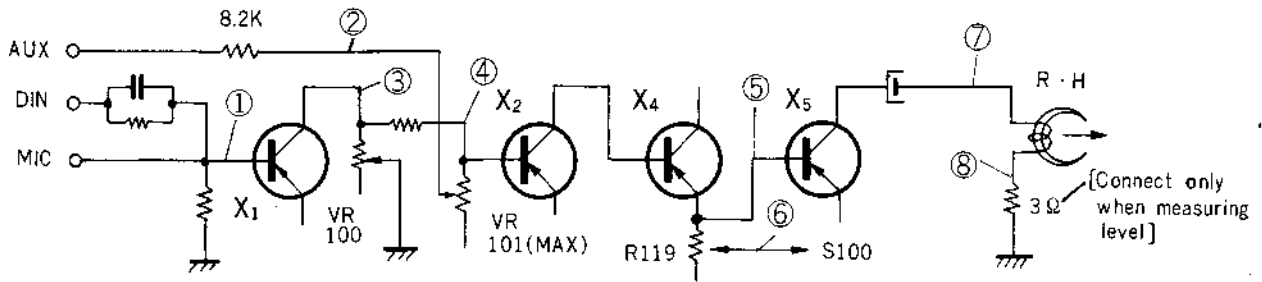
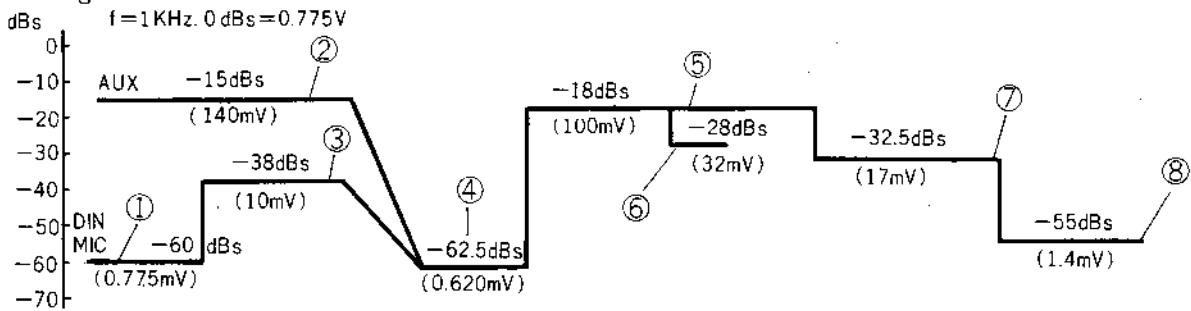

Playback

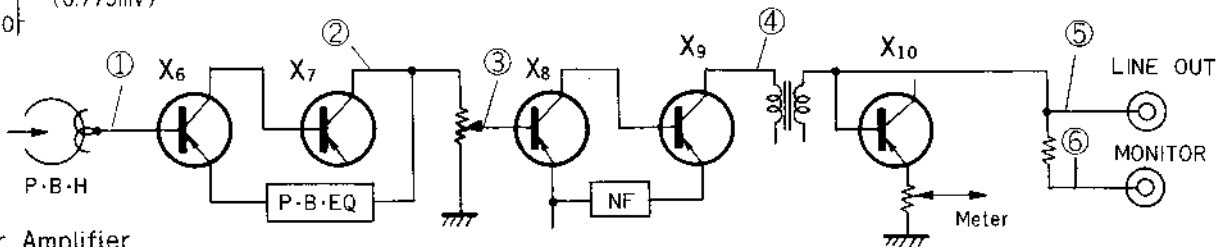
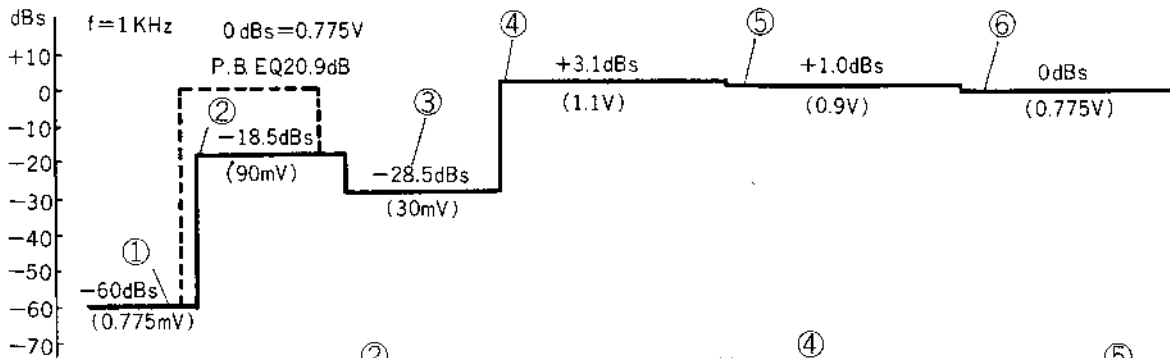

Power Amplifier

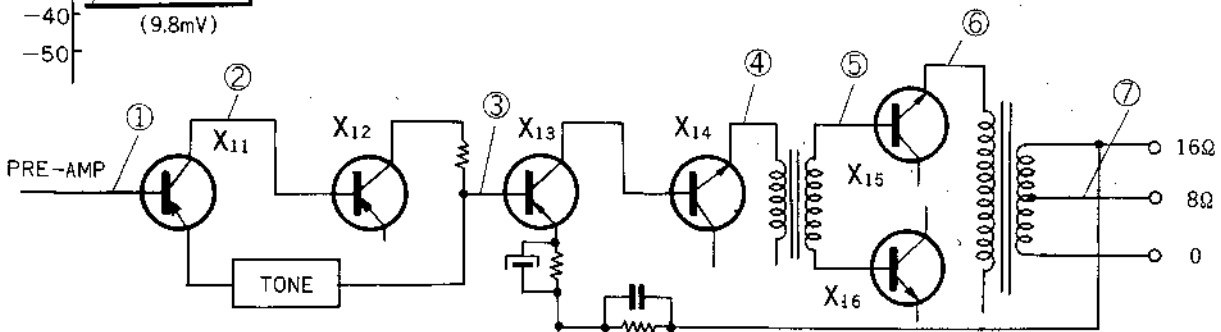
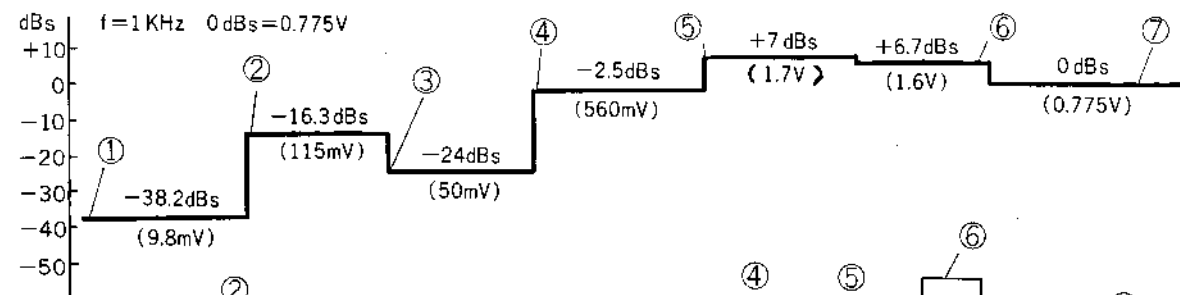

Relay Section

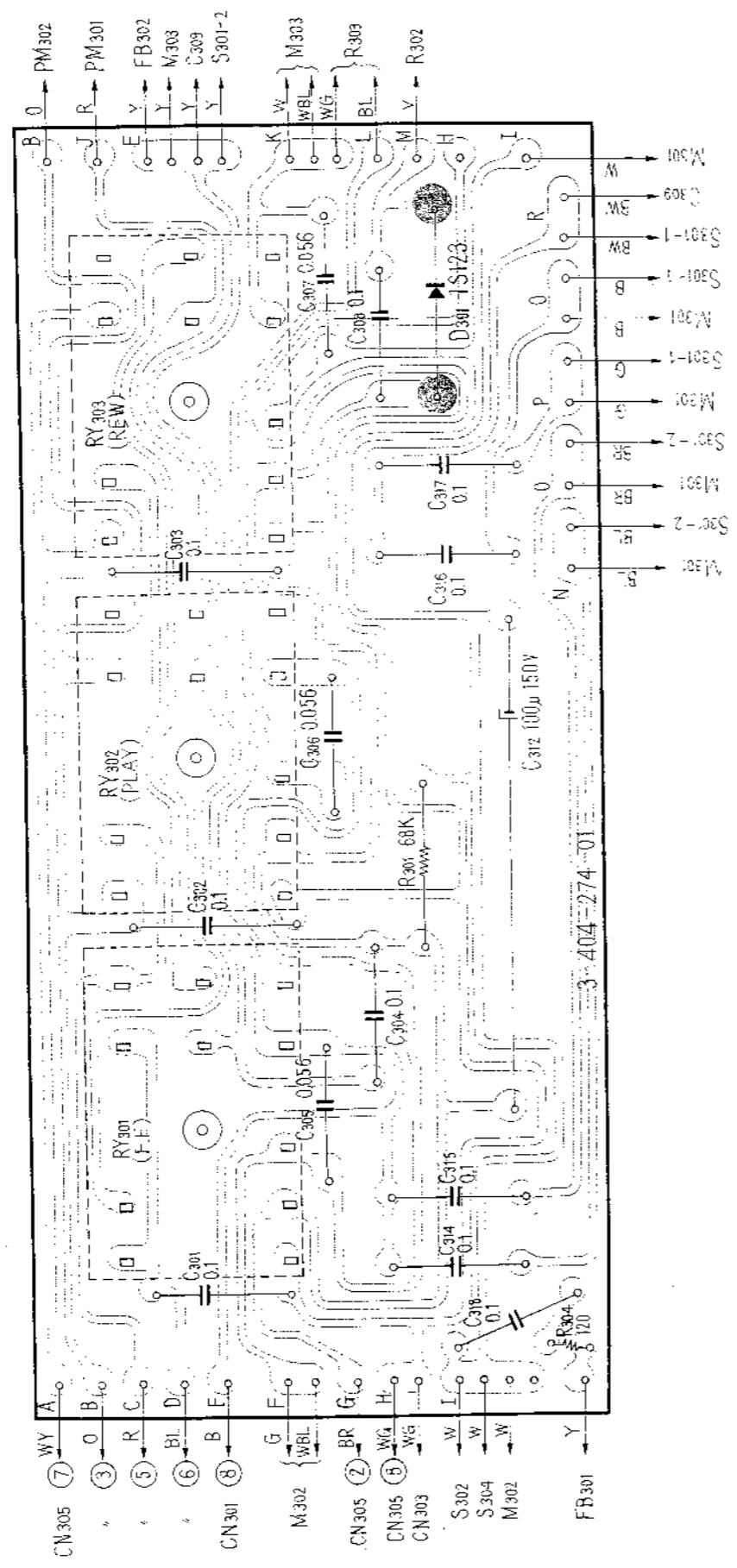

Relay Section

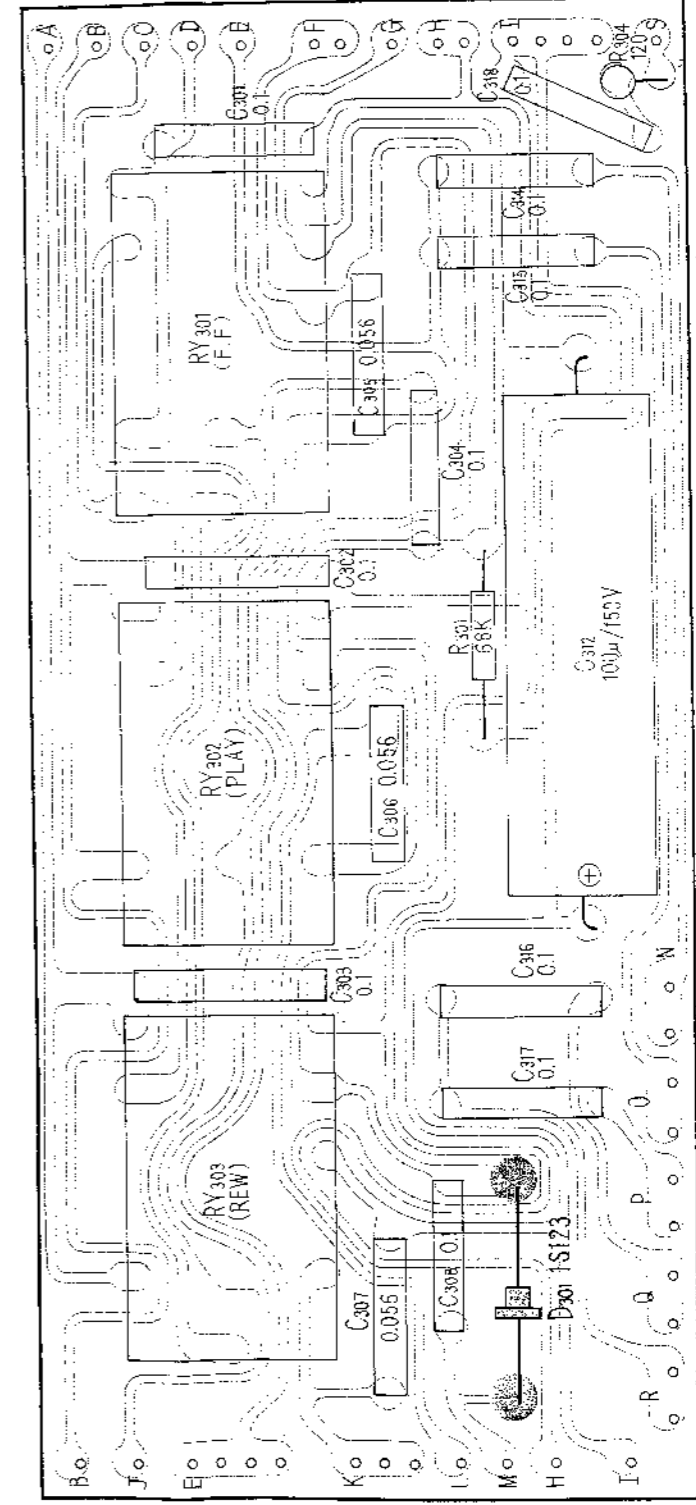

TC-777M TC-777M

Schematic Diagram

Amplifier Section

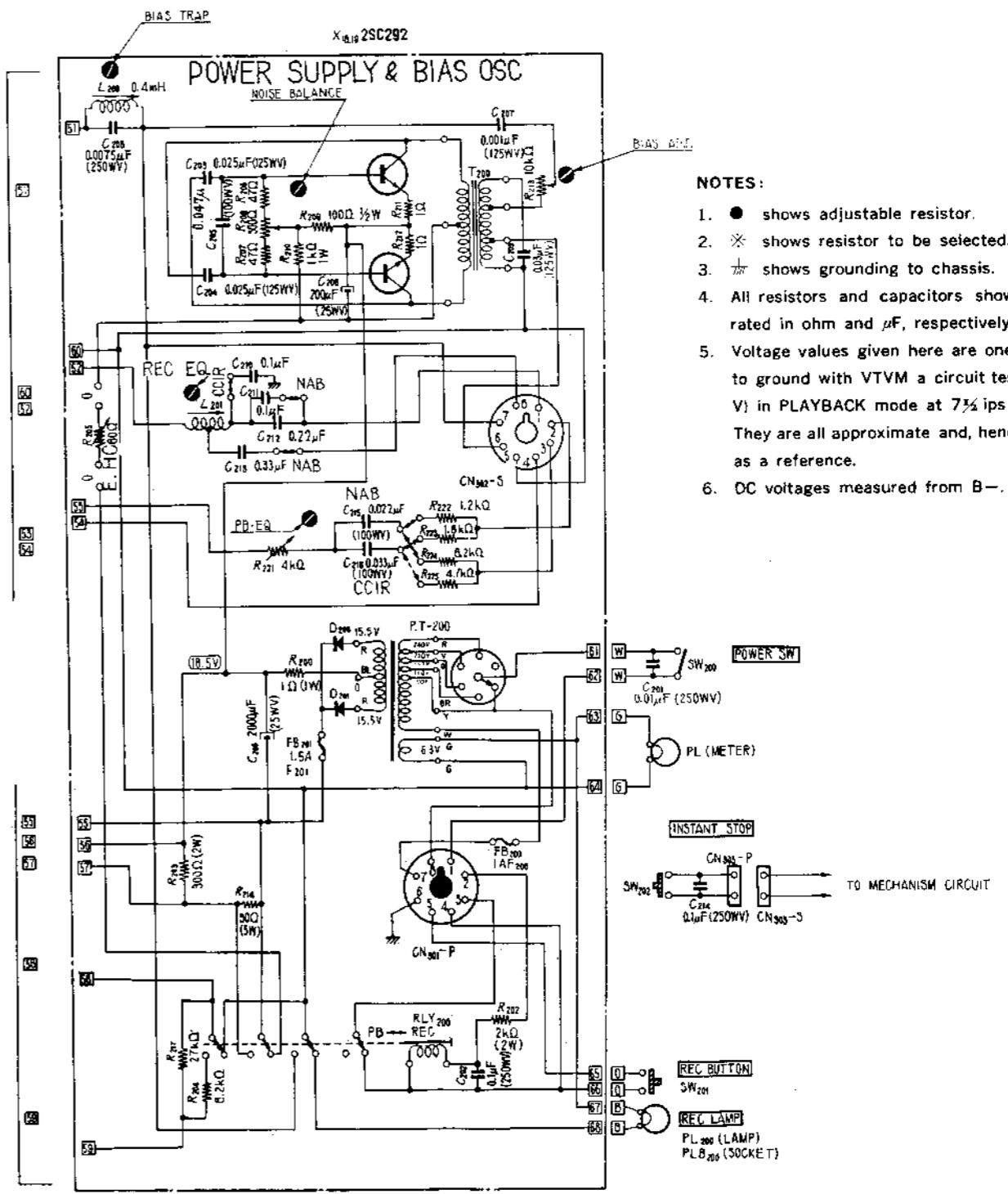
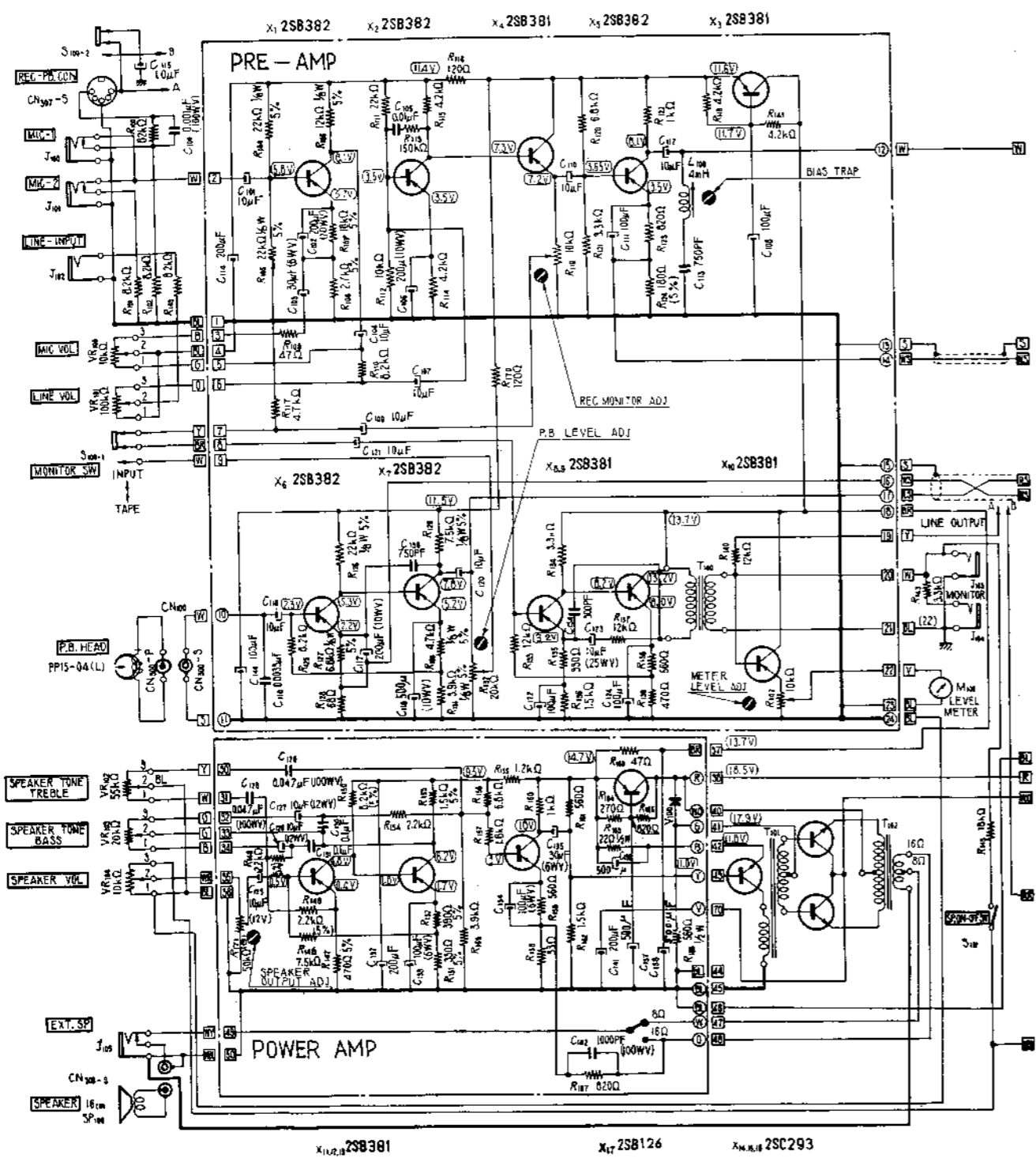

- NOTES:**
- shows adjustable resistor.
 - ⊗ shows resistor to be selected.
 - ⊥ shows grounding to chassis.
 - All resistors and capacitors shown here are rated in ohm and μ F, respectively.
 - Voltage values given here are ones measured to ground with VTVM a circuit tester (20K Ω /V) in PLAYBACK mode at 7½ ips (19 cm/s). They are all approximate and, hence, are given as a reference.
 - DC voltages measured from B-.

TC-777M TC-777M

Schematic Diagram

TAPE TRANSPORT CONTROL CIRCUIT

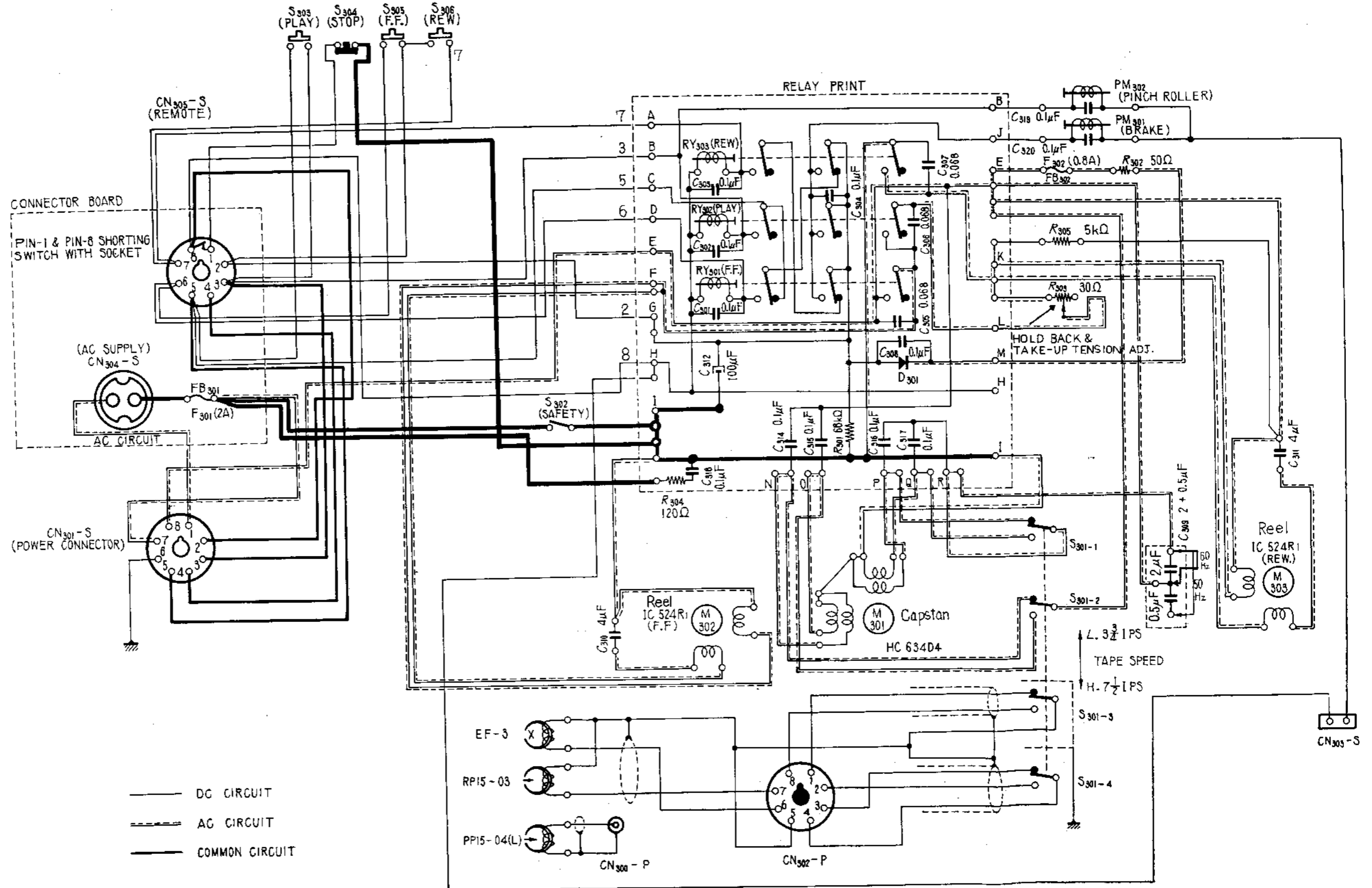

Power Supply & Bias OSC Section
 Conductor Side -

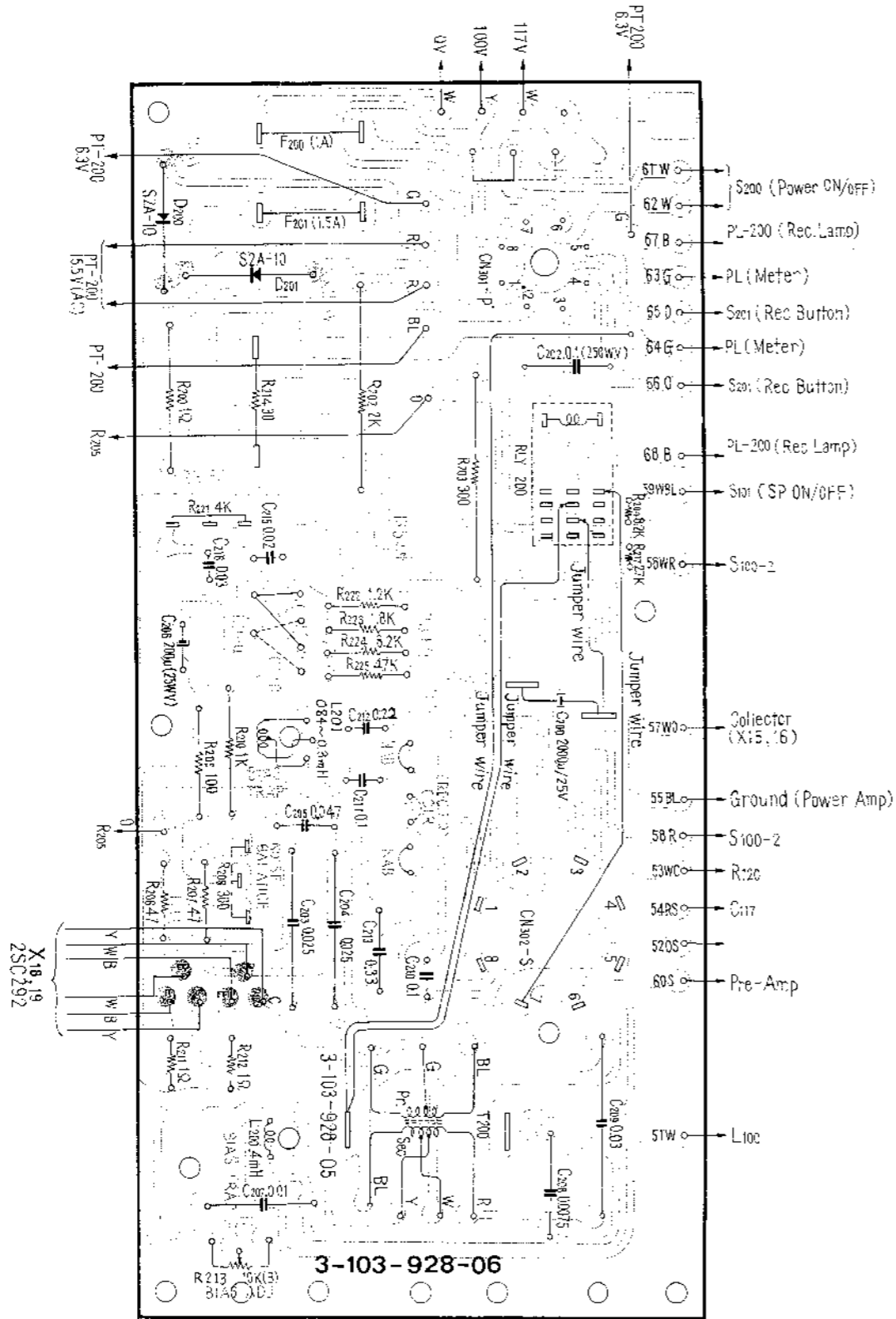

Power Supply & Bias OSC Section
 Component Side -

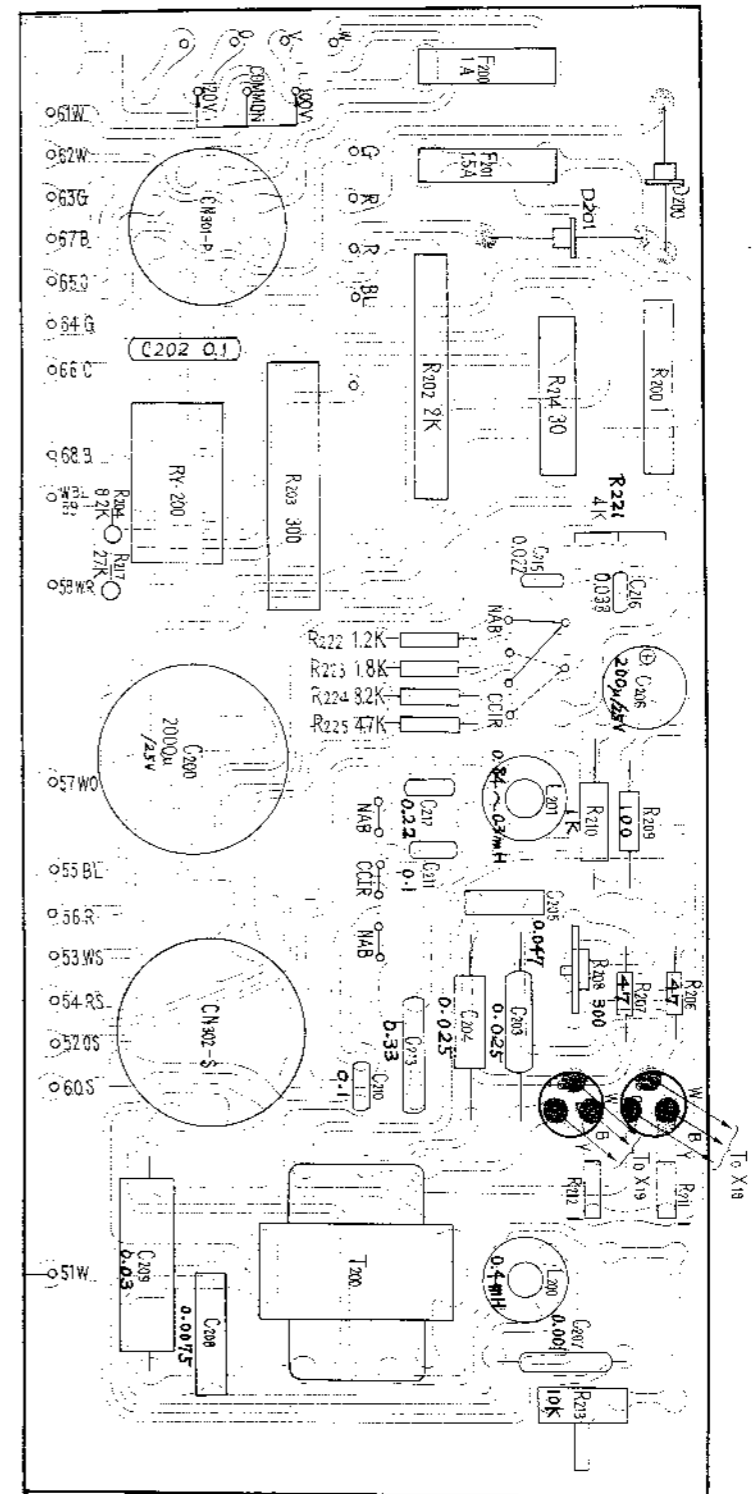

Mounting Diagram

Pre-Amplifier Section
 -Component Side-

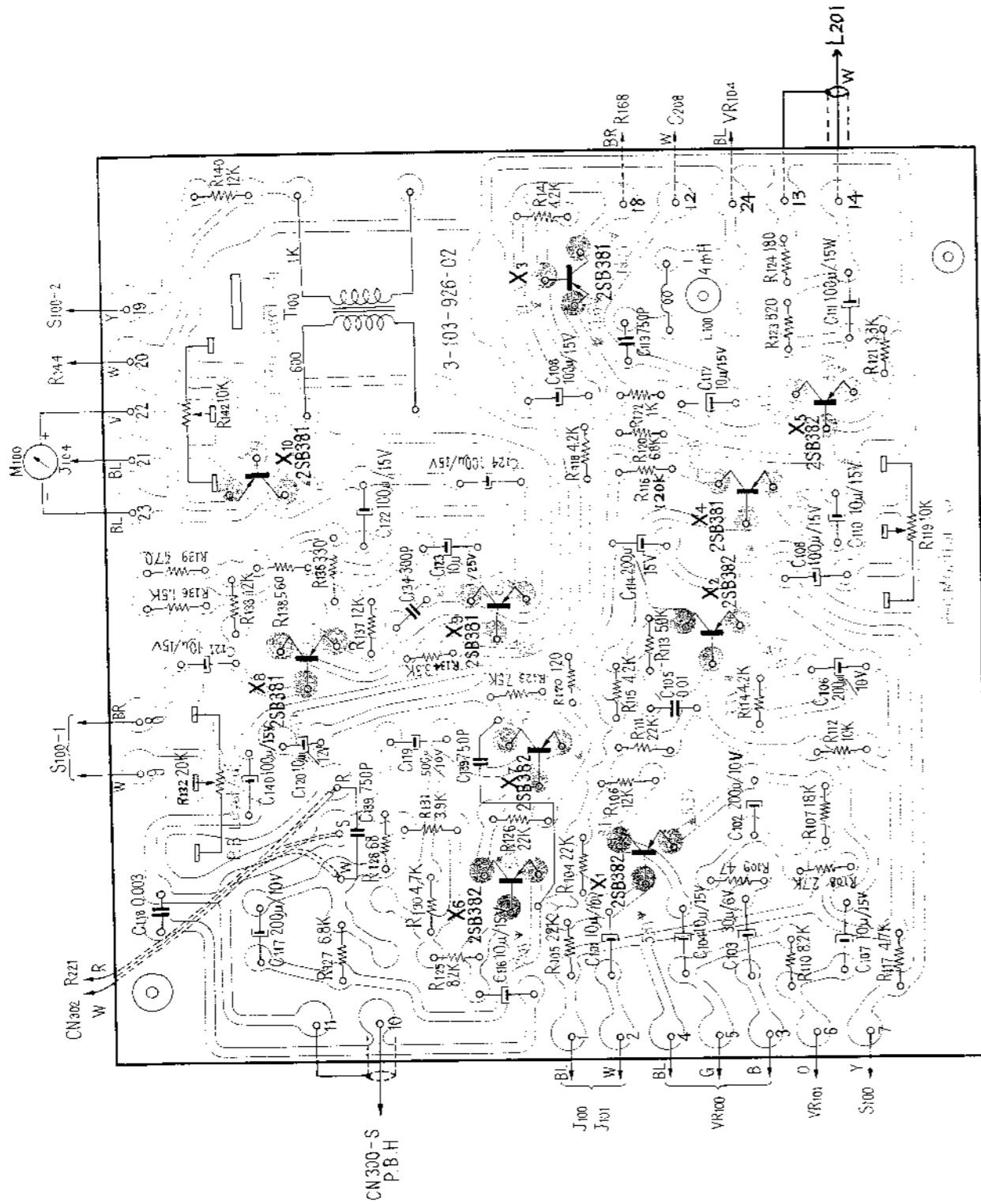

Mounting Diagram

Pre-Amplifier Section
 -Component Side-

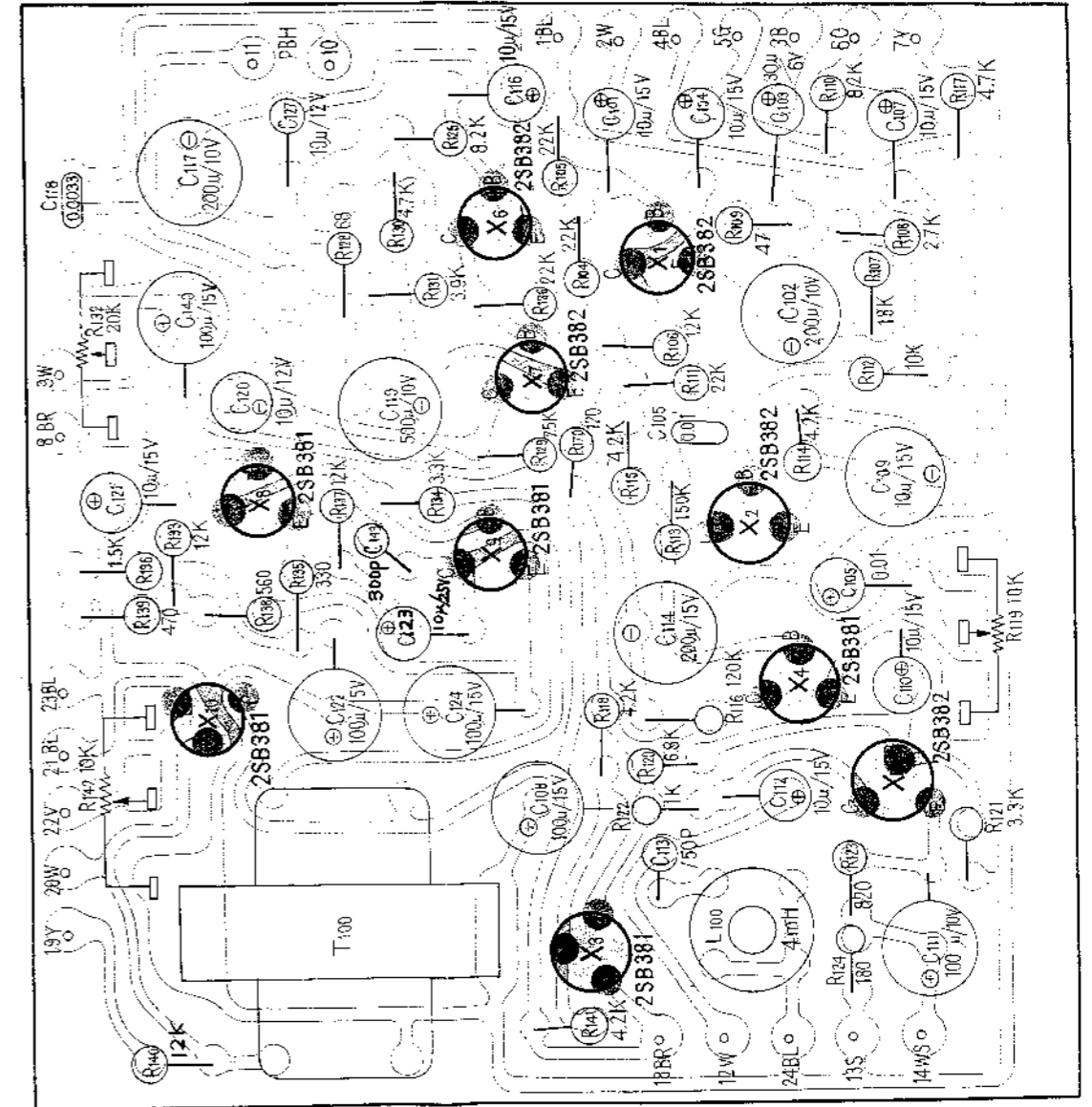

Mounting Diagram

Power Amplifier Board Section
Conductor Side

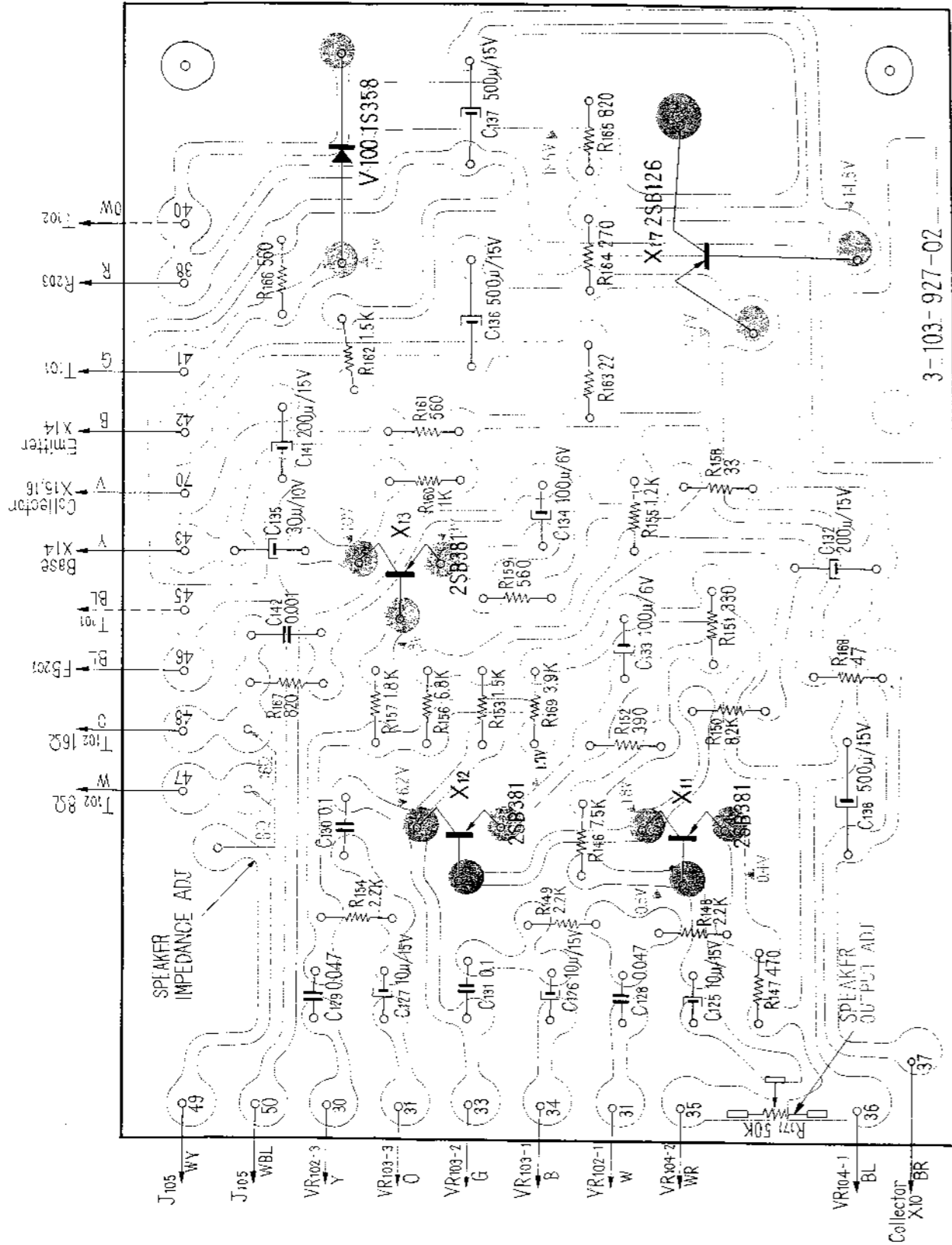

3-103-927-02

Mounting Diagram

Power Amplifier Board Section
Component Side

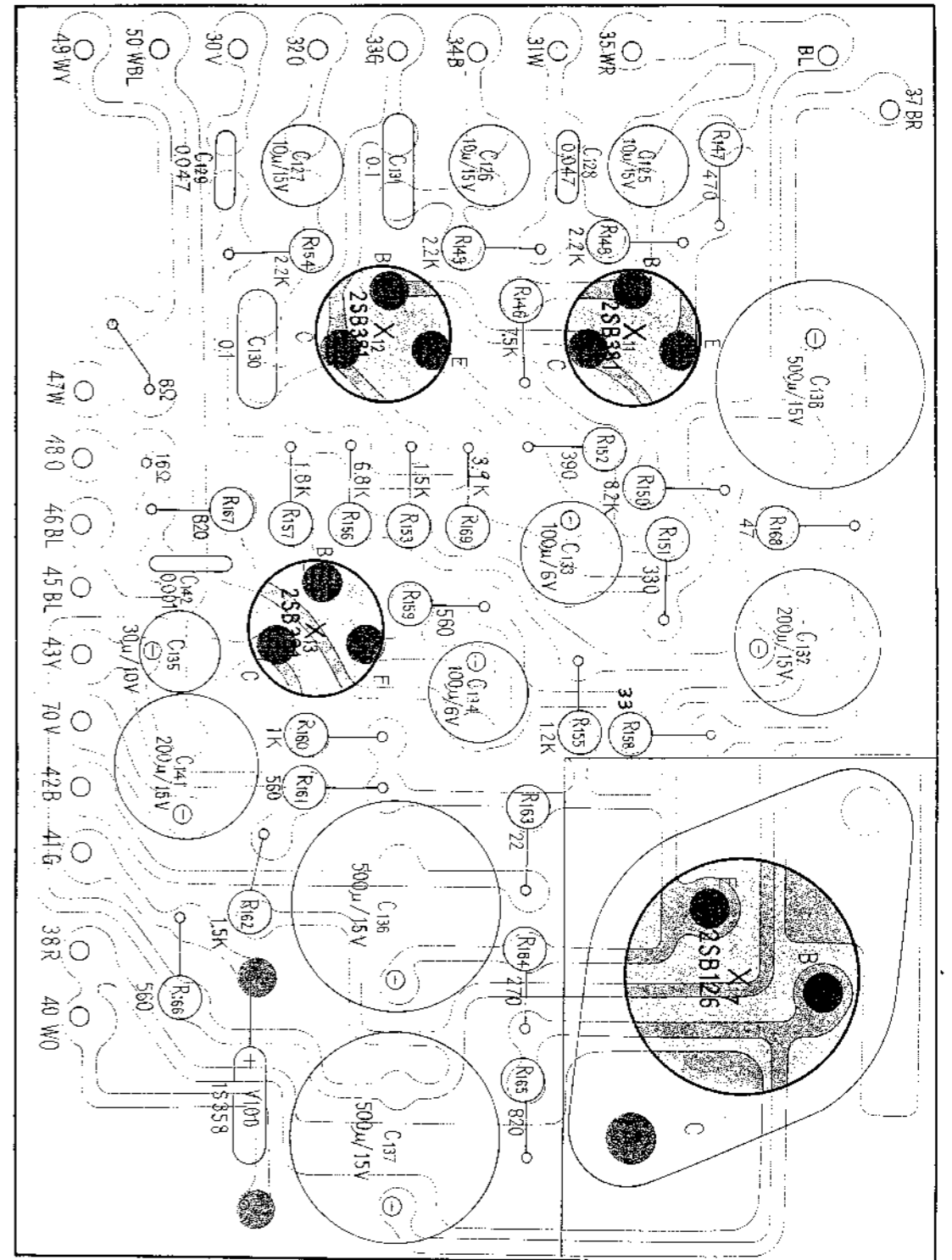

Exploded Diagram
Chassis—Bottom View

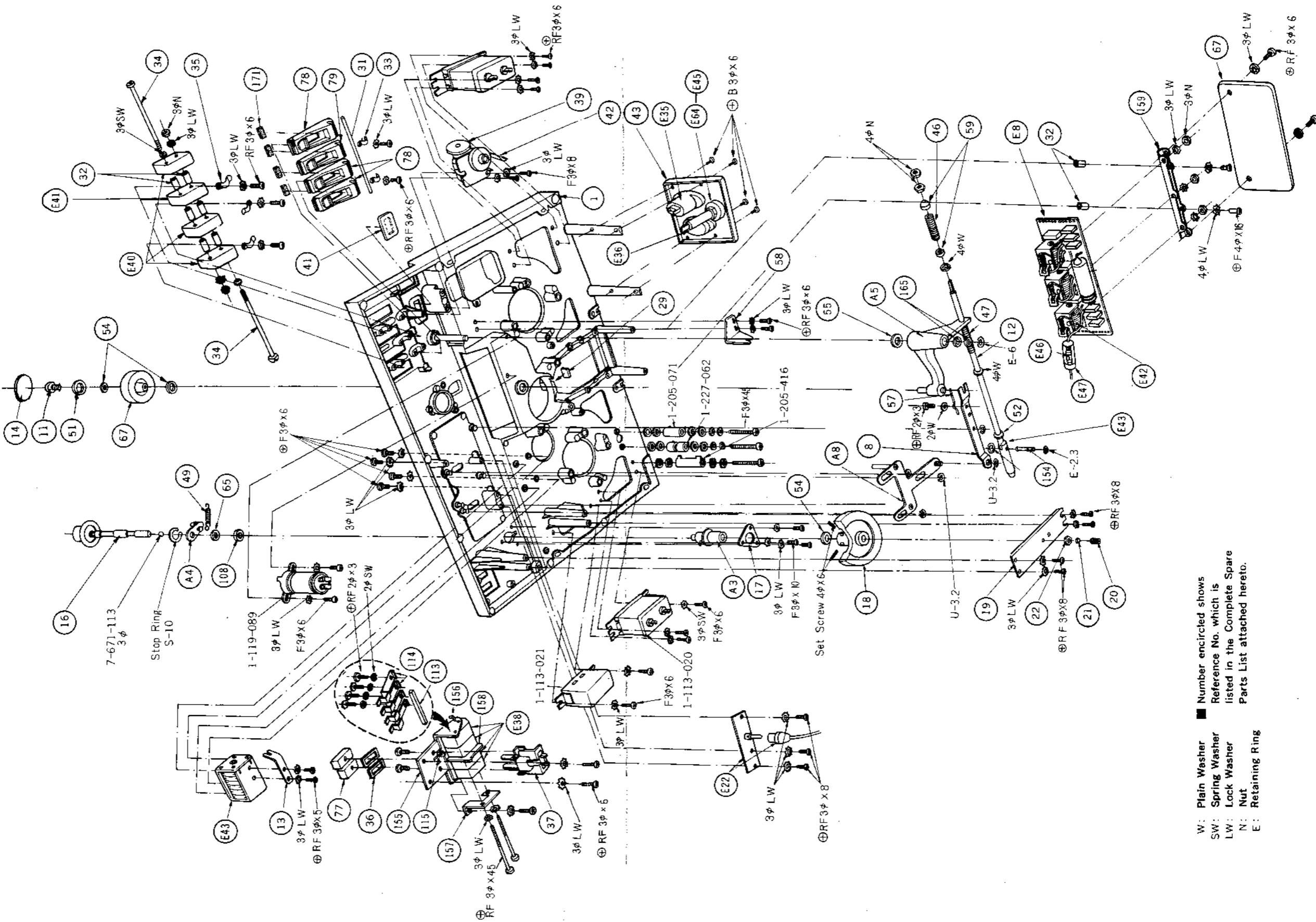

W: Plain Washer
SW: Spring Washer
LW: Lock Washer
N: Nut
E: Retaining Ring

■ Number encircled shows Reference No. which is listed in the Complete Spare Parts List attached hereto.

Exploded Diagram
Set—Top View

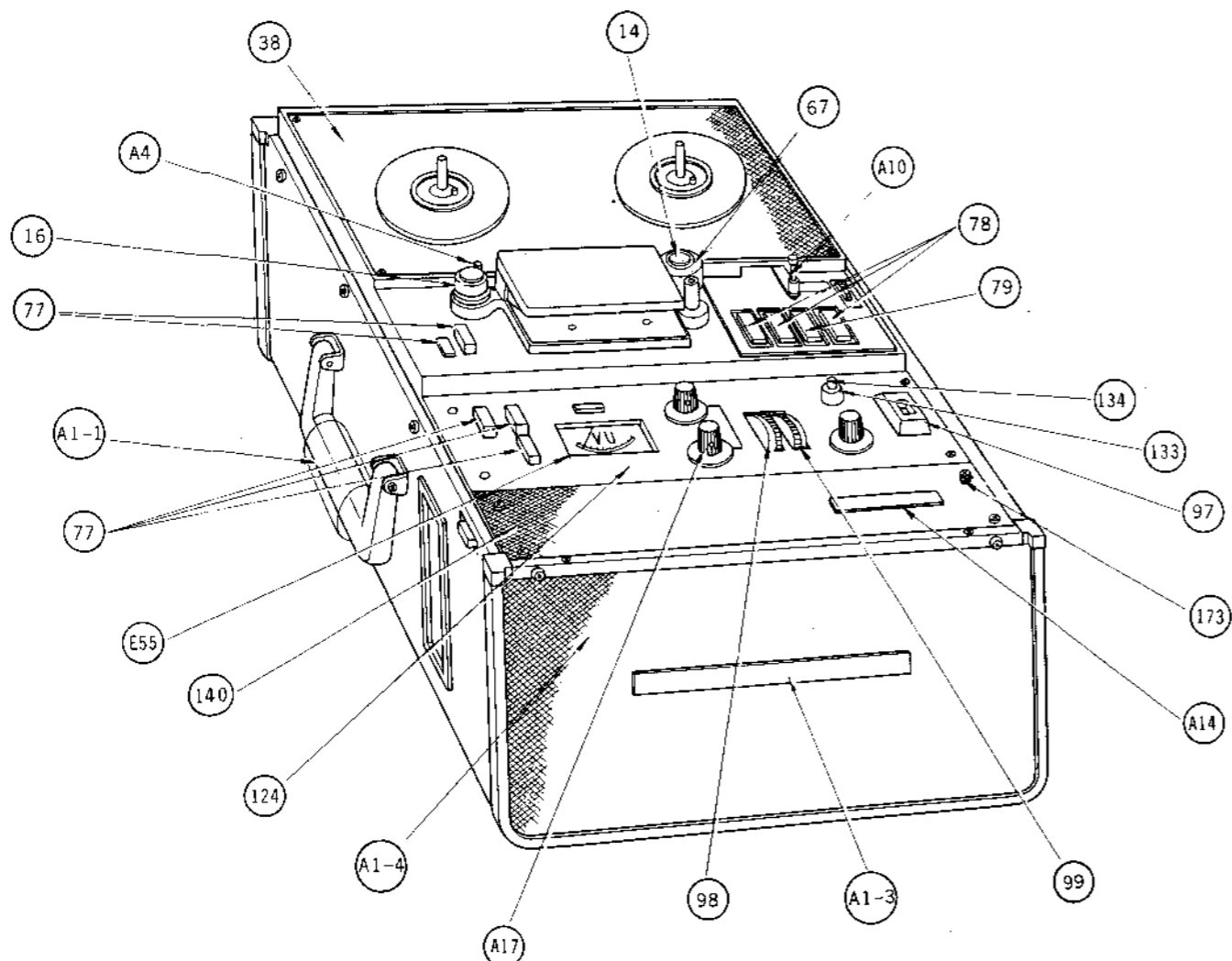

W: Plain Washer ■ Number encircled shows
 SW: Spring Washer Reference No. which is
 LW: Lock Washer listed in the Complete Spare
 N: Nut Parts List attached hereto.
 E: Retaining Ring

Exploded Diagram
Cabinet—Top View

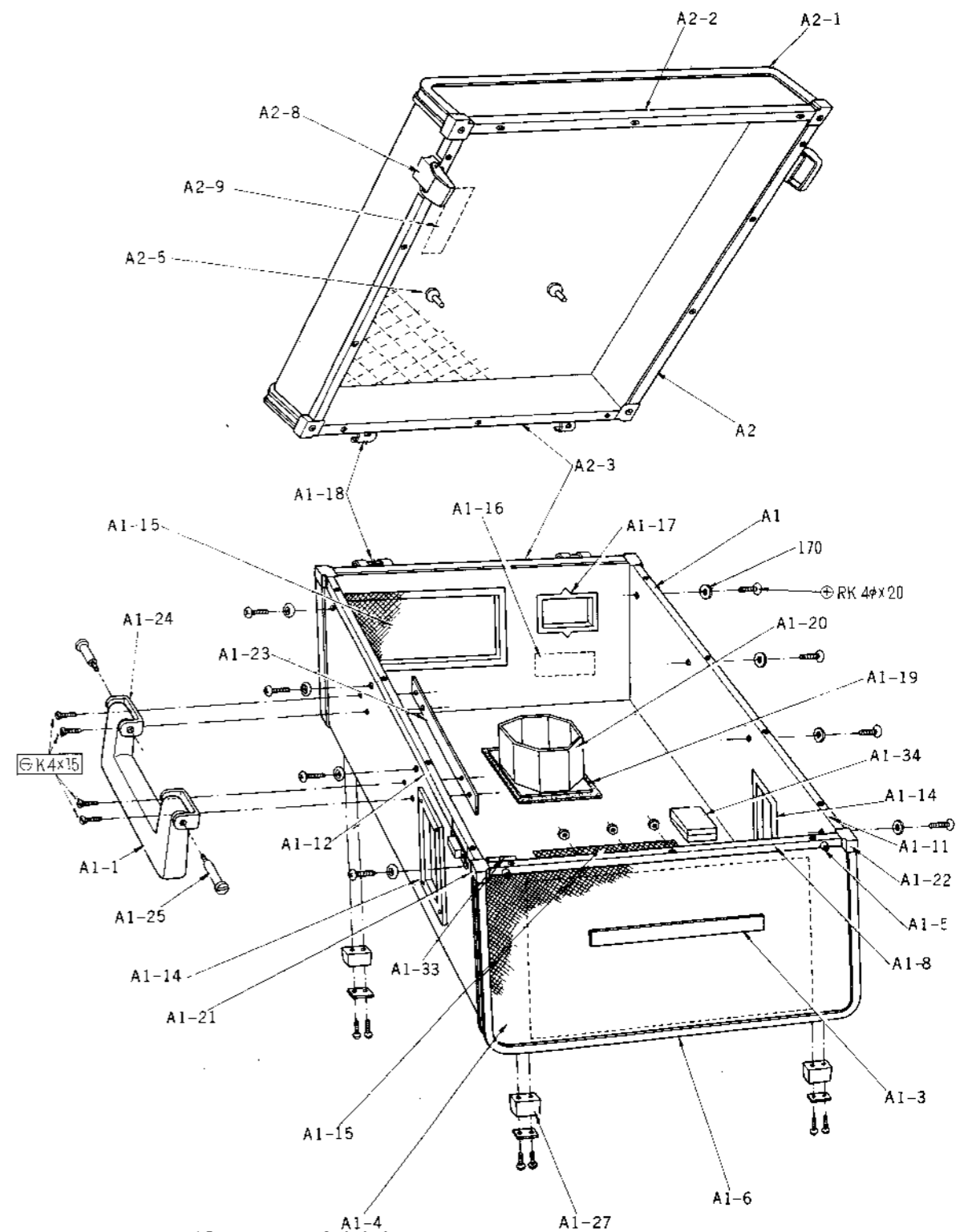

W: Plain Washer ■ Number encircled shows
 SW: Spring Washer Reference No. which is
 LW: Lock Washer listed in the Complete Spare
 N: Nut Parts List attached hereto.
 E: Retaining Ring

TC-777M TC-777M

Exploded Diagram

Front Chassis—Top View

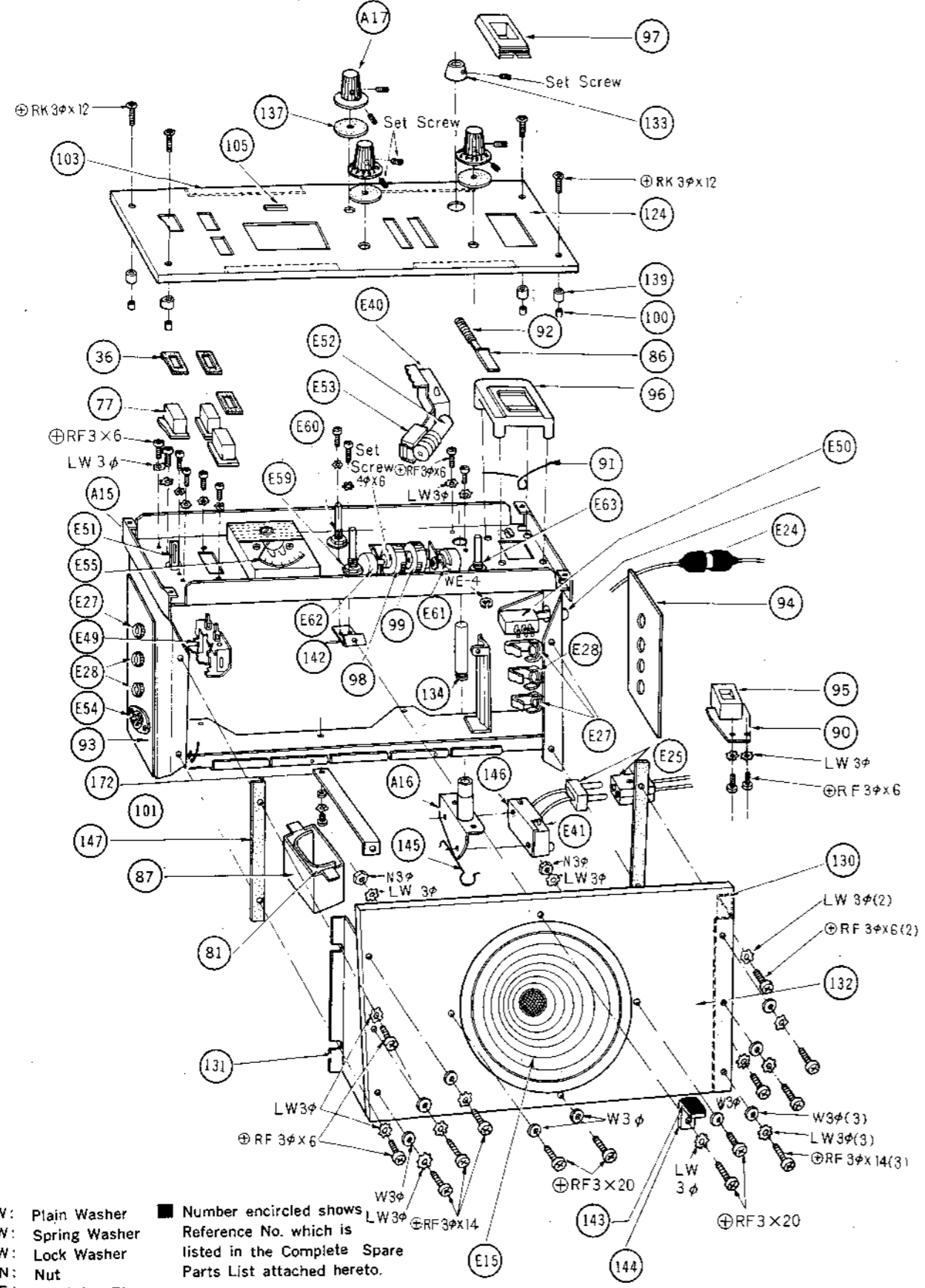

W: Plain Washer
 SW: Spring Washer
 LW: Lock Washer
 N: Nut
 E: Retaining Ring

■ Number encircled shows Reference No. which is listed in the Complete Spare Parts List attached hereto.

Exploded Diagram

Amplifier Chassis—Top View

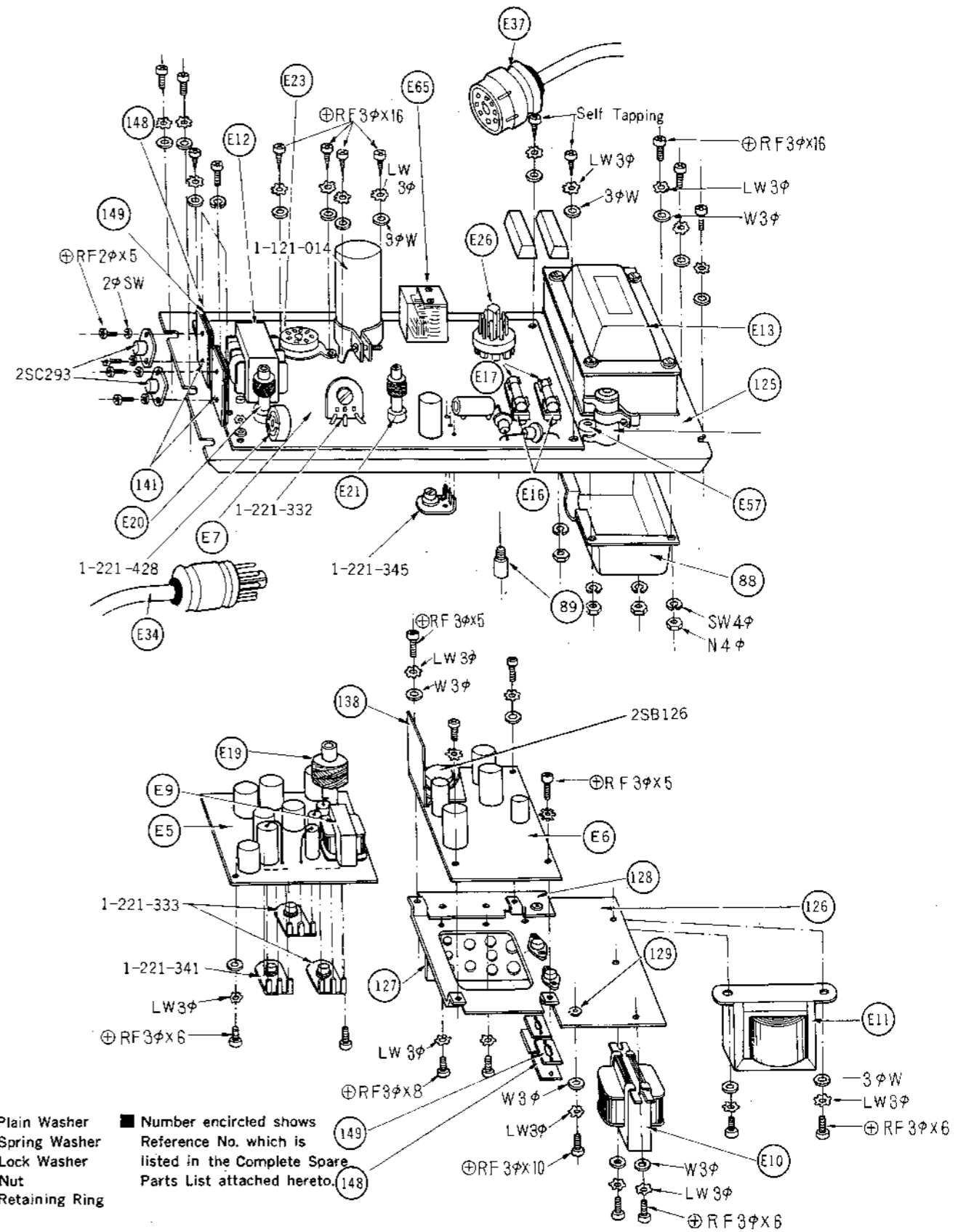

W: Plain Washer
 SW: Spring Washer
 LW: Lock Washer
 N: Nut
 E: Retaining Ring

■ Number encircled shows Reference No. which is listed in the Complete Spare Parts List attached hereto.

SONY CORPORATION

Complete Spare Parts List for TC-777M (E)

(w/Remote Controller)

<u>Ref. No.</u>	<u>Part No.</u>	<u>Description</u>
A1	X-31038-13-0	Cabinet Ass'y, bottom; including -----
A1-1	X-34039-08	Handle Grip Ass'y -----
-2	3-103-842	Cloth, dust protector -----
-3	-845	Badge, "PROFESSIONAL TAPECORDER 777M" ---
-4	-841-01	Speaker Board, front side -----
-5	-570	Foot, dark gray; small -----
-6	-836	Sash A -----
-7	-837	" B -----
-8	-838-01	" C -----
-9	-838-02	" C -----
-10	-839	" D -----
-11	-840-01	" E -----
-12	-840-02	" E -----
-13	-554	Catch, cabinet lid -----
-14	-562	Escutcheon, jack -----
-15	-559	Net, duct -----
-16	-853	Serial No. Plate -----
-17	-563	Escutcheon, power supply -----
-18	-555-05	Hinge -----
-19	-560	Ventilating Duct -----
-20	-561	Pipe, ventilating duct -----
-21	3-409-052-04	Bracket A, cabinet corner-fixing -----
-22	-053-04	" B, " " -----
-23	-116	Plate, handle grip holder -----
-24	0-051-247	Bracket, handle grip holder -----
-25	-248	Bolt, handle grip holder -----
-26	-249	Plate, handle grip holder -----
-27	3-107-613	Rubber Foot, square -----
-28	3-103-764-04	Lid, voltage selector -----
-29	-766	Shaft, voltage selector lid -----
-30	-765-01	Hinge, voltage selector lid -----
-31	0-041-317	Holder, voltage selector lid -----
-32	-319	Spring, voltage selector lid -----
-33	3-103-844-01	Cushion, cabinet small rubber -----
-34	-844-02	" " large " -----
A2	X-31038-11-1	Cabinet Lid Ass'y, including -----
A2-1	3-103-837	Sash B -----

<u>Ref. No.</u>	<u>Part No.</u>	<u>Description</u>
A2-2	3-103-838-02	Sash C -----
-3	-839	" D -----
-4	-553-03	Hinge -----
-5	-571	Shaft, reel holder -----
-6	-840-01	Sash E -----
-7	-840-02	" E -----
-8	-554	Catch -----
-9	-582	Badge "SONY" -----
-10	3-409-052-04	Bracket A, cabinet corner fixing -----
-11	-053-04	" B, " " " -----
A3	X-31030-12	Sleeve Ass'y, stabilizer -----
A4	-19	Arm Ass'y, stabilizer -----
A5	-21	Arm Ass'y, pinch roller -----
A6	-08	Brake Band Ass'y, take-up reel -----
A7	-09	" " " , feed reel -----
A8	-01-0	Shifter Arm Ass'y -----
A9	-02	Reel Table Ass'y, feed & take-up -----
A10	-11	Arm Ass'y, tension -----
A11	-33	Damper Ass'y, tension arm -----
A12	X-31039-05-3	Angle Ass'y, frame; right side -----
A13	-4	" " " ; left side -----
A14	X-31038-12	Badge Ass'y, "SONY" -----
A15	X-31039-06	Chassis Ass'y, amplifier -----
A16	-07	Boss Ass'y, instant stop switch -----
A17	-17	Knob Ass'y, volume control -----
1	3-103-001	Main Chassis -----
2	-004	Head Cover -----
3	-006	Pin, head cover holder -----
4	-007	Epron, head -----
5	-008	Shield Plate A, head -----
6	-010	Plate, head mounting -----
7	-011	Shield Case, playback head -----
8	-018	Arm, shifter jointing -----
9	-022	Holder, capstan shaft -----
10	-025	Flywheel, capstan shaft -----
11	-033	Screw, pinch roller holder -----
12	-035	Joint Rod, solenoid -----
13	-036	Bracket, solenoid -----
14	-039	Cap, pinch roller -----
15	-042	Lug, 3/4 tension arm spring hunger -----
16	-046	Shaft, stabilizer -----
17	-051	Metal Holder, stabilizer -----

<u>Ref. No.</u>	<u>Part No.</u>	<u>Description</u>
18	3-103-052	Flywheel, stabilizer -----
19	-053	Retainer, " -----
20	-054	Screw, thrust adjustable -----
21	-055	Fiber, thrust retainer -----
22	-056	Nut, adjustable -----
23	-058	Pin, shifter -----
24	-059	Screw, reel table holder; 4 x 8 -----
25	-063	Brake Arm A -----
26	-064	" " B -----
27	-066	Lug, spring hunger; brake -----
28	-067	Angle, solenoid holder -----
29	-069	Damper, solenoid; rubber -----
30	-071	Cushion, control button -----
31	-072	Shaft, control button -----
32	-073	Spacer, control button; sleeve -----
33	-074	Plate, control button shaft holder -----
34	-075	Shaft, button holder; control -----
35	-076	Plate, switch holder -----
36	-078	Cushion, control knob -----
37	-079	Switch, speed selector -----
38	-082-04	Reel Panel -----
39	-087-02	Counter, M311 -----
40	-088	Knob, tape counter -----
41	-089	Lens, " " -----
42	-090	Belt, " " -----
43	-095	Plate, connector holder -----
44	-103	Belt, capstan, wide -----
45	-105	Pin, bearing metal -----
46	-106	Spring, pressure; shifter -----
47	-107	Spring, reset -----
48	-108	Brake Spring -----
49	-110	Spring, stabilizer -----
50	-111	Spring, tension arm -----
51	-112	Felt, capstan shaft -----
52	-114	Felt, 5ø; pinch roller solenoid rod -----
53	-116	Washer, 5ø fiber -----
54	-117	Washer, 6ø fiber -----
55	-118	Washer, 7ø fiber -----
56	-120	Ring, metal holder -----
57	-126	Spring, shifter arm -----
58	-127	Bracket, reset spring holder -----
59	-134	Spacer, pressure spring -----

<u>Ref.</u> <u>No.</u>	<u>Part No.</u>	<u>Description</u>
60	3-103-143	Cover, capacitor; fiber -----
61	-214	Holder, bearer -----
62	-266	Ring, bearer -----
63	-267	Washer, 16 ϕ ; bearer -----
64	-274	Washer, 8 ϕ ; flywheel -----
65	-215	Washer, 10 ϕ ; stabilizer -----
66	-295	Washer, 10 ϕ ; stabilizer; nylon -----
67	-262	Pinch Roller -----
68	-254	Bracket, solenoid holder -----
69	-238	Spring, tape guide adjustable -----
70	-239	Shaft, tape guide -----
71	-240	Tape Guide C -----
72	-241	Tape Guide D -----
73	-226	Boss, tension arm -----
74	-227	Plate, micro switch adjustable -----
75	-297	Shaft, tension arm -----
76	-298	Damper, tension arm -----
77	-255-02	Button, control; dark gray -----
78	-259-04	Button, control; ivory -----
79	-05	Button, control; dark gray -----
80	-207	Bracket, frame reinforcement -----
81	-286	Insulator, switch; fiber -----
82	-502	Bracket, micro switch holder -----
83	-504-01	Arm, chassis holder -----
84	-02	Arm, chassis holder -----
85	-505	Bracket, chassis holder -----
86	-506	Bracket, record button holder -----
87	-508	Cover, power switch -----
88	-509	Cover, power transformer -----
89	-514	Rod, connector holder -----
90	-516	Plate Spring, record button -----
91	-517	Spring, record button -----
92	-518	Spring, record button lock -----
93	-519	Ornamental Plate, input jack -----
94	-520	Ornamental Plate, output jack -----
95	-521	Button Record, -----
96	-522	Guard, record button; lower -----
97	-523	Guard, record button; upper -----
98	-524-03	Knob, tone control; bass -----
99	-04	Knob, tone control; treble -----
100	-526	Sleeve, control panel stopper -----
101	-527	Binder, wire holder -----

<u>Ref. No.</u>	<u>Part No.</u>	<u>Description</u>
102	3-103-530	Bracket, OSC trans holder -----
103	-531	Cushion, control panel -----
104	-532	Insulator, switch; fiber -----
105	-525-02	Lens, pilot lamp -----
106	-963	Ring, capstan shaft holder -----
107	-964-00	Washer 4ø, capstan shaft holder -----
108	-966	Washer 12ø, stabilizer holder -----
109	-970	Screw 4 x 7, solenoid holder -----
110	-971	Spacer 3.8ø, solenoid holder; cushion -----
111	-961	Screw 3 x 5, -----
112	-965	Washer 3ø, head mounting plate -----
113	-949	Cushion, micro switch -----
114	-959	Spring, control knob; plate -----
115	-960	Bracket, switch holder -----
116	-956	Wire Retainer -----
117	-914	Angle, main chassis holder -----
118	-921-02	Angle, frame holder -----
119	-03	Angle, frame holder -----
120	-922-02	Bracket, panel holder -----
121	-03	Bracket, panel holder -----
122	-901-05	Chassis, amplifier -----
123	-902	Bracket, chassis reinforcement -----
124	-903	Control Panel -----
125	-904	Chassis, power supply -----
126	-905	Chassis, power amplifier -----
127	-906	Heat Sink, transistor 2SC293 -----
128	-907	Insulator, power amplifier; fiber -----
129	-908	Bushing, chassis holder; fiber -----
130	-909	Bracket C, speaker holder -----
131	-910	Bracket D, speaker holder -----
132	-911	Baffle Board, speaker -----
133	-912	Guard, instant stop button -----
134	-913	Rod, instant stop button -----
135	-917	Knob, volume control -----
136	-918-02	Indicating Sheet, volume knob -----
137	-919	Cushion, volume knob; felt -----
138	-924	Heat Sink, transistor 2SB26 -----
139	-925	Rod, control panel -----
140	-931	Panel, speaker -----
141	-920	Heat Sink, transistor 2SC292 -----
142	-942	Bracket, baffle board holder -----
143	-943	Rubber Seat, baffle board holder -----

Ref. No.	Part No.	Description
144	3-103-944	Bracket, baffle board holder -----
145	-953	Spring, instant stop button -----
146	-954	Bracket, switch holder -----
147	-955	Cushion, speaker board -----
148	-957	Printed Circuit Board, transistor 2SC293 ---
149	-958	Insulator, transistor 2SC293 -----
150	-997	Spacer, monitor switch holder -----
151	3-404-214-01	Motor Pulley 50 Hz -----
152	-02	Motor Pulley 60 Hz -----
153	-216	Cap, capstan shaft -----
154	-228	Pin, solenoid -----
155	-205	Bracket, control switch holder -----
156	-207	Rod, switch operation adjustable -----
157	-208	Bracket, switch holder -----
158	-263	Shield Plate, micro switch -----
159	-261	Angle, relay holder -----
160	-262	Insulator, relay; fiber -----
161	3-123-010-01	Capstan Shaft -----
162	-011	Washer, stabilizer wheel; adjustable -----
163	3-005-001-60	Screw, record head holder -----
164	-001-70	Spring, record head -----
165	0-027-058	Washer, pinch roller arm adjustable -----
166	0-041-029	Washer, reel panel -----
167	-223	Spacer, jack -----
168	3-401-179	Wire Retainer -----
169	3-107-086	Speed Nut -----
170	3-103-206	Ornamental Washer, cabinet 15 ϕ -----
171	3-103-946	Cushion, control knob -----
172	-948	Bracket, baffle board holder -----
173	-947	Washer, panel 3 ϕ -----
174	-941	Tape Guide -----

Screws

7-621-255-02	(+) RF 2 x 3 -----
-32	(+) RF 2 x 5 -----
-259-22	(+) RF 2.6 x 4 -----
-45	(+) RF 2.6 x 6 -----
-260-02	(+) RF 2.6 x 16 -----
-261-25	(+) RF 3 x 4 -----
-35	(+) RF 3 x 5 -----
-45	(+) RF 3 x 6 -----

Ref.
No.

Part No.

Description

7-621-261-42	(+) RF 3 x 6 -----
-55	(+) RF 3 x 8 -----
-65	(+) RF 3 x 10 -----
-85	(+) RF 3 x 14 -----
-82	(+) RF 3 x 14 -----
-92	(+) RF 3 x 15 -----
-262-05	(+) RF 3 x 16 -----
-02	(+) RF 3 x 16 -----
-25	(+) RF 3 x 20 -----
-92	(+) RF 3 x 45 -----
-268-45	(+) RF 4 x 6 -----
-55	(+) RF 4 x 8 -----
-65	(+) RF 4 x 10 -----
-75	(+) RF 4 x 12 -----
-269-05	(+) RF 4 x 16 -----
-35	(+) RF 4 x 22 -----
-722-91	(+) RF 3 x 16 (Self Tapping) -----
-715-34	4 x 6 w/6" Square Hole (Self Tapping) -----
-17	4 x 4 (Self Tapping) -----
-718-38	4 x 6 (" ") -----
-555-42	(+) K 2 x 6 -----
-45	(+) K 2 x 6 -----
-561-42	(+) K 3 x 6 -----
-655-46	(+) RK 2 x 6 -----
-661-76	(+) RK 3 x 12 -----
-699-12	(+) RK 4 x 18 -----
-770-36	(+) B 3 x 12 -----
-28	(+) B 3 x 6 -----
-26	(+) B 3 x 6 -----

Nuts

7-622-105-02	2 ϕ -----
-107-02	2.6 ϕ -----
-108-02	3 ϕ -----
-110-02	4 ϕ -----

Washers

7-623-205-22	Spring 2 ϕ -----
-207-25	" 2.6 ϕ -----
-208-22	" 3 ϕ -----

<u>Ref. No.</u>	<u>Part No.</u>	<u>Description</u>
	7-623-210-12	Spring 4 ϕ -----
	-113-12	6 ϕ -----
	-108-12	3 ϕ -----
	-407-01	Lock 2.6 ϕ (outer) -----
	-408-05	" 3 ϕ (") -----
	-308-05	" 3 ϕ (inner) -----

Eyelet

	7-623-604-01	1.7 x 3 -----
	-616-01	2 x 3 -----
	-616-21	2 x 3 w/lug -----

Retaining Ring

	7-624-108-01	E-4 -----
	-110-05	E-6 -----
	-108-05	E-4 -----
	-105-05	E-2.3 -----
	-147-05	U-3.2 -----

Rivet

	7-625-114-21	R3 x 4 -----
--	--------------	--------------

Nail

	7-629-100-13	1 x 6 -----
	7-671-113-01	Steel Ball, 3 ϕ -----
	7-624-181-01	Snap Ring S-10 -----

Accessories

	1-534-063	Connection Cord, RK-55 -----
	81-1810-21	Microphone, F-81 (LQ) -----
	85-2171-00	Blank Tape, S-7 -----
	86-0071-00	Reel R-7A -----
	86-5001-00	Splicing Tape -----
	3-103-544	Bag, accessories -----

<u>Ref. No.</u>	<u>Part No.</u>	<u>Description</u>
	3-103-083	Reel Cap -----
	Y-20161-01	SONY Oil, OL-1K -----
	92-2404-00	Tool Set -----
	3-103-978-01	Sheet, tension arm -----
		Remote Control Set, model RM-8 -----
	1-534-031-02	Rec./P.B. Connector, RC-2 -----
	-142-11	AC Power Cord, special -----
	3-793-009-11	Inspection Card -----
	-010-20	Tape Talk -----
	7-491-001	Desiccant -----
	3-404-214-01	Motor Pulley, -01; 50 Hz -----
	(-02)	" " , -02; 60 Hz -----
	3-103-979-10	Instruction Manual (S1-P-0255-1) -----
		Wrench, L type 4ø -----
	3-103-938	Bag, polyethylene; packing -----
	3-103-592-05	Carton, accessory bag -----
	-952-04	" , microphone -----
	-940-04	" , microphone & remote control -----
	-939-17	" , outer -----
	-18	" , inner -----
	-19	Cushion, carton corner -----
	-20	Separator, carton -----
	-21	Cushion, upper & lower -----
	-22	Protecting Cover, carton -----
	X-37010-06-2	Tack Label Ass'y, 60 Hz -----
	-07-2	" " " , 50 Hz -----

Electrical Parts

E1	X-31039-11-3	Mounted Circuit Board, pre-amplifier -----
E2	-12-4	" " " , power amplifier -----
E3	-13-6	" " " , power supply & bias OSC -----
E4	-14-0	" " " , relay -----
E5	3-103-926-02	Printed Circuit Board, pre-amplifier -----
E6	-927-02	" " " , power amplifier -----
E7	-928-06	" " " , power supply & bias OSC -----
E8	3-404-274-01	" " " , relay -----

Ref.
No.

Part No.

Description

Transistor

2SB381	X3,4,8,9,10,11,12,13 -----
2SB382	X1,2,6,7; low noise -----
2SB382	X5 -----
2SB126	X17 -----
2SC292	X18,19 -----
2SC293	X14,15,16 -----

Diode

1S358 (1S204)	V100 -----
S2A-10	D200,201 -----
1S123	D301 -----

Transformer

E9	1-427-075	Line Out, 1K : 600	T100 -----
E10	1-423-052	Input	T101 -----
E11	1-427-074	Output, 100 : 8	T102 -----
E12	1-433-027	Bias OSC	T200 -----
E13	1-441-072	Power	PT200 -----
E14	1-509-056	Socket, voltage selector	-----
E15	1-502-078	Speaker; 160mm, 8 ohms	SP100 -----
E16	1-533-006	Fuse Holder w/ Cover	FB200,201 -----
E17	1-532-006	Fuse, 1A	F200 -----
E18	1-532-007	" , 1.5A	F201 -----
E19	1-409-128	Trap Coil, 4mH	L100 -----
E20	1-409-129	" " , 1.4mH	L200 -----
E21	1-431-044	Equalizer Coil, 0.3-0.84mH	L201 -----
E22	1-509-052	Connector, 2P CN300P, 300S/set	-----
E23	-051	" , 8P CN302S	-----
E24	-050	" , 2P RCA type CN306PS	-----
E25	-014	" , plain type, CN303P, 303S/set	----
E26	-039	Plug, 8P CN301P	-----
E27	1-507-107	Jack, D type; J102,103,104	-----
E28	-108	Jack, E type; J100,101,102	-----
E29	83-1634-04	Motor, HC-634D4; capstan	M301 -----
E30	83-2524-03	Motor, IC-524R1; reel	M302,303 -----
E31	82-0704-01	Head, playback; PP15-04L	-----
E32	82-3623-00	Head, record; RP15-03	-----

<u>Ref. No.</u>	<u>Part No.</u>	<u>Description</u>
E33	82-6303-00	Head, erase, EF-3 -----
E34	1-509-053	Connector, 8P CN302P -----
E35	-013	" , power CN304S -----
E36	-031	Socket 8P (remote) CN305S -----
E37	-035	" 8P CN301S -----
E38	1-514-057	Micro Switch, WV15-1A speed selector S301-1 - 4 -----
E39	-110-12	" " , V-1A446-1 safety S302 -----
E40	-059	" " , WV15-3A rec. button S303,305, 306,201 -
E41	-058	" " , WV15-2A instant stop S304,202-
E42	1-515-099	Relay, MK-3 RLY301,302,303 -----
E43	1-454-002	Solenoid, PSL-2; pinch roller, PM302 -----
E44	-003	" , BSL-2; brake PM301 -----
E45	1-532-008	Fuse, 2A F301 -----
E46	-013	" , 0.8A F302 -----
E47	1-533-007	Fuse Post FB302 -----
E48	-048	" " FB301 -----
E49	1-513-165	Switch, monitor S100 -----
E50	-149	" , speaker S101 -----
E51	1-514-140-12	" , power ON/OFF S200 -----
E52	1-518-011	Pilot Lamp, 8V PL200 -----
E53	1-517-003	Socket, pilot lamp PLB-200 -----
E54	1-509-029	" , rec./p.b. connector CN307S -----
E55	1-520-042-11	Meter, level M -----
E56	1-536-005	Lug, 1-1P Lug1 -----
E57	1-599-003	Bushing, rubber 10# -----
E58	0-007-313	Wire Retainer -----
E64	1-533-012	Fuse Post FB301 -----
E65	1-515-003	Relay RLY200 -----

Potentiometer

E59	1-221-294	10K MIC vol. VR100 -----
E60	-280	100K Line vol. VR101 -----
E61	-284	55K Tone treble VR102 -----
E62	-287	20K Tone bass VR103 -----
E63	-285	10K SP vol. VR104 -----

Resistor, adjustable

1-221-333	10K	R119,142 -----
-----------	-----	----------------

Ref.
No.

Part No.

Description

1-221-341	20K		R132 -----
-324	50K		R171 -----
-332	300		R208 -----
-345	4K		R221 -----
-428	10K	(carbon)	R213 -----

Resistor, solid

1-202-429	82K	RC $\frac{1}{2}$ GF	R100,103 -----
-417	27K	"	R217 -----
-413	18K	"	R145 -----
-397	3.9K	"	R169 -----
-409	12K	"	R133,137,140 -----
-405	8.2K	"	R101,102,110,125,204, 150,224 -----
-404	7.5K	"	R146 -----
-403	6.8K	"	R120,156 -----
-399	4.7K	"	R117,225 -----
-398	4.3K	"	R114,115,118,141 -----
-395	3.3K	"	R121,134,143 -----
-391	2.2K	"	R154,148,149 -----
-387	1.5K	"	R136,162,153 -----
-385	1.2K	"	R155,222 -----
-383	1K	"	R122,160 -----
-381	820	"	R123,165,167 -----
-377	560	"	R138,159,161 -----
-375	470	"	R139,147 -----
-365	180	"	R124 -----
-371	330	"	R151 -----
-373	390	"	R152 -----
-389	1.8K	"	R223 -----
-393	2.7K	"	R108,157 -----
-408	18K	"	R107 -----
-435	150K	"	R113 -----
-443	330	"	R135 -----
-369	270	"	R164 -----
-361	120	"	R116,170 -----
-355	68	"	R128 -----
-341	47	"	R168,109,206,207 -----
-337	33	"	R158 -----
-577	1.5K	"	R201 -----
-549	100	"	R209 -----

<u>Ref. No.</u>	<u>Part No.</u>	<u>Description</u>	
	1-202-533	22 RC $\frac{1}{2}$ GF	R163 -----
	-567	560 "	R166 -----
	1-201-296	120 RC $\frac{1}{2}$ L	R304 -----
	-244	6.8K "	R301 -----

Resistor, carbon

	1-242-687	3.9K RD $\frac{1}{2}$ UR	R131 -----
	-689	4.7K "	R130 -----
	-693	6.8K "	R127 -----
	-694	7.5K "	R129 -----
	-699	12K "	R106 -----
	-705	22K " (Noiseless)	R104,105,111,126 --
	-697	10K " (")	R112 -----
	1-203-613	1 RD $\frac{1}{2}$ L	R211,212 -----
		1K RD1SP	R210 -----
		1 "	R200 -----
		2K RD2SP	R202 -----
		300 "	R203 -----

Resistor, wire wound

	1-205-062	30	R214 -----
	-416	5K	R305 -----
	-071	50	R302 -----
	1-227-071	30 adjustable	R303 -----
	-002	80 "	R205 -----

Capacitor, polyethylene

	1-129-184	0.001uF 125WV	C207 -----
	-217	0.024uF "	C203,204 -----
	-219	0.03uF "	C209 -----
	-205	0.0075uF 250WV	C208 -----
	-118	300PF 50WV	C143 -----
	-128	750PF "	C113,139 -----

Capacitor, mylar

	1-105-827	0.0033uF 50WV	C118 -----
	-673	0.01uF 100WV	C105 -----

<u>Ref. No.</u>	<u>Part No.</u>	<u>Description</u>		
1-105-861		0.001uF	100WV	C100 -----
-677		0.022uF	50WV	C215 -----
-679		0.033uF	"	C216 -----
-841		0.047uF	"	C128,129 -----
-685		0.1uF	"	C210,211 -----
-845		0.1uF	"	C130,131 -----
-731		0.33uF	100WV	C213 -----
-689		0.22uF	50WV	C212 -----
-821		0.001uF	"	C142 -----
-721		0.047uF	100WV	C205 -----
-963		0.068uF	400WV	C305,306,307 -----

Capacitor, metalized paper

1-113-020	4uF	250V	C310,311 -----
-021	2+0.5uF	"	C309 -----
-109	0.1uF	"	C301,302,303,304,308, 314,315,316,317,318, 319,320,202 -----
1-117-005	0.1uF	"	C214 -----

Capacitor, electrolytic

1-119-009	30uF	6WV	C103 -----
-020	100uF	15WV	C108,111,122,124,140 ---
-096	10uF	25WV	C123 -----
-089	100uF	150WV	C312 -----
-091	10uF	15WV	C101,104,107,109,115, 110,112,121,116 -----
1-121-358	200	15WV	C102,106,117,114,132, 141 -----
-081	500uF	15WV	C119,136,137,138 -----
-360	10uF	15WV	C120,125,126,127 -----
-291	100uF	6WV	C133,134 -----
-349	30uF	10WV	C135 -----
-014	2000uF	25WV w/ Lug	35p C200 -----
-297	200uF	25WV	C206 -----

Additional Spare Parts for TC-777M (E)

3-103-071	Damper, control knob; rubber -----
-----------	------------------------------------

<u>Ref. No.</u>	<u>Part No.</u>	<u>Description</u>
	3-103-073	Spacer, control knob; sleeve -----
	-074	Bracket, control knob shaft holder -----
	-151	Top Panel -----
	-152	Case, bottom side -----
	-153	Badge, SONY -----
	-154-01	Control Direction Mark; REW & F.F. -----
	-154-02	" " " ; STOP -----
	-154-03	" " " ; FWD -----
	-157	Wire Retainer, cabtyre cord -----
	-158	Base, micro switch holder -----
	-159	Shaft, micro switch holder -----
	-160	Shaft, control knob -----
	-161	Spacer, micro switch sleeve -----
	-162	Stopper Plate, lock bar -----
	-163	Lock Bar -----
	-164	Knob, record lock -----
	-165	Spring, record lock -----
	-166	Guide Plate, record lock -----
	-191	Bag, polyethylene -----
	-196-01	Cushion, record button; rubber -----
	-196-02	" , F.F., REW, STOP, FWD; button -----
	-259-04	Button, REW, F.F., FWD -----
	-259-05	" , STOP -----
	-259-06	" , record -----
	-323	Mark, record button -----
	-570	Foot, dark gray -----
	-193-04	Carton -----
	0-110-554-01	Bushing, cabtyre cord -----

Screw

7-621-261-45	(+) RF 3 x 6 -----
-255-45	(+) RF 2 x 6 -----
-561-45	(+) K 3 x 6 -----
-561-75	(+) K 3 x 12 -----

Nut

7-622-108-02	3 ϕ -----
--------------	----------------

Lock Washer

7-623-405-05	2 ϕ (outer) -----
--------------	------------------------

<u>Ref. No.</u>	<u>Part No.</u>	<u>Description</u>
	7-623-408-05	3 ϕ (outer) -----
	-308-05	3 ϕ (inner) -----
		<u>Retaining Ring</u>
	7-624-103-01	E-1.9 -----
	1-514-057	Micro Switch, VV15-1A -----
	1-534-075-13	Cable Cord -----