

SONY-00920

# TC-755A

*AEP Model*

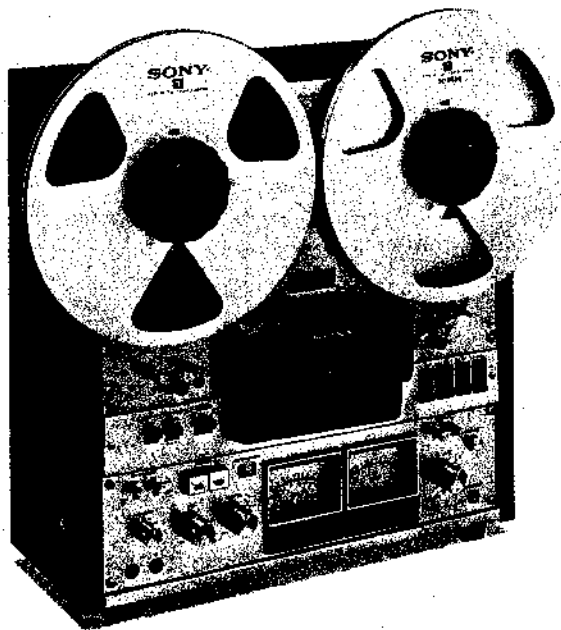

## STEREO TAPECORDER

### SPECIFICATIONS

**Power Requirements:** AC 110, 127, 220, or 240 V, 50/60 Hz

**Power Consumption:** 110W

**Track System:** Four-track two-channel stereo and monaural

**Reels:** 270 mm (10½ inches) or smaller

**Tape Speed:** 19 cm/s (7½ ips), 9.5 cm/s (3¾ ips)

**Recording Time:** 6 hours total at 9.5 cm/s (3¾ ips), stereo recording, with 1,100 m (3360 ft.) tape of 270 mm (10½ inch) reel

**Frequency Response:** With Sony Ferri-Chrome Tape  
30–27,000 Hz at 19 cm/s (7½ ips)  
30–18,000 Hz at 9.5 cm/s (3¾ ips)  
With SLH tape  
30–25,000 Hz at 19 cm/s (7½ ips)  
30–16,000 Hz at 9.5 cm/s (3¾ ips)  
With Regular Tape  
30–20,000 Hz at 19 cm/s (7½ ips)  
30–13,000 Hz at 9.5 cm/s (3¾ ips)

**Signal-to-Noise Ratio:** 58 dB with Sony Ferri-Chrome Tape

**Wow and Flutter:** ±0.07% at 19 cm/s (7½ ips)  
±0.10% at 9.5 cm/s (3¾ ips)

**Record Bias Frequency:** Approximately 160 kHz

**Equalization:** NAB standard

**Total Harmonic Distortion:** 0.8%

**Fast Winding Time:** 2 min. 30 sec. with 740 m tape (10½ inch reel)

**Inputs:** MIC (2)  
Impedance: low  
Maximum sensitivity: -72 dB (0.2 mV)  
LINE IN (2)  
Impedance: 100 kΩ  
Maximum sensitivity: -22 dB (60 mV)

**Outputs:** LINE OUT (2)  
Impedance: 10 kΩ or more

With 100 kΩ load  
Level PB LEVEL control

-5 dB (0.44 V) detent position  
0 dB (0.775 V) MAX

HEADPHONES  
Impedance: 8 Ω

**REC/PB (DIN) Connector:** Input impedance: Less than 10k Ω  
Output impedance: Less than 10k Ω

**Dimensions:** 435 (w) x 451 (h) x 221 (d) mm  
17½ (w) x 17¾ (h) x 8¾ (d) inches

**Weight:** 24 kg, 52 lb 15 oz

# SONY®

## SERVICE MANUAL

**TABLE OF CONTENTS**

<u>Section</u>	<u>Title</u>	<u>Page</u>
	Specifications .....	1
<b>1.</b>	<b>OUTLINE</b>	
	1-1. Block Diagrams .....	3
	1-2. External View .....	4
	1-3. Internal View (1) .....	4
	1-4. Internal View (2) .....	5
	1-5. Internal View (3) .....	5
	1-6. Internal View (4) .....	5
	1-7. Notes on Operation .....	6
	1-8. Notes on Repair .....	7
<b>2.</b>	<b>ADJUSTMENTS</b>	
	2-1. Mechanical Adjustments .....	8
	2-2. Electrical Adjustments .....	16
<b>3.</b>	<b>DIAGRAMS</b>	
	3-1. Schematic Diagram – Amp Section – .....	27
	3-2. Mounting Diagram – Amp Section – .....	29
	3-3. Mounting Diagram – System Control Section – .....	32
	3-4. Schematic Diagram – System Control Section – .....	35
<b>4.</b>	<b>EXPLODED VIEWS AND PACKING</b>	
	4-1. Exploded View (1) .....	37
	4-2. Exploded View (2) .....	39
	4-3. Exploded View (3) .....	41
	4-4. Exploded View (4) .....	43
	4-5. Exploded View (5) .....	45
	4-6. Exploded View (6) .....	46
	4-7. Exploded View (7) .....	47
	4-8. Exploded View (8) .....	49
	4-9. Exploded View (9) .....	51
	4-10. Exploded View (10) .....	53
<b>5.</b>	<b>ELECTRICAL PARTS LIST</b> .....	55

*When ordering replacement parts, use PART NUMBERS listed in Parts Lists or shown in EXPLODED VIEWS. Do not use reference numbers shown in exploded views.*

SECTION 1  
DIAGRAMS

1-1. BLOCK DIAGRAMS

Amp Section

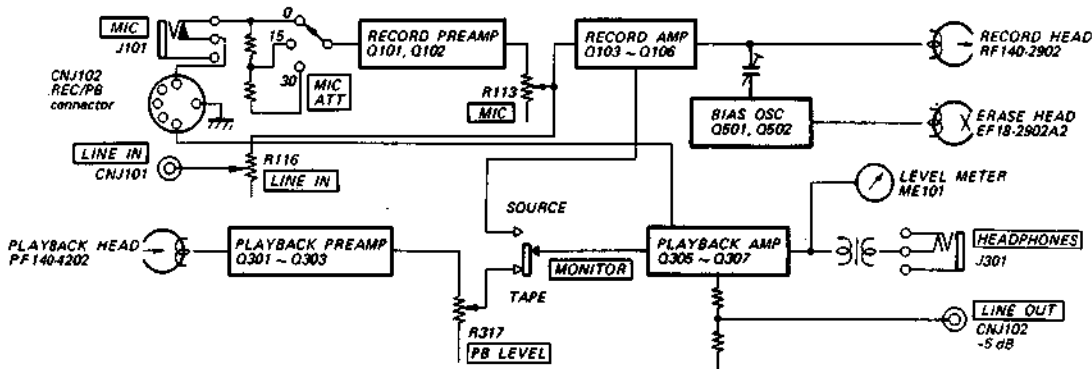

System Control Section

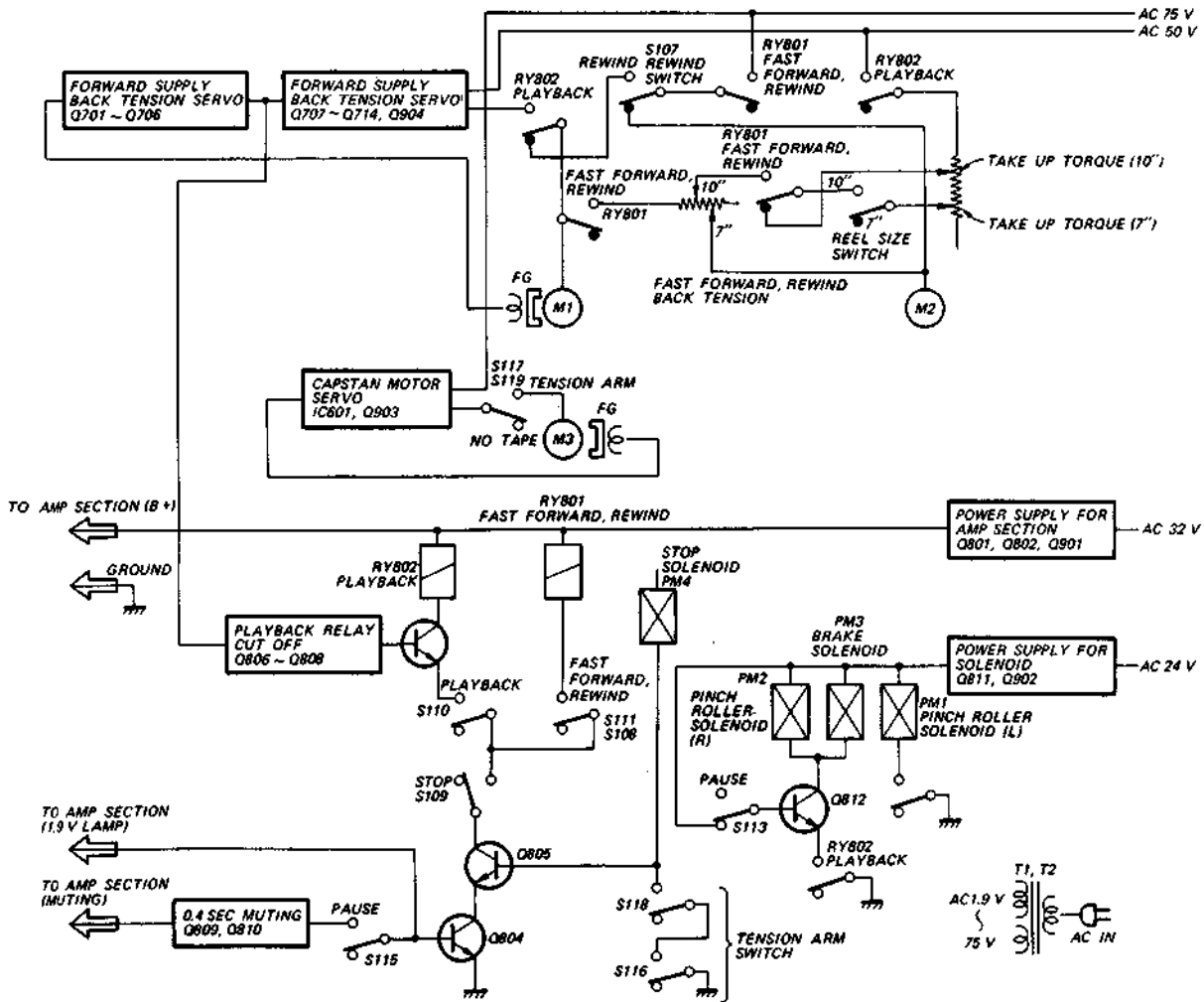

## 1-2. EXTERNAL VIEW

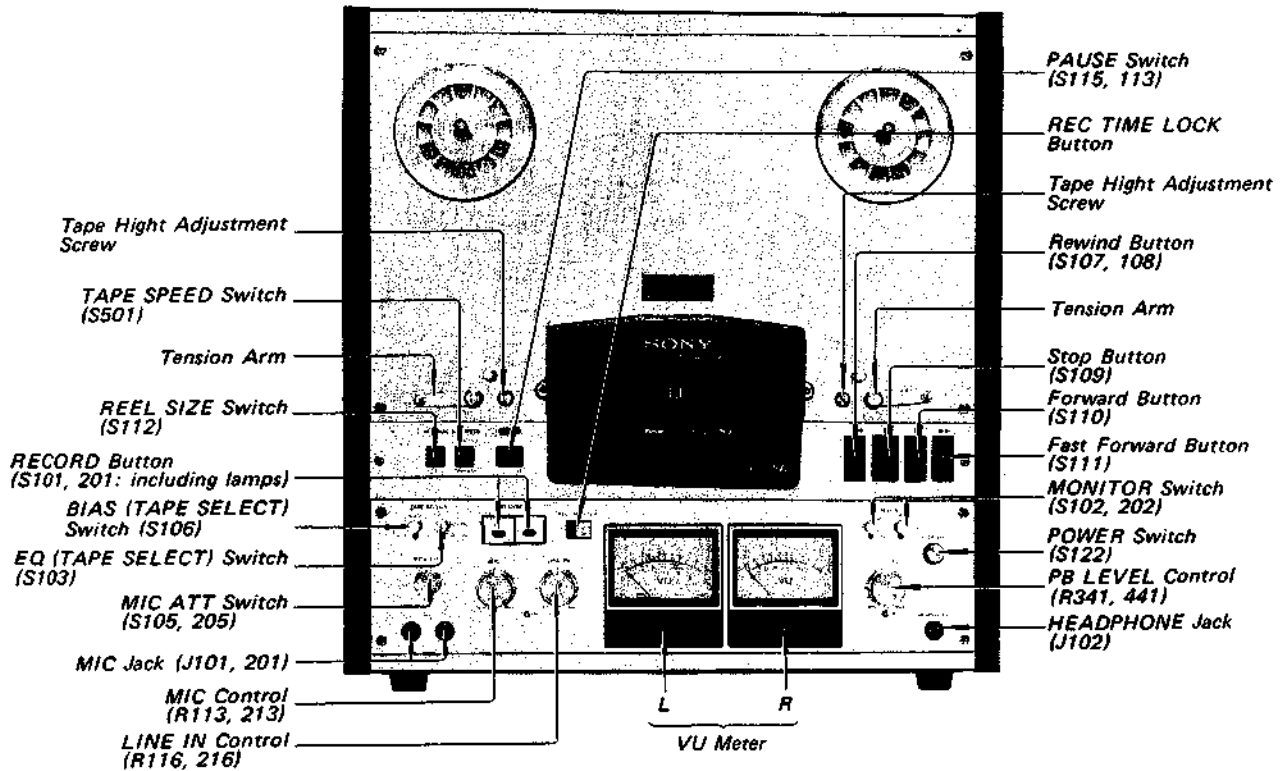

## 1-3. INTERNAL VIEW (1)

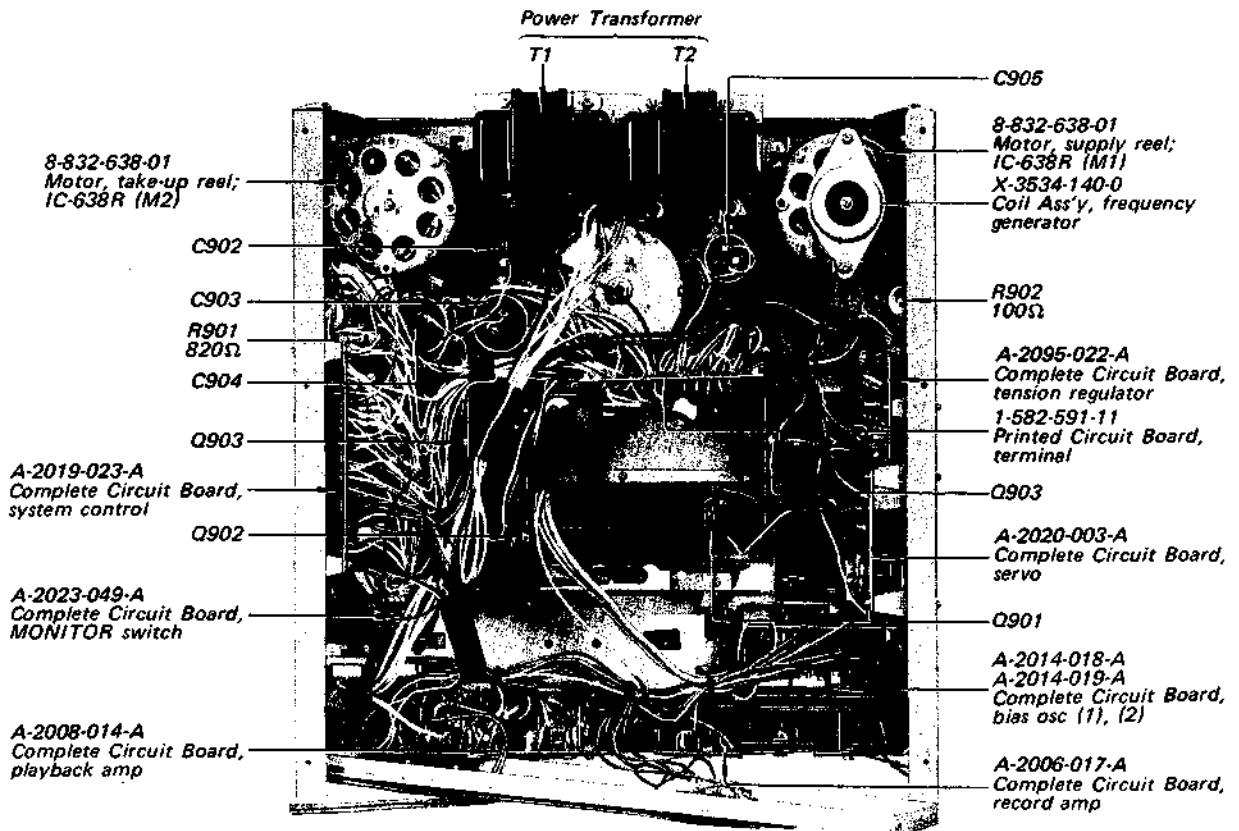

**1-4. INTERNAL VIEW (2)**

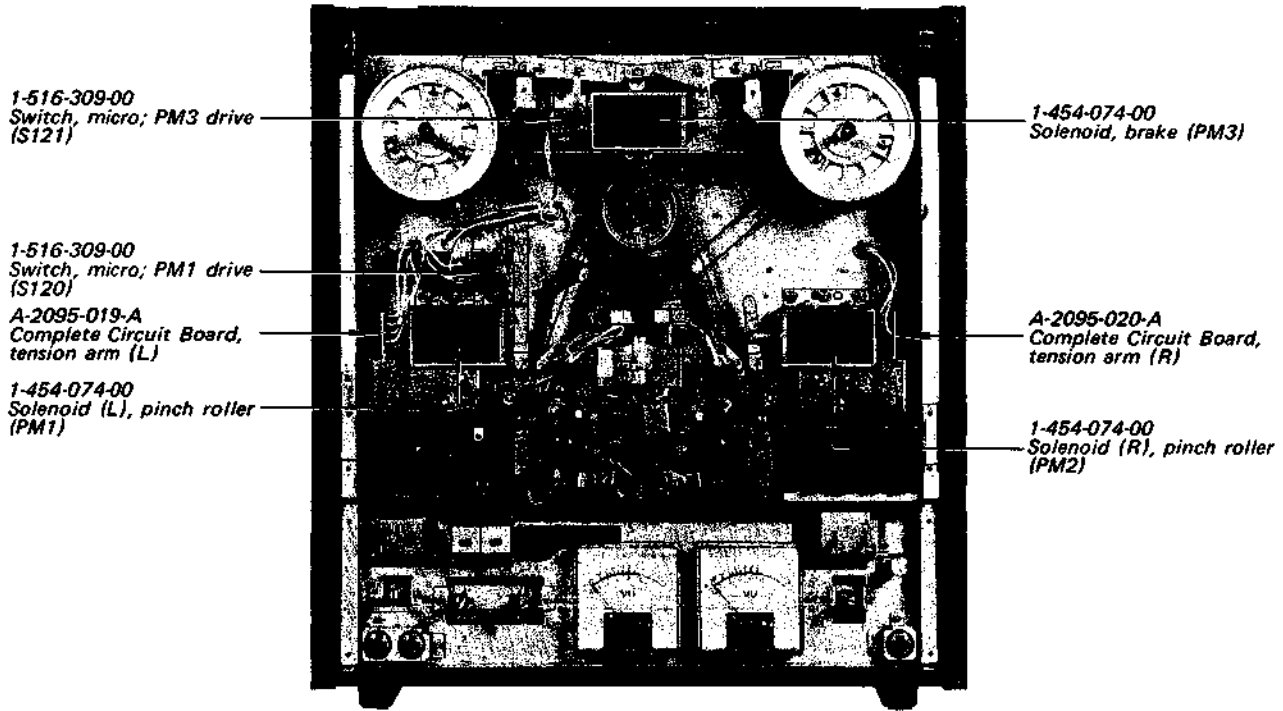

**1-5. INTERNAL VIEW (3)**

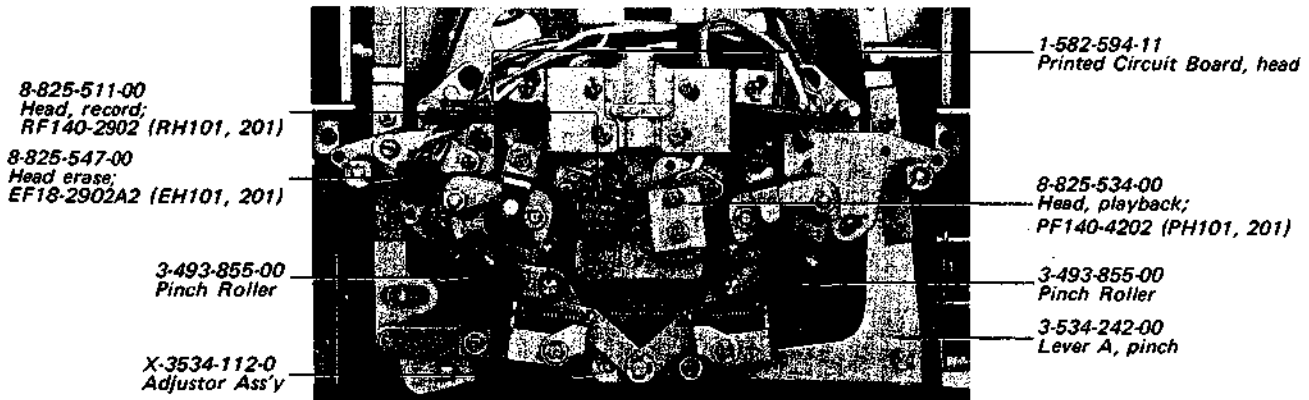

**1-6. INTERNAL VIEW (4)**



## 1-7. NOTES ON OPERATION

1. For 270 mm (10½ inch) metal reel, use a reel spacer and a Sony Reel Adaptor RAD-10.
2. Thread a tape as illustrated. Be sure to pass the tape under the tension-arm guides, and above the tape guides.

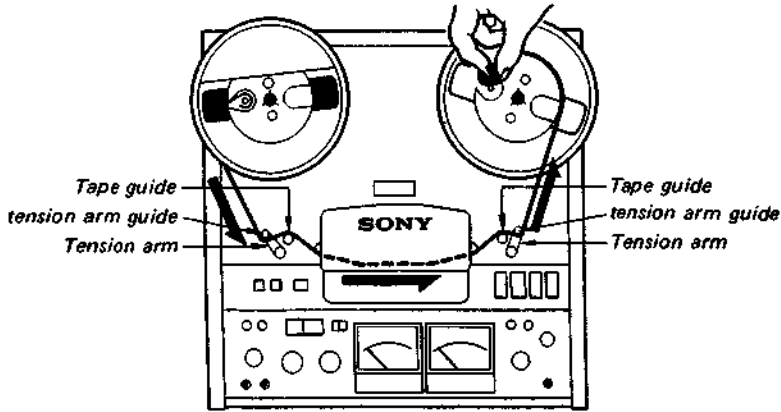

3. For protection against the high bias voltage the upper head cover is fastened with the two head cover bosses.
4. Set the BIAS and EQ (TAPE SELECT) switches according to the tape used.

Tapes	BIAS	EQ
SONY PR other regular tapes	NORMAL	NORMAL
SONY SLH MAXELL LNE 35 BASF 35 LH SCOTCH 212, CLASSIC TDK SD 150 AGFA PE 36 other Low-noise High-output tapes	NORMAL	SPECIAL
Sony Ferri-Chrome Tape	NORMAL	Fe-Cr
SCOTCH 206, 218	HIGH	NORMAL

5. Do not leave the TC-755A in PAUSE mode for a long time, since the normal rated voltages are still applied to the reel motors in PAUSE mode. Place the TC-755A in stop mode instead.
6. REC TIMER LOCK button can be moved to the right only when L and/or R RECORD buttons are pushed in stop mode. Once the RECORD buttons are locked, they cannot be released and remain illuminated even though any function button (stop, fast forward, rewind or forward button) is pushed. The TC-755A can be placed in record mode only by pushing the forward button, but not by pushing the stop, fast forward or rewind button.
7. Before setting the timer-activated recording, be sure to turn POWER switch OFF. Otherwise the tension arms may be turned OFF by the momentary tape slack and the TC-755A may be placed in stop mode.
8. PB LEVEL controls adjust the playback signal level at the LINE OUTPUTS and the HEADPHONE jack. This adjustment reflects on VU meters with a 0 VU reading corresponding to 0.43 volt output. During normal use, set the inner knob (R channel) to the center click position and align the outer knob (L channel) with the inner knob.
9. The TC-755A is designed only for vertical use, and therefore no rubber feet are provided for horizontal use.
10. All function buttons except the stop button have self lock mechanisms.

**1-8. NOTES ON REPAIR**

**1. Disassembly**

To remove the reel panel, unscrew the 14 screws indicated by ★ in the photo below. To remove the cabinet, unscrew the 10 screws attached to the cabinet (4 screws on both sides and 6 screws on the back).

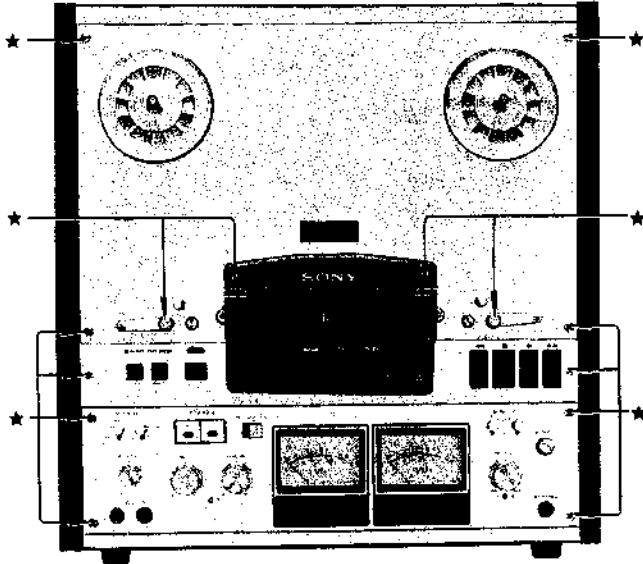

**2.** When turning the tape height adjustment screw, the following precaution must be taken: After the screw is turned clockwise as far as it will go, it must not be turned counterclockwise more than 3½ turns. The tape height may be adjusted with this screw within these limits. If the screw is turned beyond these limits, the washer indicated by \* will be damaged. (See photo.)

The screw indicated by ▲ has been adjusted at the factory and should not be turned. If, however, it happens to be turned, care must be taken that the microswitch (S117) is not touched by the tension arm spacer even if the tape height adjustment screw is turned within the limits mentioned above. Otherwise S117 will be damaged.

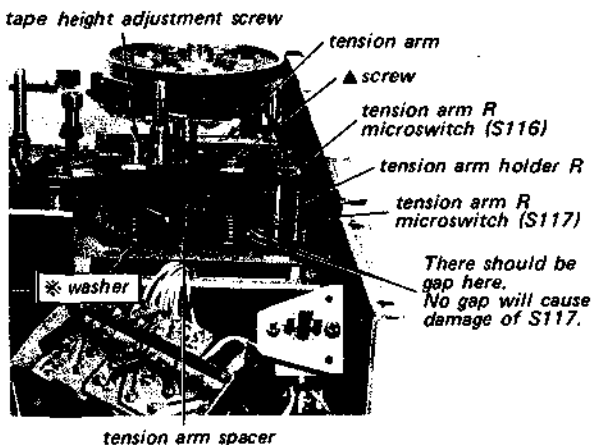

**SECTION 2  
ADJUSTMENTS**

**2-1. MECHANICAL ADJUSTMENTS**

**1. Brake Adjustment (1)**

Perform this adjustment for both left and right brakes. After the adjustment, apply locking compound to the adjusted screw.

– Playback mode –

*adjustment screw*  
Adjust the brake adjusting plate for the appropriate brake stroke.

– Right side –

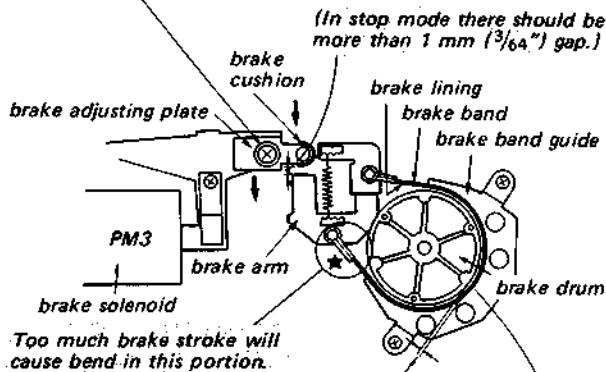

Too much brake stroke will cause bend in this portion.

In playback mode (When PM3 solenoid is energized,) the gap between the brake drum and the brake lining should uniformly be more than 0.5 mm (1/32").

In playback mode (When PM3 solenoid is energized,) the brake band should uniformly contact the brake band guide.

– Left side –

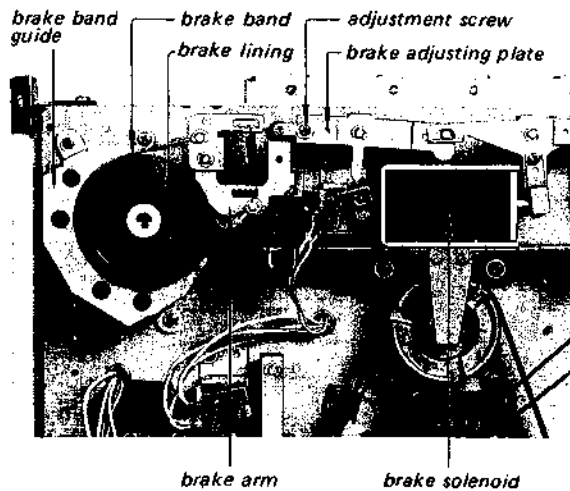

**2. Brake Adjustment (2)**

Perform this adjustment for both left and right brakes. After the adjustment, apply locking compound to the adjusted screw.

Specification:

Take-up Reel	Supply Reel	Brake Torque
clockwise	counterclockwise	1,800~2,500 g·cm (25.0~34.8 oz·inch)
counterclockwise	clockwise	600~700 g·cm (8.3~9.7 oz·inch)

– Stop mode –

– Right side –

Change the hooking position of the spring for the specified brake torque.

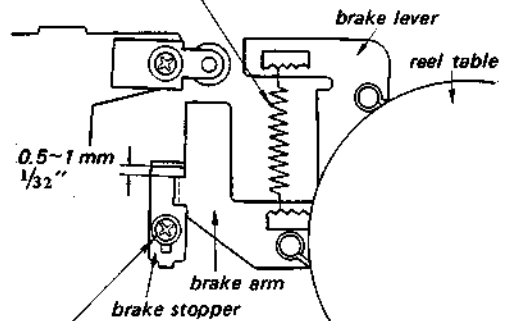

*adjustment screw*  
Adjust the brake stopper for the specified clearance.

– Left side –

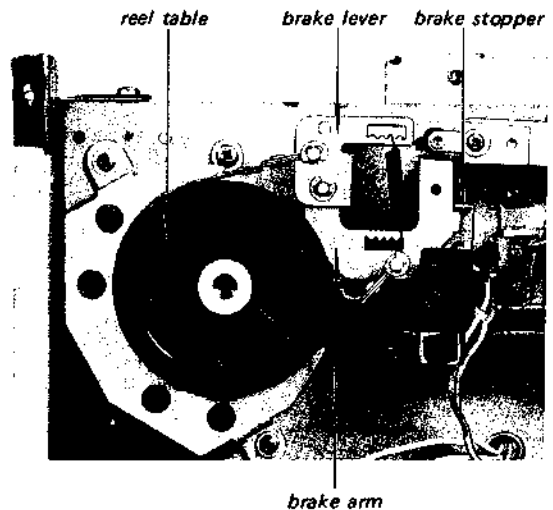



**3. Adjustor Adjustment**

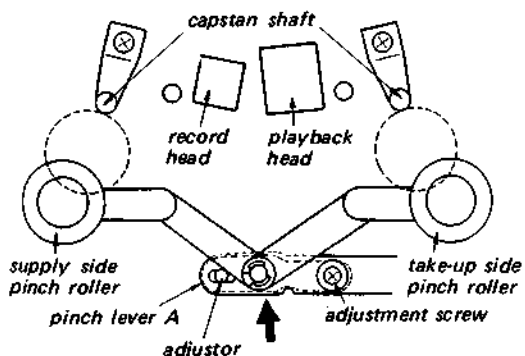

In playback mode and with PAUSE switch to ON, slowly push the pinch lever A in the direction shown by the arrow. When the supply side pinch roller contacts the capstan shaft and starts to rotate, the gap between the take-up side pinch roller and the capstan shaft should be less than 0.5 mm ( $1/64$ "), so that the take-up side pinch roller starts rotating slightly after or almost simultaneously with the start of the supply side pinch roller, if necessary, adjust the adjustor.

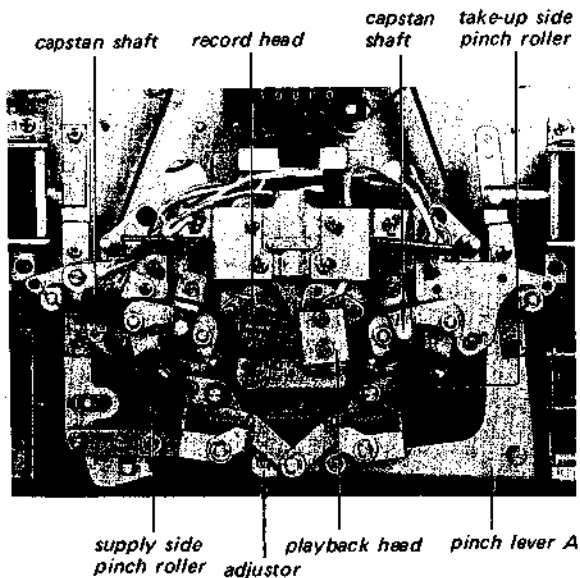

**4. Pinch Roller Solenoid (R) (PM2) Position Adjustment**

After the adjustment, apply locking compound to the adjusted screws.

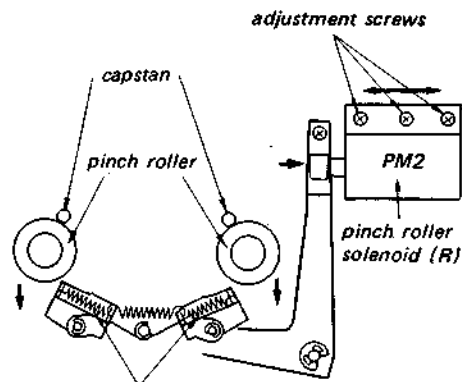

*These two springs should expand 0.5 mm ( $1/64$ ") longer after the pinch rollers contact the capstans in playback mode. If necessary, adjust the PM2 solenoid position.*

Specification for your reference:

Pinch roller pressure: 1000 g ~ 1600 g (2 lb 3 oz ~ 3 lb 8 oz)

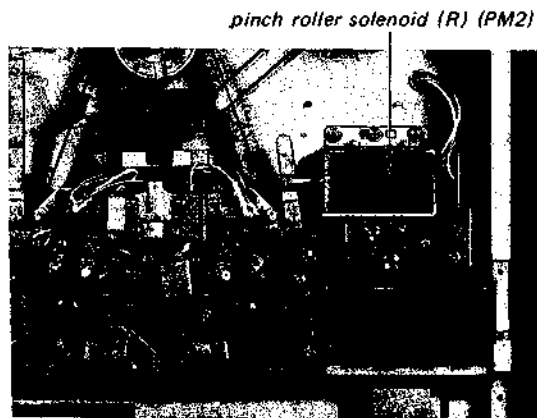

**5. Pinch Roller Solenoid (L) (PM1) Position Adjustment**

After the adjustment, apply locking compound to the adjusted screws.

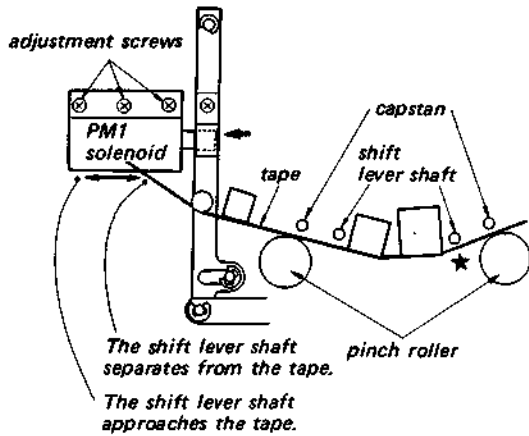

With a tape threaded along the tape path and in playback mode (PM1 solenoid should be energized), turn PAUSE switch ON. At this time the shift lever shafts should not contact the tape and the pinch rollers should separate from the capstans. If necessary, adjust the PM1 solenoid position.

**Note:** The shift lever shaft indicated by ★ in the above figure may slightly contact the tape but the other should not.

*Pinch Roller Solenoid (L) (PM1)*



**6. RECORD Button Lock Adjustment**

After the adjustment, apply locking compound to the adjusted screw.

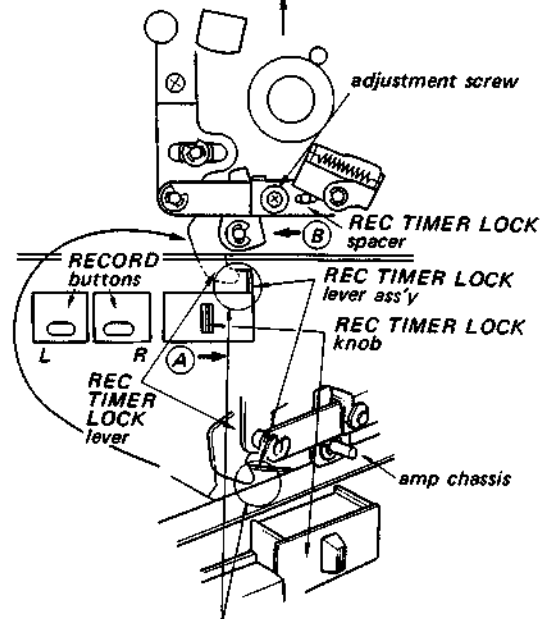
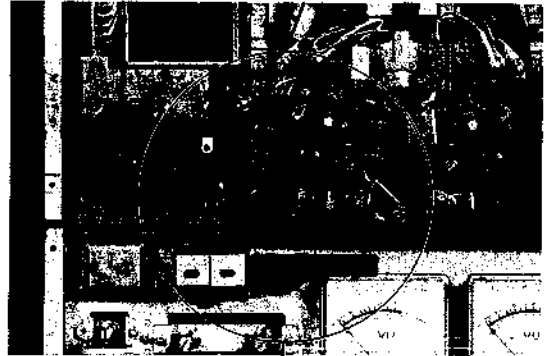

Push L and R RECORD buttons, move REC TIMER LOCK knob in the direction shown by arrow (A) and then push the 'forward' button. At this time REC TIMER LOCK lever should slightly contact REC TIMER LOCK lever ass'y as shown. If necessary, adjust the REC TIME LOCK spacer.

**Note:**

After the adjustment, and with the L and R RECORD buttons pushed and the REC TIMER LOCK knob pushed in the direction shown by arrow (A), and also the forward button pushed, make sure of the following functions.

1. RECORD buttons cannot be released by releasing REC TIMER LOCK knob.
2. REC TIMER LOCK knob cannot be released by moving the REC TIMER LOCK knob further in the direction shown by the arrow (A).
3. Push L and R RECORD buttons and then push forward button. At this time the RECORD buttons should not be released.
4. In stop mode L and R RECORD buttons should be released.
5. When L and R RECORD buttons are released, REC TIMER LOCK knob cannot be moved in the direction shown by the arrow (A).

**7. Actuator Adjustment (1)**

Perform this adjustment after the Pinch Roller Solenoid (L) (PM1) Position Adjustment. After the adjustment, apply locking compound to the adjusted screw.

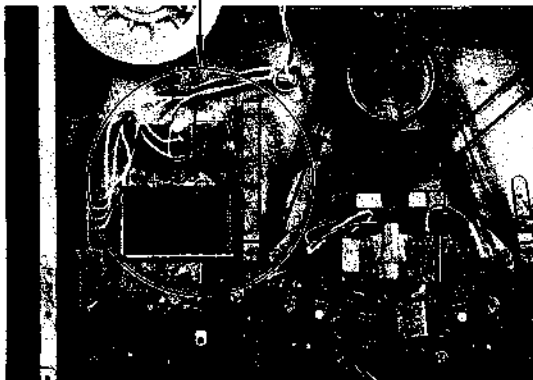
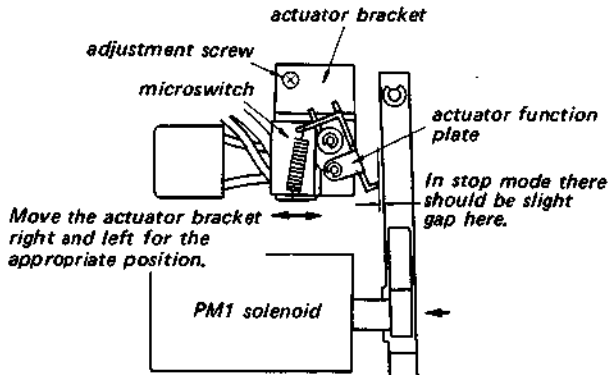

**Note:** The microswitch should turn OFF (click) in 0.5 to 2 seconds after forward button is pushed.

**8. Actuator Adjustment (2)**

Perform this adjustment after the Brake Adjustments (1) and (2). After the adjustment, apply locking compound to the adjusted screw.

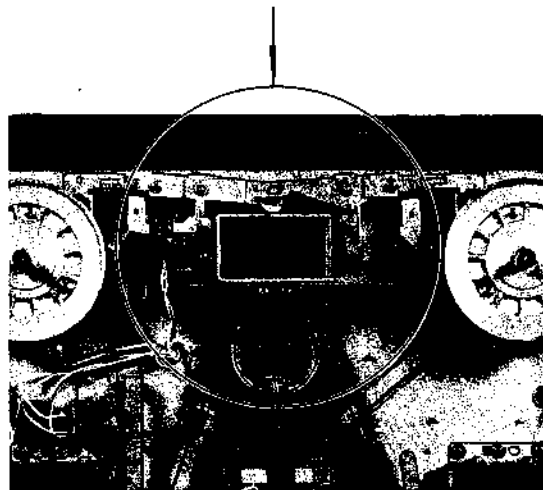
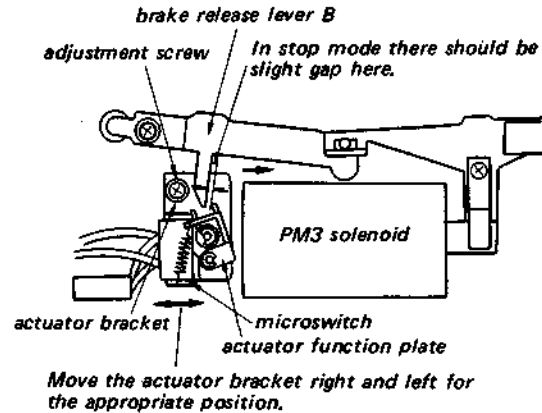

**Note:** The microswitch should turn OFF (click) in 0.5 to 2 seconds after forward button is pushed.

**9. Fast Forward and Rewind Back-Tension Adjustment**

1. Supply the rated power voltage.
2. Fasten the tension arms with rubber bands as shown, thus activating them.
3. Pull the spring scale at a speed of between 9.5 cm/s to 19 cm/s in the direction shown by the arrow for rewind or fast forward mode with REEL SIZE switch at "7" and "10". Measure the back tension torque for rewind and fast forward modes. Torques should be as shown in the following table.

**Specification:**

Mode	REEL SIZE Switch	Back-Tension Torque
rewind	10	110 to 140 g · cm (1.53 to 1.95 oz · inch)
	7	80 to 100 g · cm (1.11 to 1.39 oz · inch)
fast forward	10	110 to 140 g · cm (1.53 to 1.95 oz · inch)
	7	80 to 100 g · cm (1.11 to 1.39 oz · inch)

If necessary, adjust the torque by moving the sliders of the adjustable resistor (R901).

— Right side —

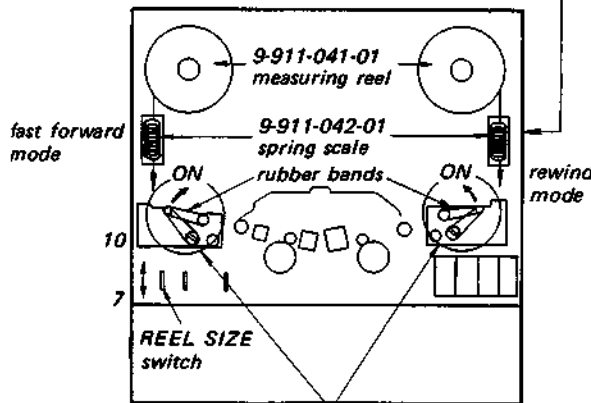
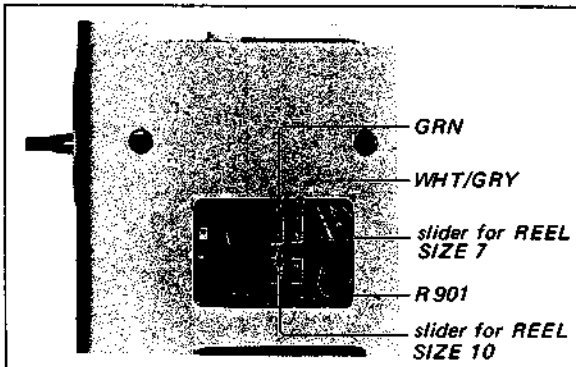

Fasten the tension arms with rubber bands to operate the unit.

**10. Playback Take-up Torque Adjustment**

1. Supply the rated power voltage.
2. Fasten the tension arms with rubber bands as shown, thus activating them.
3. Turn the TAPE SPEED switch to "19 cm 7½."
4. Place the unit in playback mode.
5. Pull the spring scale in the direction shown by the arrow and measure the take-up torque with REEL SIZE switch at "10" and "7". Torques should be as shown in the following table.

**Specification:**

REEL SIZE switch	Take-up Torque
10	580 to 620 g · cm (8.06 to 8.61 oz · inch)
7	280 to 320 g · cm (3.89 to 4.44 oz · inch)

If necessary, adjust the torque by moving the sliders of the adjustable resistor (R902).

— Left side —

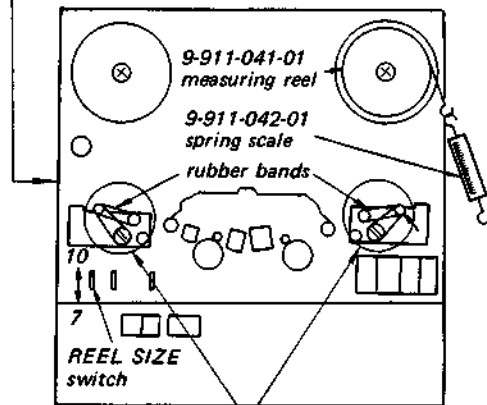
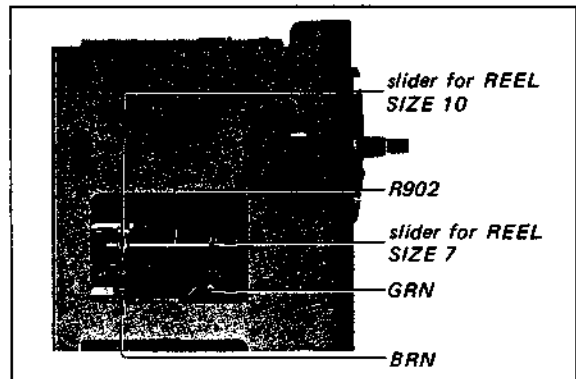

Fasten the tension arms with rubber bands to operate the unit.

**11. Reel Table Height Adjustment**

After the adjustment, apply locking compound to the adjusted screws.

1. Thread the tape from a 180 mm (7 inches) plastic reel as shown.
2. Fasten the tension arms with rubber bands as shown.
3. Adjust the reel table height so that the tape travels in the center of both reel flanges in fast forward and rewind modes.

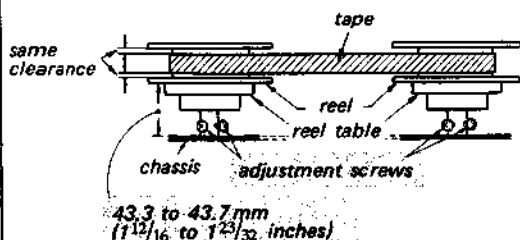
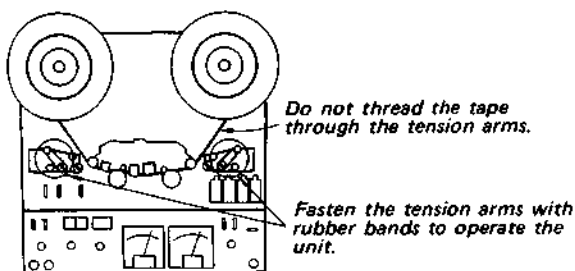

**12. Tape Guides Adjustment (1)**

1. Thread the tape from a 180 mm (7 inches) plastic reel as shown.
2. Turn the two screws indicated by ★ counterclockwise until it stops, and then turn them clockwise in 1 ¼ turns.
3. Turn the two screws indicated by ● so that the tape travels in the center of both reel flanges in rewind and fast forward modes.
4. Turn the two tape guides indicated by ▲, for fine adjustment, so that the tape travels in the center of the guides without tape curl in playback mode.
5. When the tape curls, repeat the above steps.

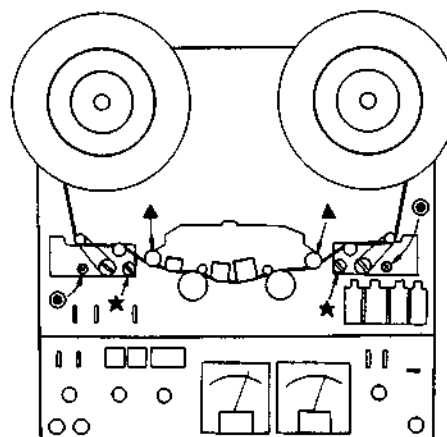

**13. Tape Guide Adjustment (2)**

Perform this adjustment after the reel table height adjustment and the tape guides adjustment (1) are completed. Tape should not curl at each tape guide B, C, and E.

- Note:** 1. Make sure that the three heads are correctly positioned as specified. If necessary, perform the head height adjustments on page 19 and 21.
2. If all the tape guides B, C and E are not correctly positioned, adjust them so that the tape travels in the center of the pinch roller.

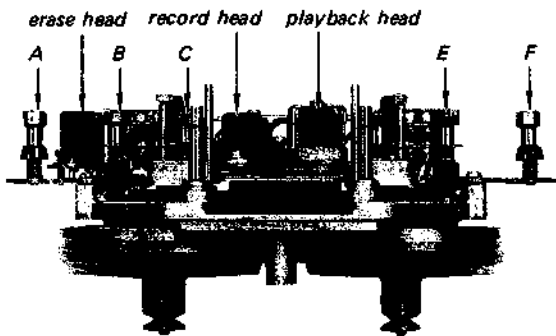
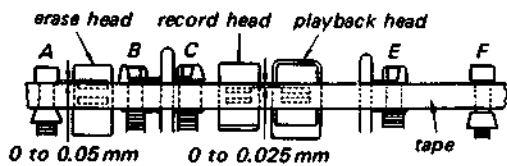

**14. Tape Shifter Position Check.**

Perform this check for both left and right shifters with the unit in horizontal position.

1. In playback mode the shift levers should not touch the head deck.

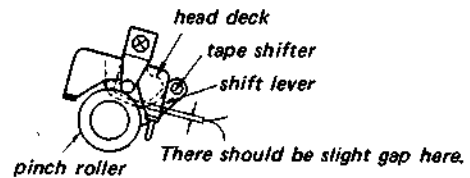

2. At tape end in rewind and fast forward modes, there should be more than 2 mm ( $\frac{3}{32}$  inch) gap between the tape and the record and playback heads. At this time the tape may touch the erase head.

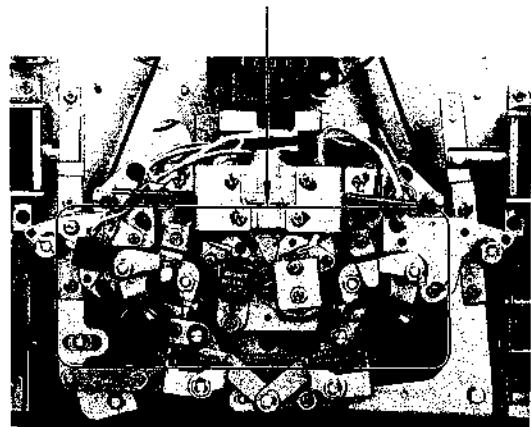
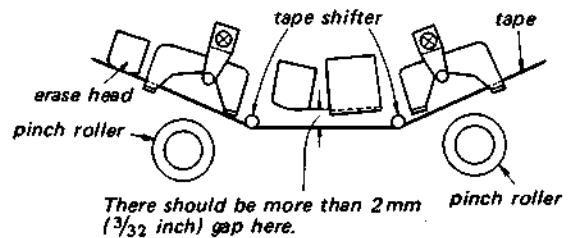

**15. Function Switch Operation Check**

1. Push the POWER switch ON with the tension arms released. Next push each function button. No operation should take place, and each function button should not lock.
2. When the tension arm L and/or R are activated, the stop solenoid should be de-energized. The solenoid can be seen when looked at in the direction of the arrow indicated by \*. When the solenoid is de-energized, a click can be heard.
3. Activate the tension arm L or R, and make sure of the following functions.
  - 3-1. Push the forward button. The button should lock. When the activated tension arm is released, the locked button should release itself
  - 3-2. Push the forward button. Then push the stop button. At this time, the locked forward button should release itself.
  - 3-3. Push the forward button. Then push the POWER switch OFF. The locked forward button should remain locked. Next push the POWER switch ON. The forward button should still remain locked.
  - 3-4. Push the fast forward button. The button should lock. When the activated tension arm is released, the locked button should release itself.
  - 3-5. Push the fast forward button. Then push the stop button. At this time the locked button should release itself.
  - 3-6. Push the rewind button. The button should lock. When the activated tension arm is released, the locked button should release itself.
  - 3-7. Push the rewind button. Then push the stop button. At this time the locked button should release itself.

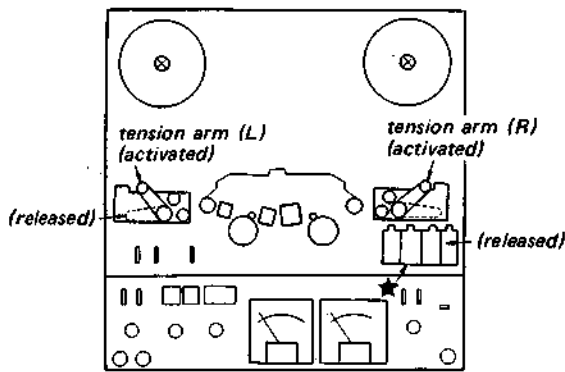

**16. Tension Regulator Adjustment (Not normally performed)**

**Note:** For this adjustment a super low frequency oscillator (3 Hz to 10 Hz) is required. Without the oscillator, do not perform this adjustment and only replace the defective parts. When adjusting adjustable resistors, turn them in the direction of increasing torque, so that the torque rises to the specified value.

1. Supply the rated power voltage.
2. Unsolder the three lead wires of the FG (frequency generator) coil in the supply reel motor M1, connect a super low frequency oscillator of 1Vp-p output across R701 through a 100µF electrolytic capacitor.
3. Set TAPE SPEED switch to "9.5 cm 3/4" and REEL SIZE switch to "10".
4. Adjust the oscillator frequency so that the voltage between the emitter of Q712 transistor and the chassis ground is 9 volts in playback mode.
5. With the frequency adjusted in step 4, adjust R731 so that the supply motor torque is 250 g·cm (3.47 oz·inch).
6. Change the oscillator frequency to 10 Hz and adjust R717 so that the torque is 80 g·cm (1.11 oz·inch).
7. Change the oscillator frequency to 3.3 Hz and adjust R736 so that the torque is 310 g·cm (4.30 oz·inch).
8. Repeat steps 6 and 7 once more.
9. Set TAPE SPEED switch to "19 cm 7/2" and change the oscillator frequency to 6.6 Hz. Then adjust R737 so that the torque is 310 g·cm (4.30 oz·inch).

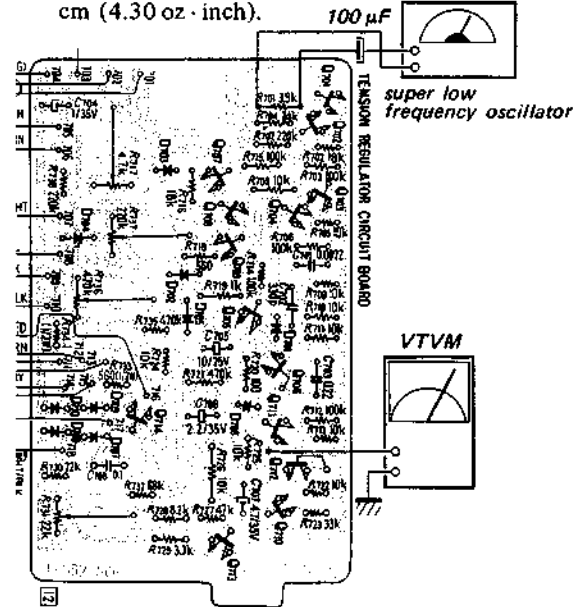

## 2.2. ELECTRICAL ADJUSTMENTS

### Precaution:

1. Clean the following parts with a swab moistened with alcohol:
 

record head	pinch roller
playback head	rubber belts
erase head	idlers
capstan	tape guides
2. Demagnetize record, playback and erase heads with a head demagnetizer.
3. Do not use magnetized screwdriver for adjustments.
4. After adjustments, apply locking compounds to the adjusted parts.
5. Adjustments should be performed in the order listed in this service manual.
6. Adjustments and measurements should be performed for each L and R channel with the rated power supply voltage unless otherwise specified.
7. Switches and controls, which are not given in "Settings" for the each adjustment, can be set in any modes or positions. Power switch, however, should be ON unless otherwise noted.

### Test Equipment/Tools Required:

- audio oscillator (af osc)
- VTVM
- VOM
- attenuator (600Ω)
- digital frequency counter or speed checker (SONY LFM-30)
- oscilloscope
- resistors: 600 Ω, 10 kΩ, 100 kΩ
- SONY test tape
- J-19-F2

Tone:	1	2	3	4	5	6	7
Frequency: (Hz)	400	400	10 k	12.5 k	7 k	80	40
Level (dB):	0	-10	-10	-10	-10	-10	-10

- J-19-A2 (12.5 kHz, -10 dB)
- SPC-47 (4 kHz, 0 dB)
- blank tapes (completely erased)
- NPS-1 (for NORMAL record)
- SLH-S1 (for SPECIAL record)

### Normal Input Level

	Impedance	Level
MIC	300 Ω	-60 dB (0.77 mV)
LINE IN	10 kΩ	-10 dB (0.25V)

### Normal Output Level

	Load Impedance	Level
LINE OUT	100 kΩ	-5 dB (0.44 V)
HEADPHONES	8 Ω	-28 dB (31 mV)

### 1. B + 25 V Adjustment

#### Settings:

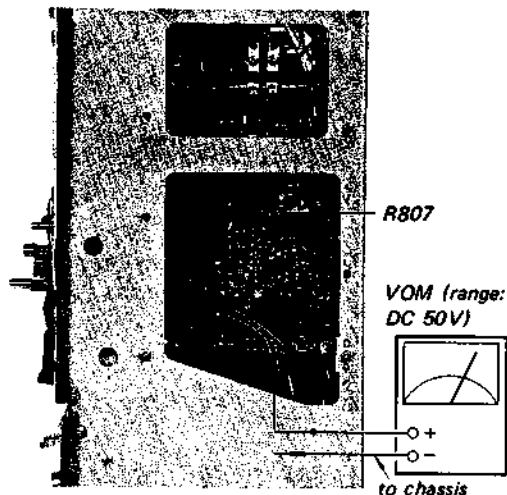

#### Procedure:

Adjust R807 for 25 V DC on VOM.

**Note:** The ripple voltage should be less than 1 mV p-p.



## 2. Tape Speed Adjustment

### Settings:

REEL SIZE switch: 7  
 TAPE SPEED switch: 19 cm, 7½ and 9.5 cm, 3¾  
 EQ (TAPE SELECT) switch: NORMAL  
 MONITOR switch: TAPE  
 PB LEVEL control: mechanical mid

### Procedure:

Mode: playback

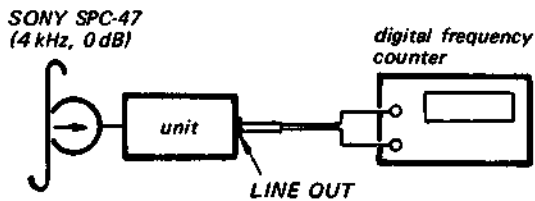
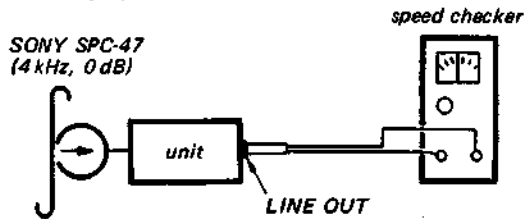

TAPE SPEED	Adjust	Specification	
		speed checker	digital frequency counter
19 cm, 7½	R616	-1 ~ +1%	3,960 ~ 4,040 Hz
9.5 cm, 3¾	R618	-1 ~ +1%	1,980 ~ 2,020 Hz

### Adjustment Location:

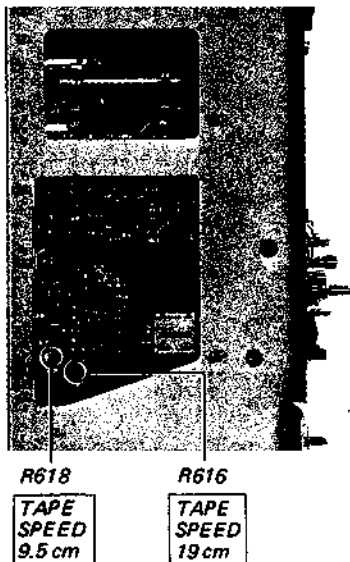

## 3. Meter Level Adjustment

### Settings:

EQ (TAPE SELECT) switch: NORMAL  
 MONITOR switch: SOURCE  
 PB LEVEL control: mechanical mid

### Procedure:

1. Calibrate the level meters for 0% indication with POWER switch OFF.
2. Adjust LINE IN control for -5 dB (0.44 V).

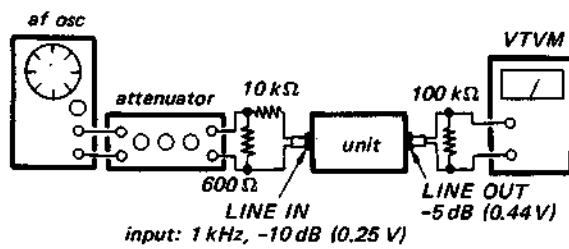

3.

Adjust	Remarks
R336 (L channel)	0 VU on the level meters
R436 (R channel)	

### Adjustment Location:

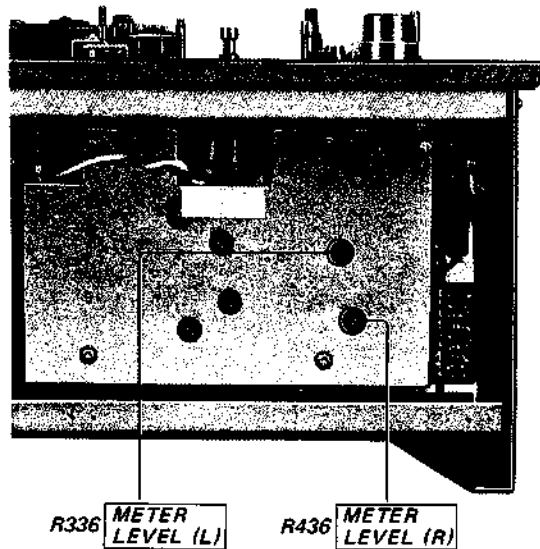

**4. Playback Head Angle Adjustment**

**Settings:**

- REEL SIZE switch: 7
- TAPE SPEED switch: 19 cm, 7½
- EQ (TAPE SELECT) switch: NORMAL
- MONITOR switch: TAPE
- PB LEVEL control: mechanical mid

**Procedure:**

Mode: playback

SONY J-19-F2  
(3rd tone, 10 kHz -10 dB)

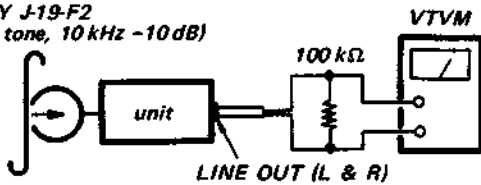

Loosen the adjustment screws and correctly position the playback head for the highest VTVM reading.

**Note:** Slightly touch the supply reel and at this time the VTVM reading deviation should be less than 1 dB.

**Adjustment Location:**

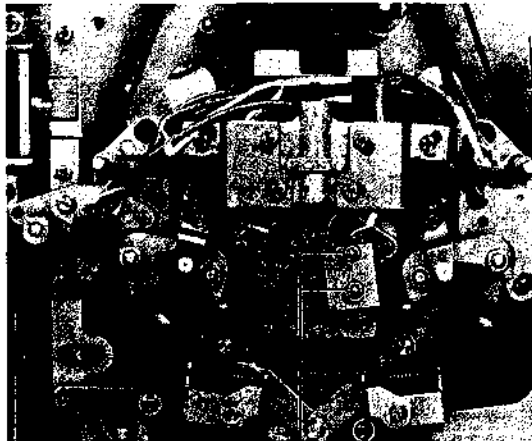

*playback head angle adjustment screws.*

**5. Playback Head Height Adjustment**

**Settings:**

- REEL SIZE switch: 7
- TAPE SPEED switch: 19 cm, 7½

**Procedure:**

Play back a tape and align the tape edge and the playback head core as shown by turning the height and zenith adjustment screws.

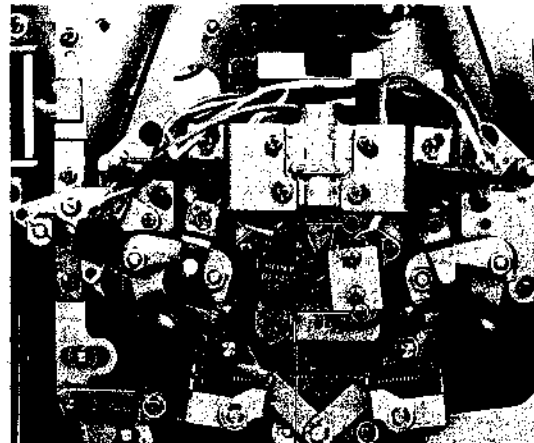
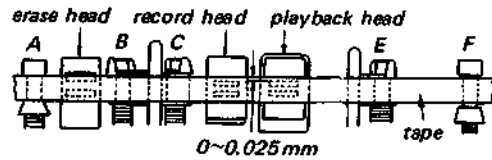

*playback head height and zenith adjustment screws.*

**6. Playback Head Azimuth and Phase Adjustments**

**Settings:**

- REEL SIZE switch: 7
- TAPE SPEED switch: 19 cm, 7 1/2
- EQ (TAPE SELECT) switch: NORMAL
- MONITOR switch: TAPE
- PB LEVEL control: mechanical mid

**Procedure:**

If an oscilloscope is available, employ Procedure 2.  
If a simplified test is to be made, follow Procedure 1.

**1. Mode: playback**

SONY J-19-A2  
(12.5 kHz, -10 dB)

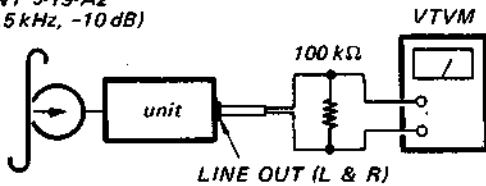

Turn the adjustment screw shown in the photo below for the highest VTVM reading. If the highest peaks for L and R do not coincide, place the adjustment screw to the mechanical mid of the two positions for the peaks.

**2. Mode: playback**

SONY J-19-A2  
(12.5 kHz, -10 dB)

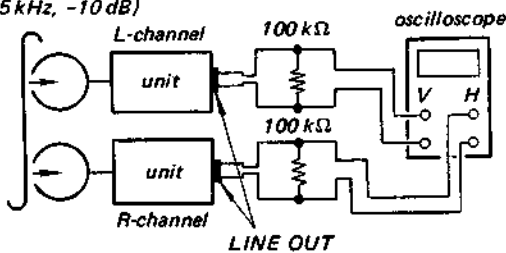

Adjust azimuth adjustment screw	On the oscilloscope			
	in-phase	30°	90°	more than 90°
	good		wrong	

**Adjustment Location:**

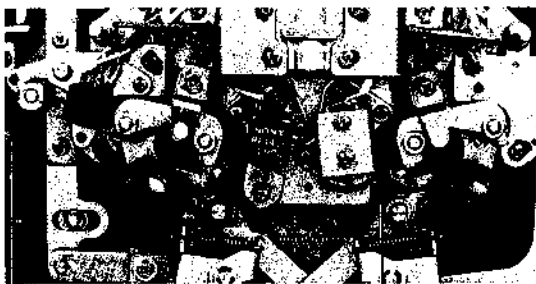

playback head azimuth adjustment screw.

**7. Playback Equalizer Adjustment**

**Settings:**

- REEL SIZE switch: 7
- TAPE SPEED switch: 19 cm, 7 1/2
- EQ (TAPE SELECT) switch: NORMAL
- MONITOR switch: TAPE
- PB LEVEL control: mechanical mid

**Procedure:**

Mode: playback

SONY J-19-F2  
(2nd tone, 400 Hz -10 dB)  
(3rd tone, 10 kHz -10 dB)

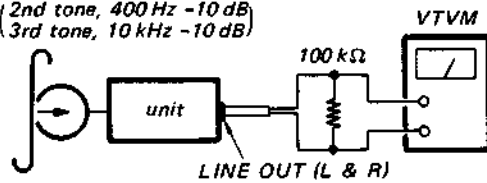

	Adjust	VTVM reading
2nd tone 400 Hz	PB LEVEL control	0 dB (0.775 V)
3rd tone 10 kHz	R311 (L channel) R411 (R channel)	-0.5 dB (0.73 V)

Specification for your reference in case of a more detailed test:

J-19-F2 (TAPE SPEED: 19 cm, 7 1/2)		J-9-F1 (TAPE SPEED: 9.5 cm, 3 3/4)	
400 Hz	0 dB (standard)	400 Hz	0 dB (standard)
10 kHz	-0.5 ± 1 dB	5 kHz	0 ± 2 dB
12.5 kHz	-0.5 ± 1.5 dB	3 kHz	0 ± 1.5 dB
7 kHz	-0.5 ± 1.5 dB	200 Hz	0 ± 1.5 dB
80 Hz	+2 ± 2 dB	80 Hz	+1 ± 2 dB
40 Hz	+1.5 ± 2 dB		

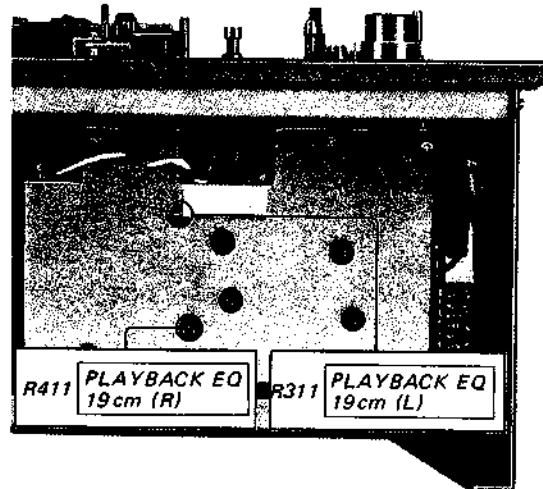

## 8. Playback Level Adjustment

### Settings:

REEL SIZE switch: 7  
 TAPE SPEED switch: 19 cm, 7½  
 EQ (TAPE SELECT) switch: NORMAL  
 MONITOR switch: TAPE  
 PB LEVEL control: mechanical mid

### Procedure:

Mode: playback

SONY J-19-F2  
 (1st tone, 400 Hz 0 dB)

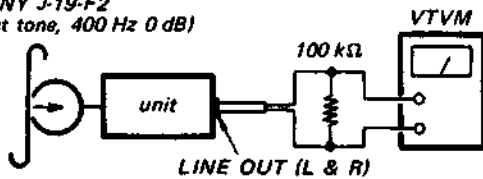

Adjust	VTVM reading
R317 (L channel)	-5 dB (0.44V) allowance: ±1 dB
R417 (R channel)	

- Note:**
- Turn the EQ (TAPE SELECT) switch to SPECIAL position and make sure that the output level lowers by 2.4 ± 1 dB.
  - Difference between L and R channels should be within 1 dB.

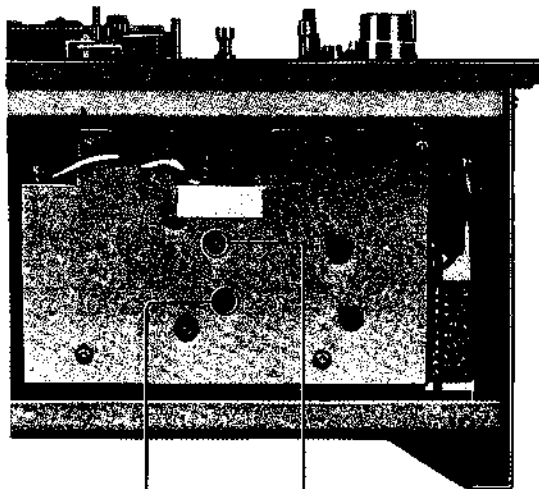

R417 PLAYBACK LEVEL (R)

R317 PLAYBACK LEVEL (L)

## 9. Record Head Angle Adjustment

### Settings:

REEL SIZE switch: 7  
 TAPE SPEED switch: 19 cm, 7½  
 BIAS (TAPE SELECT) switch: NORMAL  
 EQ (TAPE SELECT) switch: NORMAL  
 MONITOR switch: TAPE  
 LINE IN control: mechanical mid  
 PB LEVEL control: mechanical mid

### Procedure:

Mode: record and simultaneous playback

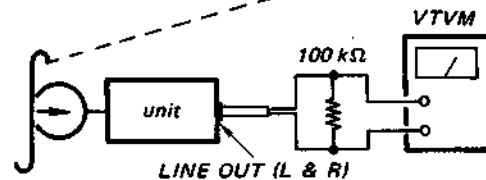
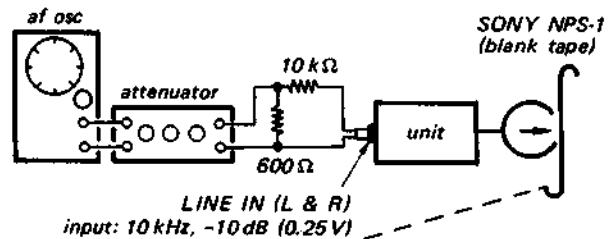

Loosen the adjustment screws and correctly position the record head for the highest VTVM reading.

**Note:** Slightly touch the supply reel and at this time the VTVM reading deviation should be less than 1 dB.

### Adjustment Location:

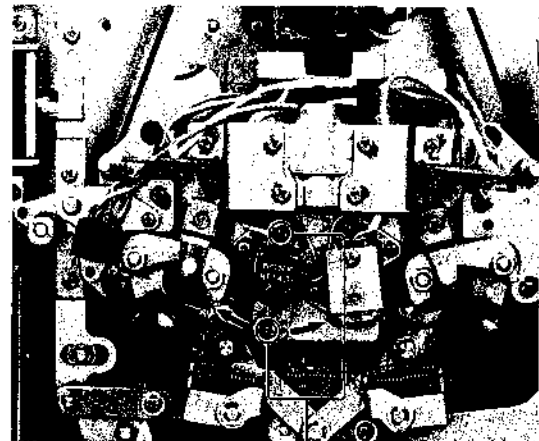

record head angle adjustment screws

**10. Record Head Height Adjustment**

**Settings:**

- REEL SIZE switch: 7
- TAPE SPEED switch: 19 cm, 7½
- BIAS (TAPE SELECT) switch: NORMAL
- EQ (TAPE SELECT) switch: NORMAL
- MONITOR switch: TAPE
- LINE IN control: mechanical mid
- PB LEVEL control: mechanical mid

**Procedure:**

Mode: record and simultaneous playback

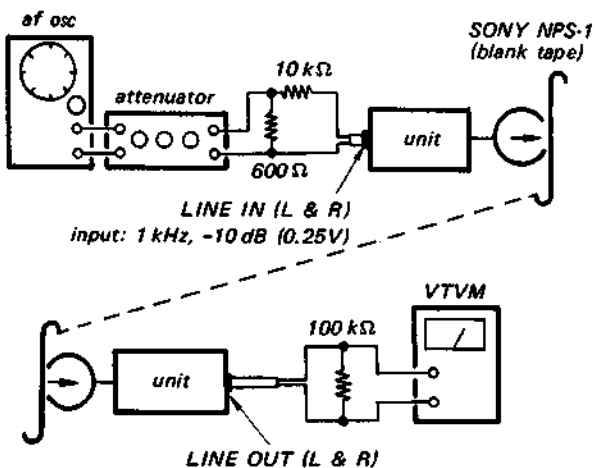

Turn the height and zenith adjustment screws for the highest VTVM reading.

**Adjustment Location:**

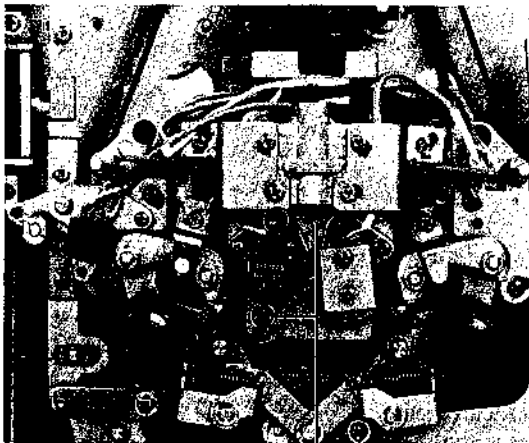

record head height and zenith adjustment screws

**11. Record Head Azimuth and Phase Adjustments**

**Settings:**

- REEL SIZE switch: 7
- TAPE SPEED switch: 19 cm, 7½
- BIAS switch: NORMAL
- TAPE SELECT (EQ) switch: NORMAL
- MONITOR switch: TAPE
- LINE IN control: mechanical mid
- PB LEVEL control: mechanical mid

**Procedure:**

When an oscilloscope is available, employ Procedure 2. When a simplified test is made, follow Procedure 1.

1. Mode: record and simultaneous playback

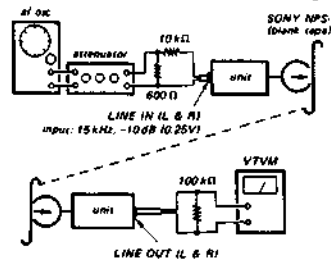

Turn the adjustment screw for the highest VTVM reading. If the highest peaks for L and R do not coincide, place the adjustment screw to the mechanical mid of the two positions for the peaks.

2. Mode: record and simultaneous playback

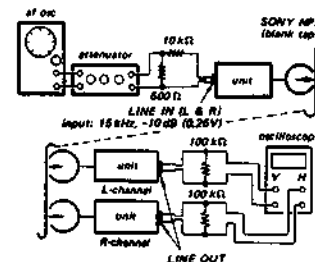

Adjust	On the oscilloscope			
skew with adjustment screw				
	in-phase	30°	90°	more than 90°
		good		wrong

Note: Difference between the highest levels of L and R and the finally adjusted level should be within 1 dB.

**Adjustment Location:**

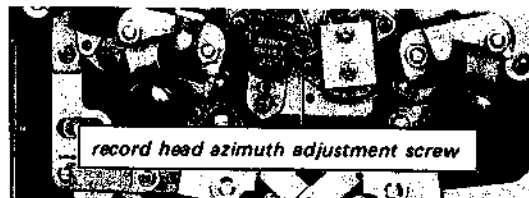

record head azimuth adjustment screw

**12. Bias Trap Adjustment**

Settings:

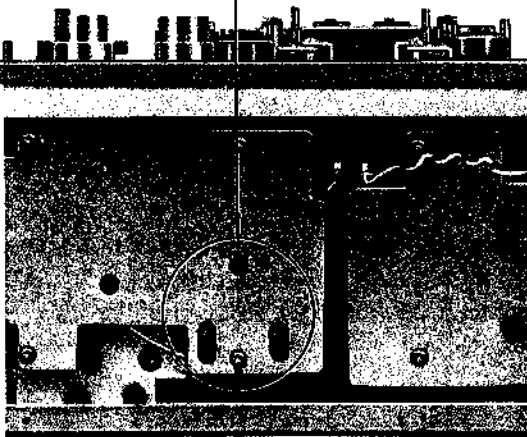
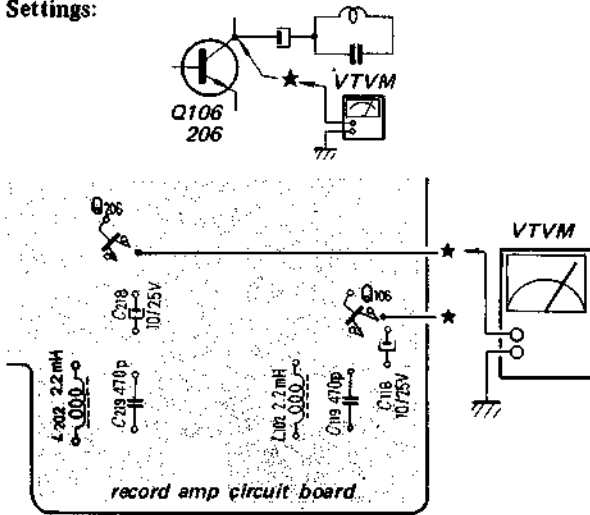

Procedure:

In record mode turn L102 (L-channel) and L202 (R-channel) for the lowest VTVM reading (-40 dB (7.7 mV) or less).

Adjustment Location:

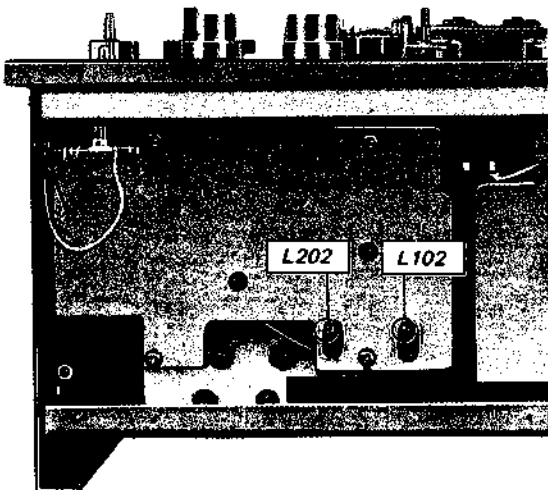

**13. Record Bias Adjustment**

Settings:

- REEL SIZE switch: 7
- TAPE SPEED switch: 19 cm 7 1/2
- BIAS (TAPE SELECT) switch: NORMAL
- EQ (TAPE SELECT) switch: SPECIAL
- MONITOR switch: TAPE
- LINE IN control: mechanical mid
- PB LEVEL control: mechanical mid

Procedure:

Mode: record and simultaneous playback

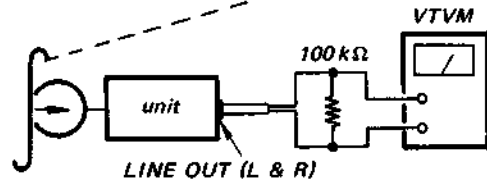
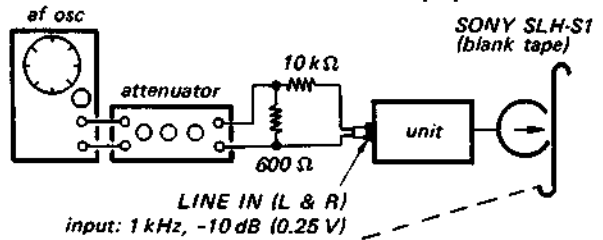

As trimmer capacitor C511 (L-channel) or C512 (R-channel) is slowly turned clockwise, VTVM reading will go up to a maximum and then start falling again. Adjust the capacitor until VTVM reads 0.5 dB below and beyond the maximum reading.

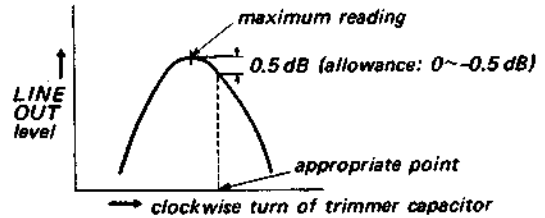

Adjustment Location:

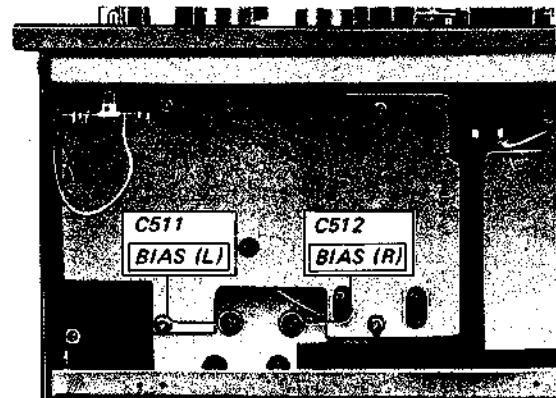

**14. Overall Frequency Response (NORMAL RECORD EQ) Adjustment**

**Settings:**

- REEL SIZE switch: 7
- TAPE SPEED switch: 19 cm 7½
- BIAS (TAPE SELECT) switch: NORMAL
- EQ (TAPE SELECT) switch: NORMAL
- MONITOR switch: TAPE
- LINE IN control: mechanical mid
- PB LEVEL control: mechanical mid

**Procedure:**

Mode: record and simultaneous playback

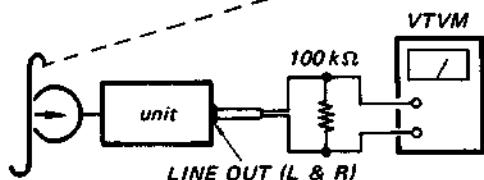
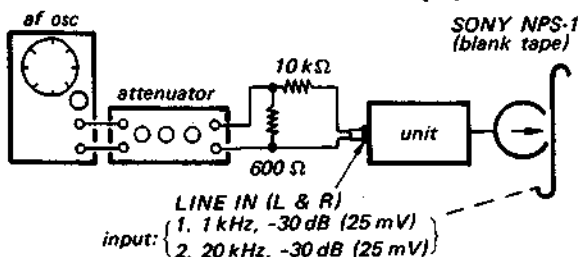

Adjust	Output	VTVM reading
L501 (L channel)	1 kHz	reference
L502 (R channel)	20 kHz	-1 dB (0.69 V)

**Adjustment Location:**

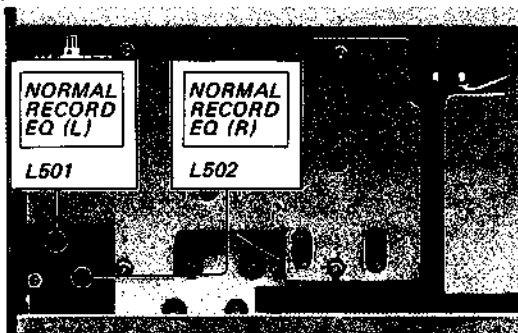

**15. Overall Frequency Response (SPECIAL RECORD EQ) Adjustment**

**Settings:**

- REEL SIZE switch: 7
- TAPE SPEED switch: 19 cm 7½
- BIAS (TAPE SELECT) switch: NORMAL
- EQ (TAPE SELECT) switch: SPECIAL
- MONITOR switch: TAPE
- LINE IN control: mechanical mid
- PB LEVEL control: mechanical mid

**Procedure:**

Mode: record and simultaneous playback

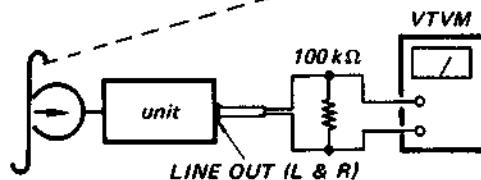
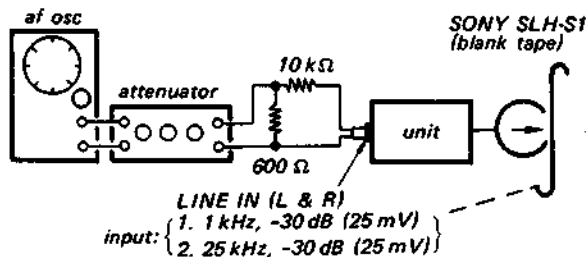

	Adjust	Remarks
1 kHz	L503 (L channel) and L504 (R channel)	Same LINE OUT level at both frequencies.
25 kHz		

**Adjustment Location:**



**16. Overall Frequency Response (Fe-Cr RECORD EQ) Adjustment**

**Settings:**

- REEL SIZE switch: 7
- TAPE SPEED switch: 19 cm 7½
- BIAS (TAPE SELECT) switch: NORMAL
- EQ (TAPE SELECT) switch: Fe-Cr
- MONITOR switch: TAPE
- LINE IN control: mechanical mid
- PB LEVEL control: mechanical mid

**Procedure:**

Mode: record and simultaneous playback

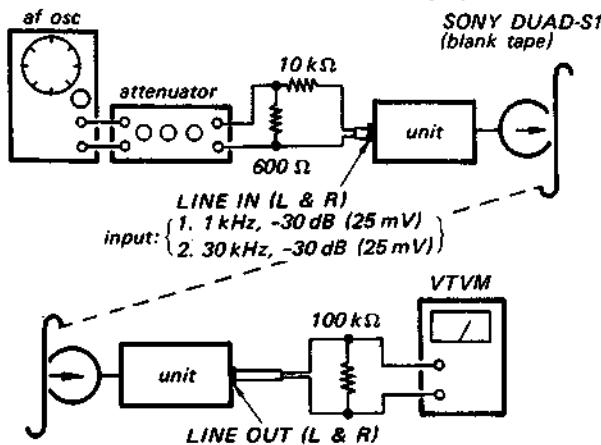

Adjust	Output	VTVM reading
L511 (L channel)	1 kHz	reference
L512 (R channel)	30 kHz	-1 dB (0.69 V)

**Adjustment Location:**

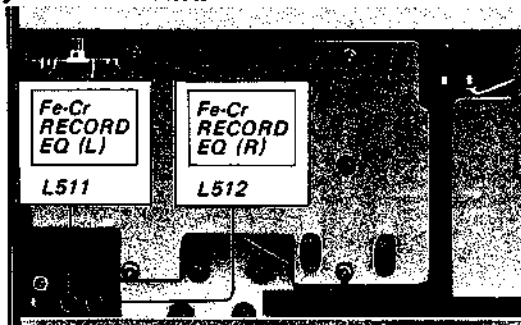

**17. Dummy Coil Adjustment**

**Settings:**

- REEL SIZE switch: 7
- TAPE SPEED switch: 19 cm, 7½
- BIAS (TAPE SELECT) switch: NORMAL
- EQ (TAPE SELECT) switch: NORMAL
- MONITOR switch: TAPE
- LINE IN control: mechanical mid
- PB LEVEL control: mechanical mid

**Procedure:**

Mode: record and simultaneous playback

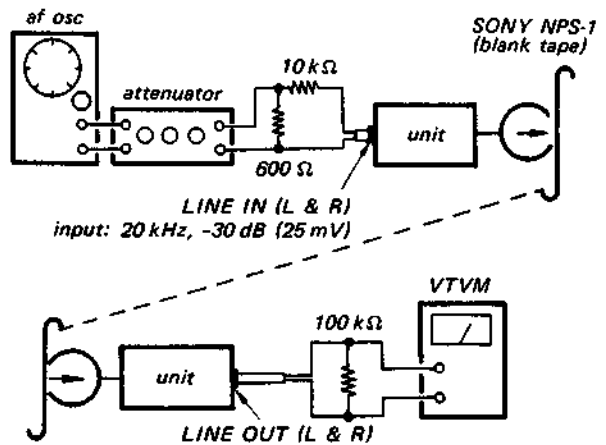

Step	Mode	Adjust	Remarks
1	stereo record and simultaneous playback	—	same VTVM reading
2	L channel record and simultaneous playback	L508	
3	R channel record and simultaneous playback	L507	

**Adjustment Location:**

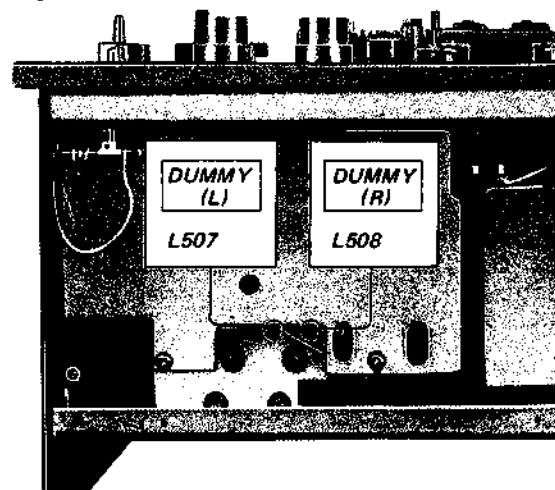





SECTION 3  
DIAGRAMS

3-1. SCHEMATIC DIAGRAM - AMP SECTION -

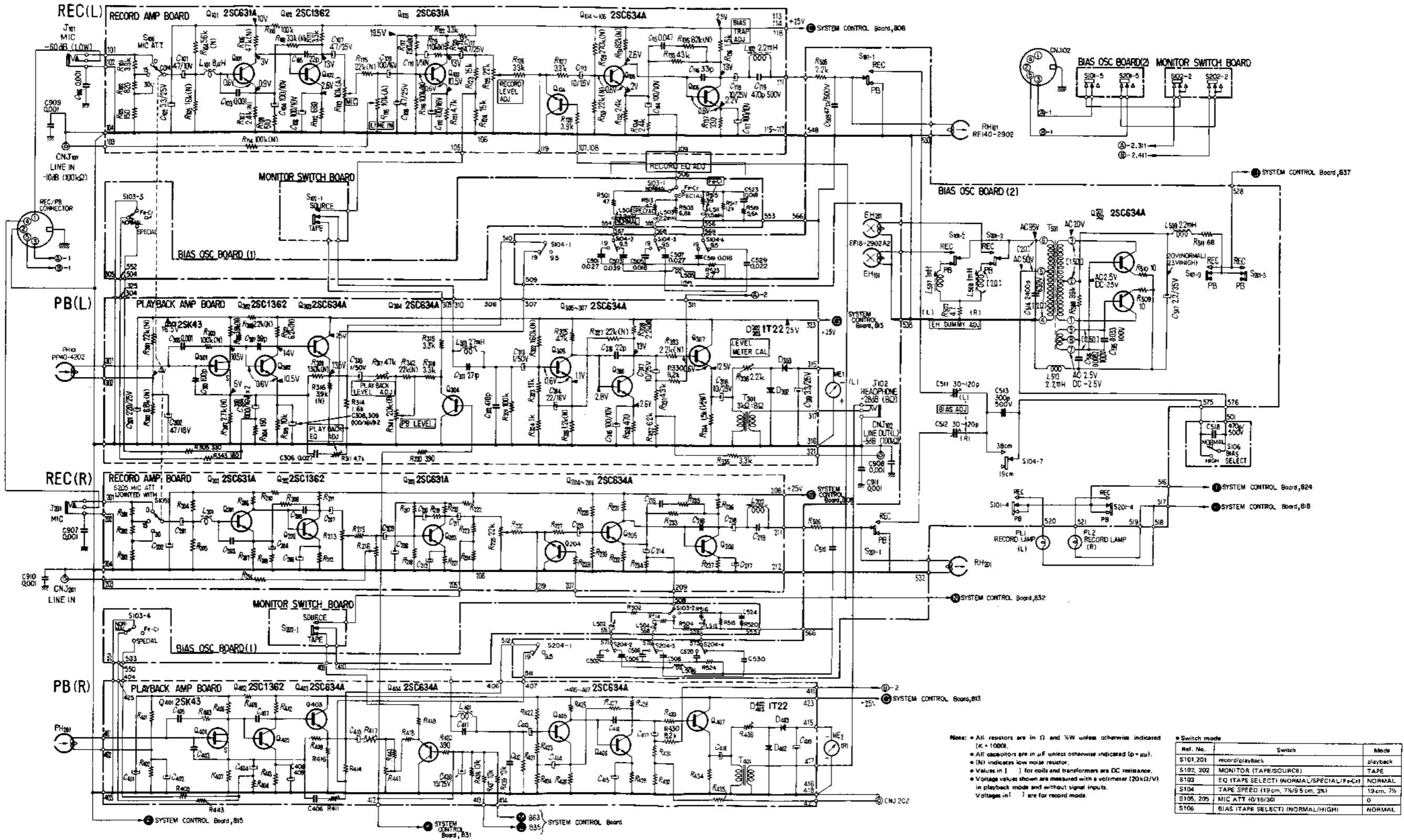

Note: • All resistors are in  $\Omega$  and  $\frac{1}{2}W$  unless otherwise indicated.  
 • All capacitors are in  $\mu F$  unless otherwise indicated ( $p = pF$ ).  
 • (NI) indicates low noise resistor.  
 • Values in [ ] for coils and transformers are DC resistance.  
 • Voltage values shown are measured with a voltmeter (20k $\Omega/V$ ) in playback mode and without signal inputs.  
 • Voltages in ( ) are for record mode.

• Switch mode

Ref. No.	Switch	Mode
S101, 201	record/playback	playback
S102, 202	MONITOR (TAPE/SOURCE)	TAPE
S103	EQ (TAPE SELECT) (NORMAL/SPECIAL/PE-CW)	NORMAL
S104	TAPE SPEED (19cm, 7 $\frac{1}{2}$ /9.5cm, 3 $\frac{1}{2}$ )	19cm, 7 $\frac{1}{2}$
S105, 205	MIC ATT (0/15/30)	0
S106	BIAS (TAPE SELECT) (NORMAL/HIGH)	NORMAL

3-2. MOUNTING DIAGRAM - AMP SECTION -

- Conductor Side -

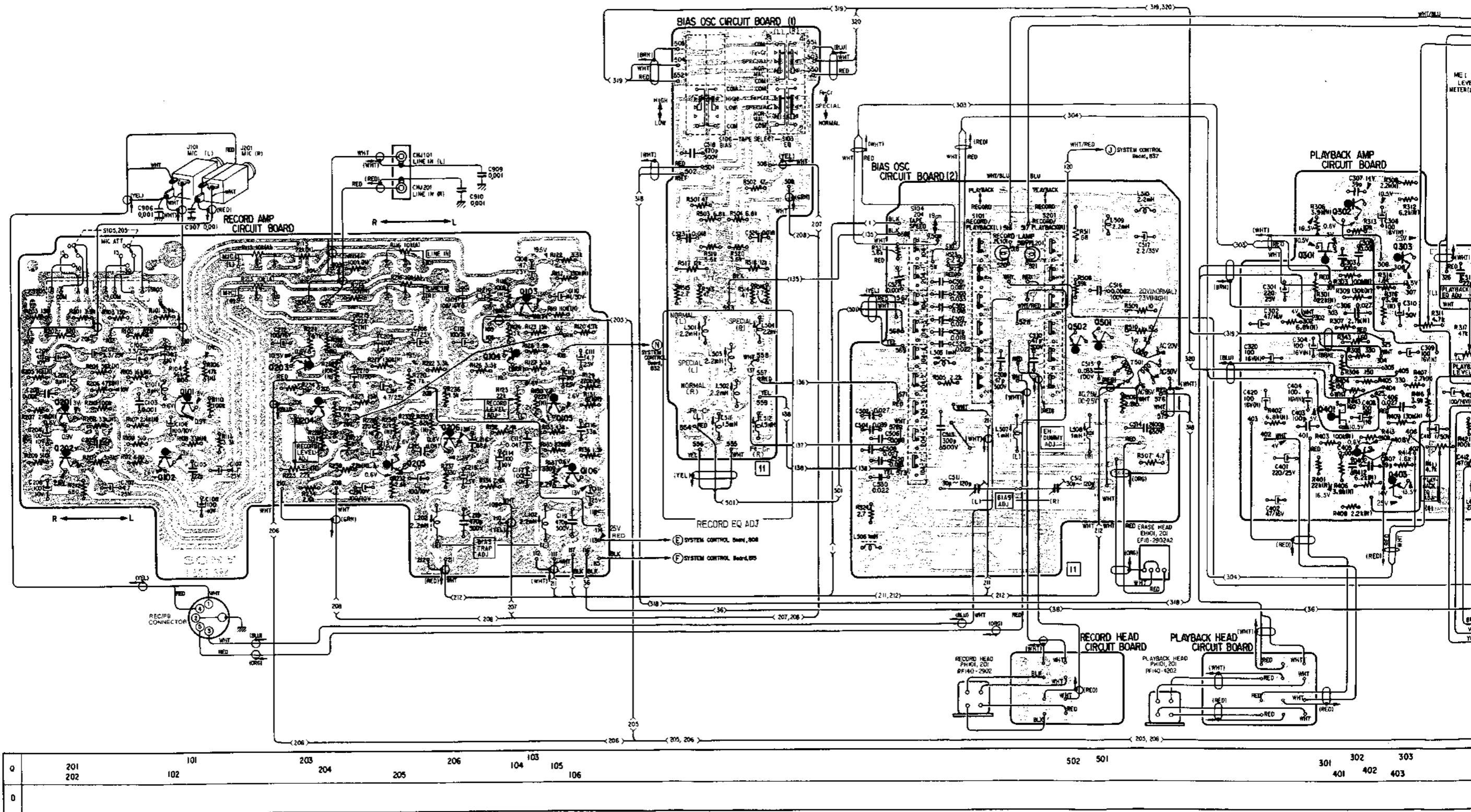

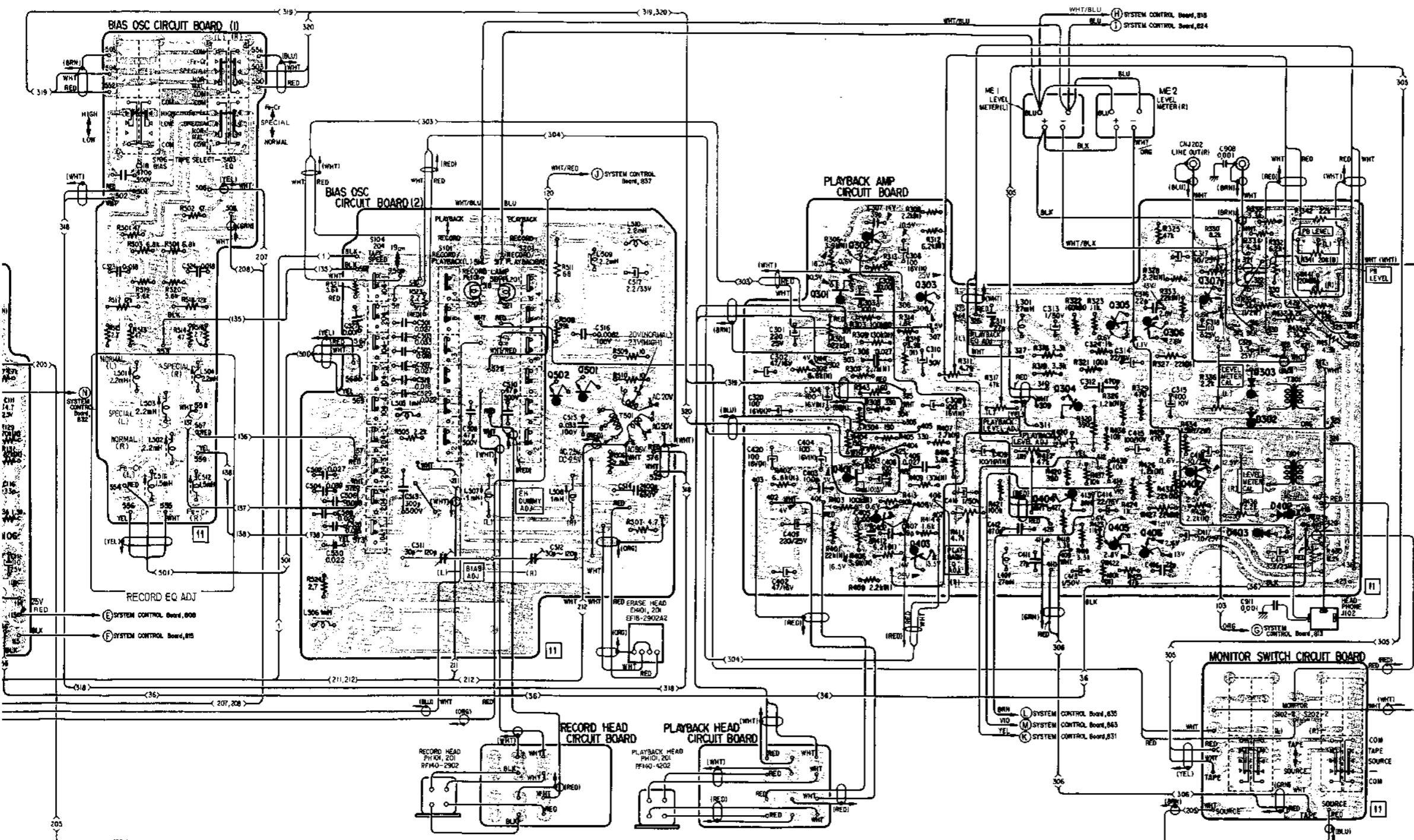

- 2SC631A: { Q101,103  
Q201,203
- 2SC634A: { Q104,105,106  
Q204,205,206  
Q303,304,305  
Q306,307  
Q403,404,405  
Q406,407  
Q501,502

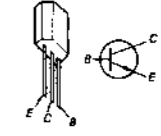

- 2SC1362: { Q102,202  
Q302,402

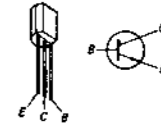

- ZSK43: Q301,401

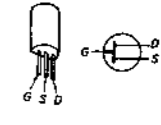

- 1T22: { D302,303  
D402,403

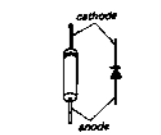

502	501	301	302	303	304	305	306	307	Q
		401	402	403	404	405	406	407	
									D

3.3. MOUNTING DIAGRAM - SYSTEM CONTROL SECTION -

TC-755A TC-

- Conductor Side -

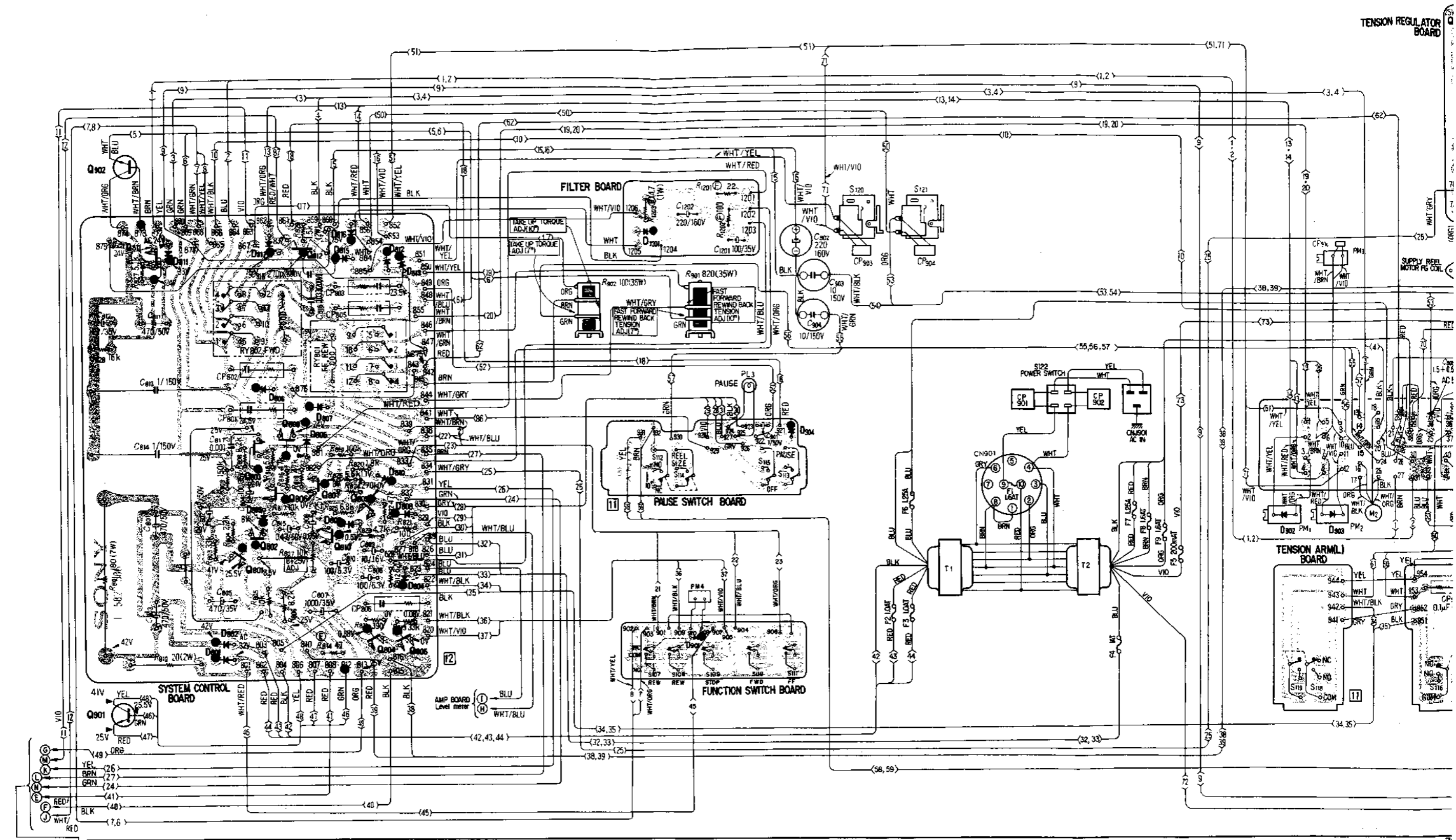

Q	902	808 812												
	811	803 806	807	809										
D	901	801 802	810 804	805										
	811	802 803	805 815	809										
		801	804	808										
					901		904				902	903		

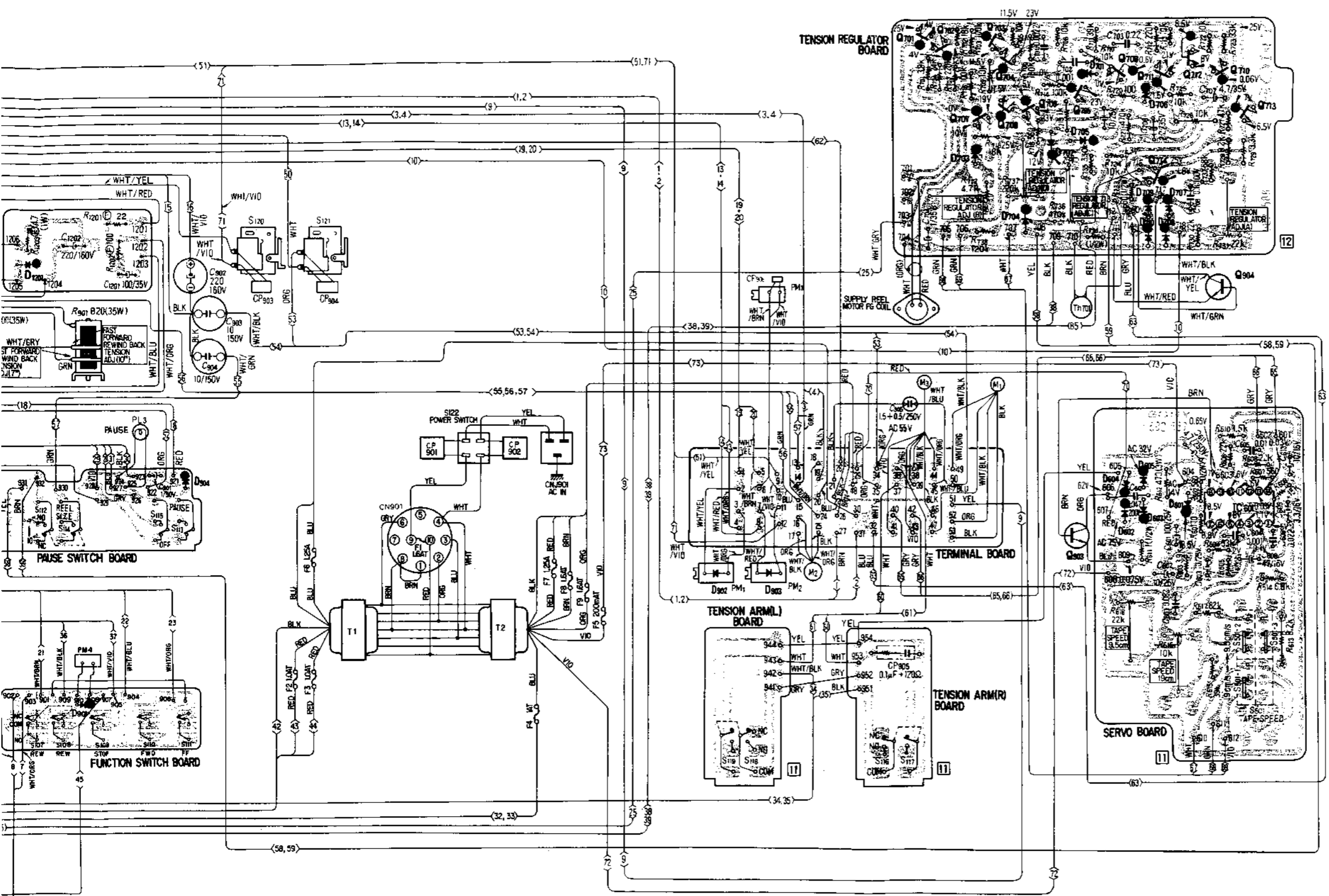

- 2SC634A: { Q701~713  
          Q801~811
- 10D-2: { D601~605  
         D707~710  
         D801,802,806,807  
         D811~813  
         D815,816  
         D901~903
- 10D-4: D817,904

- 2SC1384: Q714
- 1T40: { D701,702  
         D804,805,808
- 1T22: D809,810
- 1T22A: D705,706

- 2SC1124: Q812
- 2SC867: Q903,904
- 2SD291: Q801,902
- MZ12A: D704
- MZ08: D703,803

- CX032B: IC601
- S1B01-02: D1201

										601				IC
701	702	703				705	706	714	710					
		707	704	709	708			903		904				
				702	701		706	707						
							604	605	709	708				
							602	603	710	601				
1201	904													
901														

3-4. SCHEMATIC DIAGRAM - SYSTEM CONTROL SECTION -

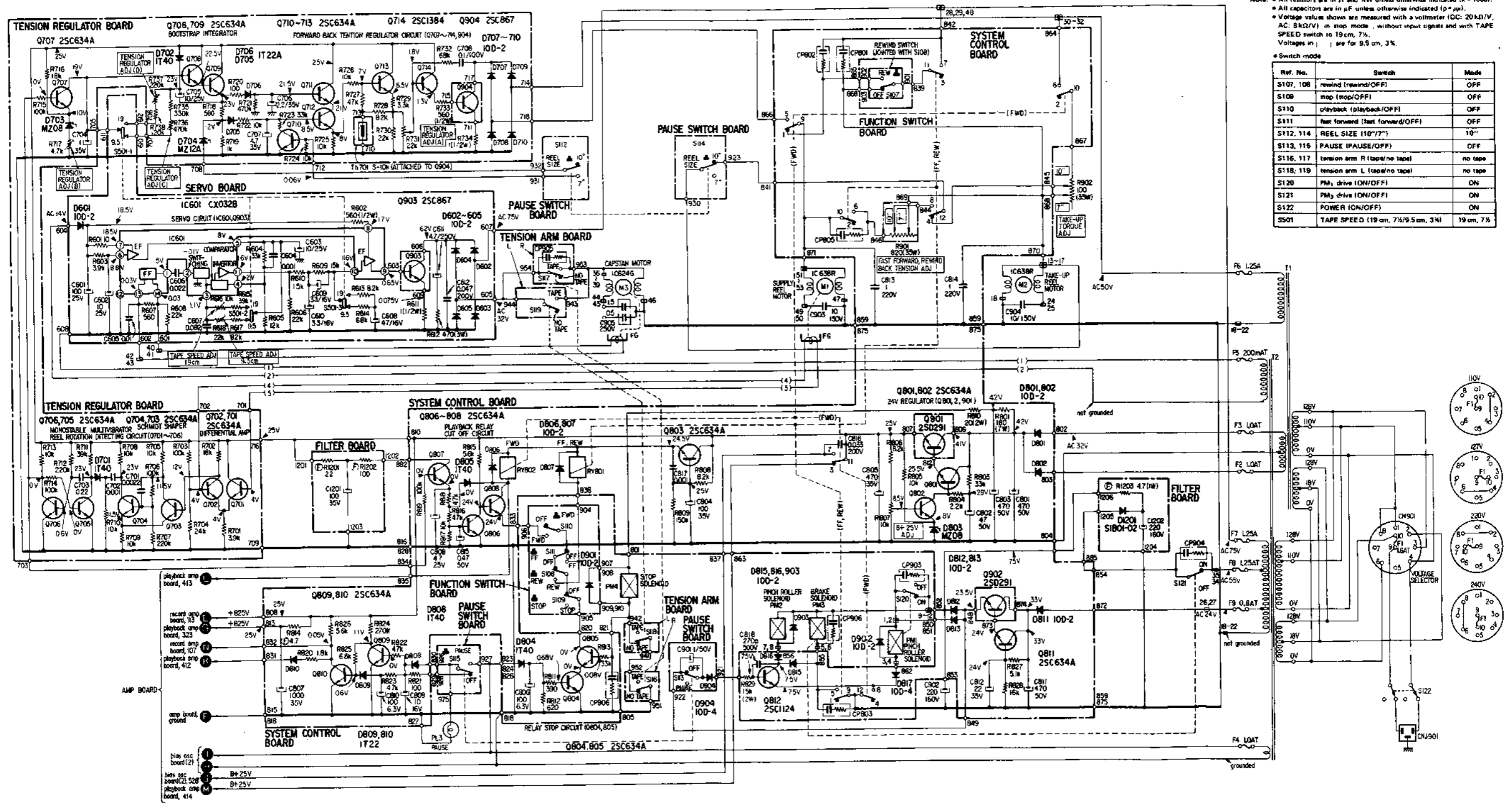

SECTION 4  
EXPLODED VIEWS AND PACKING

4.1. EXPLODED VIEW (1)

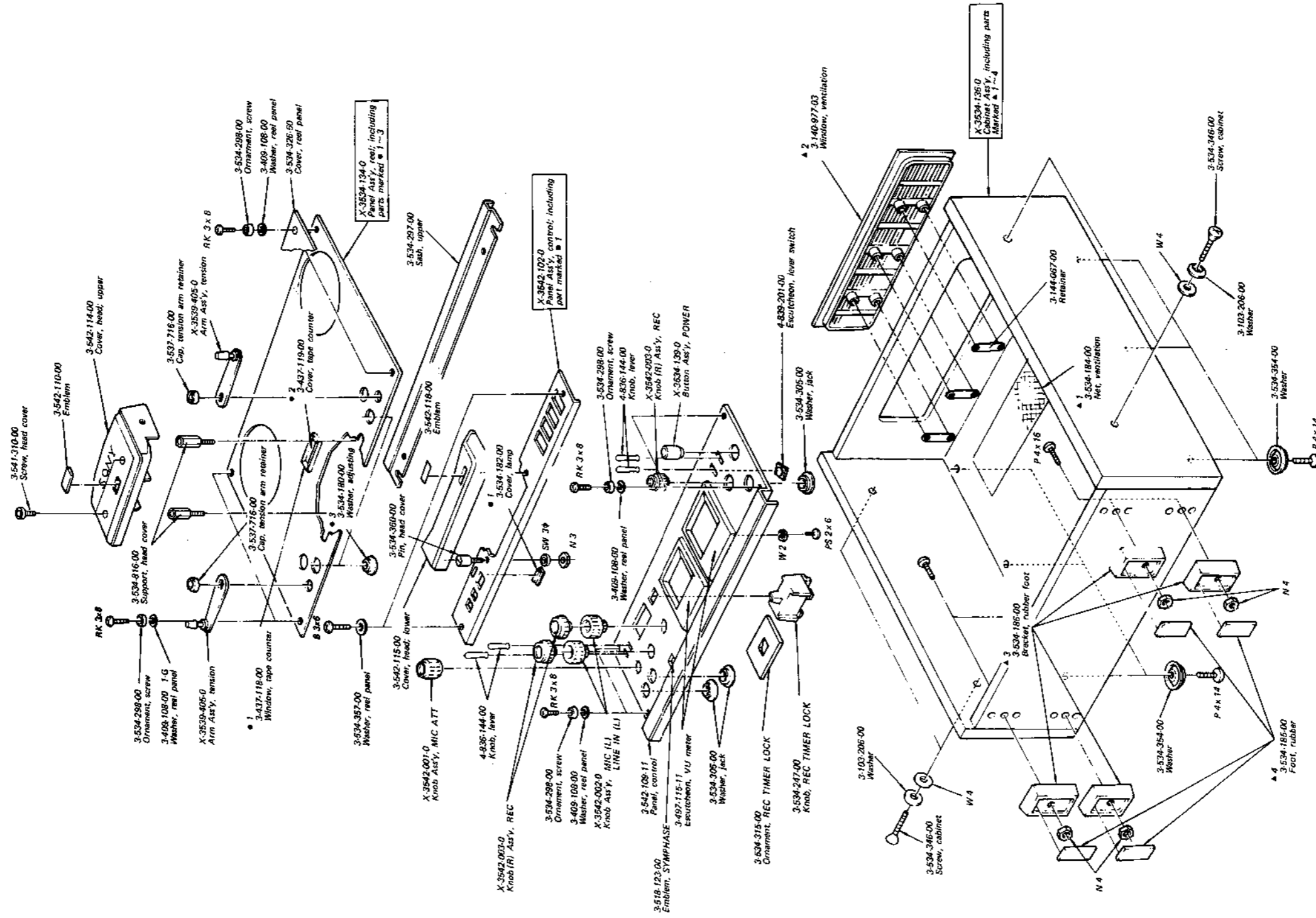

**Note:** 1. Parts without part numbers and names are not available.  
 2. All screws are Phillips type (cross recess type) unless otherwise indicated.  
 (-): slotted head



4-2. EXPLODED VIEW (2)

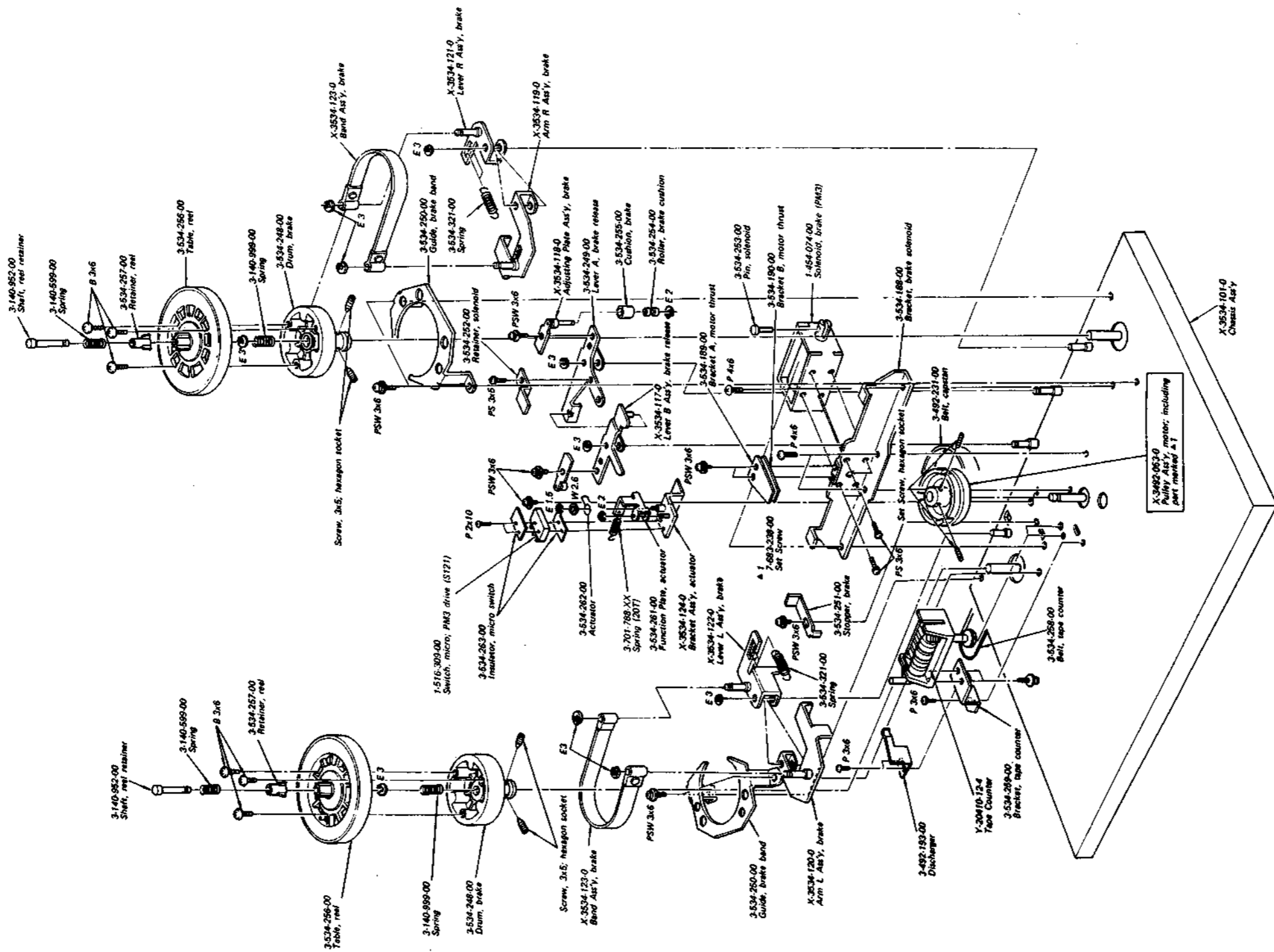

- Note:** 1. Parts without part numbers and names are not available.  
2. All screws are Phillips type (cross recess type) unless otherwise indicated.  
(-): slotted head

4-3. EXPLODED VIEW (3)

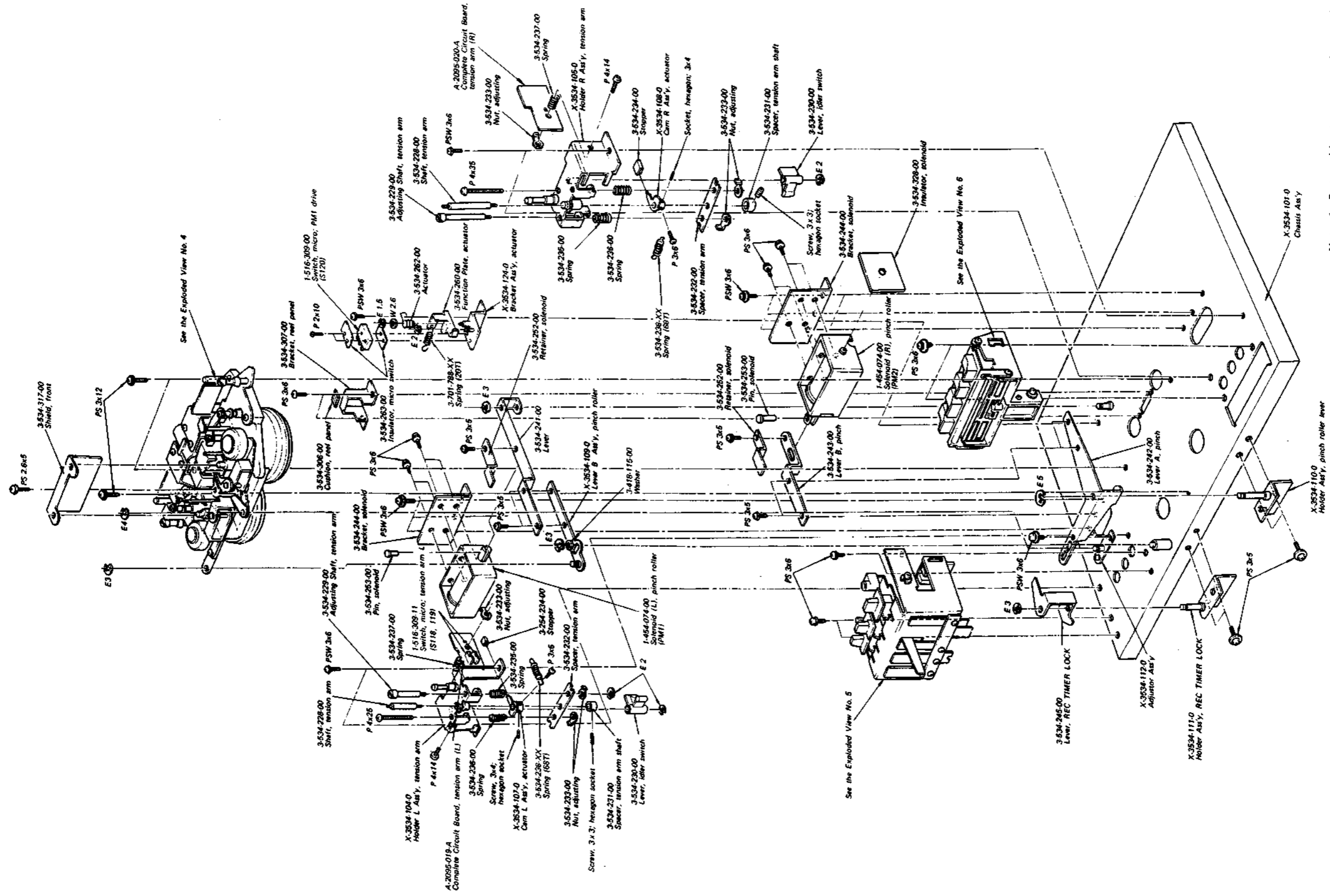

Note: 1. Parts without part numbers and names are not available.  
 2. All screws are Phillips type (cross recess type) unless otherwise indicated.  
 (-): slotted head

4. EXPLODED VIEW (4)

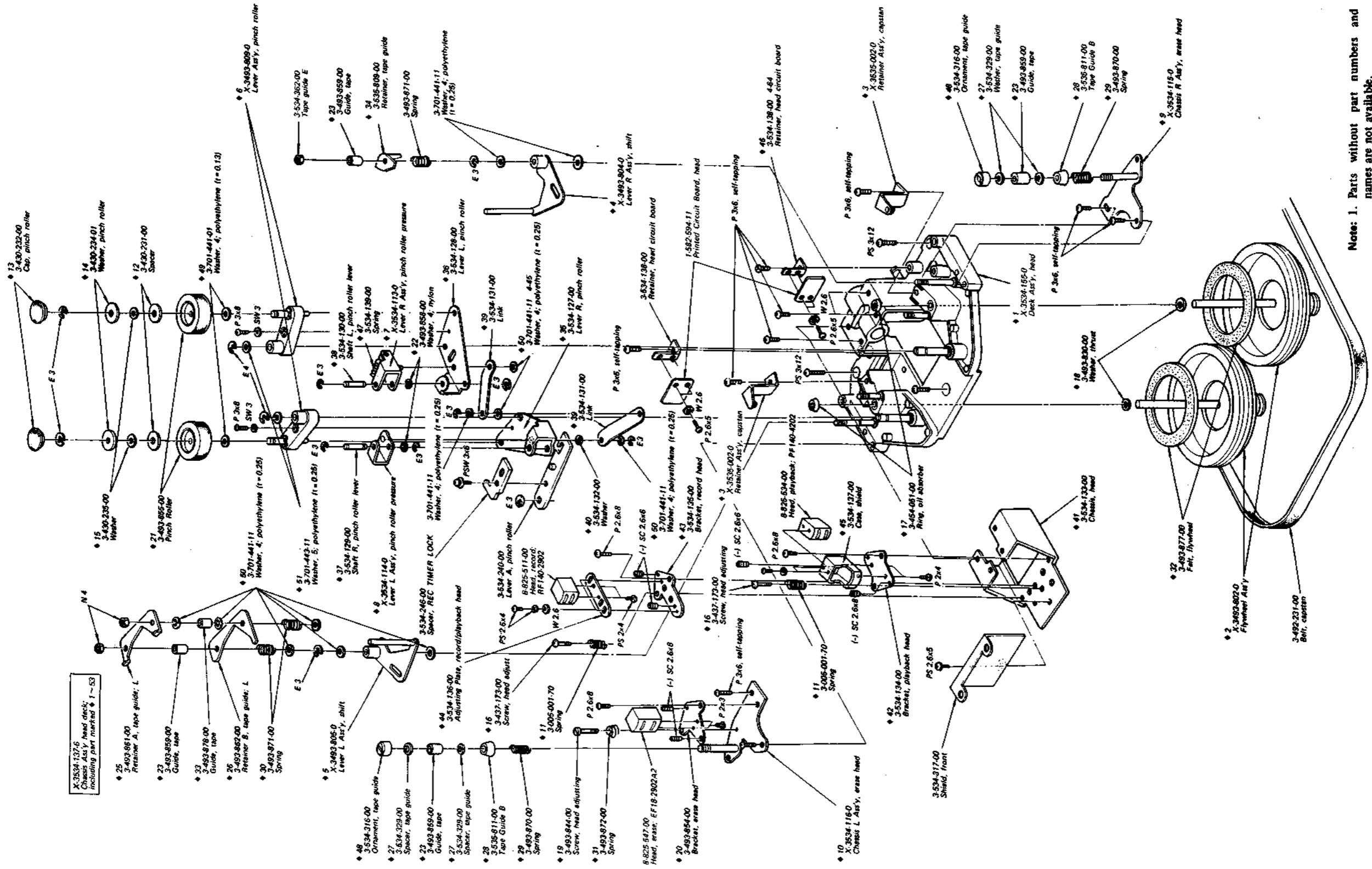

Note: 1. Parts without part numbers and names are not available.  
 2. All screws are Phillips type (cross recess type) unless otherwise indicated.  
 (-): slotted head

4-5. EXPLODED VIEW (5)

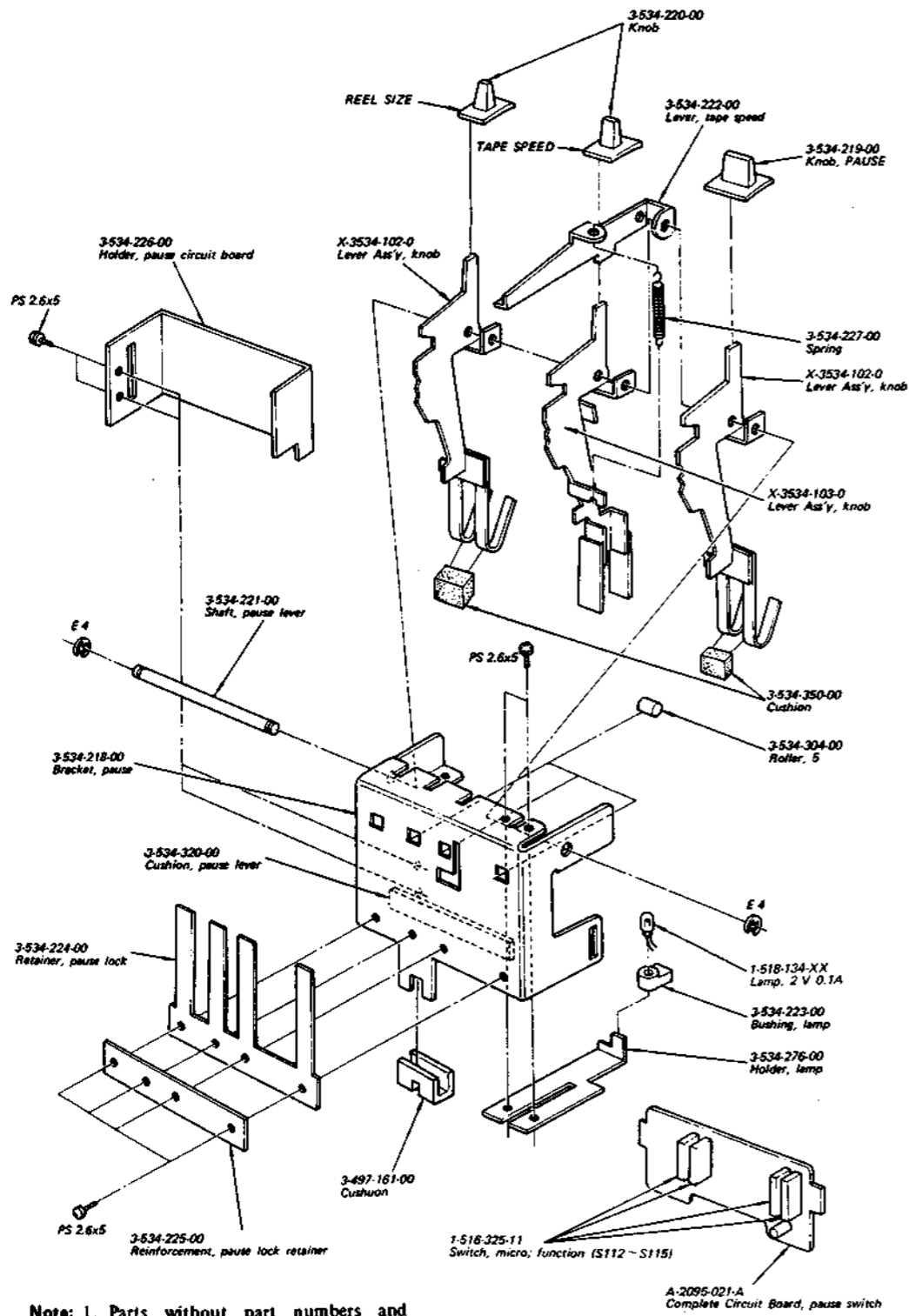

- Note: 1. Parts without part numbers and names are not available.  
 2. All screws are Phillips type (cross recess type) unless otherwise indicated.  
 (-): slotted head

4-6. EXPLODED VIEW (6)

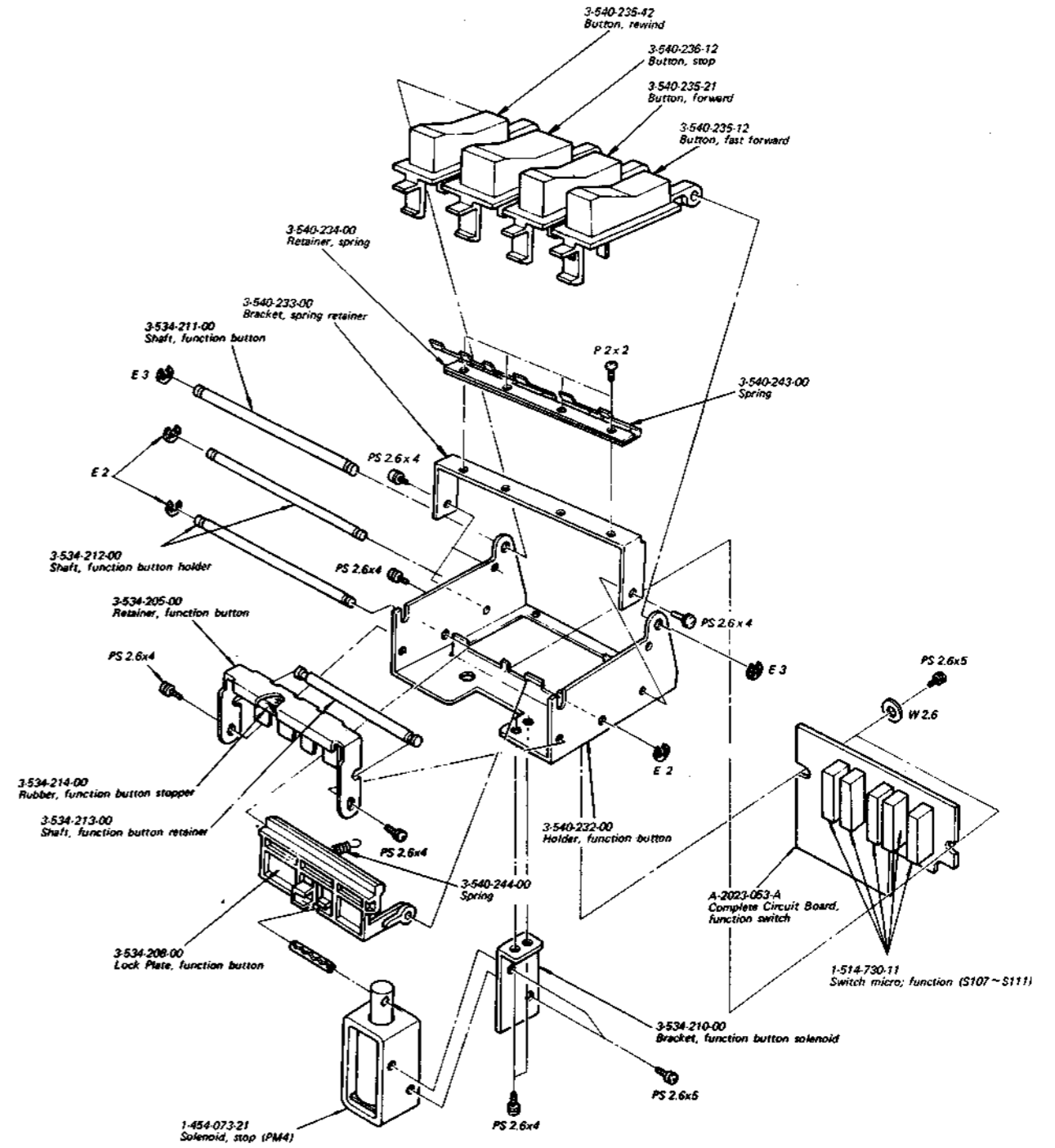

- Note: 1. Parts without part numbers and names are not available.  
 2. All screws are Phillips type (cross recess type) unless otherwise indicated.  
 (-): slotted head

4-7. EXPLODED VIEW (7)

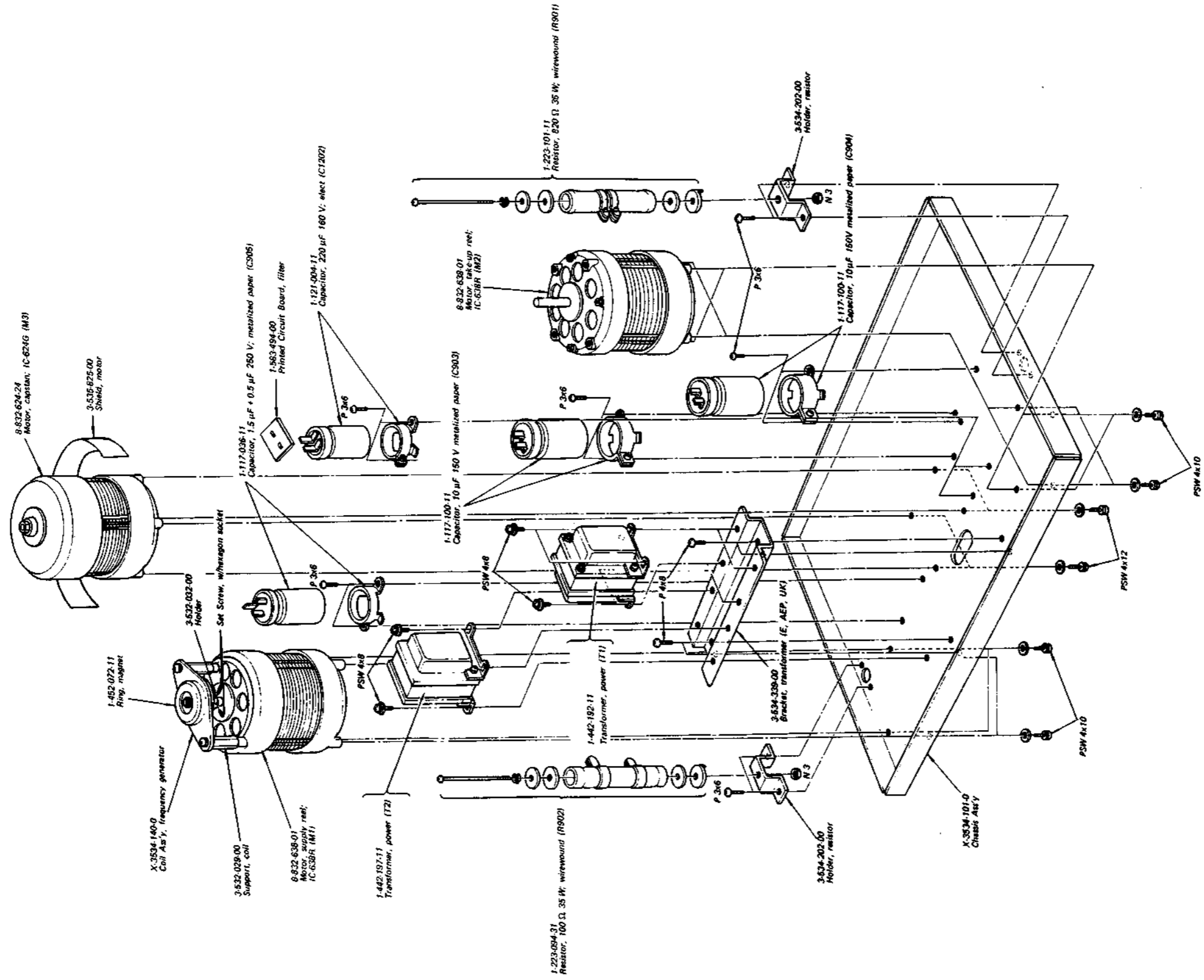

- Note: 1. Parts without part numbers and names are not available.  
 2. All screws are Phillips type (cross recess type) unless otherwise indicated.  
 (-): slotted head



4-9. EXPLODED VIEW (9)

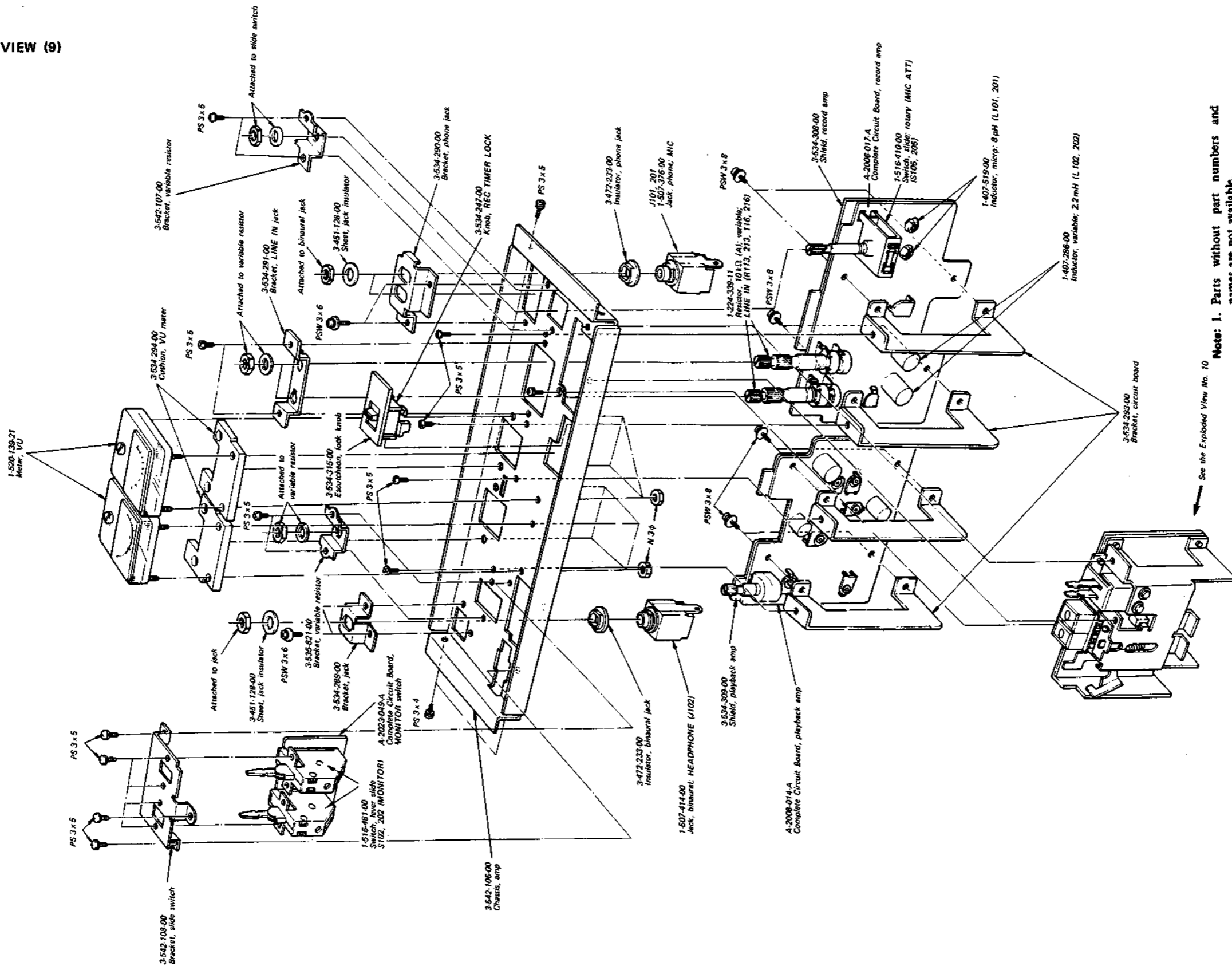

Note: 1. Parts without part numbers and names are not available.  
 2. All screws are Phillips type (cross recess type) unless otherwise indicated.  
 (-): slotted head

4-10. EXPLODED VIEW (10)

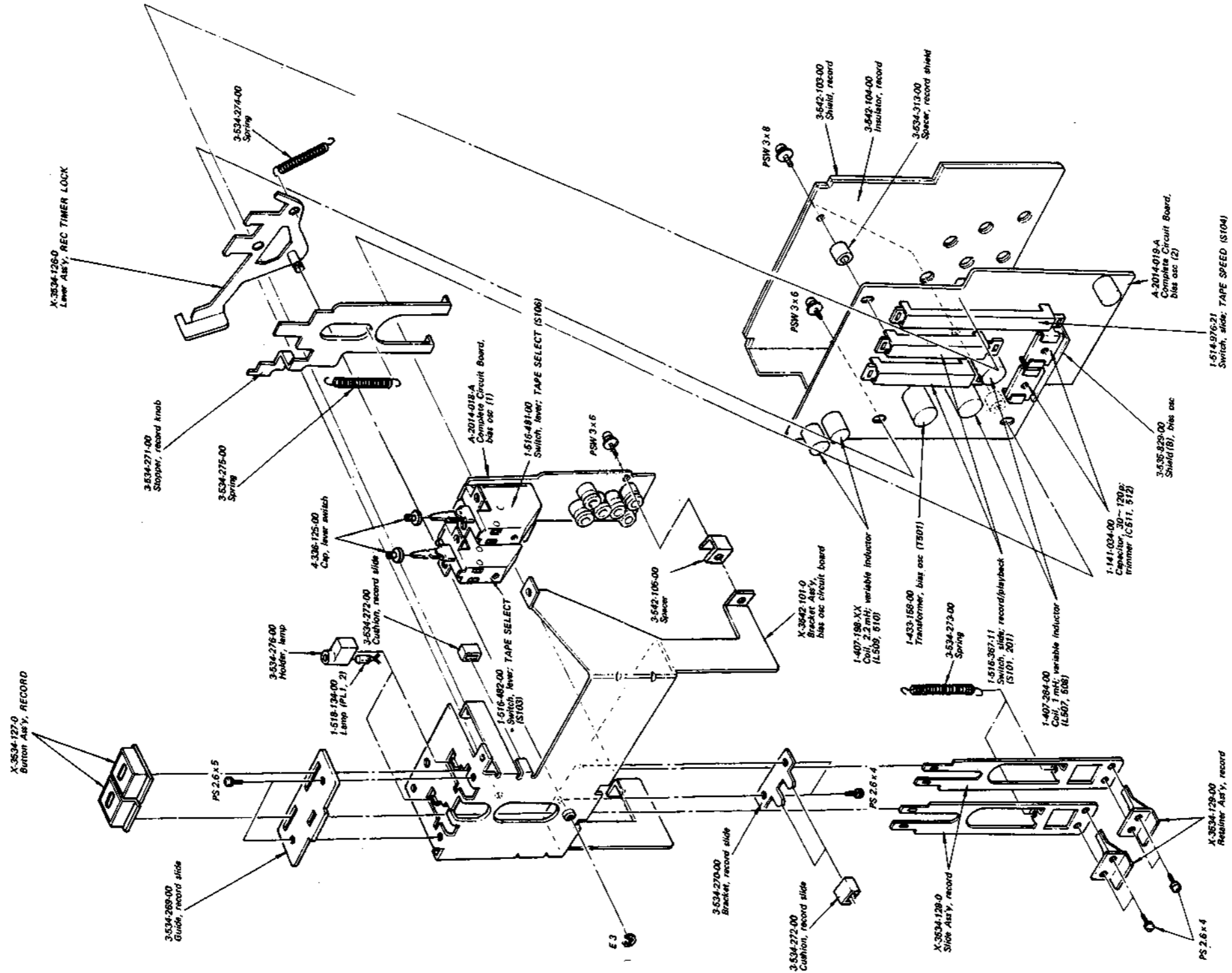

Note: 1. Parts without part numbers and names are not available.  
 2. All screws are Phillips type (cross recess type) unless otherwise indicated.  
 (-): slotted head



**SECTION 5  
ELECTRICAL PARTS LIST**

<u>Ref. No.</u>	<u>Part No.</u>	<u>Description</u>	<u>Ref. No.</u>	<u>Part No.</u>	<u>Description</u>
<b>COMPLETE CIRCUIT BOARDS</b>			Q701	2SC634A	
	A-2095-020-A	Tension Arm (R)	Q702	2SC634A	
	A-2095-019-A	Tension Arm (L)	Q703	2SC634A	
	A-2019-023-A	System Control	Q704	2SC634A	
	A-2020-003-A	Servo	Q705	2SC634A	
	A-2095-022-A	Tension Regulator	Q706	2SC634A	
	A-2023-053-A	Function Switch	Q707	2SC634A	
	A-2095-021-A	Pause Switch	Q708	2SC634A	
	A-2006-017-A	Record Amp	Q709	2SC634A	
	A-2008-014-A	Playback Amp	Q710	2SC634A	
	A-2023-049-A	MONITOR Switch	Q711	2SC634A	
	A-2014-018-A	Bias osc (1)	Q712	2SC634A	
	A-2014-019-A	Bias osc (2)	Q713	2SC634A	
			Q714	2SC1384	
			Q801	2SC634A	
			Q802	2SC634A	
			Q803	2SC634A	
			Q804	2SC634A	
			Q805	2SC634A	
			Q806	2SC634A	
			Q807	2SC634A	
			Q808	2SC634A	
			Q809	2SC634A	
			Q810	2SC634A	
			Q811	2SC634A	
			Q812	2SC1124	
			Q901	2SD291	
			Q902	2SD291	
			Q903	2SC867	
			Q904	2SC867	
					<b>IC</b>
			IC601	CX032B	
					<b>Diodes</b>
			D302,402	1T22	
			D303,403	1T22	
Q101,201	2SC631A				
Q102,202	2SC1362				
Q103,203	2SC631A				
Q104,204	2SC634A				
Q105,205	2SC634A				
Q106,206	2SC634A				
Q301,401	2SK43				
Q302,402	2SC1362				
Q303,403	2SC634A				
Q304,404	2SC634A				
Q305,405	2SC634A				
Q306,406	2SC634A				
Q307,407	2SC634A				
Q501	2SC634A				
Q502	2SC634A				

<u>Ref. No.</u>	<u>Part No.</u>	<u>Description</u>
D601	10D-2	
D602	10D-2	
D603	10D-2	
D604	10D-2	
D605	10D-2	
D701	1T40	
D702	1T40	
D703,803	MZ08	
D704	MZ12A	
D705	1T22A	
D706	1T22A	
D707	10D-2	
D708	10D-2	
D709	10D-2	
D710	10D-2	
D801	10D-2	
D802	10D-2	
D804	1T40	
D805	1T40	
D806	10D-2	
D807	10D-2	
D808	1T40	
D809	1T22	
D810	1T22	
D811	10D-2	
D812	10D-2	
D813	10D-2	
D815	10D-2	
D816	10D-2	
D817	10D-4	
D901	10D-2	
D902	10D-2	
D903	10D-2	
D904	10D-4	
D1201	S1B01-02	
<b>THERMISTOR</b>		
Th701	1-800-204-11	Thermistor S10K

<u>Ref. No.</u>	<u>Part No.</u>	<u>Description</u>
<b>COILS</b>		
L101,201	1-407-519-11	Inductor, micro 8 $\mu$ H
L102,202	1-407-286-11	Inductor, variable 2.2 mH
L301,401	1-407-593-11	Microinductor, 27 mH
L501	1-407-269-11	Inductor, variable 2.2 mH
L502	1-407-269-11	Inductor, variable 2.2 mH
L503	1-407-269-11	Inductor, variable 2.2 mH
L504	1-407-269-11	Inductor, variable 2.2 mH
L505	1-407-492-11	Inductor, micro 1 mH
L506	1-407-492-11	Inductor, micro 1 mH
L507	1-407-284-11	Inductor, variable 1 mH
L508	1-407-284-11	Inductor, variable 1 mH
L509	1-407-198-XX	Inductor, micro 2.2 mH
L510	1-407-198-XX	Inductor, micro 2.2 mH
L511	1-407-268-11	Inductor, variable 1.5 mH
L512	1-407-268-11	Inductor, variable 1.5 mH
<b>TRANSFORMERS</b>		
T1	1-442-192-11	Power
T2	1-442-197-11	Power
T301,401	1-427-299-11	Headphone
T501	1-433-158-11	Bias Osc
<b>CAPACITORS</b>		
All capacitors are in $\mu$ F unless otherwise noted. 50 or less working volts are omitted except for electrolytic type. (p= $\mu$ F, elect=electrolytic)		
C101,201	1-131-192-11	4.7 solid tantalum
C102,202	1-121-913-11	3.3 25 V elect
C103,203	1-108-825-61	0.001 mylar
C104,204	1-121-414-51	100 10 V elect
C105,205	1-102-967-11	22 p ceramic
C106,206	1-121-414-51	100 10 V elect
C107,207	1-121-915-51	4.7 25 V elect
C108,208	1-121-410-51	47 25 V elect

<u>Ref. No.</u>	<u>Part No.</u>	<u>Description</u>		<u>Ref. No.</u>	<u>Part No.</u>	<u>Description</u>	
C109,209	1-121-415-51	100	16 V elect	C511	1-141-034-11	30~120 p	trimmer
C110,210	1-121-391-51	1	50 V elect	C512	1-141-034-11	30~120 p	trimmer
C111,211	1-121-915-51	4.7	25 V elect	C513	1-107-180-11	300 p	silvered mica
C112,212	1-121-415-51	100	16 V elect	C514	1-129-992-51	2400 p 630 V	polypropylene
C113,213	1-121-748-51	10	25 V elect	C515	1-105-719-12	0.033 100 V	mylar
C114,214	1-121-414-51	100	10 V elect	C516	1-105-712-12	0.0082 100 V	mylar
C115,215	1-105-681-51	0.047	mylar	C517	1-131-217-51	2.2	solid tantalum
C116,216	1-107-119-51	33 p	silvered mica	C518	1-107-185-11	470 p 500 V	silvered mica
C117,217	1-121-414-51	100	10 V elect	C519	1-105-516-12	0.018	mylar
C118,218	1-121-398-51	10	25 V elect	C520	1-105-516-12	0.018	mylar
C119,219	1-107-016-11	470 p	500 V silvered mica	C523	1-105-516-12	0.018	mylar
C301,401	1-121-422-51	220	25 V elect	C524	1-105-516-12	0.018	mylar
C302,402	1-123-055-51	47	16 V elect	C529	1-105-517-12	0.022	mylar
C303,403	1-107-131-51	100 p	silvered mica	C530	1-105-517-12	0.022	mylar
C304,404	1-123-139-51	100	16 V elect	C601	1-121-935-51	100 25 V	elect
C305,405	1-108-825-61	0.001	mylar	C602	1-121-398-51	10 25 V	elect
C306,406	1-108-842-61	0.027	mylar	C603	1-121-398-51	10 25 V	elect
C307,407	1-107-121-51	39 p	silvered mica	C604	1-105-661-51	0.001	mylar
C308,408	1-123-139-51	100	16 V elect	C605	1-105-673-51	0.01	mylar
C309,409	1-123-139-51	100	16 V elect	C606	1-105-677-51	0.022	mylar
C310,410	1-121-912-51	1	50 V elect	C607	1-108-550-11	0.082	mylar
C311,411	1-107-117-51	27 p	silvered mica	C608	1-121-409-51	47 16 V	elect
C312,412	1-107-244-51	470 p	silvered mica	C609	1-131-197-51	3.3	solid tantalum
C313,413	1-121-912-51	1	50 V elect	C610	1-131-197-51	3.3	solid tantalum
C314,414	1-121-479-51	22	16 V elect	C611	1-121-900-11	4.7 250 V	elect
C315,415	1-121-414-51	100	10 V elect	C612	1-105-761-12	0.047 200 V	mylar
C316,416	1-107-115-51	22 p	silvered mica	C701	1-105-665-51	0.0022	mylar
C317,417	1-121-398-51	10	25 V elect	C702	1-105-501-12	0.001	mylar
C318,418	1-121-398-51	10	25 V elect	C703	1-105-529-12	0.22	mylar
C319,419	1-121-392-51	3.3	25 V elect	C704	1-131-215-51	1	solid tantalum
C320,420	1-123-139-51	100	16 V elect	C705	1-131-238-51	10	solid tantalum
C501	1-105-518-12	0.027	mylar	C706	1-131-217-51	2.2	solid tantalum
C502	1-105-518-12	0.027	mylar	C707	1-131-219-51	4.7	solid tantalum
C503	1-105-520-12	0.039	mylar	C708	1-105-725-51	0.1 100 V	mylar
C504	1-105-520-12	0.039	mylar	C801	1-121-983-51	470 50 V	elect
C505	1-105-516-12	0.018	mylar	C802	1-121-411-51	47 50 V	elect
C506	1-105-516-12	0.018	mylar	C803	1-121-810-51	470 50 V	elect
C507	1-105-518-12	0.027	mylar	C804	1-121-357-51	100 35 V	elect
C508	1-105-518-12	0.027	mylar	C805	1-121-361-51	470 35 V	elect
C509	1-107-015-11	47 p	500 V silvered mica	C806	1-121-980-11	100 6.3 V	elect
C510	1-107-015-11	47 p	500 V silvered mica				

<u>Ref. No.</u>	<u>Part No.</u>	<u>Description</u>		<u>Ref. No.</u>	<u>Part No.</u>	<u>Description</u>	
C807	1-121-388-51	1000	35 V elect	R116,216	1-224-339-11	10 k (A), variable;	LINE IN
C808	1-121-961-11	4.7	25 V elect	R117,217	1-242-724-71	130 k	low noise
C809	1-121-651-51	10	16 V elect	R118,218	1-242-721-71	100 k	low noise
C810	1-121-980-11	100	6.3 V elect	R119,219	1-242-722-71	110 k	low noise
C811	1-121-983-51	470	50 V elect	R125,225	1-222-775-11	22 k (B), adjustable	
C812	1-121-662-51	22	35 V elect	R129,229	1-242-731-71	270 k	low noise
C813	1-113-072-11	1	220 V metalized paper	R130,230	1-242-705-71	22 k	low noise
C814	1-113-072-11	1	220 V metalized paper	R131,231	1-242-719-71	82 k	low noise
C815	1-121-726-51	0.47	50 V elect	R135,235	1-242-719-71	82 k	low noise
C816	1-105-919-12	0.033	200 V mylar	R301,401	1-242-705-71	22 k	low noise
C817	1-105-821-12	0.001	mylar	R302,402	1-242-693-71	6.8 k	low noise
C818	1-107-179-11	270 p	500 V silvered mica	R303,403	1-242-721-71	100 k	low noise
C901	1-121-391-11	1	50 V elect	R306,406	1-242-687-71	3.9 k	low noise
C902	1-121-004-12	220	160 V elect	R307,407	1-242-683-71	2.7 k	low noise
C903	1-117-100-11	10	150 V metalized paper	R308,408	1-242-681-71	2.2 k	low noise
C904	1-117-100-11	10	150 V metalized paper	R309,409	1-242-724-71	130 k	low noise
C905	1-117-036-22	1.5+0.5	250 V metalized paper	R311,411	1-224-644-XX	4.7 k (B), adjustable	
C906	1-101-455-11	0.001	ceramic	R312,412	1-242-692-71	6.2 k	low noise
C907	1-101-455-11	0.001	ceramic	R316,416	1-242-687-71	3.9 k	low noise
C908	1-101-455-11	0.001	ceramic	R317,417	1-224-647-XX	47 k (B), adjustable	
C909	1-101-455-11	0.001	ceramic	R322,422	1-242-726-71	160 k	low noise
C910	1-101-455-11	0.001	ceramic	R326,426	1-242-675-71	1.2 k	low noise
C911	1-101-455-11	0.001	ceramic	R327,427	1-242-705-71	22 k	low noise
C1201	1-121-357-11	100	35 V elect	R328,428	1-242-681-71	2.2 k	low noise
C1202	1-121-004-11	220	160 V elect	R333,433	1-242-705-71	22 k	low noise
				R334,434	1-244-877-11	1.5 k	½ W
				R336,436	1-224-643-XX	2.2 k (B), adjustable	
				R341,441	1-224-338-11	20 k (B), variable; PB LEVEL	
				R342	1-244-705-71	22 k	low noise
				R442	1-242-705-71	22 k	low noise
				R511	1-217-397-11	68	fuse
				R602	1-244-867-11	560	½ W
				R611	1-244-801-11	1	½ W
				R612	1-206-717-11	470	3 W metal oxide
				R616	1-224-645-XX	10 k (B), adjustable	
				R618	1-224-646-XX	22 k (B), adjustable	
				R717	1-224-644-XX	4.7 k (B), adjustable	
				R731	1-224-646-XX	22 k (B), adjustable	
				R733	1-244-867-11	560	½ W
				R734	1-244-801-11	1	½ W
				R736	1-224-650-XX	470 k (B), adjustable	

### RESISTORS

All resistors are in  $\Omega$ . ½ W,  $\pm 5\%$  carbon resistors (except particular type) are omitted.

Check schematic diagrams for resistance values.  
(k = 1000 M = 1000k)

R104,204	1-242-715-71	56 k	low noise
R105,205	1-242-702-71	16 k	low noise
R106,206	1-242-713-71	47 k	low noise
R107,207	1-242-682-71	2.4 k	low noise
R108,208	1-242-709-71	33 k	low noise
R113,213	1-224-339-11	10 k(A), variable;	MIC
R114,214	1-242-721-71	100 k	low noise
R115,215	1-242-705-71	22 k	low noise

<u>Ref. No.</u>	<u>Part No.</u>	<u>Description</u>
R737	1-222-778-11	220 k (B), adjustable
R801	1-207-992-11	180 7 W wirewound
R807	1-224-645-XX	10 k (B), adjustable
R810	1-206-470-11	20 2 W metal oxide
R814	1-217-383-11	4.7 fuse
R829	1-244-877-11	1.5 k ½ W
R901	1-223-101-11	820, wirewound; adjustable
R902	1-223-094-31	100, wirewound; adjustable
R1201	1-217-391-11	22 fuse
R1202	1-217-399-11	100 fuse
R1203	1-217-477-11	4.7 1 W fuse

**SWITCHES**

S101,201	1-516-367-11	Slide, record/playback
S102,202	1-516-481-11	Slide, MONITOR
S103	1-516-482-11	Slide, EQ (TAPE SELECT)
S104	1-514-976-21	Slide, TAPE SPEED
S105,205	1-516-410-11	Rotary Slide, MIC ATT
S106	1-516-481-11	Micro, BIAS (TAPE SELECT)
S107	1-514-730-11	Micro, rewind
S108	1-514-730-11	Micro, rewind
S109	1-514-730-11	Micro, stop
S110	1-514-730-11	Micro, playback
S111	1-514-730-11	Micro, fast forward
S112,114	1-516-325-11	Micro, REEL SIZE
S113,115	1-516-325-11	Micro, PAUSE
S116	1-516-309-11	Micro, tension arm R
S117	1-516-309-11	Micro, tension arm R
S118	1-516-309-11	Micro, tension arm L
S119	1-516-309-11	Micro, tension arm L
S120	1-516-309-11	Micro, PM1 drive
S121	1-516-309-11	Micro, PM3 drive
S122	1-516-277-11	Push, POWER
S501	1-514-673-11	Slide, TAPE SPEED

**ENCAPSULATED COMPONENTS**

CP801	1-231-057-31
CP802	1-231-057-31

<u>Ref. No.</u>	<u>Part No.</u>	<u>Description</u>
CP803	1-231-057-31	
CP805	1-231-057-31	
CP806	1-231-057-31	
CP903	1-101-534-31	
CP904	1-101-534-31	
CP905	1-101-534-31	
CP906	1-101-534-31	

**JACKS**

J101,201	1-507-376-11	Phono, MIC
J102	1-507-414-11	Binaural, HEADPHONE
	1-509-359-11	Connector, REC/PB
CNJ901	1-509-546-00	Connector, AC IN
CN901	1-509-482-11	Socket, voltage selector
CNJ101,201	1-507-349-21	2 p phono, LINE IN
CNJ102,202	1-507-349-21	2 p phono, LINE OUT









**MISCELLANEOUS**

EH101,201	8-825-547-00	Head, erase; EF18-2902A2
F1	1-532-259-00	Fuse, 1.6 AT
F2	1-532-078-11	Fuse, 1 AT
F3	1-532-078-11	Fuse, 1 AT
F4	1-532-078-11	Fuse, 1 AT
F5	1-532-074-11	Fuse, 200 mAT
F6	1-532-296-11	Fuse, 1.25 AT
F7	1-532-296-11	Fuse, 1.25 AT
F8	1-532-285-11	Fuse, 1.25 AT
F9	1-532-215-11	Fuse, 800 mAT
M1	8-832-638-01	Motor, supply reel; IC-638R
M2	8-832-638-01	Motor, take-up reel; IC-638R
M3	8-832-624-24	Motor, capstan; IC-624G
PH101,201	8-825-534-00	Head, playback; PF140-4202
ME1,2	1-520-139-21	Meter, VU

<u>Ref. No.</u>	<u>Part No.</u>	<u>Description</u>
PL1	1-518-134-XX	Lamp, 2 V 0.1 A
PL2	1-518-134-XX	Lamp, 2 V 0.1 A
PL3	1-518-134-XX	Lamp, 2 V 0.1 A
PM1	1-454-074-00	Solenoid (L), pinch roller
PM2	1-454-074-00	Solenoid (R), pinch roller
PM3	1-454-074-00	Solenoid, brake
PM4	1-454-073-21	Solenoid, stop
RH101,201	8-825-511-00	Head, record; RF140-2902
RY801	1-515-127-XX	Relay
RY802	1-515-127-XX	Relay
	1-452-072-11	Ring, magnet
	1-533-105-12	Holder, fuse; 4 p
	1-536-395-11	Strip, terminal; 1L1

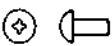
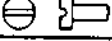
<u>Part No.</u>	<u>Description</u>
<b>ACCESSORIES</b>	
X-3534-138-0	Reel Ass'y, R-11B
1-534-049-51	Cord, connection; RK-74
3-141-188-00	Spacer, 10" reel
3-542-008-00	Cleaning Tip
3-542-101-00	Adaptor, reel
3-780-831-11	Manual, instruction

- Hardware Nomenclature -

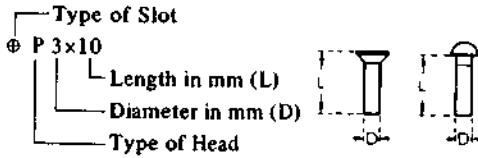
<p><b>P</b> - Pan Head Screw ..... </p> <p><b>PS</b> - Pan Head Screw with Spring Washer ..... </p> <p><b>K</b> - Flat Countersunk Head Screw ..... </p> <p><b>B</b> - Binding Head Screw ..... </p> <p><b>RK</b> - Oval Countersunk Head Screw ..... </p> <p><b>T</b> - Truss Head Screw ..... </p> <p><b>R</b> - Round Head Screw ..... </p> <p><b>F</b> - Flat Fillister Head Screw ..... </p>	<p><b>SC</b> - Set Screw ..... </p> <p><b>E</b> - Retaining Ring (E Washer) ..... </p> <p style="margin-left: 40px;"> <b>W</b> - Washer  <b>SW</b> - Spring Washer  <b>LW</b> - Lock Washer  <b>N</b> - Nut         </p> <p><b>- Example -</b></p> <p>  </p>
---	--

**Sony Corporation**

© 1975

- 60 -

Printed by: Schaltungsdienst Lange, Berlin (GERMANY)