

TC-730

E Model



STEREO TAPECORDER

SPECIFICATIONS

Power Requirements:	AC 100, 110, 120, 127, 220 or 240 V 50/60 Hz	Two AUX Inputs	Impedance : 100 k Ω Maximum sensitivity : -22 dB (62 mV)									
Power Consumption:	AC 120 W	REC/PB connector	Input impedance : 10 k Ω Input level : -33 dB (17.4 mV)									
Track System:	4-track 2-channel stereo and mono	Outputs:	Two LINE Outputs Load impedance : 100 k Ω Output level : 0 dB (0.775 V)									
Reel Size:	7" (18 cm) or smaller	HEADPHONE Output	Load impedance : 8 Ω Output level : -36 dB (12.3 mV) at LEVEL "1" -28 dB (30.8 mV) at LEVEL "2"									
Tape Speed:	7 1/2 ips (19 cm/s), 3 3/4 ips (9.5 cm/s), 1 7/8 ips (4.8 cm/s)	REC/PB connector	Output impedance : 10 k Ω Output level : 0 dB (0.775 V)									
Recording Time:	<table><thead><tr><th>Tape speed</th><th>4-track stereo</th><th>4-track mono</th></tr></thead><tbody><tr><td>7 1/2 ips (19 cm/s)</td><td>1.5 hrs</td><td>3 hrs</td></tr><tr><td>3 3/4 ips (9.5 cm/s)</td><td>3 hrs</td><td>6 hrs</td></tr></tbody></table>	Tape speed	4-track stereo	4-track mono	7 1/2 ips (19 cm/s)	1.5 hrs	3 hrs	3 3/4 ips (9.5 cm/s)	3 hrs	6 hrs	Two EXT SPKR	Load impedance : 8 Ω Output level : 17 dB (5.6 V)
Tape speed	4-track stereo	4-track mono										
7 1/2 ips (19 cm/s)	1.5 hrs	3 hrs										
3 3/4 ips (9.5 cm/s)	3 hrs	6 hrs										
Frequency Response:	(with SONY SLH tape) 20 ~ 30,000 Hz at 7 1/2 ips (19 cm/s) 20 ~ 20,000 Hz at 3 3/4 ips (9.5 cm/s) (with standard tape) 20 ~ 25,000 Hz at 7 1/2 ips (19 cm/s) 20 ~ 17,000 Hz at 3 3/4 ips (9.5 cm/s) 30 ~ 9,000 Hz at 1 7/8 ips (4.8 cm/s)	Maximum Power Output:	3.7 W x 2 with built-in speakers 15 W x 2 with external speakers									
Signal-to-Noise Ratio:	56 dB (with SLH tape) 53 dB (with standard tape)	Built-in Speaker:	4 x 6" (10 x 15 cm) x 2 impedance 32 Ω									
Flutter and Wow:	0.06 % at 7 1/2 ips (19 cm/s) 0.1 % at 3 3/4 ips (9.5 cm/s) 0.2 % at 1 7/8 ips (4.8 cm/s)	Semiconductors:	51 transistors, 25 diodes and 1 integrated circuit									
Harmonic Distortion:	1.2 %	Dimensions:	21 (W) x 19 5/8 (H) x 8 15/16" (D) (533 x 498 x 227 mm)									
Recording		Weight:	51 lb 13 oz (23.5 kg)									
Bias Frequency:	Approx. 160 kHz											
Inputs:	Two MIC Inputs Impedance : low impedance Maximum sensitivity : -72 dB (0.2 mV)											

SONY®

SERVICE MANUAL

TABLE OF CONTENTS

<u>Section</u>	<u>Title</u>	<u>Page</u>	<u>Section</u>	<u>Title</u>	<u>Page</u>
	Specifications	1	4. DIAGRAMS		
1. GENERAL DESCRIPTION		3	4-1. Schematic Diagram		39
1-1. Block Diagram		3	4-1-1. Audio Amp and Bias OSC Circuit		39
1-2. Major Parts Locations		4 ~ 5	4-1-2. System Control Circuit		41
1-3. Switch Location		6	4-2. Mounting Diagram		43
CIRCUIT DESCRIPTION			4-2-1. Record Amp Circuit Board		43
1. Record Amp Circuit		7	4-2-2. Record Equalizer Circuit Board		46
2. Muting Circuit		7	4-2-3. Playback Amp Circuit Board		48
3. System Control		8	4-2-4. Bias OSC Circuit Board		51
3-1. Brake Solenoid PM602		8	4-2-5. SOS/ECHO Circuit Board		54
3-2. Reel Motor Circuit		8	4-2-6. Speaker Selector Switch Circuit Board		55
3-3. Pinch Roller Solenoid PM601		8	4-2-7. Tone Control Circuit Board		56
3-4. Solenoid Operating Voltage		8	4-2-8. Power Amp Circuit Board		58
3-5. S612		8	4-2-9. Relay Circuit Board		60
4. Ac Servo Circuit		9	4-2-10. Power Supply Circuit Board		63
4-1. Principle		9	4-2-11. Servo Control Circuit Board		66
4-2. Servo Amplifier Operation		9	4-2-12. Reverse Switch Circuit Board		67
4-3. Motor Speed Deviation from Intended Value		10	4-3. Level Diagram		68
Sequence of Switch Operation		12	5. ELECTRICAL PARTS LIST		70
2. DISASSEMBLY			6. EXPLODED VIEWS		
2-1. Cabinet Removal		13	6-1. Cabinet - top view -		77
2-2. Head Deck Removal		14	6-2. Head Deck - top view -		79
2-3. Record Equalizer Circuit Board Removal		14	6-3. Amplifier Chassis Panel - top view -		81
2-4. Reverse Switch Circuit Board Removal		14	6-4. Amplifier Chassis - top view -		83
3. ADJUSTMENT PROCEDURES			6-5. Chassis - top view - (1)		85
3-1. Mechanical Adjustments		15	6-6. Chassis - top view - (2)		87
3-2. Electrical Adjustments		25	6-7. Chassis - top view - (3)		88
			6-8. Chassis - bottom view -		89
			6-9. Packing		90
			7. HARDWARE		91
			Hardware Nomenclature		91

When ordering replacement parts, you should use PART NUMBER listed on the Parts Lists or shown in the EXPLODED VIEW. The reference number should not be used for ordering purposes.

1-2. MAJOR PARTS LOCATIONS

Cabinet — Top View —

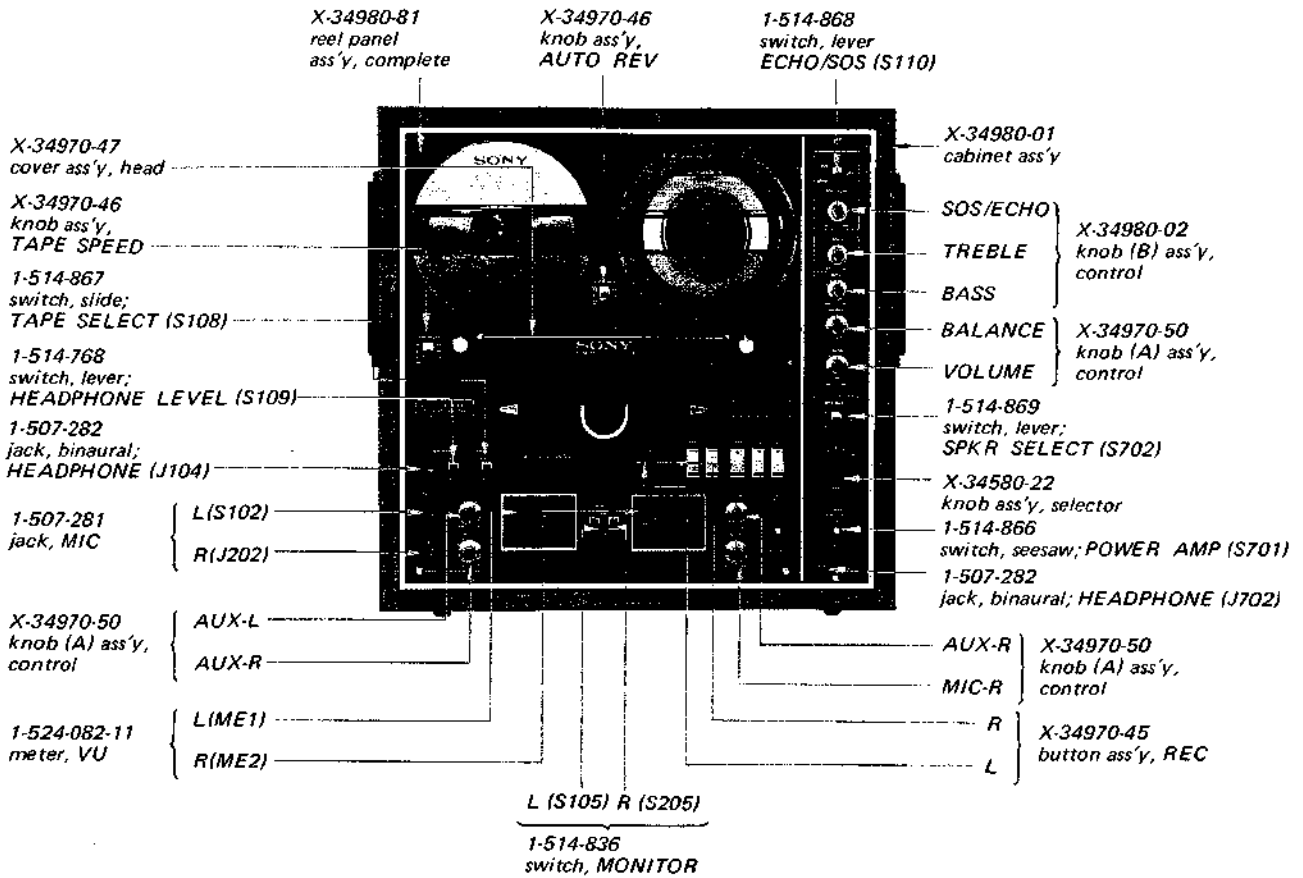

Cabinet — Side Views —

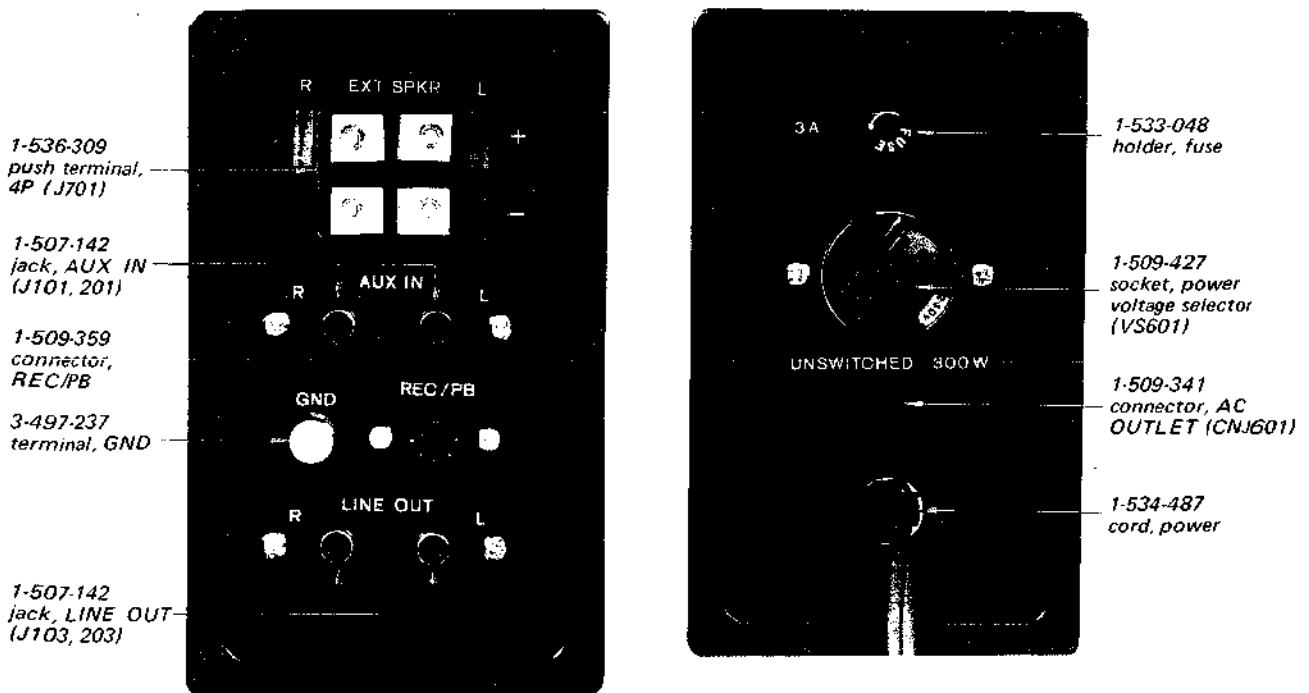

Chassis – Top View –

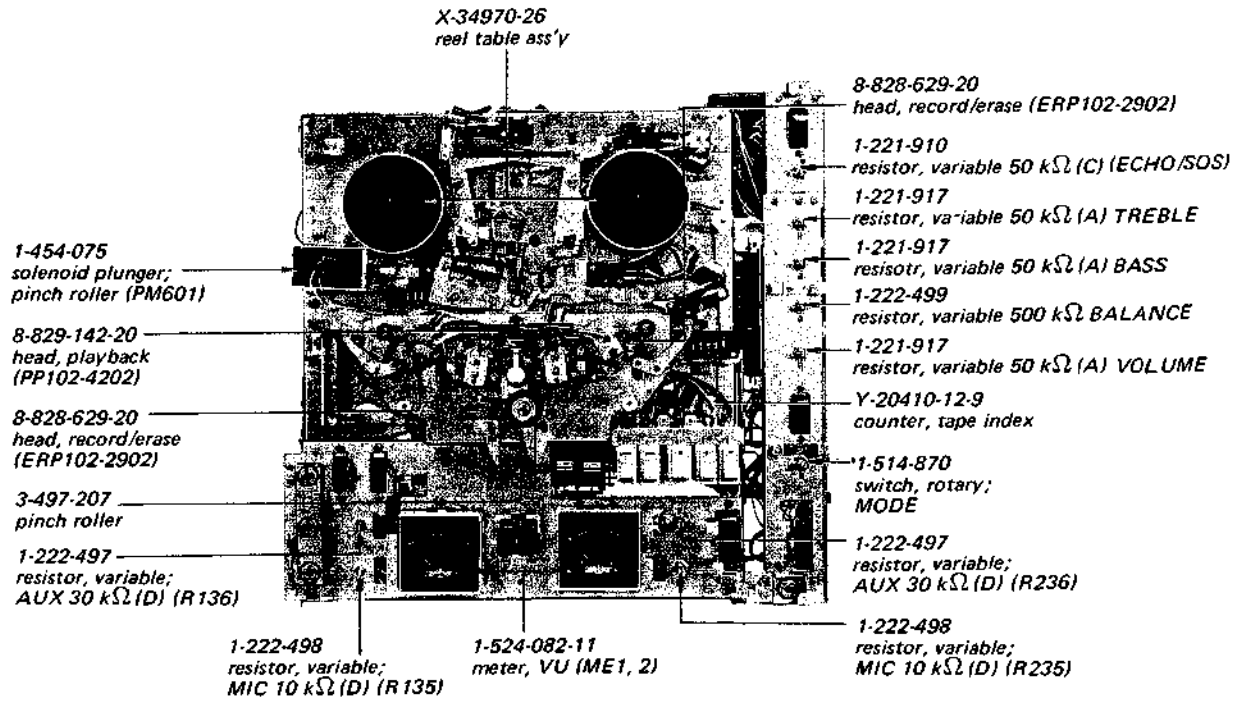

Chassis – Bottom View –

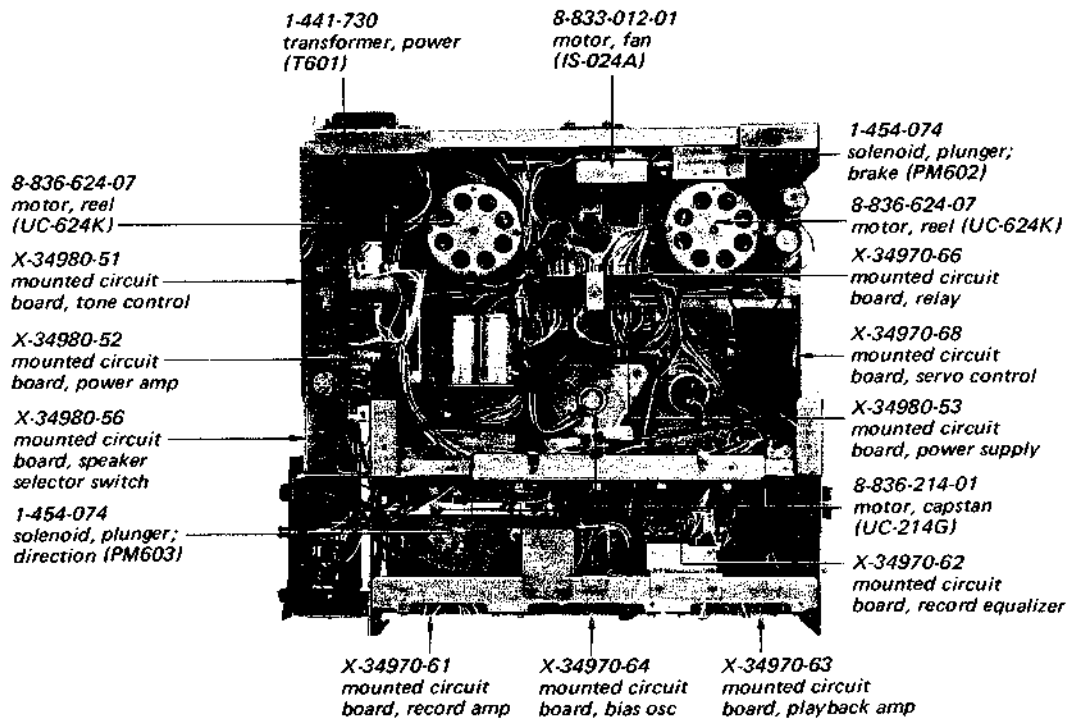

1-3. SWITCH LOCATION

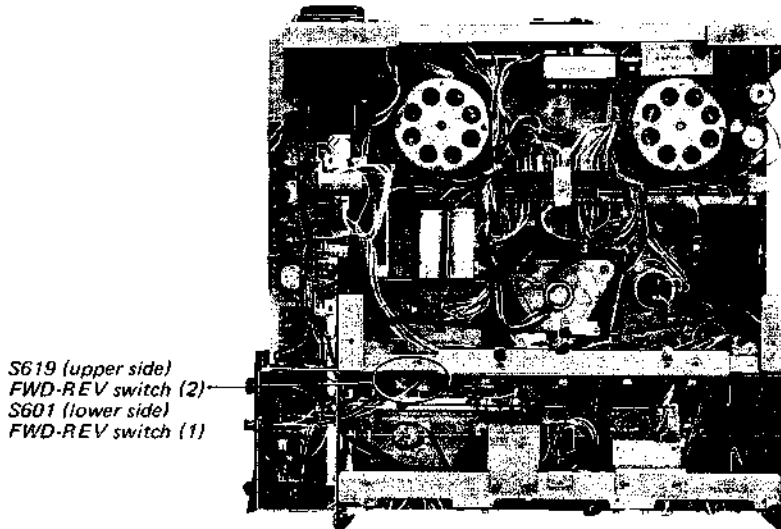
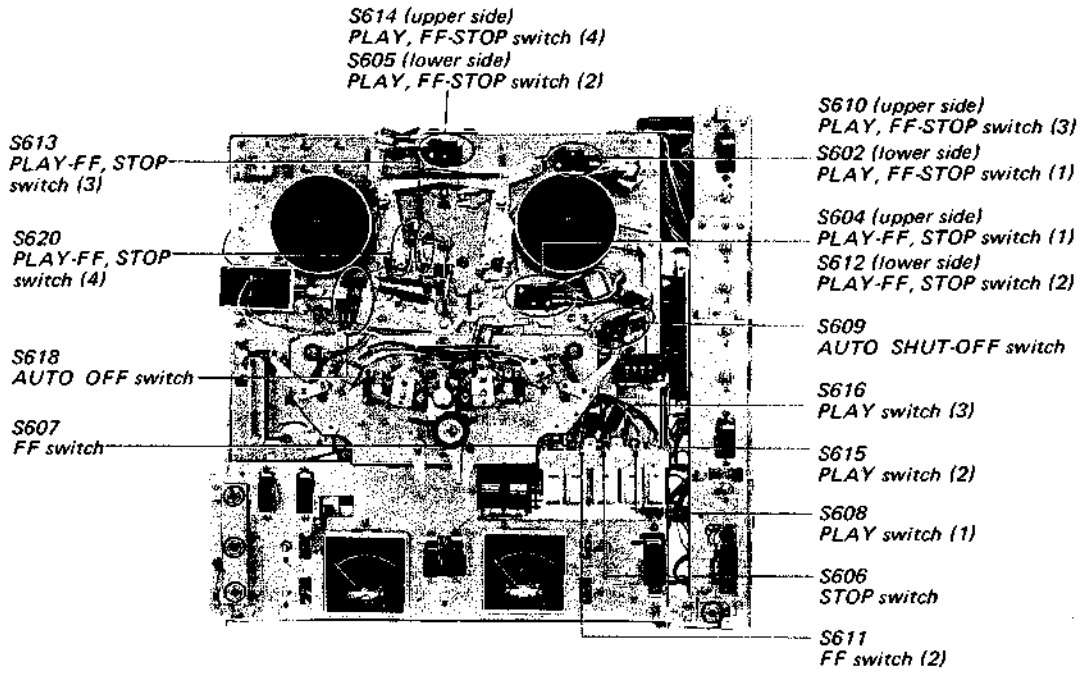

CIRCUIT DESCRIPTION

The following describes operation of main circuit:

1. RECORD AMP CIRCUIT

First stage of the record amplifier comprises NPN and PNP type transistors connected in parallel. This circuit improves linearity characteristics of record amplifier for MIC jack input signals. Approximately 50 dB linearity can be obtained. Therefore, can record signals with greater input level (approximately -10 dB, 0.25 V to MIC jack) with low distortion. Linearity for conventional circuit which has only one transistor is approximately 30 dB.

2. MUTING CIRCUIT

During direction change of tape transport (about three seconds), from the time when tape stops moving until tape motion reverses and recovers to normal tape speed, B+ voltage of bias oscillator is cut off in record mode and the muting circuits (Q306 and Q406) of playback amplifier are activated in playback mode.

When turning POWER switch ON, the multivibrator (Q504 and Q505) is kept stable as follows:

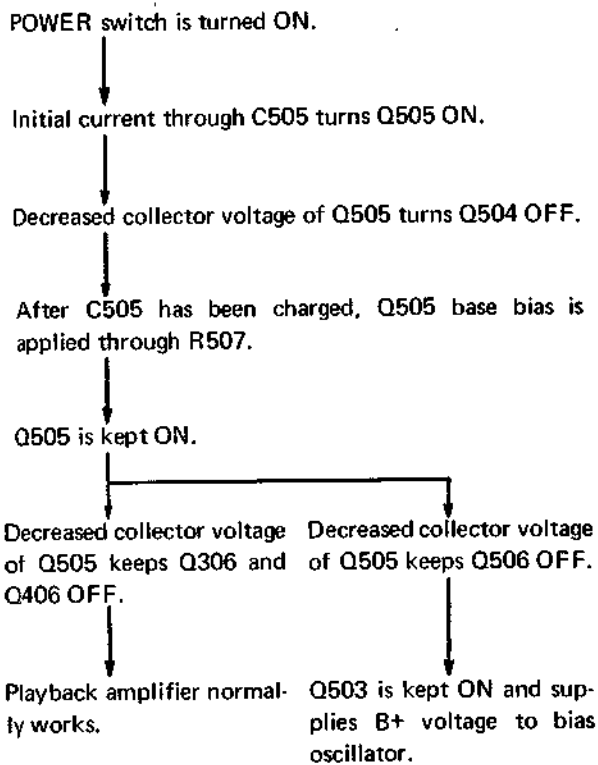

When changing the unit from FWD mode to REV mode or vice versa, this circuit acts as follows:

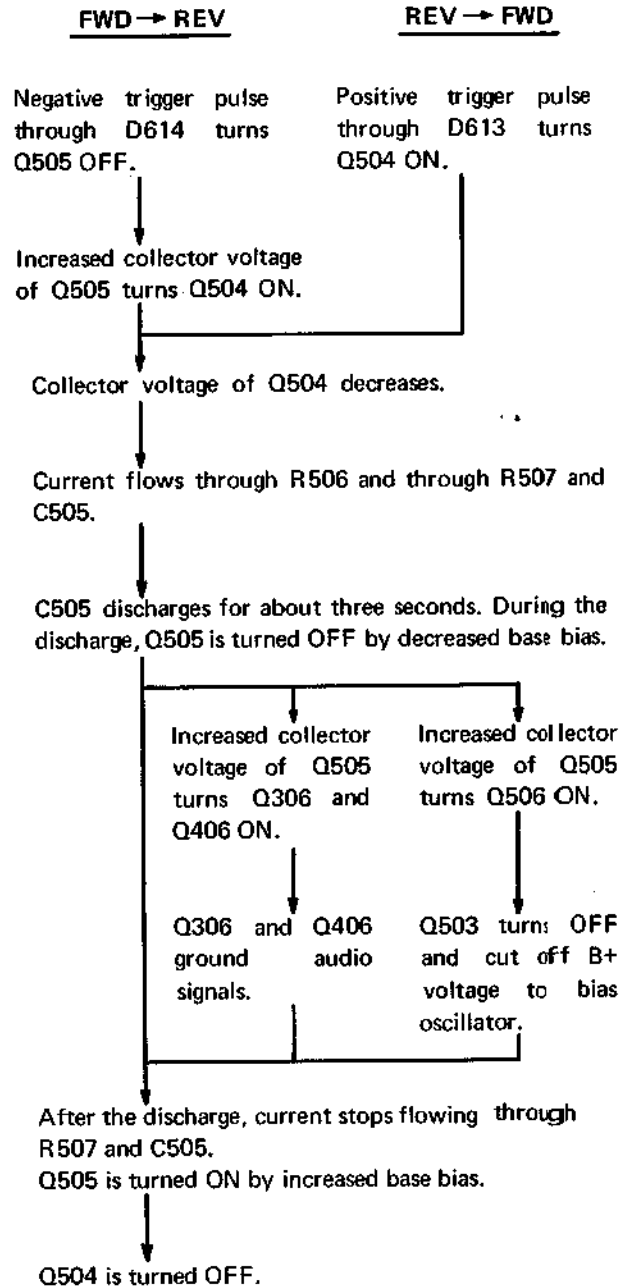

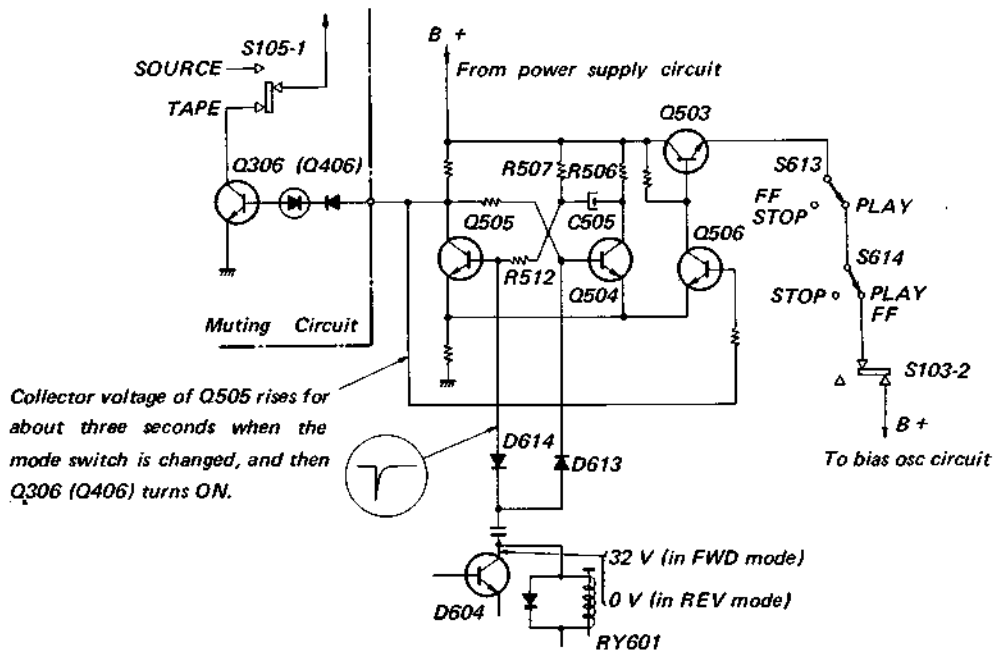

Fig. 1. Muting circuit

3. SYSTEM CONTROL

3-1. Brake solenoid PM602

When FWD button is pushed, S608 turns ON. Then high voltage (about 170 volts dc) rectified by D604 is applied to PM602 through S605. PM602 is energized.

3-2. Reel motor circuit

The motor current flows as follows:

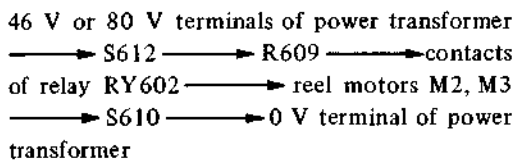

3-3. Pinch roller solenoid PM601

When S602 is turned ON by solenoid PM602, high voltage (about 170 volts dc) rectified by D604 is applied to PM601 through S604. PM601 is energized.

3-4. Solenoid operating voltage

Solenoids (for brake, pinch roller, and tape direction) are energized by high voltage (about 170 volts dc) and kept energized by low voltage (about 30 volts dc).

3-5. S612

This switch supplies a high reel-motor-driving voltage (80 volts ac) to make strong tape tension in a starting moment, because of tape slack elimination. When pressing FWD or REV button, S612 supplies 80 volts ac for about one second until pinch roller solenoid PM601 actuates S612. After solenoid PM601 has actuated S612, S613 supplies 46 volts ac for normal tape tension.

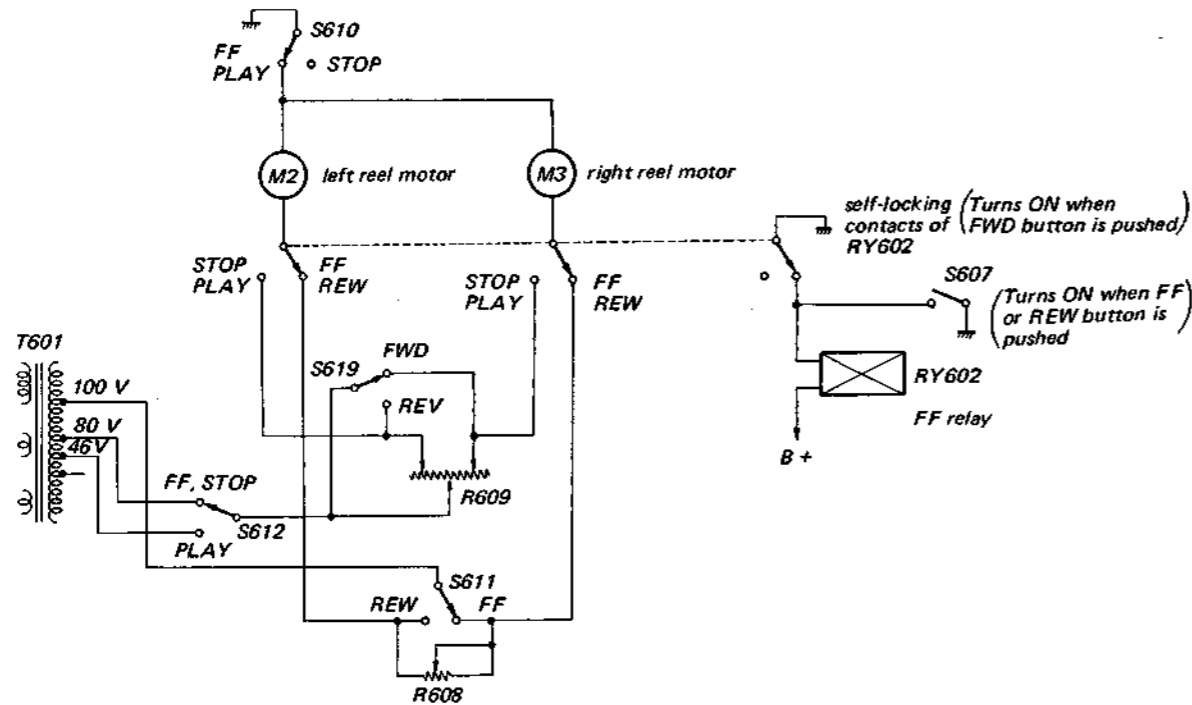

Fig. 2. Reel motor circuit

4. AC SERVO CIRCUIT

The Model TC-730 employs ac servo amplifier circuit and keeps tape speed constant.

4.1. Principle

See block diagram in Fig. 3. Motor speed determined by voltage E_m can be changed by voltage E_r .

$$E \text{ (fixed)} = E_m + E_r$$

When motor speed becomes faster or slower than intended speed according to external disturbances, the intended motor speed can be obtained again by changing voltage E_r , or by changing resistance R . The frequency generator FG in the motor detects motor speed deviation. Servo amplifier changes resistance R according to the deviation. TC-730 uses impedance R between collector and emitter of transistor $Q901$ instead of resistance R as shown in Fig. 4. Impedance R can be changed by the base voltage. The motor speed can be kept stable by controlling the base voltage for the motor speed deviation. The bridge type rectifier comprising four diodes makes current flow through transistor $Q901$ in the direction shown by the arrow in Fig. 4.

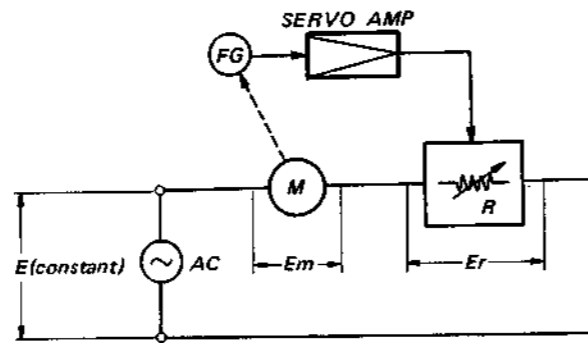

Fig. 3. Servo control system block diagram

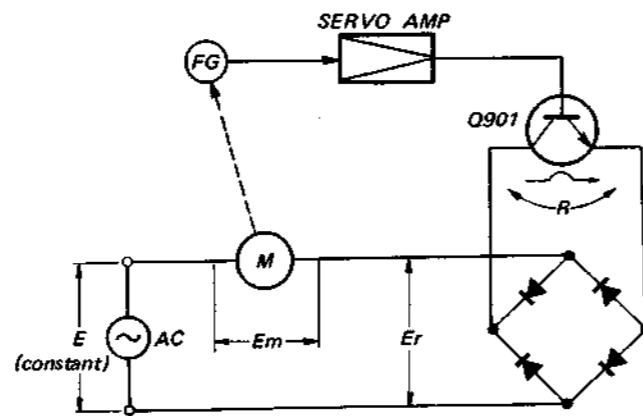

Fig. 4. Q901 instead of resistance R

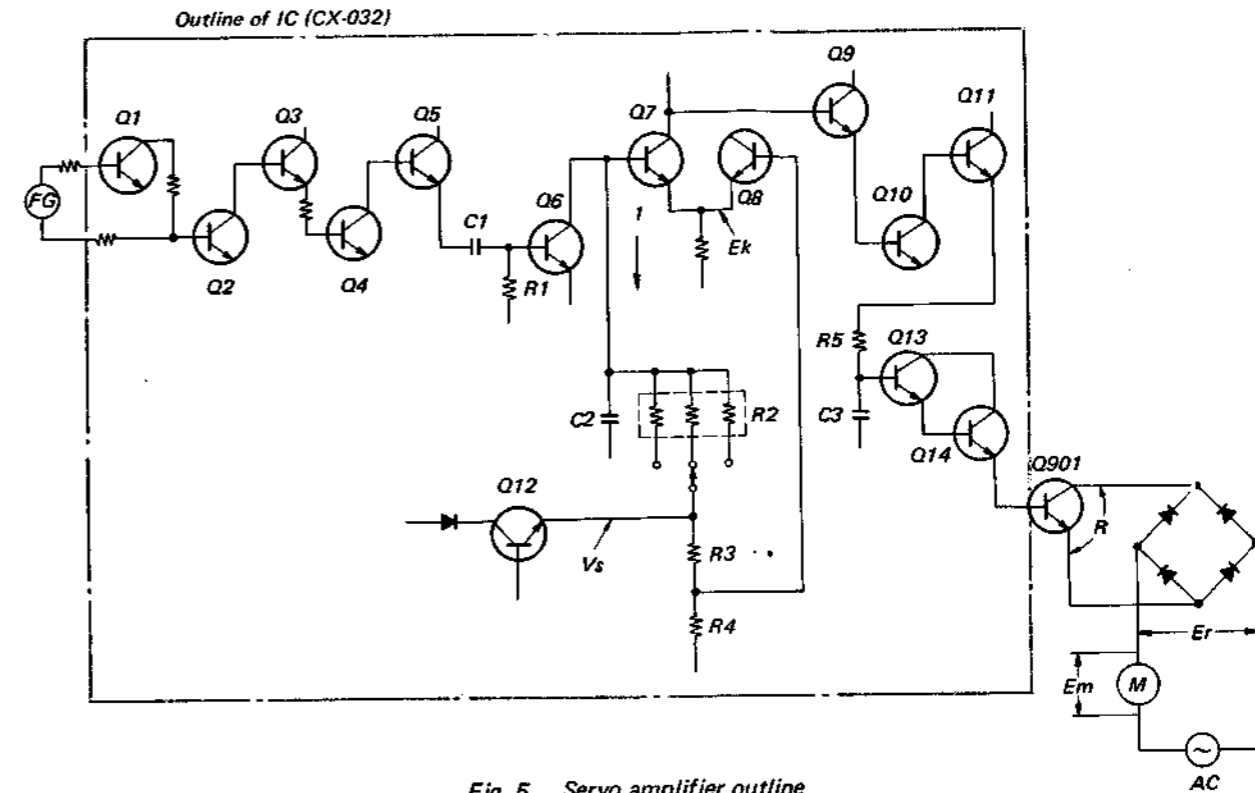

Fig. 5. Servo amplifier outline

4-2. Servo amplifier operation

Servo amplifier which changes impedance R operates as follows: See Fig. 5 and Fig. 6.

- 1) Sine wave signal generated by frequency generator FG is transferred to bases of $Q1$ and $Q2$. Since base bias voltages of $Q1$ and $Q2$ are set to saturation region, sine wave signal is waveshaped to square wave signal shown by (A) in Fig. 6.
- 2) Square wave signal from $Q2$ is amplified by $Q3$, $Q4$ and $Q5$. It is transferred to differentiating circuit comprising $C1$ and $R1$ and is waveshaped to pulse shown by (B) in Fig. 6. Then it is transferred to base of $Q6$.
- 3) Dc voltage V_s stabilized by $Q12$ is divided by $R3$ and $R4$. Then it is transferred to base of $Q8$ and keeps the emitter voltage E_k of $Q8$ (also that of $Q7$) constant.
- 4) V_s also charges $C2$ according to the time constant decided by $C2$ and $R2$. The charged voltage is applied to collector of $Q6$. When pulse shown by (B) in Fig. 6 is transferred to base of $Q6$, $Q6$ repeats ON and OFF states. $C2$ discharges while $Q6$ makes current flow as shown by the arrow (1) in Fig. 5. Thus sawtooth wave signal shown by (C) in Fig. 6 is obtained at collector of $Q6$.

- 5) The sawtooth wave signal is supplied to base of $Q7$. Since the emitter voltage E_k is kept constant, $Q7$ turns ON only when the peak value of sawtooth wave signal is greater than E_k . When $Q7$ turns ON, the negative pulse shown by (D) in Fig. 6, appears at collector of $Q7$.
- 6) This pulse is amplified by $Q9$, $Q10$ and $Q11$, and its polarity is inverted. The positive pulse is transferred to the integrator comprising $R5$ and $C3$, and is waveshaped as shown by (E) in Fig. 6. After being amplified by $Q13$ and $Q14$, it is transferred to base of $Q901$. And this base voltage changes impedance between collector and emitter of $Q901$ and controls motor speed.

4-3. Motor speed deviation from intended value

- 1) When motor speed becomes faster (Fig. 7);
Switching speed of $Q6$ becomes faster since frequency of frequency generator FG increases. Collector voltage of $Q6$ is grounded before it becomes greater than emitter voltage E_k (constant) because of short charging time for $C2$. The peak value of the sawtooth wave signal at base of $Q7$ is less than E_k . Thus $Q7$ turns OFF, and base voltage of $Q901$ decreases since the pulse is not supplied to base of $Q9$. When

impedance R becomes greater, motor voltage E_m decreases and motor speed decreases to the intended.

2) When motor speed becomes slower (Fig. 8);

Switching speed of Q6 becomes slower since frequency of frequency generator FG decreases. Collector voltage of Q6 is grounded after it becomes greater than emitter voltage of Q7 because of sufficient charging time for C2. The peak value of the sawtooth wave signal at base of Q7 is higher than E_k . Thus Q7 turns ON for T seconds, and base voltage of Q901 increases since the pulse is supplied to base of Q9, when impedance R becomes less, motor voltage E_m increases, and motor speed increases to the intended speed. Thus by changing the time T motor speed is controlled.

Time T is determined by charging-time of C2 (the inclination of the sawtooth wave). In this ac servo circuit, the time constant ($C2 \times R2$) for charging time is determined by R2 for the specified tape speed.

3) Circuit operation when motor starts running;

Just after the power switch is turned ON, Q6 is still turned OFF since signal is not supplied from the frequency generator (motor is not running). C2 is charged rapidly, and greater voltage than E_k is applied to base of Q7. When base voltage of Q901 increases, ac voltage is

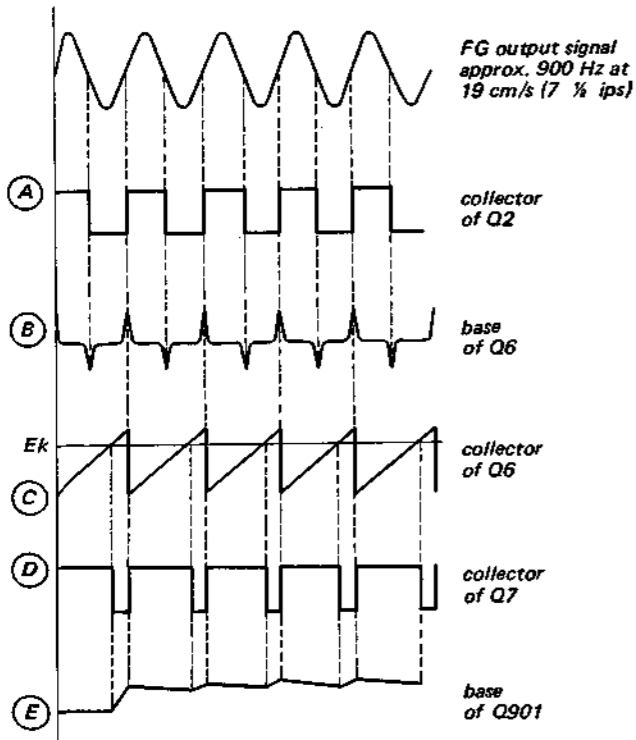

Fig. 6. Waveform at each point

applied to the motor and the motor starts running rapidly. In the FF mode, the servo circuit does not work and ac voltage is applied to the motor directly. Then motor rotates at full speed.

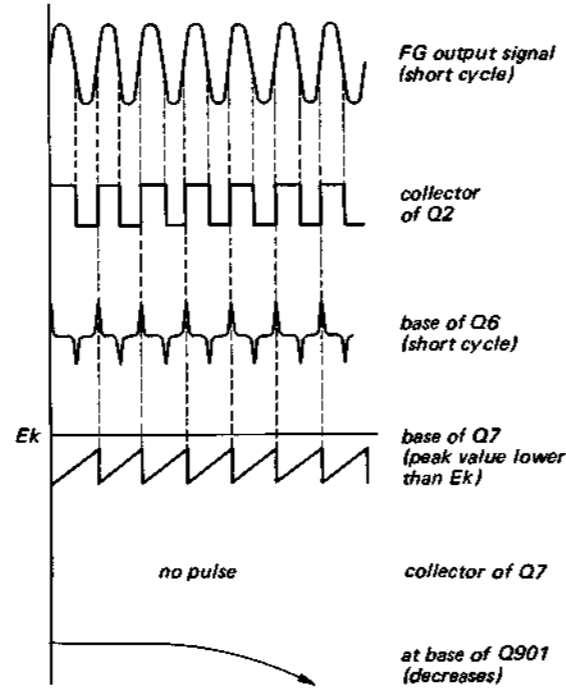

Fig. 7. When motor speed becomes faster

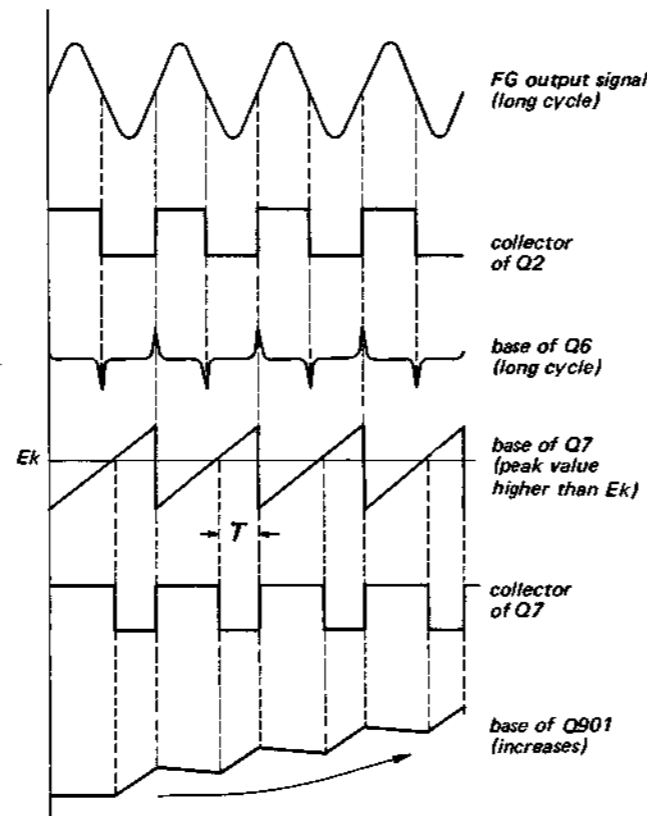
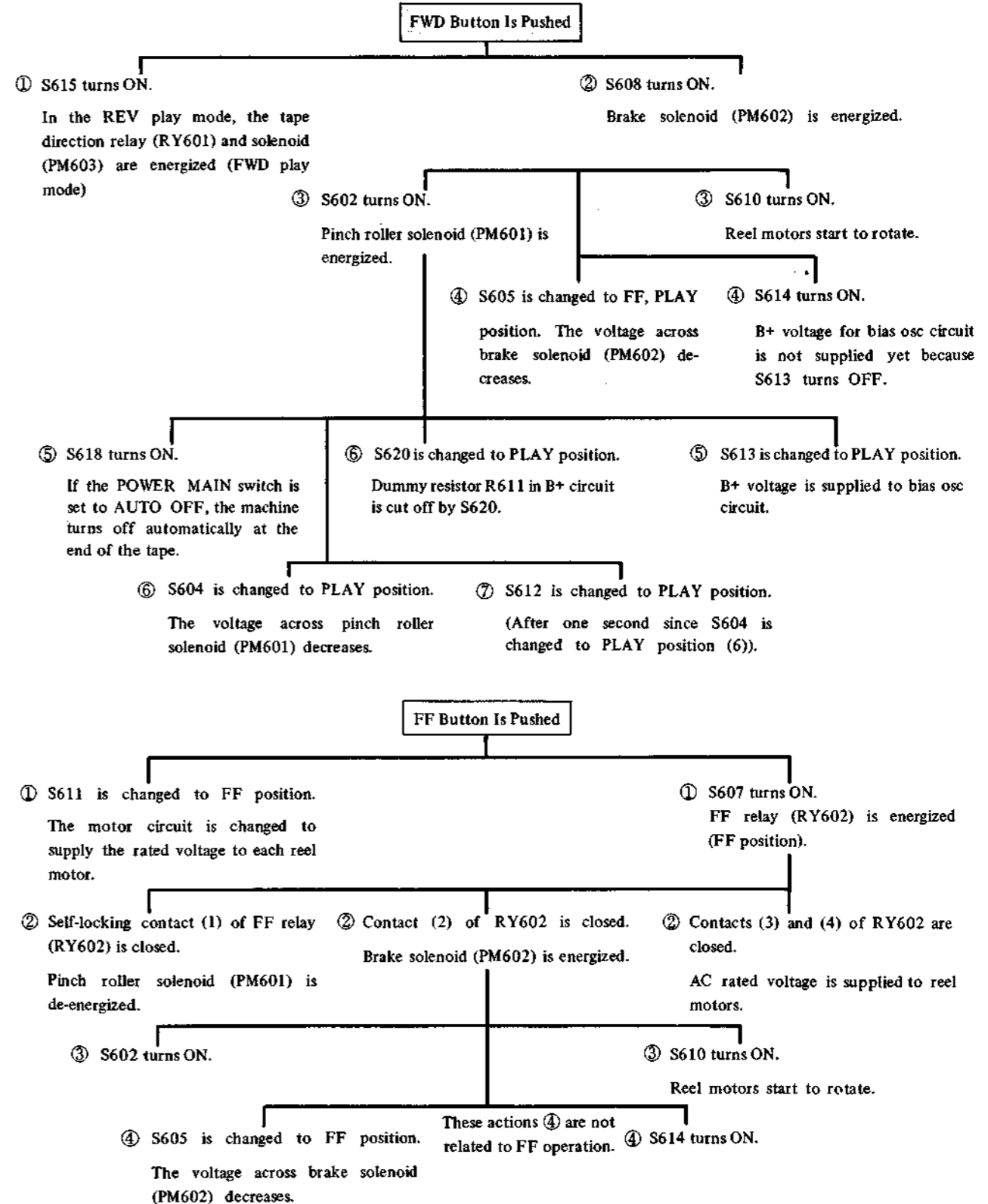

Fig. 8. When motor speed becomes slower

SEQUENCE OF SWITCH OPERATION

Note: The number in circle shows the sequence of switch operation when the mode is changed.



SECTION 2 DISASSEMBLY

2-1. CABINET REMOVAL

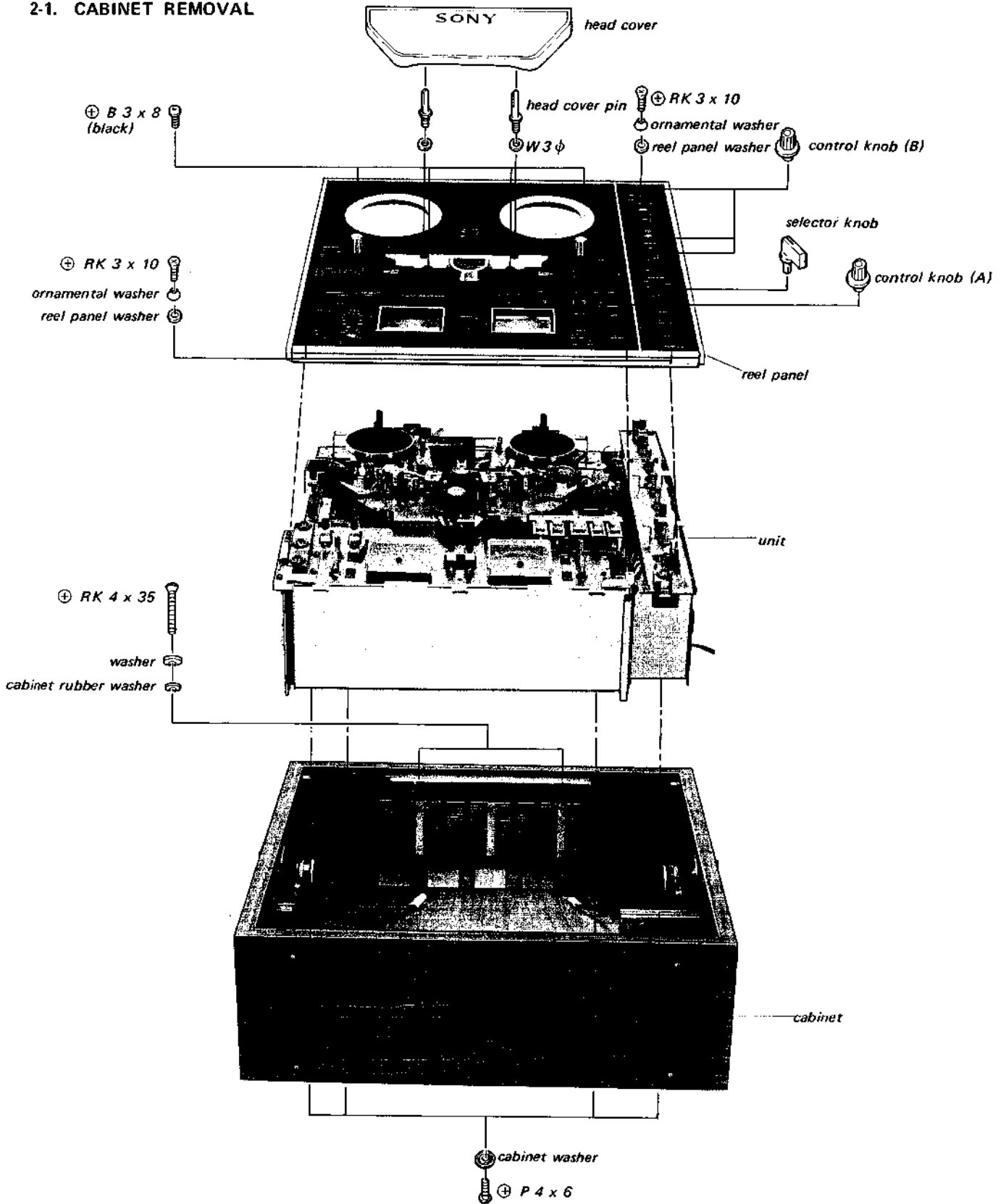

2-2. HEAD DECK REMOVAL

1. Remove the FWD and REV lamps.
2. Remove the five screws shown in Fig. 2-2. Lift off the head deck.

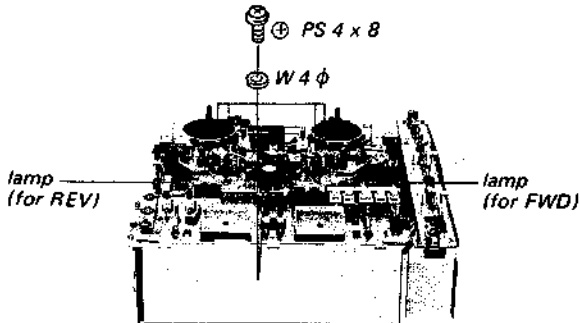

Fig. 2-2. Head deck removal

2-3. RECORD EQUALIZER CIRCUIT BOARD REMOVAL

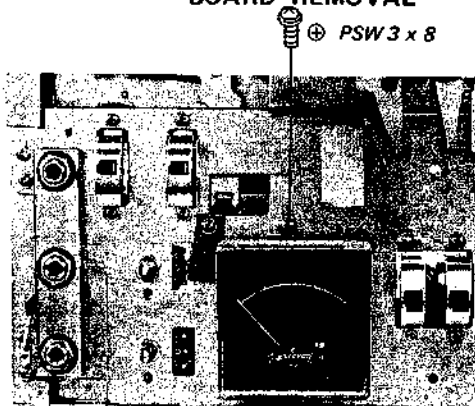

Fig. 2-3. Record equalizer circuit board removal

Note: After reattaching, make the equalizer switch (S107) position adjustment (See page 15).

2-4. REVERSE SWITCH CIRCUIT BOARD REMOVAL

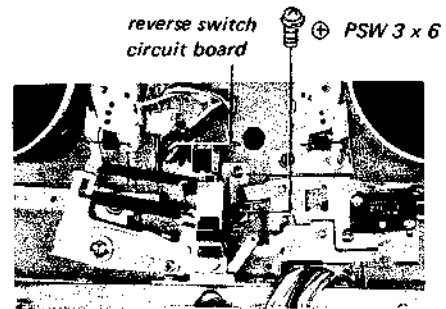

Fig. 2-4. Reverse switch circuit board removal

Note: Pay attention not to cut the head lead wires.

CAUTION:

- 1) Install the playback and bias osc. circuit boards, after the levers are perfectly hooked to the holes of the slider of the slide switches.
- 2) The lead wire of microswitch has a connector, which is connected to the other lead wire with a special jig.
If the lead wire is cut or the connector is damaged, solder the lead directly to the microswitch terminal with an insulating tape wound around the terminal.
- 3) Never put the unit upside down on the hard plate with the head cover removed. The pin of the tape shifter, the shut-off arm pin, the tension arm and others will be bent because of the weight of the unit. If it is necessary to put the unit upside down, put it on a soft cloth with the head cover attached.

SECTION 3 ADJUSTMENT PROCEDURES

3-1. MECHANICAL ADJUSTMENTS

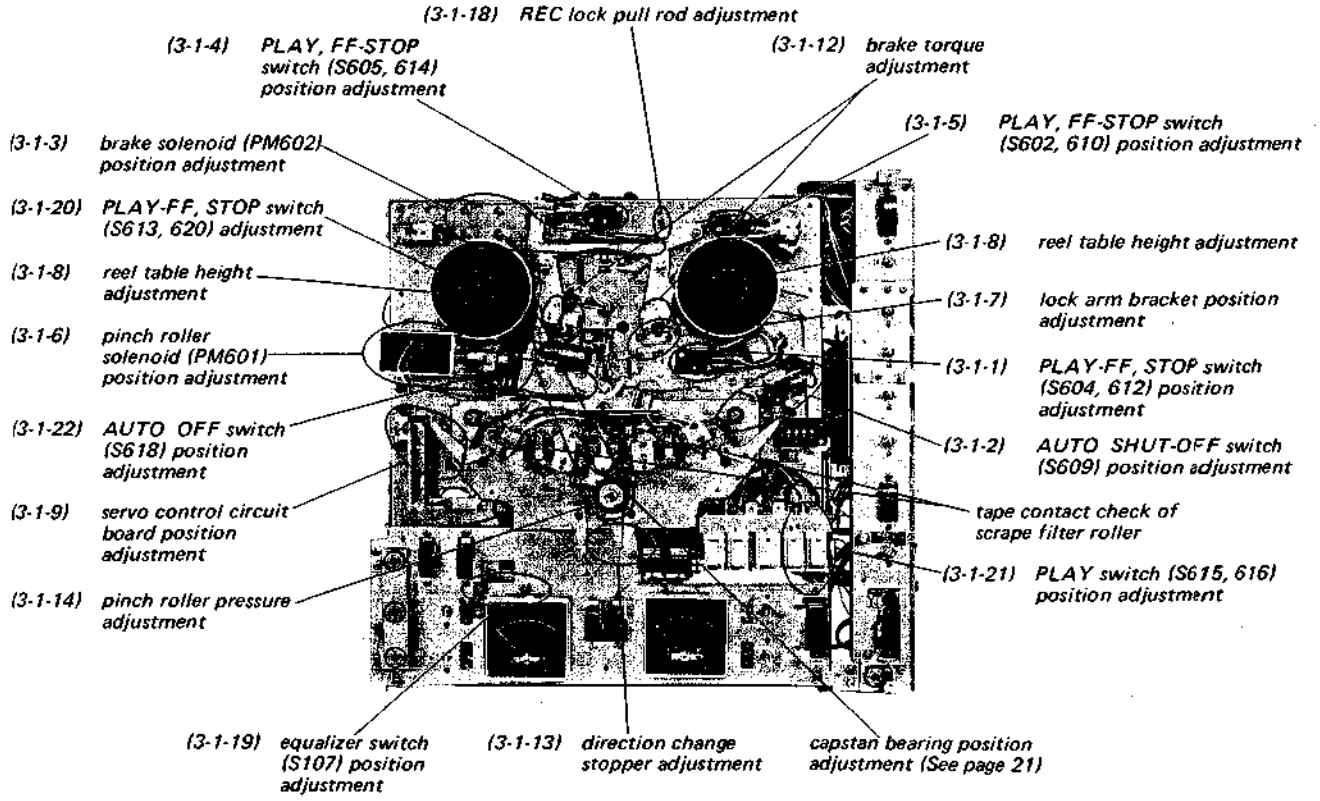

Fig. 3-1. Adjusting parts locations (1)

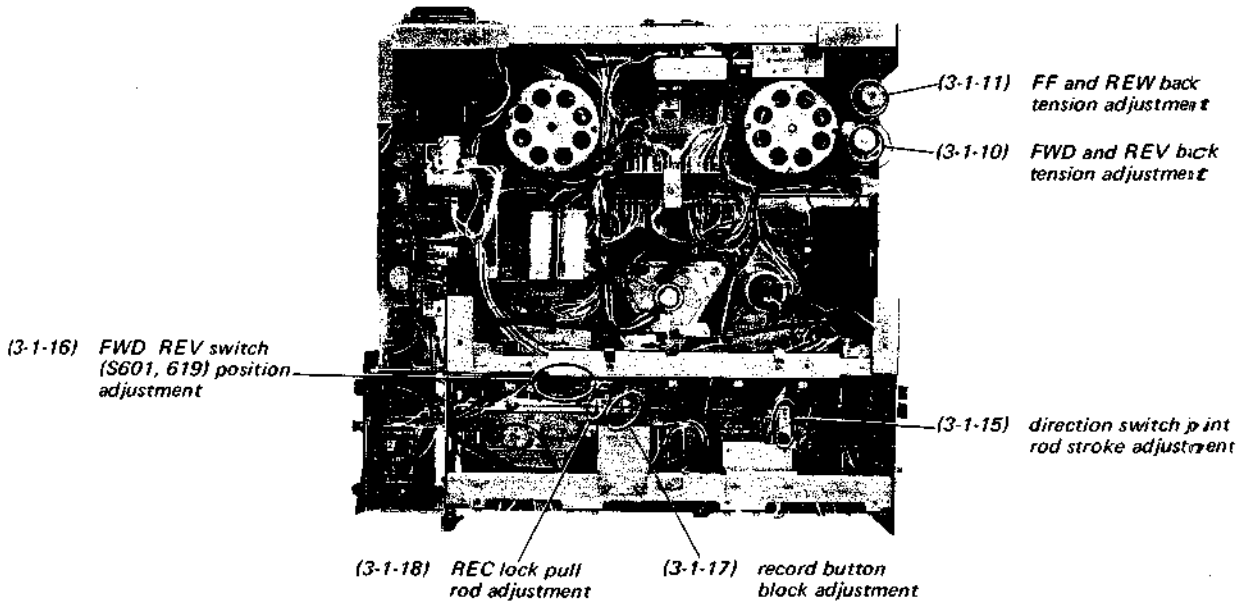

Fig. 3-2. Adjusting parts locations (2)

Note:

When the unit is set to FWD, REV, FF, REW, or REC mode with the no tape threaded, hold the both actuator pins so that the AUTO SHUT-OFF switch is activated (a rubber band or a piece of masking tape will hold the actuator as though tape were threaded on the unit).

3-1-1. PLAY-FF, STOP Switch (S604, 612) Position Adjustment

Make the following adjustments by loosening the two microswitch holding screws. See Fig. 3-3. After that, apply lock paint to them.

1. STOP mode (Lock arm B is locked)
Make sure that the actuator of microswitch is perfectly pushed with the plate spring as shown in Fig. 3-3.
2. FWD or REV mode (Lock arm B is released.)
The actuator of microswitch should not be pushed by the plate spring at all.
3. STOP to FWD (or REV) mode
S604 should be released approximately one second after S612 is released.

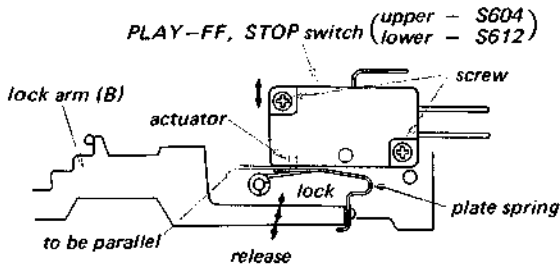

Fig. 3-3. PLAY-FF, STOP switch (S604, 612) position adjustment

3-1-2. AUTO SHUT-OFF Switch (S609, 618) Position Adjustment

1. Make sure that the bent portion of the actuator pin is positioned vertically against the chassis. If necessary, adjust by bending the base of the pin.
2. Loosen the two microswitch holding screws. Adjust the position of the microswitch so that the switch is turned ON by the actuator pin at the position shown in Fig. 3-4.
3. Apply lock paint to the screws.

Note:

Adjust for both AUTO SHUT-OFF switch in the same way.

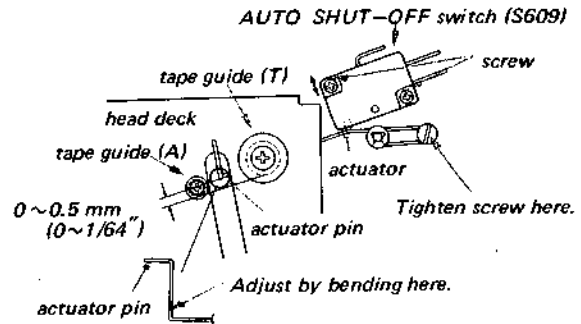

Fig. 3-4. AUTO SHUT-OFF switch (S609) position adjustment

3-1-3. Brake Solenoid (PM602) Position Adjustment

1. Turn OFF the power. Unhook either end of the spring and loosen the four solenoid holding screws. See Fig. 3-5.
2. Push the solenoid shaft to the full with a hand in the direction shown by the arrow. Adjust the position of the solenoid so that the clearance between the timing lever and the lock lever is 0 to 0.5 mm (1/64"). Make this adjustment perfectly otherwise an unusual noise is produced because of the vibration of the brake lever.
3. Hook the spring again and turn ON the power. Change the mode from FWD (REV) to STOP and vice versa several times. Make sure that the unusual noise is not produced. Adjust the position of the solenoid, if necessary.
4. Apply lock paint to the screws.

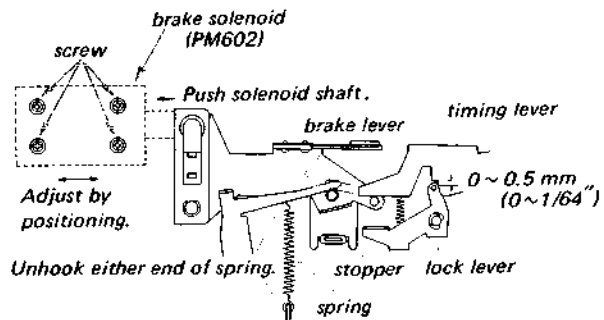

Fig. 3-5. Brake solenoid (PM602) position adjustment

3-1-4. PLAY,FF-STOP Switch (S605, 614) Position Adjustment

1. Place the unit in the FF or REW mode, to energize the brake solenoid. Check to see that the actuator of microswitch is perfectly pushed with the plate spring and also that the no clearance between the microswitch and the plate spring is obtained as shown in Fig. 3-6. If necessary, adjust the position of the microswitch by loosening the two switch holding screws.
2. Apply lock paint to the screws.

Note:

Be careful not to turn OFF the microswitch with the solenoid energized, as the thermistor (Pth601) on the relay circuit board will be damaged because of an unusual current.

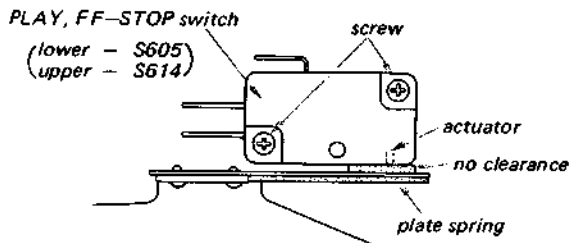

Fig. 3-6. PLAY, FF-STOP switch (S605, 614) position adjustment

3-1-5. PLAY,FF-STOP Switch (S602, 610) Position Adjustment

1. Place the unit in the FF or REW mode, to energize the brake solenoid. Check to see that the actuator of microswitch is perfectly pushed with the timing lever as shown in Fig. 3-7. If necessary, adjust the position of the microswitch by loosening the two switch holding screws.
2. Apply lock paint to the screws.

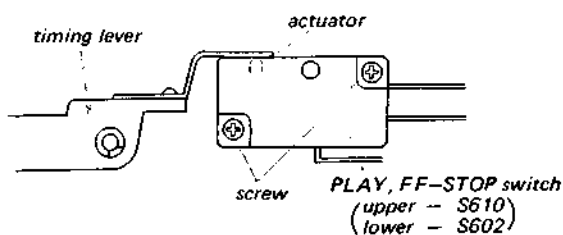

Fig. 3-7. PLAY, FF-STOP switch (S602, 610) position adjustment

3-1-6. Pinch Roller Solenoid (PM601) Position Adjustment

1. Loosen the three solenoid holding screws shown in Fig. 3-8.
2. Place the unit in the FWD or REV mode to energize the solenoid. Adjust the position of the solenoid so that the clearance between the pinch roller pressure adjusting plate and the plunger solenoid drive arm is 0.5 mm (1/64") to 1 mm (3/64"). Tighten the screws. The solenoid shaft should be attracted straight on the line and in parallel with the solenoid.
3. Apply lock paint to the screws.

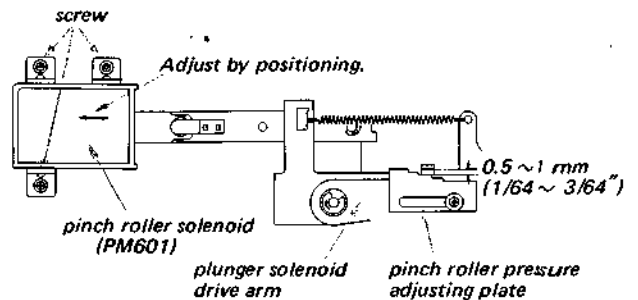

Fig. 3-8. Pinch roller solenoid (PM601) position adjustment

3-1-7. Lock Arm Bracket Position Adjustment

1. Make sure that the clearance between the lock arm (A) and the lock arm (B) is 0.5 ~ 1 mm (1/64 ~ 3/64") in the FWD (or REV) mode. In the STOP mode the clearance between the lock arm (A) and the lock arm (B) should be approximately 1 mm (3/64"). See Fig. 3-9.
2. Loosen the two lock arm bracket holding screws, if necessary. See Fig. 3-9.
3. Adjust the position of the lock arm bracket. Tighten the screws.
4. Apply lock paint to the screws.

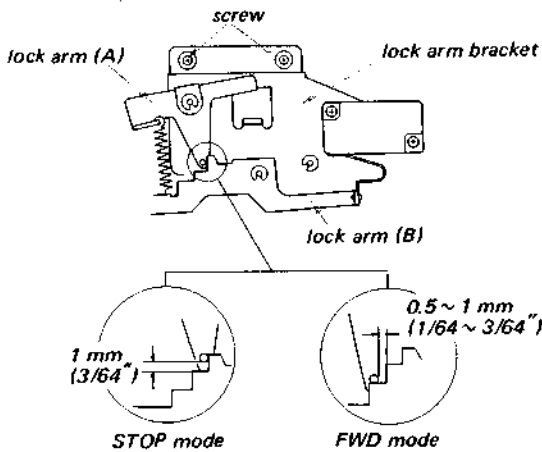

Fig. 3-9. Lock arm bracket position adjustment

3-1-8. Reel Table Height Adjustment

1. Use a 7 inch reel.
2. Thread the tape along the tape path. Place the unit in the FWD mode. If the tape touches either flange of the reel, adjust the reel table height by loosening the two set screws with an allen wrench. Here the both upper and lower clearances between the tape and the reel flange should be the same.
3. Tighten the set screws.

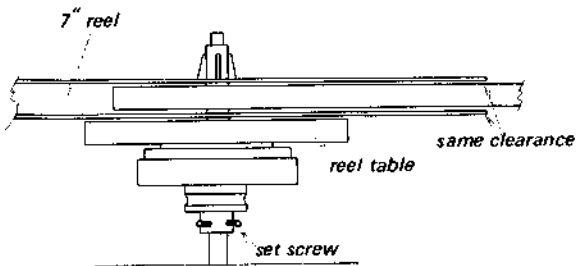

Fig. 3-10. Reel table height adjustment

3-1-9. Servo Control Circuit Board Position Adjustment

1. Loosen the two servo control circuit board holding screws shown in Fig. 3-11. Set the tape speed switch to the 9.5 cm/s (3-3/4 ips) position (center).
2. Thread the tape along the tape path. Place the unit in the FWD mode. Adjust the position of the servo control circuit board together with the heat sink so that the TAPE SPEED is 9.5 cm/s. Tighten the screws.

3. Make sure that the tape speed changes definitely, when the TAPE SPEED switch is slowly changed to the 4.8 cm/s, 9.5 cm/s and 19 cm/s positions. Readjust the position of the servo control circuit board, if necessary.
4. Apply lock paint to the screws.

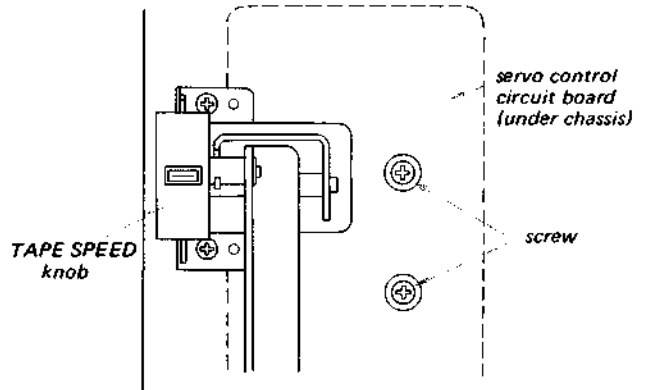

Fig. 3-11. Servo control circuit board position adjustment

3-1-10. FWD and REV Back Tension Adjustment

Note:

Instructions in [] are applied to the REV back tension torque adjustment.

1. Place a 7" reel with string wound several turns counterclockwise [clockwise] onto the FWD [REV] supply reel table. Tie the string to the spring scale.
2. Measure the back tensions by pulling the 0 to 400 g (14 oz) spring scale at approximately 9.5 cm/s (3-3/4 ips) speed in FWD [REV] mode. See Fig. 3-12. It should be 200 to 240 g.cm (2.78 to 3.32 oz. inch).
3. Adjust the slider of R609 by loosening the screws, if necessary.

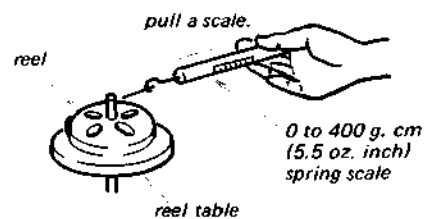

Fig. 3-12. FWD and REV back tension torque adjustment

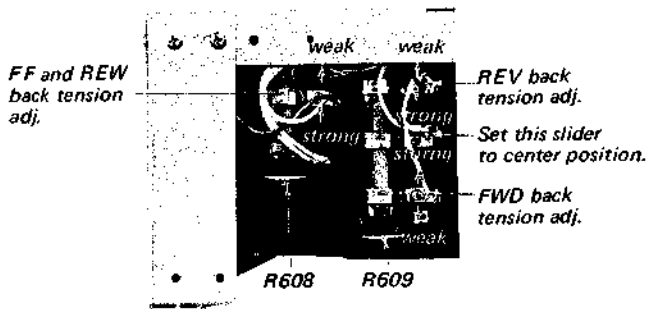

Fig. 3-13. Back tension torque adjusting parts location

3-1-11. FF and Rewind Back Tension Adjustment

Note:

Instructions in [] are applied to the REW back tension adjustment.

1. Place a 7" reel with string wound several turns counterclockwise [clockwise] on the hub onto the FF [REW] supply reel table. Tie the string to the spring scale.
2. Measure the back tension by pulling the 0 to 400 g (14 oz) spring scale at approximately 9.5 cm/s (3-3/4 ips) speed in FF [REW] mode. See Fig. 3-12. It should be 60 to 80 g·cm (0.83 to 1.1 oz·inch).
3. Adjust the slider of R608 by loosening the screw, if necessary.

3-1-12. Brake Torque Adjustment

This adjustment should be performed for both supply and take-up sides.

Note:

Instructions in [] are applied to the take-up brake torque adjustment.

1. Place the unit in the STOP mode.
2. Place a 7" reel with string wound several turns counterclockwise [clockwise] on the hub onto

the reel table. Tie the string to a spring scale.

3. Pull the scale in the direction shown by the red arrow, making sure that the string does not touch either flange of the reel. The reel table will rotate counterclockwise [clockwise]. Take a reading only when the reel table is in steady motion.
4. The scale reading should be 900 g·cm (12.5 oz·inch) to 1,200 g·cm (16.7 oz·inch).
5. Rewind the string by turning the reel clockwise [counterclockwise].
6. Turn string several times clockwise [counterclockwise] on the hub onto the reel table.
7. Pull the scale in the direction shown by the black arrow, making sure that the string does not touch either flange of the reel. The reel table will rotate clockwise [counterclockwise]. Take a reading only when the reel table is in steady motion.
8. The scale reading should be 300 g·cm (4.17 oz·inch) to 400 g·cm (5.55 oz·inch)
9. If the satisfied results are not obtained, adjust by changing the hooking position of spring.

Specification:

Brake Torque of Supply Reel

in clockwise turning 300-400 g·cm
(4.17-5.55 oz·inch)

in counterclockwise turning
900-1200 g·cm
(12.5-16.7 oz·inch)

Brake Torque of Take-up Reel

in clockwise turning 900-1200 g·cm
(12.5-16.7 oz·inch)

in counterclockwise turning
300-400 g·cm
(4.17-5.55 oz·inch)

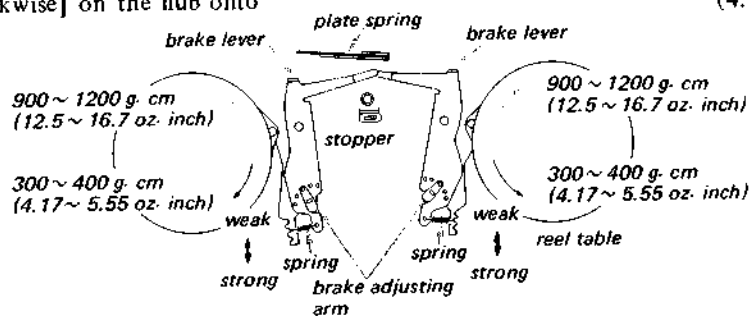

Fig. 3-14. Brake torque adjustment

3-1-13. Direction Change Stopper Position Adjustment

1. Loosen the stopper holding screw.
2. Place the unit in the FWD (or REV) mode. Adjust the position of the direction change stopper so that the clearance between the stopper and the tape direction change lever is 4 mm (5/32").
3. Change the mode from FWD to REV and vice versa several times. Make sure that the position of the pinch roller changes when the mode is changed.
4. Apply lock paint to the screws.

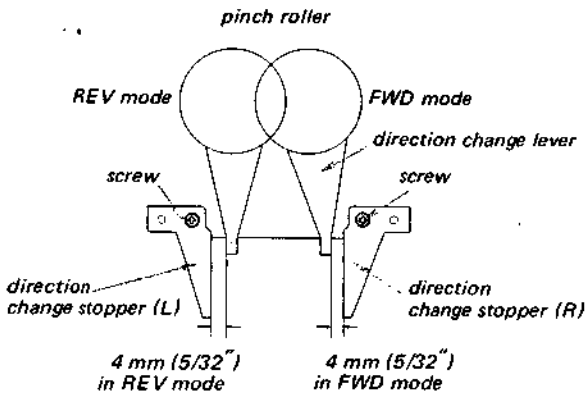

Fig. 3-15. Direction change stopper position adjustment

3-1-14. Pinch Roller Pressure Adjustment

1. Make a loop in a piece of string and attach the 0 to 1,600 g (3 lb 8 oz) spring scale around the base of the pinch roller shaft. See Fig. 3-16. Pull the scale. The pulling direction should be aligned with the pinch roller shaft and the capstan. Check the reading when the pinch roller just stops rotating. It should be 1,200 to 1,400 g (42 to 49 oz). If necessary, change the hooking position of the spring.

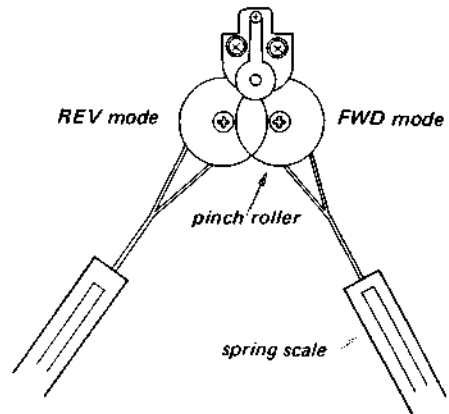
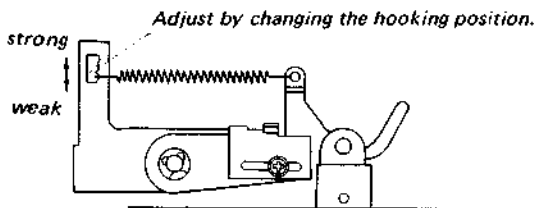

Fig. 3-16. Pinch roller pressure adjustment

3-1-15. Direction Switch Joint Rod Stroke Adjustment

1. Place the unit in the STOP mode. Push the tip of the direction switch lever slowly in the direction shown by the arrow in Fig. 3-17 as far as the slide switches on the playback and the bias osc. circuit boards are changed. (Do not move the position of switch).
2. Push the REV button. Make sure that the tip of the lever is pushed moreover by 0.5~1 mm (1/64 ~ 3/64") in the direction shown by the arrow by the solenoid.
3. Change the mode from the FWD to REV and vice versa several times and make sure that the slide switches are changed perfectly.
4. Change the position of direction switch joint rod to the direction change lever if necessary.

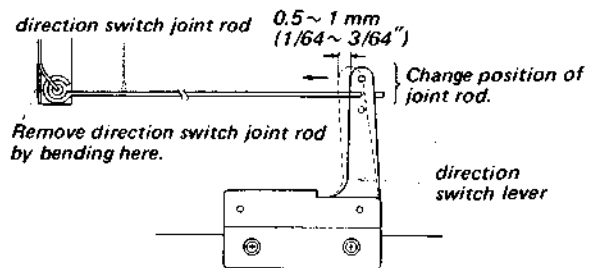

Fig. 3-17. Direction switch joint rod stroke adjustment

3-1-16. FWD-REV Switch (S601, 619) Position Adjustment

1. Loosen the two screws.
2. Place the unit in the REV mode to energize the direction change solenoid.
3. Adjust the position of the microswitch so that the actuator is perfectly pushed with the joint plate. Tighten the screws.
4. Apply lock paint to the screws.

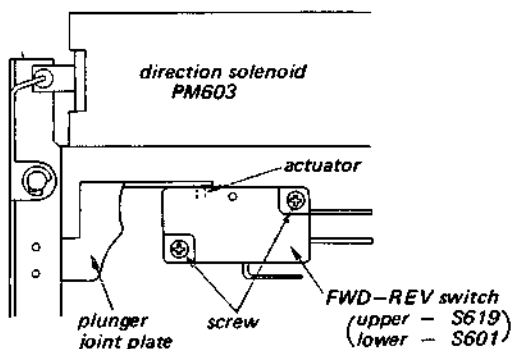

Fig. 3-18. FWD/REV switch (S601, 619) position adjustment

3-1-17. Record Button Block Adjustment

1. See Fig. 3-19. Place the unit in the STOP mode. Check to see that the clearance between the REC button block and the record arm holder is 0.5 (1/64") to 1 mm (3/64"). If necessary, adjust the position of the REC arm holder by loosening the screws.
2. Make sure that the slide switches (S103, 104) on the bias circuit board are perfectly switched, when the REC button is locked. Readjust the clearance between the REC button block and the REC arm holder, if necessary.
3. Apply lock paint to the screws.

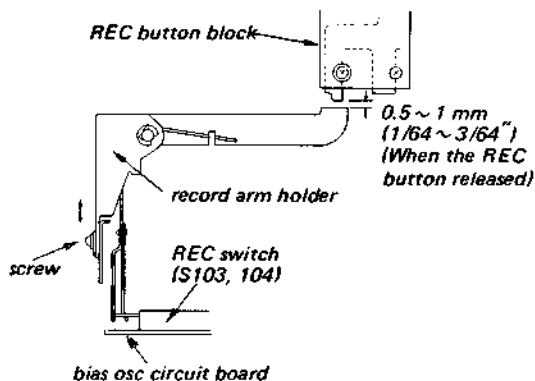

Fig. 3-19. Record button block adjustment

3-1-18. REC Lock Pull Rod Adjustment

1. Place the unit in the STOP mode. Turn the split nut clockwise until the tip of the REC lock pull rod is in contact with the REC lock rod. Moreover, turn the split nut slowly one or two times after the tip of the pull rod is in contact with the REC lock rod. Press the nut by using a pliers.
2. Make sure the followings.
 - a) Lock the REC button in the STOP mode. The REC button is released when the FWD or REV button is pushed.
 - b) Lock the REC button slowly in the STOP mode. The REC lamp lights before the button is locked.
 - c) Lock one of the two REC buttons in the STOP mode. The button is released when another is locked.
3. Apply contact cement to the nut.

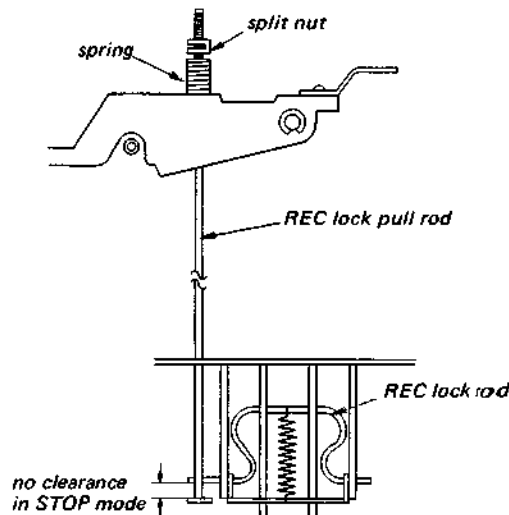

Fig. 3-20. REC lock pull rod adjustment

3-1-19. Equalizer Switch (S107) Position Adjustment

1. Loosen the two screws as shown in Fig. 3-21. Set the tape speed switch to the 9.5 cm/s (center) position.
2. Move the screws so that the equalizer switch is set at the 9.5 cm/s (center) position.
3. Change the tape speed switch to the 4.8 cm/s, 9.5 cm/s and 19 cm/s positions and vice versa several times. Make sure that the equalizer switch is definitely changed.
4. Apply lock paint to the screws.

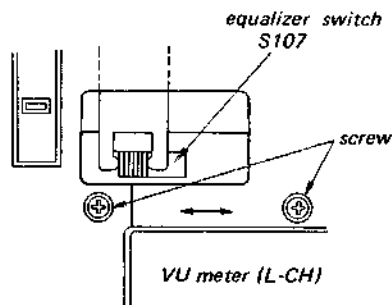

Fig. 3-21. Equalizer switch (S107) position adjustment

3-1-20. PLAY-FF, STOP Switch (S613, 620) Position Adjustment

1. Place the unit in the STOP mode. See Fig. 3-22. Make sure that the distance between the plunger joint plate and the leaf A of the leaf switch is 0 to 0.5 mm (1/64"), and also that the leaves A and B are in contact with each other completely. If necessary, adjust the switch position by loosening the screws.
2. Place the unit in the FWD (or REV) mode, to energize the pinch roller solenoid. Make sure that the leaves A and C are perfectly in contact with each other.
3. Apply lock paint to the screws.

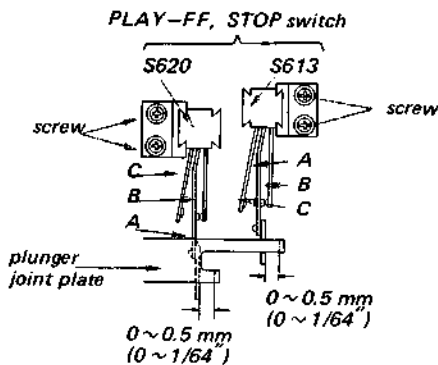

Fig. 3-22. PLAY-FF, STOP switch (S613, 620) position adjustment

3-1-21. PLAY Switch (S615, 616) Position Adjustment

(No adjustment is required for the set having Serial No. 10,551 and later.)

1. Make sure that S615 (S616) is turned ON when the FWD (or REV) button is pushed and also that it is turned OFF when the button is released. If necessary, adjust the position of PLAY switch S615 (or S616) by loosening the

screw A (or screw B) in Fig. 3-23. Make sure that the switch is not turned ON by the play of the FWD button.

2. Apply lock paint to the screws A and B.

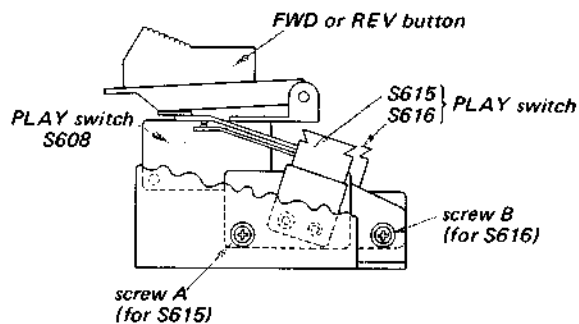

Fig. 3-23. PLAY switch (S615, 616) position adjustment

3-1-22. AUTO OFF Switch (S618) Position Adjustment

1. Place the unit in the FWD or REV mode to energize the pinch roller solenoid (PM601).
2. Loosen the two screws.
3. Adjust the position of PLAY switch so that the distance between the switch and the plate spring is 0 ~ 0.5 mm (1/64").

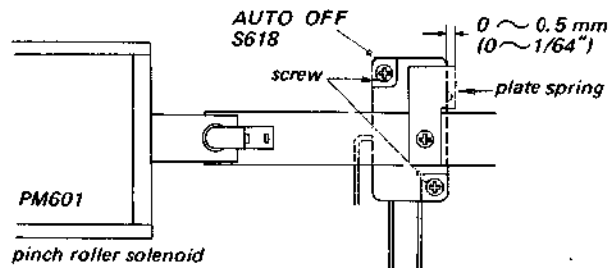

Fig. 3-24. AUTO OFF switch (S618) position adjustment

3-1-23. Adjustments after Head Replacement

For FWD Direction

When replacement of more than two heads is required, leave one of them unremoved for the reference of adjustments. Do not remove all the heads at the same time.

A) Playback Head Replacement

1. Replace the playback head by removing the angle adjusting screws. See Fig. 3-27.

- Do not move the height and zenith adjusting screws.
2. Play back the alignment tape (J-19-A2). Make the azimuth and angle adjustments. See page 28.
 3. Paint the head core with black ink as shown in Fig. 3-25.

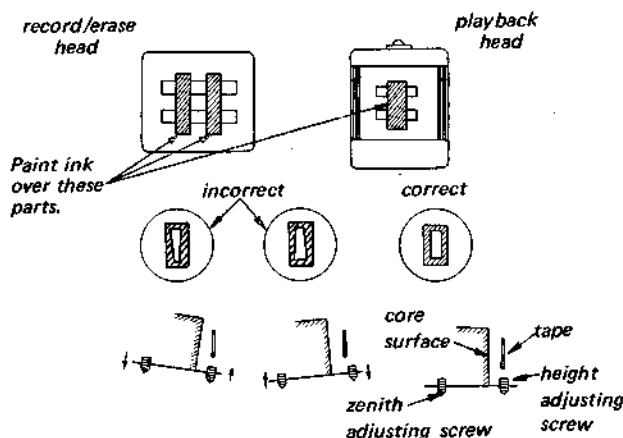

Fig. 3-25. Head zenith and height adjustment

4. After the ink dried, run the tape in the FWD direction for 20 to 30 seconds. Watch the ink on the core fading away. When the same wide amount of the faded away part cannot be obtained at every point, turn the zenith and height adjusting screws in the direction shown by the arrows. See Fig. 3-25. Repeat this step several times until the satisfied result is obtained. After the adjustment clean the core with a soft cloth dampened with denatured alcohol.
5. For the record head tracking adjustment, connect a VTVM and a 100 kΩ resistor in parallel with the LINE OUT jack, deliver the 1 kHz signal (-60 dB) to the MIC jack. Set the MONITOR switch to the TAPE position. Place the unit in a normal stereo record mode. Turn the record head zenith and height adjusting screws in the same amount of the same direction so that the same maximum output can be obtained at both channels.
6. Play back the alignment tape (J-19-A2), and make the playback azimuth adjustment again.

7. Make the playback level and equalizer adjustments. See page 29 and 30.

8. Apply lock paint to the adjusting screws.

B) Record/Erase Head Replacement

1. Remove the azimuth adjusting screw and the head holding screw (with spring). Replace the head with the mounting plate. Do not move the zenith and height adjusting screws.
2. Make the record head azimuth adjustment. See page 30.
3. Paint the record/erase head cores with ink as shown in Fig. 3-25.
4. After the ink dried, run the tape in the FWD direction for 20 to 30 seconds. Watch the ink on the core fading away. When the ink does not fade away in the same wide amount at every point, turn the zenith and height adjusting screws in the direction shown by the arrows. See Fig. 3-25. Repeat this step several times until the satisfied result is obtained. After adjustment clean the cores with a soft cloth dampened with denatured alcohol.
5. Make the record head azimuth adjustment again. See page 30.
6. Make the record head track adjustment. See page 31.
7. Make the record bias adjustment, overall frequency response and erase ratio Measurement.
8. Make sure that the positioning relation between the head core and the tape is correct. See Fig. 3-26.
9. Apply lock paint to the adjusting screws.

For REV Direction

The tape guide (4), which is used for the REV tape path adjustment, should not be adjusted in the head replacement.

The adjustments after playback and record/erase head replacement are the same in procedure as in the FWD head replacement.

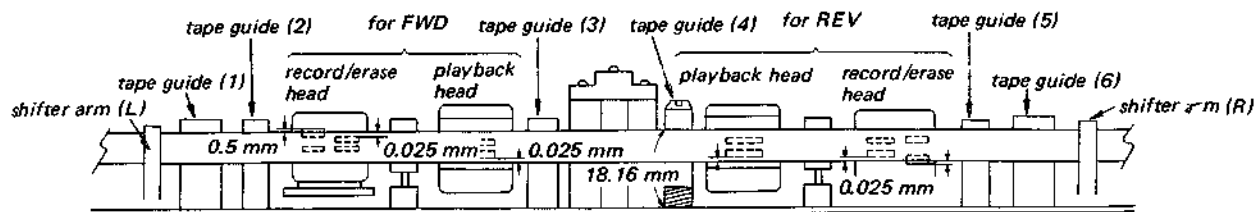

Fig. 3-26. Head adjustment

Checks After Mechanical Adjustment

1. Torque Check

FWD, REV torque more than 200 g. cm
(2.78 oz. inch)

FF, REW torque more than 100 g. cm
(1.39 oz. inch)

FWD, REV back tension
..... 200 – 240 g. cm*
(2.78–3.32 oz. inch)

FF, REW back tension
..... 60 – 80 g. cm*
(0.83–1.1 oz. inch)

* : adjustable

2. After making adjustments, clean the following parts with a soft cloth dampened with denatured alcohol; head core, tape guide, pinch roller, scrape filter roller, brake contact part of the reel table.

3. Tape Contact Check of Scrape Filter Roller

a) Thread a 7-inch tape along the tape path and set the tape speed switch to the 4.8 cm/s position.

b) Run the tape. Make sure that the scrape filter roller is rotating. Stop the roller by fingers. Make sure that the roller starts rotating again when taking off the fingers from the roller. If necessary, adjust the position of the scrape filter roller by loosening the screw.

4. Wow and Flutter Measurement

Make measurements at the beginning and the end of the tape. The measurement may be done with the unit set to either FWD and REV mode.

*At 19 cm/s (7-1/2 ips) and 9.5 cm/s (3-3/4 ips) tape speed

Steps

- (1) Connect a wow meter and a 100-kΩ resistor in parallel with the LINE OUT jack.
- (2) Set the MONITOR switch to TAPE.
- (3) Play back the alignment tape indicated below.
- (4) Make sure that the satisfied result is obtained on the wow meter.

tape speed	specification	remarks
19 cm/s (7-½ ips)	less than 0.12 % (RMS)	Play back SONY alignment tape WS-19-7
9.5 cm/s (3-¾ ips)	less than 0.15 % (RMS)	Play back SONY alignment tape WS-9-7

*At 4.8 cm/s (1-7/8 ips) tape speed

Steps

- (1) Set the record volume controls to the position specified in Precaution (8) on page 25.
- (2) Connect a wow meter and a 100-kΩ resistor in parallel with the LINE OUT jack.
- (3) Set the MONITOR switch to TAPE.
- (4) Deliver a 3-kHz signal of -60 dB (-10 dB) to the MIC (AUX) jack.
- (5) Record the signal on the blank tape.
- (6) Make sure that the satisfied result is obtained on the wow meter.

Specification : less than 0.40 % (RMS)

3-2. ELECTRICAL ADJUSTMENTS

Precaution:

Before making adjustment, make sure to read the following carefully.

(1) Equipment to be required are as follows:

- Audio oscillator (AF OSC)
- Attenuator (ATT)
- VTVM
- Oscilloscope
- Digital frequency counter
- SONY alignment tape
- *J-19-A2 (for head azimuth and angle adj.)
- *J-19-F2 (for 19cm/s level and equalizer adj.)
- *J-9-F1 (for 9.5 cm/s level and equalizer adj.)
- *SPC-47 (for tape speed adj.)
- Fixed resistors
- 600 Ω, 300 Ω, 10 kΩ, 100 kΩ

(2) SONY alignment tapes contain the following information in the sequence indicated.

tone name	1st	2nd	3rd	4th	5th	6th	7th
J-19-A2	12.5 kHz, -10 dB						
J-19-F2	400 Hz	400 Hz	10 kHz	17.5 kHz	7 kHz	80 Hz	40 Hz
	0 dB	-10 dB	10 dB	-10 dB	-10 dB	-10 dB	-10 dB
J-9-F1	5 kHz	400 Hz	400 Hz	5 kHz	3 kHz	200 Hz	80 Hz
	-10 dB	0 dB	-10 dB	-10 dB	-10 dB	-10 dB	-10 dB
SPC-47	4 kHz, 0 dB						

- (3) Make sure to demagnetize the record/erase and playback heads with a soft cloth dampened with denatured alcohol.
- (4) Make sure to demagnetize the record/erase and playback heads by using a head demagnetizer.
- (5) Equipment Connection

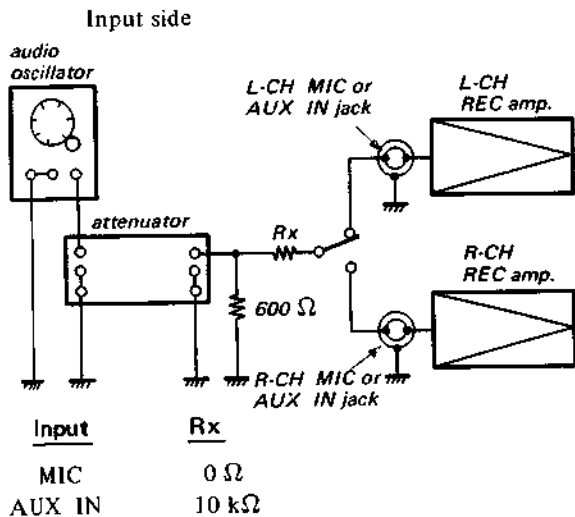

Output side

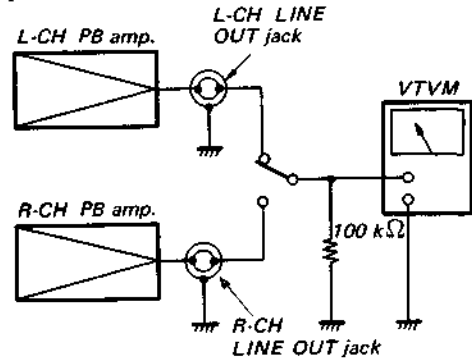

(6) Input and output levels are specified as follows, unless otherwise specified.

Normal input level	MICRO-	
	PHONE	AUX IN
Signal source impedance	300 Ω	10 kΩ
Input signal level	-60 dB (0.775 mV)	-10 dB (0.245 V)

Normal output level

Load resistor	LINE OUT
	100 kΩ
Output level	0 dB (0.775 V)

(7) The switches should be set to the following position, unless otherwise specified.

- *TAPE SPEED — 19cm/s (7½ ips)
- *TAPE SELECT — NORMAL
- *AUTO REV — NON REV

(8) The record volume controls should be set to the following position, unless otherwise specified.

*MIC volume control (In using the MIC jack)
Turn the AUX volume controls fully counter-clockwise, set the MONITOR switch to SOURCE and deliver a 1 kHz signal of -60 dB (0.775 mV) to the MIC jack. Adjust the MIC volume controls so that the VTVM reads 0 dB (0.775 V).

*AUX volume control (In using the AUX IN jack)

Turn the MIC volume controls fully counter-clockwise, set the MONITOR switch to SOURCE and deliver a 1 kHz signal of -10 dB (0.245 V) to the AUX IN jack. Adjust the AUX volume controls so that the VTVM reads 0 dB (0.775 V).

(9) The adjustments should be performed in the sequence, unless otherwise specified.

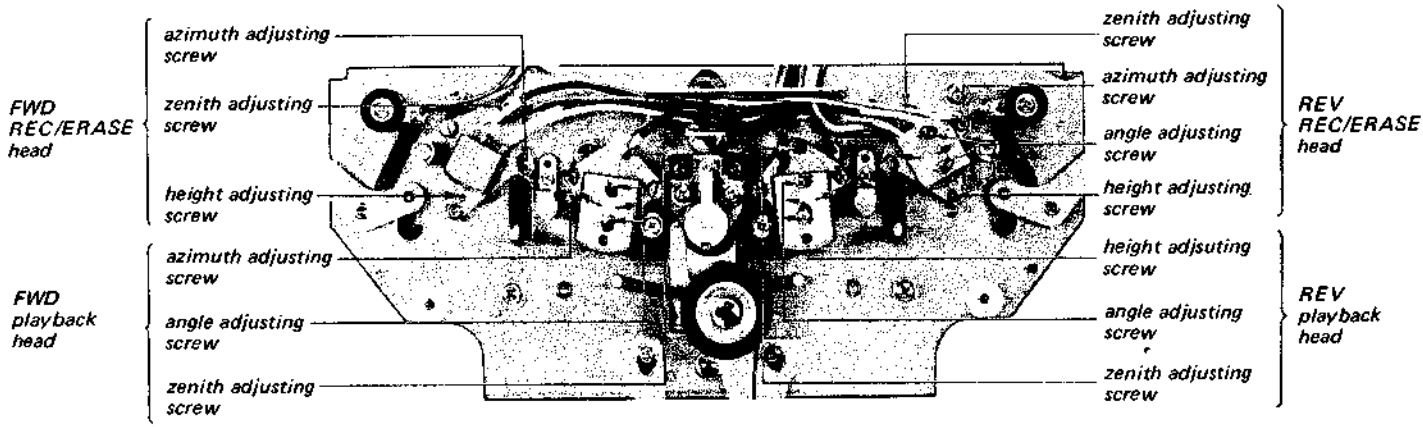

Fig. 3-27. Adjusting parts location (1)

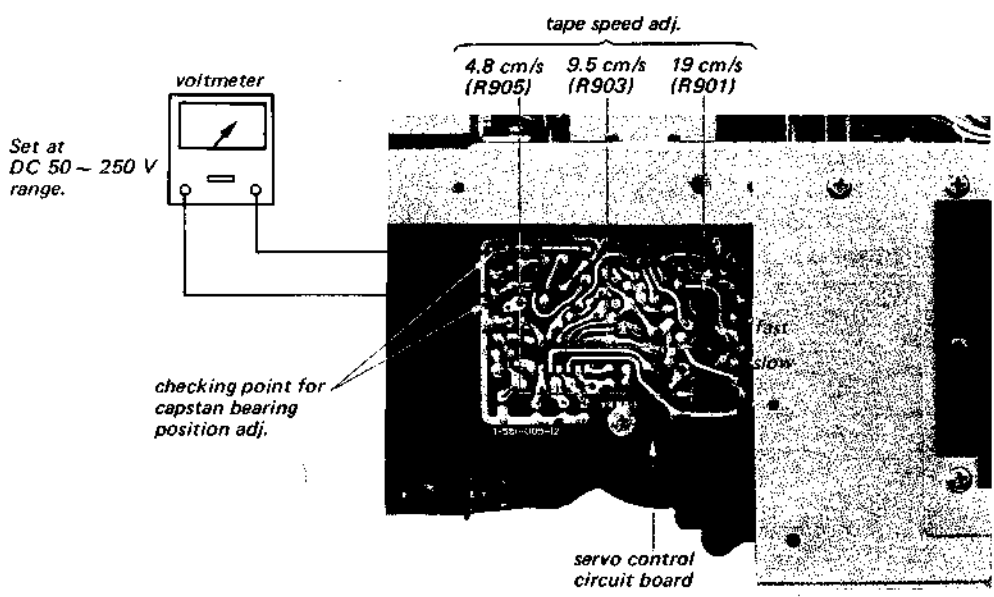

Fig. 3-28. Adjusting parts location (2)

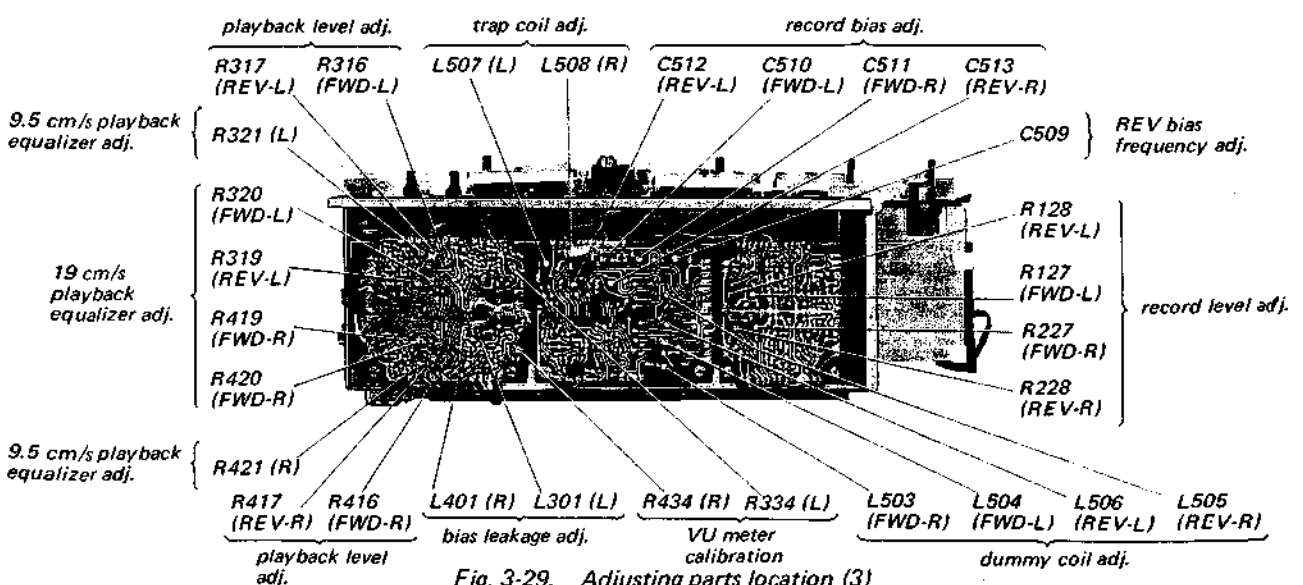
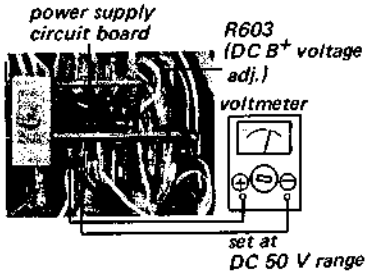
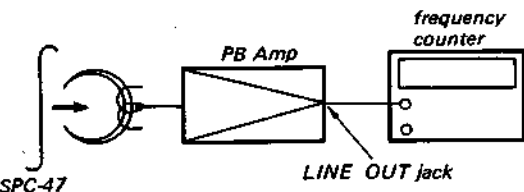
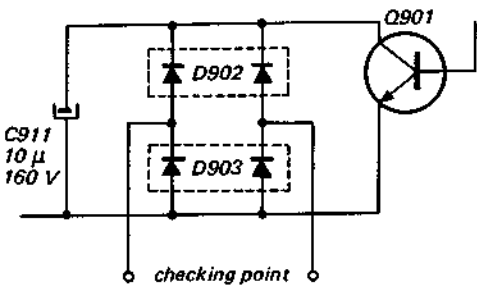
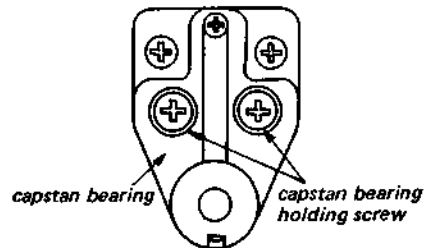
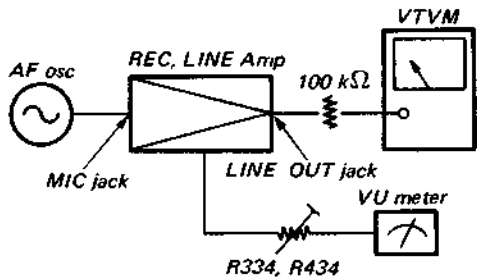
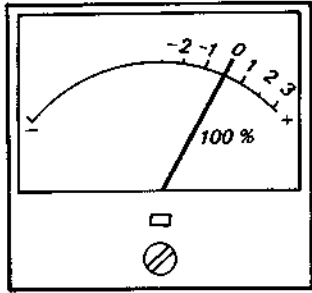
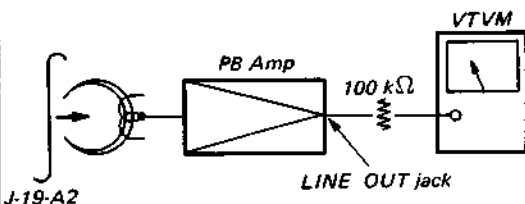
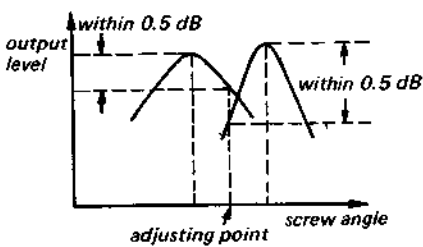
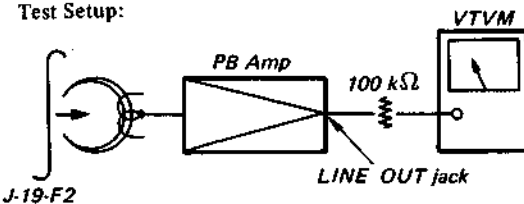
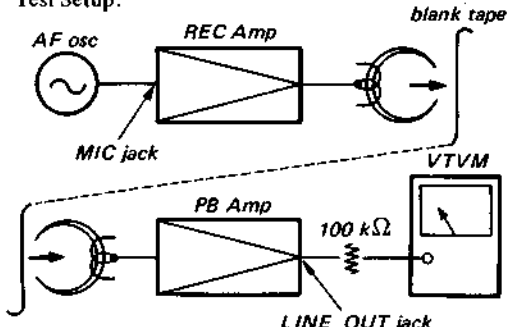
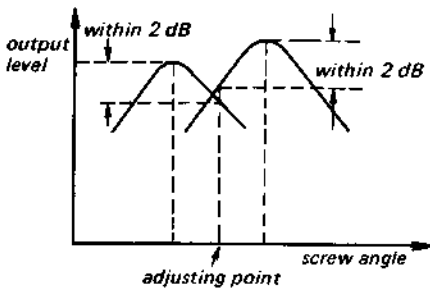

Fig. 3-29. Adjusting parts location (3)

Items	Remarks	Procedures																				
<p>1. DC B⁺ Voltage Adjustment</p>	<p>Test Setup:</p>  <p>Specification: 24 ± 0.5 V</p> <p>Note: Make sure that ac power source voltage is correct.</p>	<p>(1) Place the unit in the STOP mode.</p> <p>(2) Adjust R603 to obtain 24 ± 0.5 V on the voltmeter (20 kΩ/V).</p> <p>CAUTION:</p> <p>Do not short-circuit between B⁺ circuit and ground, or transistor Q602 will be broken.</p>																				
<p>2. Tape Speed Adjustment</p>	<p>Test Setup:</p>  <p>Switch Setting:</p> <p>MONITOR switch TAPE</p> <p>Specifications</p> <table border="1" data-bbox="478 1220 805 1422"> <thead> <tr> <th>tape speed</th> <th>counter reading</th> </tr> </thead> <tbody> <tr> <td>19 cm/s (7-1/2 ips)</td> <td>4000 ± 40 Hz (± 1 %)</td> </tr> <tr> <td>9.5 cm/s (3-3/4 ips)</td> <td>2000 ± 20 Hz (± 1 %)</td> </tr> <tr> <td>4.8 cm/s (1-7/8 ips)</td> <td>1000 ± 20 Hz (± 2 %)</td> </tr> </tbody> </table>	tape speed	counter reading	19 cm/s (7-1/2 ips)	4000 ± 40 Hz (± 1 %)	9.5 cm/s (3-3/4 ips)	2000 ± 20 Hz (± 1 %)	4.8 cm/s (1-7/8 ips)	1000 ± 20 Hz (± 2 %)	<p>(1) Play back the beginning of SONY alignment tape SPC-47 in horizontal position.</p> <p>(2) Adjust R901, R903 and R905 for the counter reading shown in the table below.</p> <table border="1" data-bbox="949 940 1428 1086"> <thead> <tr> <th>tape speed</th> <th>allowable range</th> <th>adjusting parts</th> </tr> </thead> <tbody> <tr> <td>19 cm/s (7-1/2 ips)</td> <td>4000 Hz ± 5 Hz</td> <td>R901 10 kΩ (B)</td> </tr> <tr> <td>9.5 cm/s (3-3/4 ips)</td> <td>2000 Hz ± 3 Hz</td> <td>R903 20 kΩ (B)</td> </tr> <tr> <td>4.8 cm/s (1-7/8 ips)</td> <td>1000 Hz ± 2 Hz</td> <td>R905 50 kΩ (B)</td> </tr> </tbody> </table> <p>(3) Make sure that the specifications shown in left table is satisfied at the beginning and end of tape in forward and reverse mode, with the unit placed in both horizontal and vertical position.</p> <p>Note: Take the reading of a frequency counter after more than 5 seconds since the semi-fixed resistor has been finished to turn.</p>	tape speed	allowable range	adjusting parts	19 cm/s (7-1/2 ips)	4000 Hz ± 5 Hz	R901 10 kΩ (B)	9.5 cm/s (3-3/4 ips)	2000 Hz ± 3 Hz	R903 20 kΩ (B)	4.8 cm/s (1-7/8 ips)	1000 Hz ± 2 Hz	R905 50 kΩ (B)
tape speed	counter reading																					
19 cm/s (7-1/2 ips)	4000 ± 40 Hz (± 1 %)																					
9.5 cm/s (3-3/4 ips)	2000 ± 20 Hz (± 1 %)																					
4.8 cm/s (1-7/8 ips)	1000 ± 20 Hz (± 2 %)																					
tape speed	allowable range	adjusting parts																				
19 cm/s (7-1/2 ips)	4000 Hz ± 5 Hz	R901 10 kΩ (B)																				
9.5 cm/s (3-3/4 ips)	2000 Hz ± 3 Hz	R903 20 kΩ (B)																				
4.8 cm/s (1-7/8 ips)	1000 Hz ± 2 Hz	R905 50 kΩ (B)																				
<p>3. Capstan Bearing Position Adjustment</p>	<p>Test Setup:</p>  <p>Specification:</p> <p>voltmeter reading maximum</p>	<p>(1) Place the unit in the STOP mode.</p> <p>(2) Loosen the two capstan bearing holding screws.</p> <p>(3) Adjust the position of the capstan bearing so that the voltmeter reads a maximum.</p> <p>(4) Tighten the screws and apply lock paint to the screws.</p> <p>(See Fig. 3-1)</p> 																				

Items	Remarks	Procedures
<p>4. VU Meter Calibration</p>	<p>Test Setup:</p>  <p>Switch Setting: MONITOR switch SOURCE</p> <p>Specification: 0 ± 0.5 on the VU meter scale when the line output is 0 dB (0.775 V).</p>	<ol style="list-style-type: none"> Deliver a 1 kHz signal of -60 dB (0.775 mV) to the MIC jack. Place the unit in the stereo-record mode. Adjust the MIC volume control for 0 dB (0.775 V) on the VTVM. Adjust R334 and R434 so that the pointer of VU meter stays at 0 ± 0.5 VU on the meter. When changing the frequency from 1 kHz to 100 Hz and 10 kHz, make sure that the VU meter reads between -1 and +1 on the meter. <p style="text-align: center;">VU meter</p> 
<p>5. Playback Head Azimuth and Angle Adjustment</p>	<p>Test Setup:</p>  <p>Switch Setting: MONITOR switch TAPE</p> <p>Specification: Screw position where the maximum output is obtained.</p> <p>Notes:</p> <ol style="list-style-type: none"> Before the adjustment, make sure that the head comes in contact with the tape normally in forward mode. 	<ol style="list-style-type: none"> Play back the SONY alignment tape J-19-A2 (12.5 kHz). Adjust the playback head azimuth adjusting screw for the maximum output on the VTVM. <p>Note: If the maximum value for both channels can not be obtained at the same angle of the screw, take the mid between the two angles and make sure that the difference between the output obtained by turning the screw from the maximum output position and the each maximum output is within 0.5 dB.</p> <ol style="list-style-type: none"> Loosen the playback head angle adjusting screws. Slightly, hold the supply reel table by the hand. Adjust by moving the playback head in the direction shown by the arrows (See Fig. 3-26) so that the level fluctuation is the least at the maximum output and the playback output does not increase more than 0.5 dB. Repeat the above steps (1) and (2). Apply lock paint to the azimuth and angle adjusting screws. 

Items	Remarks	Procedures																																										
<p>6. Playback Level Adjustment</p>	<p>Test Setup:</p>  <p>Switch Setting: MONITOR switch TAPE</p> <p>Specification: 0 dB (0.775 V) NORMAL -2.5 ~ -1.5 dB against NORMAL SPECIAL</p> <p>Note: The adjustment should be performed for both L-CH and R-CH in forward and reverse modes.</p>	<p>(1) Set the TAPE SELECT switch to NORMAL.</p> <p>(2) Play back the 1st tone (400 Hz, 0 dB) of the SONY alignment tape J-19-F2.</p> <p>(3) Adjust R316, R317, R416 and R417 for 0 dB (0.775 V) on the VTVM.</p> <p style="padding-left: 40px;">R316 (L-CH forward run) R416 (R-CH forward run) R317 (L-CH reverse run). R417 (R-CH reverse run)</p> <p>(4) When changing the TAPE SELECT switch to SPECIAL, make sure that the VTVM reads between -2.5 dB and -1.5 dB (0.58 V and 0.64 V).</p>																																										
<p>7. Playback Equalizer Adjustment</p>	<p>Test Setup: Same as Item 7</p> <p>Switch Setting: MONITOR switch TAPE</p> <p>Specification: Deviation against 400 Hz of 2nd tone</p> <table border="1" data-bbox="367 1220 885 1377"> <caption>at 19 cm/s tape speed with J-19-F2</caption> <thead> <tr> <th>tape tone</th> <th>3rd</th> <th>4th</th> <th>5th</th> <th>6th</th> <th>7th</th> </tr> </thead> <tbody> <tr> <td>frequency</td> <td>10 kHz</td> <td>12.5 kHz</td> <td>7 kHz</td> <td>80 Hz</td> <td>40 Hz</td> </tr> <tr> <td rowspan="2">output level</td> <td>L</td> <td>± 2 dB</td> <td>± 2 dB</td> <td>± 3 dB</td> <td>+ 5 dB</td> </tr> <tr> <td>R</td> <td>± 2 dB</td> <td>± 2 dB</td> <td>+ 1 dB</td> <td>0 dB</td> </tr> </tbody> </table> <p>Deviation against 400 Hz of 3rd tone</p> <table border="1" data-bbox="367 1534 837 1713"> <caption>at 9.5 cm/s tape speed with J-9-F1</caption> <thead> <tr> <th>tape tone</th> <th>4th</th> <th>5th</th> <th>6th</th> <th>7th</th> </tr> </thead> <tbody> <tr> <td>frequency</td> <td>5 kHz</td> <td>3 kHz</td> <td>200 Hz</td> <td>80 Hz</td> </tr> <tr> <td rowspan="2">output level</td> <td>L</td> <td>± 2 dB</td> <td>± 2 dB</td> <td>± 2 dB</td> </tr> <tr> <td>R</td> <td>± 2 dB</td> <td>± 2 dB</td> <td>± 2 dB</td> </tr> </tbody> </table> <p>Notes:</p> <ol style="list-style-type: none"> First, 19cm/s (7-1/2 ips) equalizer adjustment should be performed. The adjustment should be performed for both L-CH and R-CH in forward and reverse modes. Level difference between the forward and reverse modes should be within 1 dB. 	tape tone	3rd	4th	5th	6th	7th	frequency	10 kHz	12.5 kHz	7 kHz	80 Hz	40 Hz	output level	L	± 2 dB	± 2 dB	± 3 dB	+ 5 dB	R	± 2 dB	± 2 dB	+ 1 dB	0 dB	tape tone	4th	5th	6th	7th	frequency	5 kHz	3 kHz	200 Hz	80 Hz	output level	L	± 2 dB	± 2 dB	± 2 dB	R	± 2 dB	± 2 dB	± 2 dB	<p>(1) Set the TAPE SPEED switch to 19cm/s (7-1/2 ips).</p> <p>(2) Play back the 2nd (400 Hz) and 3rd (10 kHz) tones of SONY alignment tape J-19-F2.</p> <p>(3) Adjust R319, R320, R419 and R420 so that the playback output of the 3rd tone is the same as that of the 2nd tone.</p> <p style="padding-left: 40px;">R319 (L-CH forward run) R419 (R-CH forward run) R320 (L-CH reverse run) R420 (R-CH reverse run)</p> <p>(4) Play back the 4th (12.5 kHz), 5th (7 kHz), 6th (80 Hz) and 7th (40 Hz) tones of SONY alignment tape J-19-F2 in order.</p> <p>(5) Make sure that the each deviation against 400 Hz of 2nd tone is within specification shown in the left table.</p> <p>(6) Set the TAPE SPEED switch to 9.5cm/s (3-3/4 ips).</p> <p>(7) Play back the 3rd (400 Hz) and 4th (5 kHz) tones of SONY alignment tape J-9-F1.</p> <p>(8) Adjust R321 and R421 so that the playback output of the 4th tone is the same as that of 3rd tone.</p> <p style="padding-left: 40px;">R321 (L-CH forward run) R421 (R-CH forward run)</p> <p>(9) Play back the 5th (3 kHz), 6th (200 Hz) and 7th (80 Hz) tones of SONY alignment tape J-9-F1 in order.</p> <p>(10) Make sure that the each deviation against 3rd (400 Hz) tone is within ±2 dB as shown in the left table.</p>
tape tone	3rd	4th	5th	6th	7th																																							
frequency	10 kHz	12.5 kHz	7 kHz	80 Hz	40 Hz																																							
output level	L	± 2 dB	± 2 dB	± 3 dB	+ 5 dB																																							
	R	± 2 dB	± 2 dB	+ 1 dB	0 dB																																							
tape tone	4th	5th	6th	7th																																								
frequency	5 kHz	3 kHz	200 Hz	80 Hz																																								
output level	L	± 2 dB	± 2 dB	± 2 dB																																								
	R	± 2 dB	± 2 dB	± 2 dB																																								

Items	Remarks	Procedures
<p>8. Record Head Azimuth and Angle Adjustment</p>	<p>Test Setup:</p>  <p>Control/Switch Setting:</p> <ul style="list-style-type: none"> *Record volume control specified position on page 25 *MONITOR switch TAPE <p>Specification:</p> <ul style="list-style-type: none"> *Screw position where the maximum output is obtained. 	<ol style="list-style-type: none"> (1) Deliver a 15 kHz of -80 dB (77.5 μV) to the MIC jack. (2) Place the unit in the forward (reverse) mode. (3) Adjust the record head azimuth adjusting screw for the maximum output on the VTVM. <p>Note: If the screw is turned more than 1 turn, make the record head track adjustment again.</p> <p>The maximum value for both channels can not be obtained at the same angle of the screw, take the mid between the two angles and make sure that the difference between the output obtained by turning the screw from the maximum output position and the each maximum output is within 2 dB.</p> <ol style="list-style-type: none"> (4) Slightly, hold the supply reel table by the hand. (5) Make sure that the playback output does not increase more than 3 dB. If not, adjust by moving the record head in the direction shown by the arrows (See Fig. 3-26) so that the level fluctuation is the least at the maximum output. (6) Apply lock paint to the azimuth and angle adjusting screws. 

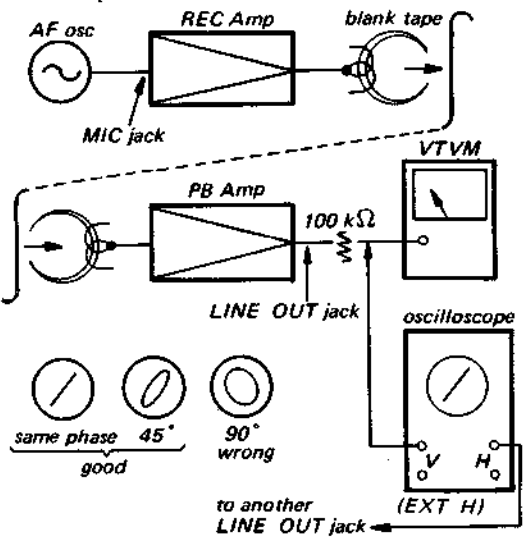
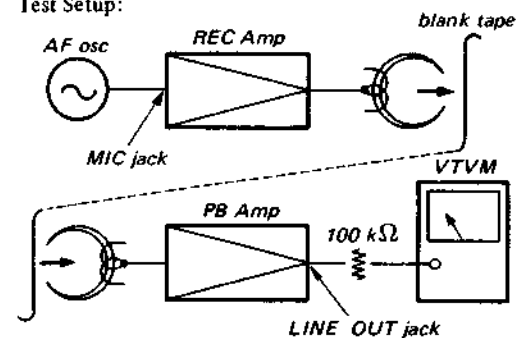
Items	Remarks	Procedures
<p>9. Record Head Track Adjustment</p>	<p>Test Setup:</p>  <p>Control/Switch Setting:</p> <ul style="list-style-type: none"> *Record volume control specified position on page 25 *MONITOR switch TAPE <p>Specification:</p> <ul style="list-style-type: none"> *Lissajous figure on scope within 45° *Playback output maximum <p>Notes:</p> <ol style="list-style-type: none"> (1) Before the adjustment, make sure that the height of head is normal against the tape in the forward mode. (2) Perform this adjustment after that for the playback head was done. 	<ol style="list-style-type: none"> (1) Thread a blank tape. (2) Place the unit in the record mode. (3) Deliver a 1 kHz signal of -60 dB (0.775 mV) to the MIC jack. (4) Adjust the record head azimuth adjusting screw so that the lissajous figure on the scope is within 45° (5) Carefully noting how many turns the screw is turned, adjust the record head height adjusting screw for the maximum output on the VTVM. (6) Turn the record head zenith adjusting screw in the same direction by the same turns as noted in the above step (5). <p>Note: If the maximum value for both channels can not be obtained at the same angle of the screw, take the mid between the two angles and then make sure that the level difference from the each maximum value is less than 1 dB.</p> <ol style="list-style-type: none"> (7) Check the record head azimuth adjustment.
<p>10. Dummy Coil Adjustment</p>	<p>Test Setup:</p>  <p>Control/Switch Setting:</p> <ul style="list-style-type: none"> *Record volume control Specified position on page 25 *MONITOR switch TAPE 	<ol style="list-style-type: none"> (1) Thread a blank tape. (2) Deliver a 20 kHz signal of -80 dB (77.5 μV) to the MIC jack. (3) Place the unit in the stereo-record mode. (4) Note the VTVM reading. (5) Place only L-CH in the record mode. (6) Adjust L504 slowly so that the VTVM reading is the same as the value obtained in the step 4. <p style="text-align: right;"> L504 (L-CH forward run) L503 (R-CH forward run) L506 (L-CH reverse run) L505 (R-CH reverse run) </p>

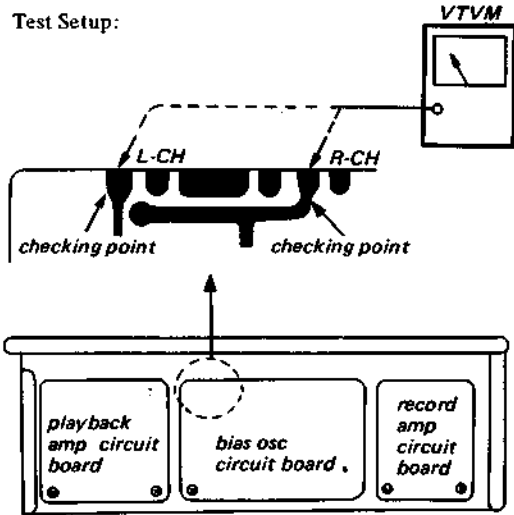
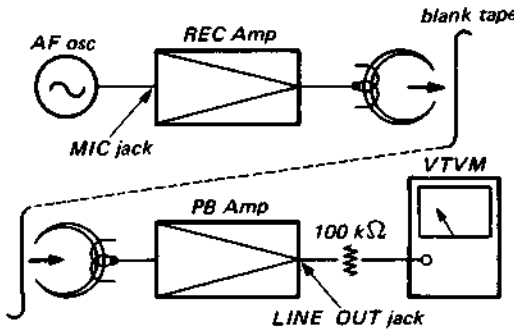
Items	Remarks	Procedures
<p>11. Reverse Bias Frequency Adjustment</p>	<p>Test Setup:</p>  <p>Control Setting: Record volume control fully counterclockwise</p> <p>Specification: Less than -10 dB</p> <p>Note: Perform after the trap coil adjustment.</p>	<ol style="list-style-type: none"> Place the unit in the reverse-stereo record mode. Adjust C509 so that the VTVM reads a minimum (less than -10 dB). <p>Note: If the minimum value for both channels can not be obtained at the same angle of the trimmer capacitor, take the mid between the two angles.</p> <p>After the adjustment, make sure that the VTVM reads less than -10 dB.</p> <ol style="list-style-type: none"> Apply lock paint to the trimmer capacitor.
<p>12. Record Bias Adjustment</p>	<p>Test Setup:</p>  <p>Control/Switch Setting: *Record volume control specified position on page 25 *MONITOR switch TAPE</p> <p>Specification: *0 +1 dB at peak bias point *0 ± 2 dB playback output of 18 kHz signal against that of 1 kHz signal</p> <p>Note: The adjustment should be performed for both L-CH and R-CH in forward and reverse modes.</p>	<ol style="list-style-type: none"> Turn C510, C511, C512 and C513 clockwise to the full and return them approximately three times. Thread a blank tape. Deliver a 1 kHz signal of -80 dB (77.5 μV) to the MIC jack. Place the unit in the stereo-record mode. Slowly, turn C510, C511, C512 and C513 clockwise, and the VTVM reading will go up and reach a maximum. <p>So note the VTVM reading.</p> <p>C510 (L-CH forward run) C511 (R-CH forward run) C512 (L-CH reverse run) C513 (R-CH reverse run)</p> <ol style="list-style-type: none"> Change the input signal frequency from 1 kHz to 18 kHz. Turn C510, C511, C512 and C513 further clockwise so that the VTVM reading is the same as the value noted in the step (5). <p>Note: Make sure that the VTVM reading does not fall more than 1 dB from the maximum output obtained in the step (5).</p> <ol style="list-style-type: none"> Apply lock paint to the trimmer capacitors.

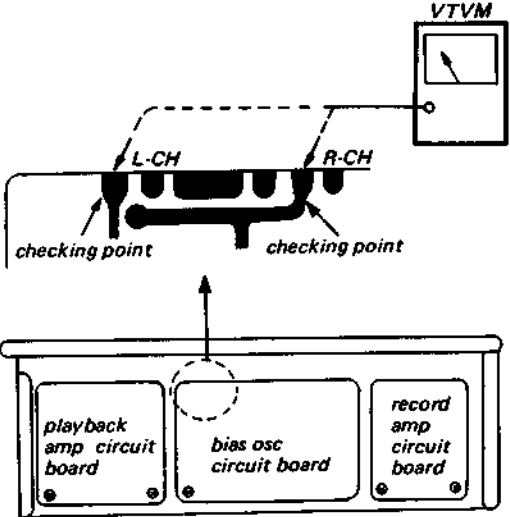
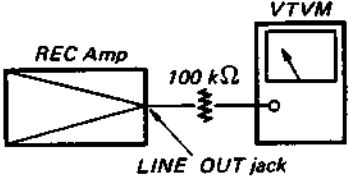
Items	Remarks	Procedures
<p>13. Trap Coil and Bias Leakage Adjustment</p>	<p>Test Setup:</p> <p>A) Trap coil adjustment</p>  <p>B) Bias leakage adjustment</p>  <p>Specification:</p> <p>Less than -10 dB (Trap Coil Adjustment)</p> <p>Less than -35 dB (Bias Leakage Adjustment)</p> <p>Notes:</p> <p>(1) Use a non-metallic screwdriver.</p> <p>(2) Do not use shielded wire as the lead of the VTVM.</p>	<p>A) Trap Coil Adjustment</p> <ol style="list-style-type: none"> (1) Set the record volume control (MIC and AUX) counterclockwise to the full. (2) Place the unit in the stereo-record mode. (3) Adjust L507 and L508 so that the VTVM connected between the checking point and ground reads a minimum (less than -10 dB). <p>B) Bias Leakage Adjustment</p> <ol style="list-style-type: none"> (1) Set the record volume control (MIC and AUX) clockwise to the full. (2) Place the unit in the stereo-record mode. (3) Set the MONITOR switch to TAPE. (4) Adjust L301 and L401 so that the VTVM reads a minimum (less than -35 dB). (5) Change the MONITOR switch to SOURCE and make sure that the VTVM reads less than -35 dB. <p style="text-align: right;">L301 (L-CH forward run) L401 (R-CH forward run)</p>

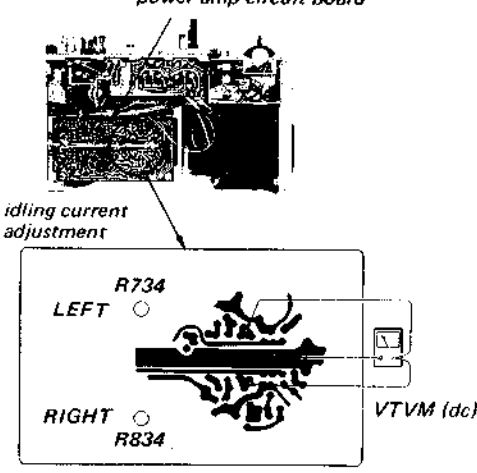
Items	Remarks	Procedures
<p>14. Record Level Adjustment</p>	<p>Test Setup: Same as Item 13</p> <p>Control/Switch Setting: Record volume control specified position on page 25</p> <p>MONITOR switch TAPE</p> <p>Specification:</p> <p>0 ± 1 dB Playback output at 19 cm/s (7-1/2 ips) tape speed</p> <p>0 ± 2 dB Playback output at 9.5 cm/s (3-3/4 ips) and 4.8 cm/s (1-7/8 ips) tape speed</p> <p>* The level difference between channels at 9.5 cm/s and 4.8 cm/s tape speed within 2 dB</p> <p>* The level difference between stereo-record mode and monaural-record mode within 1 dB</p> <p>Note: The adjustment should be performed for both L-CH and R-CH in forward and reverse modes.</p>	<p>(1) Deliver a 1 kHz signal of -60 dB (0.775 mV) to the MIC jack.</p> <p>(2) Set the TAPE SPEED switch to 19 cm/s (7-½ ips).</p> <p>(3) Place the unit in the stereo-record mode.</p> <p>(4) Adjust R127, R128, R227 and R228 so that the VTVM reads 0 ± 1 dB.</p> <p style="padding-left: 40px;">R127 (L-CH forward run) R227 (R-CH forward run) R128 (L-CH reverse run) R228 (R-CH reverse run)</p> <p>(5) When changing the TAPE SPEED switch to 9.5 cm/s (3-3/4 ips) and 4.8 cm/s (1-7/8 ips) make sure that the VTVM reads 0 ± 2 dB and that the difference between L-CH and R-CH is within 2 dB.</p> <p>(6) When changing a mode from stereo to monaural, make sure that difference between them is within 1 dB.</p>
<p>15. Idling Current Adjustment</p>	<p>Test Setup: <i>power amp circuit board</i></p>  <p><i>idling current adjustment</i></p> <p>Specification: Voltage at checking point 20 mV</p> <p>Note: Adjust as soon as possible since the POWER AMP switch is set to ON.</p>	<p>(1) Set the POWER AMP switch to ON.</p> <p>(2) Adjust R734 and R834 to obtain 20 mV on the VTVM.</p>

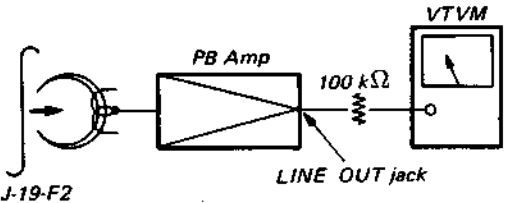
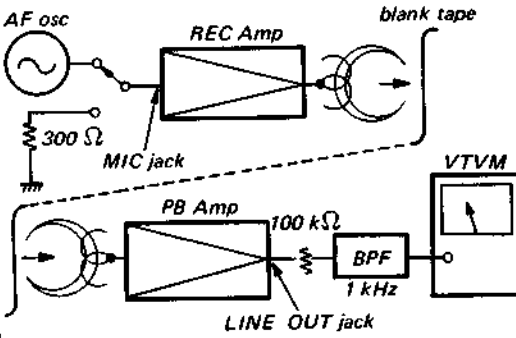
Items	Remarks	Procedures
<p>16. Playback S/N Ratio Measurement</p>	<p>Test Setup:</p>  <p>Switch Setting:</p> <p>MONITOR switch TAPE</p> <p>Specification:</p> <p>more than 48 dB in both FWD and REV modes</p>	<ol style="list-style-type: none"> (1) Play back the 1st tone (400 Hz) of SONY alignment tape (J-19-F2). (2) Note the VTVM reading. (3) Remove the alignment tape. (4) Hold the both actuators so that the shut-off switch is activated (a rubber band or piece of masking tape will hold the actuator as though tape were threaded on the unit). (5) Place the unit in the FWD or REV mode without the tape threaded. (6) Note the VTVM reading. (7) Make sure that the level difference between step (2) and step (6) is more than 48 dB. (8) Reverse the power plug to the AC outlet and repeat the step (1) through the step (6). (9) Make sure that the level difference is also more than 48 dB.
<p>17. Erase Ratio Measurement</p>	<p>Test Setup:</p>  <p>Control/Switch Setting:</p> <p>*Record volume control specified position on page 25</p> <p>*MONITOR switch TAPE</p> <p>Specification:</p> <p>*Erase ratio more than 60 dB</p> <p>*Level fluctuation width within 5 dB</p>	<ol style="list-style-type: none"> (1) Thread a blank tape. (2) Deliver a 1 kHz signal of -50 dB (2.45 mV) to the MIC jack. (3) Record the signal on the tape, noting where the reading begins for a later reference. (4) Disconnect the audio oscillator. (5) Rewind a half of the recorded tape. (6) Terminate the MIC jack with a 300 Ω resistor. (7) Erase the tape by recording with no input signal. (8) Rewind again to the beginning of the recording. (9) Place the unit in the playback mode. (10) Play back the tape, reading the VTVM, and make sure that the difference between the two parts is more than 60 dB, and that the level fluctuation width is within 5 dB. If not, check the tape path adjustment.

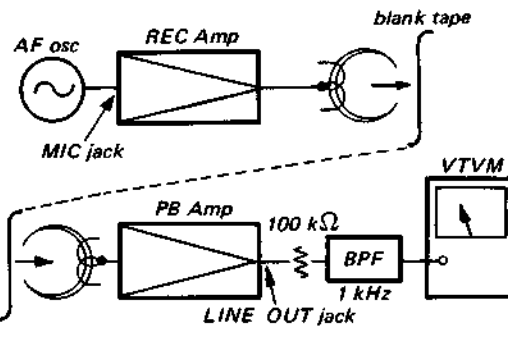
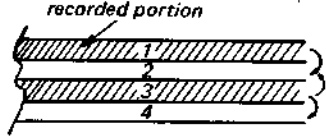
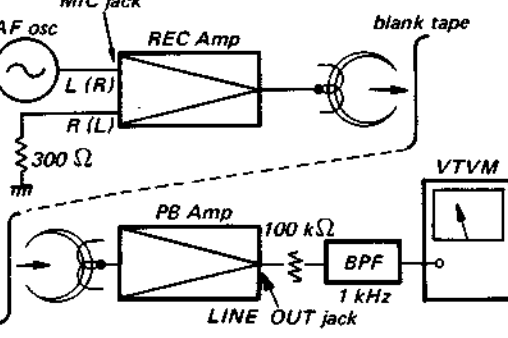
Items	Remarks	Procedures
18. Crosstalk Measurement (between tracks)	<p>Test Setup:</p>  <p>Control/Switch Setting:</p> <ul style="list-style-type: none"> *Record volume control specified position on page 25 *MONITOR switch TAPE <p>Specification:</p> <p>more than 60 dB</p> <p>Note: Use a well-demagnetized tape or a new tape.</p>	<ol style="list-style-type: none"> (1) Deliver a 1 kHz signal of -50 dB (2.45 mV) to the MIC jack. (2) Record the signal on the tape in the stereo record mode. (3) Note the VTVM reading. (4) Invert and reverse the reels. (5) Play back the tape. (6) Measure the VTVM reading at both L-CH and R-CH LINE OUTputs. (7) Make sure that the difference between the step (3) and the step (6) is more than 60 dB. 
19. Crosstalk Measurement (between channels)	<p>Test Setup:</p>  <p>Control/Switch Setting:</p> <p>Same as Item 18</p> <p>Specification:</p> <p>more than 45 dB</p> <p>Note: Use a well-demagnetized tape or a new tape.</p>	<ol style="list-style-type: none"> (1) Thread a blank tape. (2) Terminate the R-CH (L-CH) MIC jack with a 300 Ω resistor. (3) Deliver a 1 kHz signal of -50 dB (2.45 mV) to the L-CH (R-CH) MIC jack. (4) Place the unit in the stereo-record mode. (5) Make sure that the level difference between L-CH and R-CH is more than 45 dB.

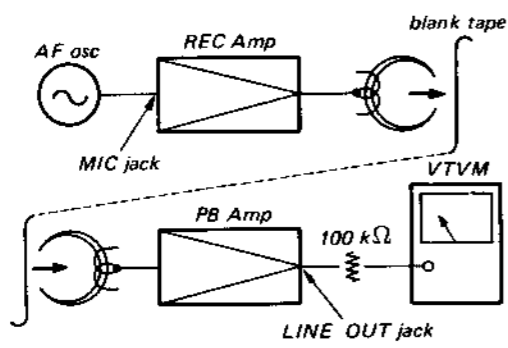
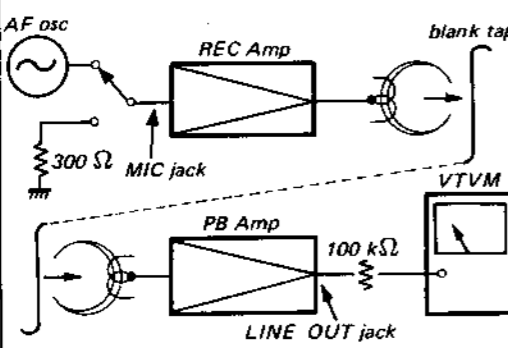
Items	Remarks	Procedures																																
20. Overall Frequency Response Measurement	<p>Test Setup:</p>  <p>Control/Switch Setting:</p> <p>*Record volume control specified position on page 25</p> <p>*MONITOR switch TAPE</p> <p>*TAPE SELECT switch SPECIAL (with a SONY SLH tape) NORMAL (with a standard tape)</p> <p>Specification:</p> <table border="1"> <thead> <tr> <th>speed freq.</th> <th>19 cm/s</th> <th>9.5 cm/s</th> <th>4.8 cm/s</th> </tr> </thead> <tbody> <tr> <td>50 Hz</td> <td>± 3 dB</td> <td>+ 3/6 dB</td> <td>+ 3/3 dB</td> </tr> <tr> <td>100 Hz</td> <td>± 3 dB</td> <td>± 3 dB</td> <td>± 3 dB</td> </tr> <tr> <td>5 kHz</td> <td>± 3 dB</td> <td>± 3 dB</td> <td>+ 3/6 dB</td> </tr> <tr> <td>7 kHz</td> <td>± 3 dB</td> <td>± 3 dB</td> <td>-</td> </tr> <tr> <td>10 kHz</td> <td>-</td> <td>+ 3/3 dB</td> <td>-</td> </tr> <tr> <td>12.5 kHz</td> <td>± 3 dB</td> <td>+ 7/10 dB</td> <td>-</td> </tr> <tr> <td>18 kHz</td> <td>NORMAL + 3/6 dB SPECIAL ± 3 dB</td> <td>-</td> <td>-</td> </tr> </tbody> </table>	speed freq.	19 cm/s	9.5 cm/s	4.8 cm/s	50 Hz	± 3 dB	+ 3/6 dB	+ 3/3 dB	100 Hz	± 3 dB	± 3 dB	± 3 dB	5 kHz	± 3 dB	± 3 dB	+ 3/6 dB	7 kHz	± 3 dB	± 3 dB	-	10 kHz	-	+ 3/3 dB	-	12.5 kHz	± 3 dB	+ 7/10 dB	-	18 kHz	NORMAL + 3/6 dB SPECIAL ± 3 dB	-	-	<ol style="list-style-type: none"> Set the TAPE SPEED switch to 19 cm/s (7-1/2 ips). Thread a blank tape. Deliver a 1 kHz signal of -80 dB (77.5 μV) to the MIC jack. Place the unit in the record mode. Note the VTVM reading. Change the frequency of an audio oscillator to 50 Hz, 100 Hz, 5 kHz, 7 kHz, 10 kHz, 12.5 kHz and 18 kHz in order and note the VTVM reading. Make sure that the level deviation of each frequency against 1 kHz signal is within the range specified. Repeat the above steps (3) through (7) at the tape speed of 9.5 cm/s (3 3/4 ips) and 4.8 cm/s (1 7/8 ips).
speed freq.	19 cm/s	9.5 cm/s	4.8 cm/s																															
50 Hz	± 3 dB	+ 3/6 dB	+ 3/3 dB																															
100 Hz	± 3 dB	± 3 dB	± 3 dB																															
5 kHz	± 3 dB	± 3 dB	+ 3/6 dB																															
7 kHz	± 3 dB	± 3 dB	-																															
10 kHz	-	+ 3/3 dB	-																															
12.5 kHz	± 3 dB	+ 7/10 dB	-																															
18 kHz	NORMAL + 3/6 dB SPECIAL ± 3 dB	-	-																															
21. Overall S/N Ratio Measurement	<p>Test Setup:</p>  <p>Control/Switch Setting:</p> <p>*Record volume control specified position on page 25</p> <p>*MONITOR switch TAPE</p>	<ol style="list-style-type: none"> Thread a blank tape. Deliver a 1 kHz signal of -60 dB (0.775 mV) to the MIC jack. Place the unit in the record mode. Record the signal on the tape, noting where the recording begins for a later reference. Disconnect the audio oscillator. Rewind a half of the recorded tape. Terminate the MIC jack with a 300 Ω resistor. Place the unit in the record mode with no input signal. Make sure that the difference between two parts is within the specification. 																																

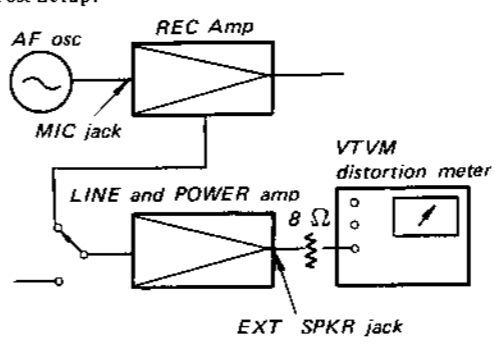
Items	Remarks	Procedures
Overall S/N Ratio Measurement	<p>Specification:</p> <p>*more than 45 dB at 19 cm/s tape speed</p> <p>*more than 41 dB at both 9.5 cm/s and 4.8 cm/s tape speed.</p>	
22. Maximum Output and Distortion Measurement	<p>Test Setup:</p>  <p>Control/Switch Setting:</p> <p>TREBLE, BASS and BALANCE controls mechanical mid</p> <p>MONITOR switch source</p> <p>POWER AMP switch ON</p> <p>SPKR SELECT switch EXT SP</p> <p>TAPE SELECT switch NORMAL</p> <p>TAPE SPEED switch 19 cm/s</p> <p>Specification:</p> <p>*Maximum output .. greater than +23dB (15 W)</p> <p>*Distortion less than 1% (with power amp output of 17 dB)</p>	<p>A) Maximum Output Measurement</p> <ol style="list-style-type: none"> Deliver a 1 kHz signal of -60 dB (0.775 mV) to the MIC jack. Place the unit in the record mode. Adjust the MIC volume control (R135, 235) to obtain 0 dB (0.775 V) on the VTVM. Turn the VOLUME control (R708, 808) fully clockwise. Measure the output level with the VTVM. <p>B) Distortion Measurement</p> <ol style="list-style-type: none"> Perform steps (1) through (3) of the above procedure. Adjust the VOLUME control to obtain 17 dB (5.49 V) on the VTVM. Measure the distortion with a distortion meter.

SECTION 4
DIAGRAMS

4-1. SCHEMATIC DIAGRAM

4-1-1. Audio Amp. and Bias OSC Circuit

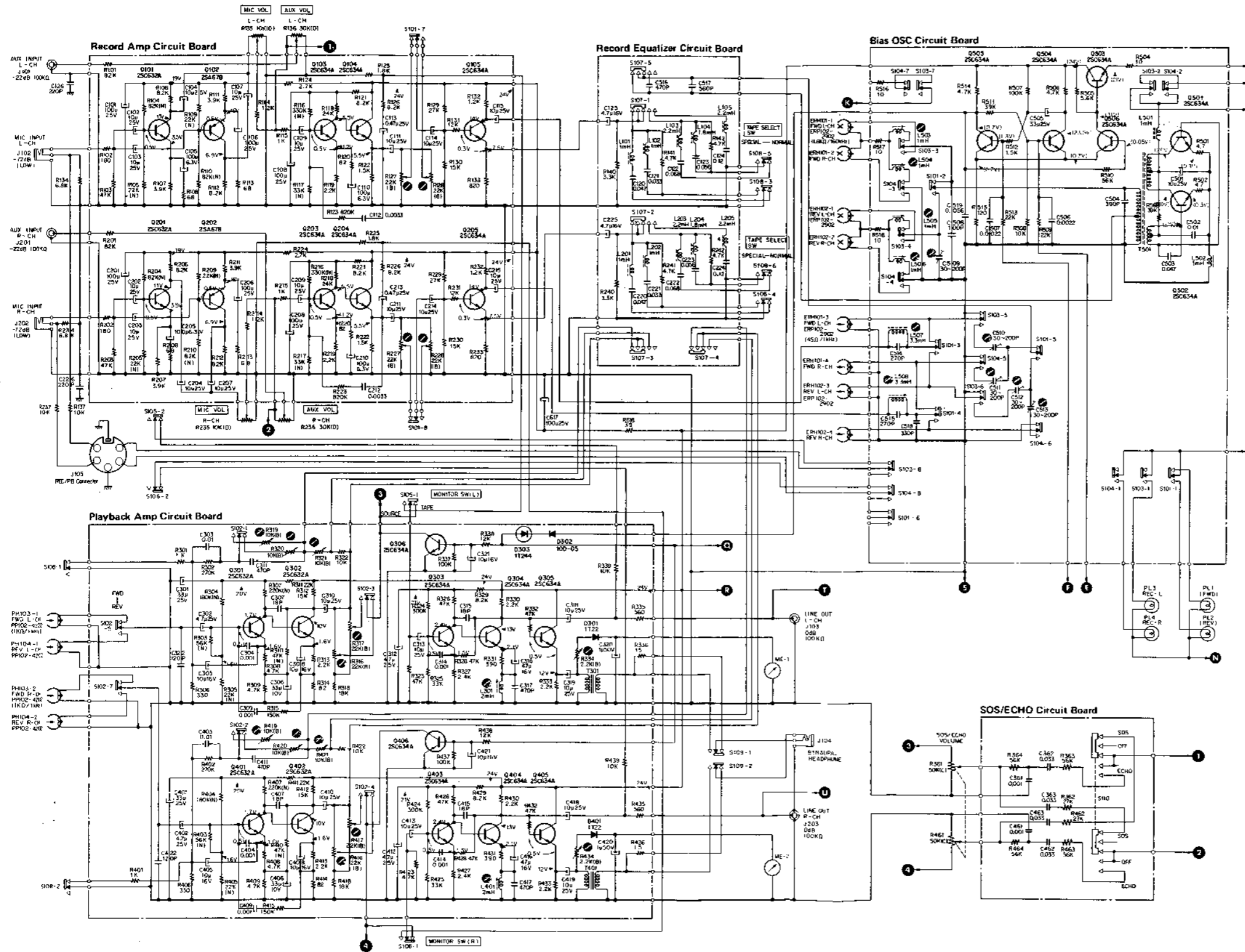

- Note:
- (1) Voltages are measured to ground from indicated point by using a volt-meter (20 kΩ/V DC) with no input signal. Voltages in *italic* are measured in record mode. All voltage readings obtained may vary slightly due to normal component tolerances.
 - (2) All resistors and capacitors are rated in ohms and microfarads unless otherwise indicated.
 - (3) *⊕* - adjustable.
 - (4) Switch positions in this diagram are as per the table below.
- | Ref. No. | Description | Position |
|----------------|----------------------------|---------------------|
| S101 - (1 ~ 8) | DIRECTION (FWD-REV) switch | FWD |
| S107 - (1 ~ 5) | DIRECTION (FWD-REV) switch | FWD |
| S103 - (1 ~ 8) | L-CH REC switch | OFF |
| S104 - (1 ~ 8) | R-CH REC switch | OFF |
| S105 - (1 ~ 2) | L-CH MONITOR switch | TAPE |
| S106 - (1 ~ 2) | R-CH MONITOR switch | TAPE |
| S107 - (1 ~ 5) | Equalizer switch | 19 cm/s (2 1/2 ips) |
| S108 - (1 ~ 6) | TAPE SELECT switch | NORMAL |
| S109 - (1 ~ 2) | HEADPHONE LEVEL switch | I |
| S110 - (1 ~ 2) | SOS/ECHO SELECT switch | OFF |

4-1-2. System Control Circuit

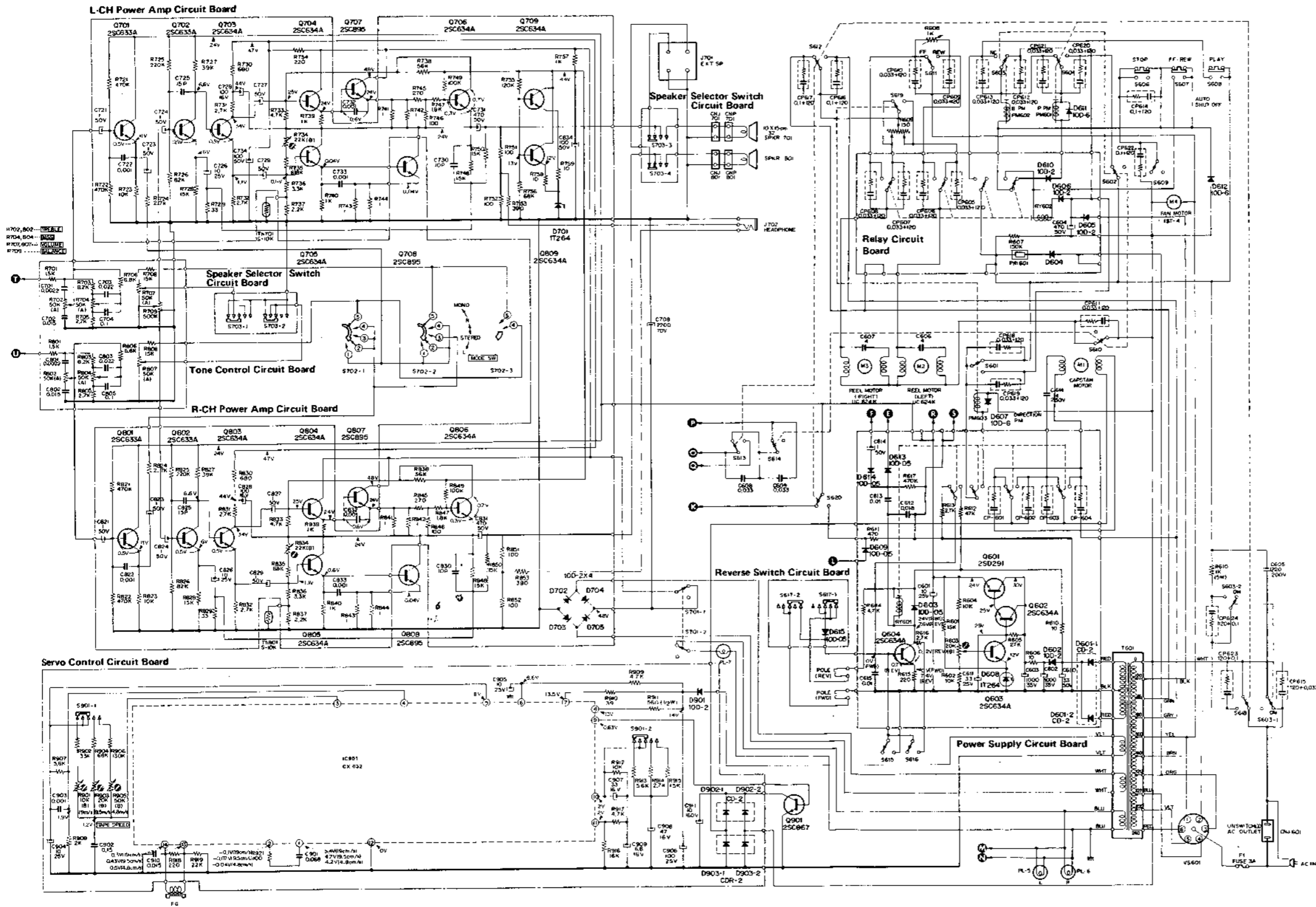

Note:

- Voltages are measured to ground from indicated point by using a voltmeter (20 kΩ/V DC) at the tape speed of 19 cm/s (1 7/8 ips). All voltage readings obtained may vary slightly due to normal component tolerances.
- All resistors and capacitors are rated in ohms and microfarads unless otherwise indicated.
- Adjustable.
- Switch, solenoid and relay positions in this diagram are as per the table below.

Ref. No.	Description	Position
S601, 619	FWD-REV switch	FWD
S602, 605, 610, 614	PLAY, FF-STOP switch	PLAY, FF
S603	POWER switch	ON
S604, 612, 613, 620	PLAY, FF, STOP switch	PLAY
S606	STOP switch	
S607, 611	FF switch	
S608, 615, 616	PLAY switch	
S609	AUTO SHUT-OFF switch	
S617	AUTO REV switch	CONT RE
S618	AUTO OFF switch	PLAY
S701	POWER AMP switch	ON
S702	MODE SELECT switch	STEREO
S703	SPKR SELECT switch	EXT SP
S901	TAPE SPEED switch	19 cm/s (1 7/8 ips)
PM601	PINCH ROLLER solenoid (PLAY, FF, STOP)	PLAY
PM602	BRAKE solenoid (PLAY, FF, STOP)	PLAY, FF
PM603	DIRECTION (FWD-REV) solenoid	FWD
RY601	DIRECTION (FWD-REV) relay	FWD
RY602	FF relay (PLAY, STOP, FF)	PLAY, STOP

4-2. MOUNTING DIAGRAM

4-2-1. Record Amp. Circuit Board

- Conductor Side -

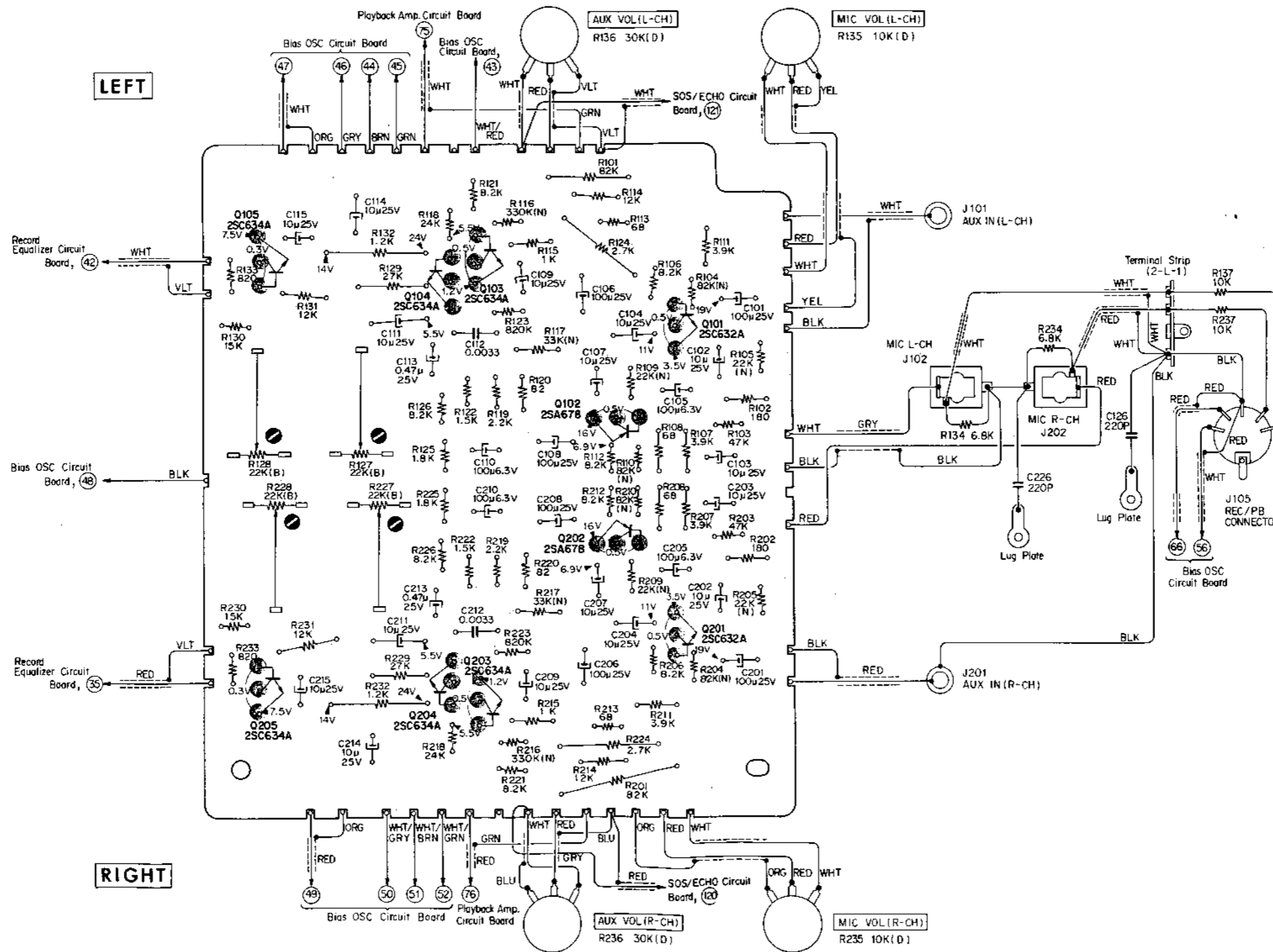

Printed Circuit Board
Part No. 1-581-040-11

- Component Side -

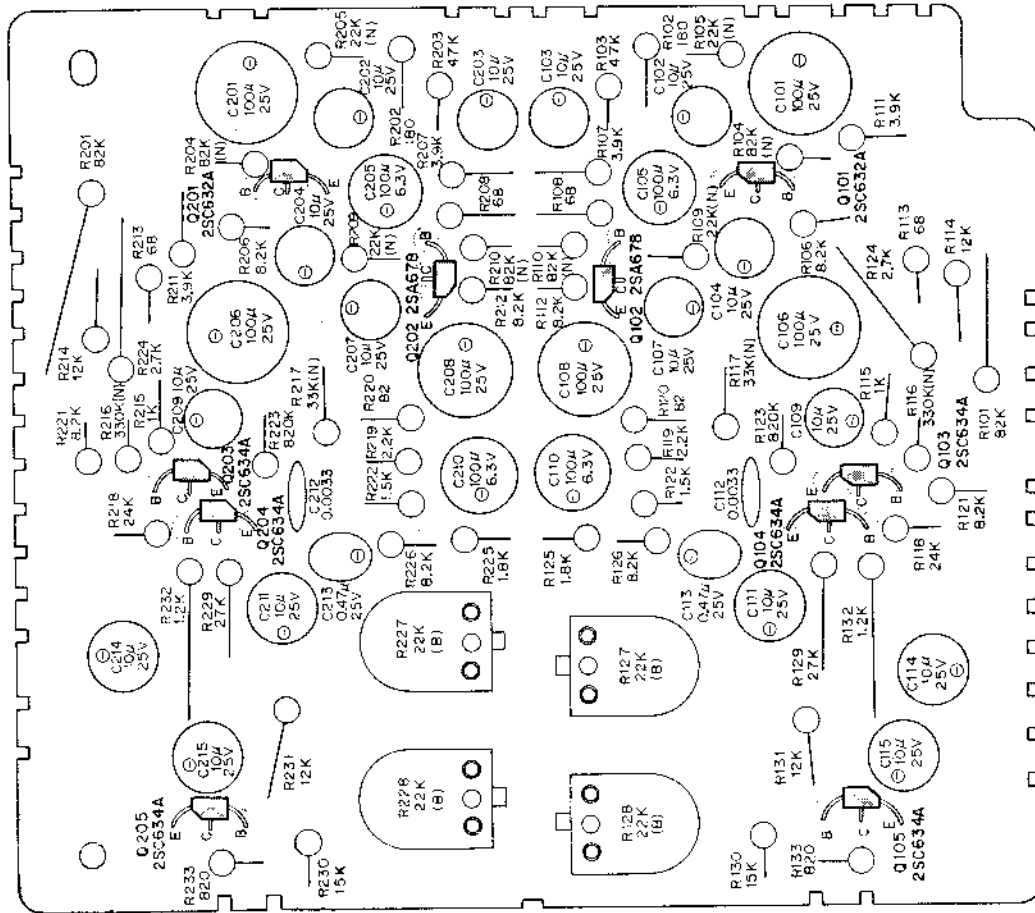

2SC634A, 2SC634A

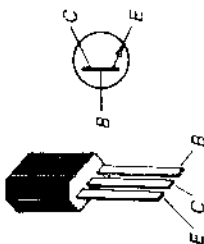

2SA678

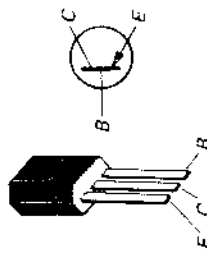

4-2-2. Record Equalizer Circuit Board
 - Conductor Side -

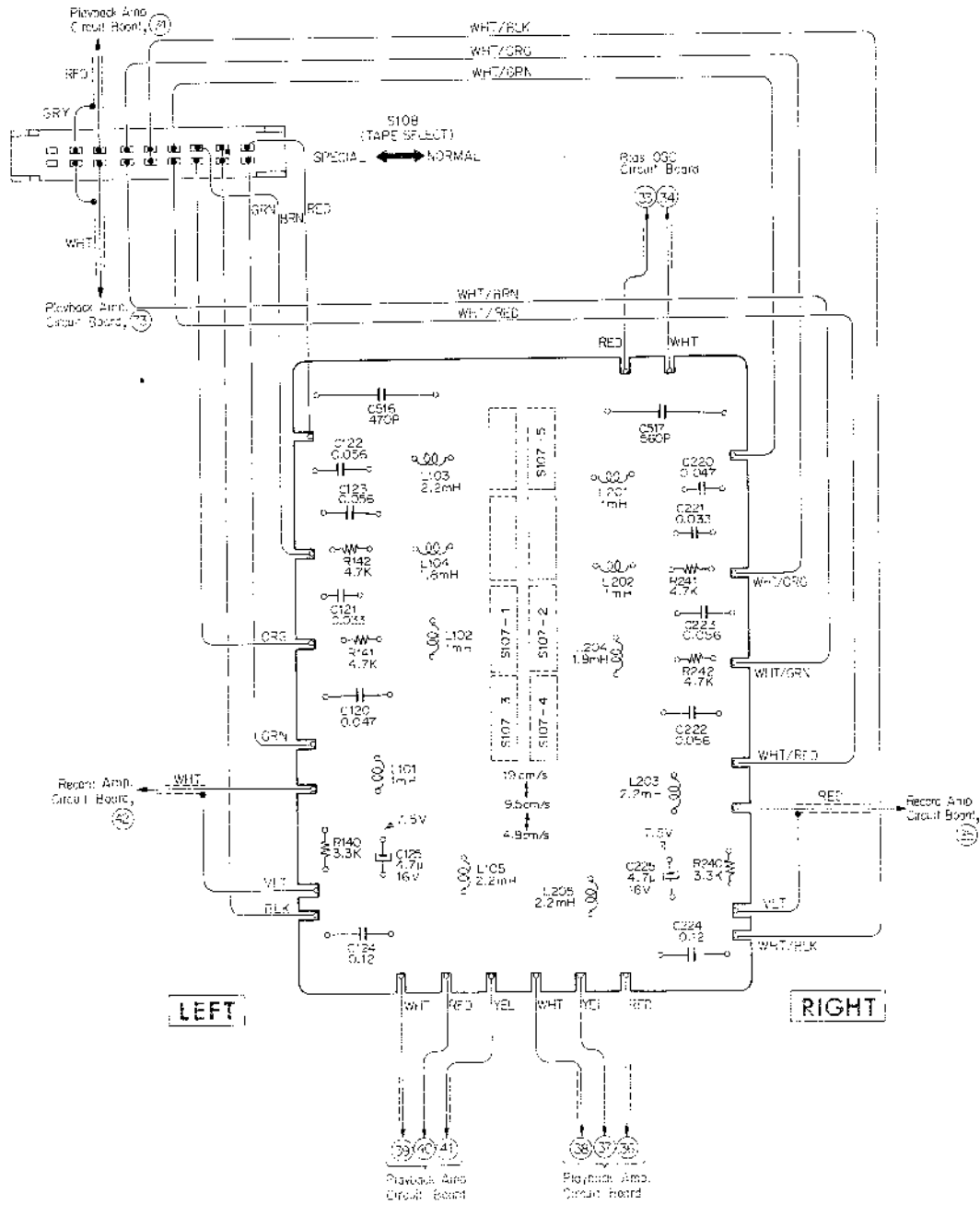

Printed Circuit Board
 Part No. 1 581-041-11

— Component Side —

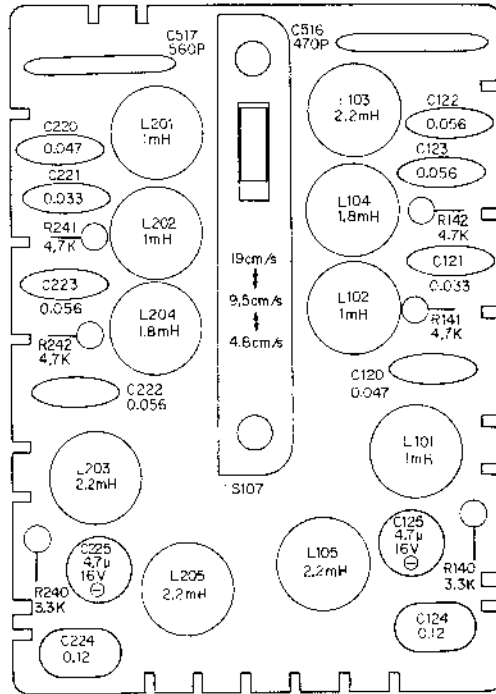

4-2-3. Playback Amp. Circuit Board
 - Component Side -

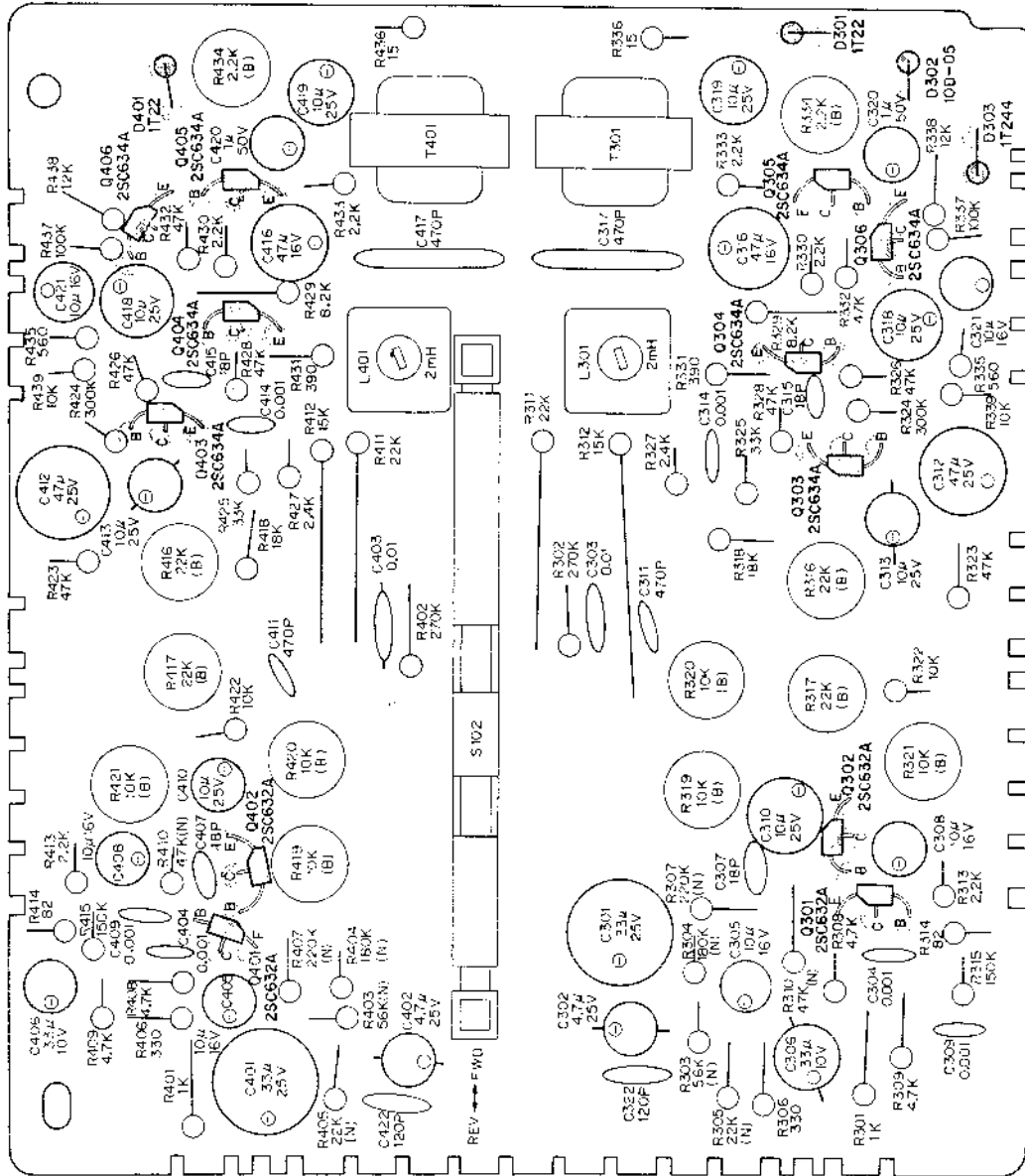

2SC632A, 2SC634A

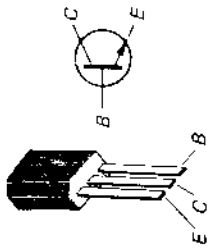

1T244

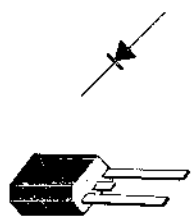

1T22, 10D-05

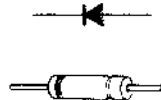

- Conductor Side -

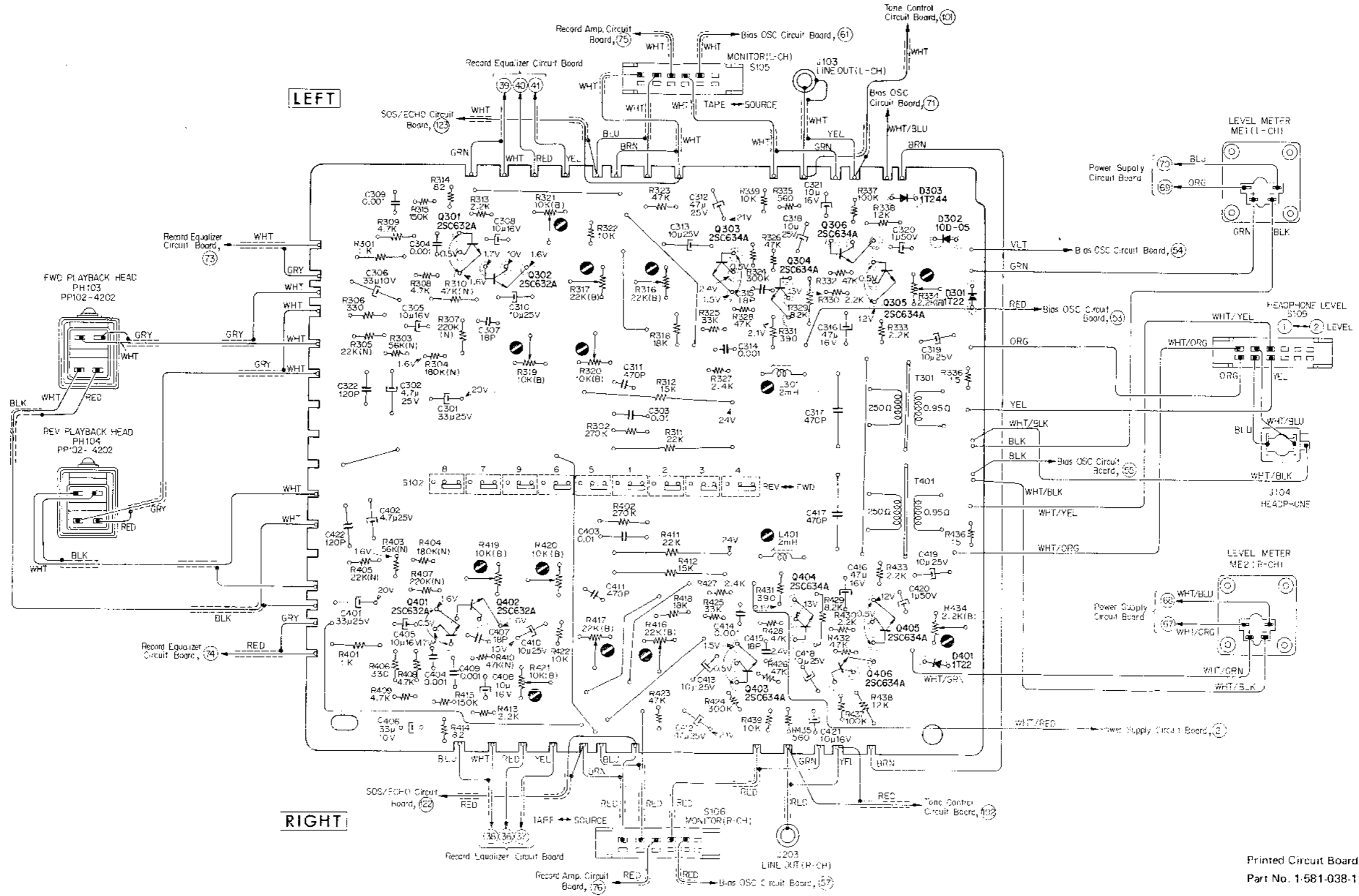

Printed Circuit Board
Part No. 1-581-038-11

FRP102-2902

4-2-4. Bias OSC Circuit Board
 - Conductor Side -

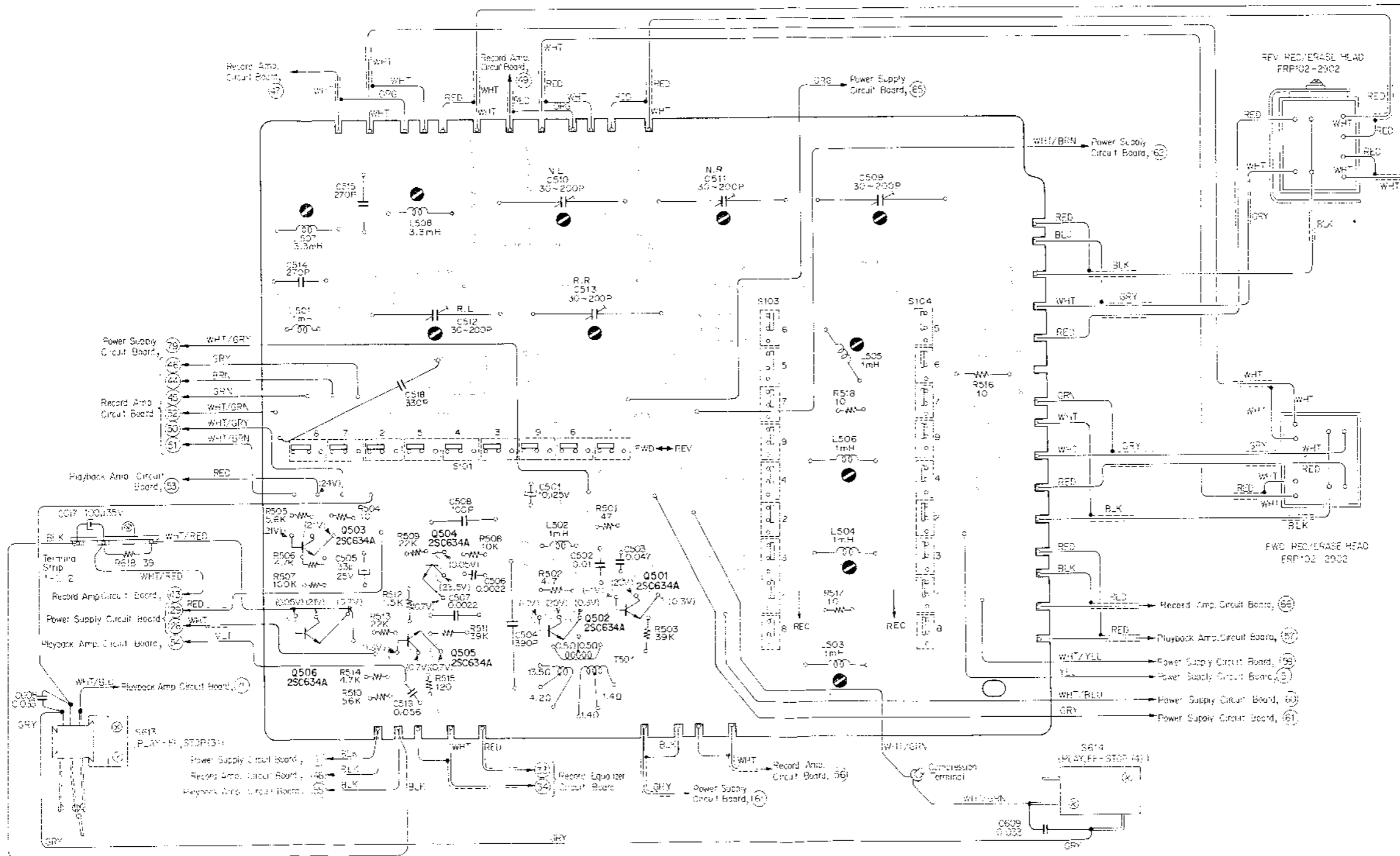

Printed Circuit Board
 Part No. 1-581-039-11

- Component Side -

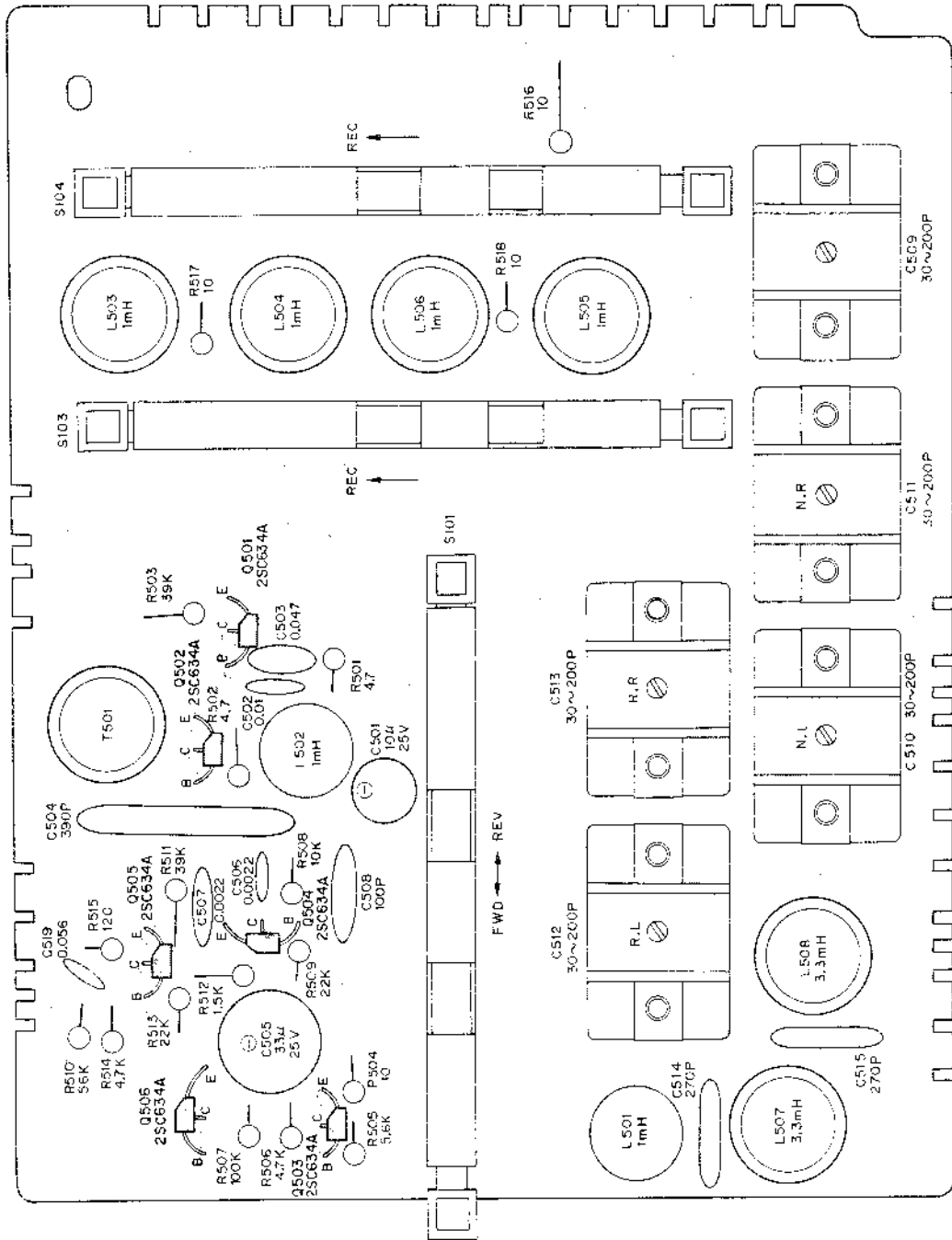

2SC6344

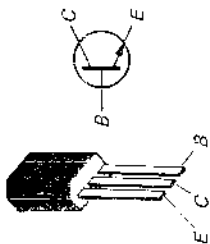

4-2.5. SOS/ECHO Circuit Board
 — Conductor Side —

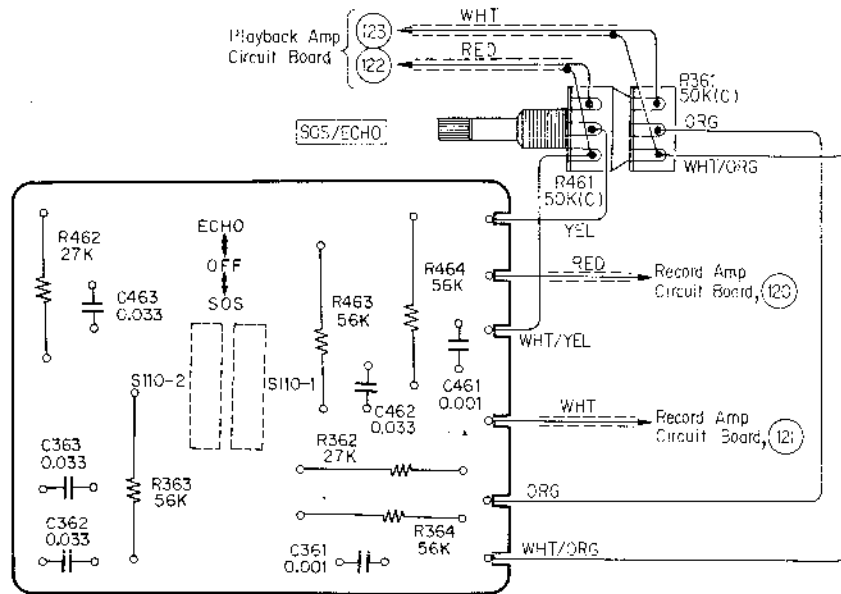

Printed Circuit Board
 Part No. 1-581-111-11

— Component Side —

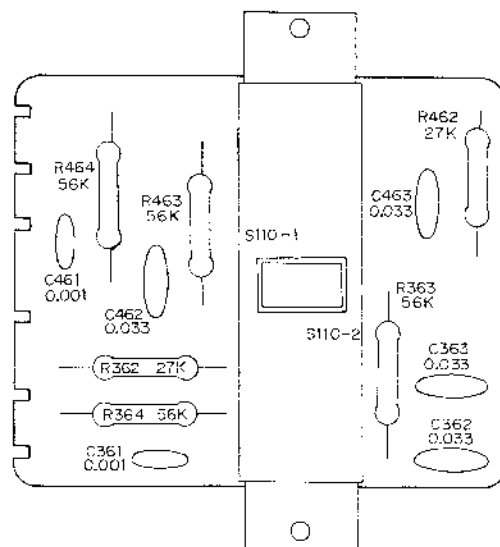

4-2-6. **Speaker Selector Switch Circuit Board**
 – Conductor Side –

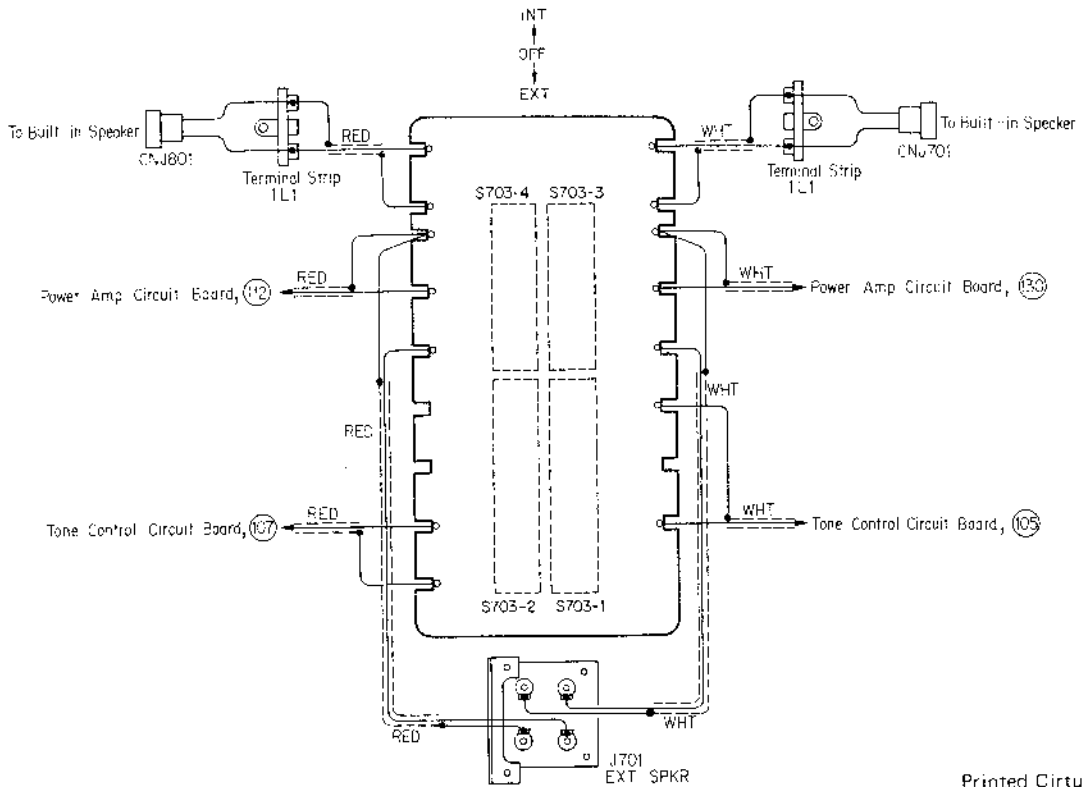

Printed Circuit Board
 Part No. 1-581-112-11

– Component Side –

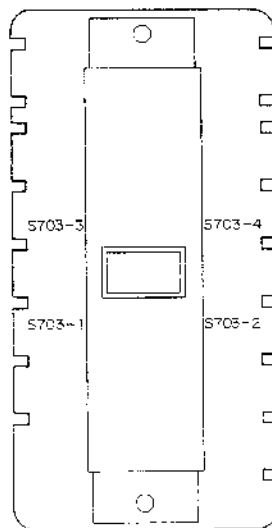

4-2-7. Control Circuit Board
 — Conductor Side —

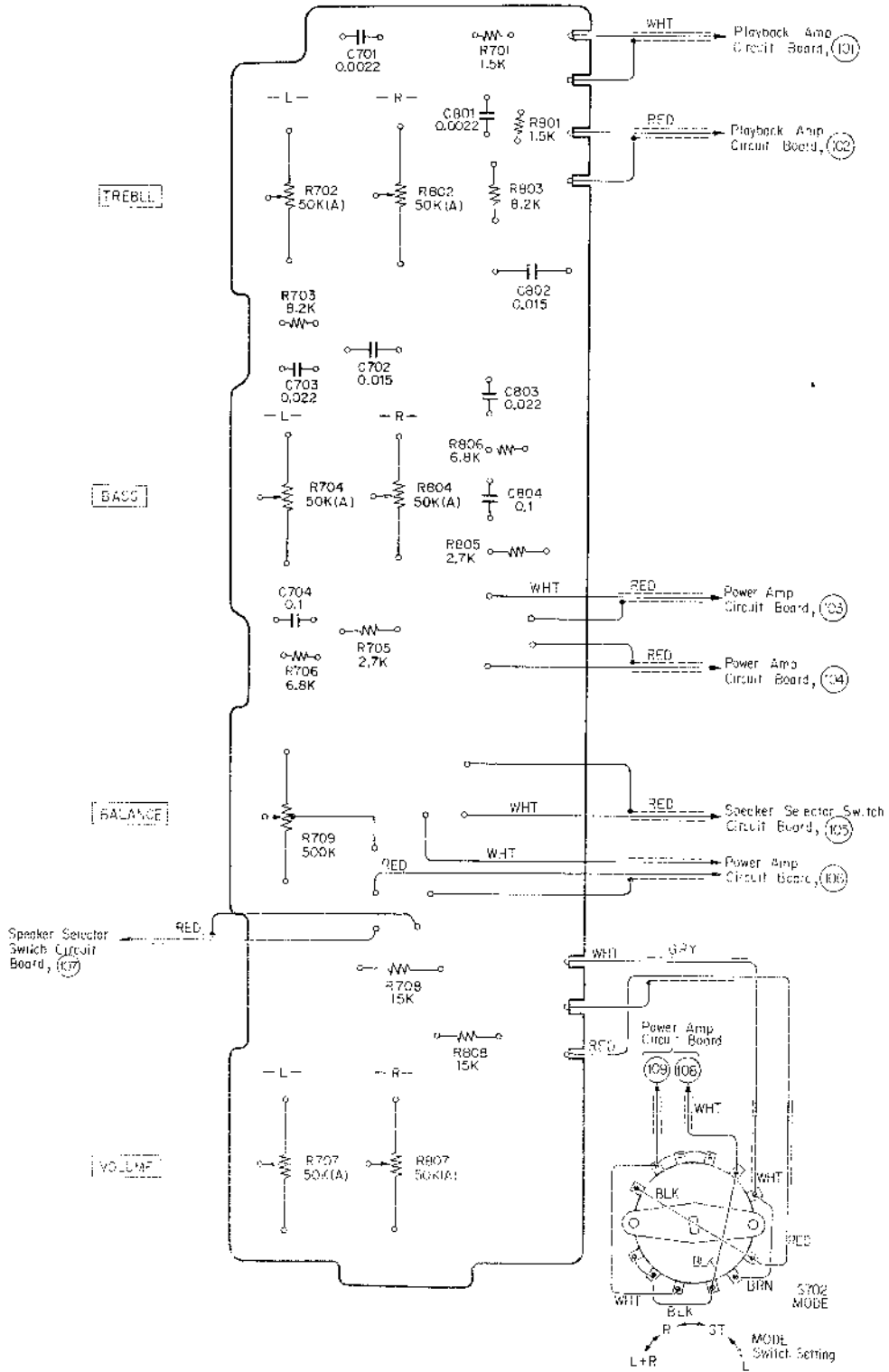

Printed Circuit Board
 Part No. 1-581-110-11

-- Component Side --

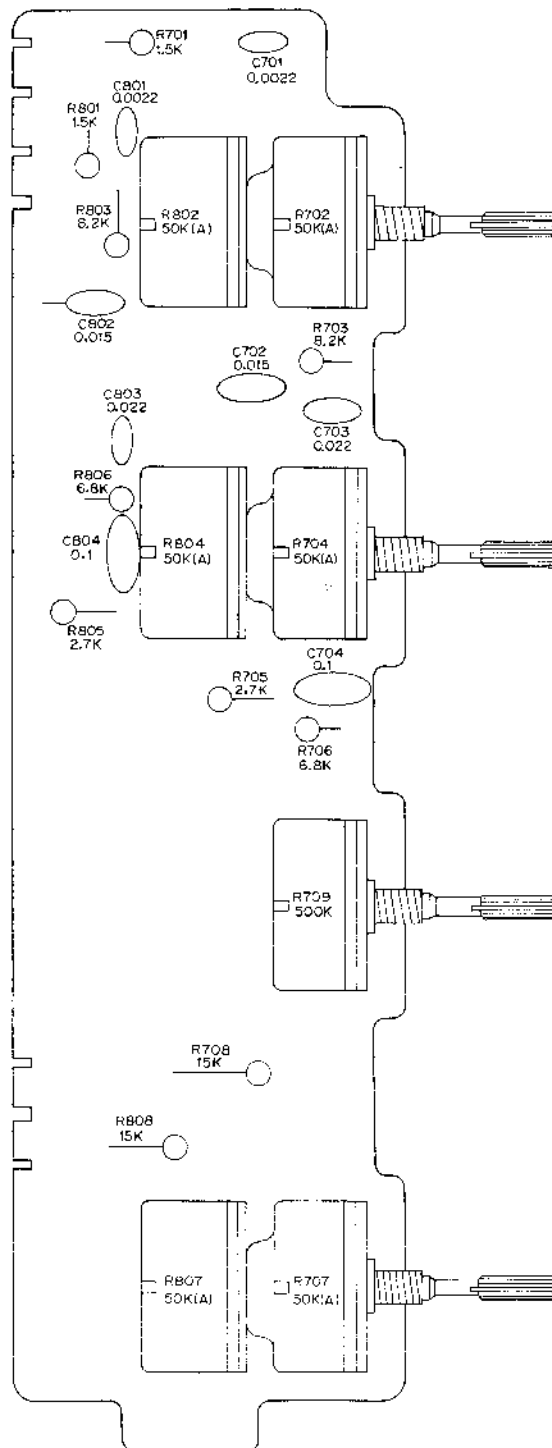

4-2-8. Power Amp. Circuit Board
 - Conductor Side -

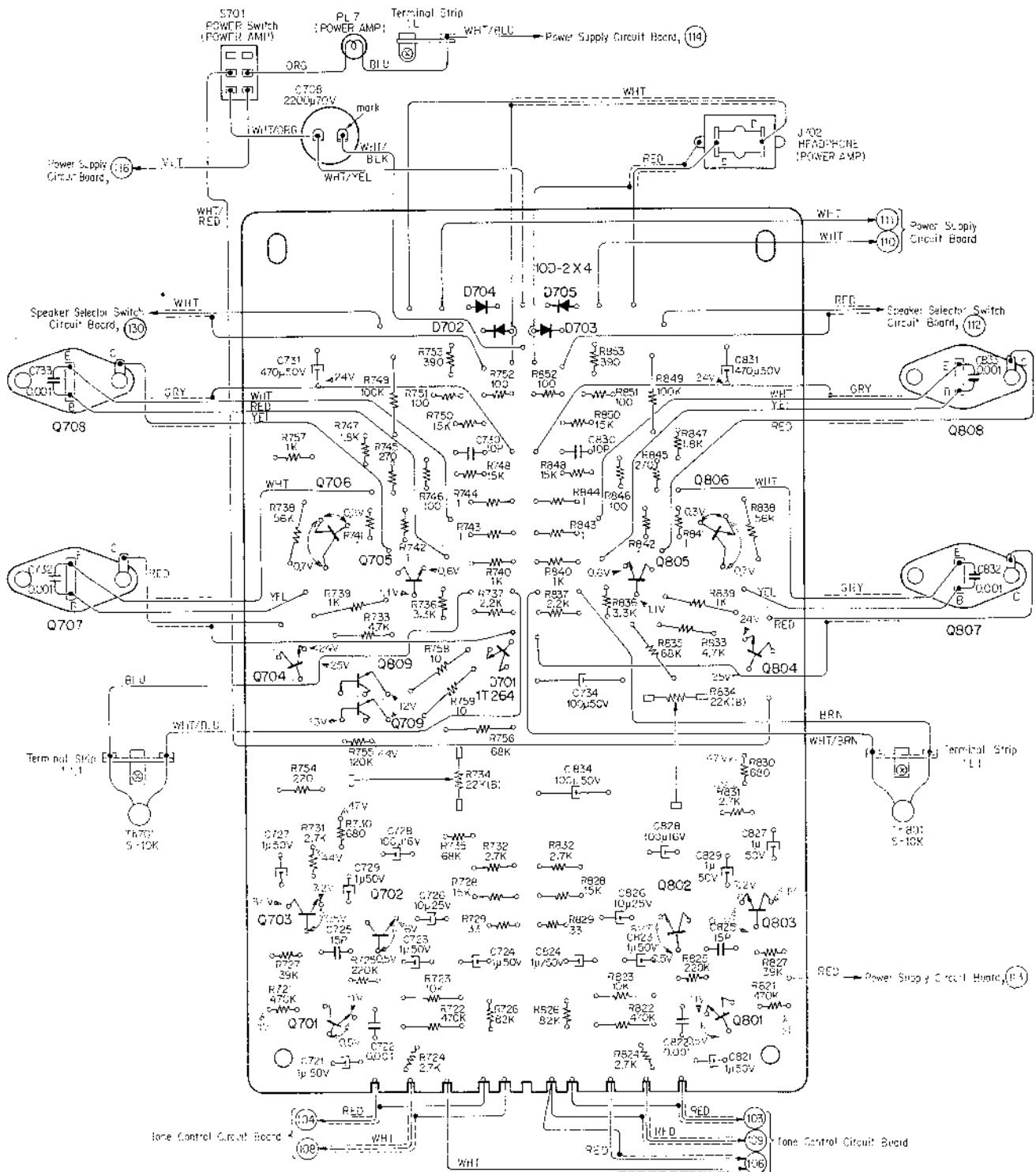

Printed Circuit Board
 Part No. 1-581-109-11

100-200

- Component Side -

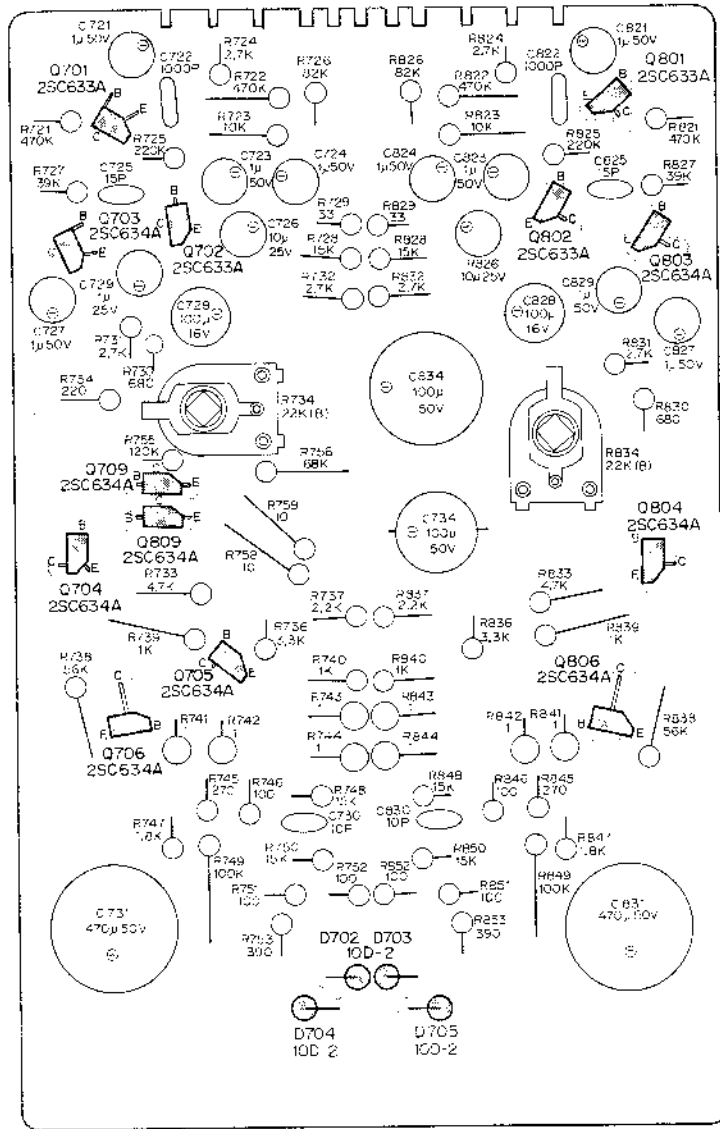

2SC895

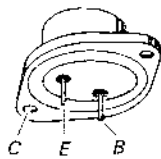

2SC633A, 2SC634A

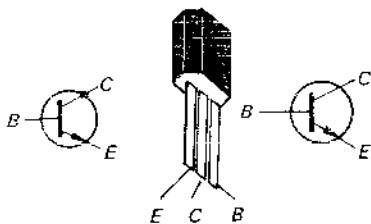

1T264-41

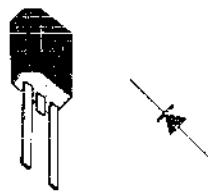

10D-2

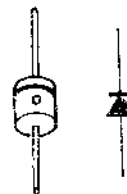

4-2-9. Relay Circuit Board
 - Component Side -

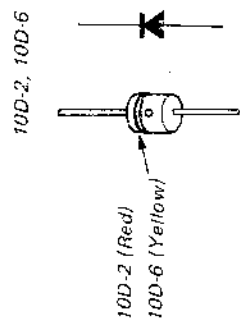
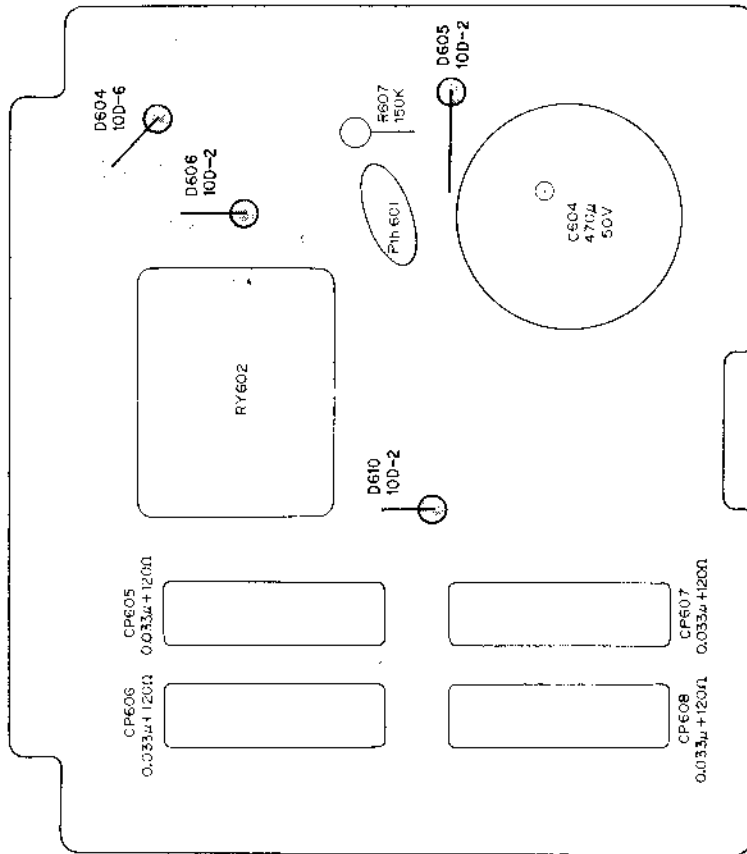

- Conductor Side -

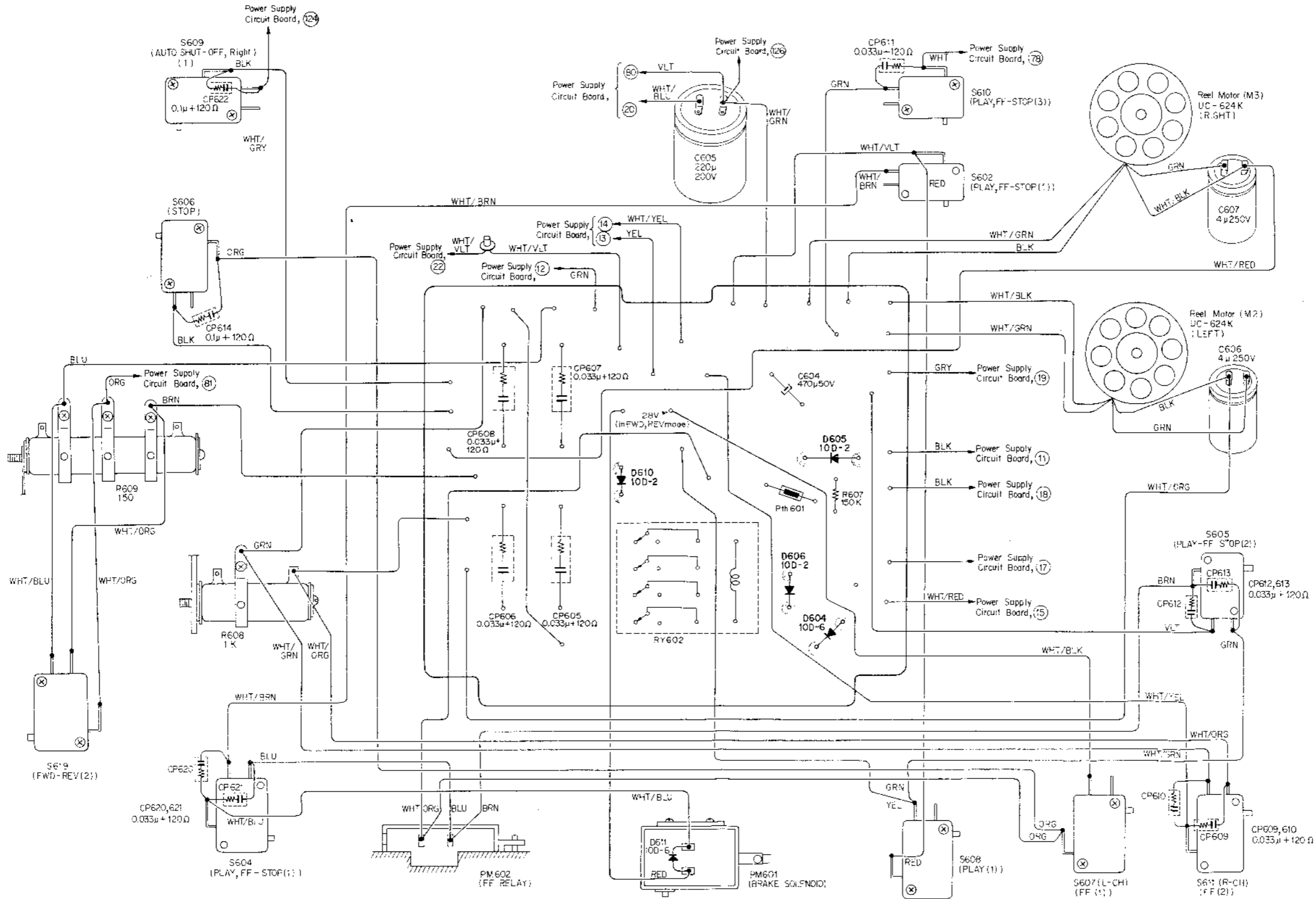

Printed Circuit Board
Part No. 1-581-044-12

7-30-68 10-7-70

4-2-10. Power Supply Circuit Board
 - Conductor Side -

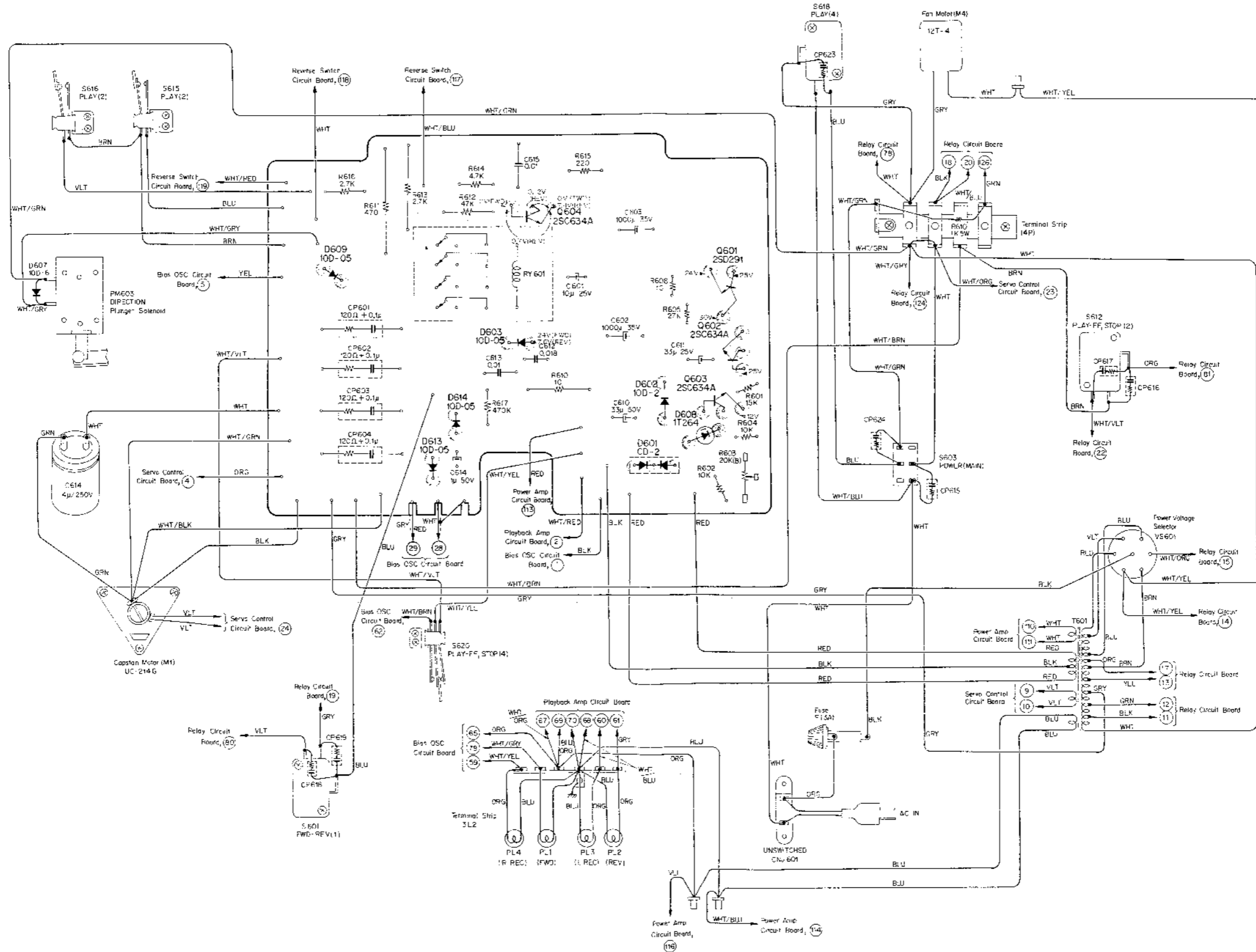

Printed Circuit Board
 Part No. 1-581-043-12

- Component Side -

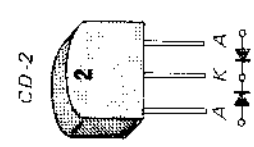
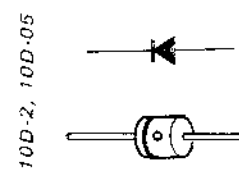
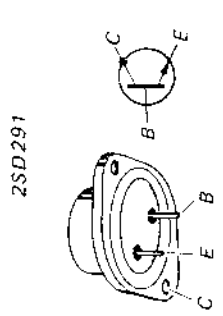
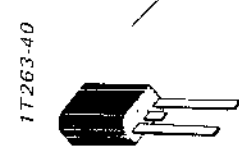
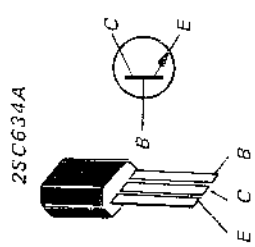
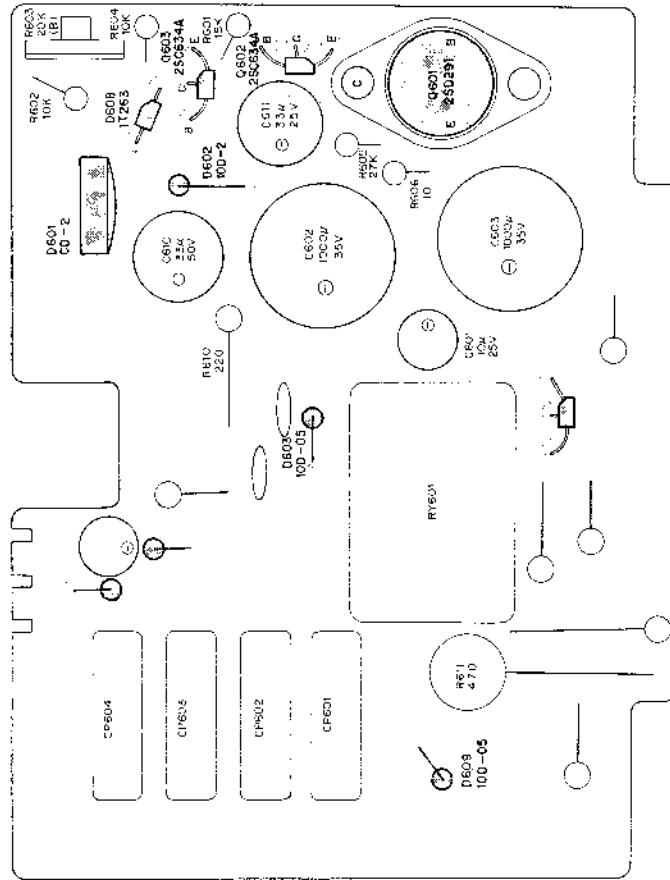

4-2-11. Servo Control Circuit Board

— Conductor Side —

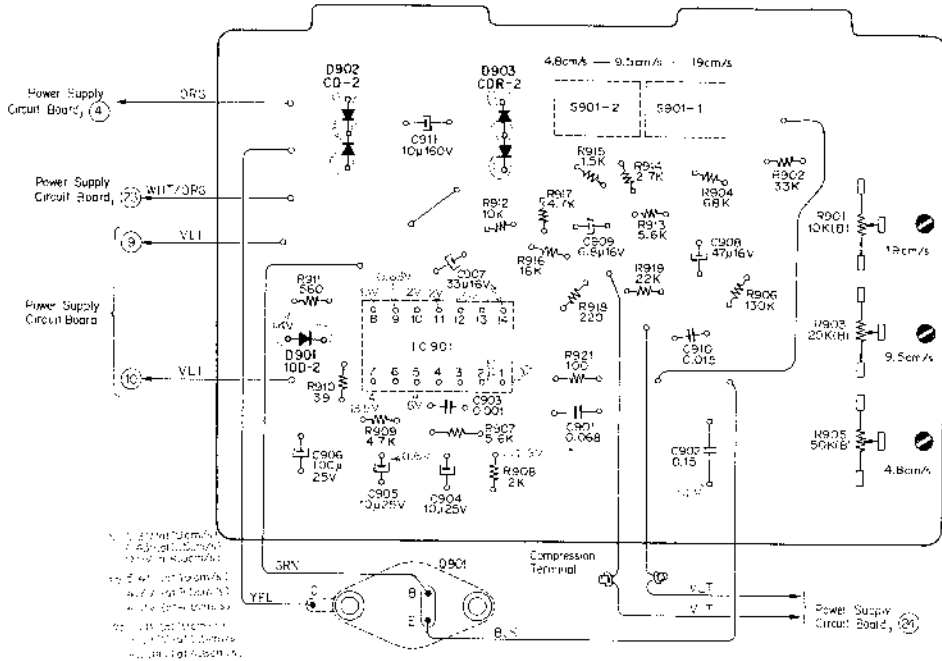

Printed Circuit Board
 Part No. 1-581-005-12

— Component Side —

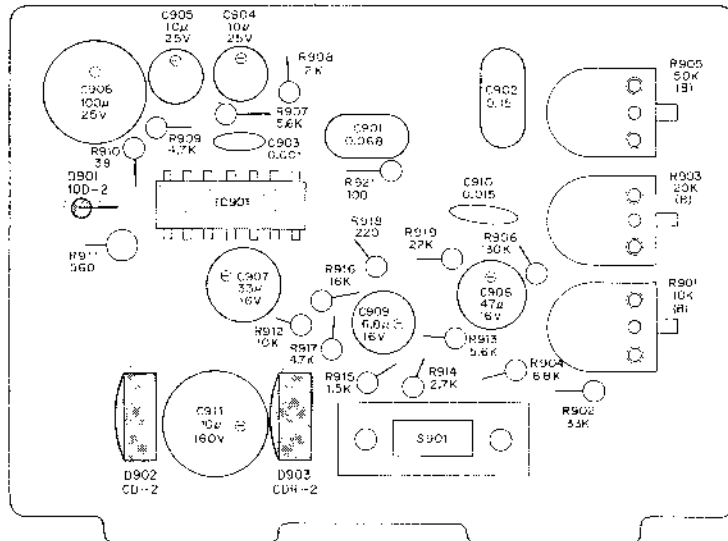

2SC867

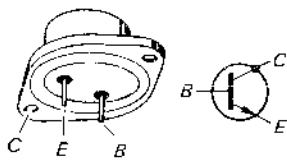

CD-2

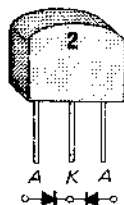

CDR-2

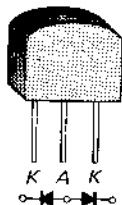

10D-2

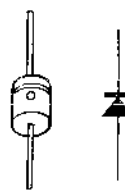

CX-032

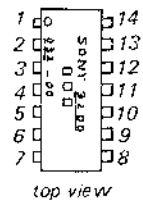

4-2-12. Reverse Switch Circuit Board

— Conductor Side —

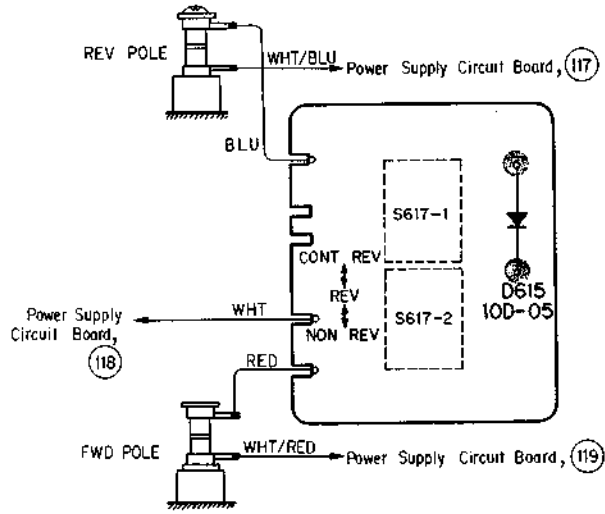

Printed Circuit Board
Part No. 1-581-045-11

— Component Side —

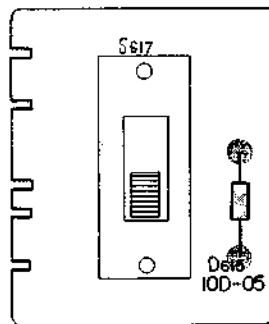

4.3. LEVEL DIAGRAM Playback

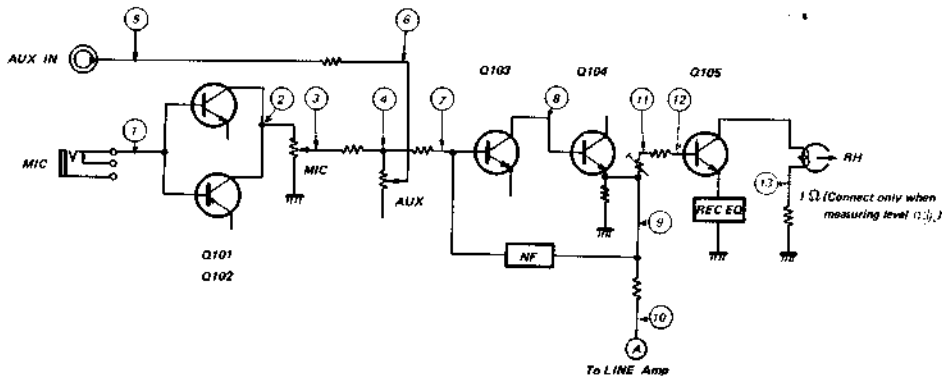
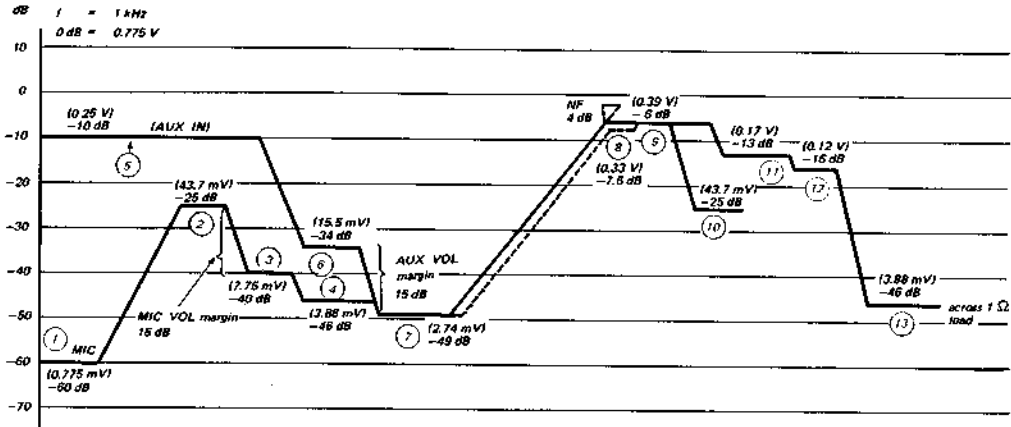

Record

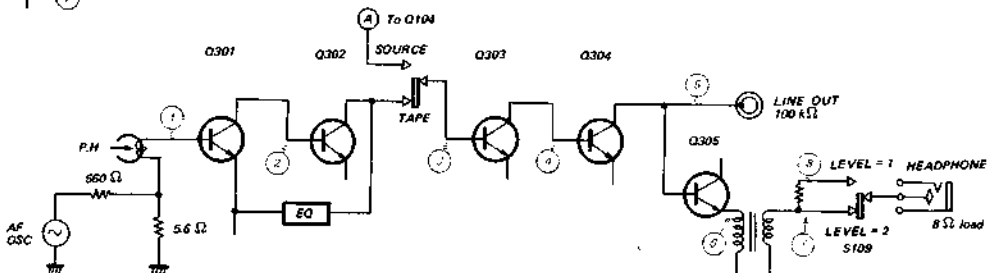
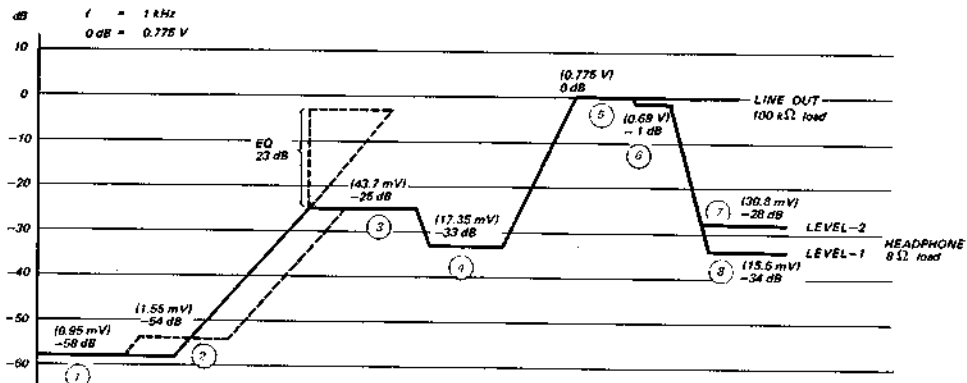

Power Amp.

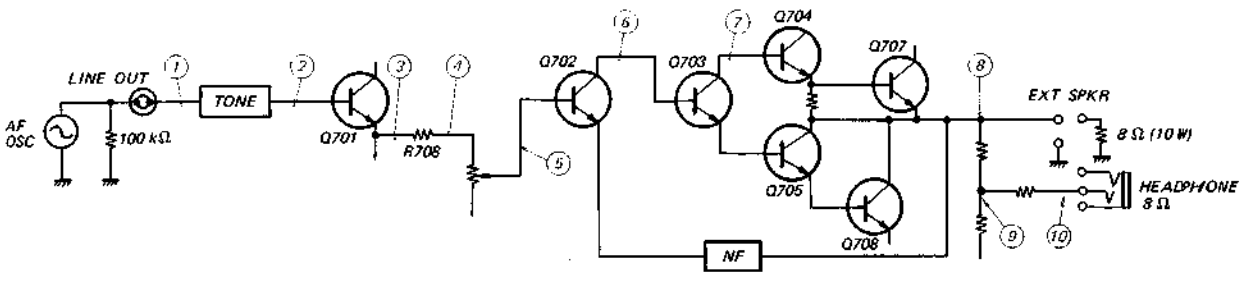
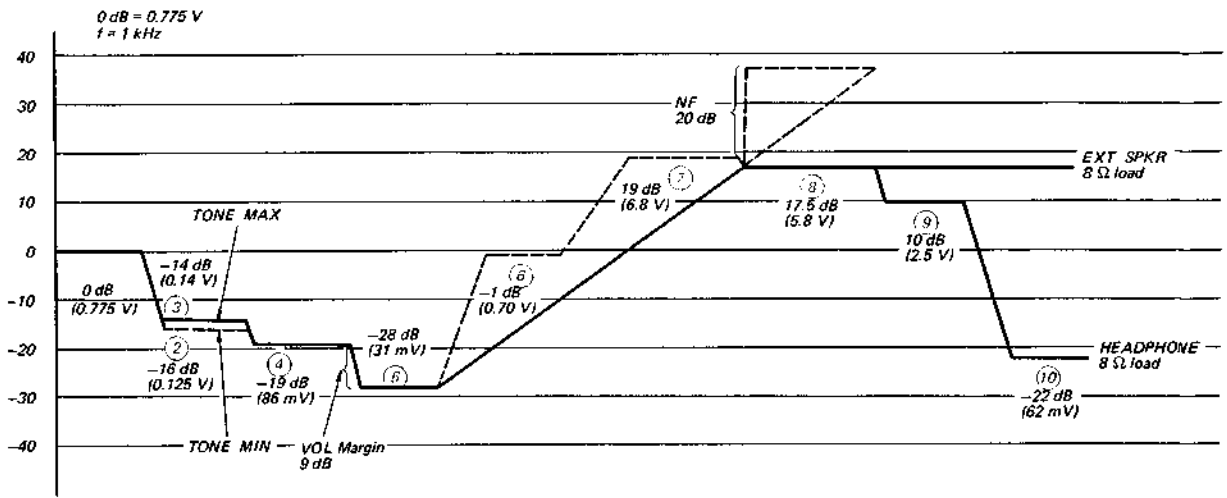

SECTION 5

ELECTRICAL PARTS LIST

<u>Ref. No.</u>	<u>Part No.</u>	<u>Description</u>	<u>Ref. No.</u>	<u>Part No.</u>	<u>Description</u>
MOUNTED CIRCUIT BOARDS			C112, 212	1-105-667-12	0.0033 μ F 50 V mylar
	X-34970-61-1	record amp	C113, 213	1-127-093	0.47 μ F 25 V electrolytic, alox
	X-34970-62-1	record equalizer	C114, 214	1-121-398	10 μ F 25 V electrolytic
	X-34970-63-1	playback amp	C115, 215	1-121-398	10 μ F 25 V electrolytic
	X-34970-64-1	bias osc	RESISTORS		
	X-34970-66-1	relay	All resistors are $\frac{1}{4}$ W and carbon type, unless otherwise indicated.		
	X-34970-68-1	servo control	R101, 201	1-242-719	82 k Ω
	X-34980-51-1	tone control	R102, 202	1-242-655	180 Ω
	X-34980-52-1	power amp	R103, 203	1-242-713	47 k Ω
	X-34980-53-1	power supply	R104, 204	1-242-719-09	82 k Ω , low noise
	X-34980-54-1	SOS/ECHO	R105, 205	1-242-705-09	22 k Ω , low noise
	X-34980-55-1	reverse switch	R106, 206	1-242-695	8.2 k Ω
	X-34980-56-1	speaker selector switch	R107, 207	1-242-687	3.9 k Ω
PRINTED CIRCUIT BOARDS			R108, 208	1-242-645	68 Ω
	1-581-005-12	servo control	R109, 209	1-242-705-09	22 k Ω , low noise
	1-581-038-11	playback amp	R110, 210	1-242-719-09	82 k Ω , low noise
	1-581-039-11	bias osc	R111, 211	1-242-687	3.9 k Ω
	1-581-040-11	record amp	R112, 212	1-242-695	8.2 k Ω
	1-581-041-11	record equalizer	R113, 213	1-242-645	68 Ω
	1-581-043-12	power supply	R114, 214	1-242-699	12 k Ω
	1-581-044-12	relay	R115, 215	1-242-673	1 k Ω
	1-581-045-11	reverse switch	R116, 216	1-242-733-09	330 k Ω , low noise
	1-581-109-11	power amp	R117, 217	1-242-709-09	33 k Ω , low noise
	1-581-110-11	tone control	R118, 218	1-242-706	24 k Ω
	1-581-111-11	SOS/ECHO	R119, 219	1-242-681	2.2 k Ω
	1-581-112-11	speaker selector switch	R120, 220	1-242-647	82 Ω
REC AMP CIRCUIT			R121, 221	1-242-695	8.2 k Ω
SEMICONDUCTORS			R122, 222	1-242-677	1.5 k Ω
Q101, 201		transistor, 2SC632A	R123, 223	1-242-743	820 k Ω
Q102, 202		transistor, 2SA678	R124, 224	1-242-683	2.7 k Ω
Q103, 203		transistor, 2SC634A	R125, 225	1-242-679	1.8 k Ω
Q104, 204		transistor, 2SC634A	R126, 226	1-242-695	8.2 k Ω
Q105, 205		transistor, 2SC634A	R127, 227	1-222-775	22 k Ω (B), semi-fixed
CAPACITORS			R128, 228	1-222-775	22 k Ω (B), semi-fixed
C101, 201	1-121-416	100 μ F 25 V electrolytic	R129, 229	1-242-707	27 k Ω
C102, 202	1-121-398	10 μ F 25 V electrolytic	R130, 230	1-242-701	15 k Ω
C103, 203	1-121-398	10 μ F 25 V electrolytic	R131, 231	1-242-699	12 k Ω
C104, 204	1-121-398	10 μ F 25 V electrolytic	R132, 232	1-242-675	1.2 k Ω
C105, 205	1-121-413	100 μ F 6.3 V electrolytic	R133, 233	1-242-671	820 Ω
C106, 206	1-121-416	100 μ F 25 V electrolytic	R134, 234	1-244-693	6.8 k Ω
C107, 207	1-121-398	10 μ F 25 V electrolytic	REC EQUALIZER CIRCUIT		
C108, 208	1-121-416	100 μ F 25 V electrolytic	MICROINDUCTORS		
C109, 209	1-121-398	10 μ F 25 V electrolytic	L101, 201	1-407-492	1 mH
C110, 210	1-121-413	100 μ F 6.3 V electrolytic	L102, 202	1-407-492	1 mH
C111, 211	1-121-398	10 μ F 25 V electrolytic	L103, 203	1-407-496	2.2 mH
			L104, 204	1-407-495	1.8 mH
			L105, 205	1-407-496	2.2 mH

<u>Ref. No.</u>	<u>Part No.</u>	<u>Description</u>		
<u>CAPACITORS</u>				
C120, 220	1-106-041-12	0.047 μ F	50 V	mylar
C121, 221	1-106-037-12	0.033 μ F	50 V	mylar
C122, 222	1-105-682-12	0.056 μ F	50 V	mylar
C123, 223	1-105-682-12	0.056 μ F	50 V	mylar
C124, 224	1-105-686-12	0.12 μ F	50 V	mylar
C125, 225	1-121-395	4.7 μ F	25 V	electrolytic
C516	1-107-185	470 pF	500 V	silvered mica
C517	1-107-187	560 pF	500 V	silvered mica

RESISTORS

R140, 240	1-242-685	3.3 k Ω	$\frac{1}{4}$ W	carbon
R141, 241	1-242-689	4.7 k Ω	$\frac{1}{4}$ W	carbon
R142, 242	1-242-689	4.7 k Ω	$\frac{1}{4}$ W	carbon

SWITCH

S107	1-514-634	slide; EQUALIZER
------	-----------	------------------

AMP CHASSIS CIRCUIT

CAPACITOR

C126, 226	1-107-139	220 pF	50 V	silvered mica
-----------	-----------	--------	------	---------------

RESISTORS

R135, 235	1-222-498	10 k Ω (D)		variable, MIC
R136, 236	1-222-497	30 k Ω (D)		variable, AUX
R137, 237	1-244-697	10 k Ω	$\frac{1}{4}$ W	carbon

JACKS

J101, 201	1-507-142	phono; AUX IN
J102, 202	1-507-281	MIC
J103, 203	1-507-142	phono; LINE OUT
J104	1-507-282	binaural; HEADPHONE
J105	1-509-359	connector; REC/PB

SWITCHES

S105	1-514-836	lever; MONITOR
S106	1-514-836	lever; MONITOR
S107		- described in REC EQUALIZER CIRCUIT -
S108	1-514-867	lever; TAPE SELECT
S109	1-514-768	lever; HEADPHONE LEVEL

MISCELLANEOUS

PL3,4	1-518-093-21	lamp, 2 V
-------	--------------	-----------

<u>Ref. No.</u>	<u>Part No.</u>	<u>Description</u>
ME1, 2	1-524-082-11	meter, VU
J701	1-536-309	4 p terminal, push: speaker

HEAD DECK CIRCUIT

ERH101,102	8-828-629-20	head, record/erase (ERP102-2902)
PH103, 104	8-829-142-20	head, playback (PP102-4202)
PL1, 2	1-518-093-21	lamp, 2 V

PB AMP CIRCUIT

SEMICONDUCTORS

Q301, 401		transistor,	2SC632A
Q302, 402		transistor,	2SC632A
Q303, 403		transistor,	2SC634A
Q304, 404		transistor,	2SC634A
Q305, 405		transistor,	2SC634A
Q306, 406		transistor,	2SC634A
D301, 401		diode,	1T-22
D302		diode,	10D-05
D303		diode,	1T244

COIL & TRANSFORMER

L301, 401	1-409-130	trap, 2 mH
T301, 401	1-427-209	output

CAPACITORS

C301, 401	1-121-404	33 μ F	25 V	electrolytic
C302, 402	1-121-395	4.7 μ F	25 V	electrolytic
C303, 403	1-105-833-12	0.01 μ F	50 V	mylar
C304, 404	1-105-821-12	0.001 μ F	50 V	mylar
C305, 405	1-121-471	10 μ F	16 V	electrolytic
C306, 406	1-121-402	33 μ F	10 V	electrolytic
C307, 407	1-107-113	18 pF	50 V	silvered mica
C308, 408	1-121-471	10 μ F	16 V	electrolytic
C309, 409	1-105-821-12	0.001 μ F	50 V	mylar
C310, 410	1-121-398	10 μ F	25 V	electrolytic
C311, 411	1-102-098	470 pF	50 V	ceramic
C312, 412	1-121-410	47 μ F	25 V	electrolytic
C313, 413	1-121-398	10 μ F	25 V	electrolytic
C314, 414	1-105-821-12	0.001 μ F	50 V	mylar
C315, 415	1-107-113	18 pF	50 V	silvered mica
C316, 416	1-121-409	47 μ F	16 V	electrolytic
C317, 417	1-107-244	470 pF	50 V	silvered mica
C318, 418	1-121-398	10 μ F	25 V	electrolytic
C319, 419	1-121-398	10 μ F	25 V	electrolytic
C320, 420	1-121-391	1 μ F	50 V	electrolytic
C321, 421	1-121-471	10 μ F	16 V	electrolytic
C322, 422	1-107-133	120 pF	50 V	silvered mica

Ref. No. Part No. Description

RESISTORS

All resistors are 1/4W and carbon type, unless otherwise indicated.

R301, 401	1-242-673	1 kΩ	
R302, 402	1-242-731	270 kΩ	
R303, 403	1-242-715-09	56 kΩ	low noise
R304, 404	1-242-727-09	180 kΩ	low noise
R305, 405	1-242-705-09	22 kΩ	low noise
R306, 406	1-242-661	330 Ω	
R307, 407	1-242-729-09	220 kΩ	low noise
R308, 408	1-242-689	4.7 kΩ	
R309, 409	1-242-689	4.7 kΩ	
R310, 410	1-242-713-09	47 kΩ	low noise
R311, 411	1-242-705	22 kΩ	
R312, 412	1-242-701	15 kΩ	
R313, 413	1-242-681	2.2 kΩ	
R314, 414	1-242-647	82 Ω	
R315, 415	1-242-725	150 kΩ	
R316, 416	1-221-979	22 kΩ (B),	semi-fixed
R317, 417	1-221-979	22 kΩ (B),	semi-fixed
R318, 418	1-242-703	18 kΩ	
R319, 419	1-222-701	10 kΩ (B),	semi-fixed
R320, 420	1-222-701	10 kΩ (B),	semi-fixed
R321, 421	1-222-701	10 kΩ (B),	semi-fixed
R322, 422	1-242-697	10 kΩ	
R323, 423	1-242-713	47 kΩ	
R324, 424	1-242-732	300 kΩ	
R325, 425	1-242-709	33 kΩ	
R326, 426	1-242-713	47 kΩ	
R327, 427	1-242-682	2.4 kΩ	
R328, 428	1-242-713	47 kΩ	
R329, 429	1-242-695	8.2 kΩ	
R330, 430	1-242-681	2.2 kΩ	
R331, 431	1-242-663	390 Ω	
R332, 432	1-242-713	47 kΩ	
R333, 433	1-242-681	2.2 kΩ	
R334, 434	1-221-997	2.2 kΩ (B),	semi-fixed
R335, 435	1-242-667	560 Ω	
R336, 436	1-242-629	15 Ω	
R337, 437	1-242-721	100 kΩ	
R338, 438	1-242-699	12 kΩ	
R339, 439	1-242-697	10 kΩ	

SWITCH

S102	1-514-813	slide; DIRECTION
------	-----------	------------------

Ref. No. Part No. Description

SOS/ECHO CIRCUIT

CAPACITORS

C361, 461	1-105-661-12	0.001 μF	50 V	mylar
C362, 462	1-105-679-12	0.033 μF	50 V	mylar
C363, 463	1-105-679-12	0.033 μF	50 V	mylar

RESISTORS

R361, 461	1-221-910	50 kΩ (C)/50 kΩ (C)		variable (SOS/ECHO)
R362, 462	1-244-707	27 kΩ	1/4W	carbon
R363, 463	1-244-715	56 kΩ	1/4W	carbon
R364, 464	1-244-715	56 kΩ	1/4W	carbon

BIAS OSC CIRCUIT

SEMICONDUCTORS

Q501~506		transistor,	2SC634A
----------	--	-------------	---------

COILS & TRANSFORMER

L501	1-407-195	micro inductor, 1 mH
L502	1-407-195	micro inductor, 1 mH
L503	1-407-284	variable inductor, 1 mH
L504	1-407-284	variable inductor, 1 mH
L505	1-407-284	variable inductor, 1 mH
L506	1-407-284	variable inductor, 1 mH
L507	1-407-239	variable inductor, 3.3 mH
L508	1-407-239	variable inductor, 3.3 mH
T501	1-433-140	transformer, bias osc

CAPACITORS

C501	1-121-398	10 μF	25 V	electrolytic
C502	1-105-833-12	0.01 μF	50 V	mylar
C503	1-105-841-12	0.047 μF	50 V	mylar
C504	1-107-252	390 pF	1000 V	silvered mica
C505	1-121-404	33 μF	25 V	electrolytic
C506	1-105-825-12	0.0022 μF	50 V	mylar
C507	1-105-825-12	0.0022 μF	50 V	mylar
C508	1-107-144	100 pF	1000 V	silvered mica
C509	1-141-034	30 - 200 pF		trimmer
C510	1-141-034	30 - 200 pF		trimmer
C511	1-141-034	30 - 200 pF		trimmer
C512	1-141-034	30 - 200 pF		trimmer
C513	1-141-034	30 - 200 pF		trimmer
C514	1-107-018	270 pF	500 V	silvered mica
C515	1-107-018	270 pF	500 V	silvered mica
C518	1-107-006	330 pF	500 V	silvered mica

Ref. No. Part No. Description

RESISTORS

All resistors are 1/4W and carbon type, unless otherwise indicated.

R501	1-242-617	4.7 Ω
R502	1-242-617	4.7 Ω
R503	1-242-711	39 kΩ
R504	1-242-625	10 Ω
R505	1-242-691	5.6 kΩ
R506	1-242-689	4.7 kΩ
R507	1-242-721	100 kΩ
R508	1-242-697	10 kΩ
R509	1-242-705	22 kΩ
R510	1-242-715	56 kΩ
R511	1-242-711	39 kΩ
R512	1-242-677	1.5 kΩ
R513	1-242-705	22 kΩ
R514	1-242-689	4.7 kΩ
R515	1-242-651	120 Ω
R516	1-242-625	10 Ω
R517	1-242-625	10 Ω
R518	1-242-625	10 Ω

SWITCHES

S101	1-514-813	slide; DIRECTION
S102		- described in PB AMP CIRCUIT -
S103	1-514-813	slide; REC
S104	1-514-813	slide; REC

POWER SUPPLY CIRCUIT

SEMICONDUCTORS

Q601	transistor,	2SD291
Q602	transistor,	2SC634A
Q603	transistor,	2SC634A
Q604	transistor,	2SC634A
D601-1	diode,	CD-2
D601-2	diode,	CD-2
D602	diode,	10D-2
D603	diode,	10D-05
D608	diode,	1T263-40
D609	diode,	10D-05
D612	diode,	10D-05
D613	diode,	10D-05
D614	diode,	10D-05
D615	diode,	10D-05

CAPACITORS

C601	1-121-398	10 μF	25 V electrolytic
------	-----------	-------	-------------------

Ref. No. Part No. Description

C602	1-121-388	1000 μF	35 V electrolytic
C603	1-121-388	1000 μF	35 V electrolytic
C610	1-121-405	33 μF	50 V electrolytic
C611	1-121-404	33 μF	25 V electrolytic
C612	1-105-676-12	0.018 μF	50 V mylar
C613	1-105-673-12	0.01 μF	50 V mylar
C614	1-121-391	1 μF	50 V electrolytic
C615	1-105-673-12	0.01 μF	50 V mylar

RESISTORS

R601	1-242-701	15 kΩ	1/4W carbon
R602	1-242-697	10 kΩ	1/4W carbon
R603	1-221-630	20 kΩ (B),	semi-fixed
R604	1-242-697	10 kΩ	1/4W carbon
R605	1-242-707	27 kΩ	1/4W carbon
R606	1-244-825	10 Ω	1/2W carbon
R611	1-206-127	470 Ω	2 W carbon
R612	1-242-713	47 kΩ	1/2W carbon
R613	1-242-683	2.7 kΩ	1/4W carbon
R614	1-242-689	4.7 kΩ	1/4W carbon
R615	1-244-857	220 Ω	1/2W carbon
R616	1-242-683	2.7 kΩ	1/4W carbon
R617	1-242-737	470 kΩ	1/4W carbon

MISCELLANEOUS

CP601-604	1-231-057	encapsulated component C-R 0.033 μF + 120 Ω
RY601	1-515-127	relay, DC 24 V

RELAY CIRCUIT

SEMICONDUCTORS

D604	diode,	10D-6
D605	diode,	10D-2
D606	diode,	10D-2
D610	diode,	10D-2
Pth601	thermistor	

CAPACITOR

C604	1-121-810	470 μF	50 V electrolytic
------	-----------	--------	-------------------

RESISTORS

R607	1-242-725	150 kΩ	1/4W carbon
R618	1-206-198	1 kΩ	5 W metal oxide film

MISCELLANEOUS

CP605-608	1-231-057	encapsulated component C-R 0.033 μF + 120 Ω
-----------	-----------	--

<u>Ref. No.</u>	<u>Part No.</u>	<u>Description</u>
RY602	1-515-127	relay, DC 24 V

MECHANICAL CHASSIS CIRCUIT

SEMICONDUCTORS

D607, 611		diode, 10D-6
-----------	--	--------------

TRANSFORMER

T601	1-441-730	power
------	-----------	-------

CAPACITORS

C605	1-121-709	220 μ F	200 V electrolytic
C606	1-117-082	4 μ F	250 V metalized paper
C607	1-117-082	4 μ F	250 V metalized paper
C608	1-105-839-12	0.033 μ F	50 V mylar
C609	1-105-839-12	0.033 μ F	50 V mylar
C610		- described in POWER SUPPLY CIRCUIT -	
C611		- described in POWER SUPPLY CIRCUIT -	
C612	1-117-082	4 μ F	250 V metalized paper
C708	1-121-300	2200 μ F	70 V electrolytic

RESISTORS

R608	1-227-092	1 k Ω	10W wirewound (semi-fixed)
R609	1-227-134	150 Ω	15W wirewound (semi-fixed)

SWITCHES

S601	1-514-864	micro; FWD-REV (1)
S602	1-514-864	micro; PLAY, FF-STOP (1)
S603	1-514-866	seesaw; POWER
S604	1-514-864	micro; PLAY-FF, STOP (1)
S605	1-514-864	micro; PLAY, FF-STOP (2)
S606	1-514-865	micro; STOP
S607	1-514-865	micro; FF (1)
S608	1-514-865	micro; PLAY (1)
S609	1-514-864	micro; AUTO SHUT-OFF
S610	1-514-864	micro; PLAY, FF-STOP (3)
S611	1-514-864	micro; FF (2)
S612	1-514-864	micro; PLAY-FF, STOP (2)
S613	1-514-706	leaf; PLAY-FF, STOP (3)
S614	1-514-864	micro; PLAY, FF-STOP (4)
S615, 616	1-514-699	leaf; PLAY (2), (3) Serial No. up to 10,550
S615, 616	1-514-423	micro Serial No. 10,551 and later.
S617	1-514-633	slide; CONT REV/REV/REV OFF
S618	1-514-864	micro; AUTO OFF
S619	1-514-864	micro; FWD-REV (2)
S620	1-514-707	leaf; PLAY-FF, STOP (4)

<u>Ref. No.</u>	<u>Part No.</u>	<u>Description</u>
-----------------	-----------------	--------------------

MISCELLANEOUS

CP609-613	1-231-057	encapsulated component C-R 0.033 μ F + 120 Ω
CP614-617	1-101-534	encapsulated component C-R 0.1 μ F + 120 Ω
CP618-621	1-231-057	encapsulated component C-R 0.033 μ F + 120 Ω
CP622, 623	1-101-534	encapsulated component C-R 0.1 μ F + 120 Ω
PM601	1-454-075	plunger solenoid
PM602, 603	1-454-074	plunger solenoid
	1-534-487	cord, power
	1-535-045	terminal, contact; printed circuit board
	1-536-029	terminal, 4p mold, push
	1-535-506	point terminal
	1-536-146	terminal strip 1L1 (C type)
	1-536-179	terminal strip 1L1 (C type)
	1-536-181	terminal strip 2L1 (C type)
	1-536-183	terminal strip 2L3 (C type)
M1	8-836-214-02	motor, capstan (UC-214G)
M2, 3	8-836-624-11	motor, reel (UC-624K)
M4	8-833-012-11	motor, fan (IS-024A)

POWER AMP CIRCUIT

SEMICONDUCTORS

Q701, 801	transistor, 2SC633A
Q702, 802	transistor, 2SC633A
Q703 ~ 706 Q803 ~ 806	transistor, 2SC634A
Q709, 809	transistor, 2SC634A
D701	diode, 1T264-41
D702~705	diode, 10D-2

CAPACITORS

C721, 821	1-121-391	1 μ F	50 V electrolytic
C722, 822	1-105-821-12	0.001 μ F	50 V mylar
C723, 823	1-121-391	1 μ F	50 V electrolytic
C724, 824	1-121-391	1 μ F	50 V electrolytic
C725, 825	1-107-111	15 pF	50 V silvered mica
C726, 826	1-121-398	10 μ F	25 V electrolytic
C727, 827	1-121-391	1 μ F	50 V electrolytic
C728, 828	1-121-415	100 μ F	16 V electrolytic
C729, 829	1-121-391	1 μ F	50 V electrolytic
C730, 830	1-107-107	10 pF	50 V silvered mica
C731, 831	1-121-810	470 μ F	50 V electrolytic
C732, 832	1-105-821-12	0.001 μ F	50 V mylar
C733, 833	1-105-821-12	0.001 μ F	50 V mylar
C834	1-121-417	100 μ F	50 V electrolytic

Ref. No. Part No. Description

RESISTORS

All resistors are 1/4W and carbon type, unless otherwise indicated.

R721, 821	1-242-737	470 kΩ
R722, 822	1-242-737	470 kΩ
R723, 823	1-242-697	10 kΩ
R724, 824	1-242-683	2.7 kΩ
R725, 825	1-242-729	220 kΩ
R726, 826	1-242-719	82 kΩ
R727, 827	1-242-711	39 kΩ
R728, 828	1-242-701	15 kΩ
R729, 829	1-242-637	33 Ω
R730, 830	1-242-669	680 Ω
R731, 831	1-242-683	2.7 kΩ
R732, 832	1-242-683	2.7 kΩ
R733, 833	1-242-689	4.7 kΩ
R734, 834	1-222-775	22 kΩ (B), semi-fixed
R735, 835	1-242-717	68 kΩ
R736, 836	1-242-685	3.3 kΩ
R737, 837	1-242-681	2.2 kΩ
R738, 838	1-242-715	56 kΩ
R739, 839	1-242-673	1 kΩ
R740, 840	1-242-673	1 kΩ
R741, 841	1-244-801	1 Ω 1/2W
R742, 842	1-244-801	1 Ω 1/2W
R743, 843	1-244-801	1 Ω 1/2W
R744, 844	1-244-801	1 Ω 1/2W
R745, 845	1-242-659	270 Ω
R746, 846	1-242-649	100 Ω
R747, 847	1-242-679	1.8 kΩ
R748, 848	1-242-701	15 kΩ
R749, 849	1-242-721	100 kΩ
R750, 850	1-242-701	15 kΩ
R751, 851	1-242-649	100 Ω
R752, 852	1-242-649	100 Ω
R753, 853	1-242-663	390 Ω
R754	1-242-657	220 Ω
R755	1-242-723	120 kΩ
R756	1-242-717	68 kΩ
R757	1-206-093	1 kΩ 1 W metal oxide film
R758	1-242-625	10 Ω
R759	1-242-625	10 Ω

POWER AMP CHASSIS

SEMICONDUCTORS

Q707, 807	transistor,	2SC895
Q708, 808	transistor,	2SC895
TH701, 801	thermistor,	S-10K

Ref. No. Part No. Description

RESISTORS

R701, 801		- described in TONE CONTROL CIRCUIT -
R702, 802	1-221-917	50 kΩ (A)/50 kΩ (A) variable (TREBLE)
R703, 803		- described in TONE CONTROL CIRCUIT -
R704, 804	1-221-917	50 kΩ (A)/50 kΩ (A) variable (BASS)
R707, 807	1-221-917	50 kΩ (A)/50 kΩ (A) variable (VOL)
R708, 808		- described in TONE CONTROL CIRCUIT -
R709	1-222-499	500 kΩ variable (BALANCE)

SWITCHES

S701	1-514-866	seesaw, power
S702	1-514-870	rotary, MODE
S703	1-514-869	lever, SP SELECT

JACKS

J702	1-507-282	binaural, HEADPHONE
CNJ601	1-509-341	AC OUTLET
VS601	1-509-427	socket, power voltage selector
CNJ701	1-534-614	connector with cord
CNP701	1-534-615	connector with cord

MISCELLANEOUS

SP701, 801	1-502-295	speaker (32 Ω 4 W)
PL7	1-518-093-21	lamp (2 V), power amp
F1	1-532-102	fuse, tube (3.15 A)
	1-533-048	holder, fuse

TONE CONTROL CIRCUIT

CAPACITORS

C701, 801	1-105-665-12	0.0022 μF	50 V	mylar
C702, 802	1-105-675-12	0.015 μF	50 V	mylar
C703, 803	1-105-677-12	0.022 μF	50 V	mylar
C704, 804	1-105-685-12	0.1 μF	50 V	mylar

RESISTORS

R701, 801	1-242-677	1.5 kΩ	1/4W	carbon
R702, 802		- described in POWER AMP CHASSIS -		
R703, 803	1-242-695	8.2 kΩ	1/4W	carbon

Ref. No. Part No. Description

R704, 804		- described in POWER AMP CHASSIS -
R705, 805	1-242-683	2.7 kΩ 1/4W carbon
R706, 806	1-242-693	6.8 kΩ 1/4W carbon
R707, 807		- described in POWER AMP CHASSIS -
R708, 808	1-242-701	15 kΩ 1/4W carbon

SERVO CONTROL CIRCUIT

SEMICONDUCTORS

Q901	transistor,	2SC867
D901	diode,	10D-2
D902 ⁻¹⁾ ₋₂₎	diode,	CD-2
D903 ⁻¹⁾ ₋₂₎	diode,	CDR-2
IC901	integrated circuit,	CX-032

CAPACITORS

C901	1-105-843-12	0.068 μF	50 V	mylar
C902	1-108-551-11	0.15 μF	50 V	mylar
C903	1-105-821-12	0.001 μF	50 V	mylar
C904	1-121-398	10 μF	25 V	electrolytic
C905	1-121-398	10 μF	25 V	electrolytic
C906	1-121-416	100 μF	25 V	electrolytic
C907	1-121-403	33 μF	16 V	electrolytic
C908	1-121-409	47 μF	16 V	electrolytic
C909	1-127-306	6.8 μF	16 V	electrolytic
C910	1-105-835-12	0.015 μF	50 V	mylar

Ref. No. Part No. Description

C911	1-121-818	10 μF	160 V	electrolytic
------	-----------	-------	-------	--------------

RESISTORS

All resistors are 1/4W and carbon type, unless otherwise indicated.

R901	1-221-401	10 kΩ (B),	semi-fixed
R902	1-242-709	33 kΩ	
R903	1-221-952	20 kΩ (B),	semi-fixed
R904	1-242-717	68 kΩ	
R905	1-221-953	50 kΩ (B),	semi-fixed
R906	1-242-724	130 kΩ	
R907	1-242-691	5.6 kΩ	
R908	1-242-680	2 kΩ	
R909	1-242-689	4.7 kΩ	
R910	1-242-639	39 Ω	
R911	1-244-867	560 Ω	1/2W
R912	1-242-697	10 kΩ	
R913	1-242-691	5.6 kΩ	
R914	1-242-683	2.7 kΩ	
R915	1-242-677	1.5 kΩ	
R916	1-242-702	16 kΩ	
R917	1-242-689	4.7 kΩ	
R918	1-242-657	220 Ω	
R919	1-242-705	22 kΩ	
R921	1-242-649	100 Ω	

SWITCH

S901	1-514-323	slide; TAPE SPEED
------	-----------	-------------------

6-2. HEAD DECK - TOP VIEW -

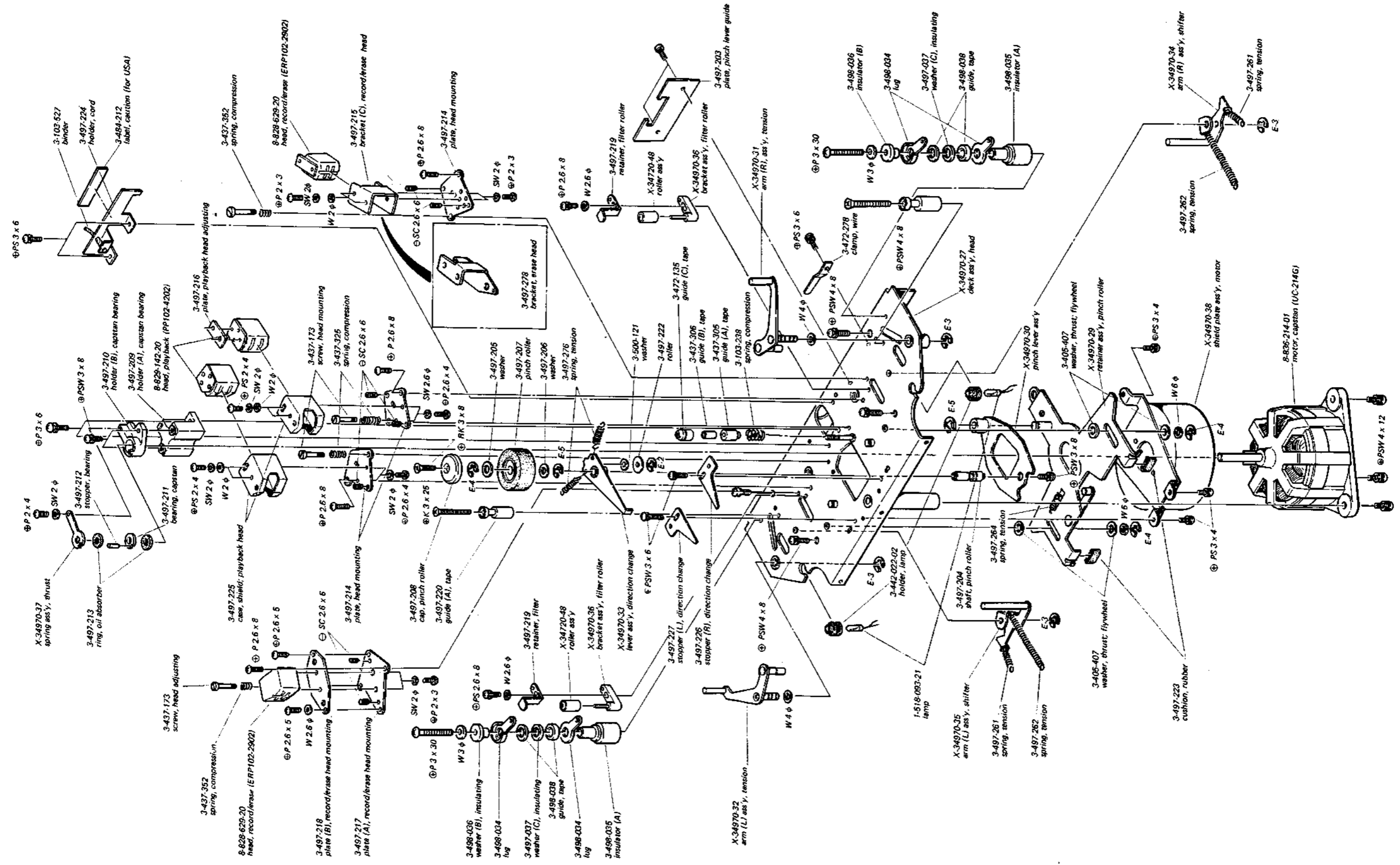

6-4. AMPLIFIER CHASSIS - TOP VIEW -

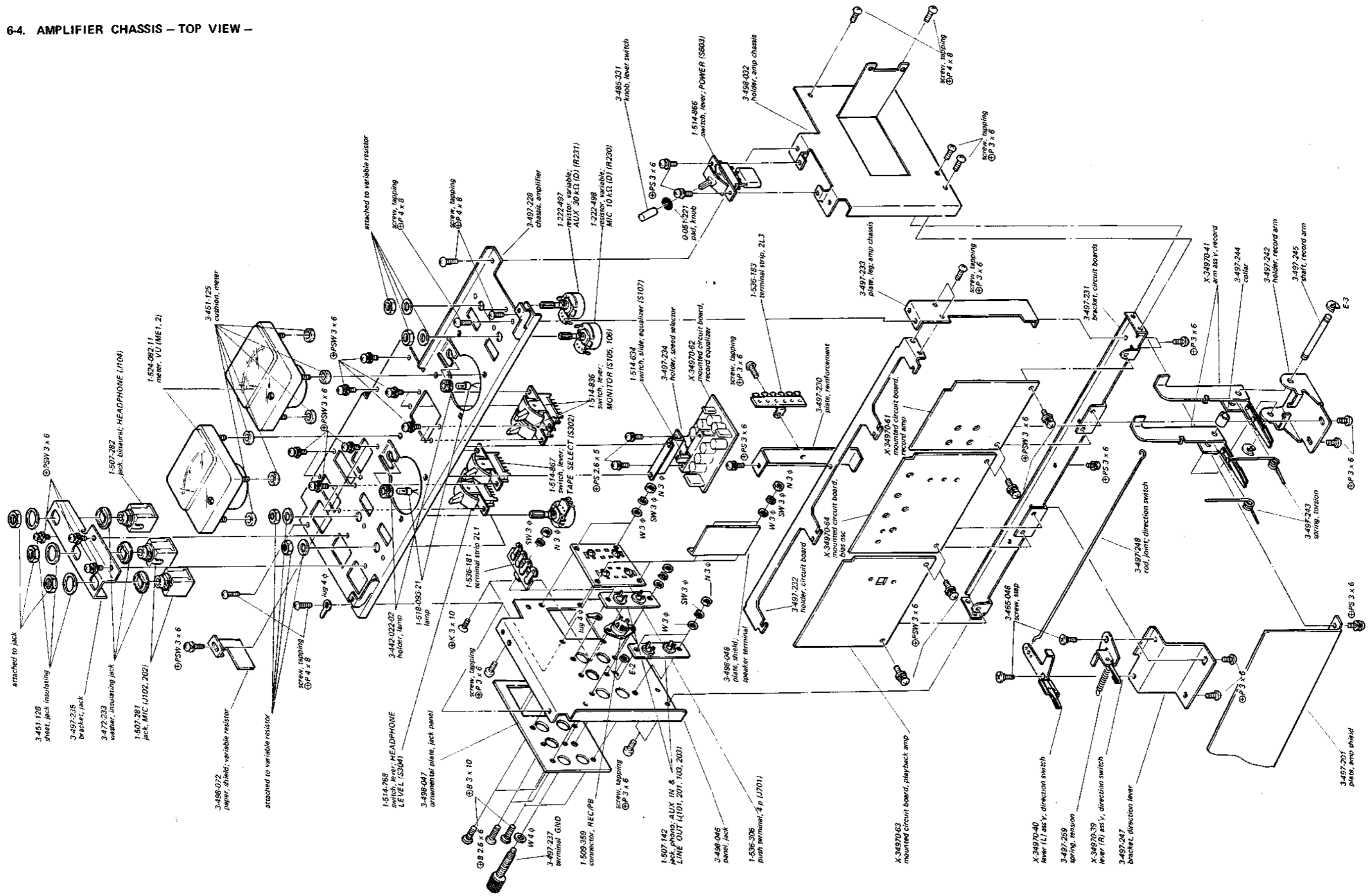

6.6. CHASSIS – TOP VIEW – (2)

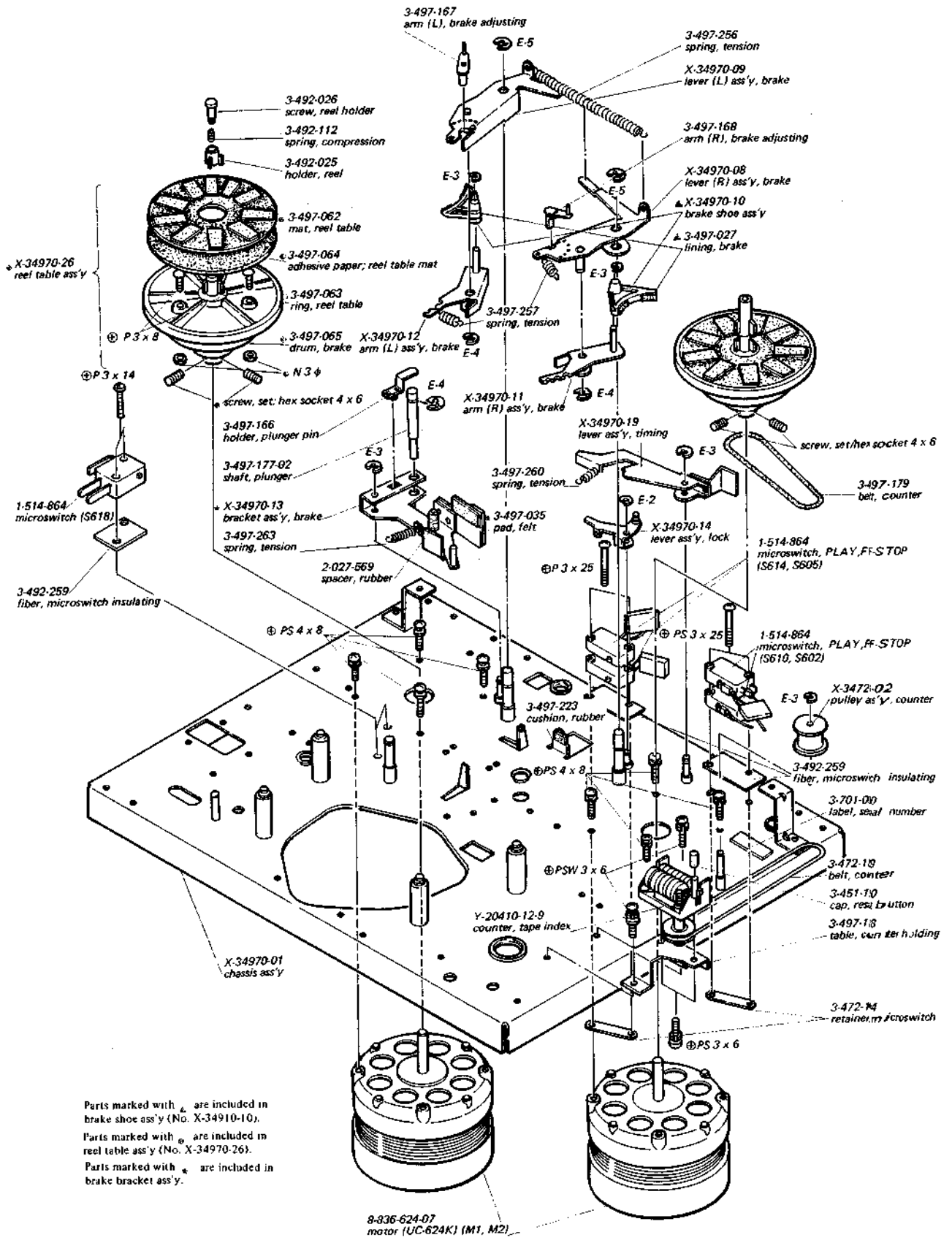

Parts marked with Δ are included in brake shoe ass'y (No. X-34910-10).
 Parts marked with \circ are included in reel table ass'y (No. X-34970-26).
 Parts marked with \oplus are included in brake bracket ass'y.

6-7. CHASSIS – TOP VIEW – (3)

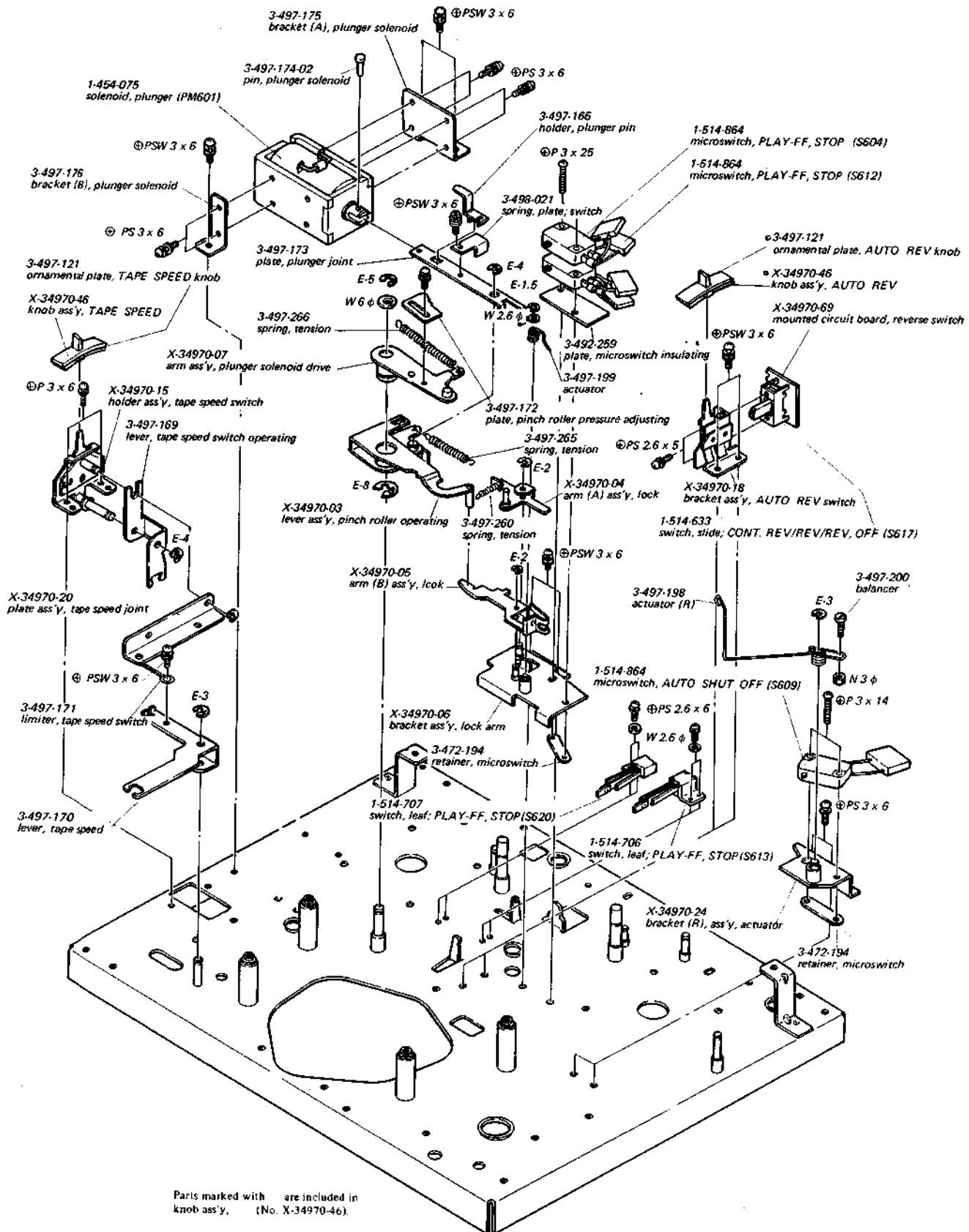

6-8. CHASSIS - BOTTOM VIEW -

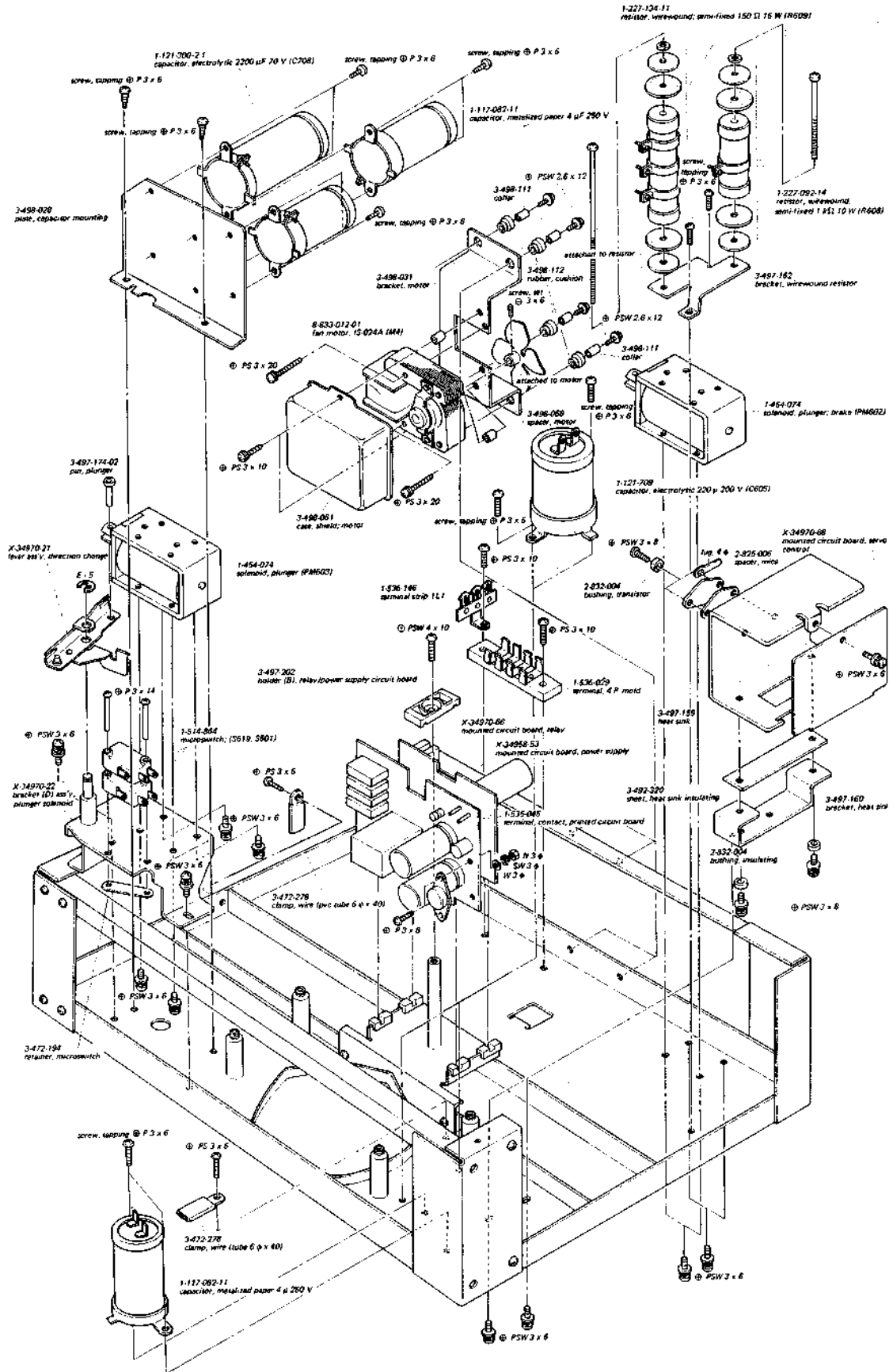

6-9. PACKING

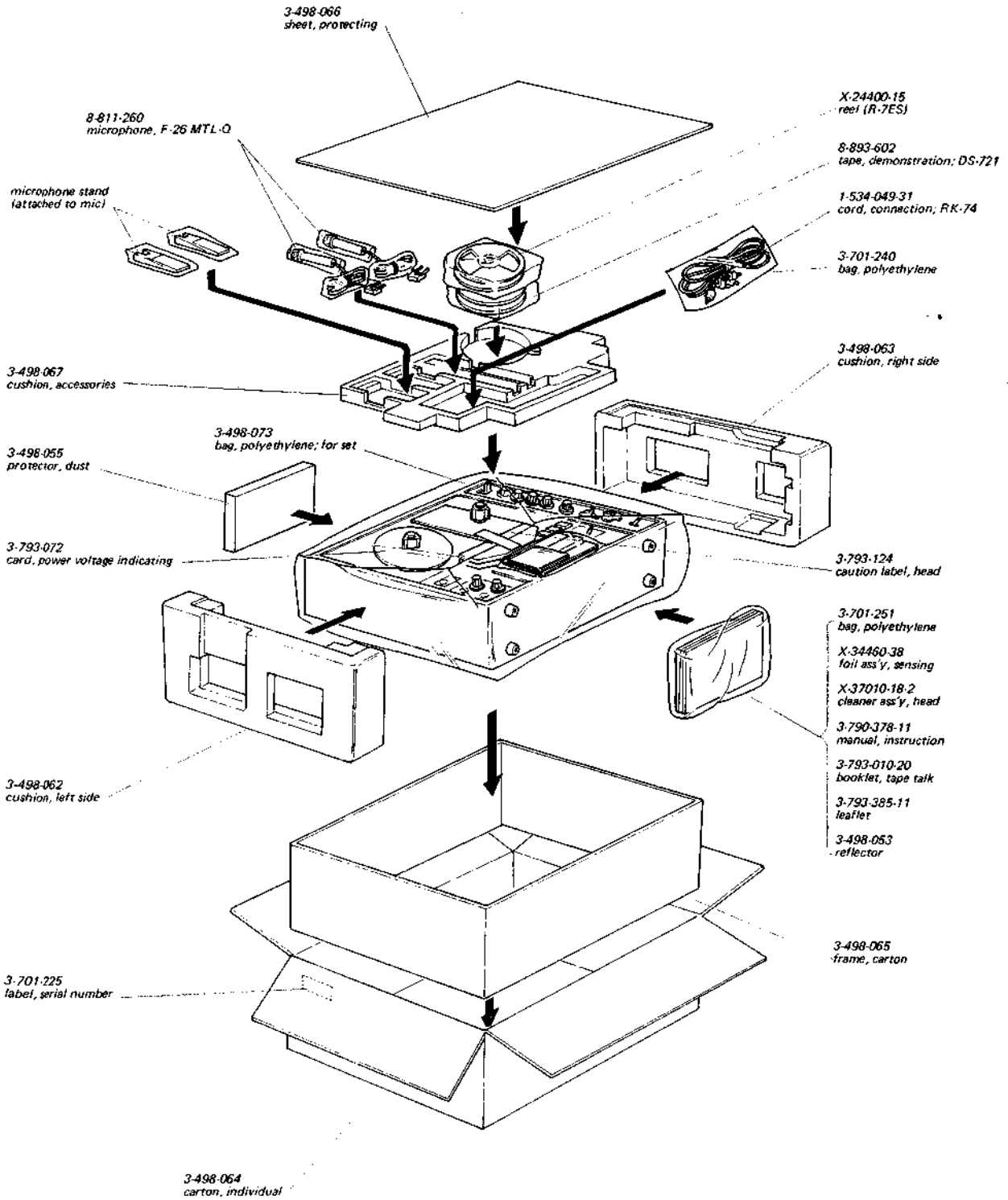

SECTION 7 HARDWARE

Part No. Description

SCREWS

7-621-259-25	⊕ P 2.6 x 4
7-621-259-35	⊕ P 2.6 x 5
7-621-259-55	⊕ P 2.6 x 8
7-621-560-55	⊕ K 2.6 x 25
7-621-712-55	⊖ SC 2.6 x 6
7-621-770-50	⊕ B 2.6 x 6
7-628-254-05	⊕ PS 2.6 x 5
7-628-254-15	⊕ PS 2.6 x 6
7-628-254-25	⊕ PS 2.6 x 8
	⊕ PS 2.6 x 12
7-682-123-01	⊕ P 2 x 3
7-682-124-01	⊕ P 2 x 4
7-682-125-01	⊕ P 2 x 5
7-682-149-01	⊕ P 3 x 10
7-682-150-01	⊕ P 3 x 12
7-682-151-01	⊕ P 3 x 12
7-682-154-01	⊕ P 3 x 25
7-682-155-01	⊕ P 3 x 30
7-682-156-01	⊕ P 3 x 35
7-682-159-04	⊕ P 4 x 8, tapping
7-682-165-01	⊕ P 4 x 16
7-682-249-01	⊕ K 3 x 10
7-682-249-14	⊕ K 3 x 10
7-682-348-13	⊕ RK 3 x 8
7-682-349-13	⊕ RK 3 x 10
7-682-369-04	⊕ RK 4 x 35
7-682-547-14	⊕ B 3 x 6
7-682-548-15	⊕ B 3 x 8
7-682-549-14	⊕ B 3 x 10
7-682-645-01	⊕ PS 3 x 4
7-682-647-01	⊕ PS 3 x 6
7-682-649-01	⊕ PS 3 x 10
7-682-651-01	⊕ PS 3 x 14
7-682-653-01	⊕ PS 3 x 20
7-682-661-01	⊕ PS 4 x 8
7-682-947-01	⊕ PSW 3 x 6

Part No. Description

7-682-948-01	⊕ PSW 3 x 8
7-682-961-01	⊕ PSW 4 x 8
7-682-962-01	⊕ PSW 4 x 10
7-682-963-01	⊕ PSW 4 x 12
7-683-247-01	⊖ SC 4 x 6, with hex. socket
7-685-145-31	⊕ P 3 x 6, tapping
7-685-146-31	⊕ P 3 x 8, tapping

WASHERS

7-623-105-12	2 φ
7-623-107-02	2.6 φ (small)
7-623-107-12	2.6 φ (middle)
7-623-108-12	3 φ
7-623-110-12	4 φ
7-623-116-12	6 φ
7-623-205-21	2 φ spring
7-623-207-21	2.6 φ spring
7-623-208-21	3 φ spring

LUG PLATES

7-623-508-01	3 φ
7-623-510-01	4 φ

RETAINING RINGS

7-624-102-01	E - 1.5
7-624-104-01	E - 2
7-624-106-01	E - 3
7-624-108-01	E - 4
7-624-109-01	E - 5
7-624-112-01	E - 8
7-624-118-01	E - 2.5

NUT

7-684-013	3 φ
-----------	-----

Hardware Nomenclature

<p>P — Pan Head Screw </p> <p>K — Flat Countersunk Head Screw </p> <p>B — Binding Head Screw </p> <p>RK — Oval Countersunk Head Screw </p> <p>T — Truss Head Screw </p> <p>R — Round Head Screw </p> <p>F — Flat Fillister Head Screw </p> <p>SC — Set Screw </p>	<p>E — Retaining Ring (E Washer) </p> <p style="padding-left: 40px;">W — Washer</p> <p style="padding-left: 40px;">SW — Spring Washer</p> <p style="padding-left: 40px;">LW — Lock Washer</p> <p style="padding-left: 40px;">N — Nut</p> <p>Example</p> <p>⊕ P 3 x 10</p> <p style="padding-left: 20px;">— Type of Slot</p> <p style="padding-left: 40px;">— Length in mm (L)</p> <p style="padding-left: 40px;">— Diameter in mm (D)</p> <p style="padding-left: 20px;">— Type of Head</p>
---	---