

TC-645

UK Model
AEP Model



STEREO TAPECORDER

SPECIFICATIONS

Power Requirements:	AC 110 V, 127 V, 220 V, 240 V, 50 Hz	Inputs:	Two MICROPHONE inputs Impedance: low impedance Maximum sensitivity: -72 dB (0.2 mV)
Power Consumption:	110 W		Two LINE INputs Impedance: 100 k Ω Maximum sensitivity: -22 dB (0.06 V)
Record Bias Frequency:	Approx. 160 kHz	Outputs:	Two LINE OUTputs Load impedance: more than 10 k Ω Output level: 0 dB (0.775 V) with 100 k Ω load
Track System:	Four track two channel stereo and mono		HEADPHONE output Load impedance: 8 Ω
Reel Size:	7" maximum	Semiconductors:	19 transistors, 15 diodes and 4 ICs
Tape Speed:	19 cm/s (7 $\frac{1}{2}$ ips) 9.5 cm/s (3 $\frac{3}{4}$ ips)	Record Head:	RF140-2902 (70 Ω /1 kHz)
Frequency Response:	SPECIAL (SONY SLH tape) 19 cm/s (7 $\frac{1}{2}$ ips): 20 ~ 30,000 Hz (NAB) 30 ~ 24,000 Hz (DIN) 9.5 cm/s (3 $\frac{3}{4}$ ips): 20 ~ 20,000 Hz (NAB) 40 ~ 16,000 Hz (DIN)	Playback Head:	PF140-4202 (1 k Ω /1 kHz)
Signal-to-Noise Ratio:	NORMAL 53 dB or better SPECIAL 56 dB or better	Erase Head:	EF18-2902A2 (1.6 k Ω /160 kHz)
Distortion:	1.2%	Motor:	IC-624H1 (capstan) UC-624K (take-up and supply reel)
Wow and Flutter:	19 cm/s (7 $\frac{1}{2}$ ips): 0.07% (RMS) weighted (NAB) \pm 0.09% (DIN) 9.5 cm/s (3 $\frac{3}{4}$ ips): 0.11% (RMS) weighted (NAB) \pm 0.12% (DIN)	Dimensions:	378 (w) x 370 (h) x 224 (d) mm 14 $\frac{7}{8}$ (w) x 14 $\frac{5}{8}$ (h) x 8 $\frac{7}{8}$ (d) inches
		Weight:	18.5 kg, 40 lb 13 oz

SONY
SERVICE MANUAL

SECTION 1
OUTLINE

1-1. BLOCK DIAGRAM
- Amp Section -

This diagram shows L-CH only.

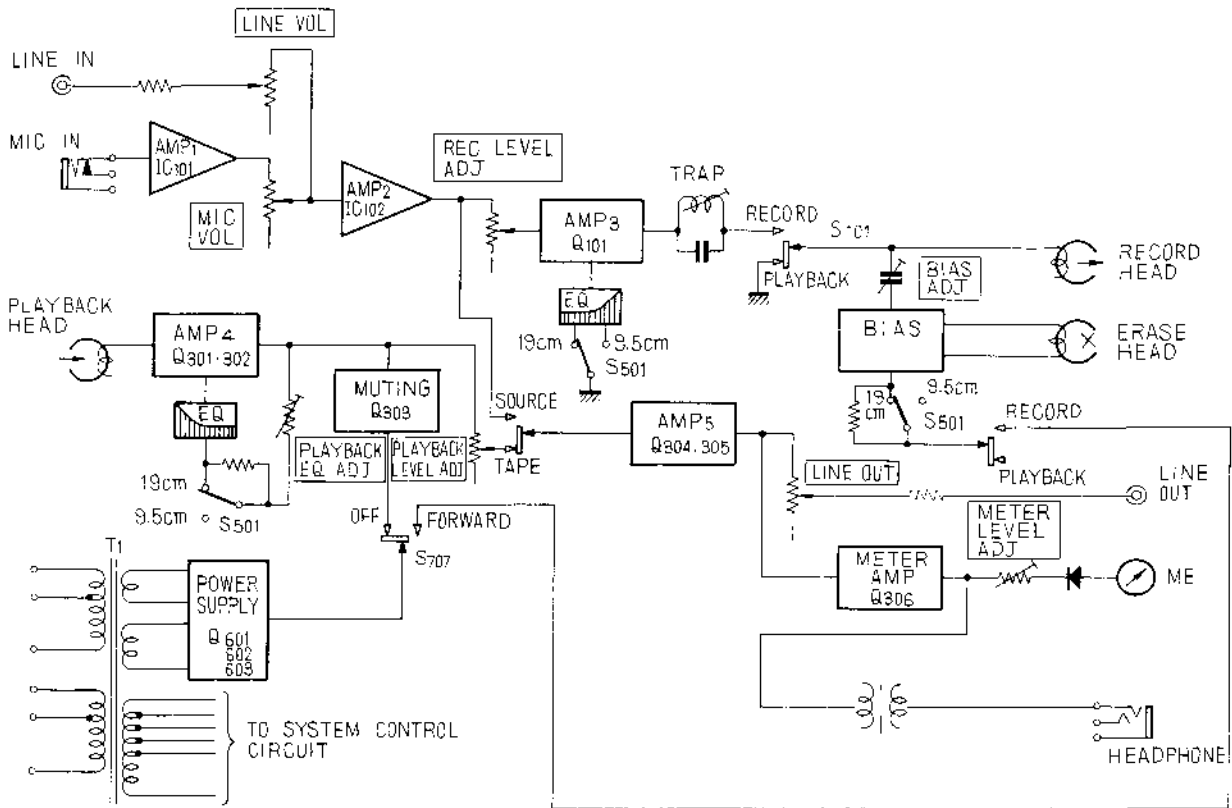

- System Control Section -

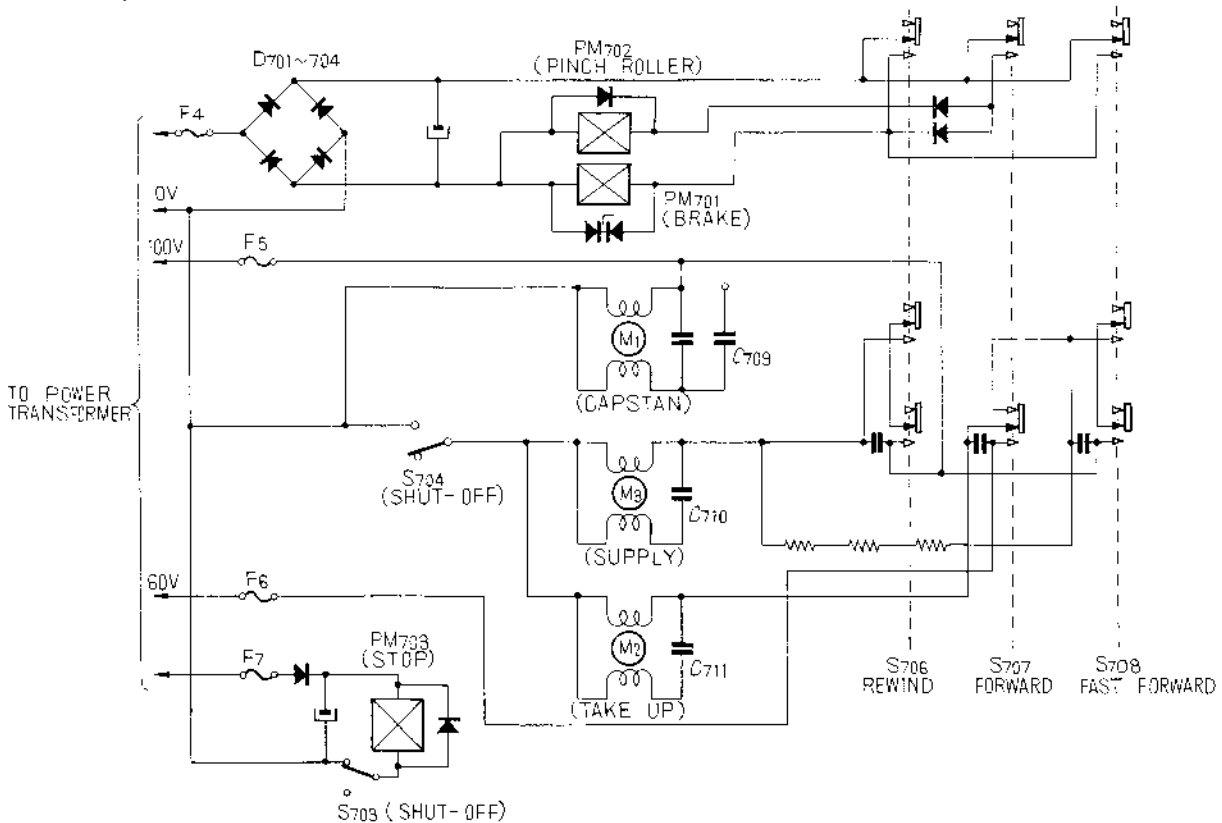

1-2. EXTERNAL VIEWS

— Top View —

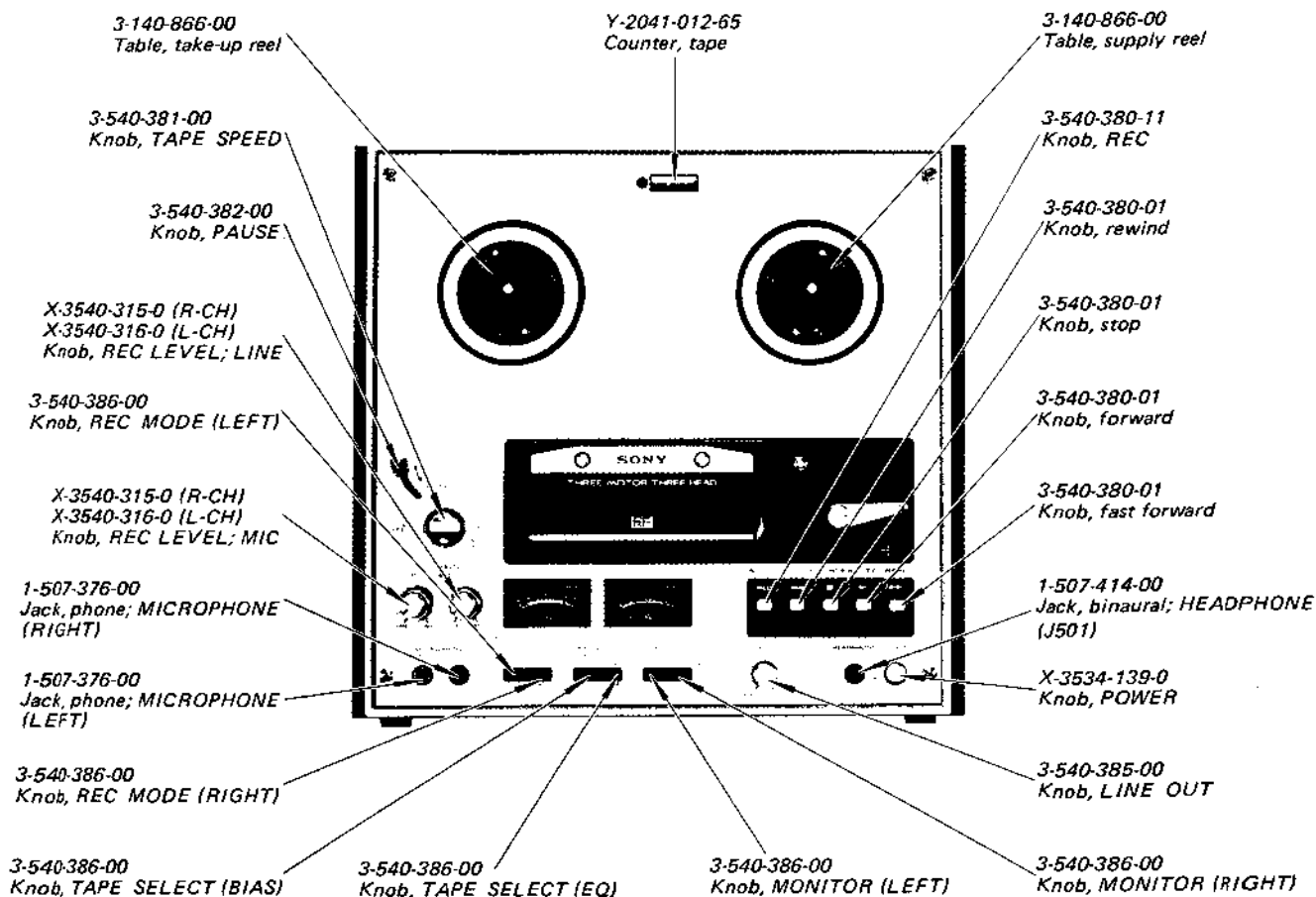

— Bottom View —

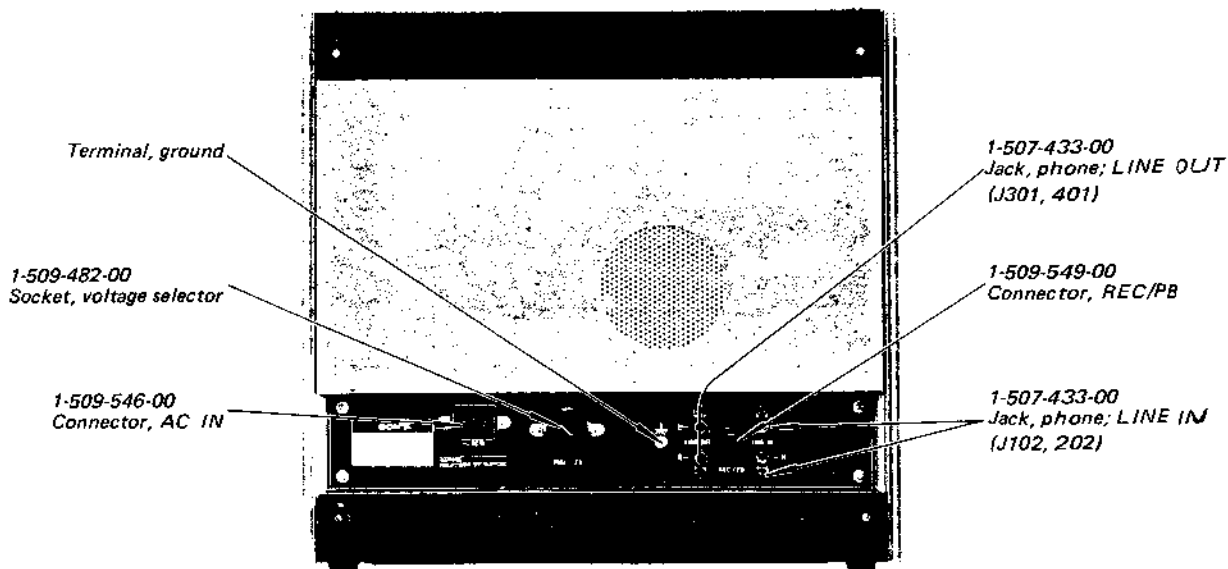

1-3. INTERNAL VIEWS

— Top View —

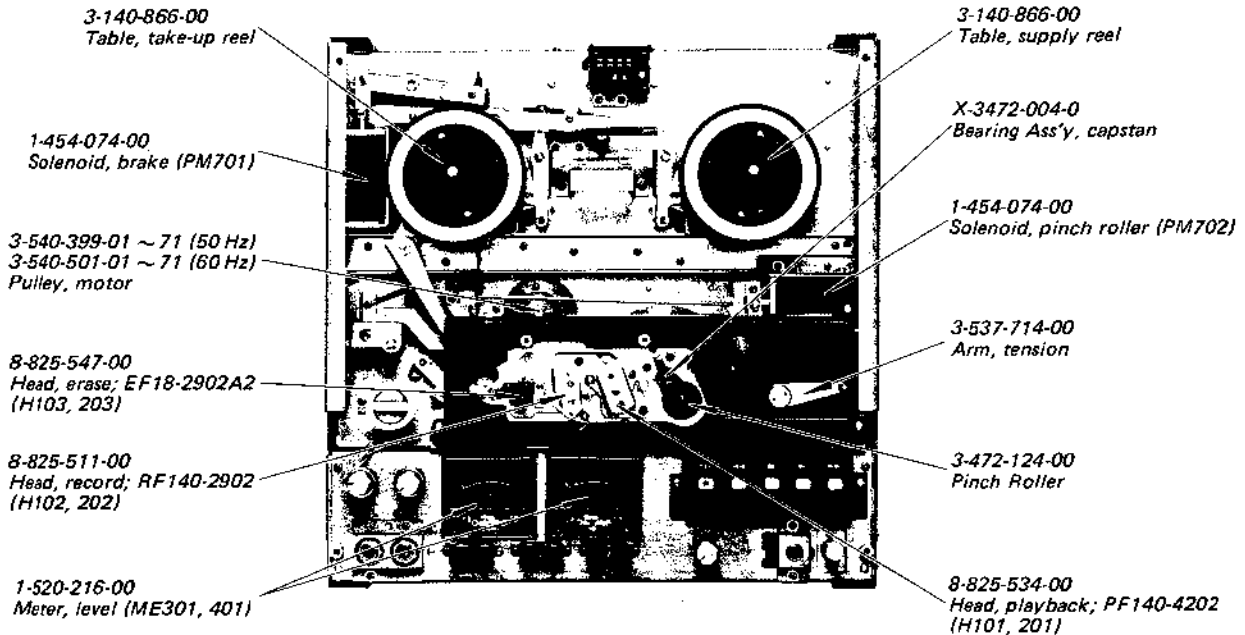

— Bottom View —

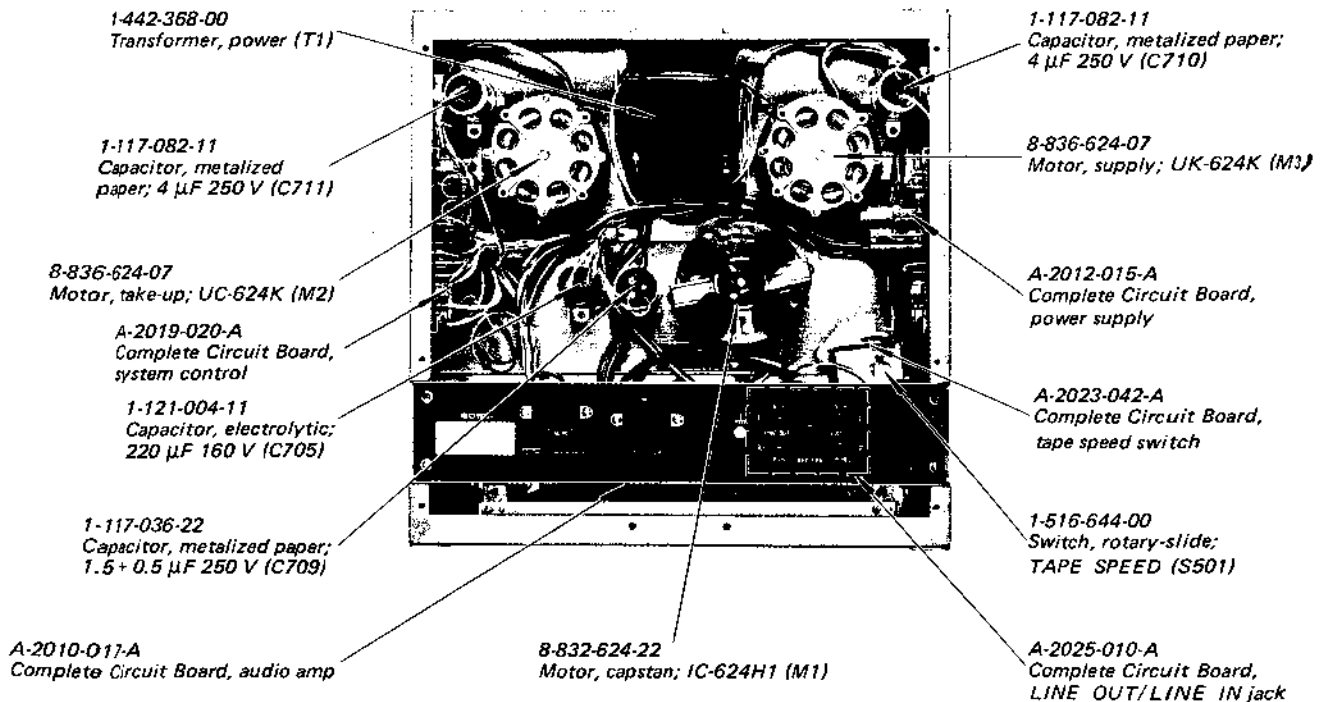

**SECTION 2
DISASSEMBLY**

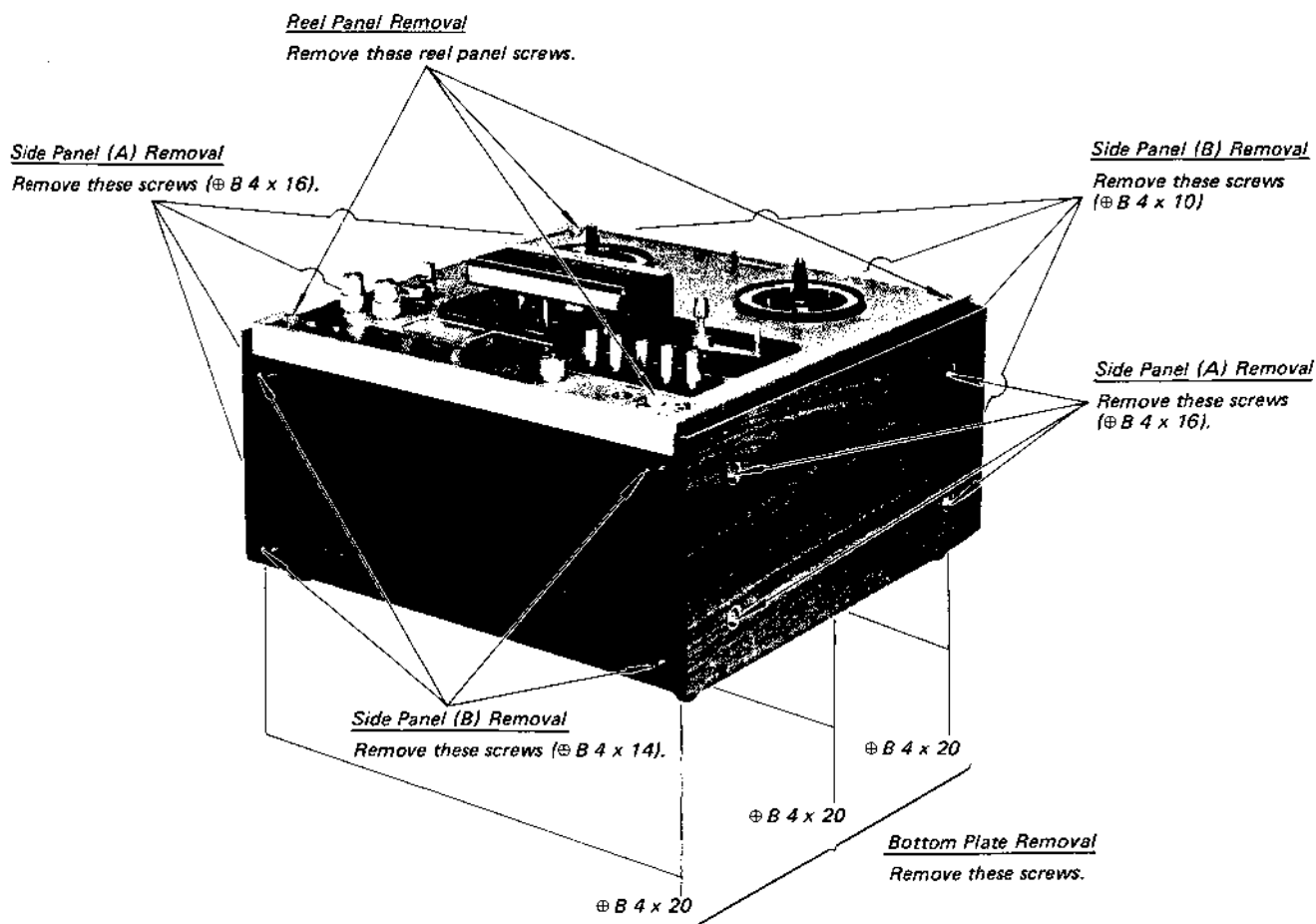

**SECTION 3
ADJUSTMENTS**

3-1. MECHANICAL ADJUSTMENTS

Reel Motor Torque Measurement

— Playback Mode —

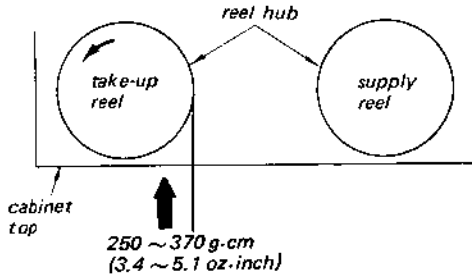

Note: When measuring torque, move spring scale in arrow direction at 9.5 - 19 cm/s (3¾ - 7½ ips).

— Fast Forward Mode —

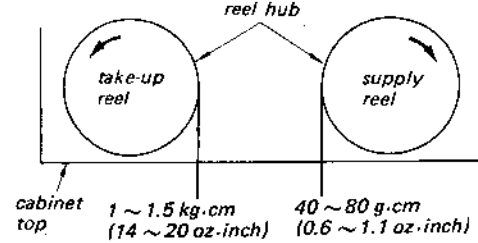

Note: Measure torque with spring scale stopped.

— Rewind Mode —

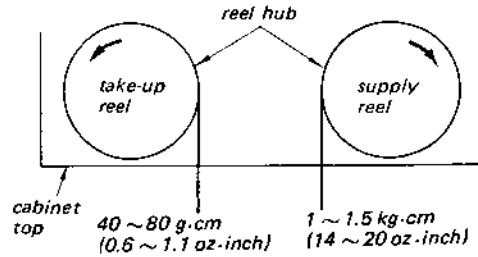

Note: Measure torque with spring scale stopped.

If necessary, change the two lead-wires connection as shown.

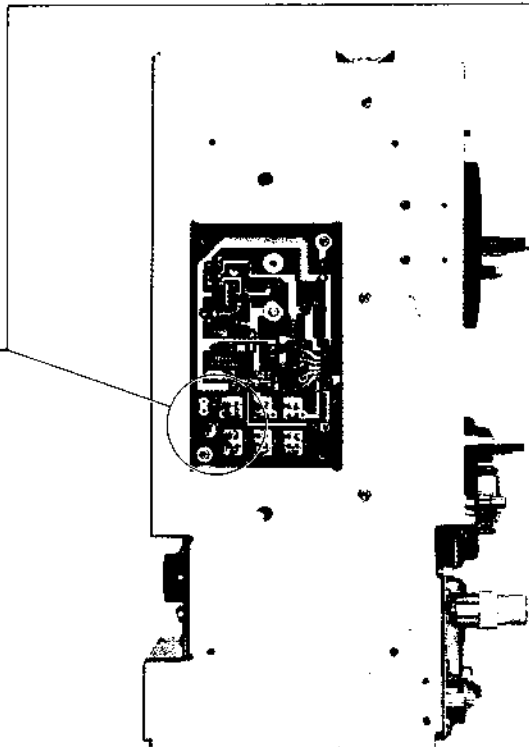
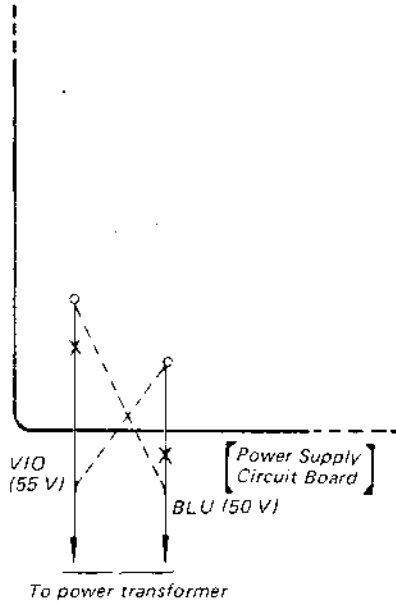

Brake Solenoid Position Adjustment

— In Playback Mode —

Loosen the screws and adjust the brake solenoid position so that the brake lever is parallel to the chassis as shown.

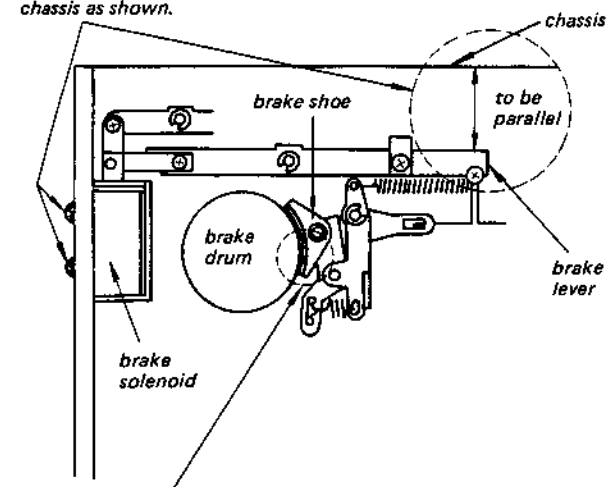

Note: After adjustment, make sure that brake shoe does not touch brake drum. If not, readjust brake solenoid position.

Tension Regulator Back-tension Adjustment

— In Playback and Fast Forward Modes —

This adjustment should be done after Tension Regulator Arm Adjustment.

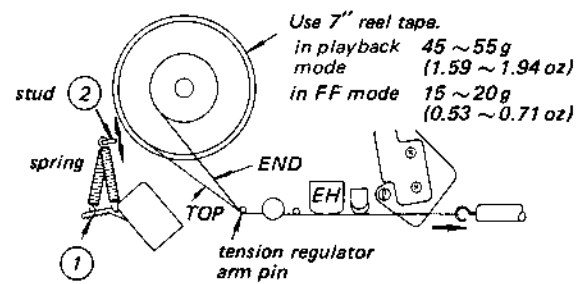

- Adjust by changing the spring hook position.
- If necessary, adjust by bending the stud or perform the tension regulator arm adjustment again.

Reel Table Adjustment

— In Playback and Rewind Modes —

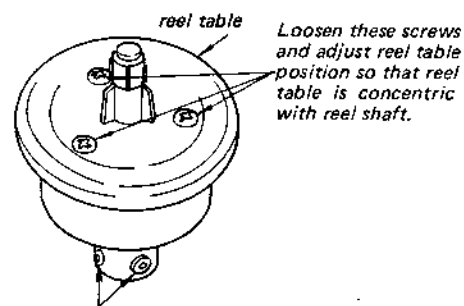

Loosen these set screws and adjust reel table height so that tape is wound at center between reel flanges.
 Note: Use hex-key wrench.

Pinch Roller Solenoid Position Adjustment

— In Playback Mode —

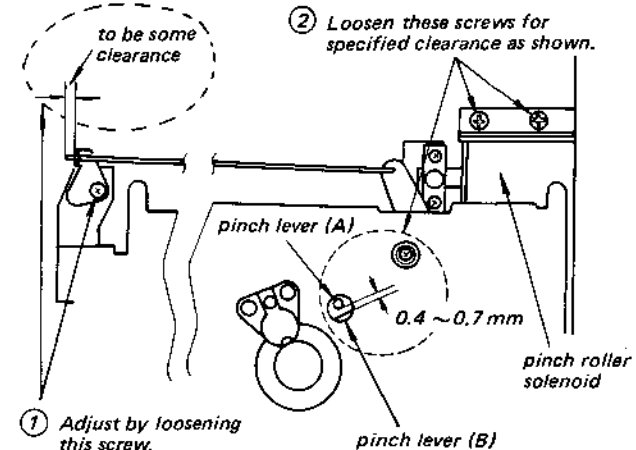

Tension Regulator Arm Adjustment

— In Stop Mode —

- Loosen the adjusting screw and adjust the tension regulator position so that the clearance shown is 8 mm (5/16") after having turned supply reel table counterclockwise by hand.

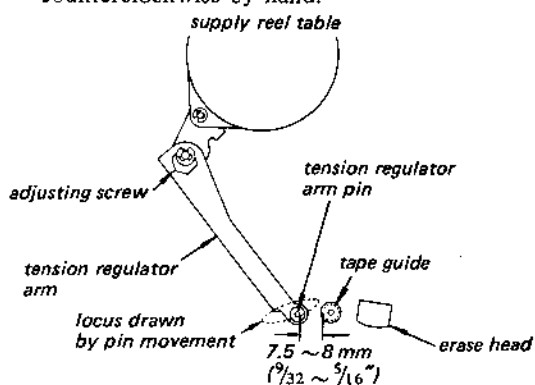

- Tape should be in contact with tension regulator pin uniformly at beginning and end portion of it.

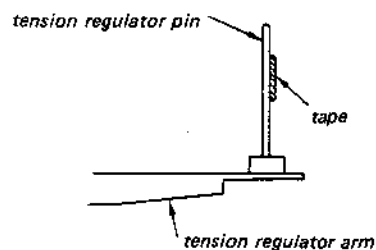

Scrape Flutter Filter Roller Position Adjustment

— In Playback Mode —

- Thread a tape, and make sure that roller rotates.
- Adjust the adjusting screw so that tape sufficiently contacts the roller, and make sure that lengthwise play of the roller is as specified, at 9.5 cm/s (3 3/4 ips) tape speed.

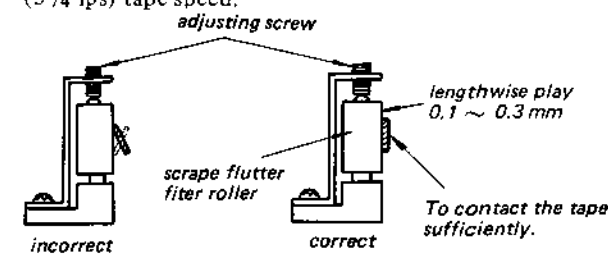

Idler Position Adjustment

— In Playback Mode —

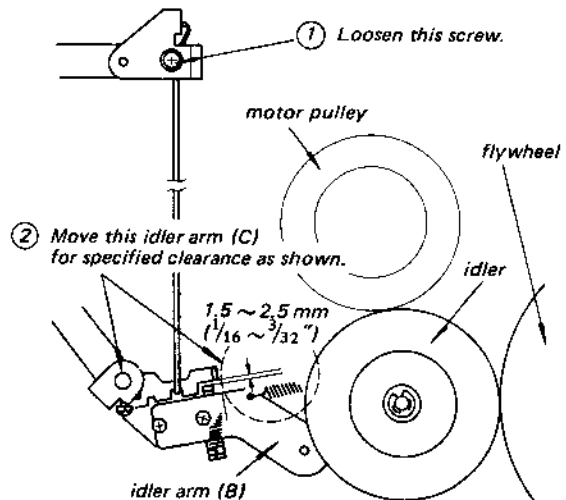

— In Stop Mode —

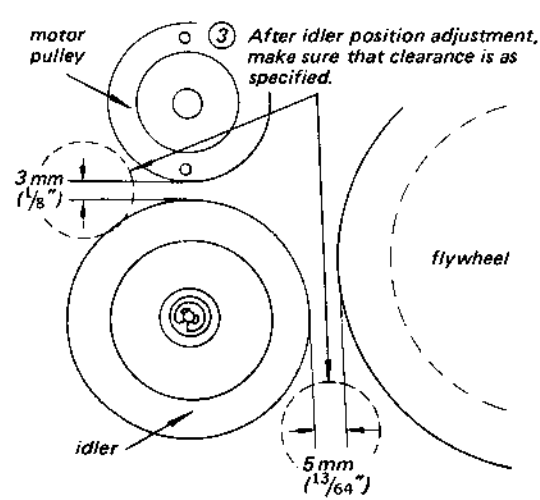

Pinch Roller Pressure Adjustment

— In Playback Mode —

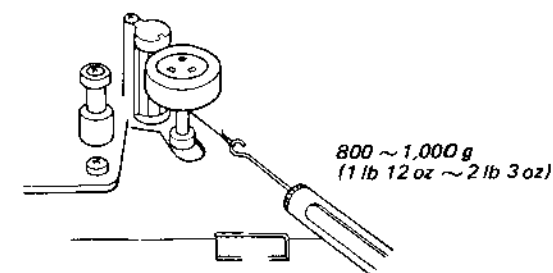

Note: The pressure should be measured just when the pinch roller contacts the capstan after being separated.

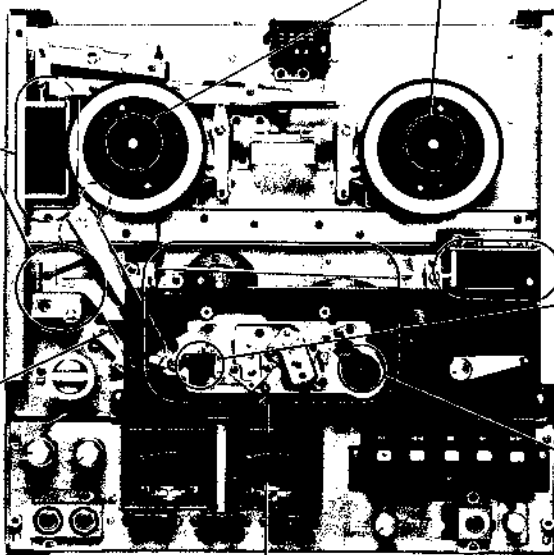

Shut-off Switch Position Adjustment

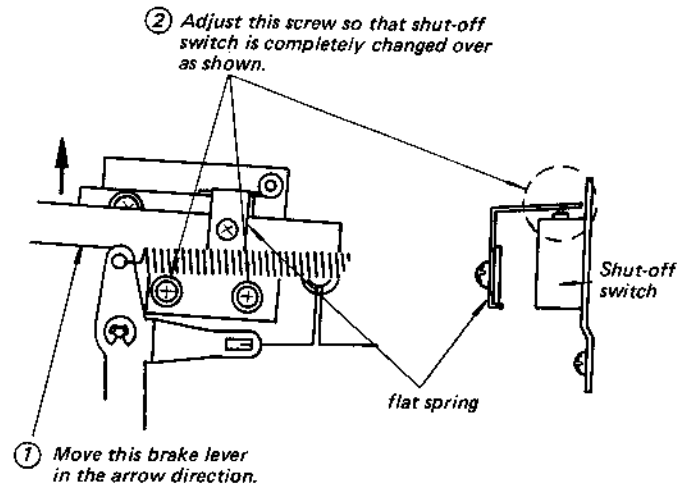

**Shut-off Mechanism Adjustment
- In Playback Mode -**

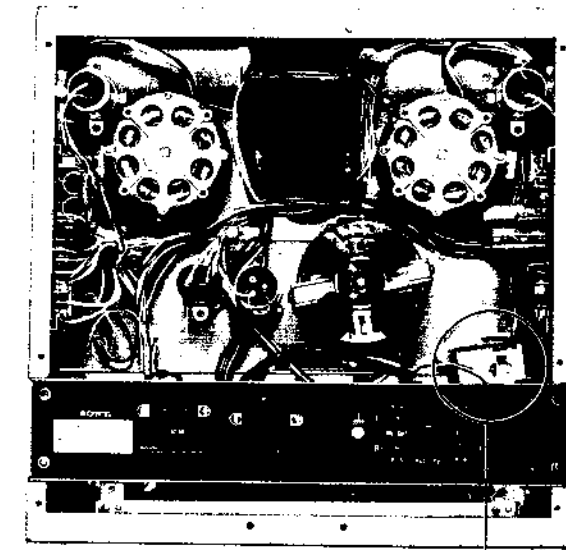
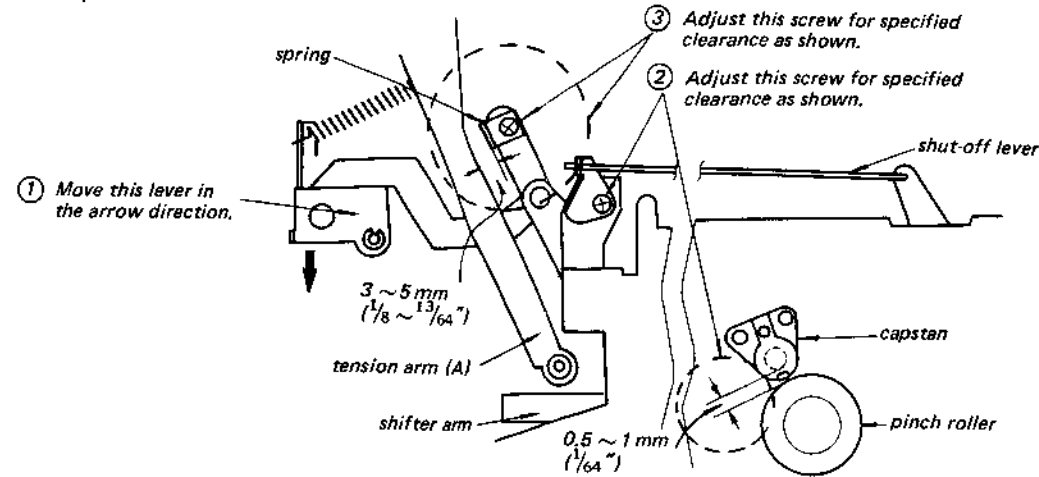

**Brake Adjustment
- In Stop Mode -**

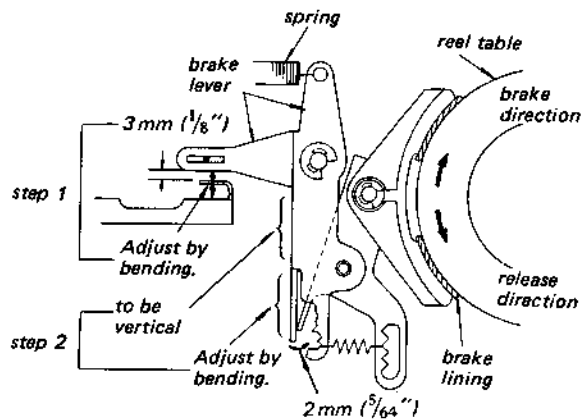

Note: 1. Adjust as specified when turning reel table in release direction.
2. When turning reel table one turn in release direction, brake lever lower tip (adjusting portion) movement should be within 2 mm ($\frac{5}{64}$ ”). If the movement is more than 2 mm ($\frac{5}{64}$ ”), reel table or brake lining is defective.

**Capstan Idler Position Adjustment
- In Stop Mode -**

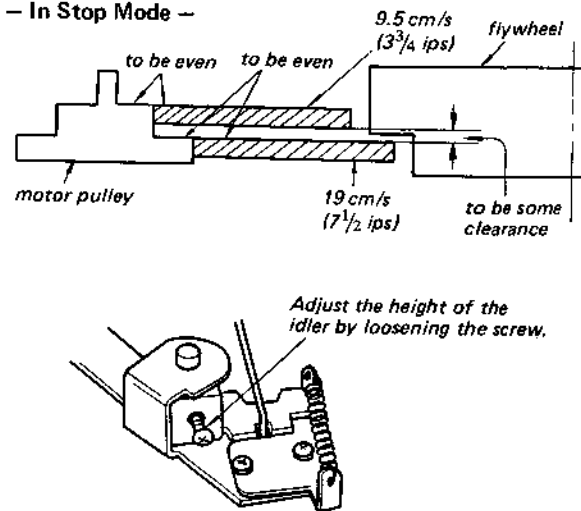

**Shut-off Mechanism Check
- In Playback Mode -**

When moving tension arm in the arrow direction as shown, make sure that take-up reel table rotates.

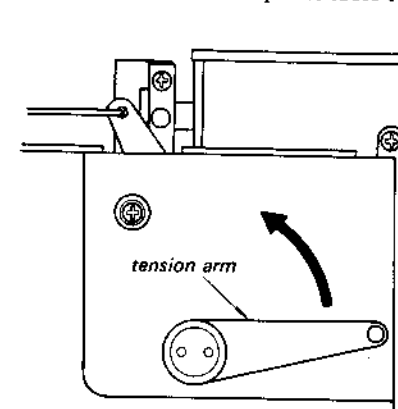

**Speed Selector Cam Position Adjustment
- In Playback Mode -**

Loosen the adjusting screw and adjust to locate the idler arm pin in the stopper slot as shown, at 19 cm/s tape speed.

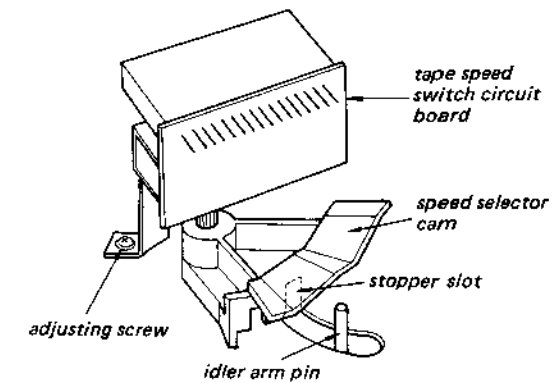

3-2. ELECTRICAL ADJUSTMENTS/
MEASUREMENTS

PRECAUTION

- Clean the following parts with an alcohol moistened swab:

record head	pinch roller
playback head	rubber belts
erase head	idlers
capstan	tape guides
- Demagnetize record head and playback head with a head demagnetizer.
- Do not use magnetized screwdriver for adjustments.
- After adjustments, apply locking paint to the adjusted parts.
- Adjustments should be performed in the order given in this service manual.
- Adjustments and measurements should be performed for both L-CH and R-CH with rated power supply voltage unless otherwise specified.
- Unless otherwise noted, set the controls as follows:

TAPE SELECT (BIAS) switch:	LOW
TAPE SELECT (EQ) switch:	NORMAL
LINE OUT controls:	MAX
TAPE SPEED selector:	7½ ips (19 cm/s)
MONITOR switch:	TAPE

Normal REC LEVEL (MIC) Control Setting:

Settings:

REC LEVEL (LINE) control: MIN
MONITOR switch: SOURCE

Procedure:

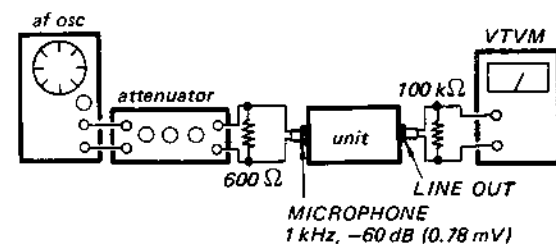

Adjust REC LEVEL (MIC) control for 0 dB (0.775 V) reading on the VTVM.

Normal REC LEVEL (LINE) Control Setting:

Settings:

REC LEVEL (MIC) control: MIN
MONITOR switch: SOURCE

Procedure:

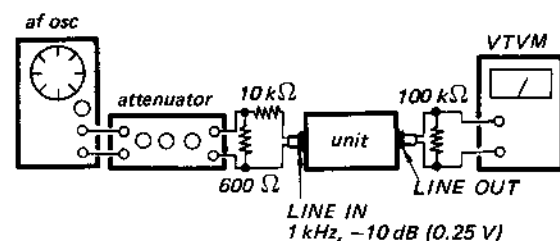

Adjust REC LEVEL (LINE) control for 0 dB (0.775 V) reading on the VTVM.

Note on Replacing the Head:

- Erase Head Removal**
When removing the erase head from the head deck, remove the two screws shown with ▲.
(Do not remove the three screws shown below *.)
- Record or Playback Head Removal**
When removing the record or the p.b. head, remove the respective angle adjusting screws.
(Do not turn the screws except the angle adjusting screws.)

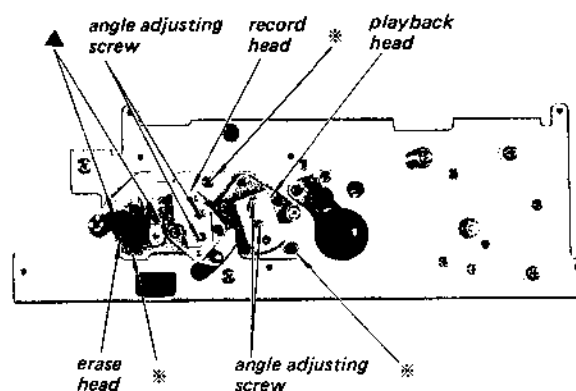

1. Tape Path Adjustment

A. Tape Guide (left) Adjustment

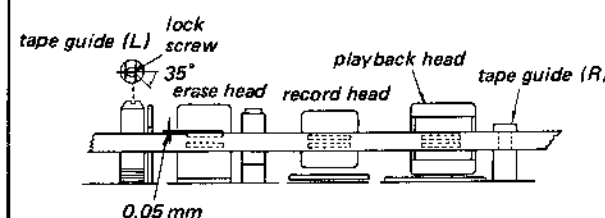

Procedure:

- Thread a tape and place unit in playback mode.
- Loosen the lock screw and align the upper edge of the erase head core and that of the tape by turning tape guide (L).
- Turn tape guide (L) clockwise by approximately 35 degrees from the position obtained in the preceding step so that the upper edge of the tape is approximately 0.05 mm (2 mil) lower than the upper edge of the erase head core.
- Fix the tape guide with the lock screw.

B. Record and Playback Head Preadjustment

(Rough adjustment for Playback Head Angle Adjustment and Playback Head Azimuth Adjustment)

Note: This adjustment and the following adjustments (Playback Head Angle Adjustment and Playback Head Azimuth Adjustment) should be repeated alternately several times.

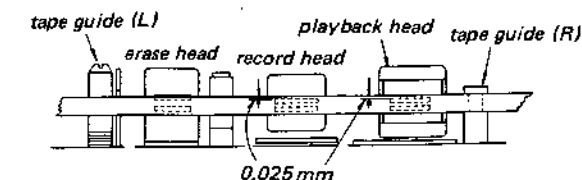

Procedure:

- Align the upper edges of record and playback head cores and that of the tape by evenly turning the record and playback head height adjusting screws.
- Turn record and playback head height adjusting screws clockwise by approximately 15 degrees so that the upper edges of record and playback head cores are 0.025 mm (1 mil) lower than that of the tape and memorize the angle of turns.
- Turn zenith adjusting screws by the same angle of turns to the same direction of record and playback head height adjusting screws.
- Thread SONY tape super 150 or PS-2 and place unit in playback mode at 19 cm/s (7½ ips).
- Make the tape loose a little by pushing the tension regulator arm pin in the direction shown by arrow and then adjust playback head and record head zenith adjusting screws to obtain the reflection of light as shown.

Adjustment Location:

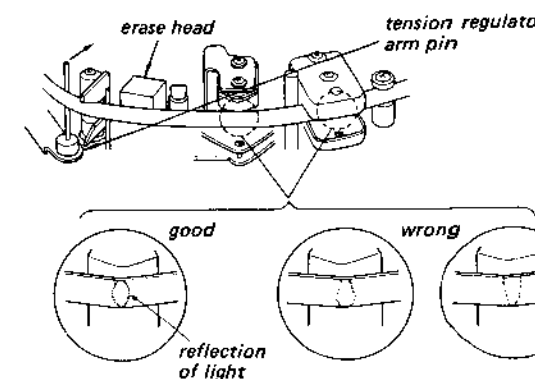
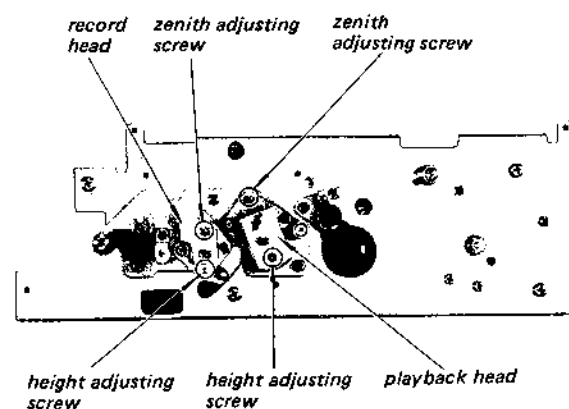

2. Tape Curl Adjustment

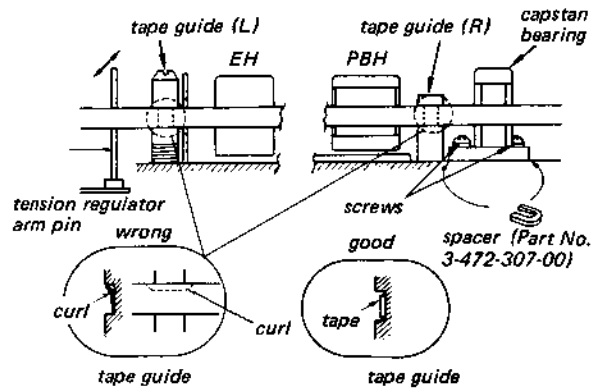

Procedure:

1. Thread SONY tape super 200 (thin tape) and place unit in playback mode at 19 cm/s (7½ ips) tape speed.
2. Be sure that the tape comes in contact with two tape guides exactly as shown.
 - a) If tape is curled at tape guide (L), adjust by bending tension regulator arm pin with fingers.
 - b) If tape is curled at tape guide (R), loosen two capstan bearing holding screws and adjust by adding or removing the spacer.

Note: After adding or removing the spacer (0.1 mm thick), perform playback head zenith adjusting screw. (See "Record and Playback Head Preadjustment" on page 12.)

3. Playback Head Angle Adjustment

Procedure:

1. Mode: playback
J-19-F1 (1st tone 10 kHz)

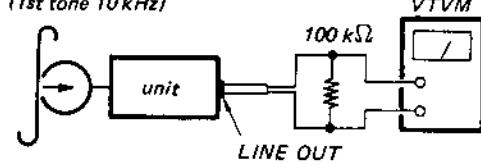

Adjust angle-adjusting screws for maximum VTVM reading.

2. Apply back-tension by holding lightly the supply reel table, reproducing the alignment tape, and then adjust the angle of the head by loosening two angle-adjusting screws so that VTVM reading on both L-CH and R-CH does not rise.

Note: Unless playback head is installed at correct angle, VTVM reading will rise.

Adjustment Location:

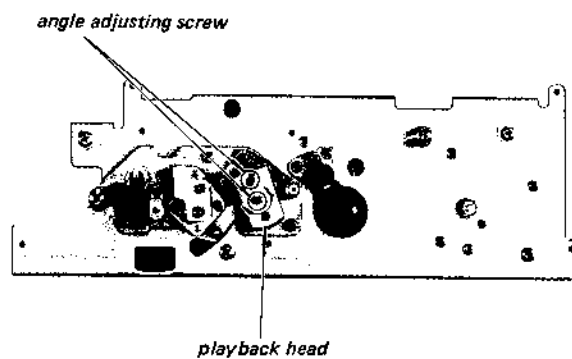

4. Playback Head Azimuth Adjustment

Procedure:

1. Be sure that playback head is fixed sufficiently to head deck with holding screw as shown below and tape path adjustment has been made.
2. Mode: playback
J-19-F1 (1st tone 10 kHz)

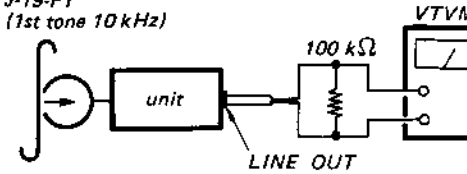

Adjust azimuth adjusting screw for maximum VTVM reading.

Note: If azimuth angles of L-CH and R-CH are not the same, set the screw midway between two screw positions.

Adjustment Location:

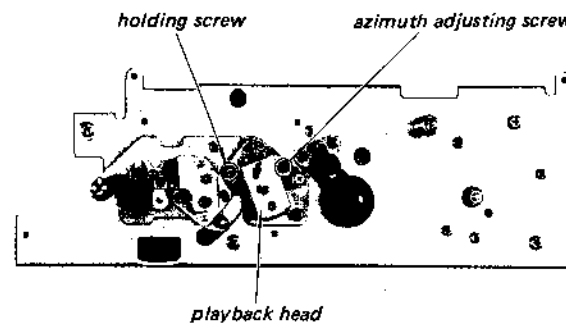

5. Playback Head Phase Check

Procedure:

1. Mode: playback

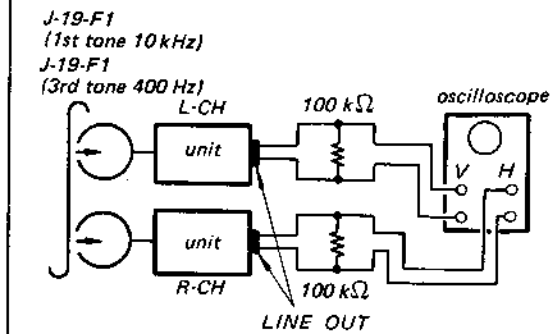

Adjust	On the oscilloscope			
azimuth adjusting screw				
(400 Hz)	good	wrong		
(10 kHz)	good		wrong	

Note: If necessary, finely adjust the playback head azimuth adjusting screw.

Adjustment Location:

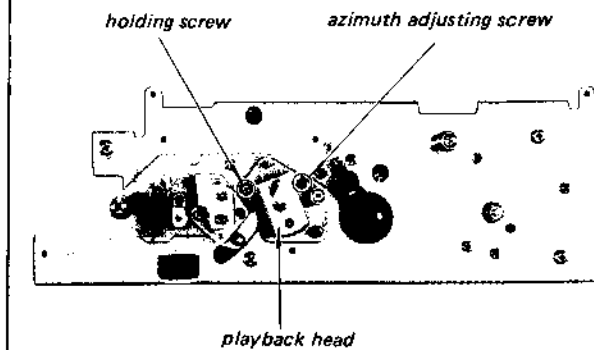

6. Playback Output Level Adjustment and Level Meter Calibration

Procedure:

1. Mode: playback

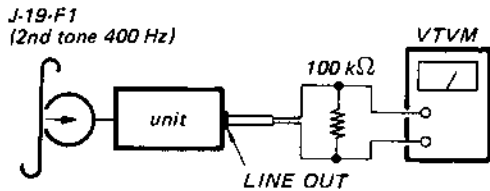

Adjust R315, R415 for 0 dB (0.775 V) VTVM reading.

2. Adjust R327, R427 for 0 reading on RECORD LEVEL meters.
3. Change TAPE SELECT switch to SLH and be sure that VTVM reading is -2 dB ~ -3 dB (0.62 ~ 0.55 V).

Adjustment Location:

[Audio Amp Circuit Board]

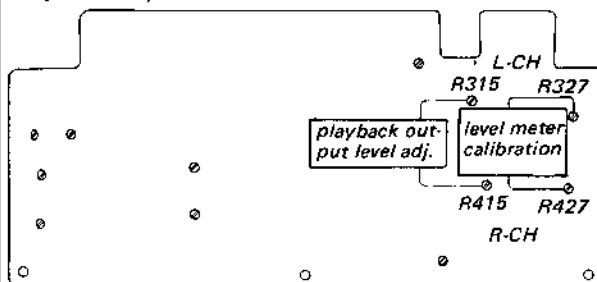

7. Playback Equalizer Adjustment

Procedure:

1. Mode: playback

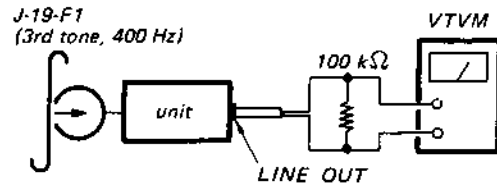

Memorize VTVM reading.

2. Mode: playback

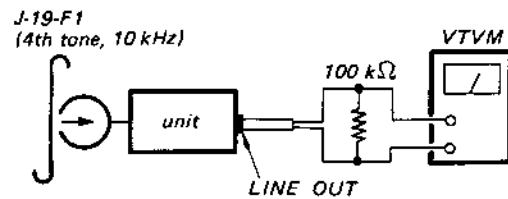

Adjust R313, 413 to obtain the same VTVM reading as in step 1.

3. Playback the following tones and make sure that each tone output level deviation relative to 3rd tone is as follows.

Tone	4th	5th	6th	7th
Frequency (Hz)	10 k	7 k	80	40
Level Deviation from 3rd tone (400 Hz)	0 ± 1 dB	0 ± 2 dB	2 ± 2 dB	2 ± 2 dB

Adjustment Location:

[Audio Amp Circuit Board]

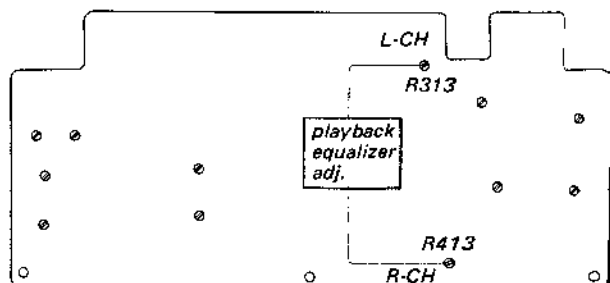

8. Playback Signal-to-Noise Ratio Check

Procedure:

1. Mode: playback

J-19-F1
(2nd tone, 400 Hz)

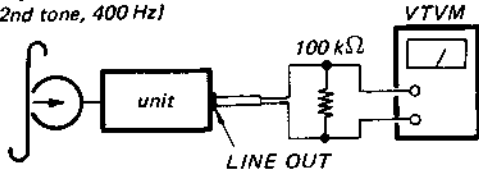

Be sure that VTVM reading is 0 dB (0.775 V). If not, make playback output level adjustment again.

2. Mode: playback

Note: With no tape threaded, keep on pushing shut-off lever with finger.

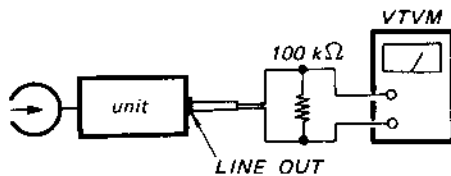

Be sure that VTVM reading is less than -48 dB (3 mV).

Note: S/N ratio may change by reversing the sense of motor leads.

9. Record Head Azimuth Adjustment

Settings:

REC LEVEL (LINE) control: normal position on page 11.

Procedure:

1. Mode: record

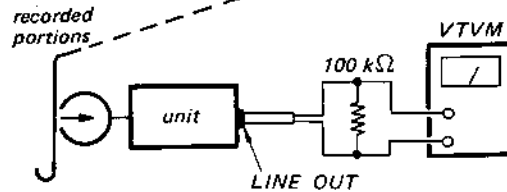
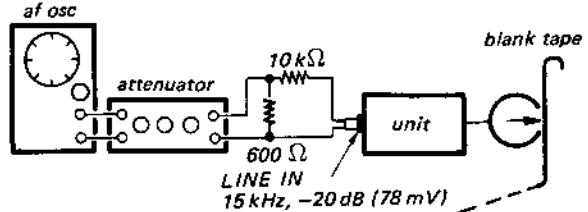

Adjust azimuth adjusting screw for maximum VTVM reading.

Note: If the maximum value of L-CH and R-CH outputs can not be obtained at the same angle, adjust the screw midway between two screw positions. (That value should not be fallen more than 1 dB from the maximum value.)

Adjustment Location:

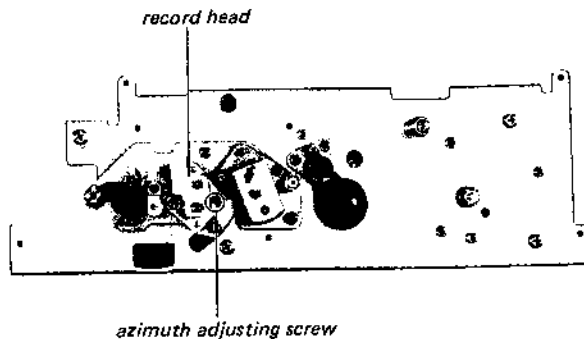

10. Record Head Track Position Adjustment

Settings:

REC LEVEL (LINE) control: normal position on page 11.

Procedure:

1. Mode: record

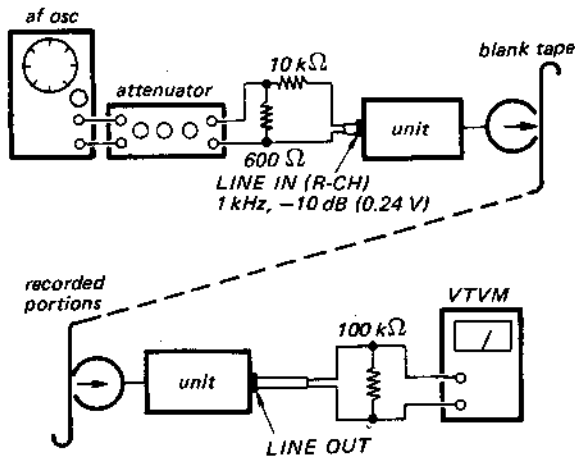

Adjust the height adjusting screw for maximum VTVM reading and memorize the angle of turns of the screw.

2. Turn the zenith adjusting screw by the same angle of turns obtained in preceding step 1.
3. After the adjustment, check tape path adjustment on page 12 again.

Adjustment Location:

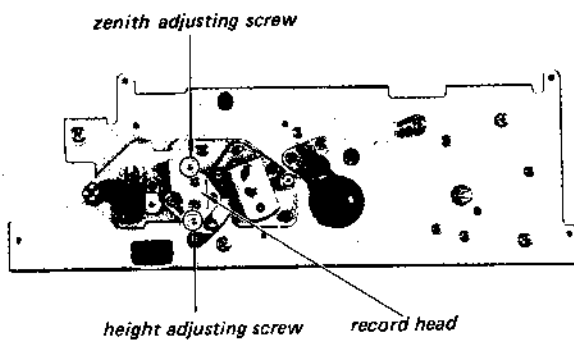

11. Record Head Phase Check

Settings:

REC LEVEL (LINE) control: normal position on page 11.

Procedure:

1. Make the playback head phase check on page 14.
2. Mode: record

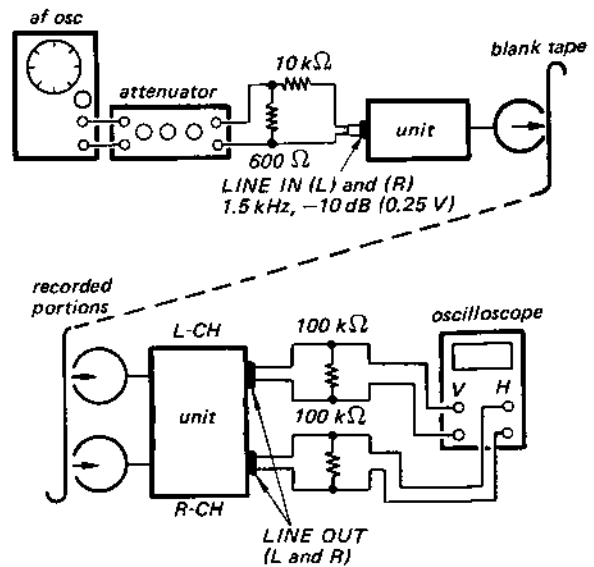

Adjust	On the oscilloscope			
azimuth adjusting screw				
	in-phase	within 30°	more than 30°	more than 90°
	good		wrong	

Note: If necessary, finely adjust record head azimuth adjusting screw.

Adjustment Location:

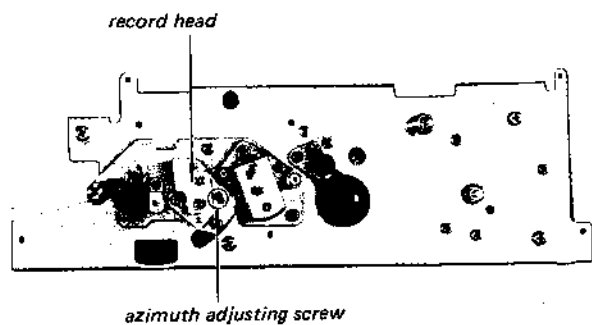

12. Trap Coil Adjustment

Settings:

REC LEVEL (MIC) control: MIN

Procedure:

1. Mode: record

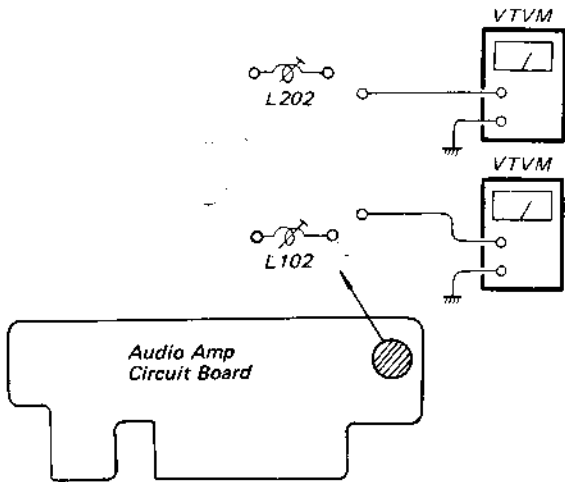

Adjust L102, L202 for minimum reading on the VTVM.

Adjustment Location:

[Audio Amp Circuit Board]

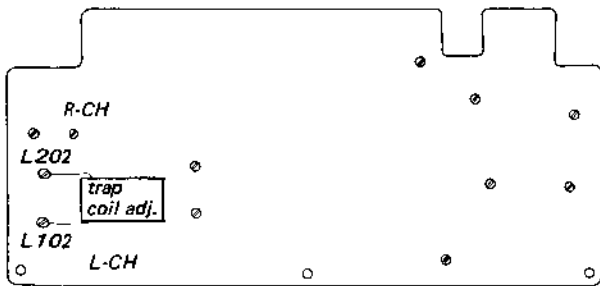

13. Record Bias Adjustment

Settings:

REC LEVEL (LINE) control: normal position on page 11.

REC LEVEL (MIC) control: MIN

Procedure:

1. Be sure that trap coil adjustment has been made.
2. Mode: record

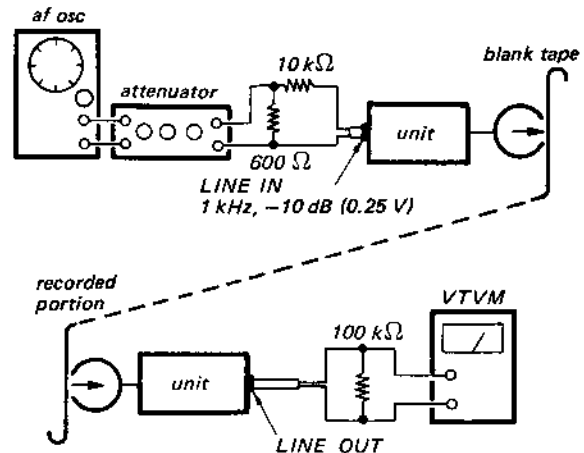

Adjust	Remarks
trimmer capacitor C127, C227	Slowly turn the trimmer capacitor clockwise until VTVM reads 0.5 dB below and beyond the maximum reading as shown.

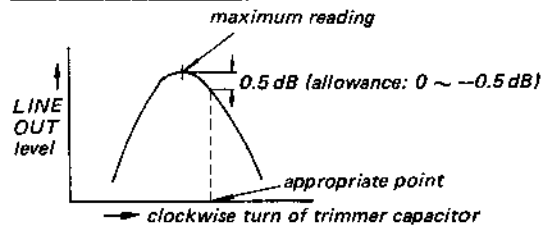

Adjustment Location:

[Audio Amp Circuit Board]

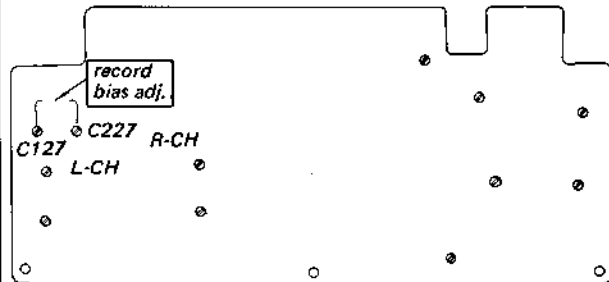

14. Record Level Adjustment

Settings:

TAPE SELECT switch: NORMAL
 REC LEVEL (LINE) control: normal position on page 11.

Procedure:

1. Mode: record

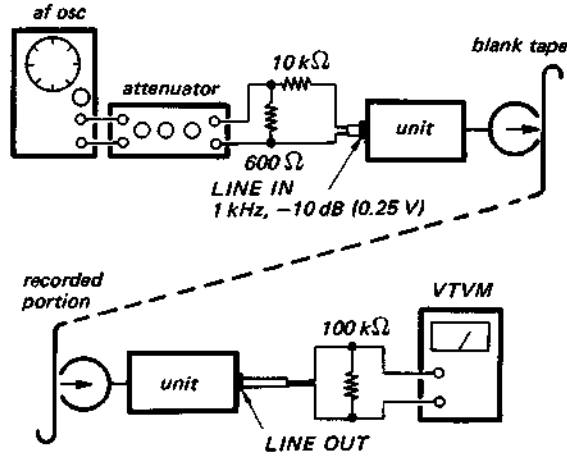

Adjust R116, R216 for 0 dB (0.775 V) reading on the VTVM.

2. Be sure that VTVM reading is 0 dB (0.775 V) when changing MONITOR switch from TAPE to SOURCE position and the pointer of RECORD LEVEL meter stays at "0".
3. When TAPE SELECT switch is changed to SPECIAL with MONITOR switch to SOURCE, VTVM reading should decrease approx. 1.5 dB.

Adjustment Location:

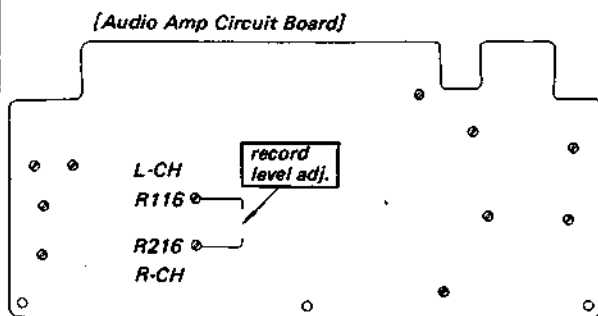

15. Dummy Coil Adjustment

Settings:

REC LEVEL (LINE) control: normal position on page 11.

Procedure:

1. Mode: stereo record

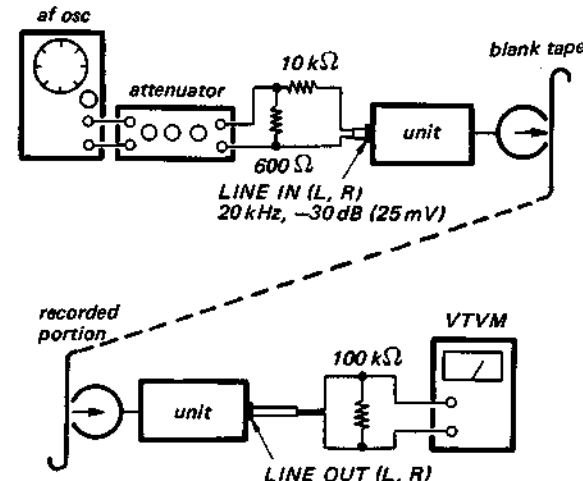

Memorize VTVM reading.

2. Set L-channel (R-channel) only in record mode.
3. Adjust L103 (L203) with non-magnetic screwdriver, taking care not to break the core, so that VTVM reading is the same as that obtained in step 1.

Adjustment Location:

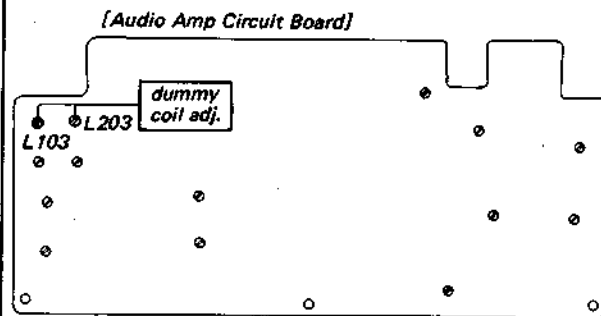

16. Overall Frequency Response Measurement

Settings:

REC LEVEL (LINE) control: normal position on page 11.
 TAPE SELECT switch: NORMAL and SPECIAL
 TAPE SPEED selector: 19 cm/s (7½ ips)
 9.5 cm/s (3¾ ips)

Procedure:

1. Mode: record

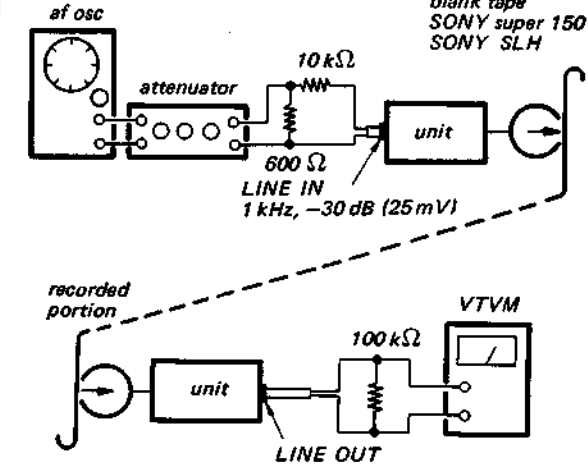

Memorize VTVM reading.

2. Level Deviation from 1 kHz signal. (for both SPECIAL and NORMAL)

Frequency	50 Hz	100 Hz	5 kHz	7 kHz	12.5 kHz	20 kHz
19 cm/s	± 3 dB	± 3	± 3	± 3	± 3	+3 -4
9.5 cm/s	+3 -6	± 3	± 3	± 3	+3 -4	

Note: When recording signal on SONY tape "super 150", set TAPE SELECT switch to NORMAL and on SONY SLH tape, to SPECIAL.

SECTION 4
DIAGRAMS

16. Overall Frequency Response Measurement

Settings:

- REC LEVEL (LINE) control: normal position on page 11.
- TAPE SELECT switch: NORMAL and SPECIAL
- TAPE SPEED selector: 19 cm/s (7½ ips)
9.5 cm/s (3¾ ips)

Procedure:

1. Mode: record

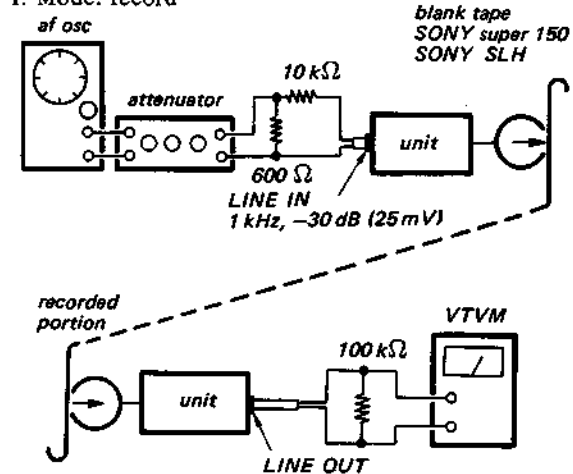

Memorize VTVM reading.

2. Level Deviation from 1 kHz signal. (for both SPECIAL and NORMAL)

Frequency	50 Hz	100 Hz	5 kHz	7 kHz	12.5 kHz	20 kHz
Tape speed						
19 cm/s	±3 dB	±3	±3	±3	±3	±3/4
9.5 cm/s	+3/-6	±3	±3	±3	+3/-4	

Note: When recording signal on SONY tape "super 150", set TAPE SELECT switch to NORMAL and on SONY SLH tape, to SPECIAL.

4-1. LEVEL DIAGRAMMS

- Record Mode -

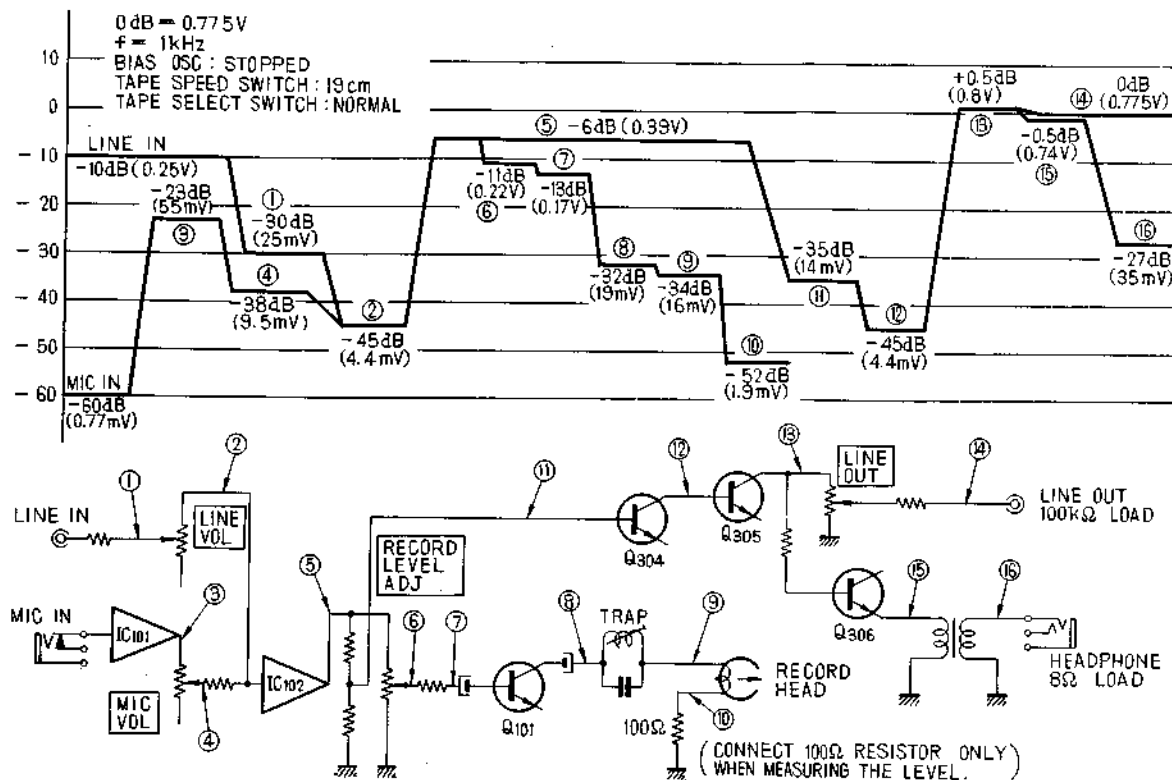

- Playback Mode -

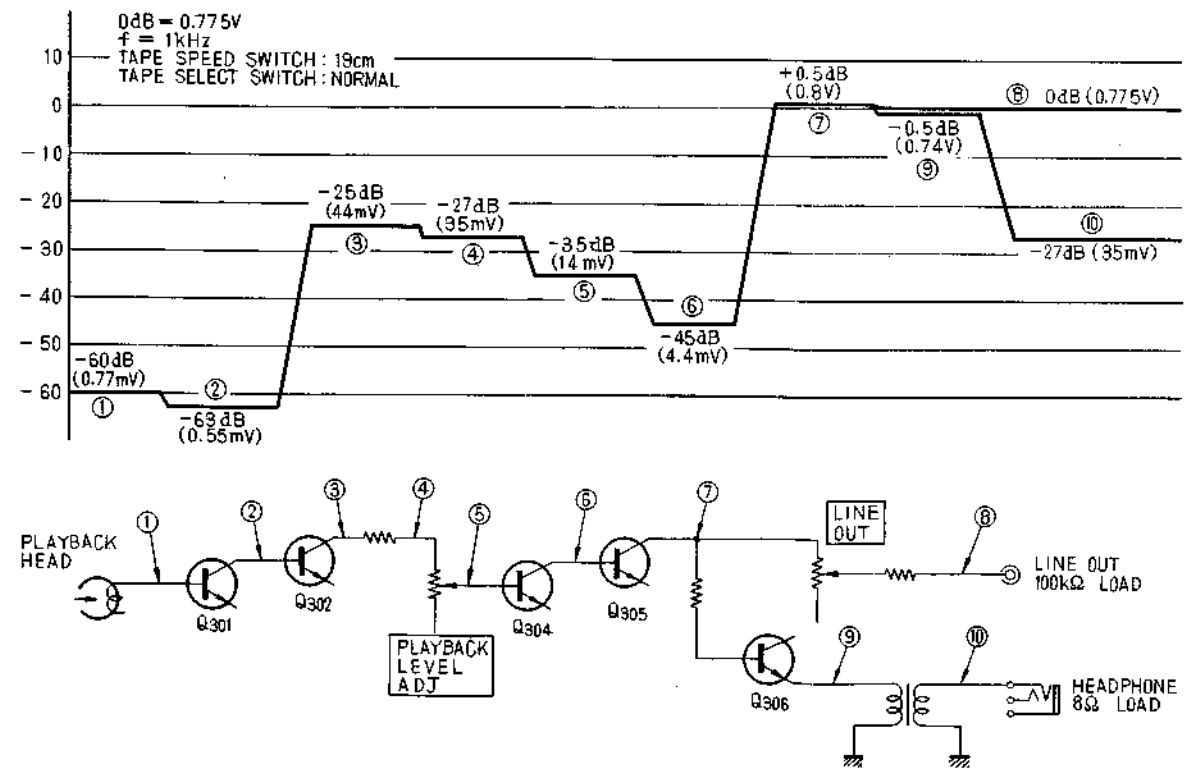

4-2. MOUNTING DIAGRAMS
- Conductor Side -

Q101, Q201 }
Q303 ~ Q306 } 2SC1364
Q403 ~ Q406 }
Q602, Q603 }

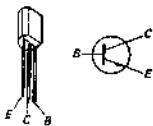

Q301, Q401 } 2SC1362
Q302, Q402 }

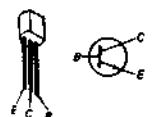

Q601: 2SD291

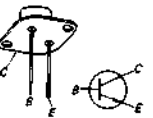

IC101, IC201 } TA7122AP
IC102, IC202 }

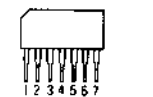

D301, D401: 1T22A
D711: RD-15E

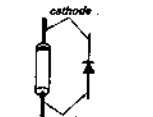

D601 ~ D604 } S1B01-02
D701 ~ D710 }

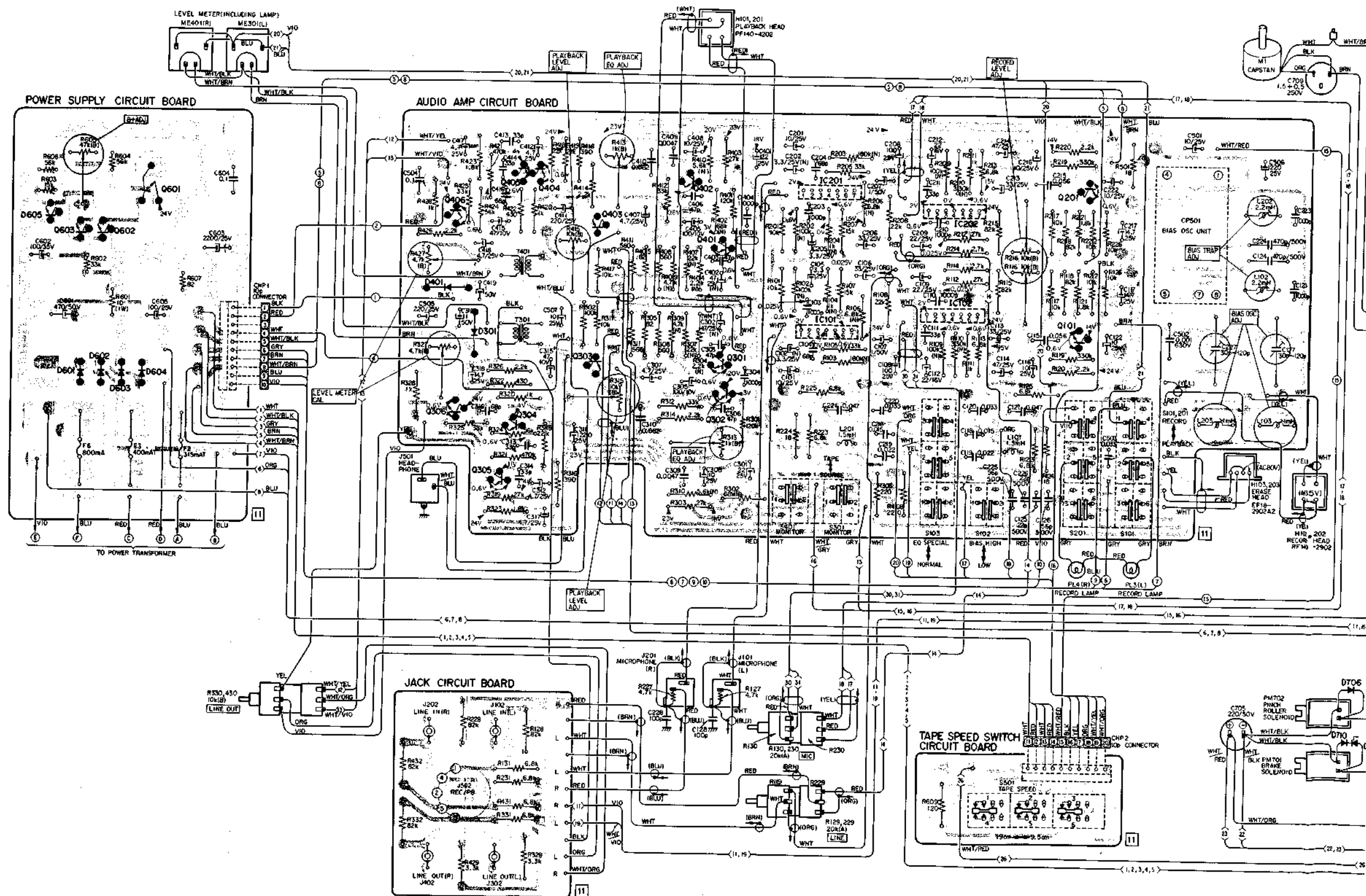
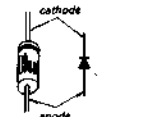

Q, IC	Q603, Q602, Q601	Q406, Q306, Q305, Q304	Q405, Q403	Q402, Q401, Q302	IC201, IC101	IC202, IC102	Q201, Q101
0	D605, D601, D602, D603, D604	D401, Q301					

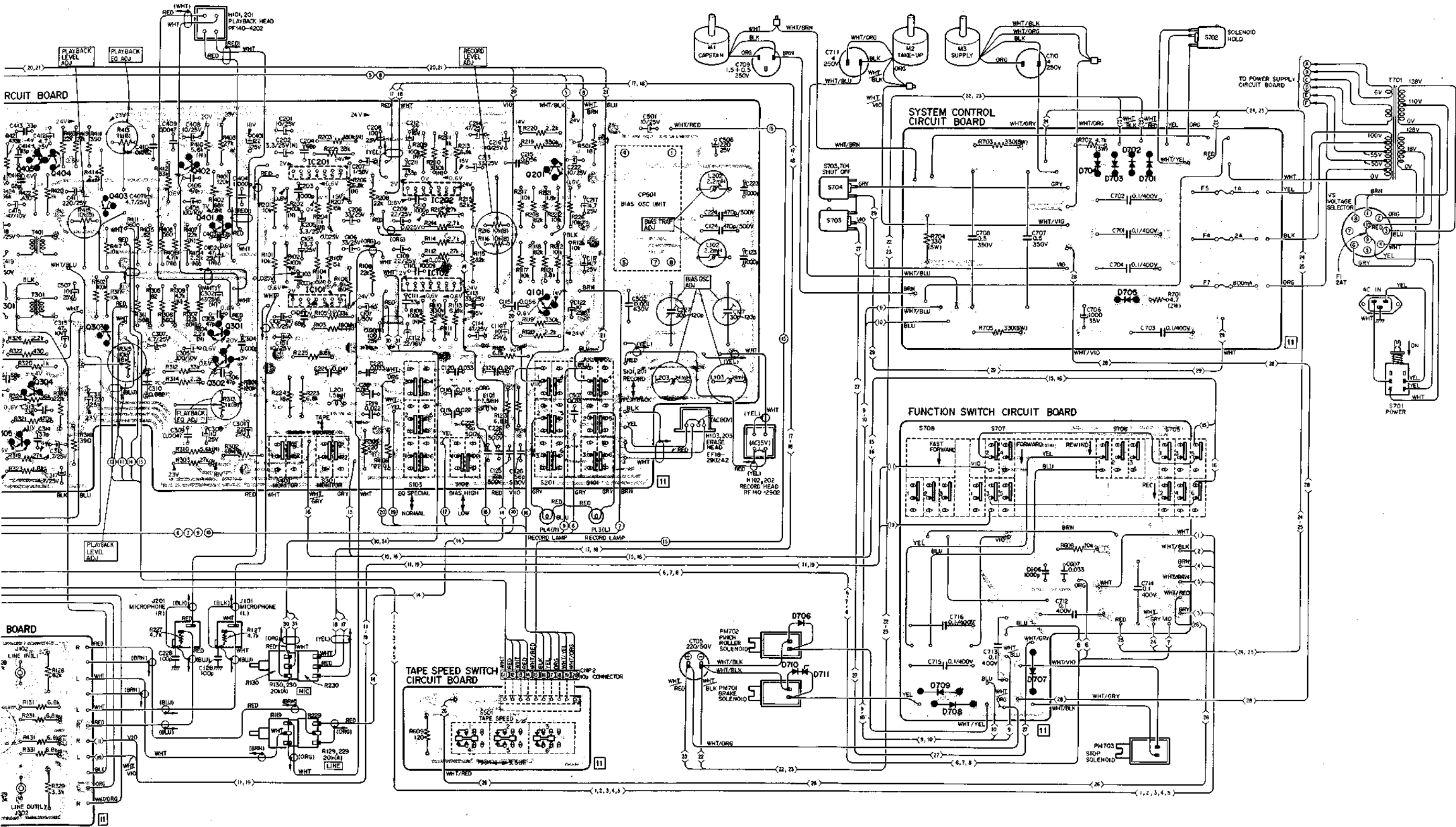

Q405	Q404	Q403	Q402	Q401	IC201	IC202	Q201	D706	D709	D707	D704, D703, D702, D701
Q305	Q304	Q303		Q302	IC101	IC102	Q101	D710, D711	D708		D705

4.3. SCHEMATIC DIAGRAM

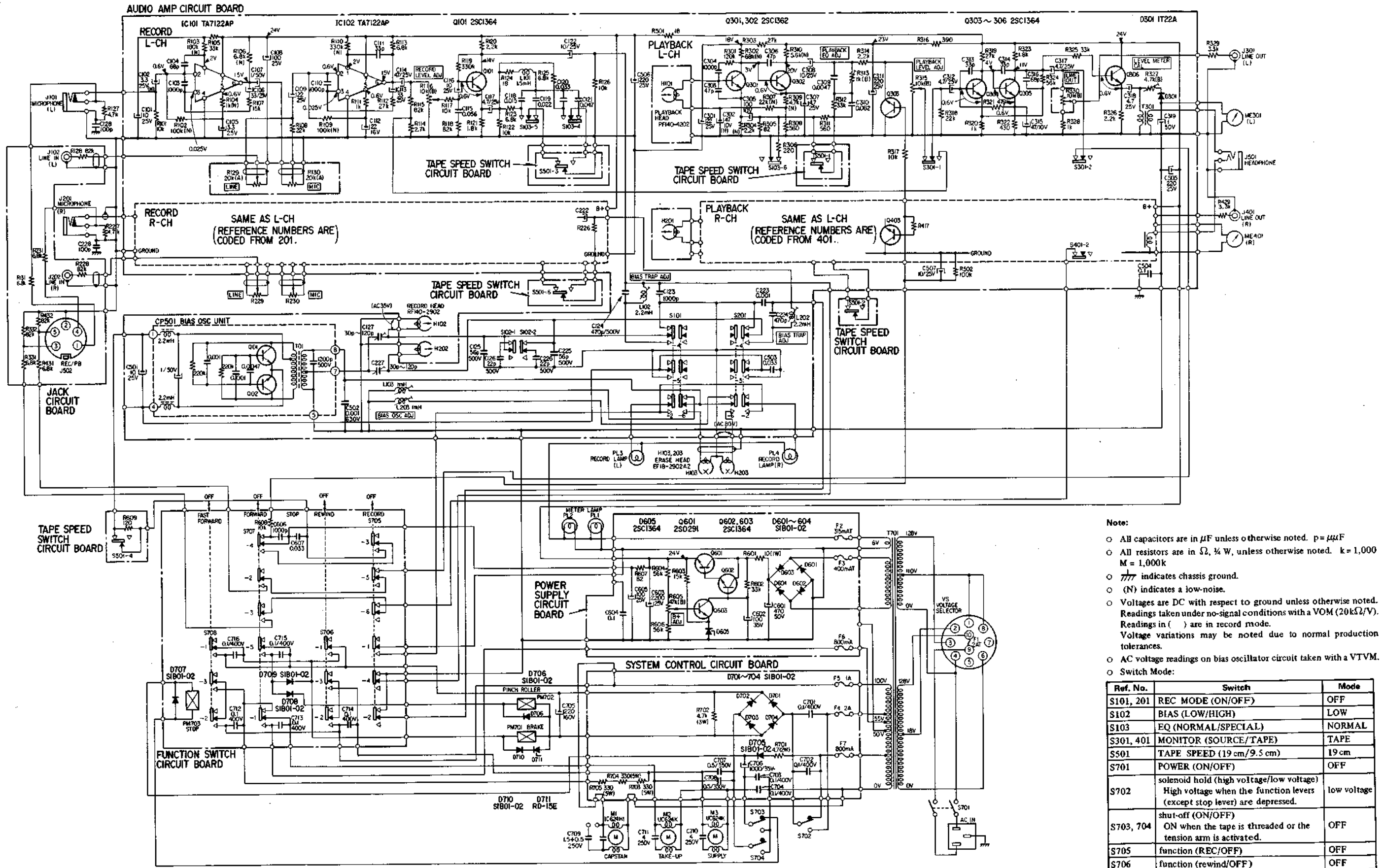

Note:

- All capacitors are in μF unless otherwise noted. $p = \mu\mu\text{F}$
- All resistors are in Ω , $\frac{1}{2} W$, unless otherwise noted. $k = 1,000$
 $M = 1,000k$
- --- indicates chassis ground.
- (N) indicates a low-noise.
- Voltages are DC with respect to ground unless otherwise noted. Readings taken under no-signal conditions with a VOM (20k Ω/V). Readings in () are in record mode. Voltage variations may be noted due to normal production tolerances.
- AC voltage readings on bias oscillator circuit taken with a VTVM.
- Switch Mode:

Ref. No.	Switch	Mode
S101, 201	REC MODE (ON/OFF)	OFF
S102	BIAS (LOW/HIGH)	LOW
S103	EQ (NORMAL/SPECIAL)	NORMAL
S301, 401	MONITOR (SOURCE/TAPE)	TAPE
S501	TAPE SPEED (19 cm/9.5 cm)	19 cm
S701	POWER (ON/OFF)	OFF
S702	solenoid hold (high voltage/low voltage) High voltage when the function levers (except stop lever) are depressed.	low voltage
S703, 704	shut-off (ON/OFF) ON when the tape is threaded or the tension arm is activated.	OFF
S705	function (REC/OFF)	OFF
S706	function (rewind/OFF)	OFF
S707	function (forward/OFF)	OFF
S708	function (fast forward/OFF)	OFF

SECTION 5
EXPLODED VIEWS

5-1. EXPLODED VIEW (1)

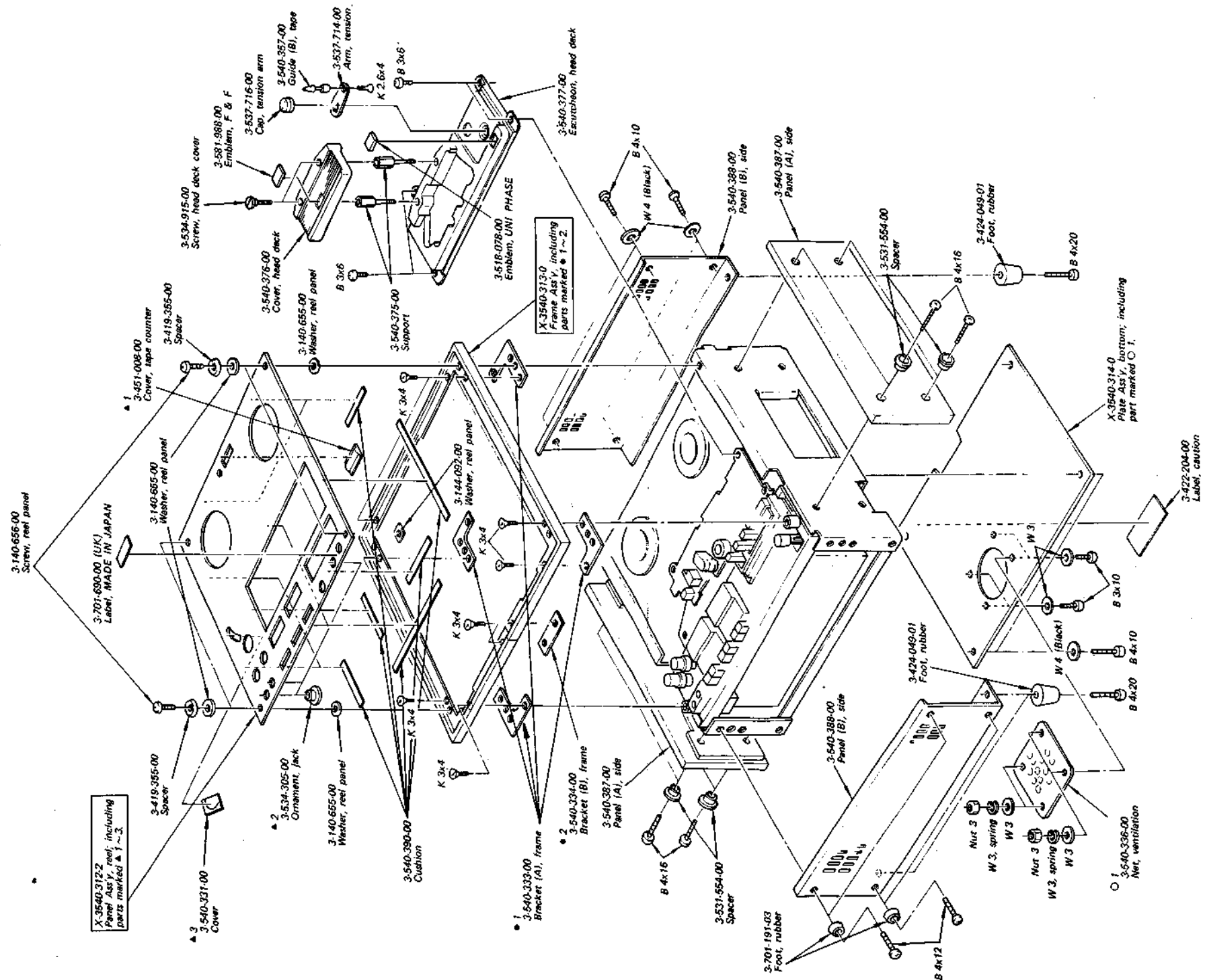

5-2. EXPLODED VIEW (2)

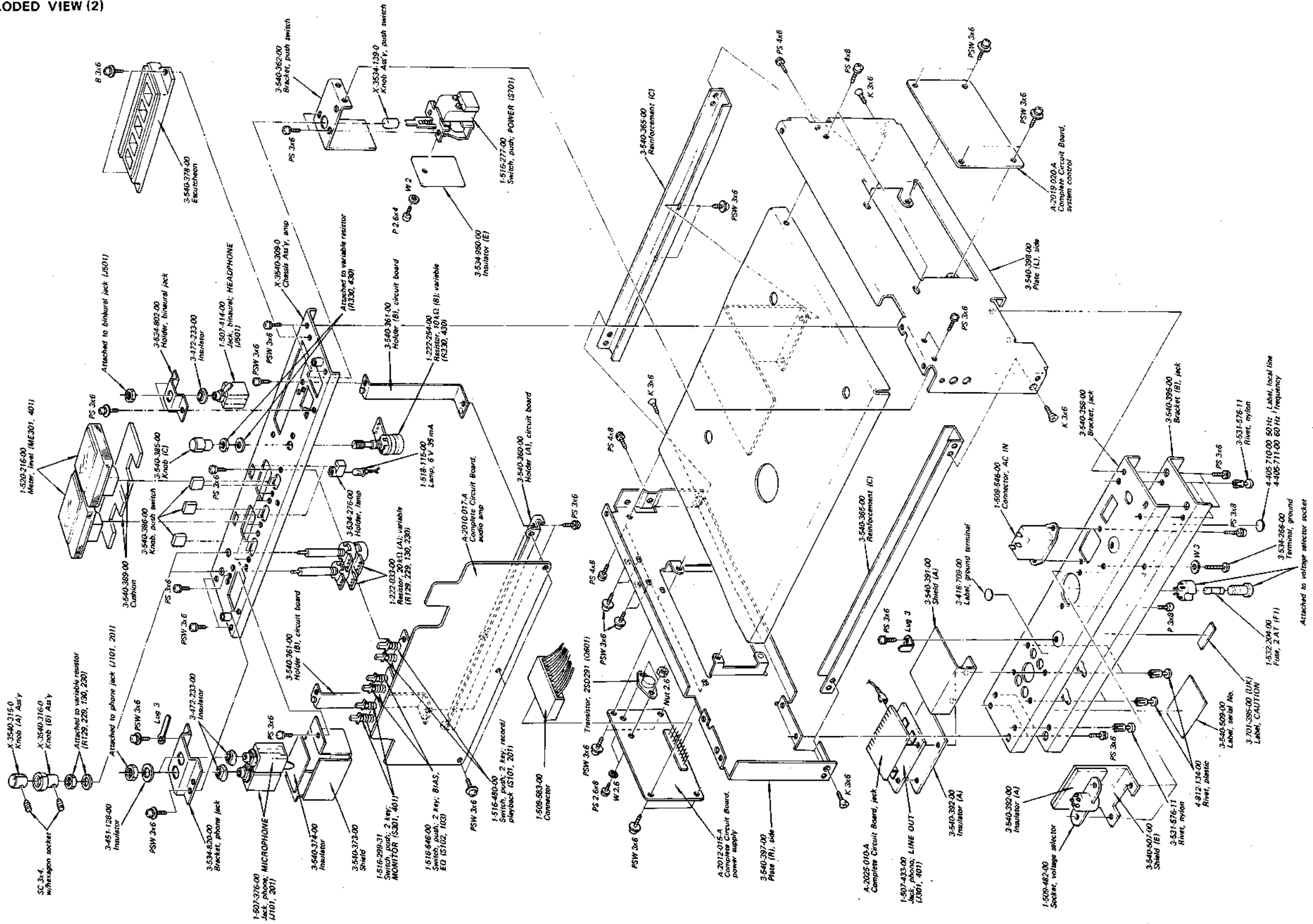

Note:

- Items without part number and description are not available.
- All screws are Phillips (cross recess) type unless otherwise noted.
- (-) = slotted head

5-3. EXPLODED VIEW (3)

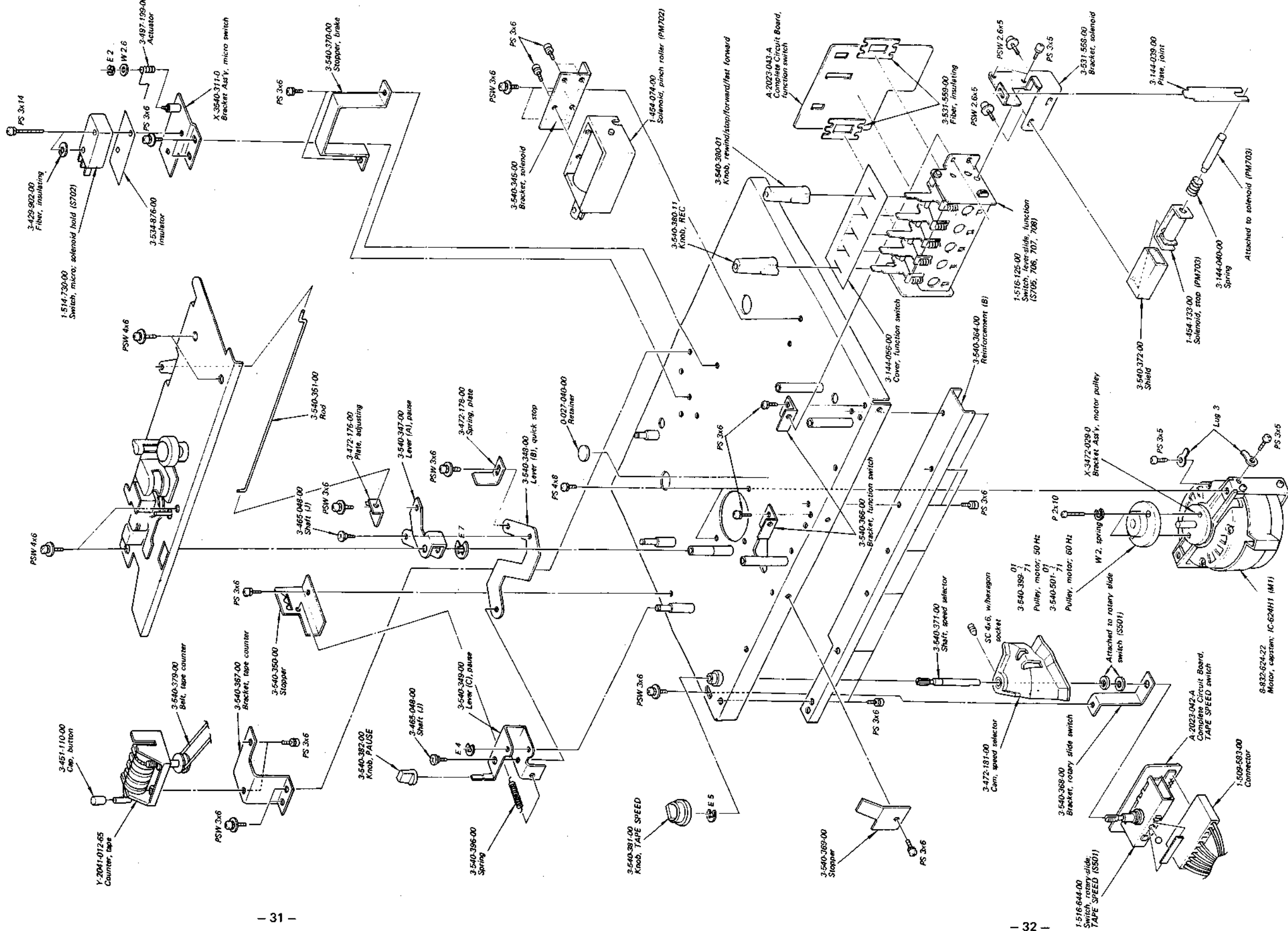

Note:

- Items without part number and description are not available.
- All screws are Phillips (cross recess) type unless otherwise noted.
- (-) = slotted head

5-4. EXPLODED VIEW (4)

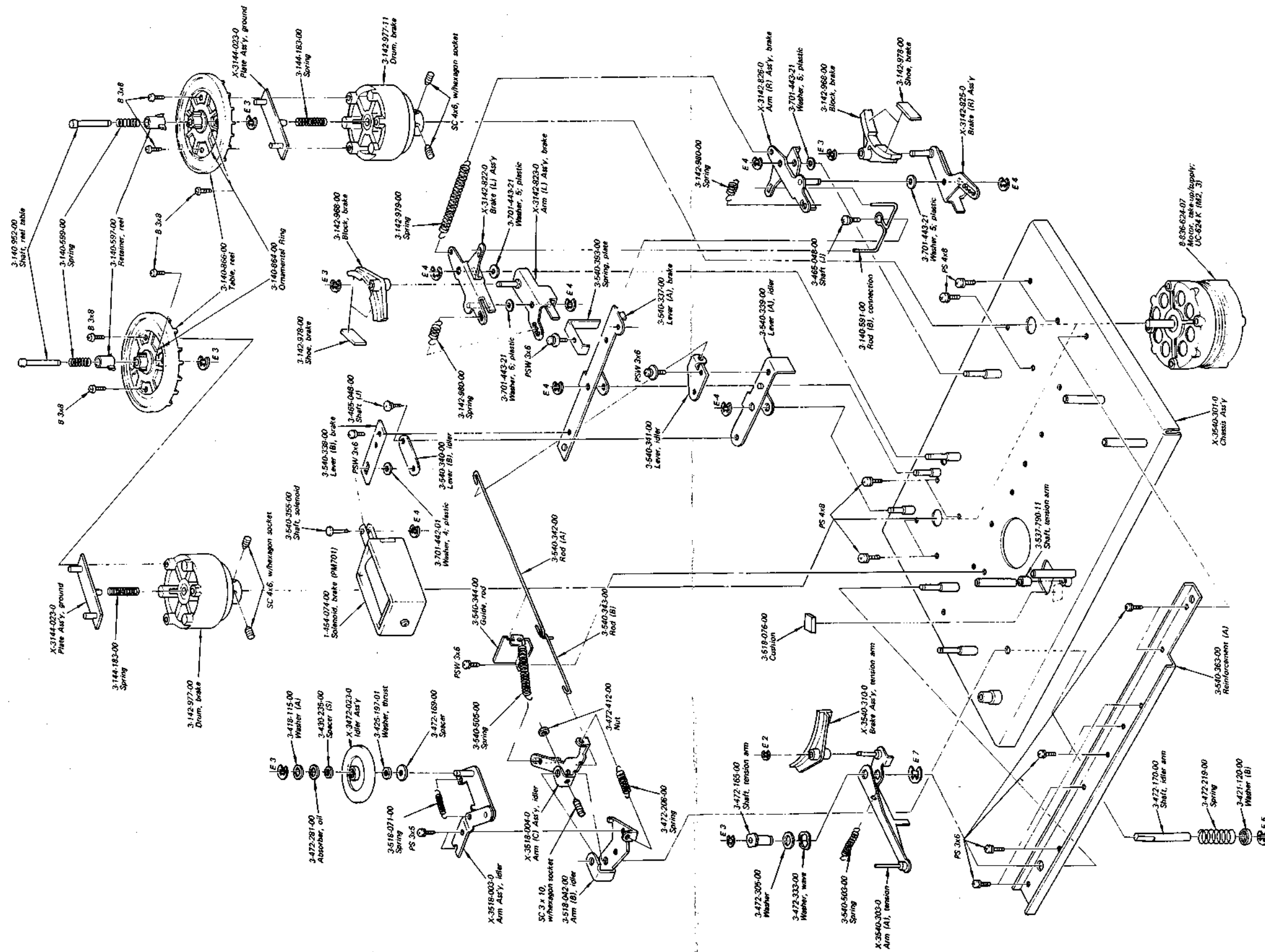

Note:

- Items without part number and description are not available.
- All screws are Phillips (cross recess) type unless otherwise noted.
- (-) = slotted head

5-5. EXPLODED VIEW (5)

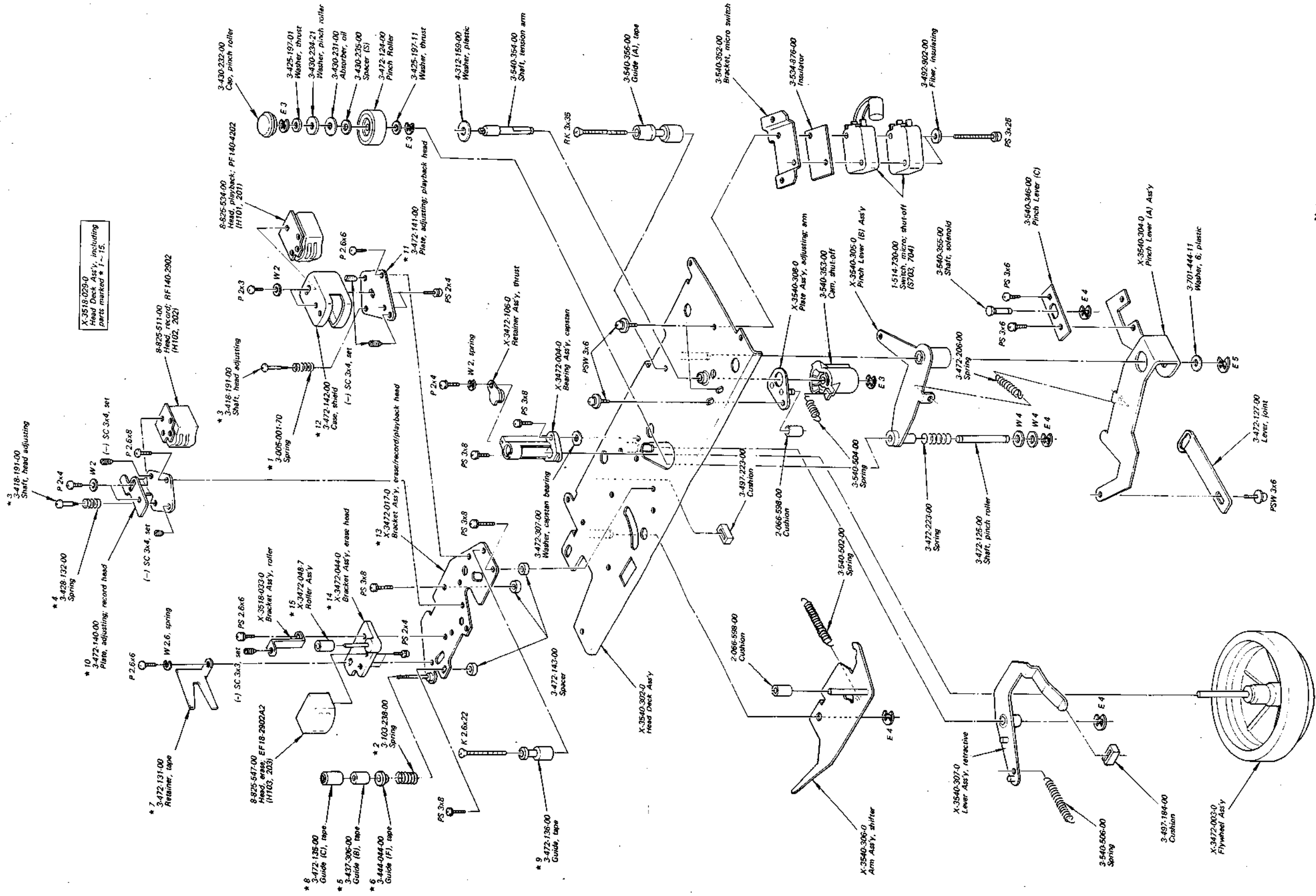

Note:

- Items without part number and description are not available.
- All screws are Phillips (cross recess) type unless otherwise noted.
- (-) = slotted head

5-6. EXPLODED VIEW (6)

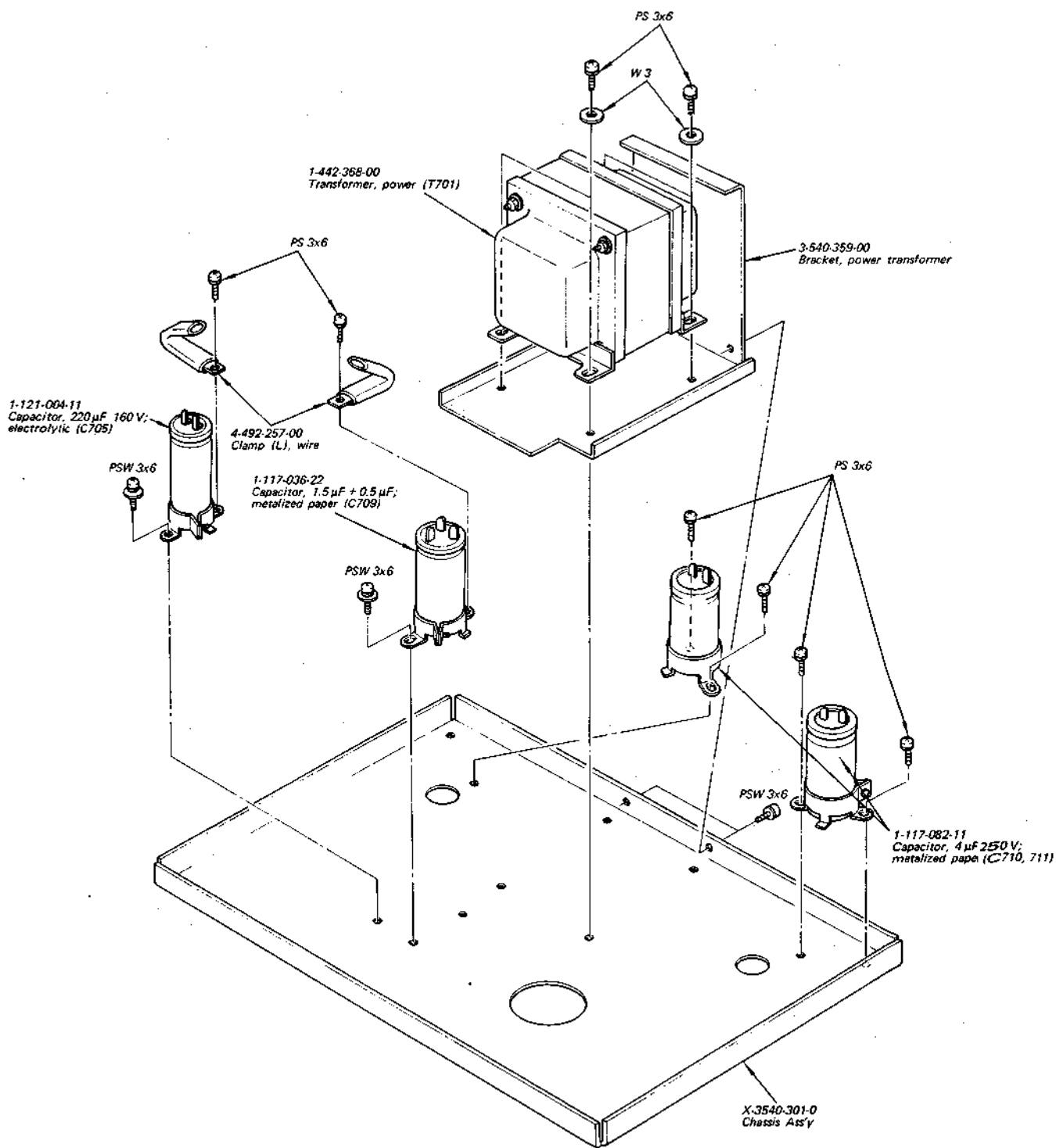

Note:

- Items without part number and description are not available.
- All screws are Phillips (cross recess) type unless otherwise noted.
- (-) = slotted head

**SECTION 6
ELECTRICAL PARTS LIST**

<u>Ref. No.</u>	<u>Part No.</u>	<u>Description</u>							<u>Ref. No.</u>	<u>Part No.</u>	<u>Description</u>						
COMPLETE CIRCUIT BOARDS																	
	A-2010-017-A	Audio Amp							C104, 204	1-101-889-51	68 p	50 V	ceramic				
	A-2012-015-A	Power Supply							C105, 205	1-121-392-51	3.3	25 V	elect				
	A-2019-020-A	System Control							C106, 206	1-121-404-51	33	25 V	elect				
	A-2023-042-A	TAPE SPEED Switch							C107, 207	1-121-391-51	1	50 V	elect				
	A-2023-043-A	Function Switch							C108, 208	1-121-416-51	100	25 V	elect				
	A-2025-010-A	Jack							C109, 209	1-121-480-51	22	25 V	elect				
									C110, 210	1-102-074-51	1000 p	50 V	ceramic				
SEMICONDUCTORS																	
Q101, 201		Transistor	2SC1364						C111, 211	1-102-969-51	33 p	50 V	ceramic				
Q301, 401		Transistor	2SC1362						C112, 212	1-121-479-51	22	16 V	elect				
Q302, 402										C113, 213	1-121-404-51	33	25 V	elect			
Q303 ~ 306		Transistor	2SC1364						C114, 214	1-121-410-51	47	25 V	elect				
Q403 ~ 406										C115, 215	1-108-846-11	0.056	50 V	mylar			
Q601		Transistor	2SD291						C116, 216	1-121-398-51	10	25 V	elect				
Q602, 603		Transistor	2SC1364						C117, 217	1-121-395-51	4.7	25 V	elect				
IC101, 201		Transistor	TA7122AP						C118, 218	1-108-806-11	0.015	50 V	mylar				
IC102, 202										C119, 219	1-108-808-11	0.022	50 V	mylar			
D301, 401		Diode	1T22A						C120, 220	1-108-810-11	0.033	50 V	mylar				
D601 ~ 604		Diode	SIB01-02						C121, 221	1-108-812-11	0.047	50 V	mylar				
D701 ~ 710										C122, 222	1-121-398-51	10	25 V	elect			
D711		Diode	RD-15E						C123, 223	1-102-074-51	1000 p	50 V	ceramic				
COILS																	
L101, 201	1-407-494-00	1.5 mH	microinductor						C124, 224	1-107-016-11	470 p	500 V	silvered mica				
L102, 202	1-407-286-00	2.2 mH	variable inductor						C125, 225	1-107-056-11	56 p	500 V	silvered mica				
L103, 203	1-407-284-00	1 mH	variable inductor						C126, 226	1-107-052-11	22 p	500 V	silvered mica				
TRANSFORMERS																	
T301, 401	1-427-299-00	Headphone							C127, 227	1-141-034-00	30 p ~ 120 p		trimmer				
T701	1-442-368-00	Power							C128, 228	1-102-975-11	100 p	50 V	ceramic				
CAPACITORS																	
All capacitors are in μ F unless otherwise indicated. (p = μ μ , elect = electrolytic)																	
C101, 201	1-121-398-51	10	25 V	elect					C301, 401	1-121-480-51	22	25 V	elect				
C102, 202	1-121-913-51	3.3	25 V	elect, low-noise					C302, 402	1-121-927-51	47	10 V	elect, low-noise				
C103, 203	1-102-074-51	1000 p	50 V	ceramic					C303, 403	1-101-881-51	47 p	50 V	ceramic				
									C304, 404	1-102-074-51	1000 p	50 V	ceramic				
									C305, 405	1-121-414-51	100	10 V	elect				
									C306, 406	1-101-881-51	47 p	50 V	ceramic				
									C307, 407	1-121-395-51	4.7	25 V	elect				
									C308, 408	1-121-398-51	10	25 V	elect				
									C309, 409	1-108-833-11	0.0047	50 V	mylar				
									C310, 410	1-108-815-11	0.082	50 V	mylar				
									C311, 411	1-121-422-51	220	25 V	elect				
									C312, 412	1-121-395-51	4.7	25 V	elect				
									C313, 413	1-102-969-51	33 p	50 V	ceramic				
									C314, 414								

<u>Ref. No.</u>	<u>Part No.</u>	<u>Description</u>		
C315, 415	1-121-352-51	47	10	elect
C316, 416	1-101-889-51	68 p	50 V	ceramic
C317, 417, C318, 418	1-121-395-51	4.7	25 V	elect
C319, 419	1-121-391-51	1	50 V	elect
C501	1-121-398-51	10	25 V	elect
C502	1-129-702-11	0.001	630 V	polypropylene
C503	1-108-867-11	0.033	50 V	mylar
C504	1-108-870-11	0.1	50 V	mylar
C505, 506	1-121-422-51	220	25 V	elect
C507	1-121-398-51	10	25 V	elect
C601	1-121-810-11	470	50 V	elect
C602	1-121-357-11	100	35 V	elect
C603	1-123-047-11	2200	25 V	elect
C604	1-108-870-61	0.1	50 V	mylar
C605	1-121-416-11	100	25 V	elect
C606	1-102-074-11	1000 p	50 V	ceramic
C607	1-108-867-11	0.033	50 V	mylar
C701 ~ 704	1-129-757-11	0.1	400 V	polypropylene
C705	1-121-004-11	220	160 V	elect
C706	1-121-388-11	1000	35 V	elect
C707, 708	1-117-064-11	0.5	350 V	metalized paper
C709	1-117-036-22	1.5 + 0.5	250 V	metalized paper
C710, 711	1-117-082-11	4	250 V	metalized paper
C712 ~ 716	1-129-757-11	0.1	400 V	polypropylene

RESISTORS

All resistors are in Ω , $\frac{1}{4}W$, $\pm 5\%$ carbon resistors (except particular type) are omitted, check schematic diagram for the resistance values. k = 1000, M = 1000k

R102, 202	1-244-721-71	100 k	low-noise
R103, 303	1-244-727-71	180 k	low-noise
R104, 204	1-244-673-71	1 k	low-noise
R106, 206	1-244-693-71	6.8 k	low-noise
R109, 209	1-244-721-71	100 k	low-noise
R110, 210	1-244-733-71	330 k	low-noise
R116, 216	1-222-774-00	10 k (B)	adjustable
R129, 229, R130, 230	1-224-033-00	20 k (A)	adjustable

<u>Ref. No.</u>	<u>Part No.</u>	<u>Description</u>		
R302, 402	1-244-717-71	68 k	low-noise	
R304, 404	1-244-681-71	2.2 k	low-noise	
R307, 407	1-244-705-71	22 k	low-noise	
R309, 409	1-244-689-71	4.7 k	low-noise	
R310, 410	1-244-691-71	5.6 k	low-noise	
R313, 413	1-222-771-00	1 k (B)	adjustable	
R315, 415	1-222-774-00	10 k (B)	adjustable	
R327, 427	1-222-773-00	4.7 k (B)	adjustable	
R330, 430	1-222-254-00	10 k (B)	adjustable	
R601	1-213-060-11	10	1 W fuse	
R605	1-222-776-11	47 k (B)	adjustable	
R701	1-206-455-11	4.7	2 W metal oxide	
R702	1-206-744-11	4.7 k	3 W metal oxide	
R703 ~ 705	1-206-316-11	330	5 W metal oxide	

SWITCHES

S101, 201	1-514-480-00	Push, 2 key; record/playback
S102, 103	1-516-646-00	Push, 2 key; BIAS, EQ
S301, 401	1-516-299-31	Push, 2 key; MONITOR
S501	1-516-644-00	Rotary-slide; TAPE SPEED
S701	1-516-277-00	Push, POWER
S702	1-514-730-00	Micro, solenoid hold
S703, 704		Micro, shut-off
S705 ~ 708	1-516-125-00	Lever-slide, function

JACKS

J101, 201	1-507-376-00	Phone, MICROPHONE
J102, 202	1-507-433-00	Phono, LINE IN
J301, 401	1-507-433-00	Phono, LINE OUT
J501	1-507-414-00	Binaural, HEADPHONE
J502	1-509-549-00	Connector, REC/PB

MISCELLANEOUS

CP501	1-464-029-00	Bias Osc Unit
F1	1-532-204-00	Fuse, 2 AT
F2	1-532-235-00	Fuse, 315 mA T
F3	1-532-066-00	Fuse, 400 mA T

<u>Ref. No.</u>	<u>Part No.</u>	<u>Description</u>
F4	1-532-204-00	Fuse, 2 A
F5	1-532-063-00	Fuse, 1 A
F6, 7	1-532-080-00	Fuse, 800mA
H101, 201	8-825-534-00	Head, playback; PF140-4202
H102, 202	8-825-511-00	Head, record; RF140-2902
H103, 203	8-825-547-00	Head, erase; EF18-2902A2
M1	8-832-624-22	Motor, capstan; IC-624H1
M2	8-832-624-19	Motor, take-up; UC-624K
M3	8-832-624-19	Motor, supply; UC-624K

<u>Ref. No.</u>	<u>Part No.</u>	<u>Description</u>
ME301, 401	1-520-216-00	Meter, level
PM701	1-454-074-00	Solenoid, brake
PM702	1-454-074-00	Solenoid, pinch roller
PM703	1-455-133-00	Solenoid, stop
	1-508-693-00	Pin, connector
	1-509-482-00	Socket, voltage selector
	1-509-546-00	Connector, AC IN
	1-518-115-00	Lamp, 6 V 35 mA
	1-535-506-00	Crimping Terminal

ACCESSORIES AND PACKING MATERIALS

<u>Part No.</u>	<u>Description</u>
1-534-049-31	Cord, connection; RK-74
1-534-819-00	Cord, power; DK-39 (UK)
3-540-512-00	Carton (UK)
3-540-513-00	Carton (AEP)
3-540-514-00	Cushion
3-540-517-00	Holder, power cord
3-780-510-00	Manual, instruction
3-793-010-20	Booklet, tape talk
X-3518-102-0	Reel Ass'y, R-7ES
X-3701-018-1	Tip, head cleaning

**SECTION 7
HARDWARE**

<u>Part No.</u>	<u>Description</u>	<u>Part No.</u>	<u>Description</u>
SCREWS			
All screws are Phillips (cross recess) type unless otherwise indicated. (-): slotted head.			
7-621-110-22	K 2.6 x 22	7-682-947-01	PSW 3 x 6
7-621-255-24	P 2 x 4	7-682-960-01	PSW 4 x 6
7-621-259-25	P 2.6 x 4		
7-621-259-45	P 2.6 x 6	7-682-961-01	PSW 4 x 8
7-621-259-55	P 2.6 x 8	7-683-137-00	(-) SC 3 x 3, set
		7-683-138-00	(-) SC 3 x 4, set
		7-683-247-00	(-) SC 4 x 6, w/hexagon head
		7-685-243-01	K 3 x 4
		7-685-561-01	B 4 x 12
			WASHERS
7-621-559-23	K 2.6 x 4	7-623-102-02	2.6 (small)
7-621-758-35	PSW 2.6 x 5	7-623-105-12	2
7-628-154-15	PS 2.6 x 6	7-623-106-01	4 (Black)
7-628-253-95	P 2.6 x 5	7-623-107-12	2.6 (middle)
7-682-123-01	P 2 x 3	7-623-108-12	3
7-682-148-11	P 3 x 8	7-623-205-11	2.6, spring
7-682-243-31	P 3 x 10, w/hexagon head	7-623-205-26	2, spring
7-682-247-01	K 3 x 6	7-623-208-12	3, spring
7-682-247-31	P 4 x 6, w/hexagon head		
7-682-256-04	RK 3 x 35		
			RETAINING RINGS
7-682-547-01	B 3 x 6	7-624-104-01	E 2
7-682-548-05	B 3 x 8	7-624-106-01	E 3
7-682-562-06	B 4 x 10	7-624-108-01	E 4
7-682-565-06	B 4 x 16	7-624-109-01	E 5
7-682-566-04	B 4 x 20	7-624-111-01	E 7
7-682-594-01	B 3 x 10		MISCELLANEOUS
7-682-624-01	PS 2 x 4	7-622-207-02	Nut 2.6
7-682-646-01	PS 3 x 5	7-623-508-11	Lug 3
7-682-647-01	PS 3 x 6		
7-682-648-01	PS 3 x 8	7-684-023-01	Nut 3
7-682-651-01	PS 3 x 14		
7-682-654-01	PS 3 x 25		
7-682-661-01	PS 4 x 8		

TC-645