

AEP Model
AUS Model
Canada Model
E Model
USA Model



STEREO TAPECORDER

SPECIFICATIONS

Power Requirements: AC 120V, 60Hz (Canada, USA)
 AC 100V, 110V, 117V, 125V, 220V,
 240V, 50/60 Hz (E)
 AC 110V, 127V, 220V, 240V,
 50/60 Hz (AEP, AUS)

Power Consumption: 38W (Canada, USA)
 48W (AEP, E, AUS)

Bias Frequency: Approx. 160kHz

Track System: Four track two channel stereo and mono

Reel Size: 7" maximum

Tape Speed: 19 cm/s (7 1/2 ips)
 9.5 cm/s (3 3/4 ips)
 4.8 cm/s (1 7/8 ips)

Frequency Response: SPECIAL (SONY SLH tape)

	NAB	DIN
19 cm/s (7 1/2 ips):	20~30,000 Hz	30~24,000 Hz
19 cm/s (7 1/2 ips):	30~25,000 Hz ±3dB	
9.5 cm/s (3 3/4 ips):	30~20,000 Hz	40~16,000 Hz

NORMAL (Standard tape)

	NAB	DIN
19 cm/s (7 1/2 ips):	20~25,000 Hz	30~20,000 Hz
19 cm/s (7 1/2 ips):	30~20,000 Hz ±3dB	
9.5 cm/s (3 3/4 ips):	30~17,000 Hz	40~13,000 Hz
4.8 cm/s (1 7/8 ips):	30~9,000 Hz	

Signal-to-Noise Ratio: NORMAL SPECIAL
 52 dB or better 55 dB or better

Distortion: 1.2%

Wow and Flutter: 19 cm/s (7 1/2 ips): 0.09% (RMS) weighted
 9.5 cm/s (3 3/4 ips): 0.12% (RMS) weighted
 4.8 cm/s (1 7/8 ips): 0.17% (RMS) weighted

Inputs: Two MICROPHONE inputs
 Impedance: low impedance
 Maximum sensitivity: -72 dB (0.2 mV)

Two LINE INputs
 Impedance: 100kΩ
 Maximum sensitivity: -22 dB (0.06V)
 REC/PB connector (AEP, E, AUS)
 Input impedance: 3.8kΩ

Outputs: Two LINE OUTputs
 Load impedance: more than 10kΩ
 Output level: 0 dB (0.78V) with 100kΩ load
 REC/PB connector (AEP, E, AUS)
 Output impedance: 3.3kΩ
 HEADPHONE output
 Load impedance: 8Ω

Semiconductors: 23 transistors, 5 diodes

Record Head: RF140-2902 (70Ω/1 kHz)

Playback Head: PF140-4202 (1kΩ/1 kHz)

Erase Head: EF18-2902A1 (1.6kΩ/160 kHz)

Motor: IC-624H1 (induction motor)

Dimensions: 418 (w) x 210 (h) x 392 (d) mm
 16 1/2 (w) x 8 5/16 (h) x 15 7/16 (d) inches

Weight: 10.6 kg, 23 lb 6 oz (Canada, USA)
 11.5 kg, 25 lb 6 oz (AEP, E, AUS)

SONY
 SERVICE MANUAL

TABLE OF CONTENTS

<u>Section</u>	<u>Title</u>	<u>Page</u>
	Specification	1
1	OUTLINE	
	1-1. Block Diagram	3
	1-2. External Views	4
	1-3. Internal Views	5
2	DISASSEMBLY	6
3	ADJUSTMENTS	
	3-1. Mechanical Adjustments	9
	3-2. Electrical Adjustments/Measurements	16
	3-3. Power Frequency Adaptation	28
4	DIAGRAMS	
	4-1. Level Diagrams	29
	4-2. Schematic Diagram	31
	4-3. Mounting Diagrams	33
	4-3-1. Tape Select Switch Circuit Board	33
	4-3-2. Power Supply Circuit Board	33
	4-3-3. Bias Osc Circuit Board	34
	4-3-4. Record Amp Circuit Board	35
	4-3-5. Playback Amp Circuit Board	36
5	EXPLODED VIEWS	
	5-1. Cabinet - top view -	37
	5-2. Head Deck - top view -	38
	5-3. Amplifier Chassis - top view -	39
	5-4. Chassis - top view -	41
	5-5. Packing	43
6	ELECTRICAL PARTS LIST	44
7	HARDWARE	47
	Hardware Nomenclature	47

*When ordering replacement parts, use PART NUMBERS listed in Parts List or shown in EXPLODED VIEW.
Parts List reference numbers should not be used.*

SECTION 1
OUTLINE

1-1. BLOCK DIAGRAM

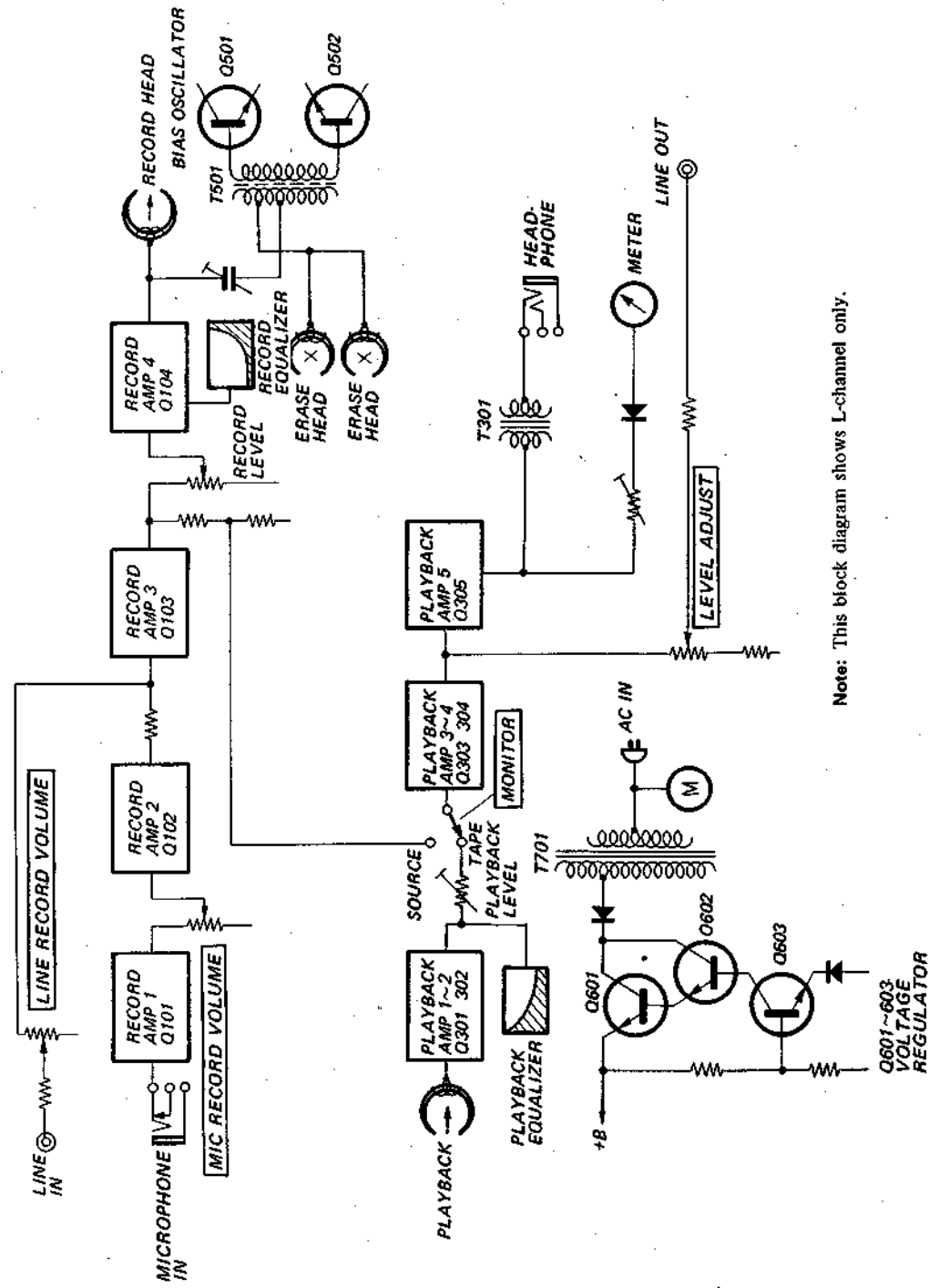

Note: This block diagram shows L-channel only.

1-2. MAJOR PARTS LOCATION

Front Panel

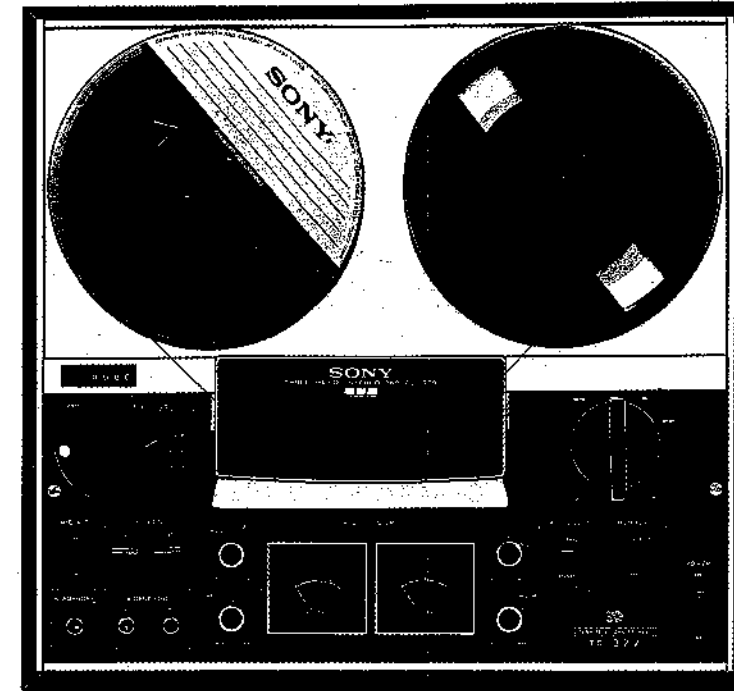

Side Panel

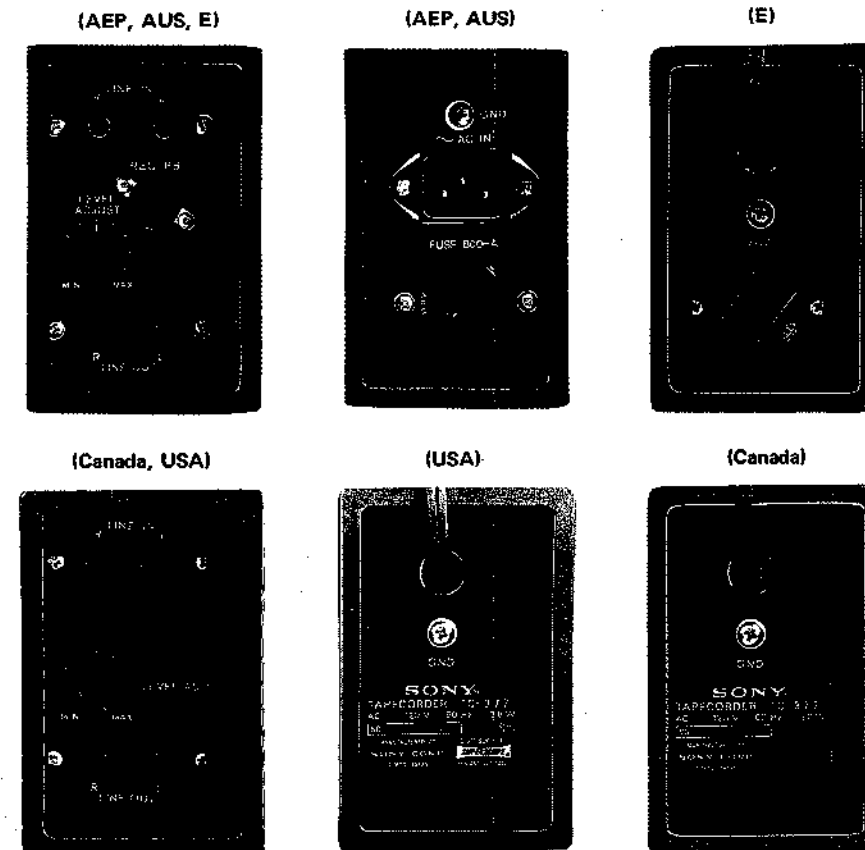

SECTION 2
DISASSEMBLY

1-3. INTERNAL VIEWS

Chassis Front

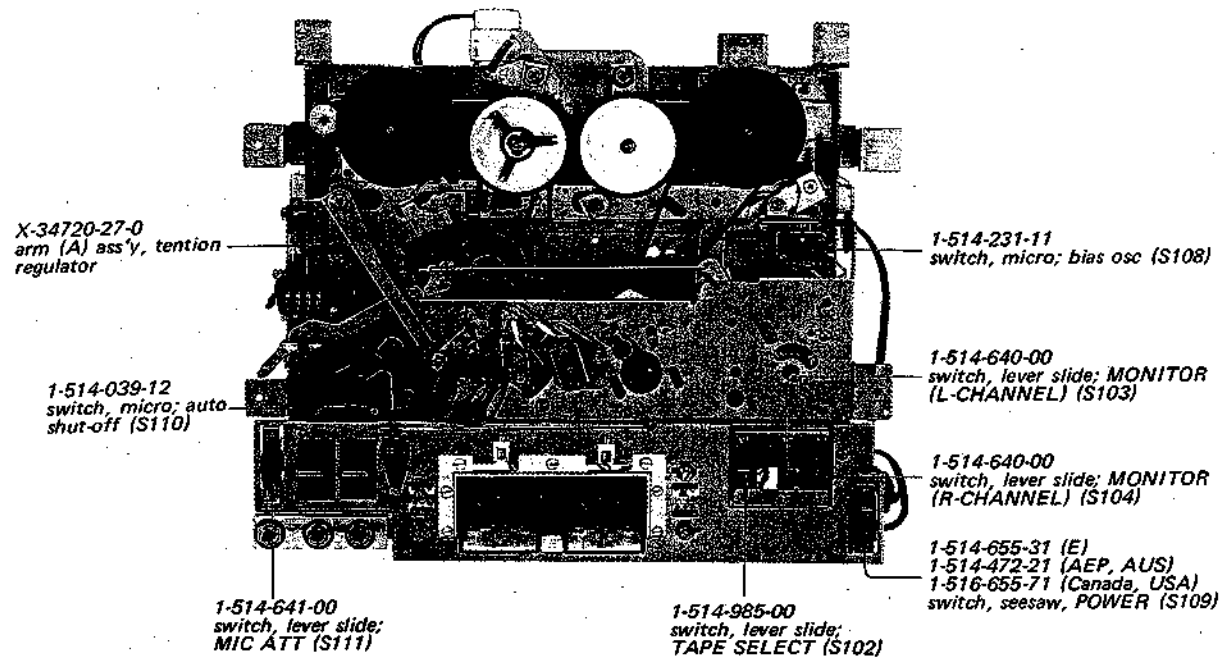

Chassis Rear

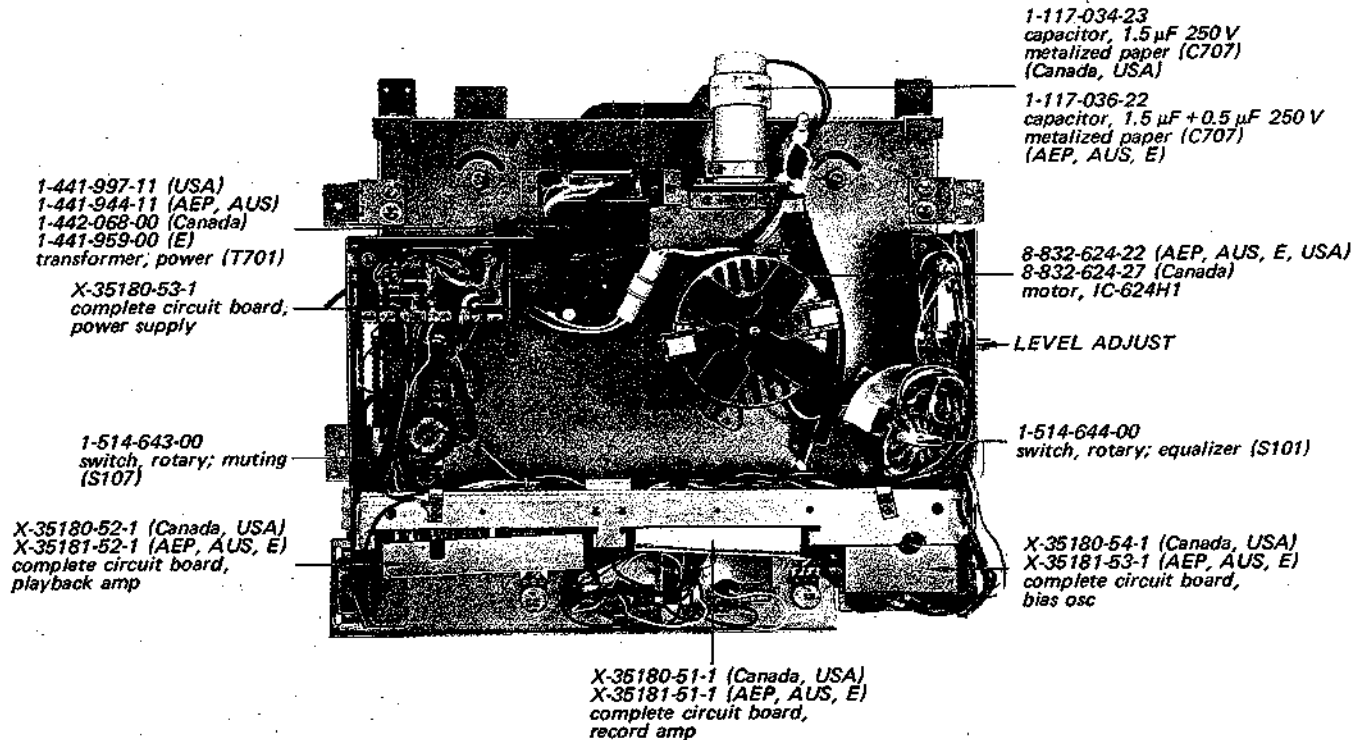

2-1. CABINET REMOVAL

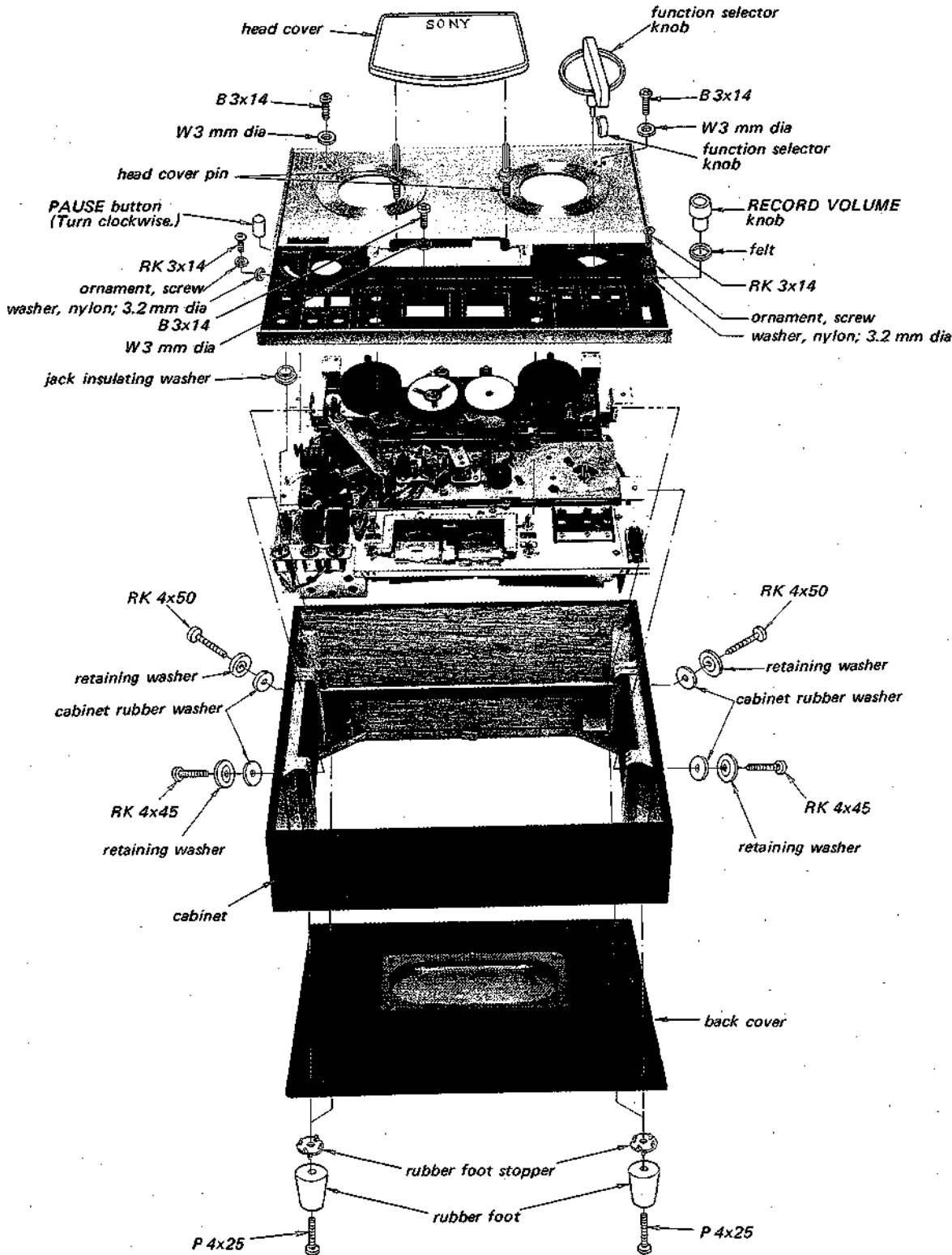

2-2. HEAD DECK REMOVAL

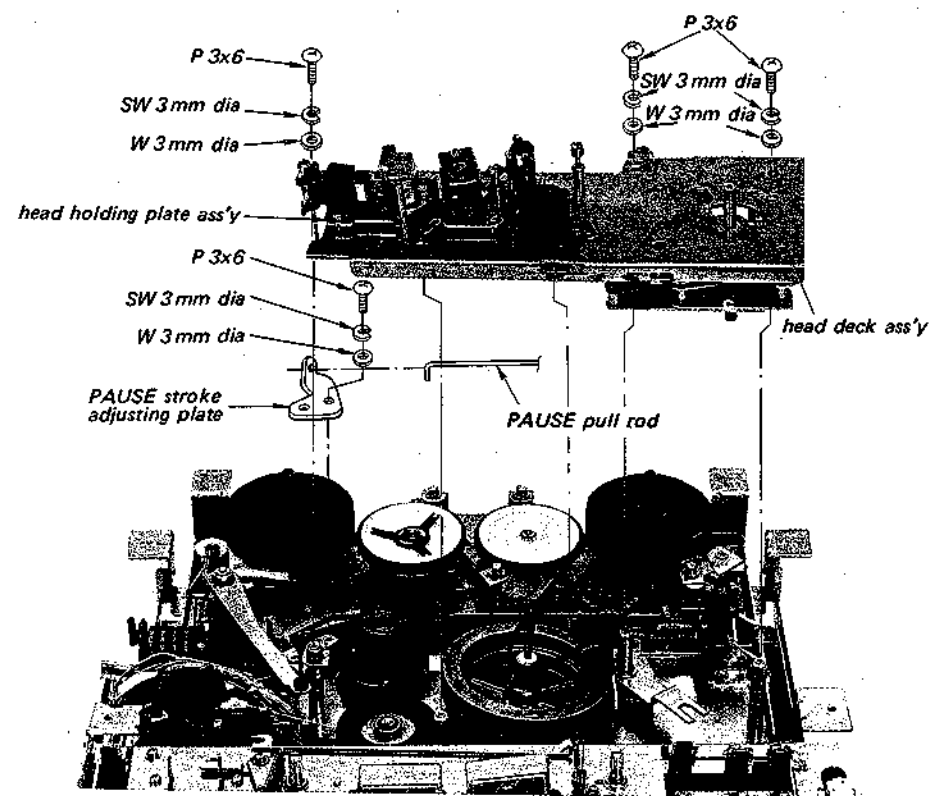

CAUTION

- (1) Never put the machine upside down on the hard plate with the head cover removed, or the pin of the tape shifter, the shut-off arm pin, the tension arm and others will be bent by the weight of the machine.
If it is necessary to put the machine upside down, put it on a soft cloth with the head cover attached.
- (2) Do not short-circuit B⁺ circuit to ground, or transistor Q601 will be broken.
- (3) When removing PAUSE button, turn it clockwise.
- (4) Turn on the power switch after being certain that the motor fan does not touch anything.

MEMO

A series of horizontal dotted lines for taking notes.

SECTION 3
ADJUSTMENTS

3-1. MECHANICAL ADJUSTMENTS

Precaution:

Do not use magnetized screwdriver for adjustments.

After adjustments, apply locking paint to the adjusted parts.

Tension Regulator Adjustment

STOP mode

1. Loosen the adjusting screw and adjust so that the clearance shown is 8 mm ($\frac{5}{16}$ ") after having been turned reel table counterclockwise by hand.

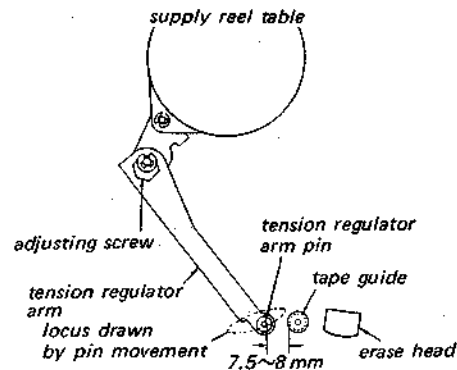

2. Tape should be in contact with tension regulator pin uniformly at beginning and end portion of it.

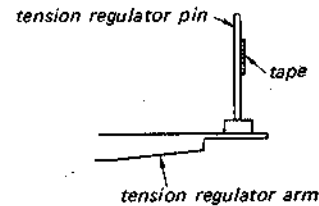

Tension Regulator Back-tension Adjustment
FWD and FF modes

This adjustment should be done after Tension Regulator Adjustment.

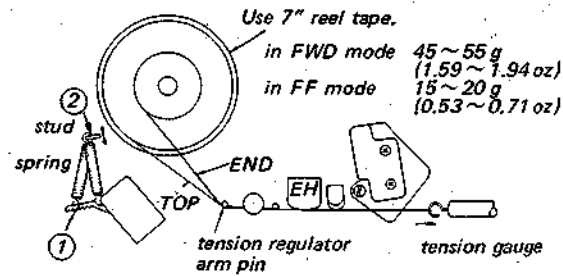

- 1 Adjust by changing the spring hook position.
- 2 If necessary, adjust by bending the stud or perform the tension regulator adjustment again.

Pinch Roller Pressure Check

STOP mode

1. Remove head deck ass'y. (See "HEAD DECK REMOVAL" on page 7)
2. Put dummy capstan into capstan bearing and be sure that the clearance between pinch levers (A) and (B) is approx. 0.5 mm ($\frac{1}{64}$ ").

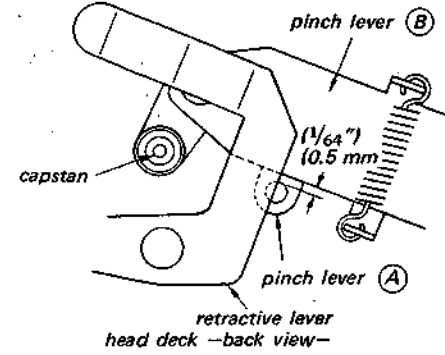

3. Be sure that the tension gauge indicates 800~1,000 g (1 lb 12 oz~2 lb 3 oz) when the pinch roller is detached from capstan in FWD mode.

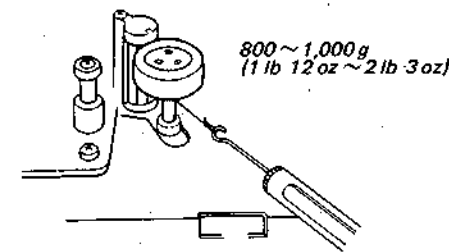

Bias Switch Position Adjustment

Loosen two screws and adjust by positioning the switch.

Switch should be turned ON in FWD mode, and with function selector knob changed slowly from FWD to STOP, record levers are released after the switch turns OFF.

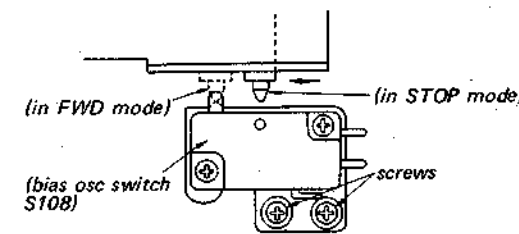

Pinch Roller Stroke Adjustment

1. Remove head deck (See page 7).
2. Loosen adjusting screw (1) so that pinch roller shaft comes in contact with retractive lever at position (A) in STOP mode.
3. Fix adjusting screw (1) while pushing the joint lever in the direction shown by arrow.
4. Put the dummy capstan into the capstan bearing and be sure that pinch roller shaft moves by approx. 3~4 mm ($\frac{1}{8}$ ~ $\frac{5}{32}$ ") on the surface of retractive lever when function selector knob is changed from STOP to FWD.
5. Be sure that the washer on pinch roller shaft does not come in contact with (C) position when function selector knob is changed slowly from FWD to FF.

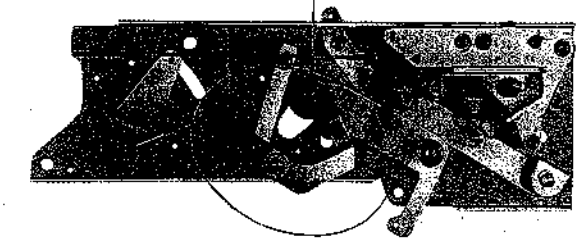
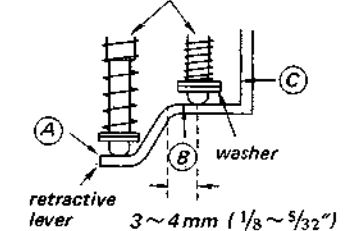
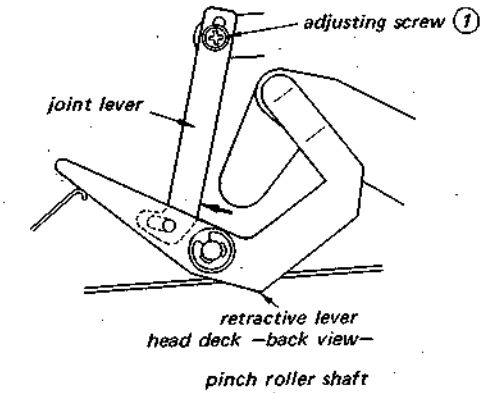

Head deck bottom view.

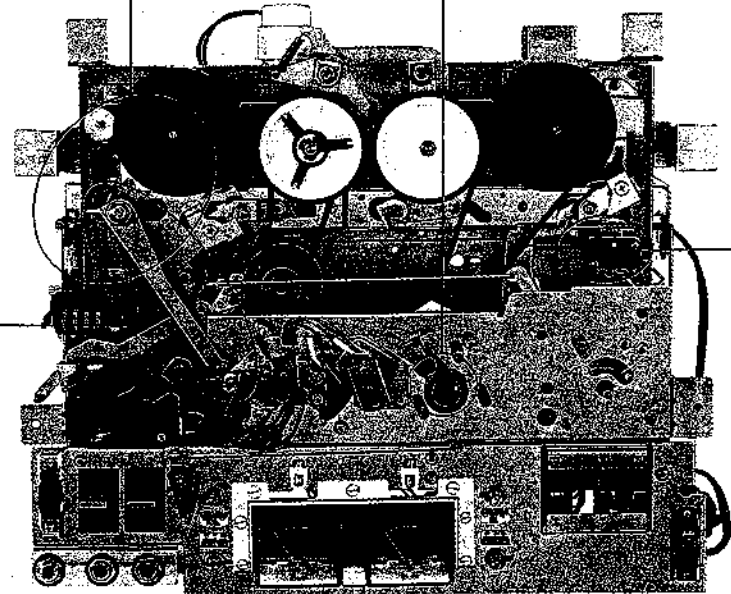

**PAUSE Adjustment
STOP mode**

This adjustment should be done after tension regulator adjustment.

1. Adjust screw (A) so that the distance between the end of PAUSE pull rod and PAUSE stroke adjusting plate is 4~5 mm ($\frac{5}{32}$ "~ $\frac{3}{16}$ " in STOP mode.
2. Be sure that the clearance between pinch roller and capstan is more than 1 mm ($\frac{1}{32}$ " in) when pulling the PAUSE lever in FWD mode, and PAUSE button is not locked when pulling it in STOP mode.
3. Adjust screw (B) so that the clearance between tension regulator arm and PAUSE leaf spring is 2~3 mm ($\frac{1}{8}$ " in) in STOP mode. Brake should work, when pulling the PAUSE lever in FWD mode.

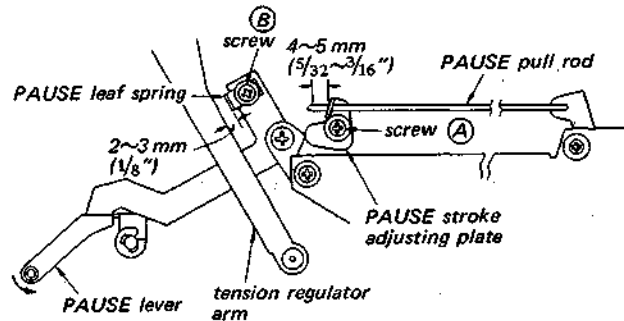

**Speed Selector Cam Position Adjustment
FWD mode**

Loosen the screw and adjust to locate the idler arm pin in the stopper slot (2) shown, at 19 cm/s tape speed.

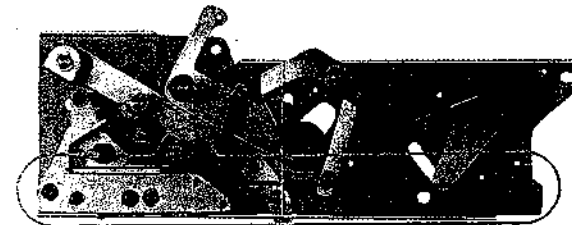
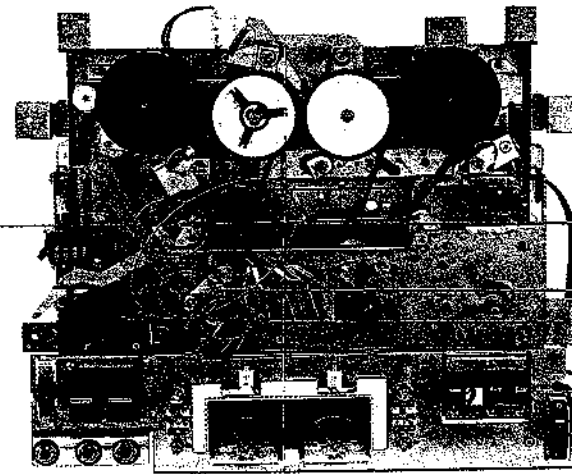
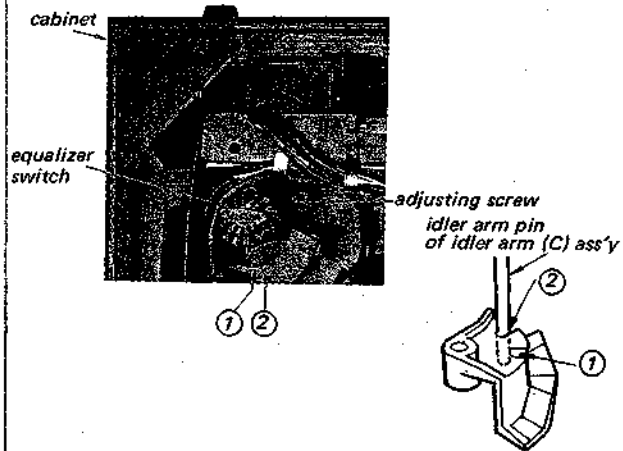

Head deck bottom view.

**Shut-off Mechanism Adjustment
STOP mode**

1. Loosen two screws (A) and adjust by positioning the shut-off lever holding plate ass'y so that the shut-off mechanism is locked when the clearance between the shut-off arm end and head deck is 6 mm ($\frac{15}{64}$ " in), and shut-off mechanism is released completely when it is ($\frac{3}{64}$ " in).
2. Adjust screw (B) so that the clearance between shut-off levers (B) and (H) is 0.3~0.6 mm ($\frac{1}{64}$ " in) in STOP mode.

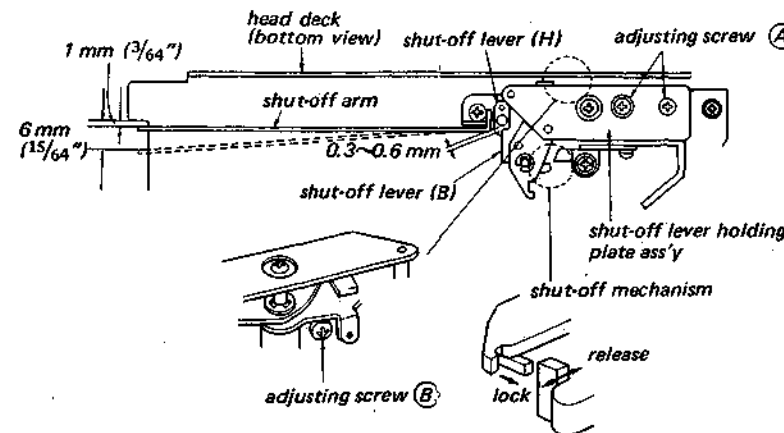

**Capstan Idler Position Adjustment
FWD mode**

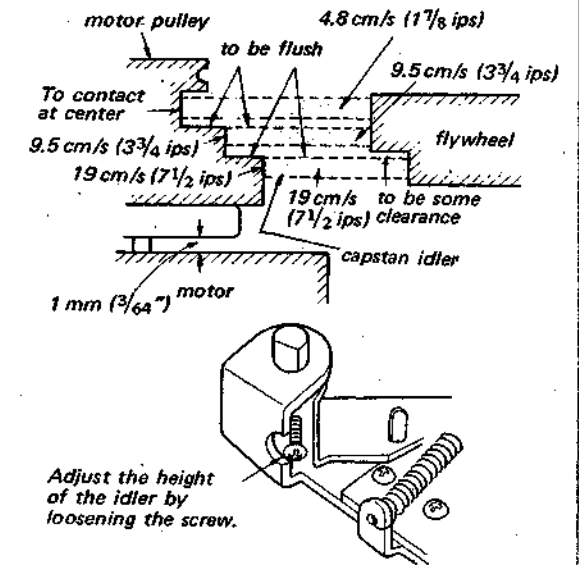

After adjustment, capstan idler should not come in contact with flywheel and 60 Hz motor pulley in STOP mode and the clearance between capstan idler and 50 Hz motor pulley is more than 3 mm ($\frac{1}{8}$ " in) in STOP mode.

**Idler Arm (C) Stroke Check
FWD mode**

At 4.8 cm/s ($1\frac{7}{8}$ ips) tape speed:

50 Hz	clearance is more than 0.6 mm ($\frac{1}{64}$ " in)
60 Hz	some clearance

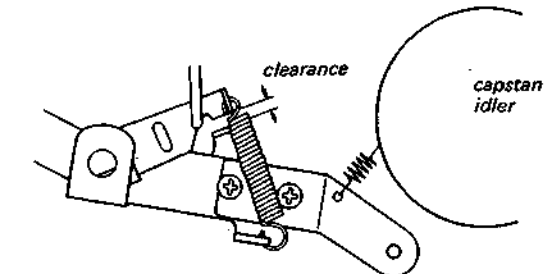

**Scrape Flutter Filter Roller Check
FWD mode**

At 4.8 cm/s ($1\frac{7}{8}$ ips) tape speed

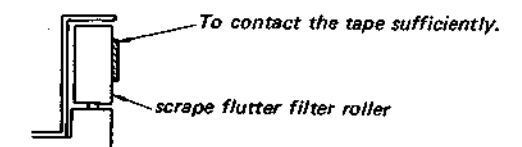

FF and REW Torque Adjustment
FF and REW modes

Adjust by changing the position of leaf spring to obtain the specified values on torque meter. (Read the values when driving idler is forced to stop the motion.)

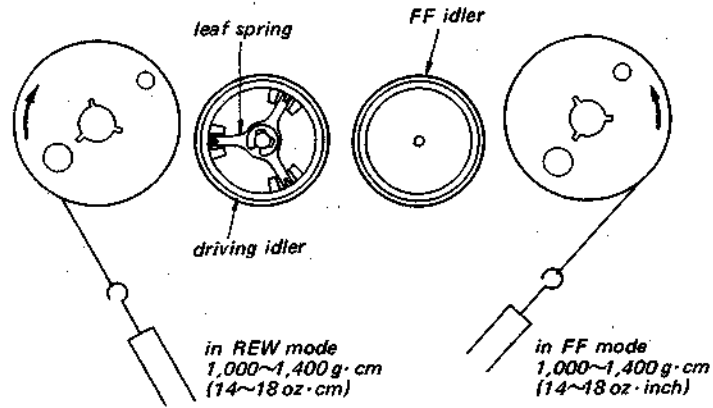

FWD Torque Adjustment
FWD mode

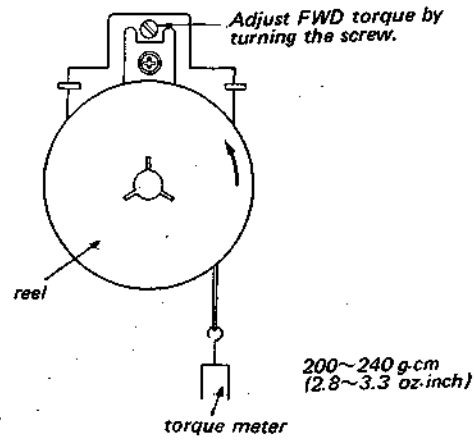

Brake Adjustment
STOP mode

supply brake torque	direction A	500~750 g·cm (6.96~10.4 oz·inch)	take-up brake torque	direction C	400~550 g·cm (5.56~7.65 oz·inch)
	direction B	1,000~1,800 g·cm (13.9~25 oz·inch)		direction D	1,600~2,200 g·cm (22.2~30.6 oz·inch)

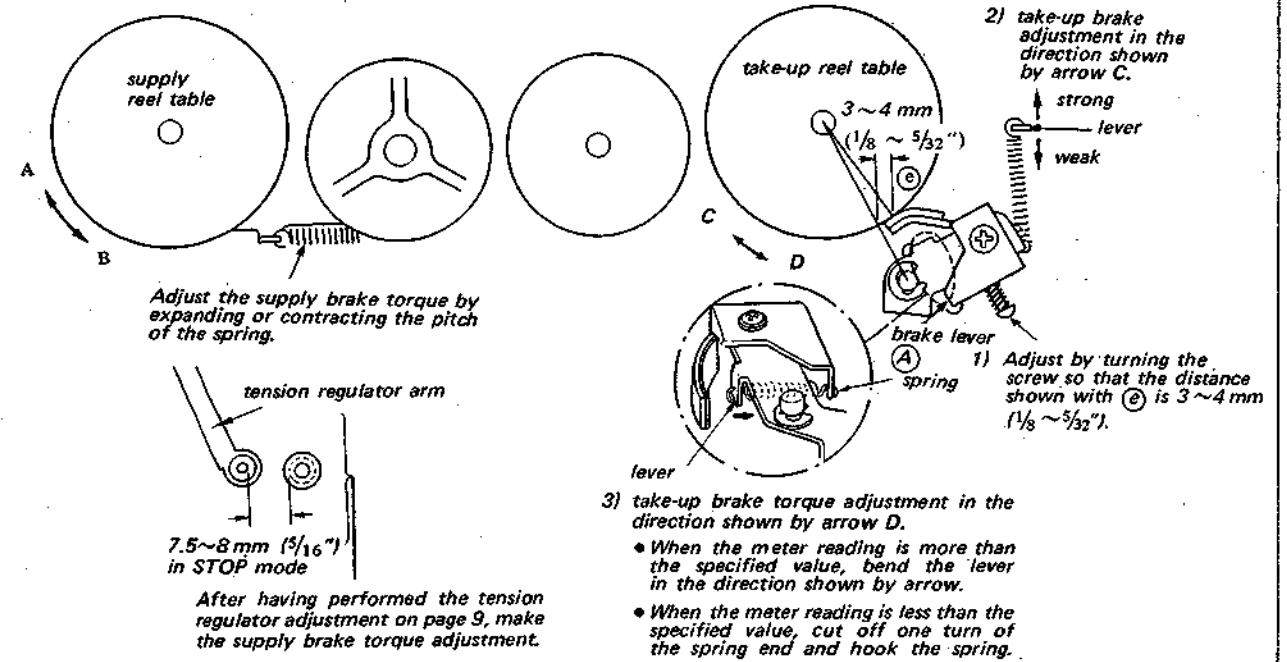

Reel Table Height Adjustment
FWD, REW & FF modes

- Adjust the height of reel table by adding or removing the adjusting washers (A, B) so that tape does not come in contact with reel flange in FWD, REW & FF modes.
- Perform tension regulator back-tension adjustment on page 9 and FWD torque adjustment.

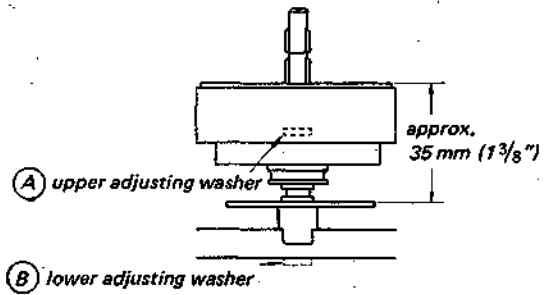

FF and Driving Idler Height Adjustment
STOP mode

Adjust the height of idler by adding or removing the nylon washer.

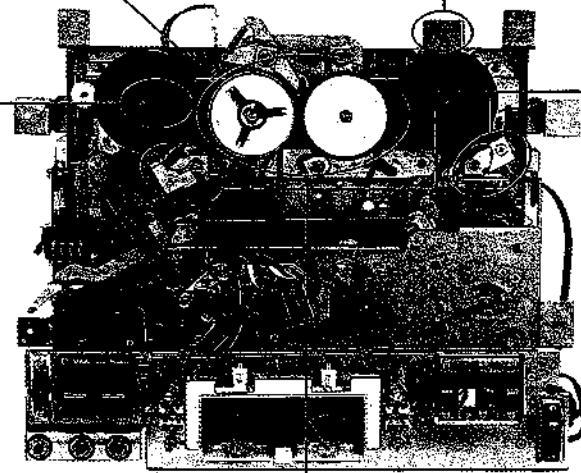
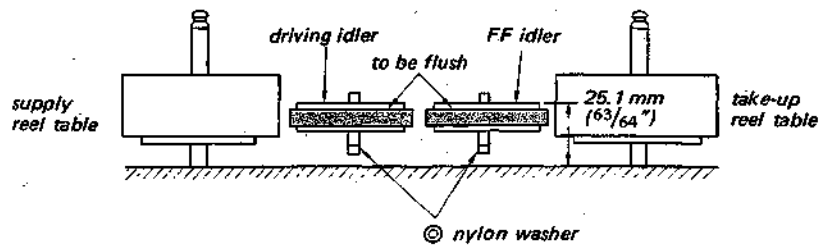

Tape Slack Check

Place the machine in vertical position and thread tape with 7" reel.

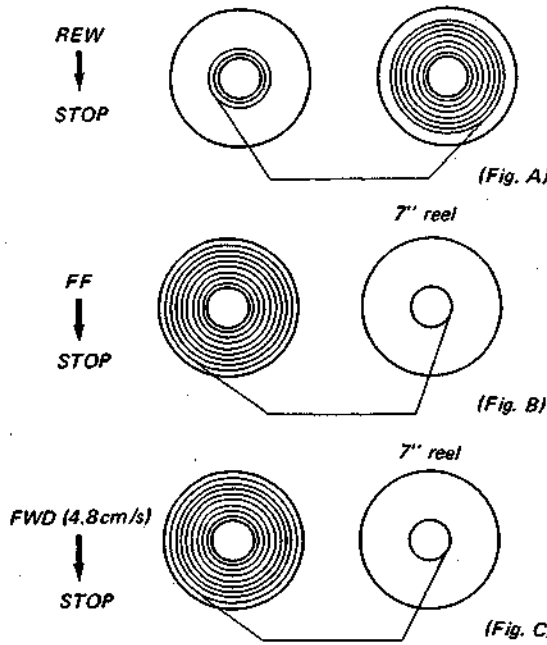

Be sure not to slack the tape in the following conditions.

Portion of Tape	Function Selector Knob
end portion of tape	REW → STOP (Fig. A)
beginning of tape	FF → STOP (Fig. B)
beginning of tape	Pull PAUSE lever in FWD mode at 19 cm/s (7 1/2 ips).
beginning of tape	FWD → STOP at 4.8 cm/s (1 7/8 ips) (Fig. C)

**Flywheel Brake Check
REW mode**

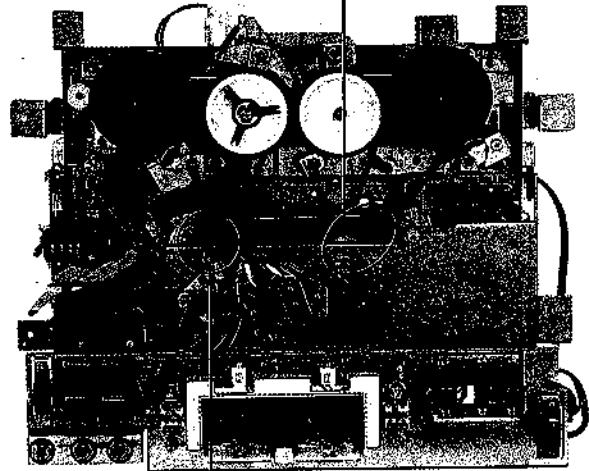
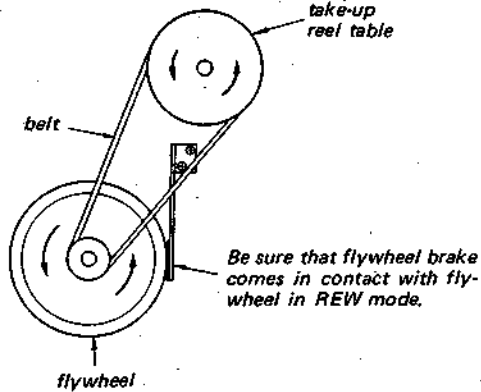

Tape Speed Adjustment

1. Playback SONY speed check tape (SPC-47) at 19 cm/s (7½ ips) tape speed in horizontal position. Read digital frequency counter connected to LINE OUT jack.
2. If the counter reading is out of 3,960 ~ 4,040 Hz, replace with the motor pulley with identification mark shown below.
(As for part No. of motor pulley, refer to page 28.)

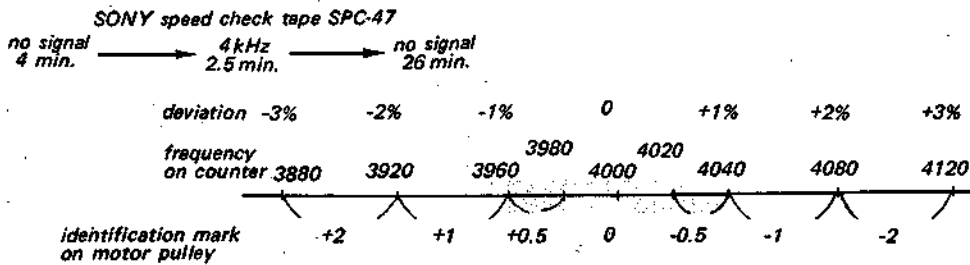

	19cm/s (7½ ips)	9.5cm/s (3¾ ips)	4.8cm/s (1⅞ ips)
Deviation (%)	±1.5	±1.5	±1.5
Variation Limit (%)	1	1	1

1. Tape Path Adjustment

A. Tape Guide (left) Adjustment

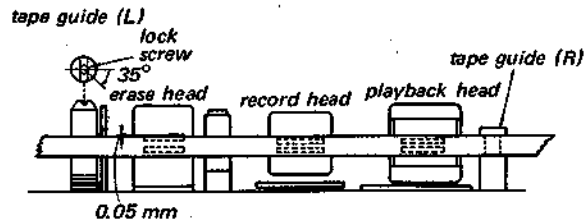

Procedure:

1. Thread a tape and place unit in playback mode.
2. Loosen the lock screw and align the upper edge of the erase head core and that of the tape by turning tape guide (L).
3. Turn tape guide (L) clockwise by approximately 35 degrees from the position obtained in the preceding step so that the upper edge of the tape is approximately 0.05 mm (2 mil) lower than the upper edge of the erase head core.
4. Fix the tape guide with the lock screw.

B. Record and Playback Head Preadjustment

(Rough adjustment for Playback Head Angle Adjustment and Playback Head Azimuth Adjustment)

Note: This adjustment and the following adjustments (Playback Head Angle Adjustment and Playback Head Azimuth Adjustment) should be repeated alternately several times.

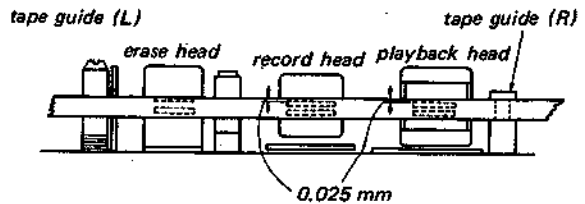

Procedure:

1. Align the upper edges of record and playback head cores and that of the tape by evenly turning the record and playback head height adjusting screws.
2. Turn record and playback head height adjusting screws clockwise by approximately 15 degrees so that the upper edges of record and playback head cores are 0.025 mm (1 mil) lower than that of the tape and memorize the angle of turns.
3. Turn zenith adjusting screws by the same angle of turns to the same direction of record and playback head height adjusting screws.
4. Thread SONY tape super 150 or PS-2 and place unit in playback mode at 19 cm/s (7½ ips).
5. Make the tape loose a little by pushing the tension regulator arm pin in the direction shown by arrow and then adjust playback head and record head zenith adjusting screws to obtain the reflection of light as shown.

Adjustment Location:

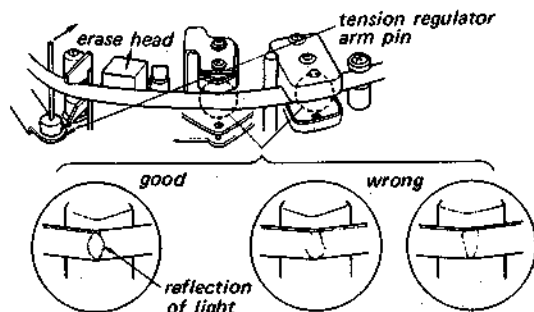
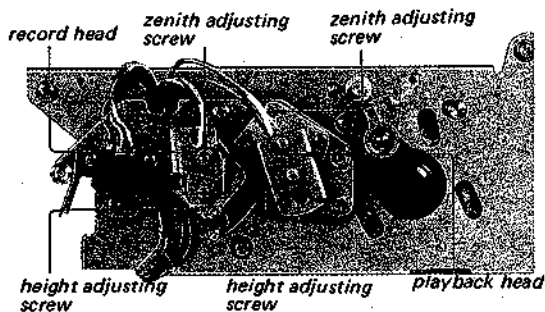

2. Tape Curl Adjustment

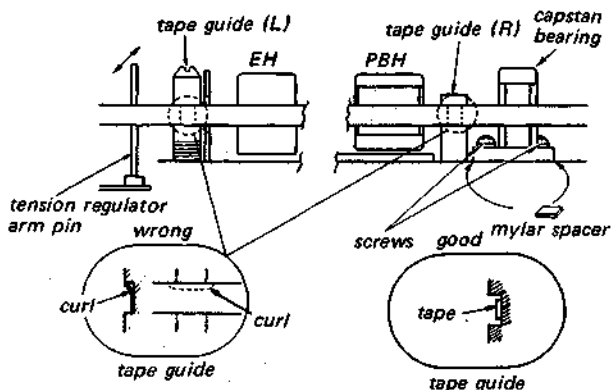

Procedure:

1. Thread SONY tape super 200 (thin tape) and place unit in playback mode at 4.8 cm/s (17/8 ips) tape speed.
2. Be sure that the tape comes in contact with two tape guides exactly as shown.
 - a) If tape is curled at tape guide (L), adjust by bending tension regulator arm pin with fingers.
 - b) If tape is curled at tape guide (R), loosen two capstan bearing holding screws and adjust by adding or removing the mylar spacer.

Note: After adding or removing the mylar spacer (0.1 mm thick), perform playback head zenith adjusting screw. (See "Record and Playback Head Preadjustment" on page 17.)

3. Playback Head Angle Adjustment

Control/Switch Setting:

- TAPE SELECT switch: NORMAL
- TAPE SPEED selector: 7½ ips (19 cm/s)
- MONITOR switch: TAPE

Procedure:

1. Mode: playback

J-19-F1
(1st tone 10kHz)

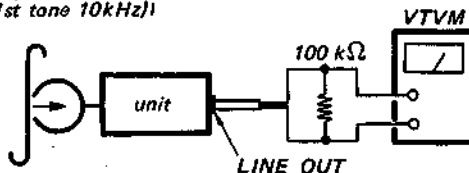

2. Adjust angle-adjusting screws for maximum VTVM reading.
3. Apply back-tension by holding lightly the supply reel table, reproducing the alignment tape, and then adjust the angle of the head by loosening two angle-adjusting screws so that VTVM reading on both L-CH and R-CH does not rise.

Note: Unless playback head is installed at correct angle, VTVM reading will rise.

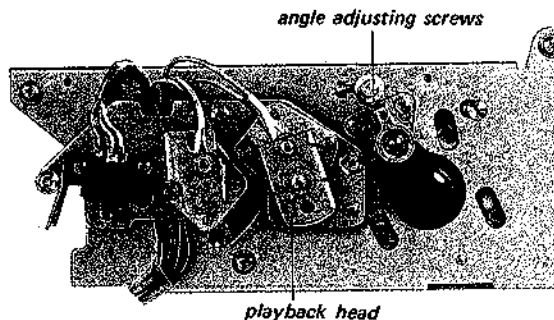

4. Playback Head Azimuth Adjustment

Control/Switch Setting:

TAPE SELECT switch: NORMAL
 TAPE SPEED selector: 7½ ips (19 cm/s)
 MONITOR switch: TAPE

Procedure:

1. Be sure that playback head is fixed sufficiently to head deck with holding screw as shown below and tape path adjustment has been made.
2. Mode: playback

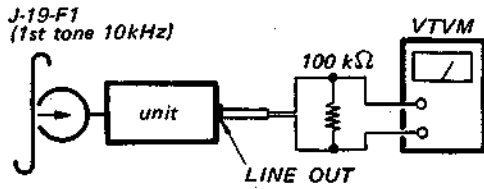

3. Adjust azimuth adjusting screw for maximum VTVM reading.

Note: If azimuth angles of L-CH and R-CH are not the same, set the screw midway between two screw positions.

Adjustment Location:

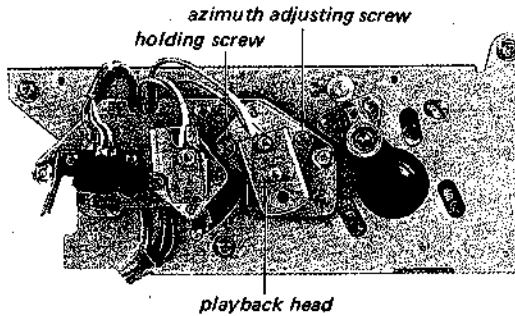

5. Playback Head Phase Check

Control/Switch Setting:

TAPE SELECT switch: NORMAL
 TAPE SPEED selector: 7½ ips (19 cm/s)
 MONITOR switch: TAPE

Procedure:

1. Mode: playback

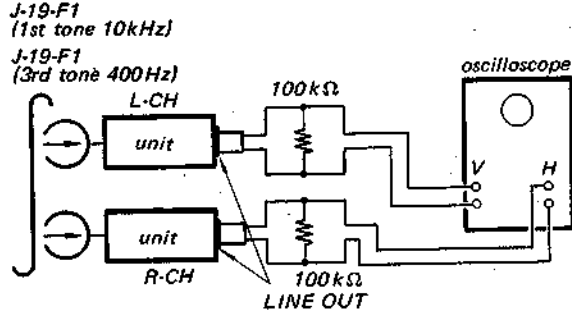

- 2.

Adjust	On the oscilloscope			
azimuth adjusting screw	 in-phase	 within 30°	 90°	 more than 90°
(400 Hz)	good	wrong		
(10 kHz)	good		wrong	

Note: If necessary, finely adjust the playback head azimuth adjusting screw.

6. Playback Output Level Adjustment and Level Meter Calibration

Control/Switch Setting:

- TAPE SELECT switch: NORMAL
- TAPE SPEED selector: 7½ ips (19 cm/s)
- MONITOR switch: TAPE

Procedure:

1. Mode: playback

J-19-F1
(2nd tone, 400 Hz)

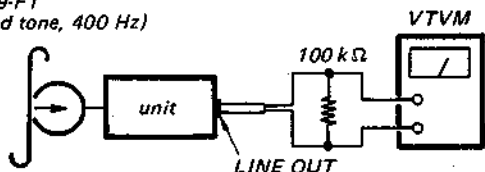

2. Adjust R316, R416 for 0 dB (0.78V) VTVM reading.
3. Adjust R327, R427 for 0 reading on RECORD LEVEL meters.
4. Change TAPE SELECT switch to SPECIAL and be sure that VTVM reading is -2 dB ~ -3 dB (0.62~0.55V).

Adjustment Location:

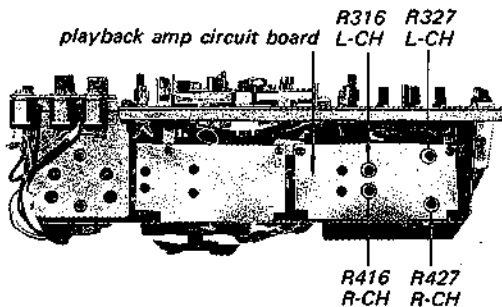

7. Playback Equalizer Adjustment

Control/Switch Setting:

- TAPE SELECT switch: NORMAL
- TAPE SPEED selector: 7½ ips (19 cm/s)
- MONITOR switch: TAPE

Procedure:

1. Mode: playback

J-19-F1
3rd tone, 400 Hz

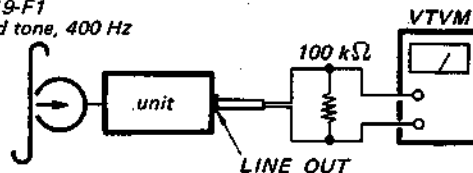

Memorize VTVM reading.

2. Mode: playback

J-19-F1
4th tone, 10 kHz

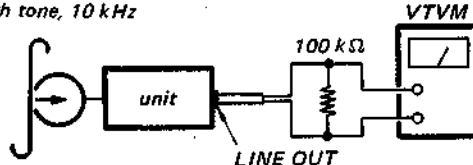

Adjust R313, 413 to obtain the same VTVM reading as in step 1.

3. Playback the following tones and make sure that each tone output level deviation against 3rd tone is as follows.

	Tone	4th	5th	6th	7th
J-19-F1	Frequency (Hz)	10k	7k	80	40
Level Deviation from 3rd tone (400Hz)	L-CH	0±2dB	0±2dB	2±2dB	4±2dB
	R-CH			2.5±2dB	4.5±2dB

Adjustment Location:

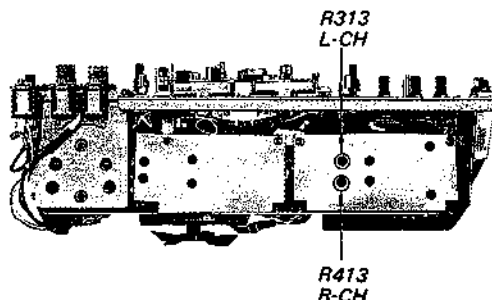

8. Playback S/N Ratio Check

Control/Switch Setting:

TAPE SELECT switch: NORMAL
 TAPE SPEED selector: 7½ ips (19 cm/s)
 MONITOR switch: TAPE

Procedure:

1. Mode: playback

J-19-F1
 2nd tone 400Hz

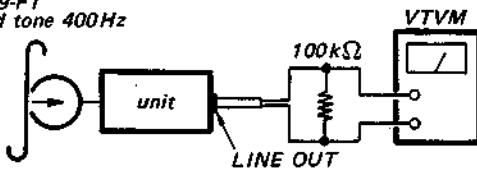

2. VTVM reading should be 0 dB (0.78V). If not, make playback output level adjustment again.
3. With no tape threaded, keep on pushing shut-off lever with finger.

Mode: playback

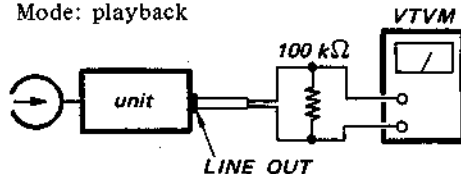

4. Be sure that VTVM reading is less than -48 dB (3 mV).

Note: S/N ratio may change by reversing the sense of motor leads.

9. Record Head Azimuth and Track Position Adjustment

Control/Switch Setting:

TAPE SELECT switch: NORMAL
 TAPE SPEED selector: 7½ ips (19 cm/s)
 MONITOR switch: TAPE
 LINE RECORD
 VOLUME control: See page 16

Procedure:

1. Mode: record

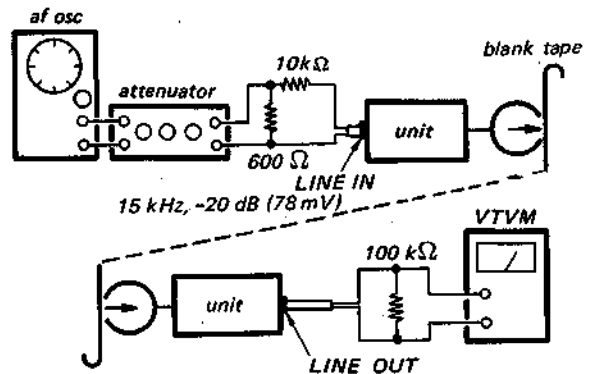

2. Adjust azimuth adjusting screw for maximum VTVM reading.

Note: If the maximum value of L-CH and R-CH outputs can not be obtained at the same angle, adjust the screw midway between two screw positions. (That value should not be fallen more than 1 dB from the maximum value.)

3. Supply a 1 kHz signal of -10 dB (0.24 V) into R-CH LINE IN jack and record the signal on the blank tape.
4. Adjust the height adjusting screw for maximum VTVM reading and memorize the angle of turns of the screw.
5. Turn the zenith adjusting screw by the same angle of turns obtained in preceding step 4.
6. After the adjustment, check tape path adjustment on page 17 again.

Adjustment Location:

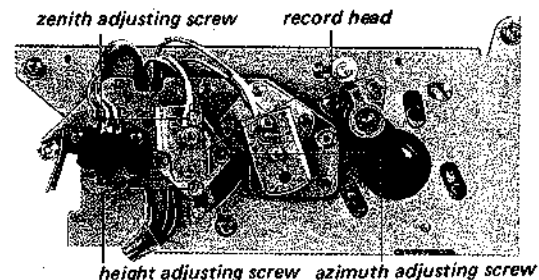

10. Record Head Phase Check

Control/Switch Setting:

- TAPE SELECT switch: NORMAL
- TAPE SPEED selector: 7½ ips (19 cm/s)
- MONITOR switch: TAPE
- LINE RECORD
- VOLUME control: See page 16

Procedure:

1. Make the playback head phase check on page 19 first.
2. Mode: record

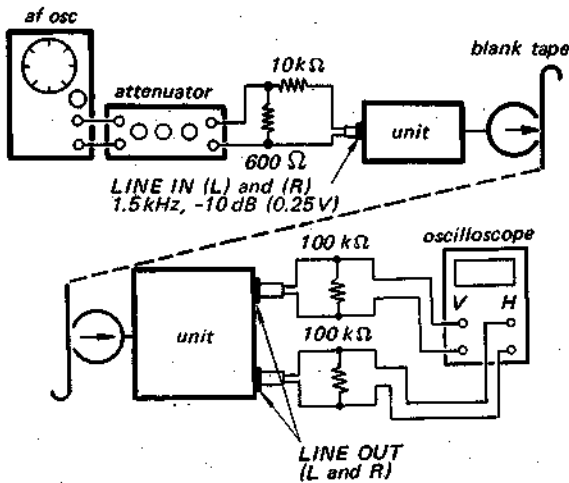

3.

Adjust	On the oscilloscope
azimuth adjusting screw	

Note: If necessary, finely adjust record head azimuth adjusting screw.

11. Trap Coil Adjustment

Control/Switch Setting:

- TAPE SELECT switch: NORMAL
- TAPE SPEED selector: 7½ ips (19 cm/s)
- MIC RECORD
- VOLUME control: MIN (fully counterclockwise)

Procedure:

1. Connect a VTVM across the check point and ground as shown.

(RECORD AMP CIRCUIT BOARD)

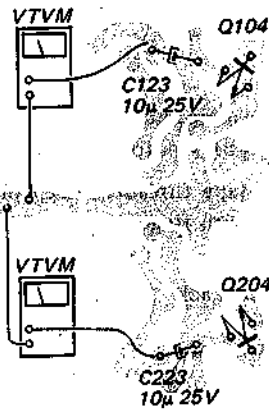

2. Place unit in record mode without tape.
3. Adjust L104, L204 to obtain the minimum VTVM reading (less than -7 dB, 0.35V).

Adjustment Location:

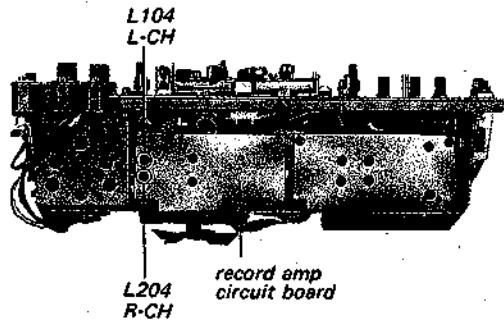

12. Record Bias Adjustment

Control/Switch Setting:

TAPE SELECT switch: NORMAL
 TAPE SPEED selector: 7½ ips (19 cm/s)
 MONITOR switch: TAPE
 LINE RECORD
 VOLUME control: See page 16

Procedure:

1. Be sure that trap coil adjustment has been made.
2. Mode: record

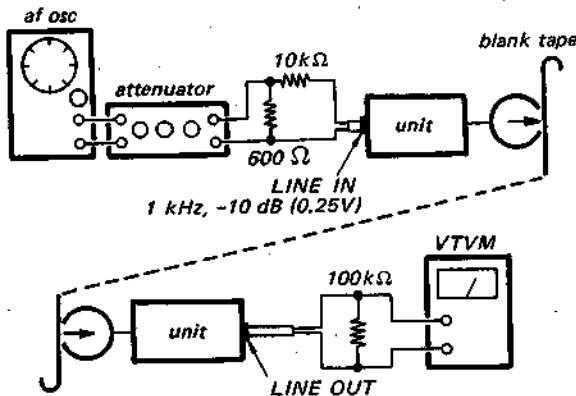

3. Turn the bias adjusting trimmer capacitors C503, C504 counterclockwise for maximum VTVM reading and then turn the capacitor counterclockwise so that VTVM reading drops 0.5 dB from the maximum value.
4. After the adjustment, be sure that voltage across record head is approximately 14V on VTVM and it decreases, as TAPE SPEED selector is changed to 3¾ ips (9.5 cm/s) and then 17/8 ips (4.8 cm/s).

Adjustment Location:

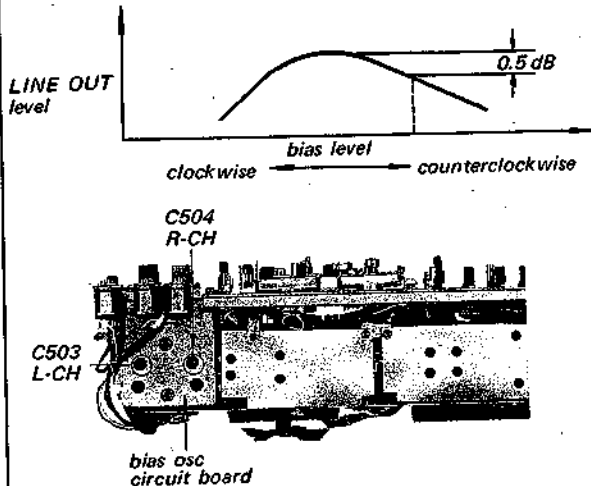

13. Record Level Adjustment

Control/Switch Setting:

TAPE SELECT switch: NORMAL
 TAPE SPEED selector: 7½ ips (19 cm/s)
 MONITOR switch: TAPE
 LINE RECORD
 VOLUME control: See page 16

Procedure:

1. Mode: record

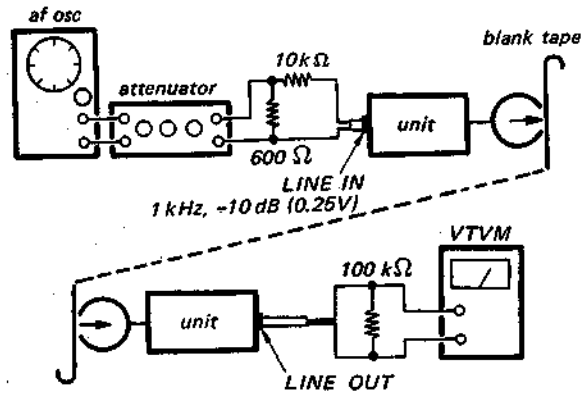

2. Adjust R128, R228 for 0 dB (0.78V) VTVM reading.
3. Be sure that VTVM reading is 0 dB (0.78V) when changing MONITOR switch from TAPE to SOURCE position and the pointer of RECORD LEVEL meter stays at "0".
4. When TAPE SELECT switch is changed to SPECIAL with MONITOR switch to SOURCE, VTVM reading should decrease approx. 1.5 dB.

Adjustment Location:

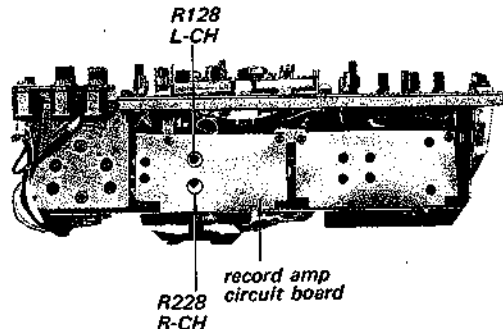

14. Dummy Coil Adjustment

Control/Switch Setting:

- TAPE SELECT switch: NORMAL
- TAPE SPEED selector: 7½ ips (19 cm/s)
- MONITOR switch: TAPE
- LINE RECORD
- VOLUME control: See page 16

Procedure:

1. Mode: stereo record

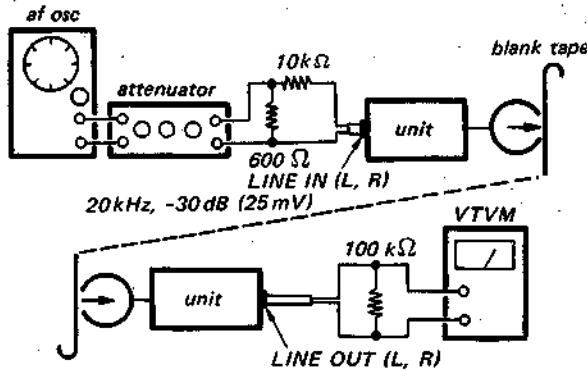

2. Memorize VTVM readings.
3. Set L-channel (R-channel) only in record mode.
4. Adjust L502 (L501) with non-magnetic screwdriver, taking care not to break the core, so that VTVM reading is the same as that obtained in step 2.

Adjustment Location:

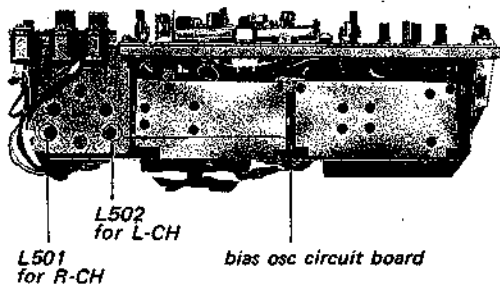

15. Erase Ratio Measurement

Control/Switch Setting:

- TAPE SELECT switch: NORMAL
- TAPE SPEED selector: 7½ ips (19 cm/s)
- MONITOR switch: TAPE
- LINE RECORD
- VOLUME control: See page 16

Procedure:

1. Mode: stereo record

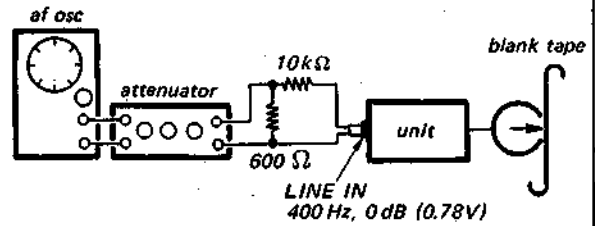

2. Rewind half of the recorded part.
3. Mode: stereo record (erase)

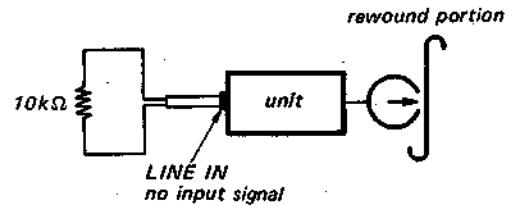

4. Mode: playback

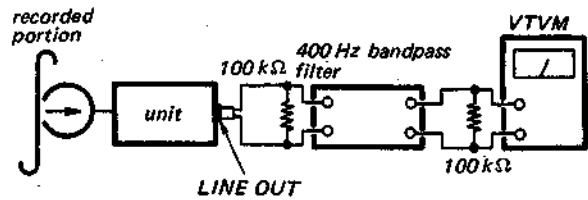

Specification:

Recorded Signal	VTVM Reading
1 kHz	level difference: greater than 65 dB
erased portion	

16. Overall Frequency Response Measurement

Control/Switch Setting:

- TAPE SELECT switch: NORMAL and SPECIAL
- TAPE SPEED selector: 7½ ips (19 cm/s)
3¾ ips (9.5 cm/s)
and 1⅞ ips (4.8 cm/s)
- MONITOR switch: TAPE
- LINE RECORD
- VOLUME control: See page 16

Procedure:

1. Mode: record

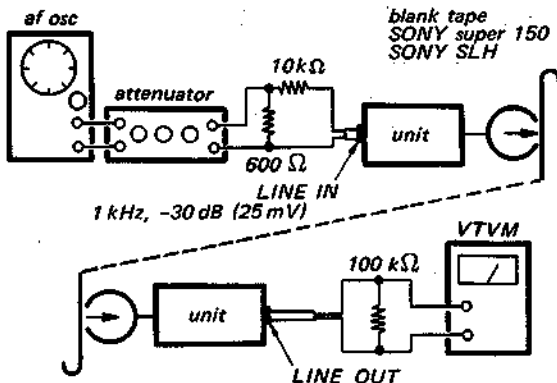

2. Level Deviation from 1 kHz signal.
(for both SPECIAL and NORMAL)

Frequency Tape speed	50 Hz	100 Hz	5 kHz	7 kHz	12.5 kHz	20 kHz
19 cm/s	±3 dB	±3	±3	±3	±3	+3 -4
9.5 cm/s	+3 -6	±3	±3	±3	+3 -4	
4.8 cm/s	+4 -5	+5 -1	+1 -6			

Note: When recording signal on SONY tape "super 150", set TAPE SELECT switch to NORMAL and on SONY SLH tape, to SPECIAL.

17. Overall S/N Ratio Measurement

Control/Switch Setting:

- TAPE SELECT switch: NORMAL and SPECIAL
- TAPE SPEED selector: 7½ ips (19 cm/s)
- MONITOR switch: TAPE
- MIC RECORD
- VOLUME control: See page 16

Procedure:

1. Mode: record

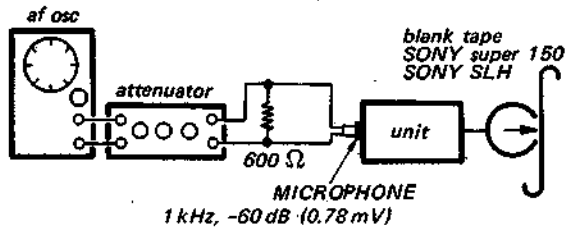

2. Mode: record

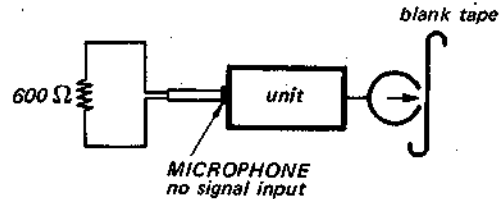

3. Mode: playback

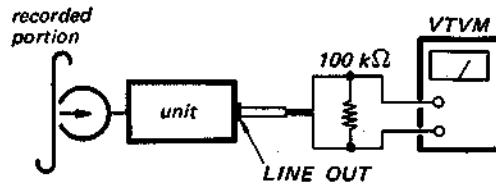

Specification:

Recorded Signal	VTVM Reading	
	NORMAL	SPECIAL
1 kHz	level difference: greater than 45 dB	level difference: greater than 47 dB
no signal		

Note: When recording signal on SONY tape "super 150", set TAPE SELECT switch to NORMAL and on SONY SLH tape, to SPECIAL.

18. Overall Distortion Measurement

Control/Switch Setting:

- TAPE SELECT switch: NORMAL
- TAPE SPEED selector: 7 1/2 ips (19 cm/s)
- MONITOR switch: TAPE
- LINE RECORD
- VOLUME control: See page 16

Procedure:

1. Mode: record

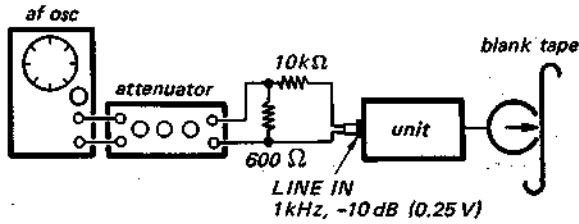

2. Mode: playback

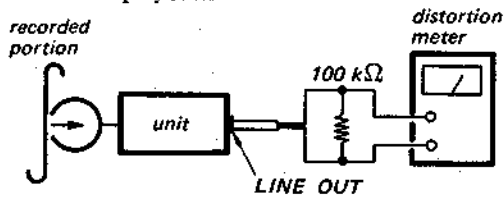

Specification: less than 1.5%

19. Cross-talk Measurement (between channels)

Control/Switch Setting:

- TAPE SELECT switch: NORMAL
- TAPE SPEED selector: 7 1/2 ips (19 cm/s)
- MONITOR switch: TAPE
- LINE RECORD
- VOLUME control: See page 16

Procedure:

1. Mode: stereo record

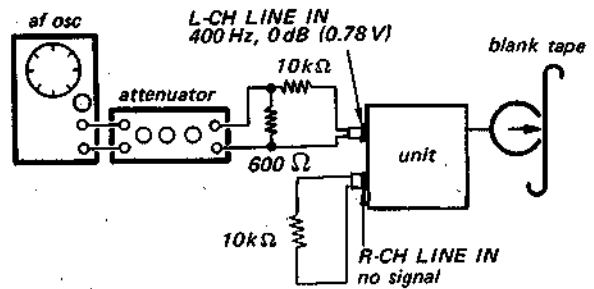

2. Mode: playback

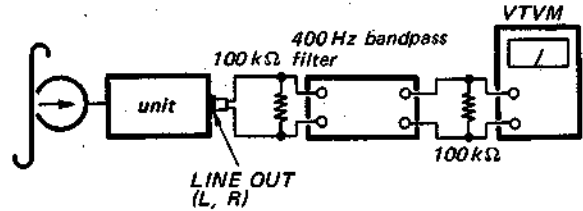

Specification:

Playback	VTVM Reading
L-CH (400 Hz)	level difference:
R-CH (no signal)	greater than 48 dB

**20. Cross-Talk Measurement
(between tracks)**

Control/Switch Setting:

- TAPE SELECT switch: NORMAL
- TAPE SPEED selector: 7 1/2 ips (19 cm/s)
- MONITOR switch: TAPE
- LINE RECORD
- VOLUME control: See page 16

Procedure:

1. Mode: stereo record

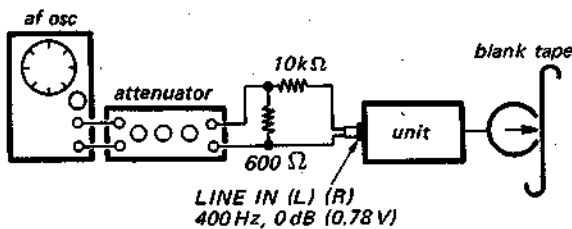

2. Turn the reels over.
3. Mode: playback

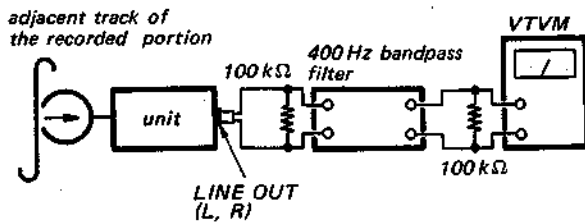

Specification:

Playback	VTVM reading
400 Hz	level difference: greater than 65 dB
adjacent track of the recorded portion	

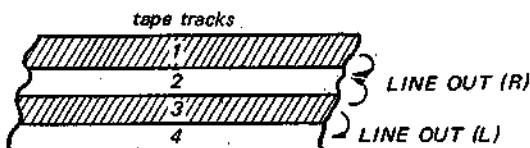

21. Minimum Input Level Check

Control/Switch Setting:

MONITOR switch: SOURCE

Procedure:

A. MICROPHONE Jack Level Check

1. Set LINE RECORD VOLUME to MIN and MIC RECORD VOLUME to MAX position.
2. Supply 1kHz signal into MICROPHONE jack and adjust attenuator to obtain 0 dB (0.78 V) VTVM reading.
3. Be sure that MICROPHONE jack level is less than -72 dB (0.2 mV).

B. LINE IN Jack Level Check

1. Set MIC RECORD VOLUME to MIN and LINE RECORD VOLUME to MAX position.
2. Supply 1 kHz signal into LINE IN jack and adjust attenuator to obtain 0 dB (0.78 V) VTVM reading.
3. Be sure that LINE IN jack level is less than -22 dB (61.5 mV).

Mode: record

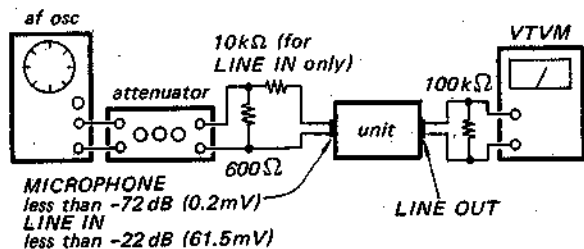

3-3. POWER FREQUENCY ADAPTATION

The motor pulley and tapping of the motor capacitor terminals must be changed, if the line frequency differs from what the recorder is set for.

<p>To change connection of the motor capacitor terminals</p> <p>The motor capacitor is located at the upper side of the drive mechanism. Change the connection of the motor capacitor terminals by soldering as illustrated.</p> <div style="text-align: center;"> </div>	<p>To change motor pulley</p> <p>Remove the top panel as described in DISASSEMBLY on page 6.</p> <ol style="list-style-type: none"> 1. Remove PAUSE adjusting plate by loosening the screw (A). Withdraw PAUSE pull rod. 2. Remove rubber belt from the motor pulley and idler wheel. 3. Remove motor pulley by loosening two screws (B) and (C) which hold motor pulley. 4. Use the supplied motor pulley with same mark and tighten the screws. <div style="text-align: center;"> </div>
--	---

Motor Pulley Part No.			
for 50 Hz		for 60 Hz	
Mark on Motor Pulley	Part No.	Mark on Motor Pulley	Part No.
+2	3-518-067-61	+2	3-518-068-61
+1	3-518-067-51	+1	3-518-068-51
+0.5	3-518-067-41	+0.5	3-518-068-41
0	3-518-067-01	0	3-518-068-01
-0.5	3-518-067-11	-0.5	3-518-068-11
-1	3-518-067-21	-1	3-518-068-21
-2	3-518-067-31	-2	3-518-068-31

SECTION 4
DIAGRAMS

MEMO

4-1. LEVEL DIAGRAMS

Playback

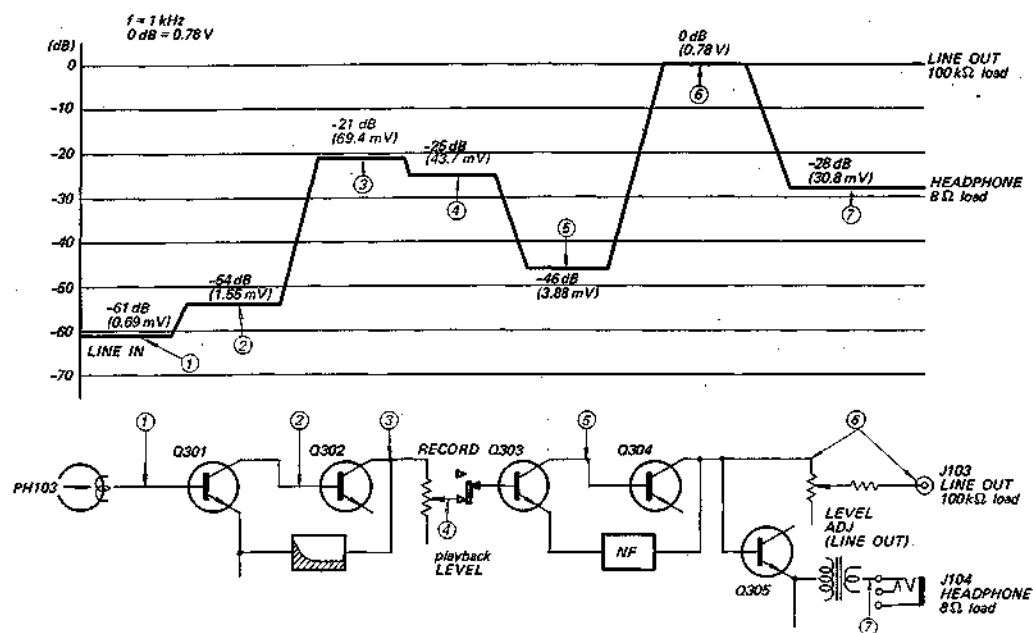

Record

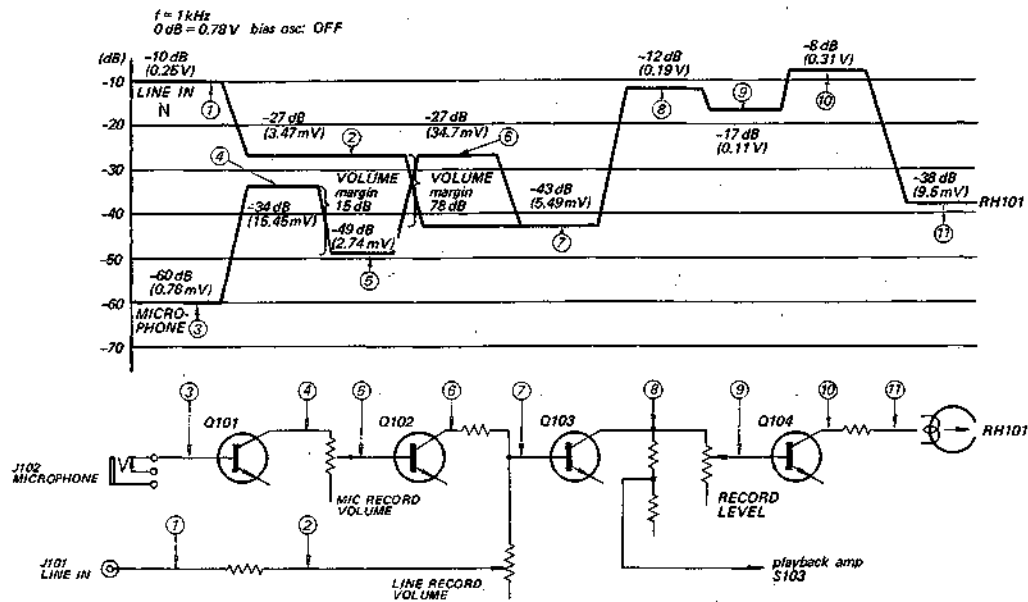

4-2. SCHEMATIC DIAGRAM

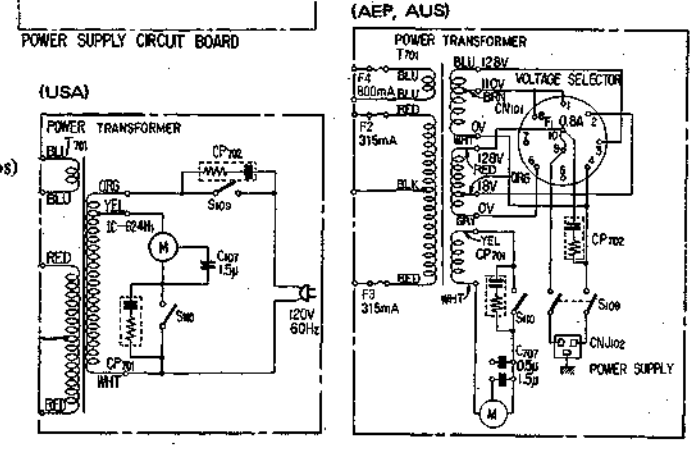
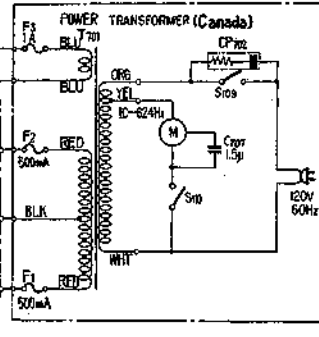
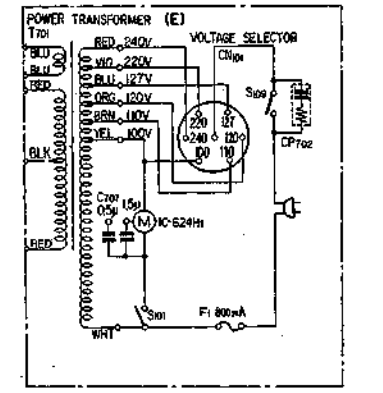
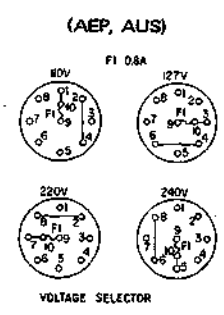
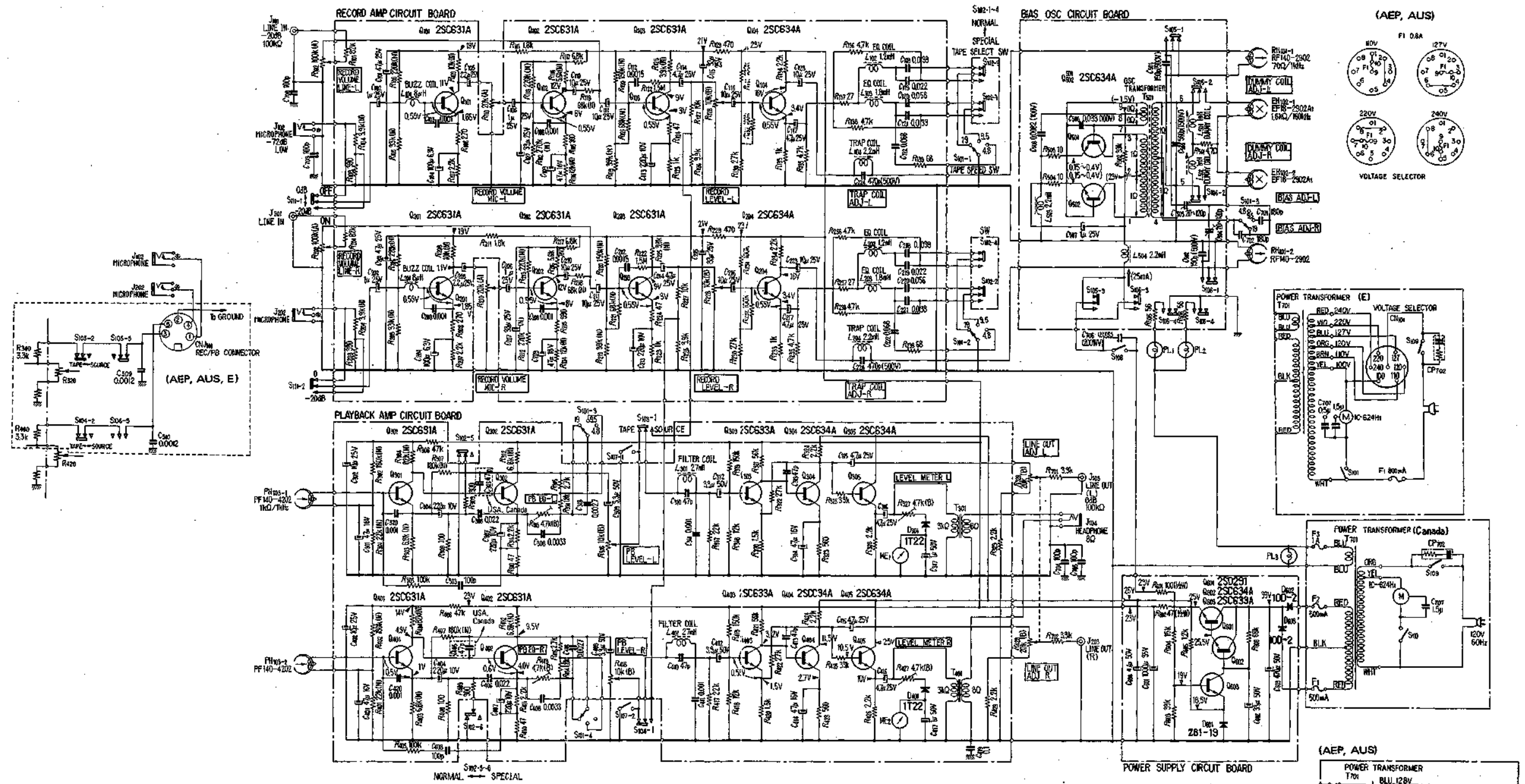

Note:

- All resistors and capacitors are rated in Ω and μF , unless otherwise specified.
- The letter (A), (B) suffixed to rating value of variable or adjustable resistor indicates its characteristics.
- Voltage values shown are measured with a voltmeter (20 k Ω /V) in playback mode. Voltage and current values in () are measured in record mode. Variations may be noted because of normal production tolerances.
- Symbols
 ⏏ : Chassis ground
 (N) : Low noise resistor

5. Switch position

Ref. No.	Description	Position
S101	TAPE SPEED	19 cm/sec (7 1/2 ips)
S102	TAPE SELECT	NORMAL
S103	MONITOR (L-CHANNEL)	TAPE
S104	MONITOR (R-CHANNEL)	TAPE
S105	record/playback (L-channel)	playback
S106	record/playback (R-channel)	playback
S107	muting	OFF
S108	bias osc	OFF
S109	POWER	OFF
S110	auto shut-off	OFF
S111	MIC ATT	OFF

4-3. MOUNTING DIAGRAMS

4-3-1. Tape Select Switch Circuit Board

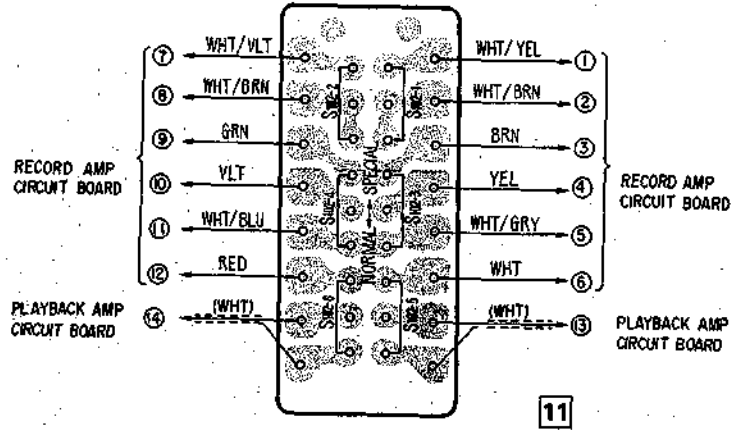

4-3-2. Power Supply Circuit Board

Conductor Side

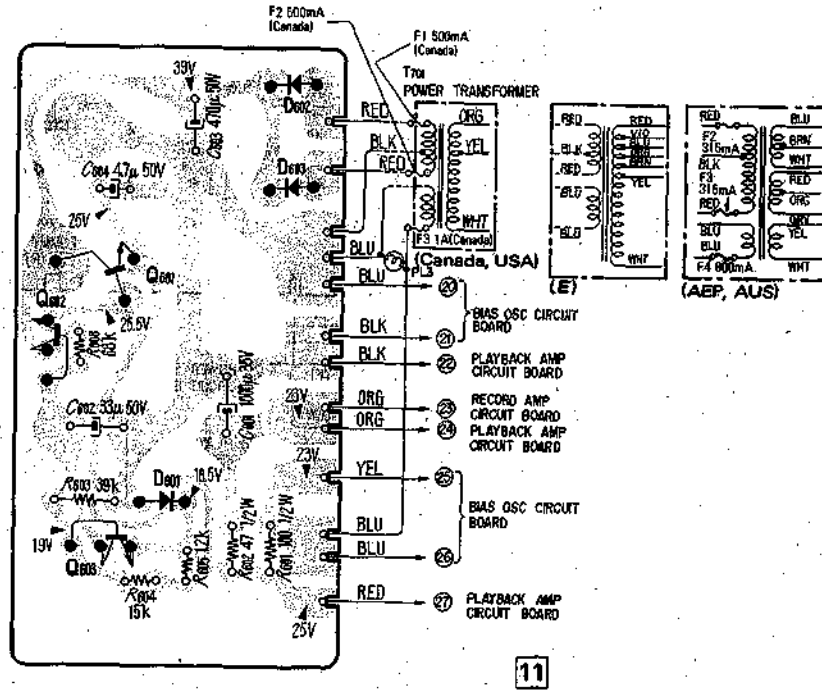

- Q601: 2SD291
- Q602: 2SC634A
- Q603: 2SC633A
- D601: ZB1-19
- D602, 603: 10D-2

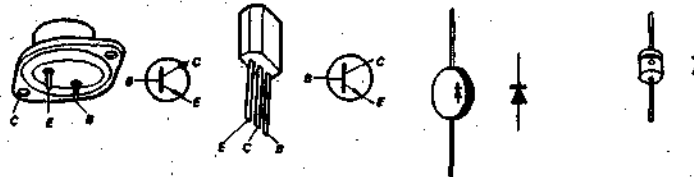

4-3-3. Bias Osc Circuit Board
Conductor Side

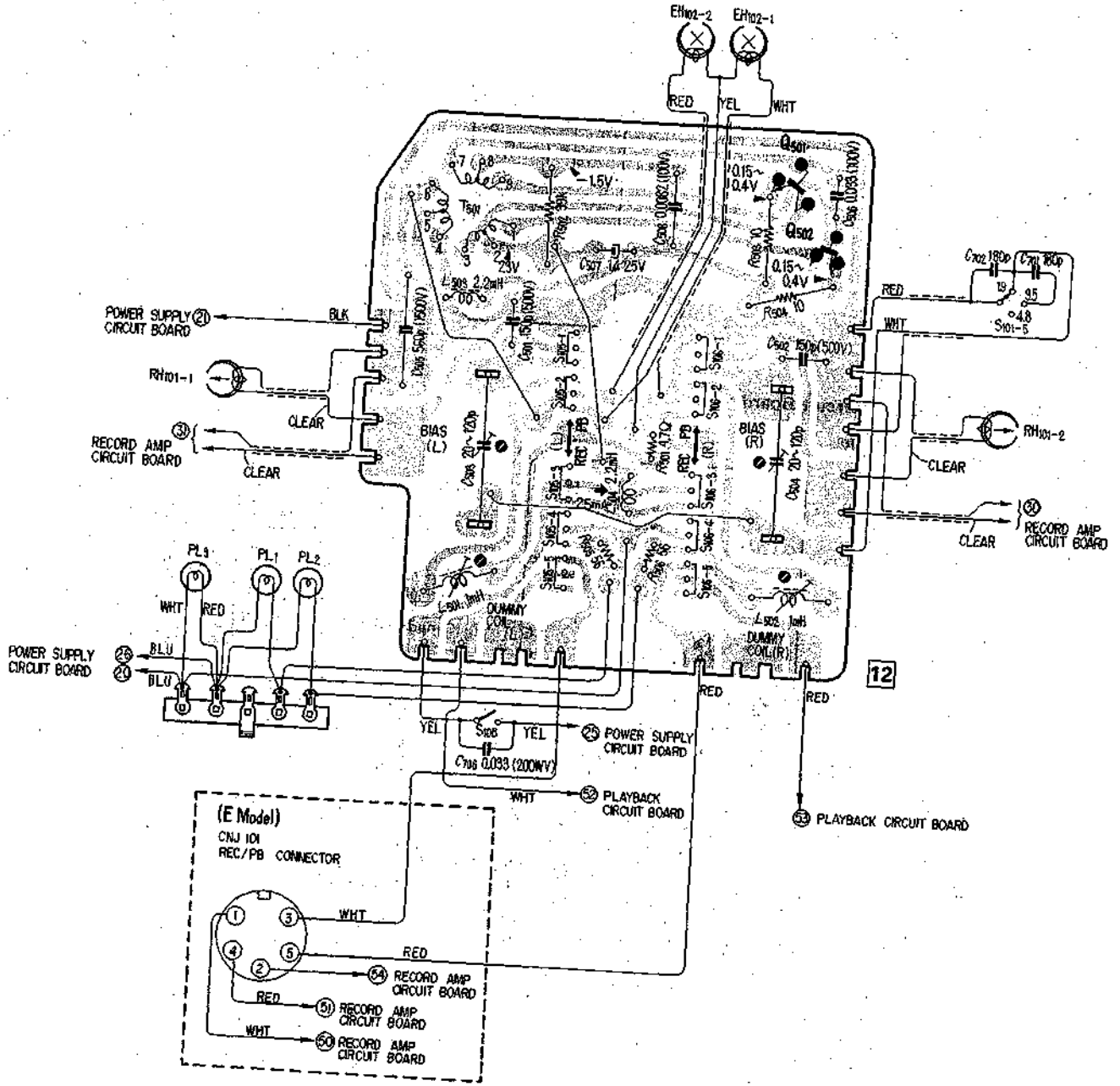

Q501, 502: 2SC634A

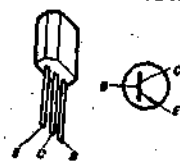

4-3-4. Record Amp Circuit Board
Conductor Side

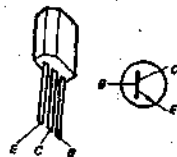
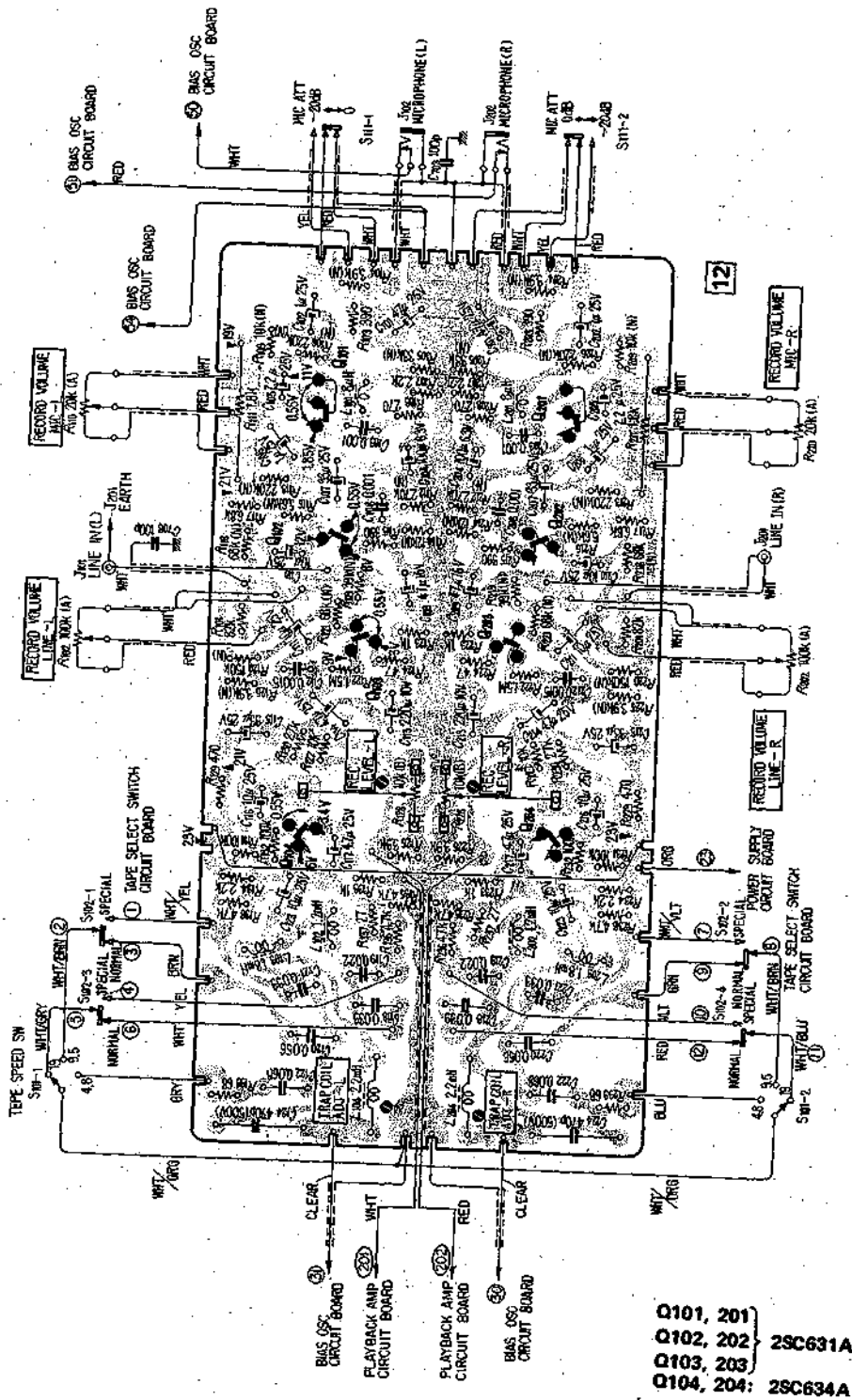

4-3.5. Playback Amp Circuit Board

Conductor Side

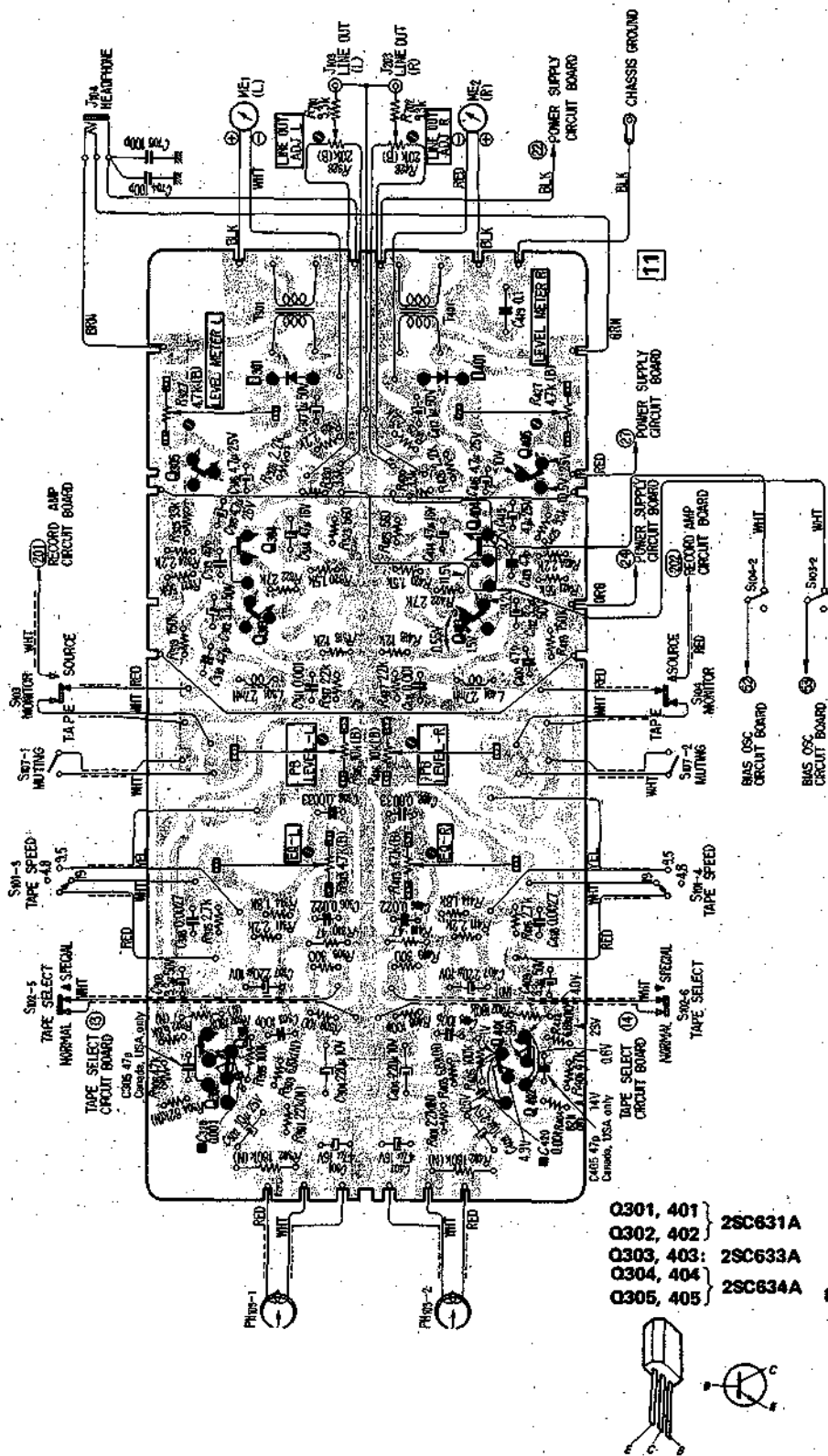

■ : Mounted on the Conductor Side of Playback Amp Circuit Board.

SECTION 5 EXPLODED VIEWS

5-1. CABINET – Top View –

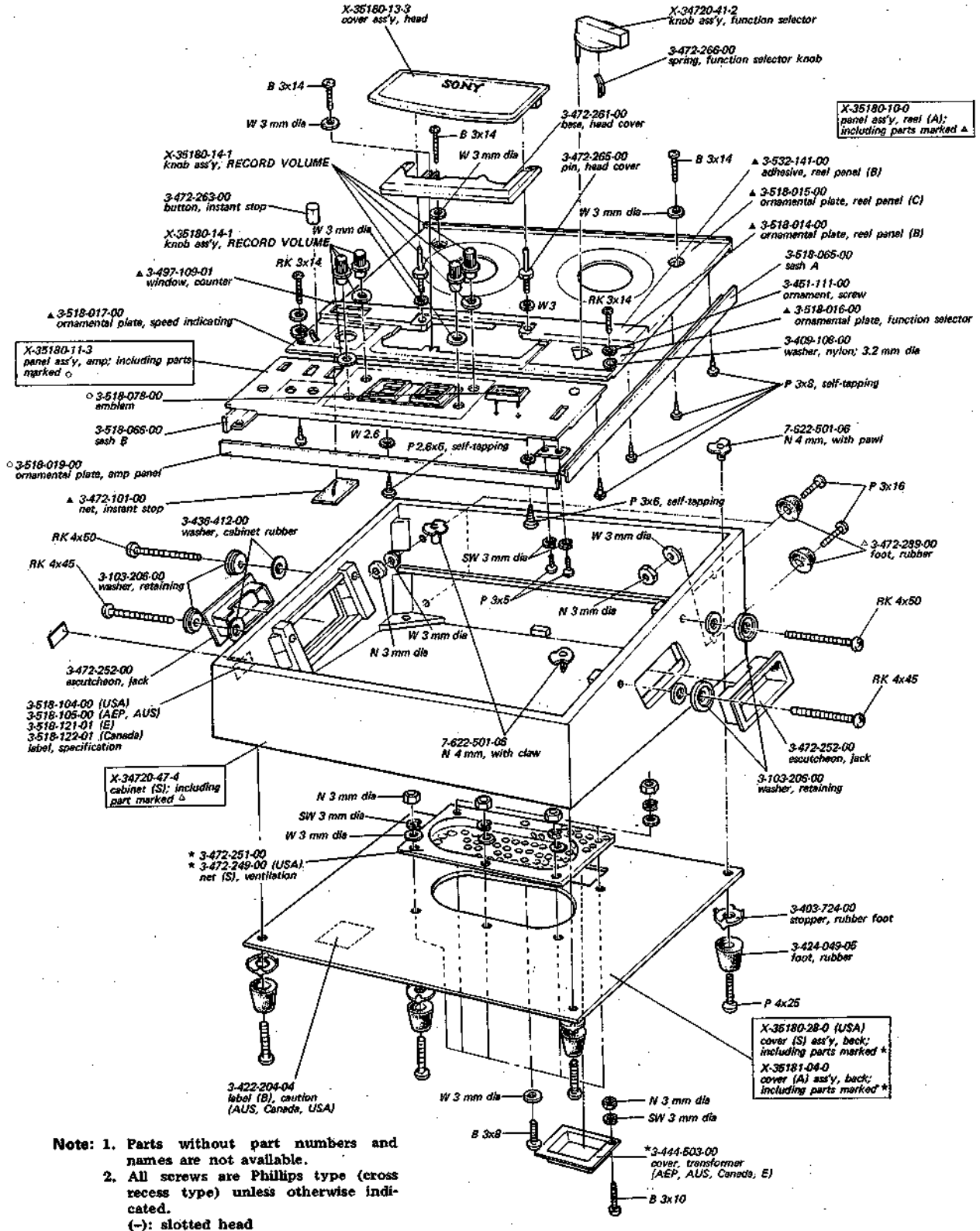

5-2. HEAD DECK – Top View –

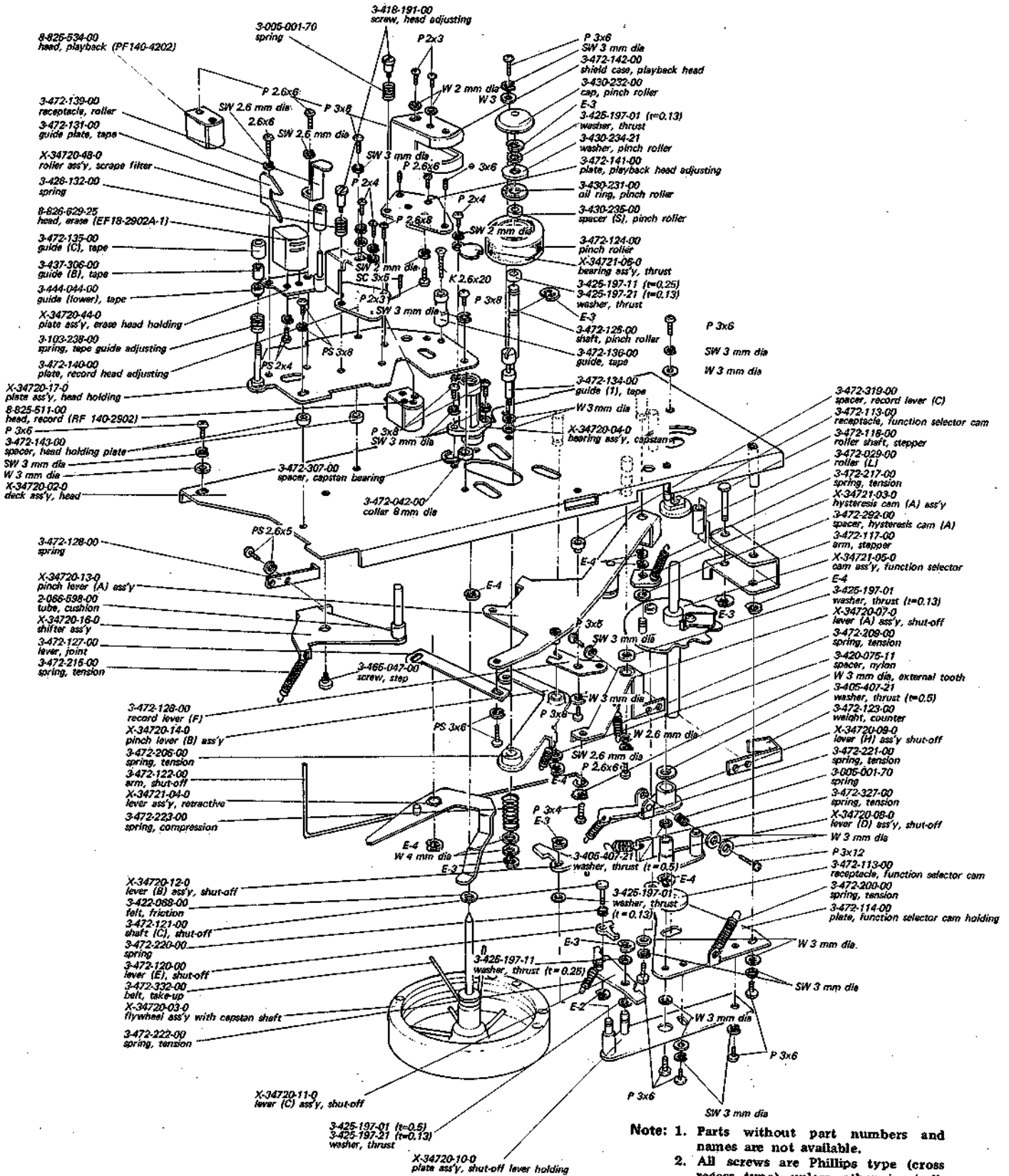

Note: 1. Parts without part numbers and names are not available.
 2. All screws are Phillips type (cross recess type) unless otherwise indicated.
 (-): slotted head

5.4. CHASSIS - Top View -

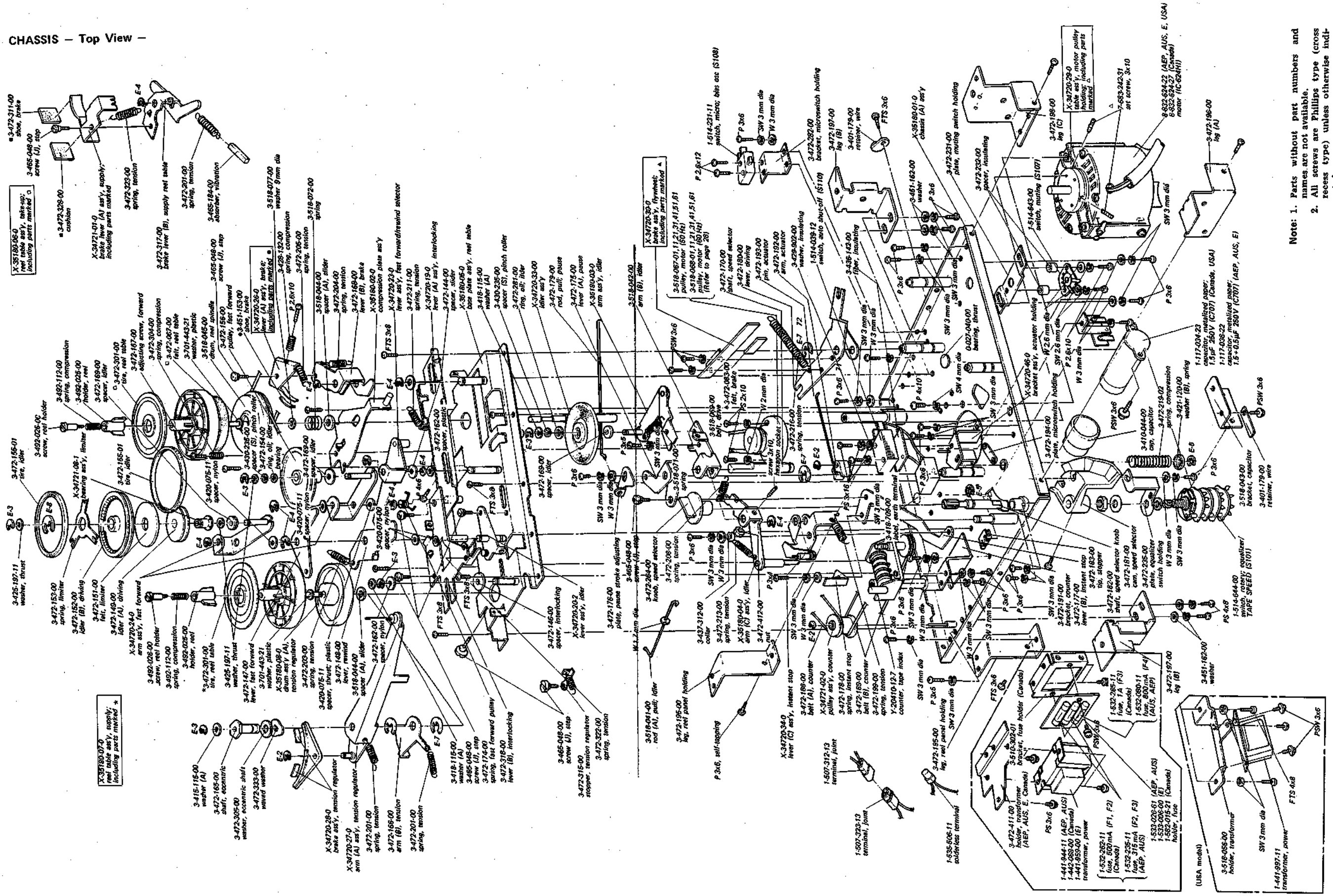

Note: 1. Parts without part numbers and names are not available.
 2. All screws are Phillips type (cross recess type) unless otherwise indicated.
 (-): slotted head

5.5. PACKING

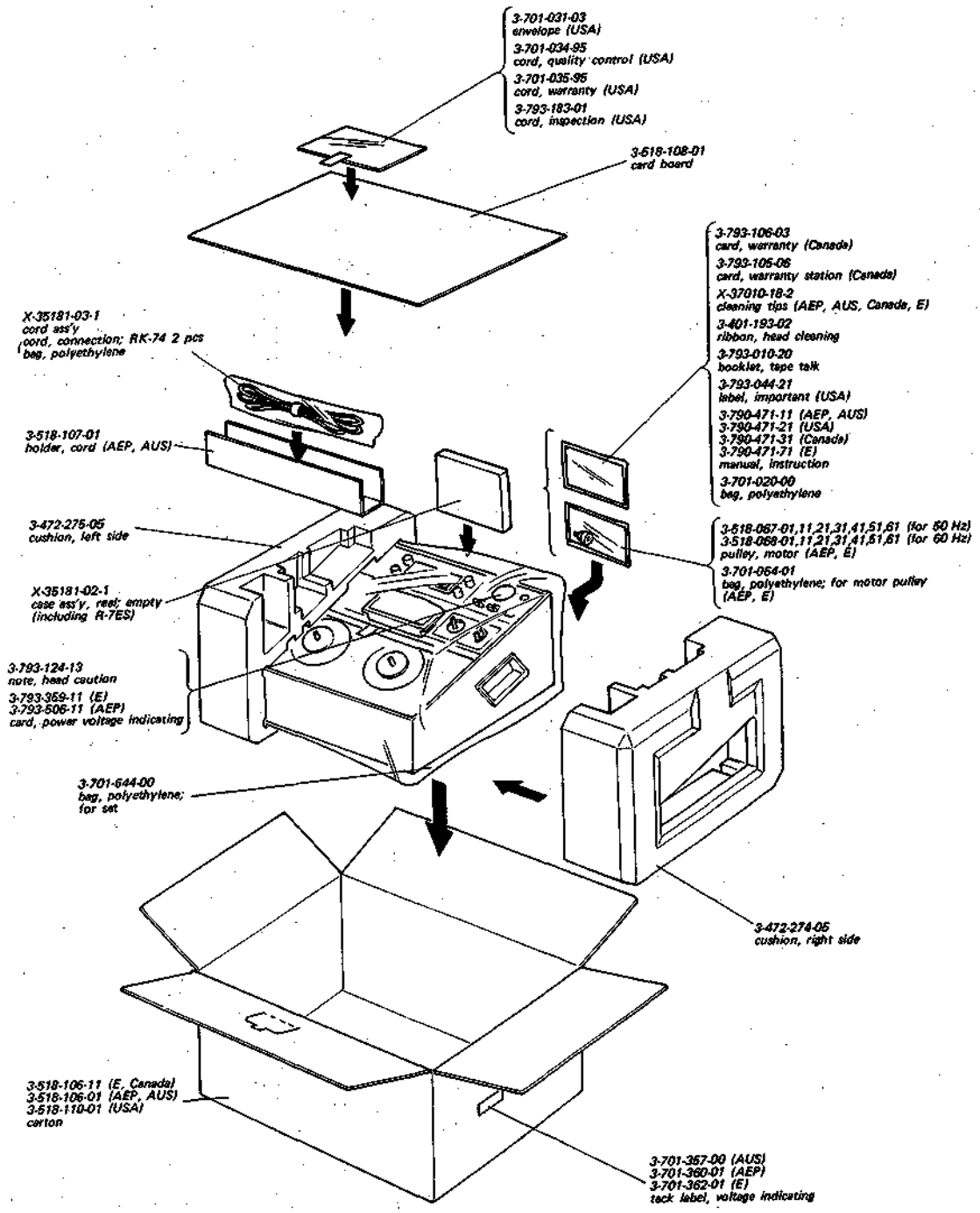

Note: 1. Parts without part numbers and names are not available.
 2. All screws are Phillips type (cross recess type) unless otherwise indicated.
 (-): slotted head

**SECTION 6
ELECTRICAL PARTS LIST**

<u>Ref. No.</u>	<u>Part No.</u>	<u>Description</u>
COMPLETE CIRCUIT BOARDS		
X-35180-51-1		record amp (Canada, USA)
X-35180-52-1		playback amp (Canada, USA)
X-35180-53-1		power supply
X-35180-54-1		bias osc (Canada, USA)
X-35180-55-1		TAPE SELECT switch
X-35181-51-1		record amp (AEP, AUS, E)
X-35181-52-1		playback amp (AEP, AUS, E)
X-35181-53-1		bias osc (AEP, AUS, E)

SEMICONDUCTORS		
Q101, 201	transistor	2SC631A
Q102, 202	transistor	2SC631A
Q103, 203	transistor	2SC631A
Q104, 204	transistor	2SC634A
Q301, 401	transistor	2SC631A
Q302, 402	transistor	2SC631A
Q303, 403	transistor	2SC633A
Q304, 404	transistor	2SC634A
Q305, 405	transistor	2SC634A
Q501	transistor	2SC634A
Q502	transistor	2SC634A
Q601	transistor	2SD291
Q602	transistor	2SC634A
Q603	transistor	2SC633A
D301, 401	diode	1T-22
D601	diode	ZB1-19
D602	diode	10D-2
D603	diode	10D-2

COILS		
L101, 201	1-407-519-11	inductor, micro 8 μ H
L102, 202	1-407-493-21	inductor, micro 1.2 mH
L103, 203	1-407-495-21	inductor, micro 1.8 mH
L104, 204	1-407-286-11	coil, trap 2.2 mH
L301, 401	1-407-593-11	inductor, micro 27 mH
L501	1-407-284-00	coil, dummy 1 mH
L502	1-407-284-00	coil, dummy 1 mH

<u>Ref. No.</u>	<u>Part No.</u>	<u>Description</u>
L503	1-407-198-21	inductor, micro 2.2 mH
L504	1-407-198-21	inductor, micro 2.2 mH

TRANSFORMERS		
T301, 401	1-427-299-00	output
T501	1-433-140-11	bias osc
T701	1-441-997-11	power (USA)
	1-441-944-11	power (AEP, AUS)
	1-441-959-00	power (E)
	1-442-068-00	power (Canada)

CAPACITORS					
All capacitors are microfarads unless otherwise noted. (p = μ F, elect = electrolytic)					
C101, 201	1-121-410-11	47	25V	elect	
C102, 202	1-127-094-11	1	25V	solid aluminum elect	
C103, 203	1-105-821-12	0.001	50V	mylar	
C104, 204	1-121-413-11	100	6.3V	elect	
C105, 205	1-127-095-11	2.2	25V	solid aluminum elect	
C106, 206	1-127-094-11	1	25V	solid aluminum elect	
C107, 207	1-121-404-11	33	25V	elect	
C108, 208	1-105-821-12	0.001	50V	mylar	
C109, 209	1-121-409-11	47	16V	elect	
C110, 210	1-121-398-11	10	25V	elect	
C111, 211	1-121-398-11	10	25V	elect	
C112, 212	1-105-663-12	0.0015	50V	mylar	
C113, 213	1-121-420-11	220	10V	elect	
C114, 214	1-121-395-11	4.7	25V	elect	
C115, 215	1-121-404-11	33	25V	elect	
C116, 216	1-121-398-11	10	25V	elect	
C117, 217	1-121-395-11	4.7	25V	elect	
C118, 218	1-105-520-12	0.039	50V	mylar	
C119, 219	1-105-517-12	0.022	50V	mylar	
C120, 220	1-105-522-12	0.056	50V	mylar	
C121, 221	1-105-519-12	0.033	50V	mylar	
C122, 222	1-105-523-12	0.068	50V	mylar	
C123, 223	1-121-398-11	10	25V	elect	
C124, 224	1-107-016-11	470	50V	silvered mica	
C301, 401	1-121-409-11	47	16V	elect	
C302, 402	1-121-398-11	10	25V	elect	
C303, 403	1-107-131-11	100p	50V	silvered mica	

<u>Ref. No.</u>	<u>Part No.</u>	<u>Description</u>	
C304, 404	1-121-420-11	220	10V elect
C305, 405	1-107-123-11	47p	50V silvered mica (Canada, USA)
C306, 406	1-105-517-12	0.022	50V mylar
C307, 407	1-121-420-11	220	10V elect
C308, 408	1-106-667-12	0.0033	50V mylar
C309, 409	1-121-393-11	3.3	50V elect
C310, 410	1-107-123-11	47p	50V silvered mica
C311, 411	1-105-661-12	0.001	50V mylar
C312, 412	1-121-393-11	3.3	50V elect
C313, 413	1-107-123-11	47p	50V silvered mica
C314, 414	1-121-409-11	47	16V elect
C315, 415	1-121-395-11	4.7	25V elect
C316, 416	1-121-395-11	4.7	25V elect
C317, 417	1-121-391-11	1	50V elect
C318, 418	1-105-666-12	0.0027	50V mylar
C419	1-105-845-12	0.1	50V mylar
C320, 420	1-105-661-12	0.001	50V mylar
C501	1-107-008-11	150p	500V silvered mica
C502	1-107-008-11	150p	500V silvered mica
C503	1-141-069-11	20 ~ 120p	trimmer
C504	1-141-069-11	20 ~ 120p	trimmer
C505	1-107-221-11	560p	1,500V silvered mica
C506	1-105-719-12	0.033	100V mylar
C507	1-127-094-11	1	25V solid aluminum elect
C508	1-105-712-12	0.0082	100V mylar
C509	1-106-060-12	0.0012	100V mylar (AEP, AUS, E)
C510	1-106-060-12	0.0012	100V mylar (AEP, AUS, E)
C601	1-121-388-11	1,000	35V elect
C602	1-121-405-11	33	50V elect
C603	1-121-810-11	470	50V elect
C604	1-121-396-11	4.7	50V elect
C701	1-107-175-11	180p	50V silvered mica
C702	1-107-175-11	180p	50V silvered mica
C703	1-107-131-11	100p	50V silvered mica
C704	1-107-131-11	100p	50V silvered mica
C705	1-107-131-11	100p	50V silvered mica
C706	1-105-759-12	0.033	200V mylar
C707	1-117-034-23	1.5	250V metalized paper (Canada, USA)
	1-117-036-22	1.5+0.5	250V metalized paper (AEP, AUS, E)
C708	1-107-131-11	100p	silvered mica

RESISTORS

All resistors are 1/4W, carbon type and in Ω unless otherwise noted.

R101, 201 1-244-719-11 82k

<u>Ref. No.</u>	<u>Part No.</u>	<u>Description</u>	
R102, 202	1-222-305-11	100k (A)	variable (LINE RECORD VOLUME)
R103, 203	1-242-663-11	390	
R104, 204	1-242-687-09	3.9k	low noise
R105, 205	1-242-709-09	33k	low noise
R106, 206	1-242-729-09	220k	low noise
R107, 207	1-242-681-11	2.2k	
R108, 208	1-242-659-11	270	
R109, 209	1-242-697-09	10k	low noise
R110, 210	1-222-306-11	20k (A)	variable (MIC RECORD VOLUME)
R111, 211	1-244-679-11	1.8k	
R112, 212	1-242-731-09	270k	low noise
R113, 213	1-242-729-09	220k	low noise
R114, 214	1-242-699-09	12k	low noise
R115, 215	1-242-663-11	390	
R116, 216	1-242-691-09	5.6k	low noise
R117, 217	1-242-693-11	6.8k	
R118, 218	1-242-717-09	68k	low noise
R119, 219	1-242-711-09	39k	low noise
R120, 220	1-242-725-09	150k	low noise
R121, 221	1-242-717-09	68k	low noise
R122, 222	1-242-749-11	1.5M	
R123, 223	1-242-673-11	1k	
R124, 224	1-242-641-11	47	
R125, 225	1-242-687-09	3.9k	low noise
R126, 226	1-242-687-11	3.9k	
R127, 227	1-242-697-11	10k	
R128, 228	1-222-774-11	10k (B)	adjustable (record level adj)
R129, 229	1-242-665-11	470	
R130, 230	1-242-707-11	27k	
R131, 231	1-242-721-11	100k	
R132, 232	1-242-721-11	100k	
R133, 233	1-242-673-11	1k	
R134, 234	1-242-681-11	2.2k	
R135, 235	1-242-689-11	4.7k	
R136, 236	1-242-689-11	4.7k	
R137, 237	1-242-635-11	27	
R138, 238	1-242-689-11	4.7k	
R139, 239	1-242-645-11	68	
R301, 401	1-242-705-09	22k	low noise
R302, 402	1-242-727-09	180k	low noise
R303, 403	1-242-693-09	68k	low noise
R304, 404	1-242-719-09	82k	low noise
R305, 405	1-242-721-11	100k	
R306, 406	1-242-713-11	47k	
R307, 407	1-242-727-09	180k	low noise
R308, 408	1-242-649-11	100	
R309, 409	1-242-660-11	300	
R310, 410	1-242-641-11	47	
R311, 411	1-242-681-11	2.2k	
R312, 412	1-242-693-09	6.8k	low noise

<u>Ref. No.</u>	<u>Part No.</u>	<u>Description</u>
R313, 413	1-222-773-11	4.7 k (B) adjustable (PB EQ adj)
R314, 414	1-242-679-11	1.8 k
R315, 415	1-242-683-11	2.7 k
R316, 416	1-222-774-11	10k (B) adjustable (PB EQ adj)
R317, 417	1-242-705-11	22k
R318, 418	1-242-699-11	12k
R319, 419	1-242-725-11	150k
R320, 420	1-242-677-11	1.5 k
R321, 421	1-242-715-11	56 k
R322, 422	1-242-707-11	27 k
R323, 423	1-242-667-11	560
R324, 424	1-242-681-11	2.2 k
R325, 425	1-242-709-11	33 k
R326, 426	1-242-681-11	2.2 k
R327, 427	1-222-773-11	4.7k (B) adjustable (level meter adj)
R328, 428	1-222-637-11	20k (B) variable (LEVEL ADJUST)
R329, 429	1-242-681-11	2.2 k
R340, 440	1-242-685-11	3.3k (AEP, AUS, E)
R501	1-242-617-11	4.7
R502	1-244-711-11	39k
R503	1-244-625-11	10
R504	1-244-625-11	10
R505	1-242-643-11	56
R506	1-242-643-11	56
R601	1-202-549-31	100 (%) composition
R602	1-202-541-31	47 (%) composition
R603	1-242-711-11	39k
R604	1-242-701-11	15k
R605	1-242-675-11	1.2k
R606	1-242-717-11	68k
R701	1-244-685-11	3.3k
R702	1-244-685-11	3.3k

SWITCHES

S101	1-514-644-00	rotary, equalizer; TAPE SPEED
S102	1-514-985-00	lever slide, TAPE SELECT
S103	1-514-640-00	lever slide, MONITOR(L-CHANNEL)
S104	1-514-640-00	lever slide, MONITOR(R-CHANNEL)
S105	1-514-861-22	slide, record/playback (L-CH)
S106	1-514-861-22	slide, record/playback (R-CH)
S107	1-514-643-00	rotary, muting

<u>Ref. No.</u>	<u>Part No.</u>	<u>Description</u>
S108	1-514-231-11	micro, bias osc
S109	1-514-655-31	seesaw, POWER (E)
	1-514-472-21	seesaw, POWER (AEP, AUS)
	1-514-655-71	seesaw, POWER (Canada, USA)
S110	1-514-039-12	micro, auto shut-off
S111	1-514-641-00	lever slide, MIC ATT

JACKS

J101, 201	1-507-142-21	2-P phono, LINE IN
J102, 202	1-507-281-00	mini, MICROPHONE
J103, 203	1-507-142-21	2-P phono, LINE OUT
J104	1-507-282-00	binaural, HEADPHONE
CNJ101	1-509-359-11	connector, REC/PB (AEP, AUS, E)
CNJ102	1-509-445-11	connector 3-P, AC IN (AEP, AUS)
CN101	1-509-427-11	socket, power voltage selector (E)
	1-509-482-11	socket, power voltage selector (AEP, AUS)

MISCELLANEOUS

M	8-832-624-22	motor, IC-624H1 (AEP, AUS, E, USA)
	8-832-624-27	motor, IC-624H1 (Canada)
CP701, CP702	1-101-534-12	encapsulated components, 0.1 μ F + 120 Ω (AEP, AUS, E)
	1-101-534-31	encapsulated components, 0.1 μ F + 120 Ω (Canada, USA)
RH101	8-825-511-00	head, record (RF140-2902)
PH103	8-825-534-00	head, playback (PF140-4202)
EH102	8-826-629-25	head, erase (EF18-2902A1)
PL1, 2	1-518-153-31	lamp, 5V/60 mA
PL3	1-518-070-00	lamp, 8V/0.3A
	1-533-051-15	holder, lamp
ME1, 2	1-520-114-12	meter, level
F1	1-532-096-00	fuse, 800mA (E)
	1-532-080-11	fuse, 800mA (AEP, AUS)
F1, 2	1-532-262-11	fuse, 500mA (Canada)
F2	1-532-235-11	fuse, 315mA (AEP, AUS)
F3	1-532-235-11	fuse, 315mA (AEP, AUS)
	1-532-265-11	fuse, 1A (Canada)
F4	1-532-080-11	fuse, 800mA (AEP, AUS)
	1-533-006-00	holder, fuse (E)
	1-533-026-61	holder, fuse (AEP, AUS)
	1-582-015-21	holder, fuse (Canada)
	1-534-487-22	cord, ac power (E)
	1-534-538-21	cord, ac power (Canada, USA)
	1-535-506-11	solderless terminal
	1-536-395-11	terminal strip, 1-L-1 (C type)
	1-536-398-11	terminal strip, 2-L-2 (C type)
	1-506-312-13	terminal, joint
	1-507-323-13	terminal, joint

SECTION 7 HARDWARE

<u>Part No.</u>	<u>Description</u>	<u>Part No.</u>	<u>Description</u>
SCREWS			
7-621-259-42	P 2.6 x 6	7-685-145-21	P 3 x 6, self-tapping
7-621-259-52	P 2.6 x 8	7-685-146-21	P 3 x 8, self-tapping
7-621-259-62	P 2.6 x 10	7-685-549-01	P 3 x 16
7-621-259-72	P 2.6 x 12	WASHERS	
7-621-560-52	K 2.6 x 22	7-623-105-12	2 mm dia
7-621-711-35	B 2.6 x 6	7-623-107-02	2.6 mm dia (small)
7-621-771-38	B 2.6 x 8	7-623-107-22	2.6 mm dia
7-628-145-01	P 3 x 4	7-623-108-02	3 mm dia (small)
7-628-147-01	P 3 x 6	7-623-108-12	3 mm dia (nickel plated)
7-628-148-01	P 3 x 8	7-623-108-18	3 mm dia (chrome plated)
7-628-149-01	P 3 x 10	7-623-108-20	3 mm dia
7-628-150-01	P 3 x 12	7-623-110-02	4 mm dia (small)
7-628-160-01	P 3 x 6	7-623-110-12	4 mm dia
7-628-161-01	P 4 x 8	7-623-113-12	6 mm dia
7-628-547-13	B 3 x 6	7-623-208-22	3 mm dia, spring
7-628-548-13	B 3 x 8	7-623-408-05	3 mm dia, external tooth
7-682-549-13	B 3 x 10	NUTS	
7-682-550-14	B 3 x 12	7-622-108-02	3 mm dia
7-682-551-15	B 3 x 4	7-622-501-06	4 mm dia
7-682-562-13	B 4 x 10	RETAINING RINGS	
7-682-571-14	B 4 x 45	7-624-104-01	E-2
7-682-624-00	PS 2 x 4	7-624-106-01	E-3
7-682-627-00	PS 2 x 8	7-624-108-01	E-4
7-682-633-00	PS 2.6 x 4	7-624-109-01	E-5
7-682-635-00	PS 2.6 x 6	7-624-110-01	E-6
7-682-637-00	PS 2.6 x 10	7-624-111-01	E-7
7-682-646-00	PS 3 x 5	7-624-112-01	E-8
7-682-647-00	PS 3 x 6		
7-682-648-00	PS 3 x 8		
7-682-652-00	PS 3 x 16		
7-682-660-00	PS 4 x 6		
7-682-661-00	PS 4 x 8		
7-683-140-01	⊖ SC 3 x 6, flat point		
7-683-242-31	SC 3 x 10		

Note: All screws are Phillips type (cross recess type) unless otherwise indicated.
(-): slotted head

- Hardware Nomenclature -

<p>P - Pan Head Screw </p> <p>PS - Pan Head Screw with Spring Washer </p> <p>K - Flat Countersunk Head Screw </p> <p>B - Binding Head Screw </p> <p>RK - Oval Countersunk Head Screw </p> <p>T - Truss Head Screw </p> <p>R - Round Head Screw </p> <p>F - Flat Fillister Head Screw </p>	<p>SC - Set Screw </p> <p>E - Retaining Ring (E Washer) </p> <p style="text-align: center;">W - Washer SW - Spring Washer LW - Lock Washer N - Nut</p> <p style="text-align: center;">- Example -</p> <div style="text-align: center;"> </div>
---	--

TC-377

Sony Corporation
© 1973

5D0805-5

9-954-179-01

— 48 —

Printed by: Schaltungsdienst Lange, Berlin (GERMANY)