

TC-270

AEP Model



STEREO TAPECORDER

SPECIFICATIONS

Power Requirements: AC 50/60 Hz, 110V, 127V, 220V,
240V 55W

Track System: Four-track stereo and mono

Reel Size: 7" (18 cm) maximum

Tape Speed: 7½ ips, 3¾ ips and 1⅞ ips
(19 cm/s, 9.5 cm/s and 4.8 cm/s)

Frequency Response:

| | NAB | DIN |
|---------------------------------------|--------------|--------------|
| 30~18,000 Hz, at 7½ ips (19 cm/s) | 30~18,000 Hz | 30~16,000 Hz |
| 30~13,000 Hz, at 3¾ ips (9.5 cm/s) | 30~13,000 Hz | 40~12,500 Hz |
| 30~7,000 Hz, at 1⅞ ips (4.8 cm/s) | 30~7,000 Hz | |

Signal-to-Noise Ratio: 50 dB or more

Wow and Flutter:

| | NAB | DIN |
|----------------------|-------|-------|
| at 7½ ips (19 cm/s) | 0.12% | 0.18% |
| at 3¾ ips (9.5 cm/s) | 0.15% | 0.25% |
| at 1⅞ ips (4.8 cm/s) | 0.2% | |

Frequency: Approx. 85 kHz

Power Output: 5W maximum per channel

Inputs: MIC
Input impedance: low impedance
Maximum sensitivity: 0.19 mV (-72 dB)
REC/PB connector
Input impedance: 3.9 k ohms
Input level: 17.4 mV (-33 dB)

Outputs: LINE OUTputs
Load impedance: more than 10 k ohms
Output level: -5 dB (0.43V)
SPEAKER outputs
Load impedance: 8Ω
REC/PB connector
Output impedance: 80 ohms
Output level: 0 dB (0.775V)
Headphone output
Load impedance: 8Ω

Semiconductors: 18 transistors and 4 diodes

Dimensions: 20¹³/₁₆" (W) x 10³/₁₆" (H) x 15¹/₄" (D)
(513 x 260 x 387 mm)

Weight: 36 lb 6 oz (16.5 kg)

SONY®

SERVICE MANUAL

TABLE OF CONTENTS

| <u>Section</u> | <u>Title</u> | <u>Page</u> |
|----------------|--|-------------|
| 1. | OUTLINE | |
| | 1-1. General Description | 3 |
| | 1-2. Block Diagram | 5 |
| | 1-3. Major Parts Location | 6 |
| 2. | DISASSEMBLY | |
| | 2-1. Reel Panel Removal | 8 |
| 3. | ADJUSTMENT PROCEDURES | |
| | 3-1. Mechanical Adjustment | 9 |
| | 3-2. Electrical Adjustments/Measurements | 12 |
| 4. | DIAGRAMS | |
| | 4-1. Level Diagrams | 21 |
| | 4-2. Schematic Diagram | 23 |
| | 4-3. Mounting Diagram | 25 |
| 5. | EXPLODED VIEWS | |
| | 5-1. Cabinet - top view - | 27 |
| | 5-2. Speaker | 28 |
| | 5-3. Front Chassis | 29 |
| | 5-4. Head Deck - upper - | 30 |
| | 5-5. Control Chassis | 31 |
| | 5-6. Chassis - upper - | 33 |
| | 5-7. Head Deck - lower - | 35 |
| | 5-8. Chassis - lower - | 36 |
| | 5-9. Packing | 37 |
| 6. | ELECTRICAL PARTS LIST | 38 |
| 7. | HARDWARE | 40 |

When ordering replacement parts, you should use PART NUMBER listed on the Parts Lists or shown in the EXPLODED VIEW. The reference number should not be used for ordering purposes.

SECTION 1 OUTLINE

1-1. GENERAL DESCRIPTION

The SONY model TC-270 is a 4-track 2-channel stereo-phantic and monaural tape recorder. The special circuit is equipped as follows:

- * S102, S202 (Playback Mode Switch)
(Mode switch is disconnected in recording mode.)

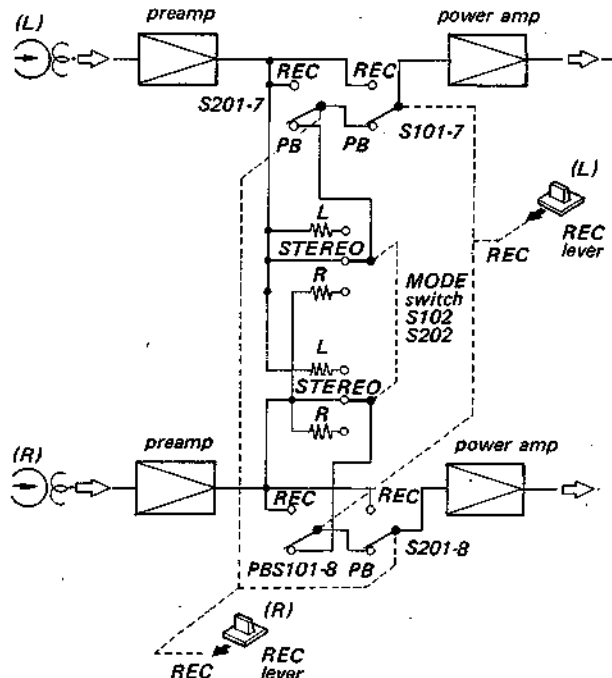

In the monaural playback mode, power amplifiers of both channels are connected in parallel to increase output power.

- * S201-4, S101-5 (TONE Defeat Switch)

TONE controls are worked when both channels are in playback mode and disconnected when one channel is in record mode.

When one channel is in record mode, the other playback channel picks up a leakage of recording bias and recording signals. To prevent such a high frequency leakage from boosting, S201-4 or S101-5 short-circuits TONE control.

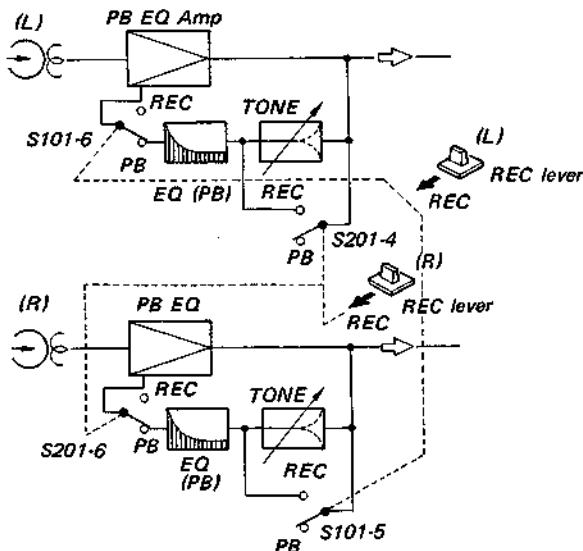

*** S101-3, S201-3**

S101-3 or S201-3, one section of record/playback switch, grounds preamplifier output until the other section is completely changed over to avoid switching click noise.

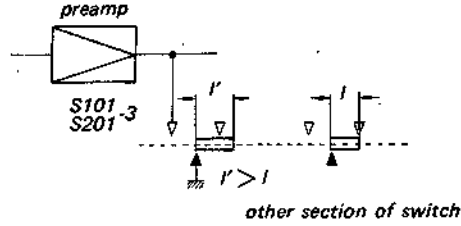

Note:

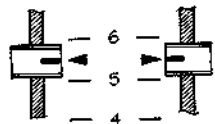
| | Electrical Mid Position | Remarks |
|----------------|---|-----------------------------------|
| TONE control |  ▼ on the panel | flat frequency response |
| VOLUME control |  ▼ on the panel | -5 dB (0.44V) at LINE OUT jack |

1-2. BLOCK DIAGRAM

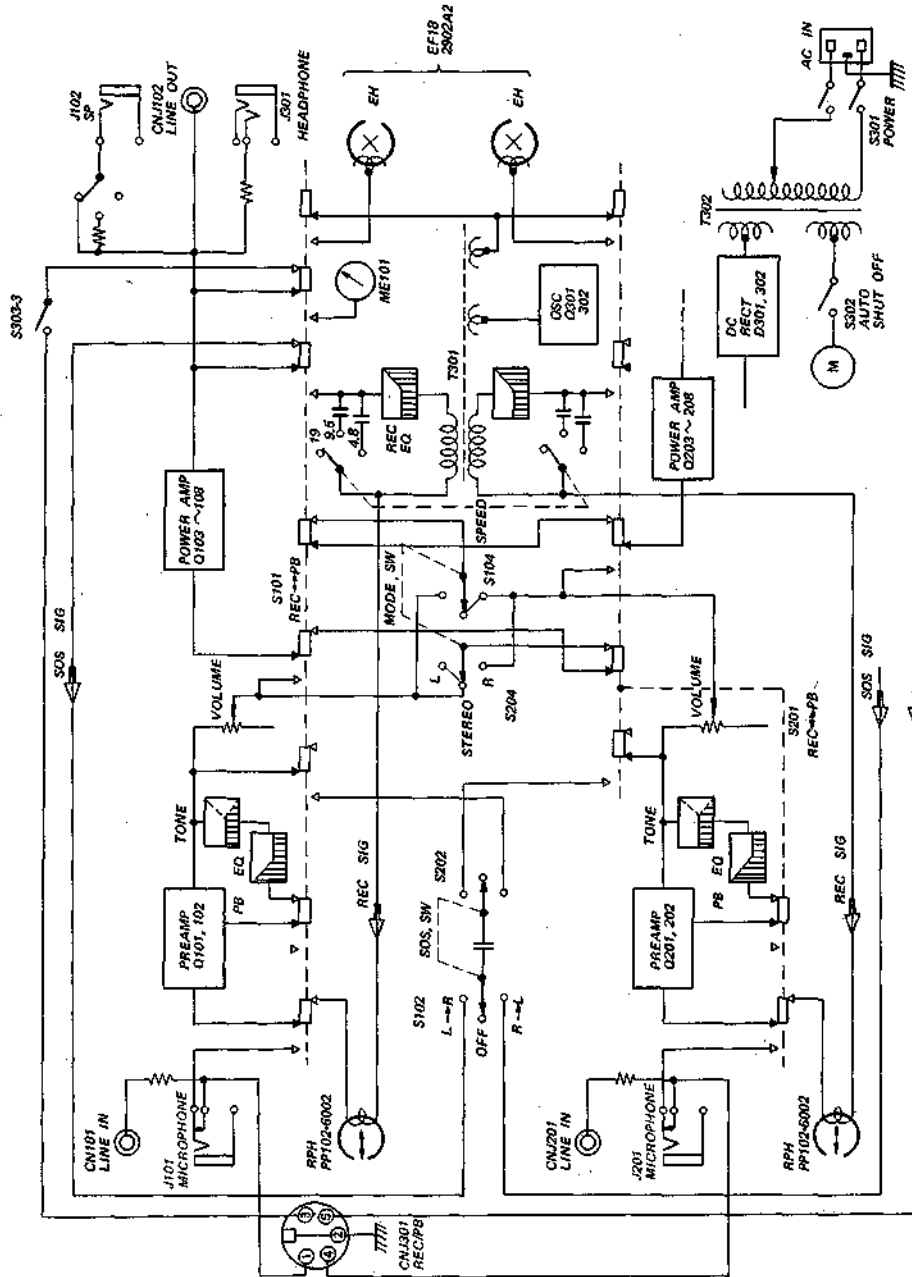

1-3. MAJOR PARTS LOCATION

Front Panel

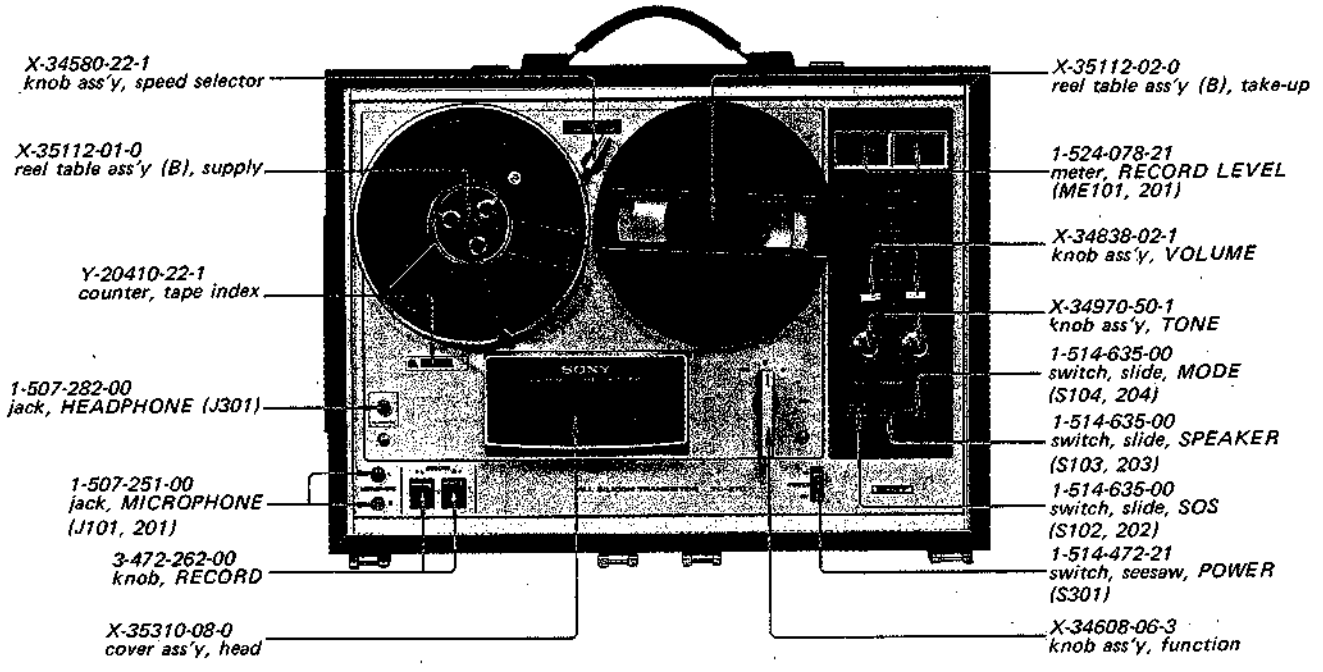

Chassis Front

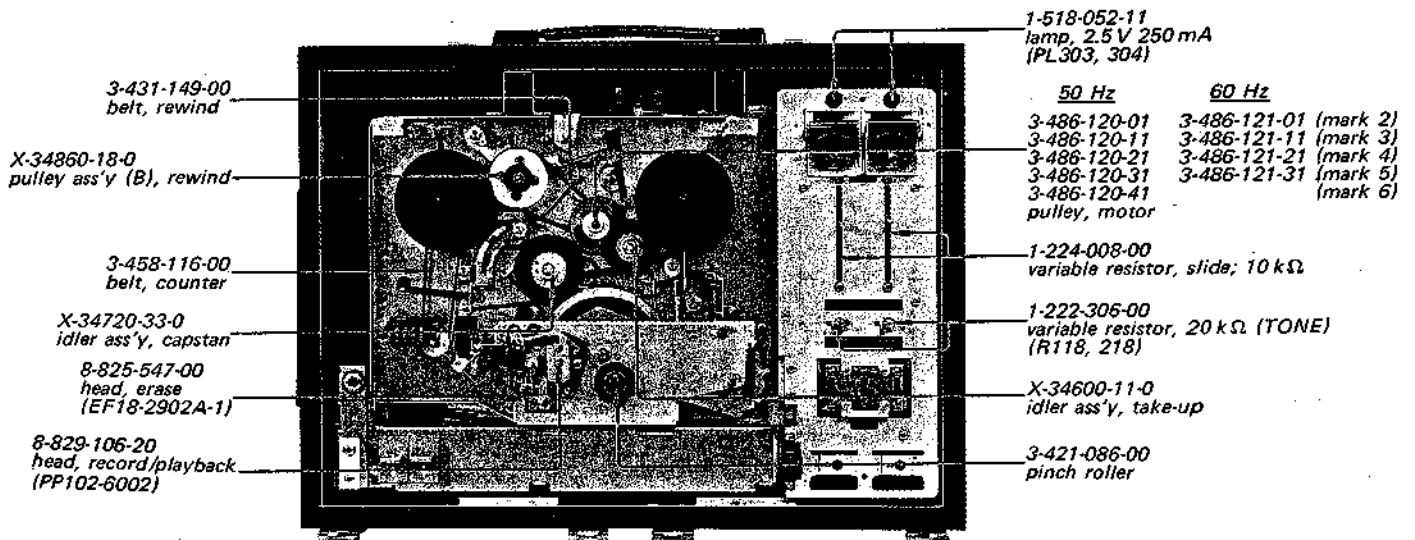

Side Panel

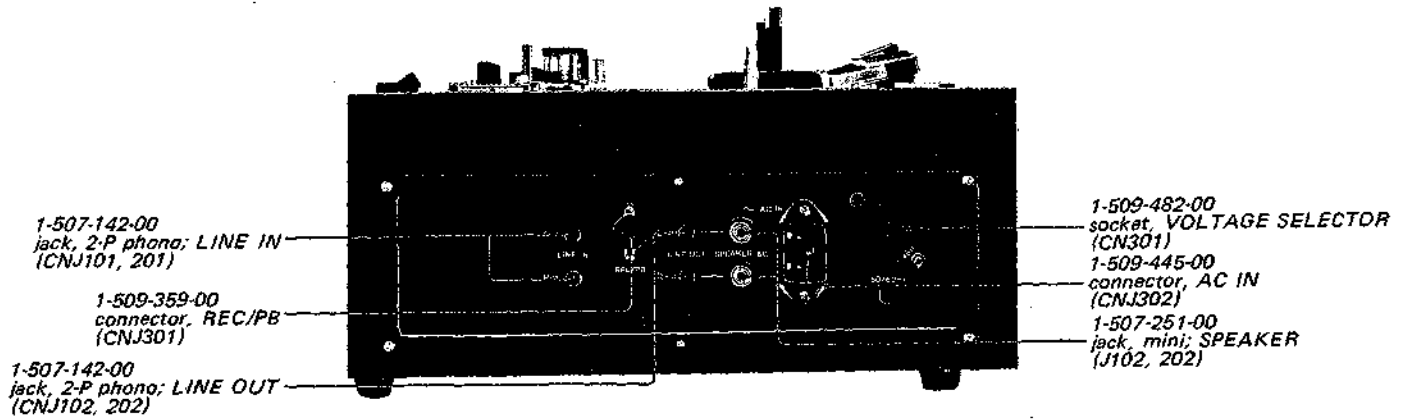

Chassis Bottom

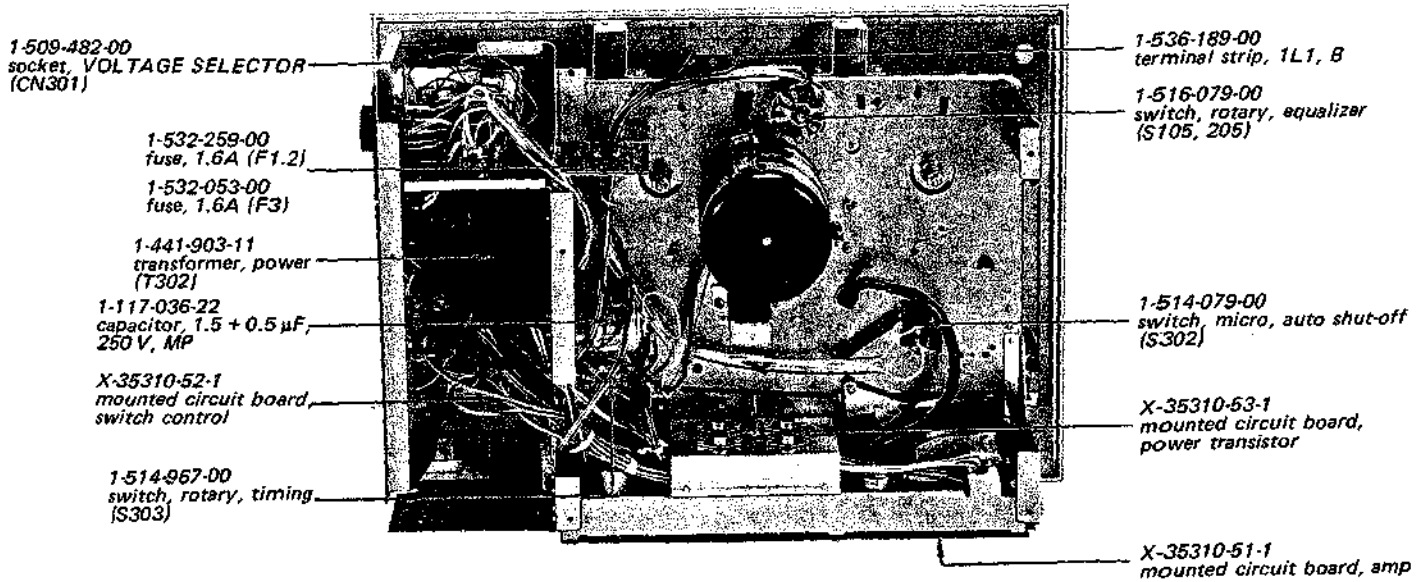

SECTION 2 DISASSEMBLY

2-1. REEL PANEL REMOVAL

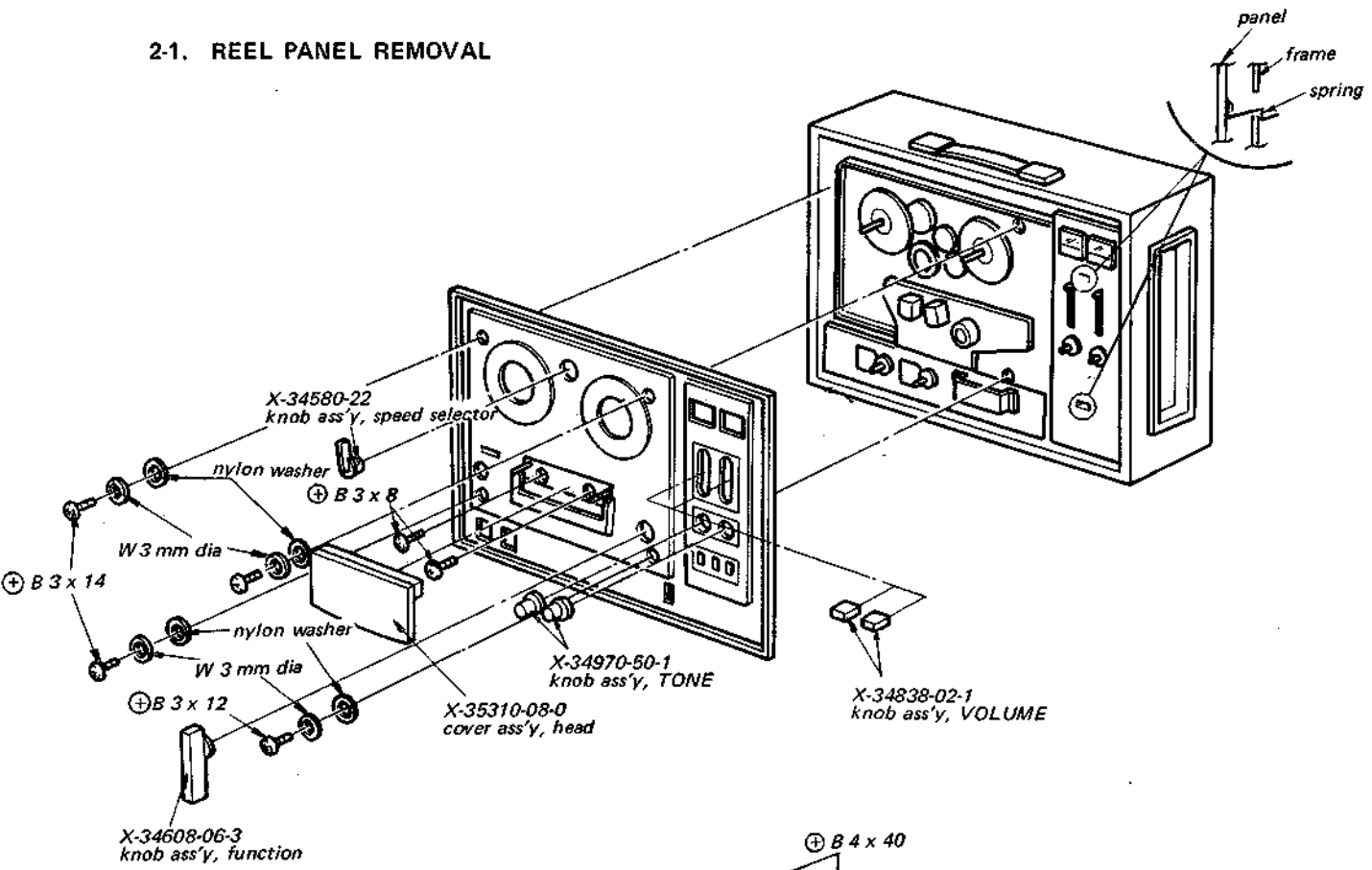

2-2. CABINET REMOVAL

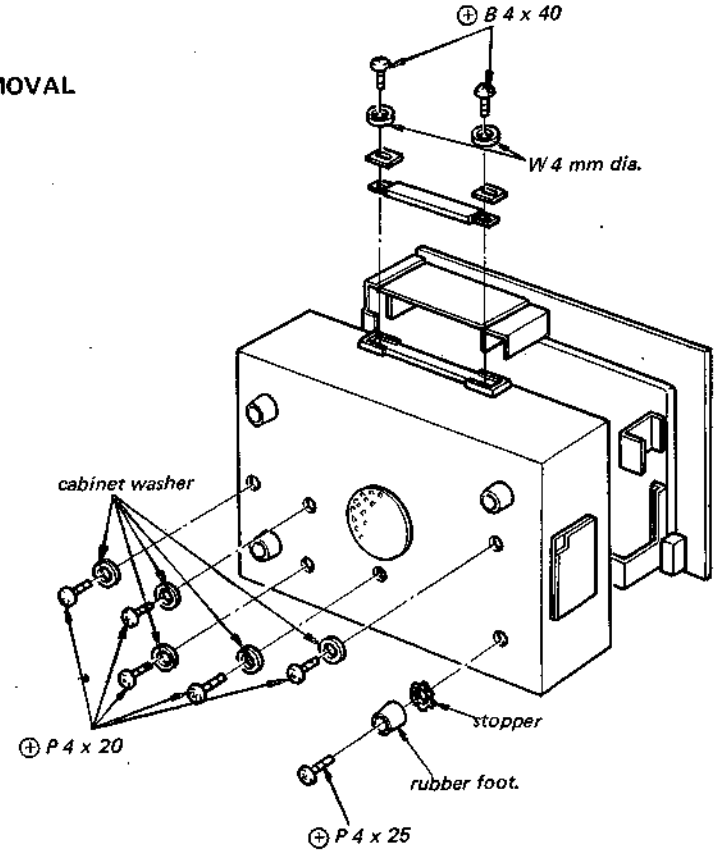

SECTION 3
ADJUSTMENT PROCEDURES

3-1. MECHANICAL ADJUSTMENTS

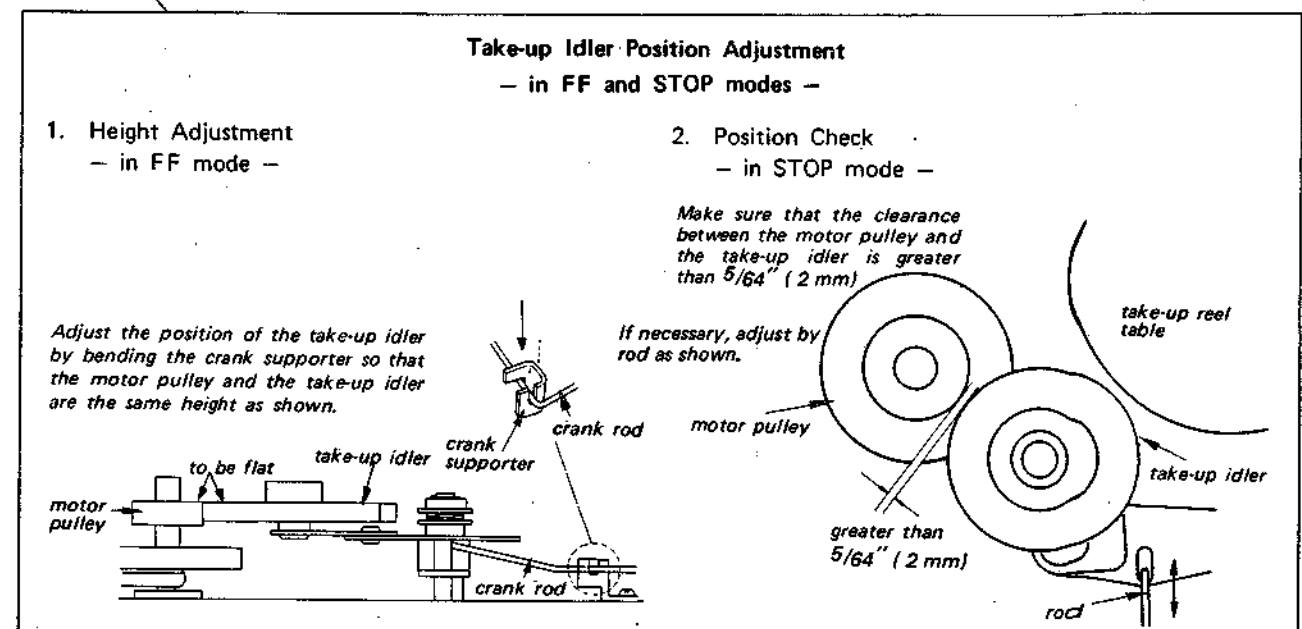
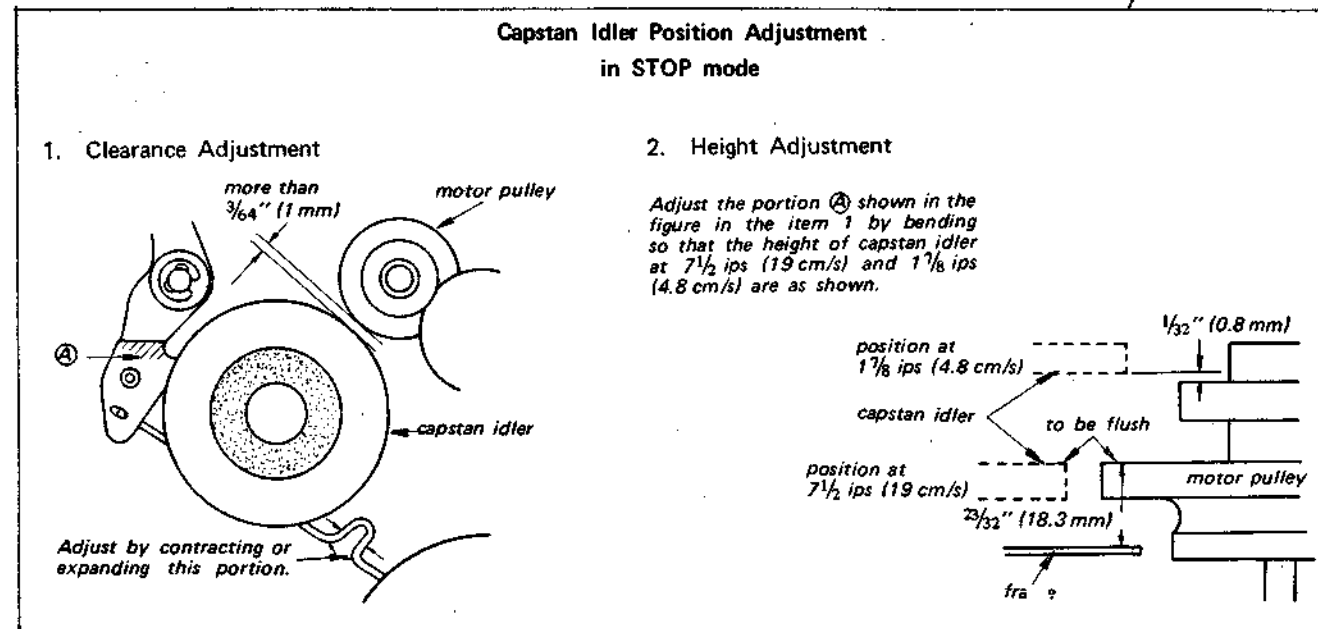
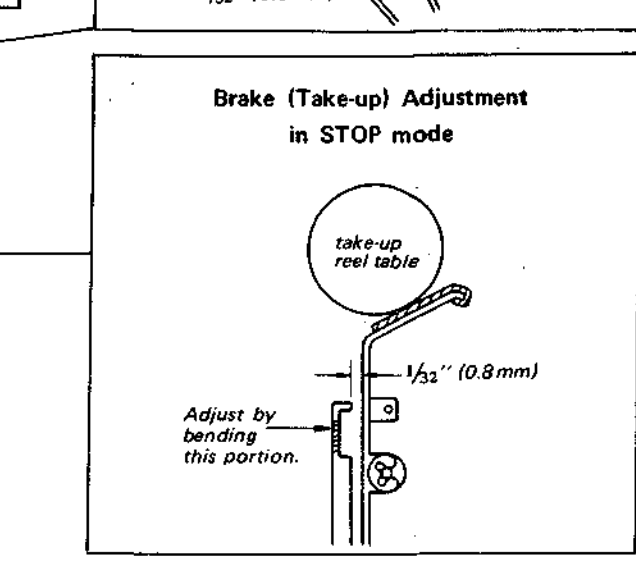
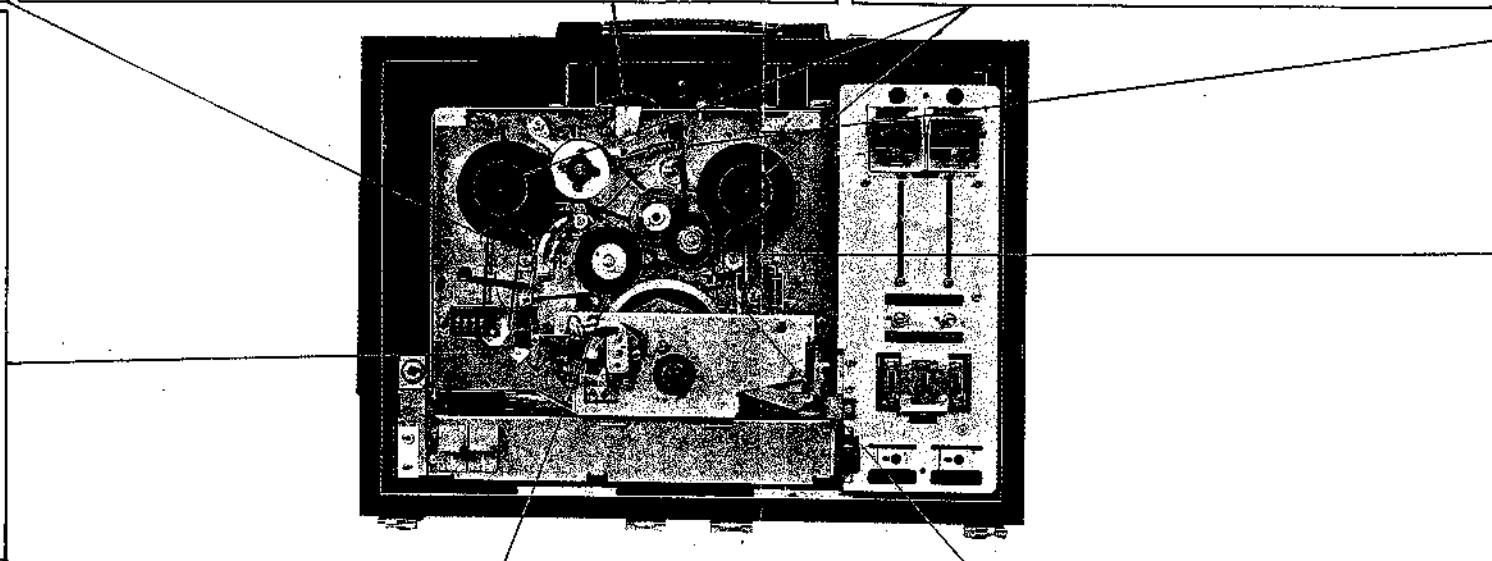
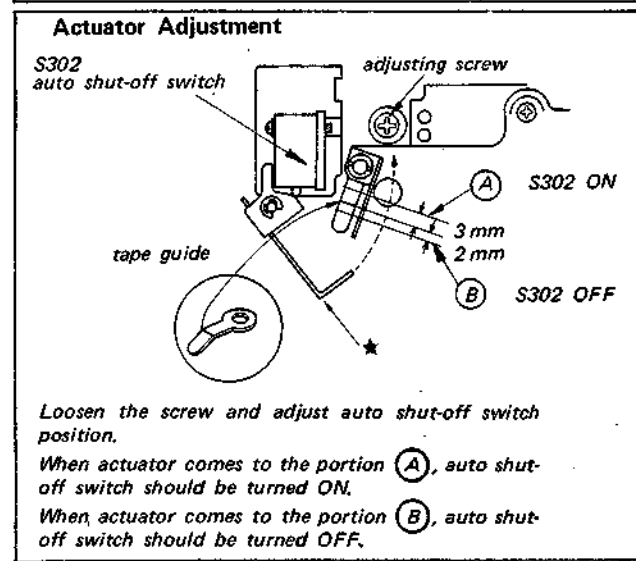
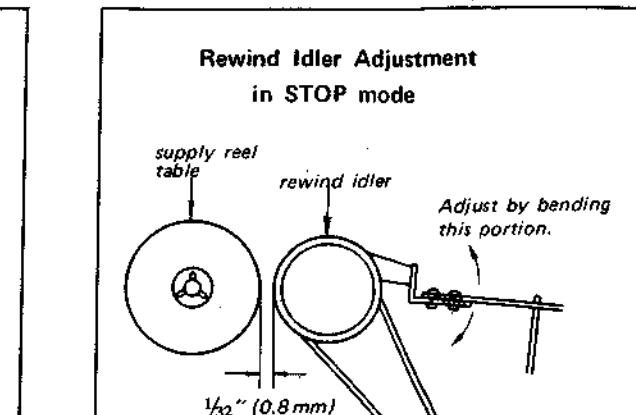
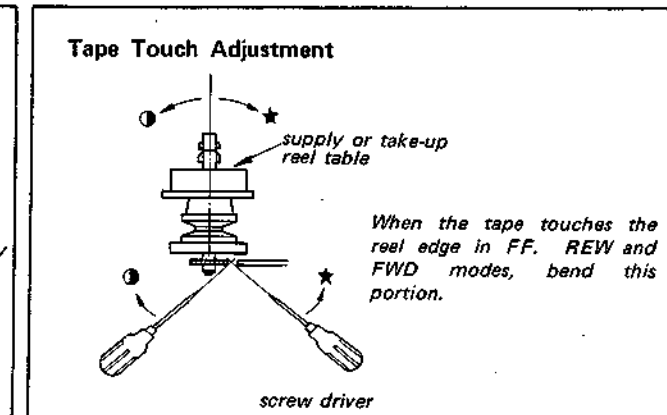
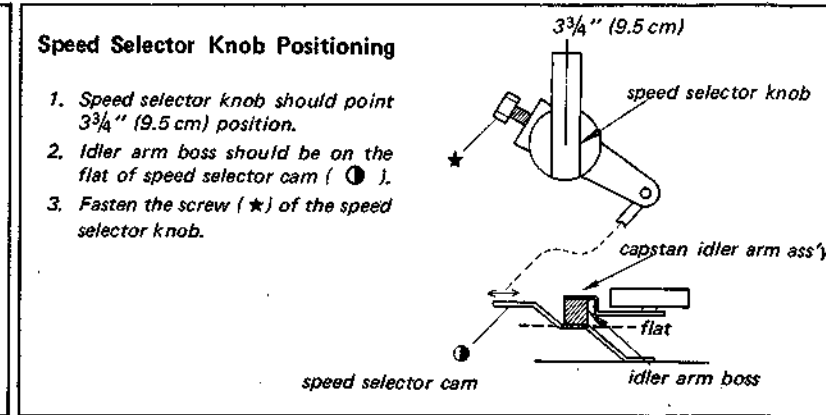
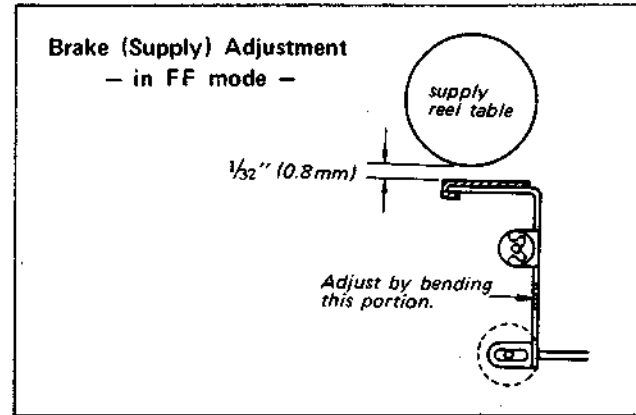

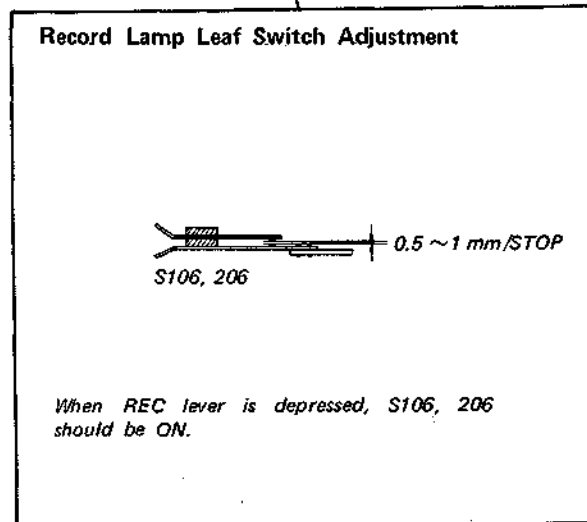
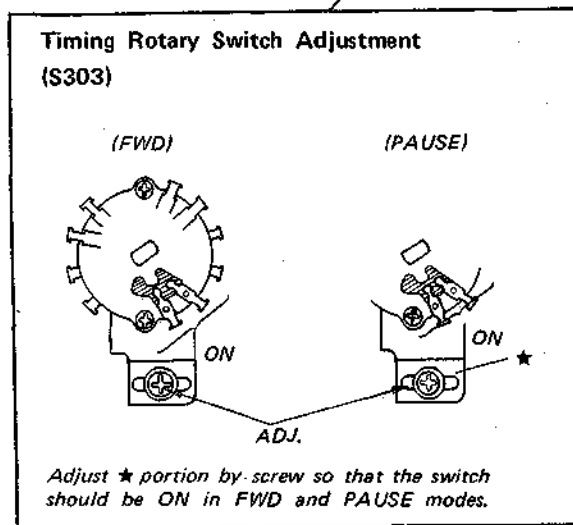
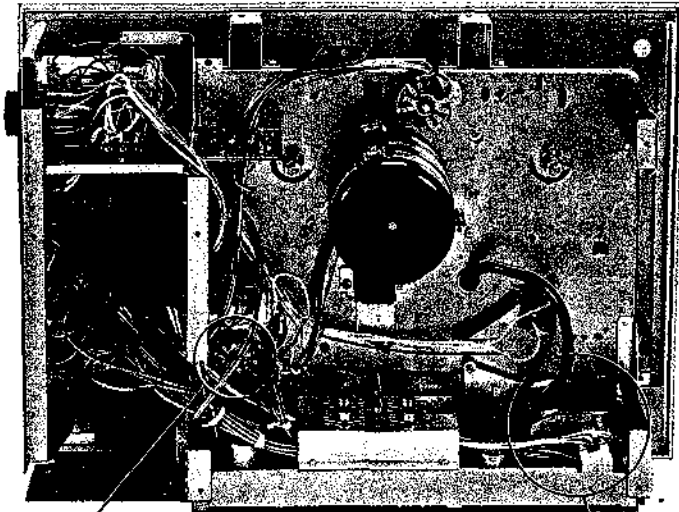

Torque Measurement

- Take-up torque: 300 ± 25 g-cm (4.2 ± 0.3 oz-inch)
- Fast forward torque: 1,200 ± 100 g-cm (16.8 ± 1.4 oz-inch)
- Rewind torque: 1,400 ± 100 g-cm (19.6 ± 1.4 oz-inch)

Back Tension (supply reel table) Measurement

In forward mode: 80~120 g-cm (1.1~1.7 oz-inch)

Pinch Roller Pressure Measurement

1,200 ~ 1,500 g (2.6 ~ 3.3 lb)

3-2. ELECTRICAL ADJUSTMENTS/ MEASUREMENTS

Precautions:

1. Clean the following parts with alcohol moistened swab:
 - record/playback head
 - erase head
 - capstan
 - pinch roller
 - rubber belts
 - idlers
 - tape guides
2. Demagnetize record/playback head with a head demagnetizer.
3. Do not use a magnetized screwdriver for adjustments.
4. Perform the following adjustments in numerical order.
5. Perform the following adjustments for each channel, unless otherwise noted.
6. After adjustment, fix adjusted parts with locking compound.

Test Equipment Required:

- audio oscillator (af osc)
- attenuator 600 Ω (att)
- VTVM
- digital frequency counter

- wow meter
- 1-kHz bandpass filter
- resistors;
 - 10W type 8Ω
 - ¼W type 300Ω, 600Ω
 - 10kΩ, 100kΩ
- blank tape (erased by bulk eraser)
- SONY alignment tapes:

J-19-F1

| | 1 | 2 | 3 | 4 | 5 | 6 | 7 |
|----------------|-----|-----|-----|-----|-----|-----|-----|
| Frequency (Hz) | 10k | 400 | 400 | 10k | 7k | 80 | 40 |
| Level (dB) | -10 | 0 | -10 | -10 | -10 | -10 | -10 |

- SPC-47 (4 kHz, 0 dB)
- WS-19-7 (3 kHz, 0 dB)
- WS-9-7 (3 kHz, 0 dB)

Normal Operating Level

| | Signal Level | Impedance |
|-----------------------|---------------------|----------------|
| MICROPHONE | -60 dB (0.77 mV) | 600 Ω |
| LINE IN | -10 dB (0.25 V) | 10 kΩ |
| LINE OUT | -5 dB (0.44 V) | 100 kΩ load |
| SPEAKER (REC MODE) | +3 dB (1.1 V) | 8 Ω load |
| (playback MODE) | +9 dB (2.2 V) | |

Tape Speed Adjustment

Control/Switch Setting:

SOS switch: OFF
 tape speed selector: 7½ ips 19 cm/s
 SPEAKER switch: OFF
 MODE switch: STEREO
 TONE control: ▼ position
 VOLUME control: mechanical mid.

Procedure:

Mode: playback

SPC-47
 (4 kHz, 0 dB)

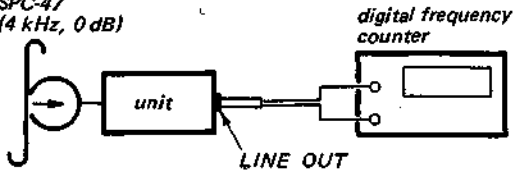

Specification:

counter reading: 3,920 ~ 4,080 Hz

Note: If the counter reading is out of the specified range, replace motor pulley.

| Motor Pulley | | | |
|--------------|----------|----------------|----------------|
| Mark | Diameter | 50 Hz Part No. | 60 Hz Part No. |
| 2 | bigger | 3-486-120-01 | 3-486-121-01 |
| 3 | ↑ ↓ | 3-486-120-11 | 3-486-121-11 |
| 4 | | 3-486-120-21 | 3-486-121-21 |
| 5 | smaller | 3-486-120-31 | 3-486-121-31 |

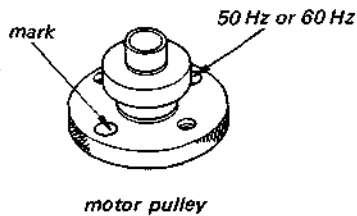

Tape Path Adjustment

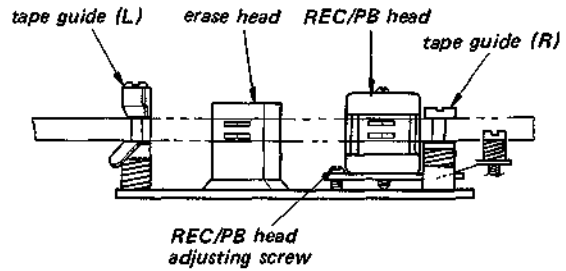

Procedure:

1. Thread a tape and place the unit in playback mode.
2. Align the upper edge of the erase head core and record/playback head core for that of the tape by turning the tape guides (R, L).
3. Turn the tape guides (R, L) clockwise by approximately 35 degrees.

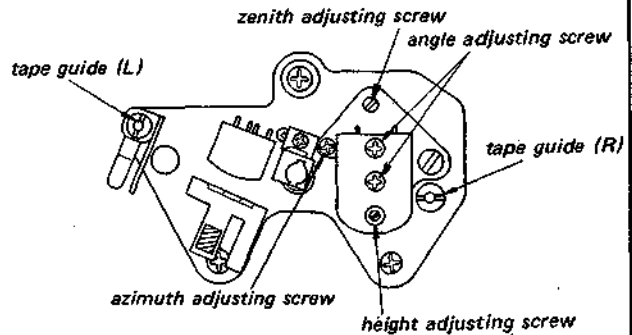

Record/Playback Head Height Adjustment

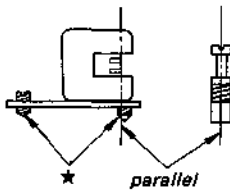

Procedure:

1. Parallel the face of the head and tape guide by adjusting the screws (marked ★).
2. Align the upper edge of the record/playback head core and that of the tape by evenly turning the screws (marked ★).
3. Turn the screws (marked ★) counterclockwise by 20 degrees.

Record/Playback Head Angle Adjustment

Control/Switch Setting:

tape speed selector: 7½ ips 19 cm/s

Procedure:

1. Mode: playback

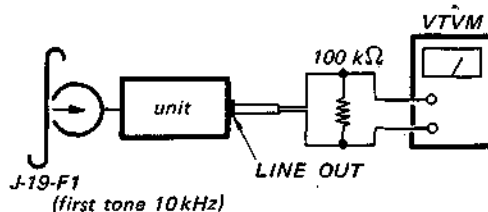

2. Adjust the angle adjusting screws for maximum VTVM reading.

Adjustment Location:

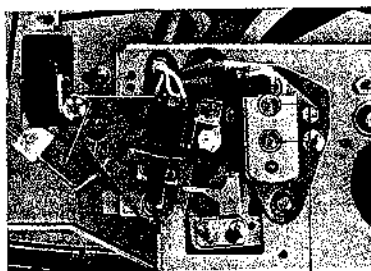

angle adjusting screw

Playback Head Azimuth Adjustment

Control/Switch Setting:

- SOS switch: OFF
- tape speed selector: 7½ ips 19 cm/s
- SPEAKER switch: OFF
- MODE switch: STEREO
- TONE control: ▼ position
- VOLUME control: mechanical mid.

Procedure:

1.

Mode: playback
J-19-F1
first tone 10 kHz

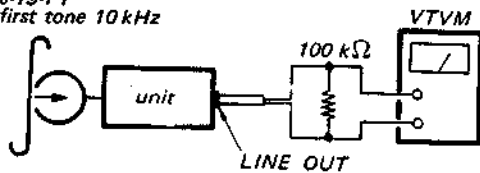

2. Adjust the azimuth adjusting screw for maximum VTVM reading.

Note: If the azimuth angles of L-CH and R-CH are not the same, set the screw midway between two screw positions.

Adjustment Location:

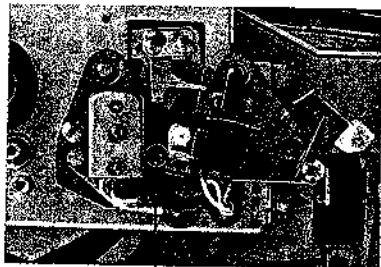

azimuth adjusting screw

Playback Signal-to-Noise Ratio Measurement

Control/Switch Setting:

- SOS switch: OFF
- tape speed selector: 7½ ips 19 cm/s
3¾ ips 9.5 cm/s
- SPEAKER switch: OFF
- MODE switch: STEREO
- TONE control: ▼ position

Procedure:

1.

Mode: playback
J-19-F1
second tone 400 Hz

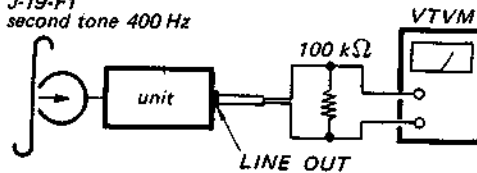

2. Adjust VOLUME control for -5 dB (0.44V) VTVM reading.

3. With no tape threaded

Mode: playback

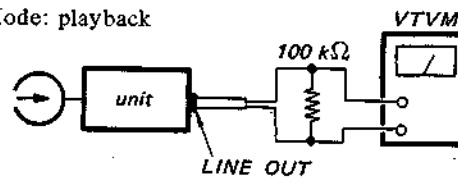

4.
$$-5 \text{ dB} - \frac{\text{VTVM reading (dB) in step 3}}{\text{VTVM reading (dB) in step 2}} = \text{S/N Ratio}$$

5. Specification

| tape speed | S/N ratio |
|------------|------------------|
| 19 cm/s | 46 dB or greater |
| 9.5 cm/s | 44 dB or greater |

Bias Adjustment

Control/Switch Setting:

- tape speed switch: 7½ ips 19 cm/s
- TONE control: ▼ position
- VOLUME control: Position to obtain -5 dB (0.44V) LINE OUTPUT for 1 kHz, -60 dB (0.78 mV) MIC input in record mode.

Procedure:

1. Mode: record

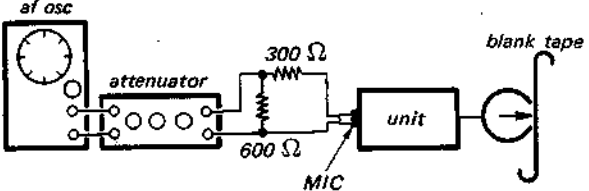

1 kHz, -80 dB (77.5 μV)
10 kHz, -80 dB (77.5 μV)

2. Mode: playback

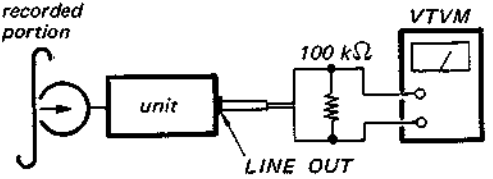

Output level difference should be within 3 dB.

3. If the difference is more than 3 dB, change the tap of T301, (5) ~ (7), (9) ~ (11) as shown in the following figure.

Amp. Circuit Board

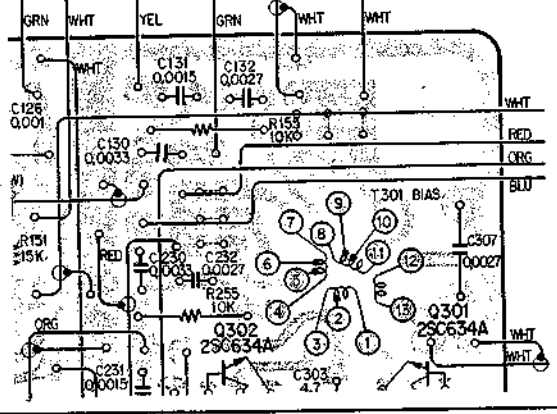

Level Meter Calibration

Control/Switch Setting:

- SOS switch: OFF
- tape speed selector: 7½ ips 19 cm/s
- SPEAKER switch: OFF
- MODE switch: STEREO
- TONE control: ▼ position

Procedure:

- 1.

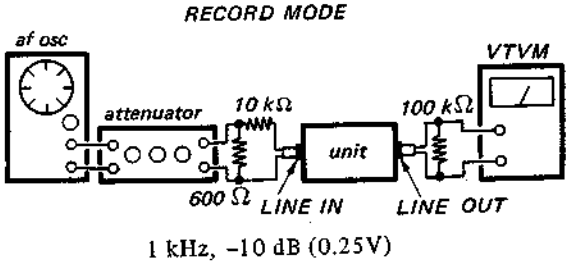

2. Adjust VOLUME control for -5 dB (0.44V) VTVM reading.
3. Adjust R148 (L), R248 (R) for 0 reading on the RECORD LEVEL meter.

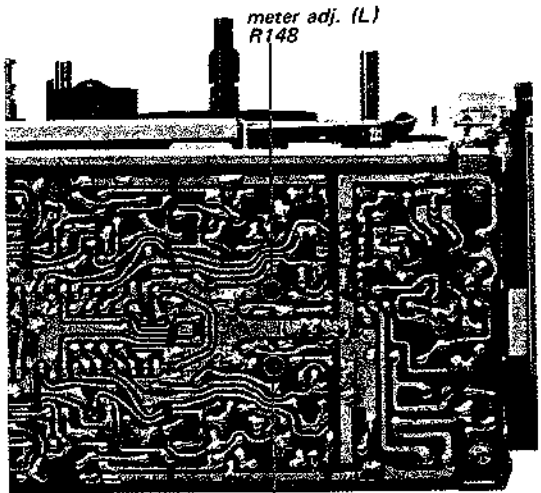

meter adj. (R) R248

Maximum Output Measurement

Control/Switch Setting:

- SOS switch: OFF
- tape speed selector: 7½ ips 19 cm/s
- SPEAKER switch: 2 position
- MODE switch: STEREO
- TONE control: ▼ position
- VOLUME control: 10 max.

Procedure:

1. Mode: playback

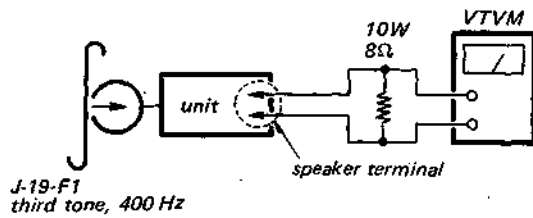

Specification:

more than +18.5 dB (6.25V)

Overall Signal-to-Noise Ratio Measurement

Control/Switch Setting:

- tape speed switch: 7½ ips 19 cm/s
- TONE control: ▼ position
- VOLUME control: Position to obtain -5 dB (0.44V) LINE OUTPUT for 1 kHz, -60 dB (0.78 mV) MIC input in record mode.

Procedure:

1. Mode: record

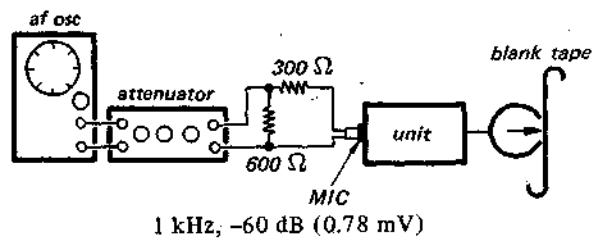

2. Mode: record

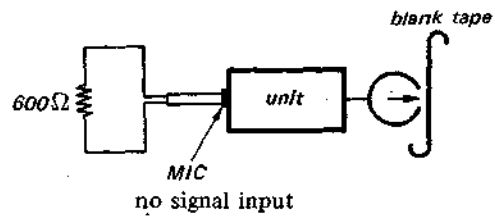

3. Mode: playback

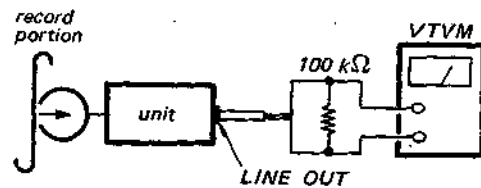

| Recorded Signal | VTVM Reading |
|-----------------|---|
| 1 kHz | Adjust VOLUME control for -5 dB (0.44V) |
| no signal | -48 dB (3.08 mV) or less |

Erase Ratio Measurement

Control/Switch Setting:

- tape speed switch: 7½ ips 19 cm/s
- TONE control: ▼ position
- VOLUME control: Position to obtain -5 dB (0.44V) LINE OUTput for 1 kHz, -60 dB (0.78 mV) MIC input in record mode.

Procedure:

1. Mode: record

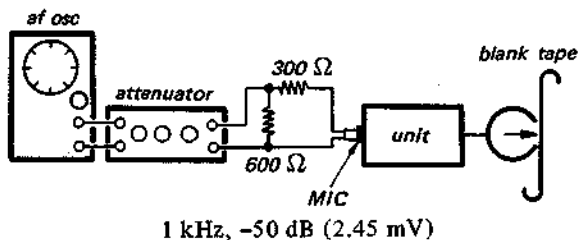

2. Rewind half of the recorded part.

3. Mode: record

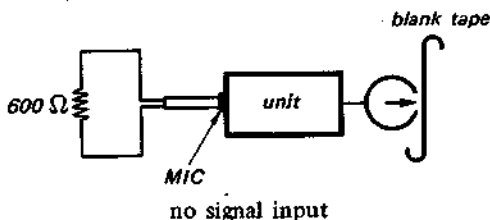

4. Mode: playback

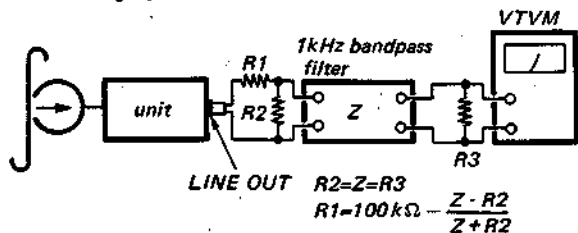

| Recorded Signal | VTVM Reading |
|-----------------|---|
| 1 kHz | Adjust VOLUME control for -5 dB (0.44V) |
| no signal | -70 dB (0.25 mV) or less |

TONE Control Range Check

Control/Switch Setting:

- SOS switch: OFF
- tape speed selector: 7½ ips 19 cm/s
- SPEAKER switch: OFF
- MODE switch: STEREO
- TONE control: ▼ position
- VOLUME control: mechanical mid.

Procedure:

1. Mode: playback

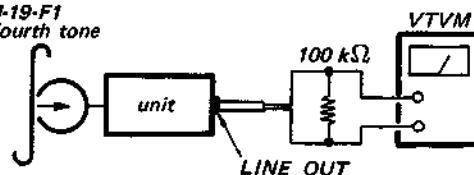

- 2.

| TONE Control Setting | Output Level Difference |
|----------------------|-------------------------|
| ▼ position | 0 dB |
| HIGH max. | approx. +10 dB |
| LOW max. | approx. -10 dB |

Wow and Flutter Measurement

Control/Switch Setting:

VOLUME control: 5 position

TONE control: mechanical mid position

Procedure:

Note: Measure wow and flutter for beginning, midway and end portion of tapes in both vertical and horizontal set positions.

1. at $7\frac{1}{2}$ ips (19 cm/s)

Mode: playback

WS-19-7
3 kHz, 0 dB

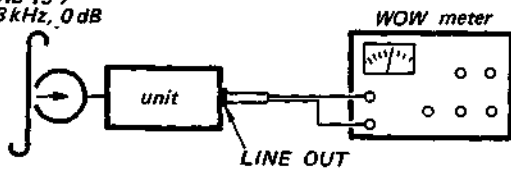

Specification: 0.19% RMS or less

2. at $3\frac{3}{4}$ ips (9.5 cm/s)

Mode: playback

WS-9-7
(3 kHz, 0 dB)

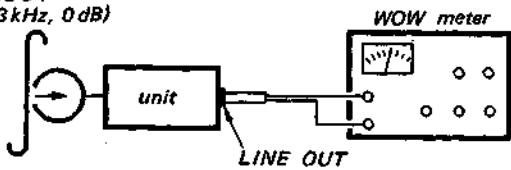

Specification: 0.24% RMS or less

3. at $1\frac{7}{8}$ ips (4.8 cm/s)

Mode: record

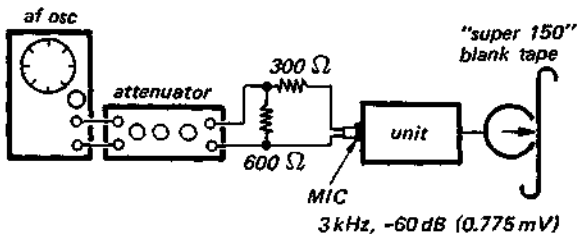

Mode: playback

recorded portion

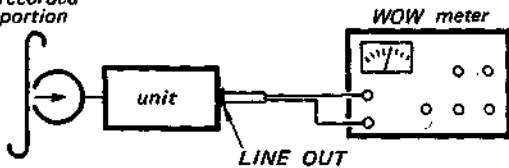

Specification: 0.4% RMS or less

POWER FREQUENCY ADAPTATION

The **MOTOR PULLEY** and tapping of the **MOTOR STARTING CAPACITOR TERMINALS** must be altered if the line frequency differs from what the recorder is set for.

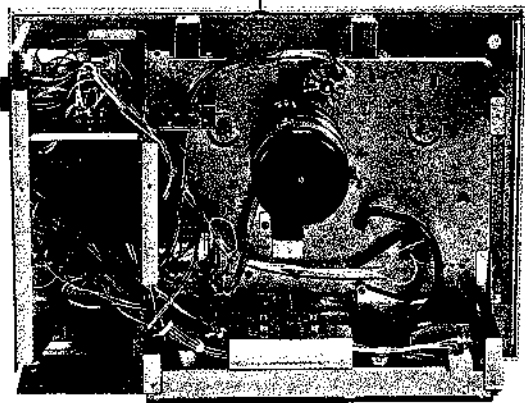
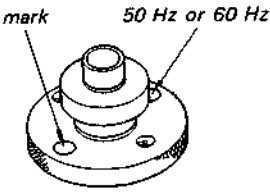
| Connection of Motor Starting Capacitor | Motor Pulley |
|--|--|
| <p>green jumper wire is connected 50 Hz green jumper wire is removed 60 Hz</p> <p style="text-align: center;"><i>green jumper wire</i></p>  | <p>Change motor pulley. Use motor pulley with same mark of 2~6.</p> <p>50 Hz (mark) (Part No.) 2 3-486-120-01 3 3-486-120-11 4 3-486-120-21 5 3-486-120-31</p> <p>60 Hz (mark) (Part No.) 2 3-486-121-01 3 3-486-121-11 4 3-486-121-21 5 3-486-121-31</p>  <p style="text-align: center;"><i>motor pulley</i></p> |

TC-270 TC-270

4.2. SCHEMATIC DIAGRAM

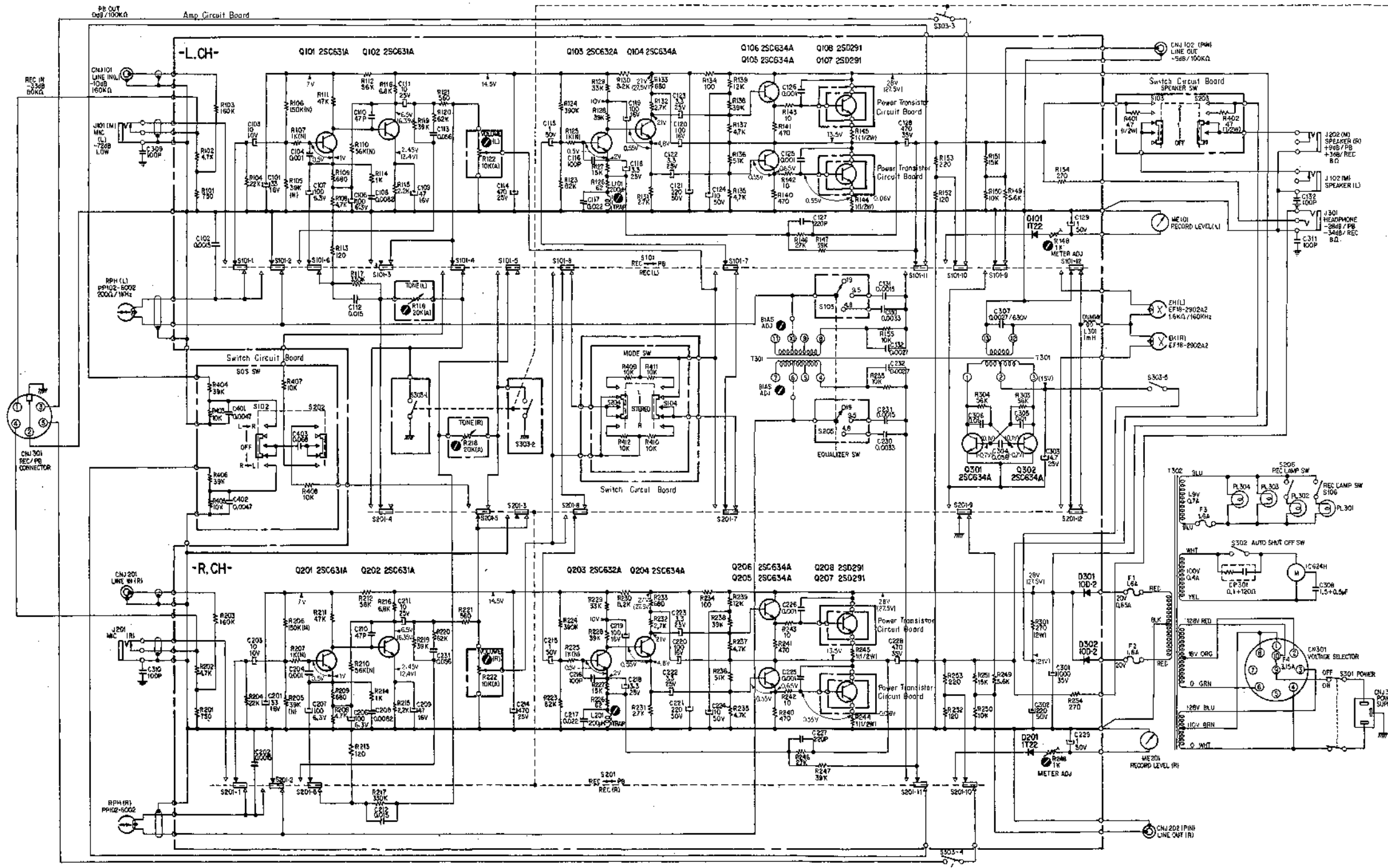

Note: 1. All resistors and capacitors are rated in Ω and μF , unless otherwise specified.
 2. Voltage values shown are measured with a voltmeter (20 k Ω /V) in playback mode. Voltage values in () are measured in record mode. Variations may be noted because of normal production tolerances.
 3. Symbols
 \triangle Chassis ground
 \bigcirc Common ground on circuit board
 N Low noise resistor

| 4. Switch position (Ref. No.) | (Description) | (Position) |
|-------------------------------|------------------------|------------|
| S101, 201 | record/playback switch | PB |
| S102, 202 | SOS switch | OFF |
| S103, 203 | SPEAKER switch | OFF |
| S104, 204 | MODE switch | STEREO |
| S105, 205 | equalizer | 19 cm/sec |
| S106, 206 | record lamp switch | OFF |
| S301 | POWER switch | ON |
| S302 | auto shut-off switch | OFF |
| S303 | timing switch | forward |

4.3. MOUNTING DIAGRAM - Conductor Side -

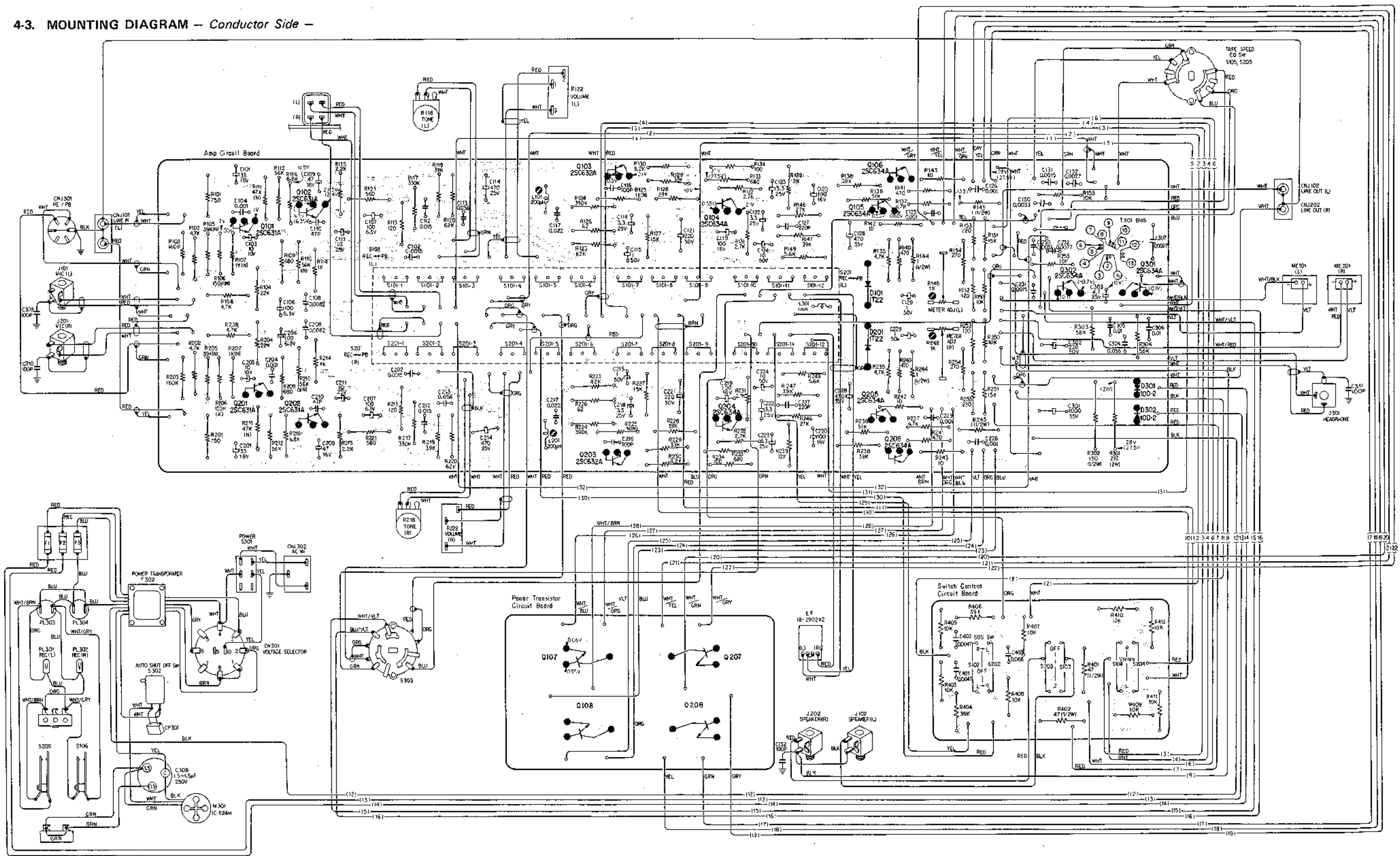

- | | | | | | | | |
|---------|-------------------------------|--------|---------------------|-------|-----------|-------|-----------|
| 2SC631A | Q101, 102, 103, 104, 105, 106 | 2SD291 | Q107, 108, 207, 208 | 1T-22 | D101, 201 | 10D-2 | D301, 302 |
| 2SC632A | Q201, 202, 203, 204, 205, 206 | | | | | | |
| 2SC634A | Q301, 302 | | | | | | |

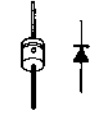
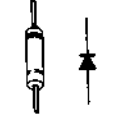
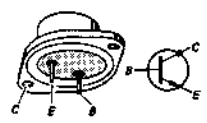
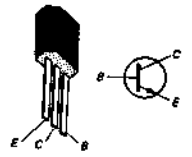

SECTION 5
EXPLODED VIEWS

5-1. CABINET — Top View —

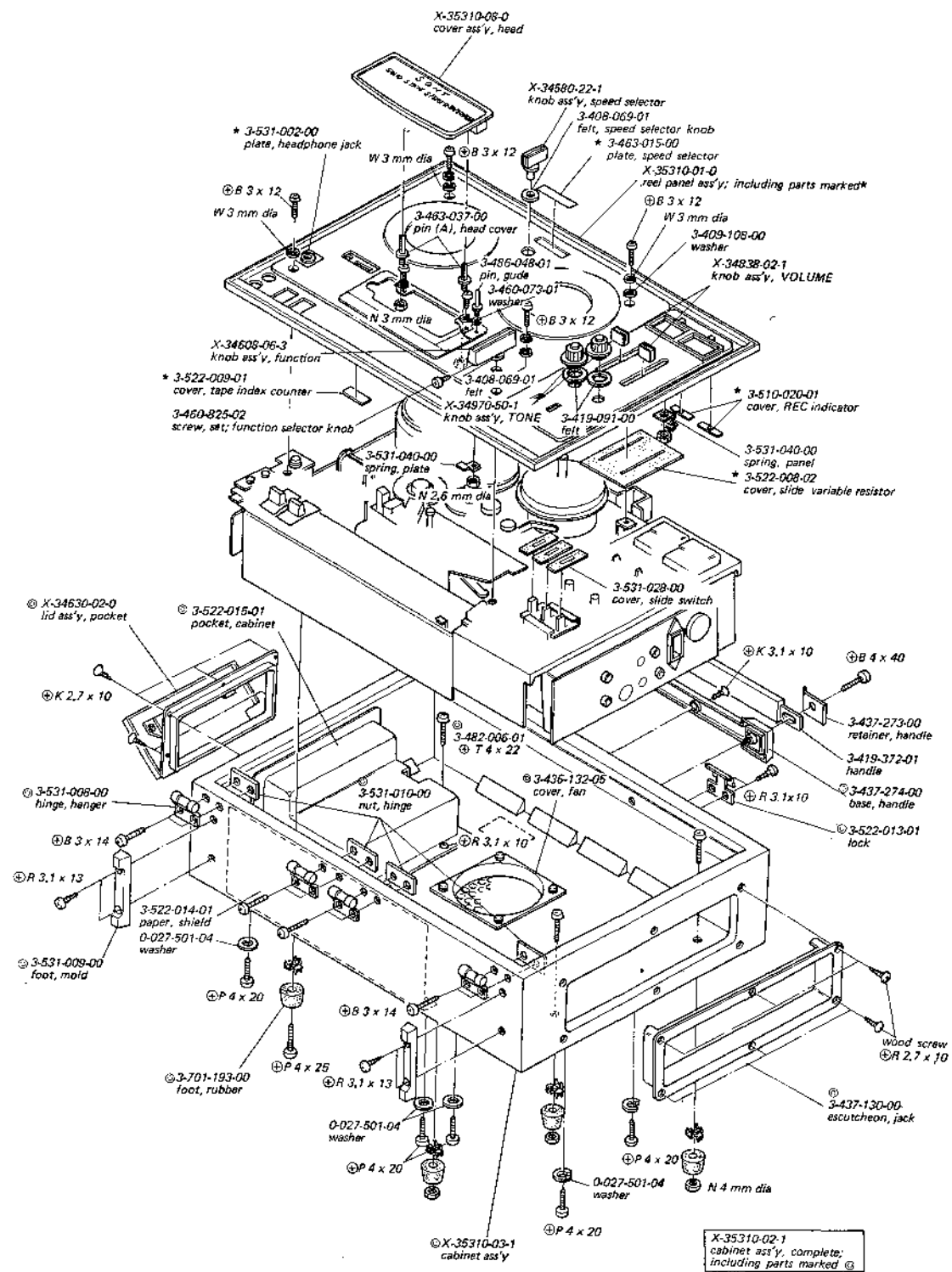

5-2. SPEAKER

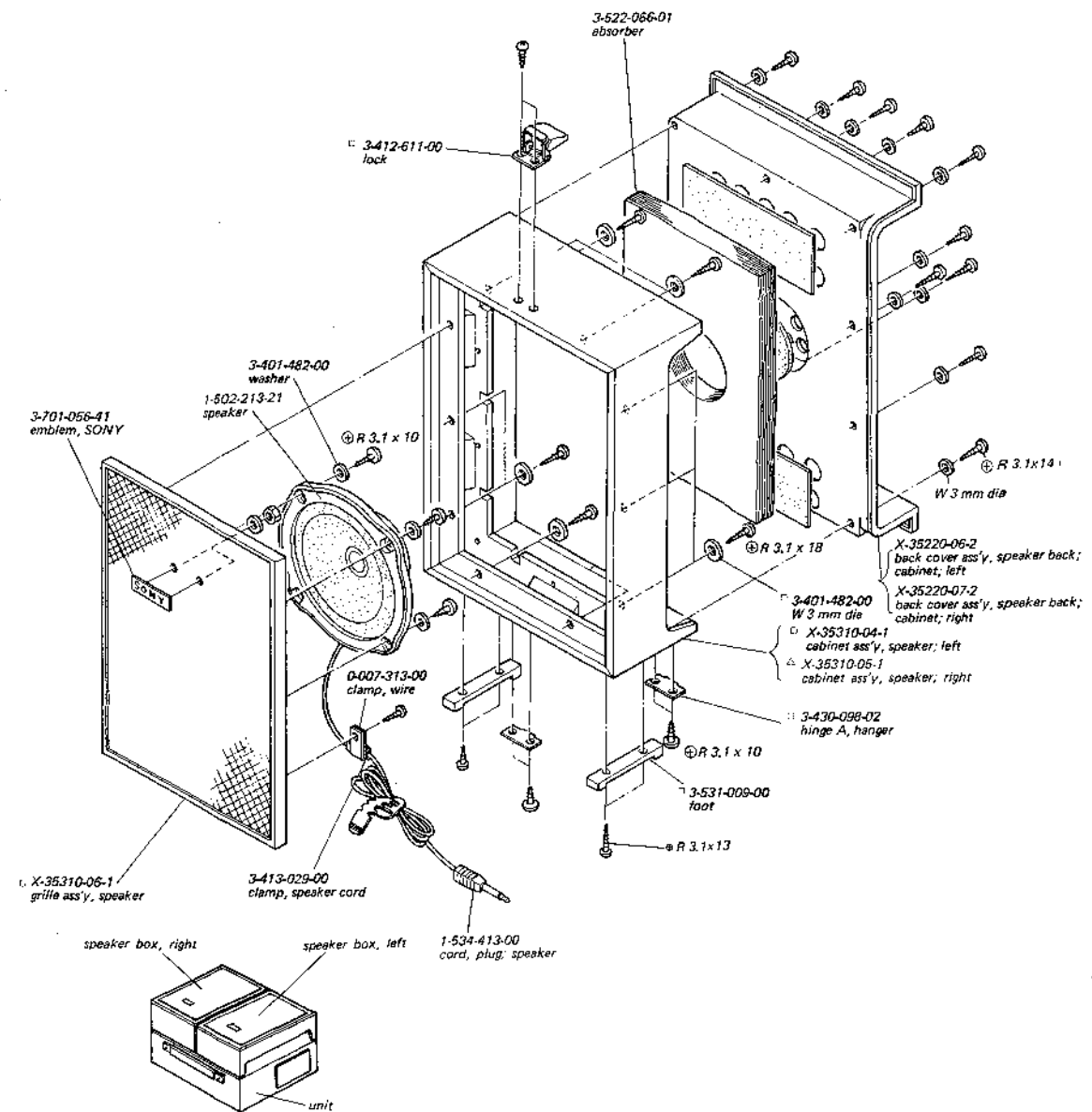

5-4. HEAD DECK - Upper -

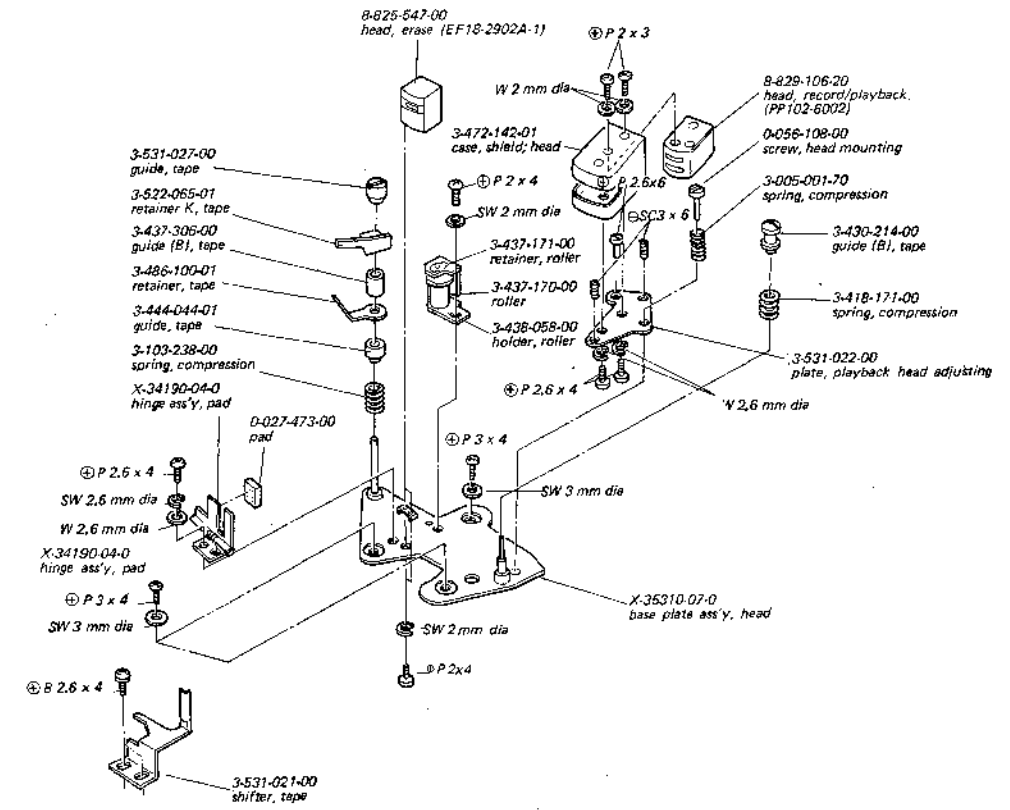

5-5. CONTROL CHASSIS

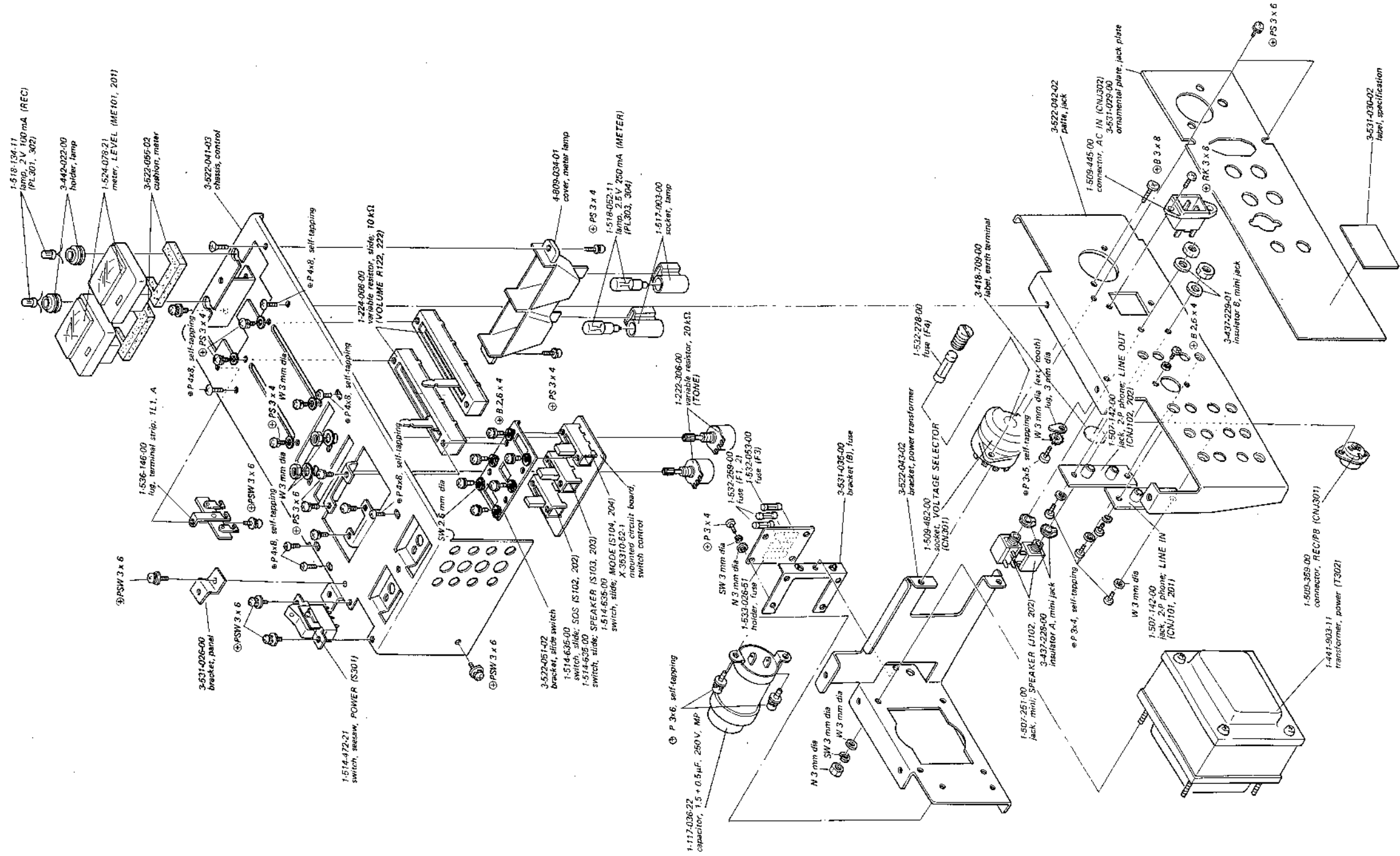

5-7. HEAD DECK - Lower -

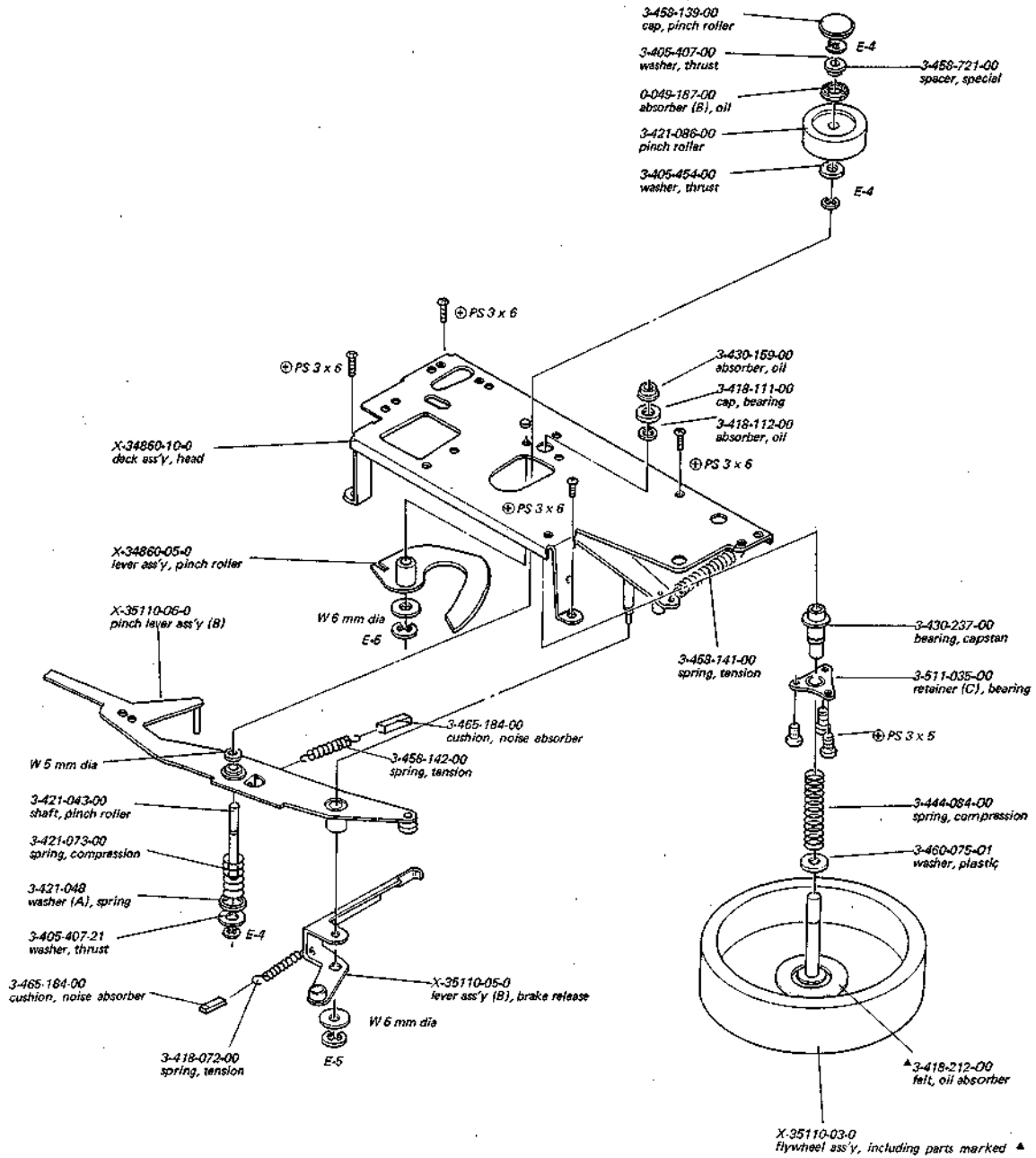

5-8. CHASSIS — Lower —

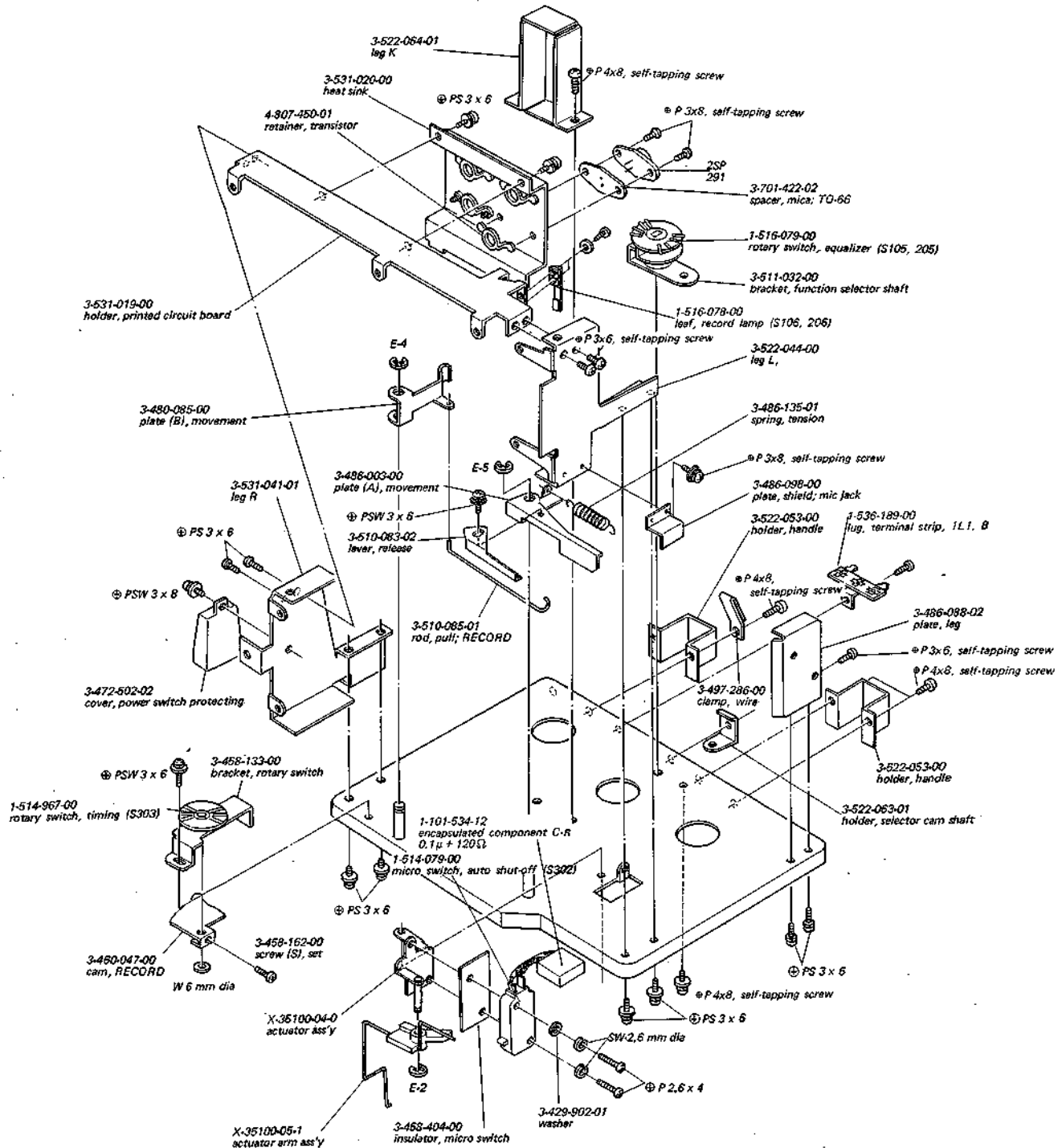

5.9. PACKING

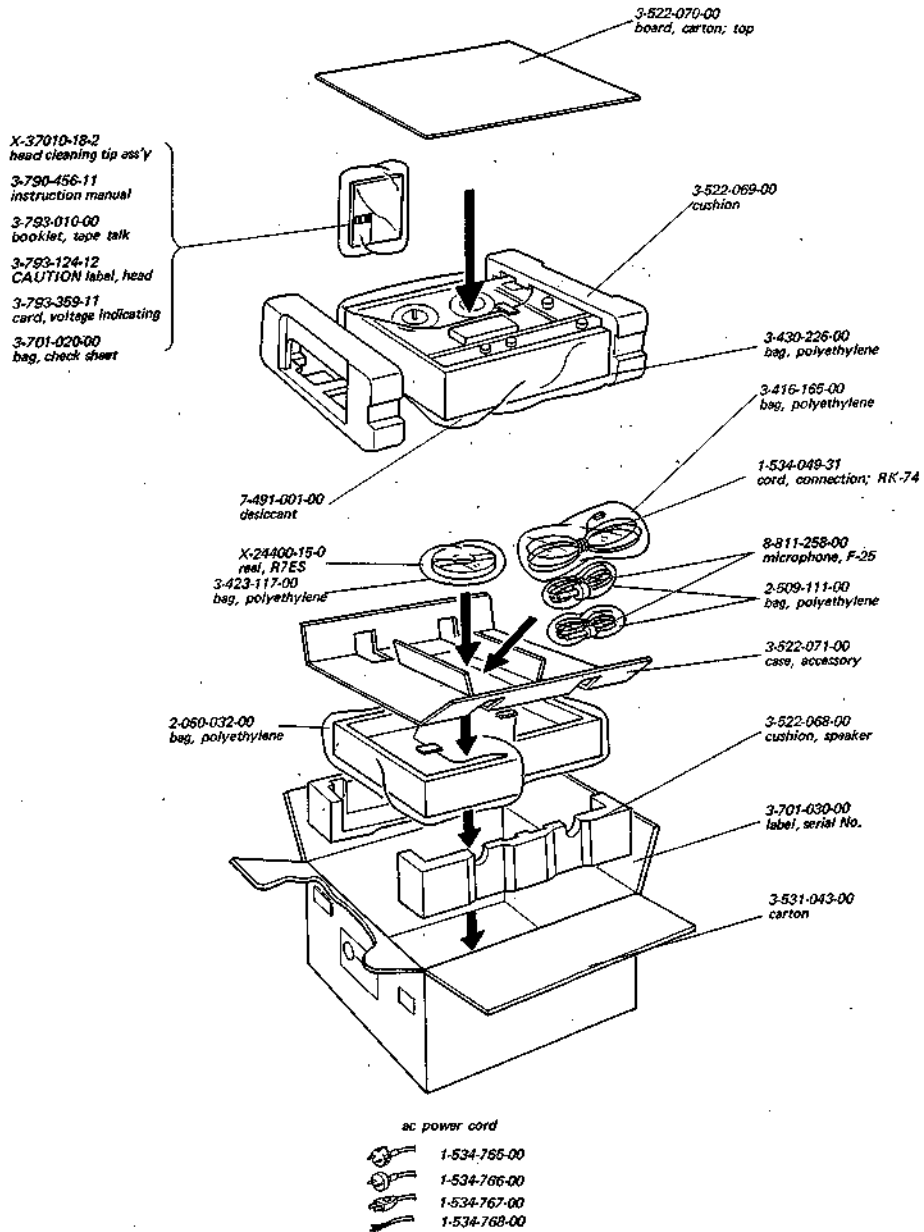

**SECTION 6
ELECTRICAL PARTS LIST**

Ref. No. Part No. Description

MOUNTED CIRCUIT BOARDS

X-35310-51-1 power transistor
X-35310-52-1 switch control
X-35310-53-1 amp

SEMICONDUCTORS

| | | | |
|-----------|--|------------|---------|
| Q101, 201 | | transistor | 2SC631A |
| Q102, 202 | | transistor | 2SC631A |
| Q103, 203 | | transistor | 2SC632A |
| Q104, 204 | | transistor | 2SC634A |
| Q105, 205 | | transistor | 2SC634A |
| Q106, 206 | | transistor | 2SC634A |
| Q107, 207 | | transistor | 2SD291 |
| Q108, 208 | | transistor | 2SD291 |
| Q301, 302 | | transistor | 2SC634A |
| D101, 201 | | diode | 1T-22 |
| D301, 302 | | diode | 10D-2 |

COILS

| | | | |
|-----------|--------------|-------|-------------|
| L101, 201 | 1-409-132-00 | trap | 200 μ H |
| L301 | 1-431-038-00 | dummy | 1 mH |

TRANSFORMERS

| | | |
|------|--------------|----------|
| T301 | 1-433-136-00 | bias osc |
| T302 | 1-441-903-11 | power |

CAPACITORS

All capacitors are in μ F unless otherwise indicated.
(p = μ , elect = electrolytic)

| | | | | |
|-----------|--------------|--------|-------|---------------|
| C101, 201 | 1-121-403-11 | 33 | 16 V | elect |
| C102, 202 | 1-105-663-12 | 0.0015 | 50 V | mylar |
| C103, 203 | 1-121-469-11 | 10 | 10 V | elect |
| C104, 204 | 1-105-661-12 | 0.001 | 50 V | mylar |
| C105, 205 | | ----- | | |
| C106, 206 | 1-121-413-11 | 100 | 6.3 V | elect |
| C107, 207 | 1-121-413-11 | 100 | 6.3 V | elect |
| C108, 208 | 1-105-672-12 | 0.0082 | 50V | mylar |
| C109, 209 | 1-121-409-11 | 47 | 16V | elect |
| C110, 210 | 1-107-123-11 | 47 p | 50V | silvered mica |
| C111, 211 | 1-121-398-11 | 10 | 25V | elect |
| C112, 212 | 1-105-675-12 | 0.015 | 50V | mylar |
| C113, 213 | 1-105-682-12 | 0.056 | 50V | mylar |
| C114, 214 | 1-121-733-11 | 470 | 25V | elect |
| C115, 215 | 1-121-391-11 | 1 | 50V | elect |
| C116, 216 | 1-107-131-11 | 100 p | 50V | silvered mica |
| C117, 217 | 1-105-677-12 | 0.022 | 50V | mylar |
| C118, 218 | 1-121-392-11 | 3.3 | 25V | elect |

Ref. No. Part No. Description

| | | | | |
|-----------|--------------|-----------|------|--------------------|
| C119, 219 | 1-121-415-11 | 100 | 16V | elect |
| C120, 220 | 1-121-415-11 | 100 | 16V | elect |
| C121, 221 | 1-121-423-11 | 220 | 50V | elect |
| C122, 222 | 1-121-392-11 | 3.3 | 25V | elect |
| C123, 223 | 1-121-392-11 | 3.3 | 25V | elect |
| C124, 224 | 1-121-738-11 | 10 | 50V | elect |
| C125, 225 | 1-105-661-12 | 0.001 | 50V | mylar |
| C126, 226 | 1-105-661-12 | 0.001 | 50V | mylar |
| C127, 227 | 1-107-139-11 | 220 p | 50V | silvered mica |
| C128, 228 | 1-121-361-11 | 470 | 35V | elect |
| C129, 229 | | ----- | | |
| C130, 230 | 1-105-667-12 | 0.0033 | 50V | mylar |
| C131, 231 | 1-105-663-12 | 0.0015 | 50V | mylar |
| C132, 232 | 1-105-666-12 | 0.0027 | 50V | mylar |
| C301 | 1-121-388-11 | 1000 | 35V | elect |
| C302 | 1-121-423-11 | 220 | 50V | elect |
| C303 | 1-121-395-11 | 4.7 | 10V | elect |
| C304 | 1-105-682-12 | 0.056 | 50V | mylar |
| C305 | 1-105-673-12 | 0.01 | 50V | mylar |
| C306 | 1-105-673-12 | 0.01 | 50V | mylar |
| C307 | 1-129-707-11 | 0.0027 | 630V | polypropylene film |
| C308 | 1-117-036-22 | 1.5 + 0.5 | 250V | MP |
| C309 | 1-107-004-11 | 100 p | 50V | silvered mica |
| C310 | 1-107-004-11 | 100 p | 50V | silvered mica |
| C311 | 1-107-004-11 | 100 p | 50V | silvered mica |
| C312 | 1-107-004-11 | 100 p | 50V | silvered mica |
| C401 | 1-105-669-12 | 0.0047 | 50V | mylar |
| C402 | 1-105-669-12 | 0.0047 | 50V | mylar |
| C403 | 1-105-683-12 | 0.0047 | 50V | mylar |

RESISTORS

All resistors are $\frac{1}{4}$ W, carbon type and in Ω unless otherwise indicated. (k = 1000)

| | | |
|-----------|--------------|-------|
| R101, 201 | 1-244-705-11 | 750 |
| R102, 202 | 1-244-689-11 | 4.7 k |
| R103, 203 | 1-244-726-11 | 160 k |
| R104, 204 | 1-244-705-11 | 22 k |
| R105, 205 | 1-244-711-11 | 39 k |
| R106, 206 | 1-244-725-11 | 150 k |
| R107, 207 | 1-244-673-11 | 1 k |
| R108, 208 | 1-244-689-11 | 4.7 k |
| R109, 209 | 1-244-669-11 | 680 |
| R110, 210 | 1-244-715-11 | 56 k |
| R111, 211 | 1-244-713-11 | 47 k |
| R112, 212 | 1-244-715-11 | 56 k |
| R113, 213 | 1-244-651-11 | 120 |
| R114, 214 | 1-244-673-11 | 1 k |
| R115, 215 | 1-244-681-11 | 2.2 k |
| R116, 216 | 1-244-693-11 | 6.8 k |

| <u>Ref. No.</u> | <u>Part No.</u> | <u>Description</u> |
|-----------------|-----------------|------------------------|
| R117, 217 | 1-244-733-11 | 330 k |
| R118, 218 | 1-222-306-11 | 20 k variable (TONE) |
| R119, 219 | 1-244-711-11 | 39 k |
| R120, 220 | 1-244-716-11 | 62 k |
| R121, 221 | 1-244-667-11 | 560 |
| R122, 222 | 1-224-008-00 | 10 k variable (VOUUME) |
| R123, 223 | 1-244-719-11 | 82 k |
| R124, 224 | 1-244-735-11 | 390 k |
| R125, 225 | 1-244-673-11 | 1 k |
| R126, 226 | 1-244-644-11 | 62 |
| R127, 227 | 1-244-701-11 | 15 k |
| R128, 228 | 1-244-711-11 | 39 k |
| R129, 229 | 1-244-709-11 | 33 k |
| R130, 230 | 1-244-695-11 | 8.2 k |
| R131, 231 | 1-244-683-11 | 2.7 k |
| R132, 232 | 1-244-683-11 | 2.7 k |
| R133, 233 | 1-244-669-11 | 680 |
| R134, 234 | 1-244-649-11 | 100 |
| R135, 235 | 1-244-689-11 | 4.7 k |
| R136, 236 | 1-244-714-11 | 51 k |
| R137, 237 | 1-244-689-11 | 4.7 k |
| R138, 238 | 1-244-711-11 | 39 k |
| R139, 239 | 1-244-699-11 | 12 k |
| R140, 240 | 1-244-665-11 | 470 |
| R141, 241 | 1-244-665-11 | 470 |
| R142, 242 | 1-244-625-11 | 10 |
| R143, 243 | 1-244-625-11 | 10 |
| R144, 244 | 1-244-801-11 | 1 ½W |
| R145, 245 | 1-244-801-11 | 1 ½W |
| R146, 246 | 1-244-707-11 | 27 k |
| R147, 247 | 1-244-711-11 | 39 k |
| R148, 248 | 1-222-771-00 | 1 k (B), semi-fixed |
| R149, 249 | 1-244-691-11 | 5.6 k |
| R150, 250 | 1-244-697-11 | 10 k |
| R151, 251 | 1-244-701-11 | 15 k |
| R152, 252 | 1-244-651-11 | 120 |
| R153, 253 | 1-244-657-11 | 220 |
| R154, 254 | 1-244-659-11 | 270 |
| R155, 255 | 1-244-697-11 | 10 k |
| R301 | 1-244-859-11 | 270 |
| R302 | 1-244-853-11 | 150 |
| R303 | | ----- |
| R304 | 1-244-715-11 | 56 k |
| R305 | 1-244-715-11 | 56 k |
| R401 | 1-244-841-11 | 47 |
| R402 | 1-244-841-11 | 47 |
| R403 | 1-244-697-11 | 10 k |
| R404 | 1-244-711-11 | 39 k |
| R405 | 1-244-697-11 | 10 k |

| <u>Ref. No.</u> | <u>Part No.</u> | <u>Description</u> |
|-----------------|-----------------|--------------------|
| R406 | 1-244-711-11 | 39 k |
| R407 | 1-244-697-11 | 10 k |
| R408 | 1-244-697-11 | 10 k |
| R409 | 1-244-697-11 | 10 k |
| R410 | 1-244-697-11 | 10 k |

SWITCHES

| | | |
|-----------|--------------|------------------------|
| S101, 201 | 1-516-077-00 | slide, record/playback |
| S102, 202 | 1-514-635-00 | slide, SOS |
| S103, 203 | 1-514-635-00 | slide SPEAKER |
| S104, 204 | 1-514-635-00 | slide, MODE |
| S105, 205 | 1-516-079-00 | rotary, equalizer |
| S106, 206 | 1-516-078-00 | leaf, record lamp |
| S301 | 1-514-472-21 | seesaw, POWER |
| S302 | 1-514-079-00 | micro, auto shut-off |
| S303 | 1-514-967-00 | rotary, timing |

JACKS

| | | |
|--------------------|--------------|---------------------|
| J101, 201 | 1-507-251-00 | mini, MICROPHONE |
| J102, 202 | 1-507-251-00 | mini, SPEAKER |
| J301 | 1-507-282-00 | binaural, HEADPHONE |
| CNJ 101 } 201 } | 1-507-142-00 | 2 p phono, LINE IN |
| CNJ 102 } 202 } | | |
| CNJ 301 | 1-509-359-00 | connector, REC/PB |
| CNJ 302 | 1-509-445-00 | connector, AC IN |

MISCELLANEOUS

| | | |
|------------|--------------|--|
| CN301 | 1-509-482-00 | socket, VOLTAGE SELECTOR |
| PL303, 304 | 1-518-052-11 | lamp, 2.5 V 250 mA (METER) |
| PL301, 302 | 1-518-134-11 | lamp, 2 V 100 mA (REC) |
| ME101, 201 | 1-524-078-21 | meter, RECORD LEVEL |
| F1, 2 | 1-532-259-00 | fuse, 1.6 AT |
| F3 | 1-532-053-00 | fuse, 1.6 A |
| F4 | 1-532-278-00 | fuse, 3.15A |
| | 1-533-026-51 | holder, fuse |
| | 1-534-413-00 | cord, plug; speaker |
| CP301 | 1-101-534-12 | encapsulated component C-R 0.1 μ + 120Ω |
| EH | 8-825-547-00 | head, erase (EF18-2902A-1) |
| R PH | 8-829-106-20 | head, record/playback (PP102-6002) |
| | 1-536-146-00 | lug, terminal strip; 1-L-1. A |
| | 1-536-189-00 | lug, terminal strip; 1-L-1. B |
| M | 8-832-624-25 | motor, IC624H |
| SP | 1-502-213-21 | speaker |
| | 1-517-003-00 | socket, lamp |

**SECTION 7
HARDWARE**

| <u>Part No.</u> | <u>Description</u> | <u>Part No.</u> | <u>Description</u> |
|-----------------|-------------------------|------------------------|----------------------|
| SCREWS | | | |
| 7-621-255-15 | ⊕ P 2 x 3 | 7-685-145-51 | ⊕ P 3 x 6 |
| 7-621-255-25 | ⊕ P 2 x 4 | 7-685-159-51 | ⊕ P 4 x 8 |
| 7-621-255-35 | ⊕ P 2 x 5 | 7-685-547-21 | ⊕ B 3 x 10 |
| 7-621-259-25 | ⊕ P 2.6 x 4 | NUTS | |
| 7-621-259-35 | ⊕ P 2.6 x 5 | 7-622-307-02 | 2.6 mm dia |
| 7-621-259-37 | ⊕ P 2.6 x 5 | 7-684-013-01 | 3 mm dia |
| 7-621-259-45 | ⊕ P 2.6 x 6 | 7-684-014-01 | 4 mm dia |
| 7-621-259-85 | ⊕ P 2.6 x 14 | 7-684-033-01 | 3 mm dia |
| 7-621-773-86 | ⊕ B 2.6 x 4 | WASHERS | |
| 7-621-843-25 | ⊕ R 3.1 x 10 | 7-623-105-12 | 2 mm dia |
| 7-621-843-35 | ⊕ R 3.1 x 13 | 7-623-107-12 | 2.6 mm dia |
| 7-621-843-45 | ⊕ R 3.1 x 16 | 7-623-108-02 | 3 mm dia |
| 7-628-254-05 | ⊕ P 2.6 x 5 | 7-623-108-12 | 3 mm dia |
| 7-682-145-01 | ⊕ P 3 x 4 | 7-623-108-20 | 3 mm dia |
| 7-682-146-01 | ⊕ P 3 x 5 | 7-623-110-09 | 4 mm dia |
| 7-682-147-01 | ⊕ P 3 x 6 | 7-623-110-12 | 4 mm dia |
| 7-682-149-01 | ⊕ P 3 x 10 | | 5 mm dia |
| 7-682-165-05 | ⊕ P 4 x 16 | 7-623-113-18 | 6 mm dia |
| 7-682-347-04 | ⊕ RK 3 x 6 | 7-623-113-27 | 6 mm dia |
| 7-682-351-04 | ⊕ RK 3 x 14 | 7-623-205-22 | 2 mm dia (small) |
| 7-682-547-01 | ⊕ B 3 x 6 | 7-623-207-22 | 2.6 mm dia (small) |
| 7-682-548-05 | ⊕ B 3 x 8 | 7-623-208-22 | 3 mm dia (small) |
| 7-682-549-04 | ⊕ B 3 x 10 | 7-623-208-27 | 3 mm dia (small) |
| 7-682-569-05 | ⊕ B 4 x 35 | 7-623-210-28 | 4 mm dia (small) |
| 7-682-547-14 | ⊕ B 3 x 6 | 7-623-308-05 | 3 mm dia, int. tooth |
| 7-682-562-01 | ⊕ B 4 x 10 | 7-623-408-05 | 3 mm dia, ext. tooth |
| 7-682-647-01 | ⊕ PS 3 x 6 | RETAINING RINGS | |
| 7-682-661-01 | ⊕ PS 4 x 8 | 7-624-104-01 | E-2 |
| 7-682-662-01 | ⊕ PS 4 x 10 | 7-624-106-05 | E-3 |
| 7-682-947-01 | ⊕ PSW 3 x 6 | 7-624-108-05 | E-4 |
| 7-682-948-01 | ⊕ PSW 3 x 8 | 7-624-109-05 | E-5 |
| 7-682-949-01 | ⊕ PSW 3 x 10 | LUG | |
| 7-683-137-00 | ⊖ SC 3 x 3 | 7-623-505-01 | 3 mm dia |
| 7-683-140-20 | ⊖ SC 3 x 6 | | |
| 7-685-144-51 | ⊕ P 3 x 5 | | |
| 7-685-145-31 | ⊕ P 3 x 6, self-tapping | | |

Hardware Nomenclature

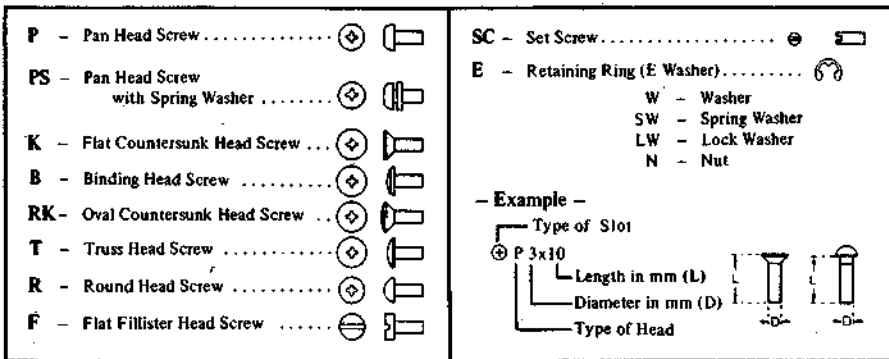

Sony Corporation

© 1972

- 40 -