

TAN-8250

USA Model

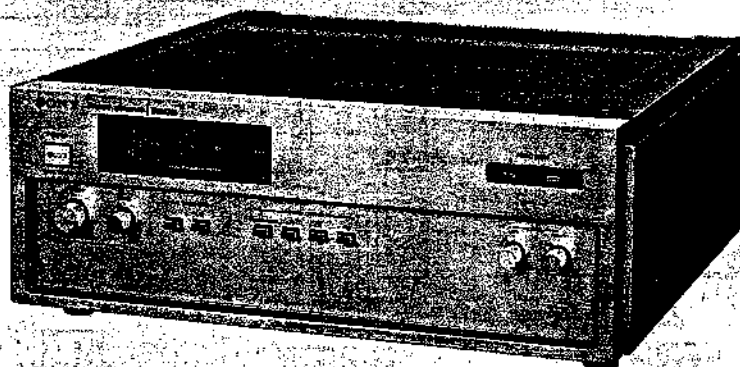

STEREO POWER AMPLIFIER

SPECIFICATIONS

POWER AMP SECTION

Power outputs:

	2 CH	Monaural
Continuous RMS power output: (rated output) (less than 0.2% THD)	180 W + 180 W/8 Ω 250 W + 250 W/4 Ω at 1 kHz, both channels driven simultaneously	LOW 350 W/4 Ω, 470 W/2 Ω HIGH 380 W/16 Ω, 550 W/8 Ω at 1 kHz
	150 W + 150 W/8 Ω 200 W + 200 W/4 Ω at 20 Hz~20 kHz, both channels driven simultaneously	LOW 300 W/4 Ω, 400 W/2 Ω HIGH 350 W/16 Ω, 500 W/8 Ω at 20 Hz~20 kHz
Dynamic power output: (IHF constant power supply method)	370 W/8 Ω 500 W/4 Ω	LOW 370 W/4 Ω, 500 W/2 Ω HIGH 380 W/16 Ω, 550 W/8 Ω

Power bandwidth: (IHF)	5 Hz~50 kHz with 8 Ω load
Harmonic distortion:	0.1% at rated output 0.05% at 1 W output
IM distortion: (60 Hz : 7 kHz = 4:1)	0.1% at rated output 0.05% at 1 W output
Frequency response: (at 1 W output)	20 Hz~100 kHz $^{+0}_{-3}$ dB with NORMAL/ TEST switch set to NORMAL DC~100 kHz $^{+0}_{-1}$ dB with NORMAL/ TEST switch to TEST
Inputs:	Sensitivity: 1.0 V RMS (for rated output) Impedance: 50 kΩ (Two pairs of inputs equipped with LEVEL controls)
Outputs:	Total impedance should be higher than 4 Ω. In 2CH mode minimum speaker impedance is 4 Ω.

In MONO-LOW mode
minimum speaker impedance is 2 Ω.
In MONO-HIGH mode
minimum speaker impedance is 8 Ω.

Residual noise: 1 μW
S/N ratio: 100 dB, weighting network A, short-circuited
Damping factor: 250 (8 Ω, at 1 kHz, at SPEAKER DIRECT terminal)

OPTICAL PEAK PROGRAM METER

Frequency response: 30 Hz~30 kHz $^{+0}_{-3}$ dB
Measuring range: 0~200 W (with METER SENSITIVITY switch set to "x 1/10" 0W~20 W)

GENERAL

System: Phase-linear dc stereo pure-complementary power amplifier
Power requirements: 120 V ac, 60 Hz
Power consumption: 380 W
AC outlet: 1 unswitched 200 W
Dimensions: 440 (w) x 170 (h) x 410 (d) mm
17 $\frac{3}{8}$ (w) x 6 $\frac{3}{4}$ (h) x 16 $\frac{1}{8}$ (d) inches
Weight: 23.3 kg (51 lb 6 oz), net
28.4 kg (62 lb 10 oz), in shipping carton

SONY®

SERVICE MANUAL

BLOCK DIAGRAM

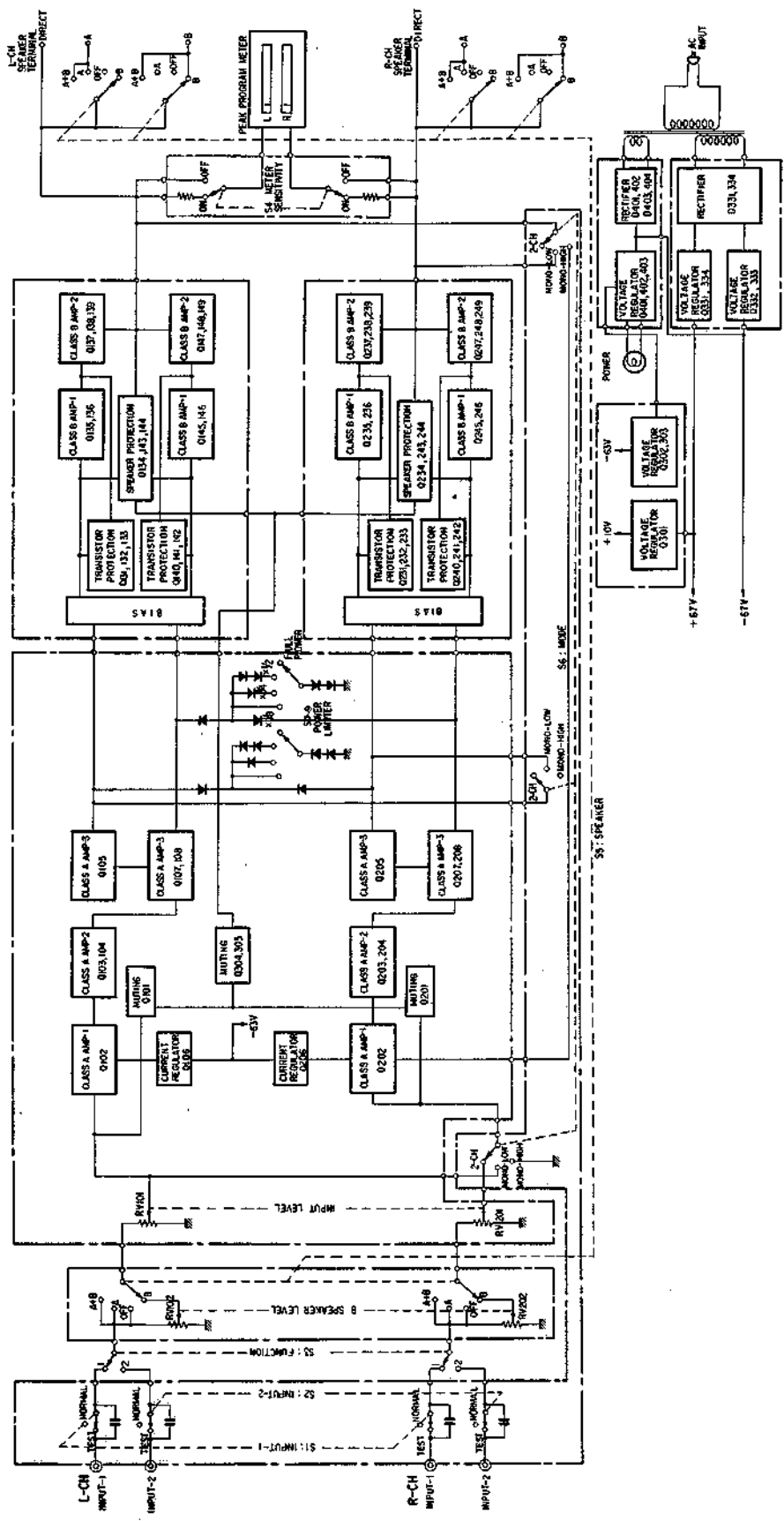

SECTION 1 DISASSEMBLY AND REPLACEMENT

Note: All screws are Phillips type (cross recess type), unless otherwise noted.

1-1. FRONT PANEL REMOVAL

1. Remove the upper panel by taking out the four screws.
2. Remove the screws shown in Fig. 1-1, Fig. 1-2 and Fig. 1-3.

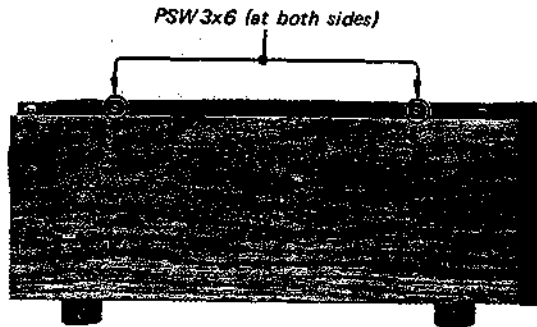

Fig. 1-1. Side panel removal

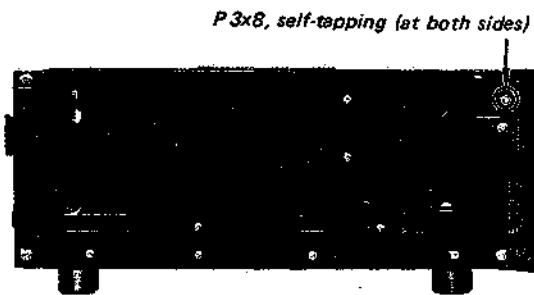

Fig. 1-2. Front panel removal (1)

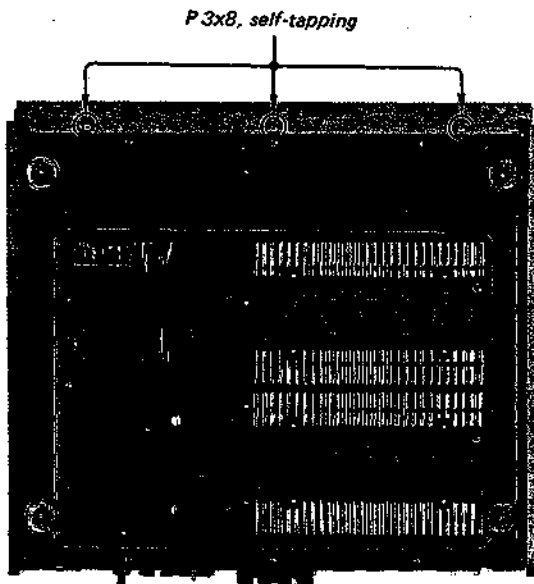

Fig. 1-3. Front panel removal (2)

1-2. FRONT SUBCHASSIS AND REAR PANEL REMOVAL

Remove the screws shown in Fig. 1-4. and Fig. 1-5.

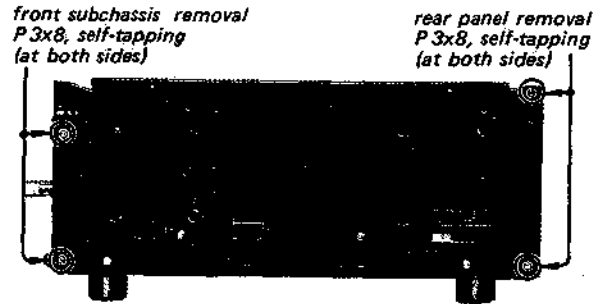

Fig. 1-4. Front subchassis and rear panel removal (1)

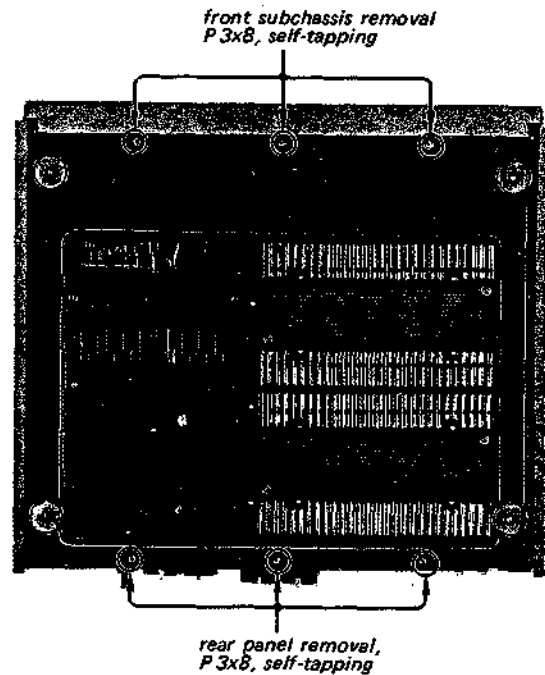

Fig. 1-5. Front subchassis and rear panel removal (2)

1-3. PEAK PROGRAM METER REPLACEMENT

Remove the screws shown in Fig. 1-6 and Fig. 1-7.

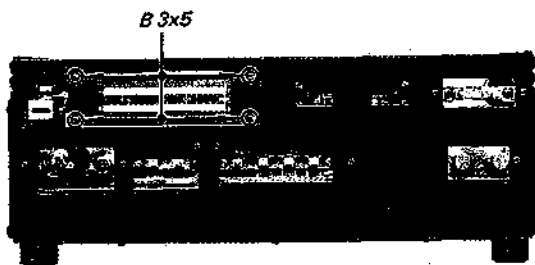

Fig. 1-6. Peak program meter bracket removal

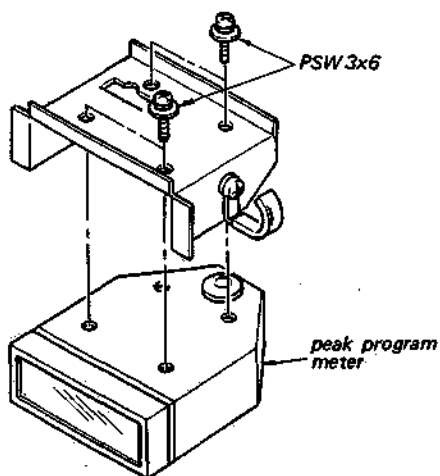

Fig. 1-7. Peak program meter replacement

1-4. CIRCUIT BOARD REMOVAL

Class-B Amp Board Removal

Remove the screws shown in Fig. 1-8 and Fig. 1-9.

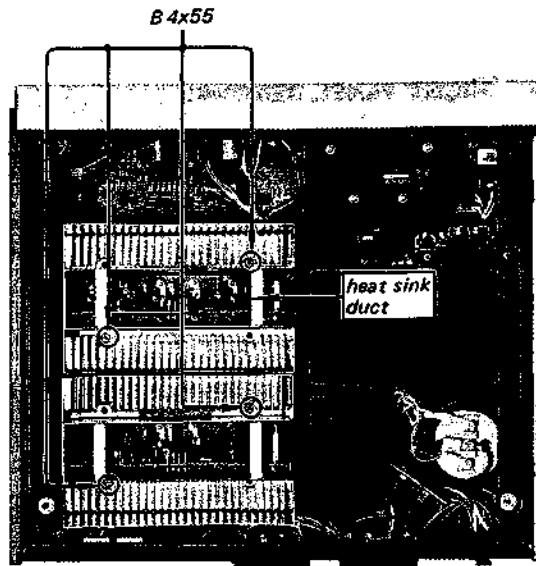

Fig. 1-8. Heat sink duct removal

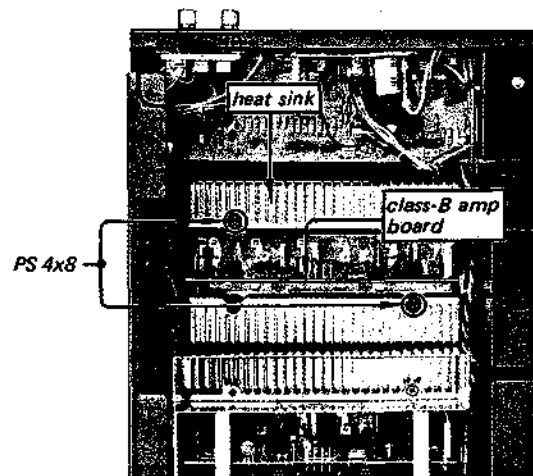
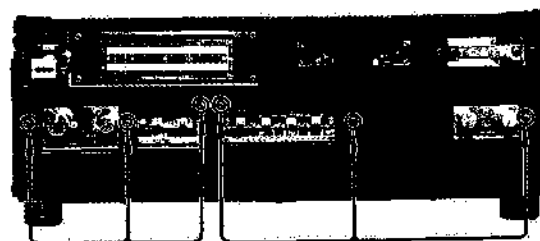

Fig. 1-9. Heat sink and class-B amp board removal

Class-A Amp Board and Meter Board Removal

See Fig. 1-10.



meter board removal, B 3x5 class-A amp board removal, B 3x5

Fig. 1-10. Class-A amp board and meter board removal

Regulator Board Removal

Remove the two nylon rivets shown in Fig. 1-11.

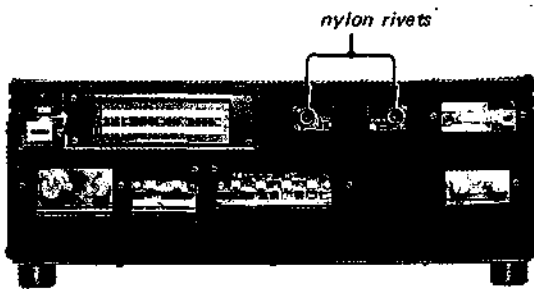

Fig. 1-11. Regulator board removal

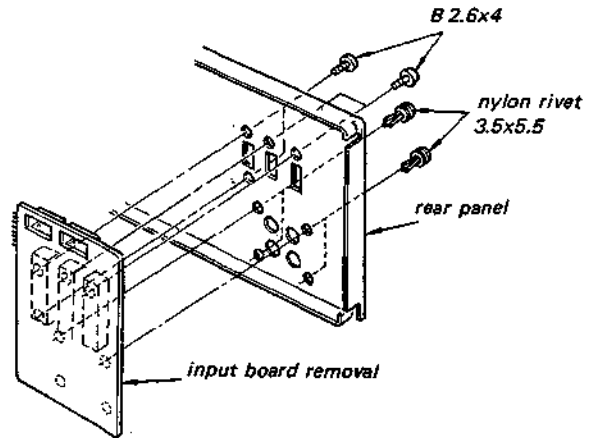

Fig. 1-13. Input board removal

Power Supply Board Removal

Remove the two screws shown in Fig. 1-12.

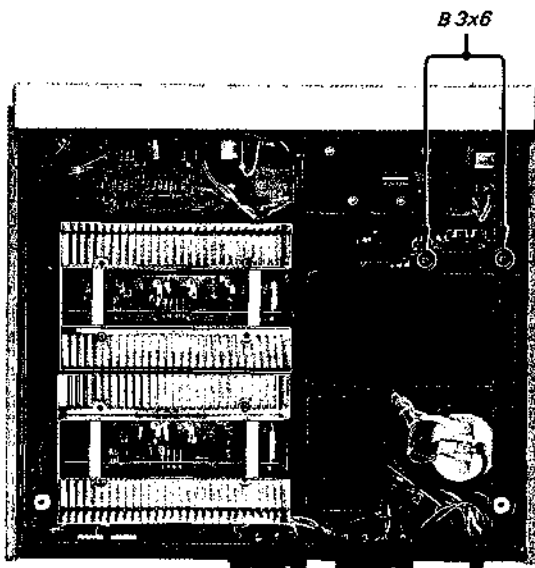

Fig. 1-12. Power supply board removal

Input Board Removal

1. Remove the rear panel as described in Procedure 1-2.
2. Remove the screws and nylon rivets shown in Fig. 1-13.

1-5. POWER TRANSISTOR REPLACEMENT

Remove the screws shown in Fig. 1-14 and Fig. 1-15.

Note: When replacing the power transistor, apply a coating of a heat-transferring grease to both sides of the mica insulator as shown in Fig. 1-15. Any excess grease squeezed out when the screws (B 3x12) are tightened should be wiped off with a clean cloth. This prevents it from accumulating conductive dust particles that might eventually cause a short.

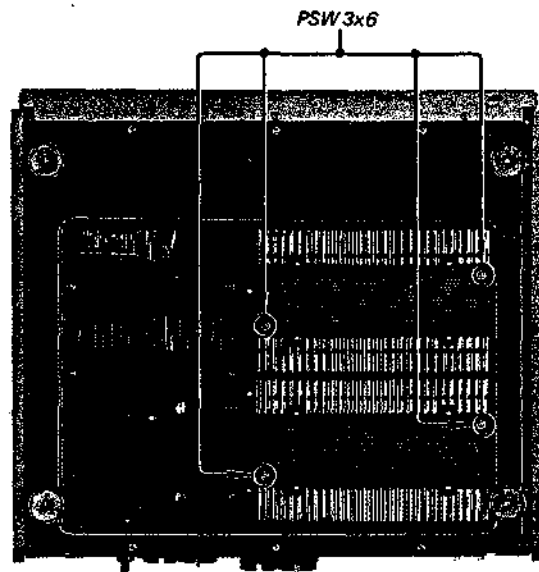

Fig. 1-14. Bottom plate cover removal

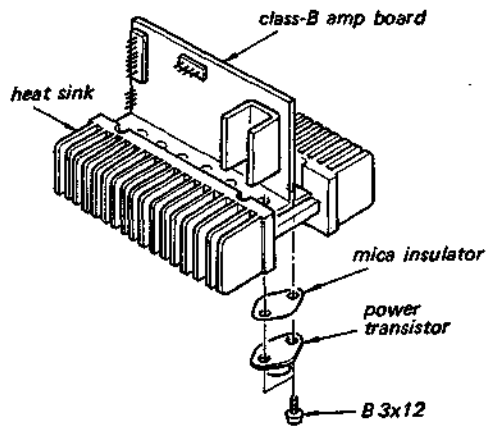

Fig. 1-15. Power transistor replacement

1-6. CHASSIS LAYOUT

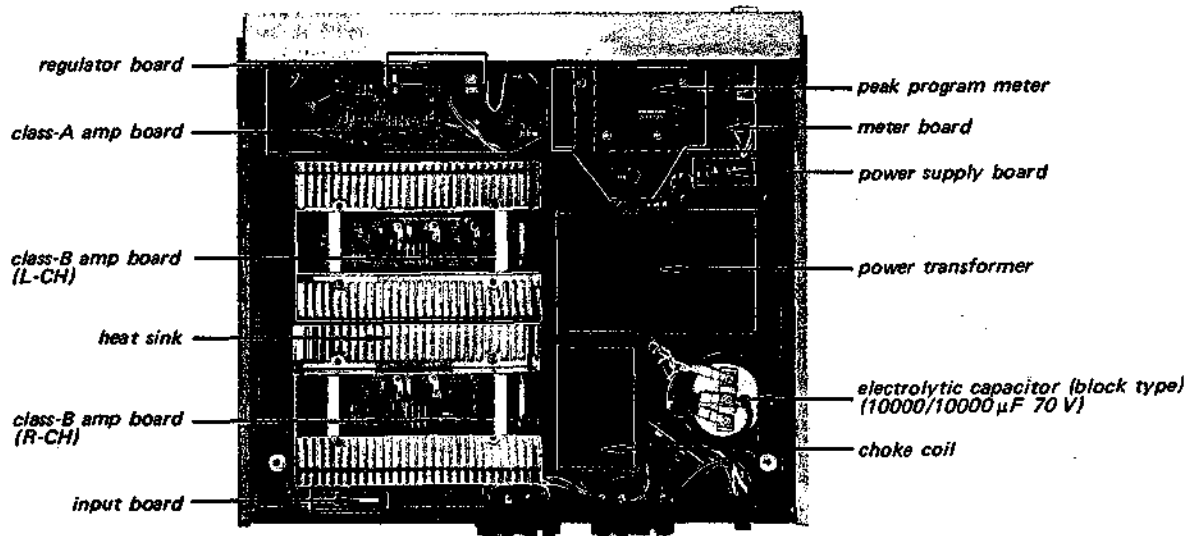

Fig. 1-16. Chassis layout - top view -

SECTION 2 ADJUSTMENTS

Note: Allow about five minutes for warm-up.

2-1. POWER VOLTAGE ADJUSTMENT

Regulator Board

CAUTION

Never short the test terminal pin to ground, because the voltage difference between the each pin and ground is 70~76 V in absolute value.

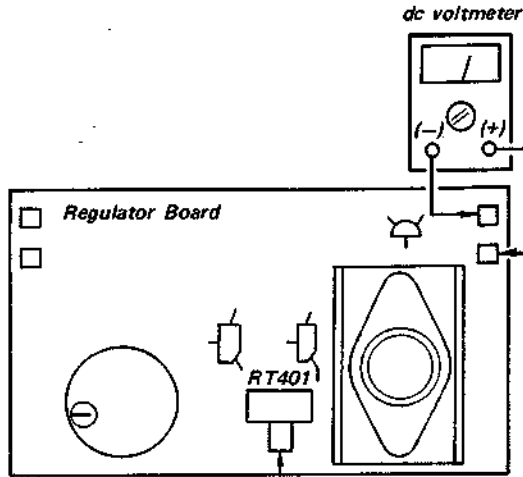

Adjust RT401 for 8 V reading on the meter.

Fig. 2-1.

Class-A Amp Board

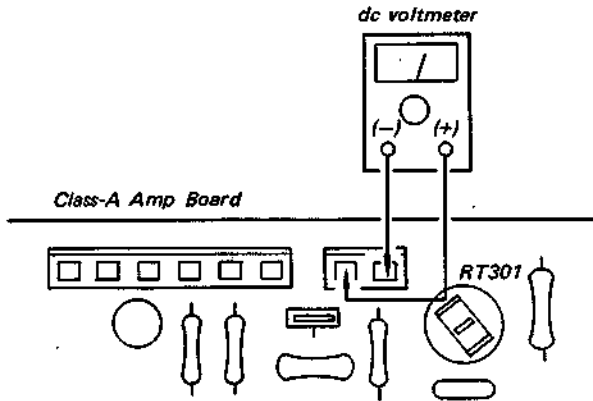

Adjust RT301 for 65 V reading on the meter.

Fig. 2-2.

Note: If this adjustment has not been made correctly, enough output will not be obtained.

Power Supply Board

Note: Always connect the 8 Ω load across the SPEAKER OUT "A" and feed a 1 kHz signal to TAN-8250 during the adjustment.

Test setup:

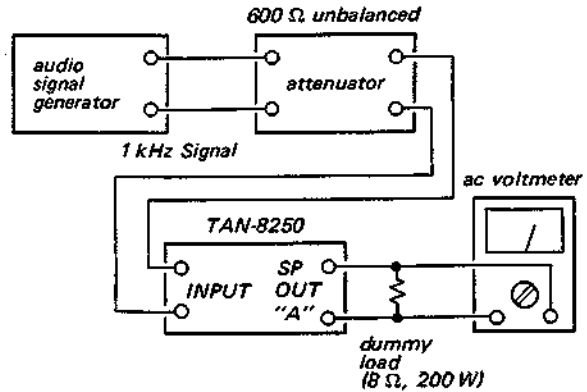

Fig. 2-3.

Preparation

1. Set the TAN-8250 switches and control as follows:

SPEAKER switch A
 POWER LIMITER switch ... FULL POWER
 INPUT switch NORMAL
 MODE switch 2CH
 LEVEL control fully clockwise

2. Feed a 1 kHz signal to TAN-8250, and adjust the attenuator for 50 W (20.0 V) on the meter.
3. Connect the dc voltmeter across terminal pins of capacitor as shown in Fig. 2-4.
4. With the 1 kHz signal fed, adjust RT331 (See Fig. 2-5.) for 65 V reading (See Fig. 2-4.) on the meter, respectively.

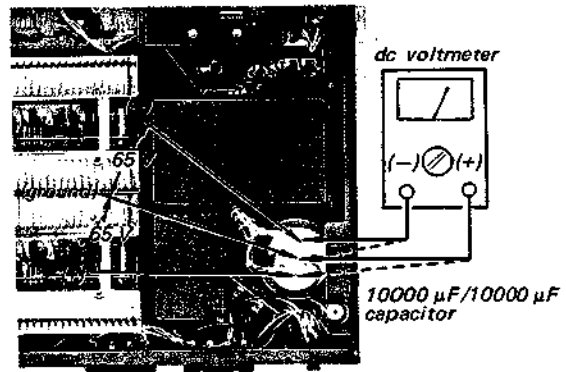
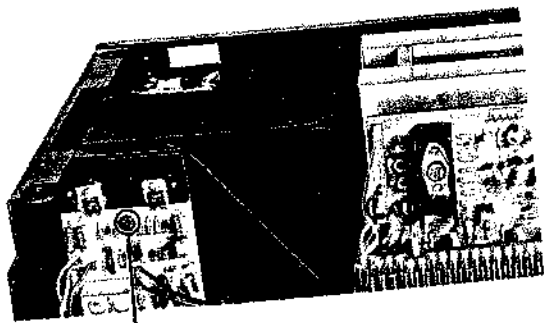

Fig. 2-4.



RT331

Fig. 2-5.

2-2. DC BALANCE ADJUSTMENT

Preparation:

1. Set the TAN-8250 switches as follows:
 SPEAKER switch A
 MODE switch 2CH
2. Connect the dc voltmeter across the SPEAKER OUT "A".

Procedure:

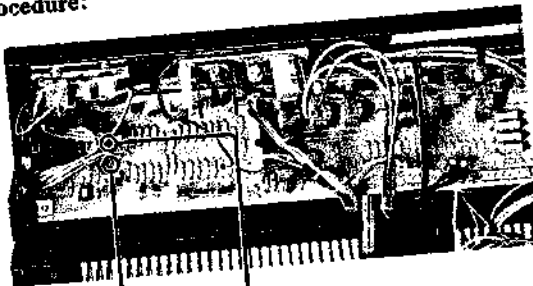

RT201 (R-CH) RT101 (L-CH)

Adjust RT101 and RT201 for 0 V reading on the meter.

Fig. 2-6.

Note: The dc balance and dc bias adjustments should be alternately repeated two or three times.

2-3. DC BIAS ADJUSTMENT

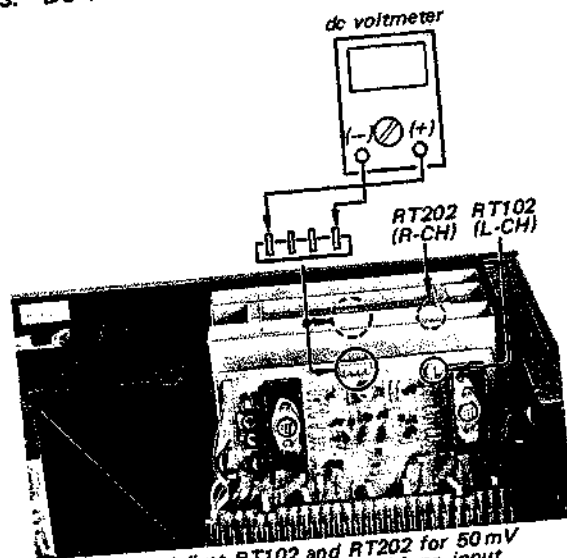

Adjust RT102 and RT202 for 50 mV reading on the meter with no input signal.

Fig. 2-7.

Note: The dc balance and dc bias adjustments should be alternately repeated two or three times.

2-4. PEAK PROGRAM METER ADJUSTMENT AND CHECK

Test setup:

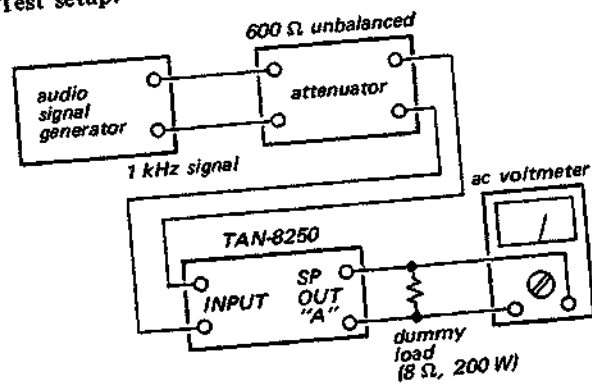

Fig. 2-8.

Preparation:

Set the TAN-8250 switches as follows:

SPEAKER switch A
 POWER LIMITER switch ... FULL POWER
 METER SENSITIVITY
 switch x1
 MODE switch 2CH
 INPUT switch NORMAL

Procedure:

1. Feed a 1 kHz signal to INPUT jack and adjust the attenuator for 100 W (28.3 V) reading on the ac voltmeter.
2. Adjust RT181 and RT281 (See Fig. 2-9.) so that the peak program meter reads 100 W.

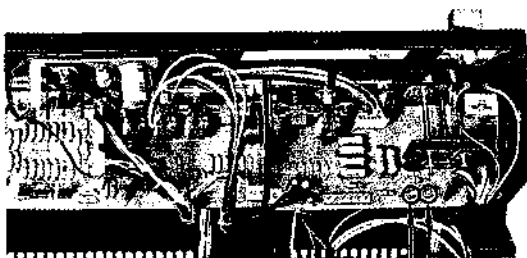
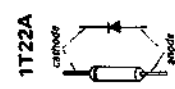
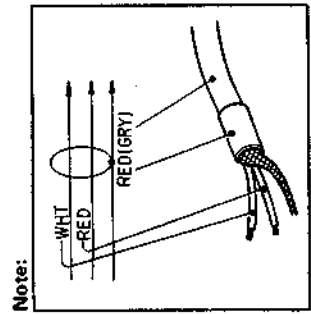
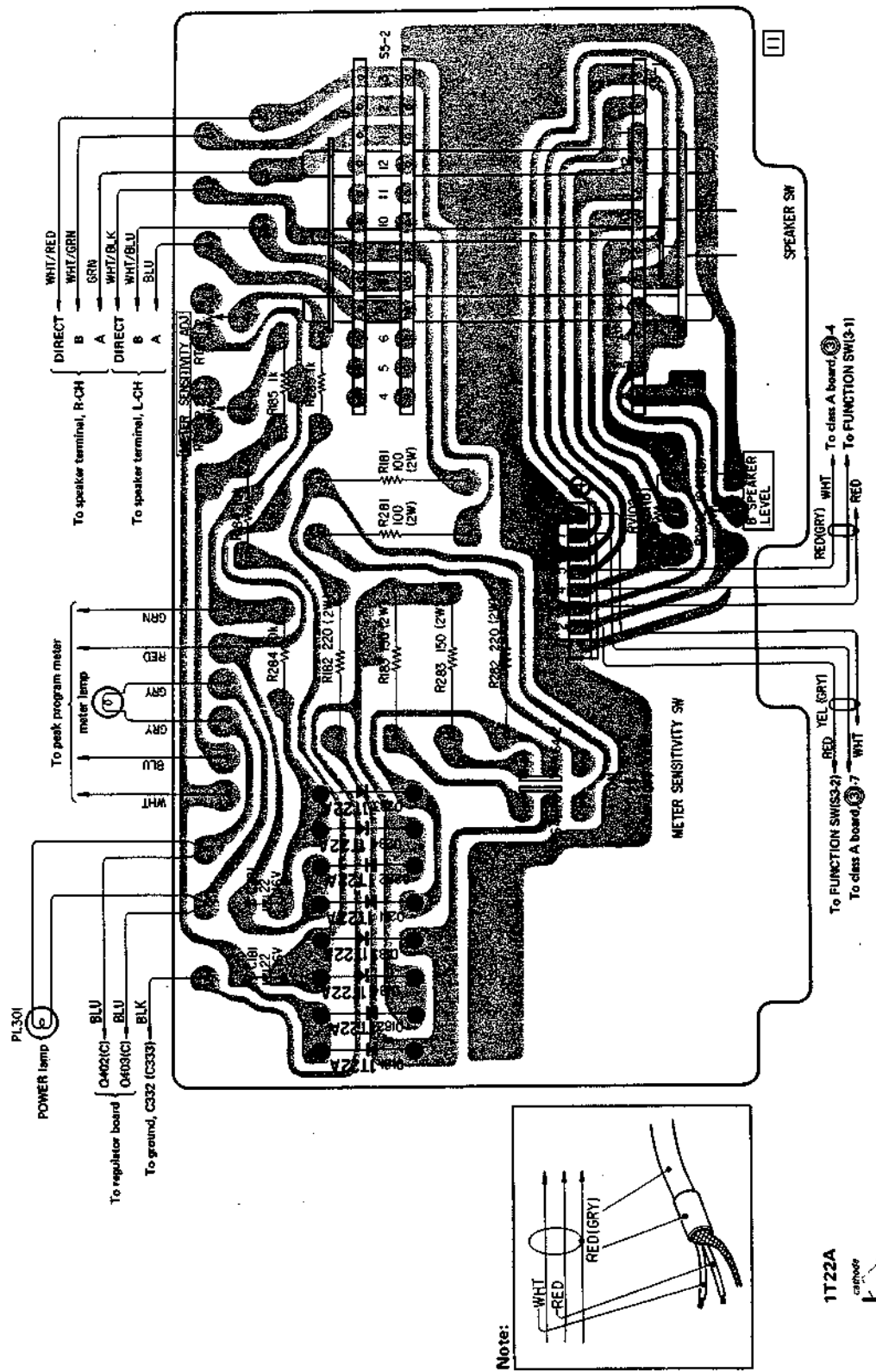

Fig. 2-9.

3. Decrease the output of attenuator 10 dB, and confirm that the peak program meter reads 10 W.
4. Change the METER SENSITIVITY switch to "x1/10", and confirm that the peak program meter reads 100 W.
5. Decrease the output of attenuator 10 dB, and confirm that the peak program meter reads 10 W.
6. Change the METER SENSITIVITY switch to "x1", and confirm that the peak program meter reads 1 W.

SECTION 3
DIAGRAMS

3-1. MOUNTING DIAGRAM – Meter Board –
– Conductor Side –



3-2. MOUNTING DIAGRAM – Input Board –

– Conductor Side –

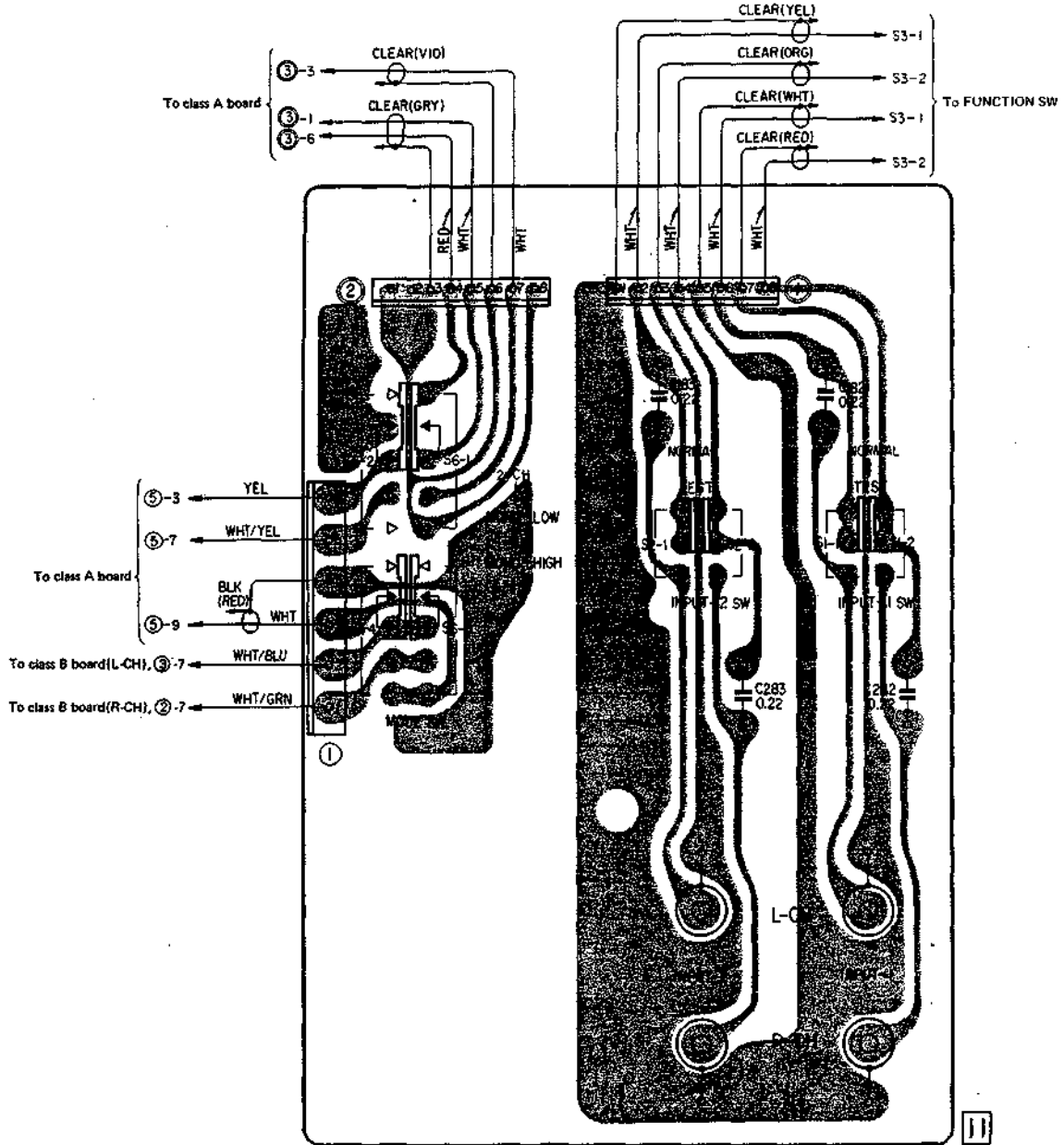

Note:

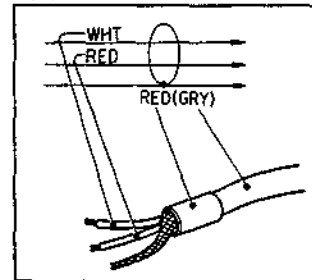

3-3. MOUNTING DIAGRAM – Power Supply Board –

– Conductor Side –

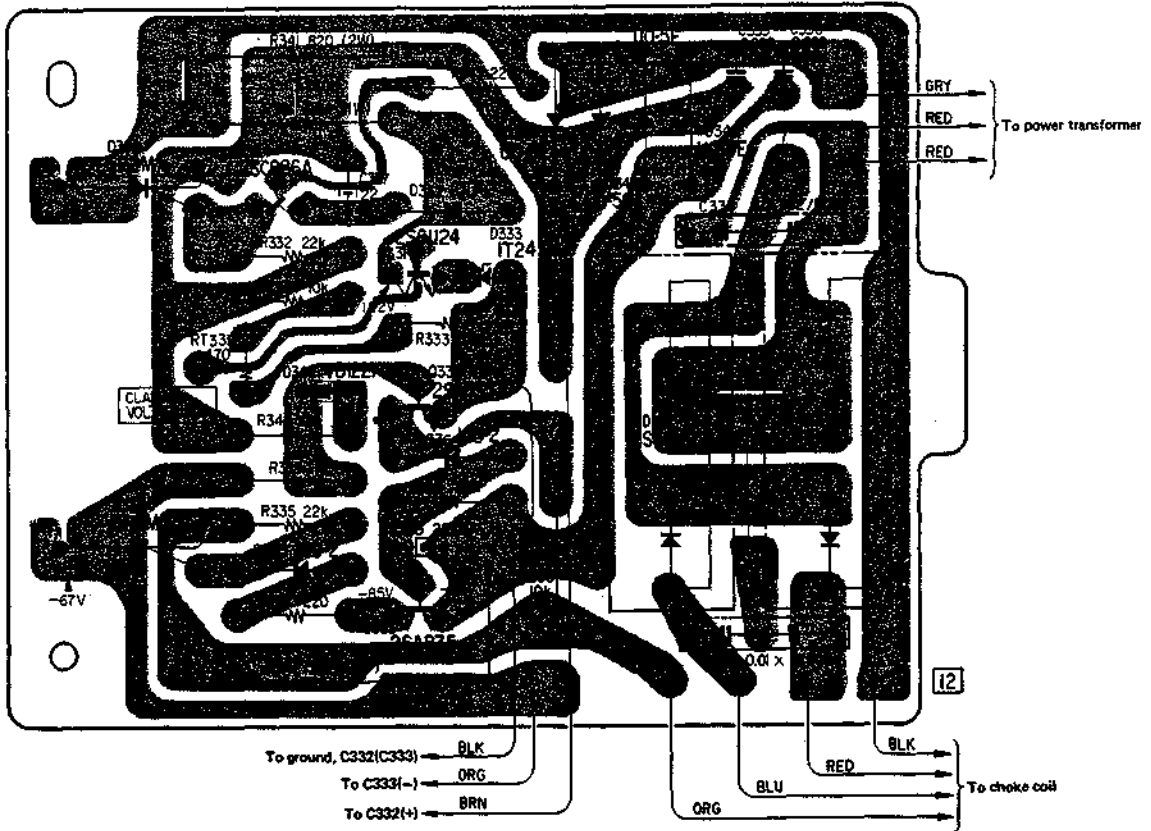

Parts	Location
Q	Q334 Q331 Q332 Q333
D	D338 D339 D344 D335 D332 D333 D336 D340 D342 D343 D341 D331 D334

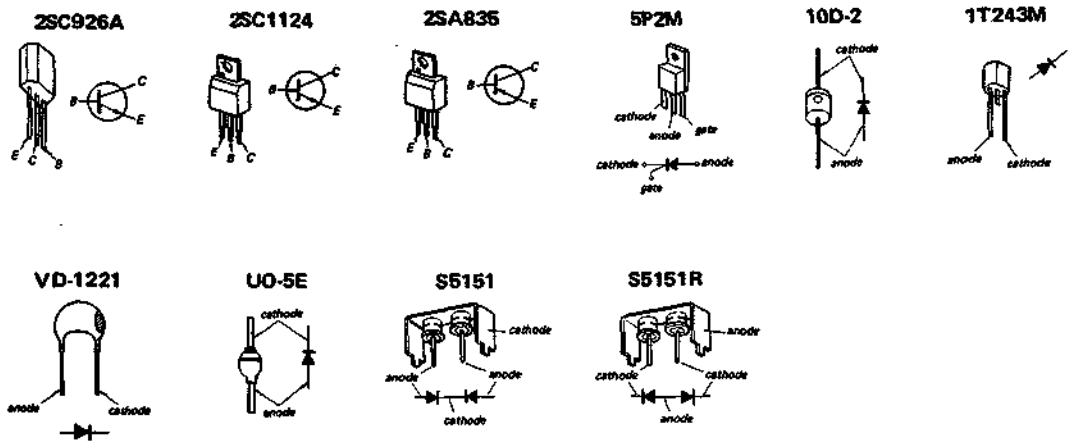

TAN-8250 TAN-8250

3-4. MOUNTING DIAGRAM — Regulator Board —

— Conductor Side —

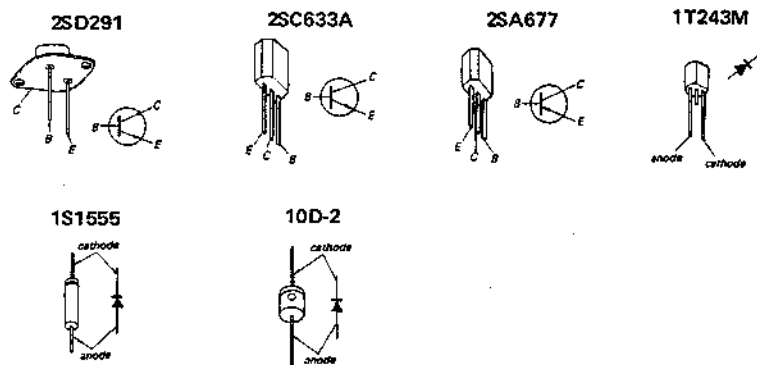
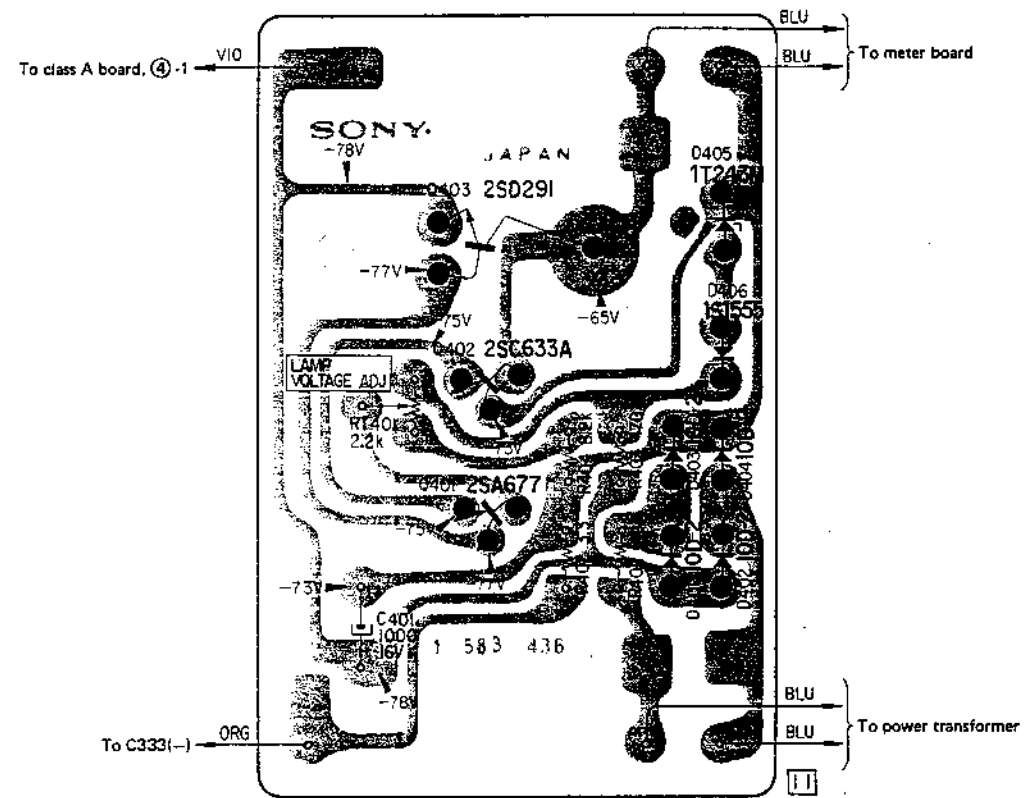

3-5. MOUNTING DIAGRAM — Class-B Amp Board —

— Conductor Side —

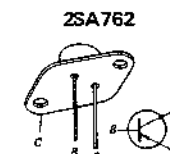
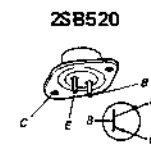
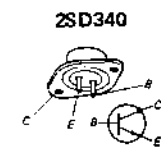
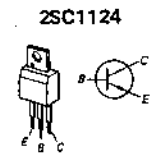
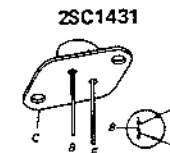
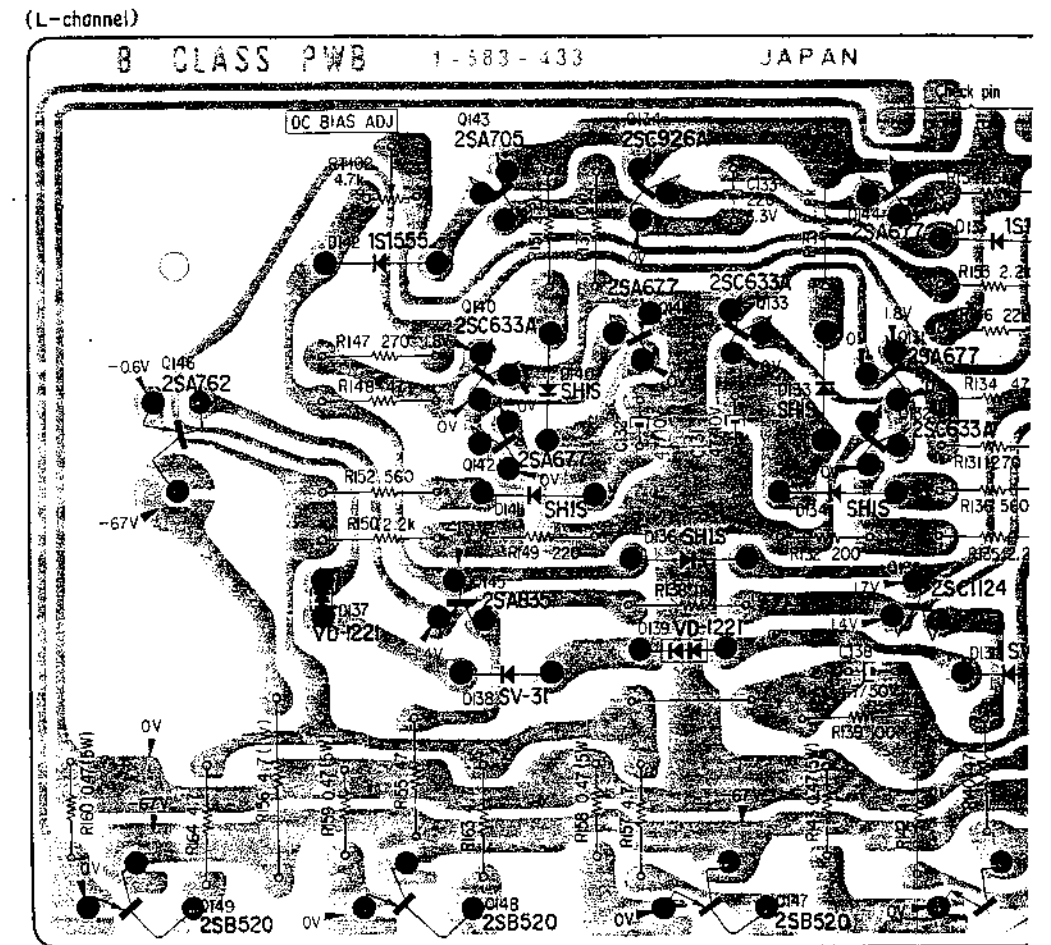

Parts Location

	Q146	Q143 Q140 Q142 Q145	Q134 Q141	Q133	Q144 Q131 Q132	Q135	Q137
Q	Q149	Q148		Q147			
D		D142	D140 D141	D136 D139	D133 D134		D131

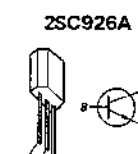
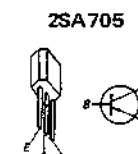
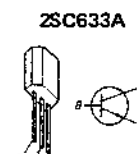
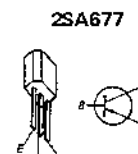
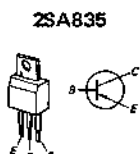

3-5. MOUNTING DIAGRAM - Class-B Amp Board -

- Conductor Side -

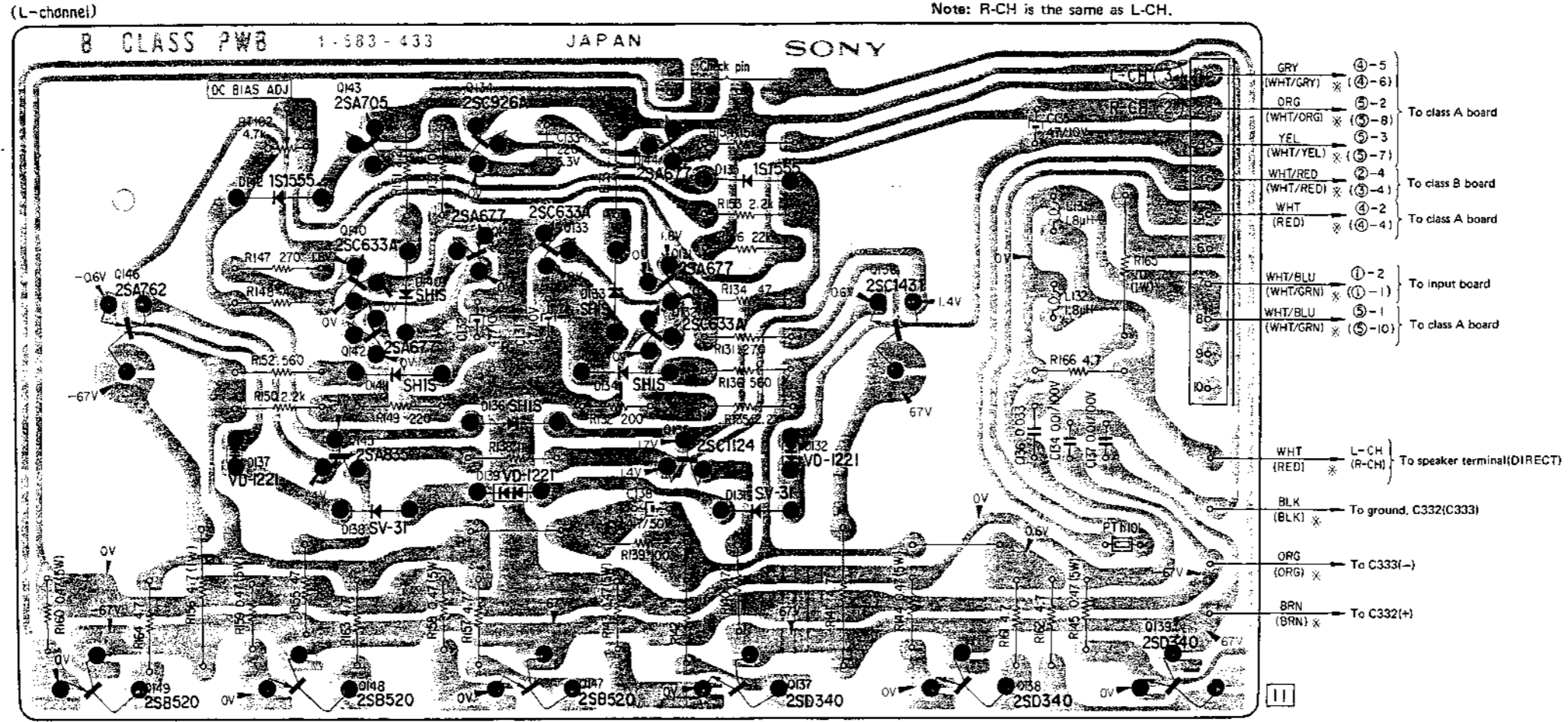

Note: The reference numbers in R-channel start from 200's.
* mark shows the lead wire of R channel.

3-6. MOUNTING DIAGRAM — Class-A Amp Board —
— Conductor Side —

2SC633A
2SC634
2SC926A

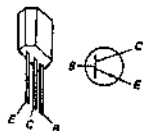

1S1555
1T22A

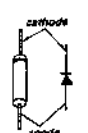

2SA706

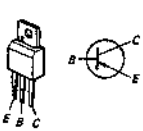

1T243M



2SA835

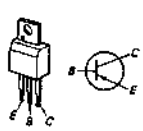

VD-1221

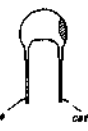

2SC1124

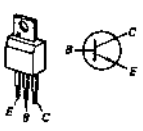

VO-9C

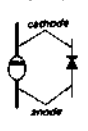

2SA705

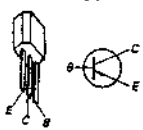

2SA639S

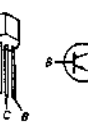

2SK58

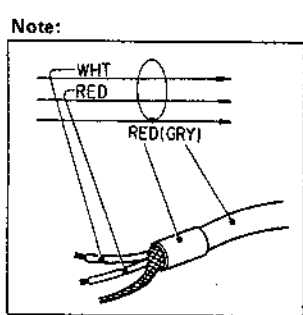
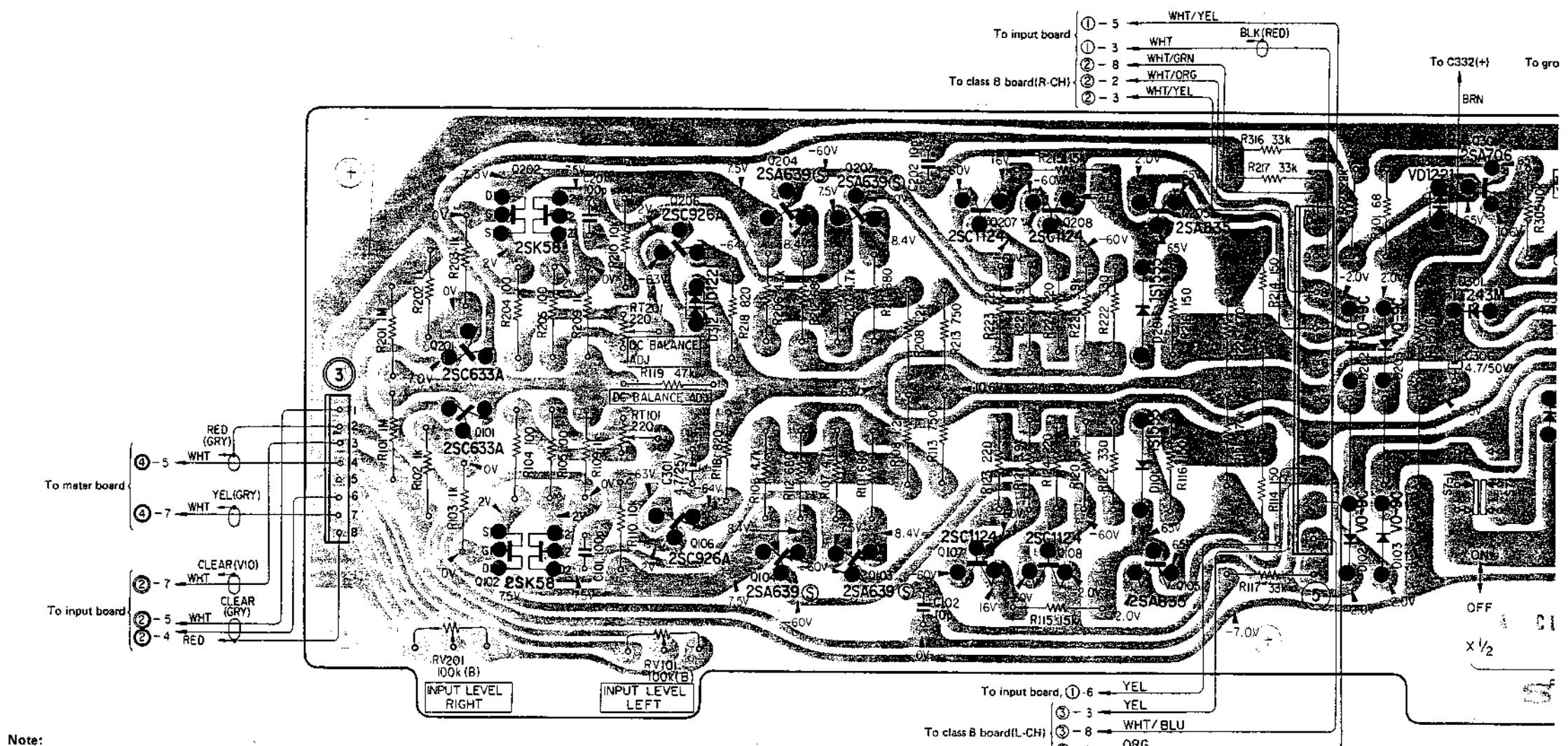
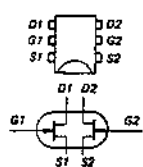

Parts Location

Q	Q201	Q202	Q206	Q204	Q203	Q207	Q208	Q205	Q301
	Q101	Q102	Q106	Q104	Q103	Q107	Q108	Q105	
D			D312					D201 D101	D202 D203 D102 D103 D302 D301 D302
ADJ				RT201 RT101					

TAN-8250 TAN-8250

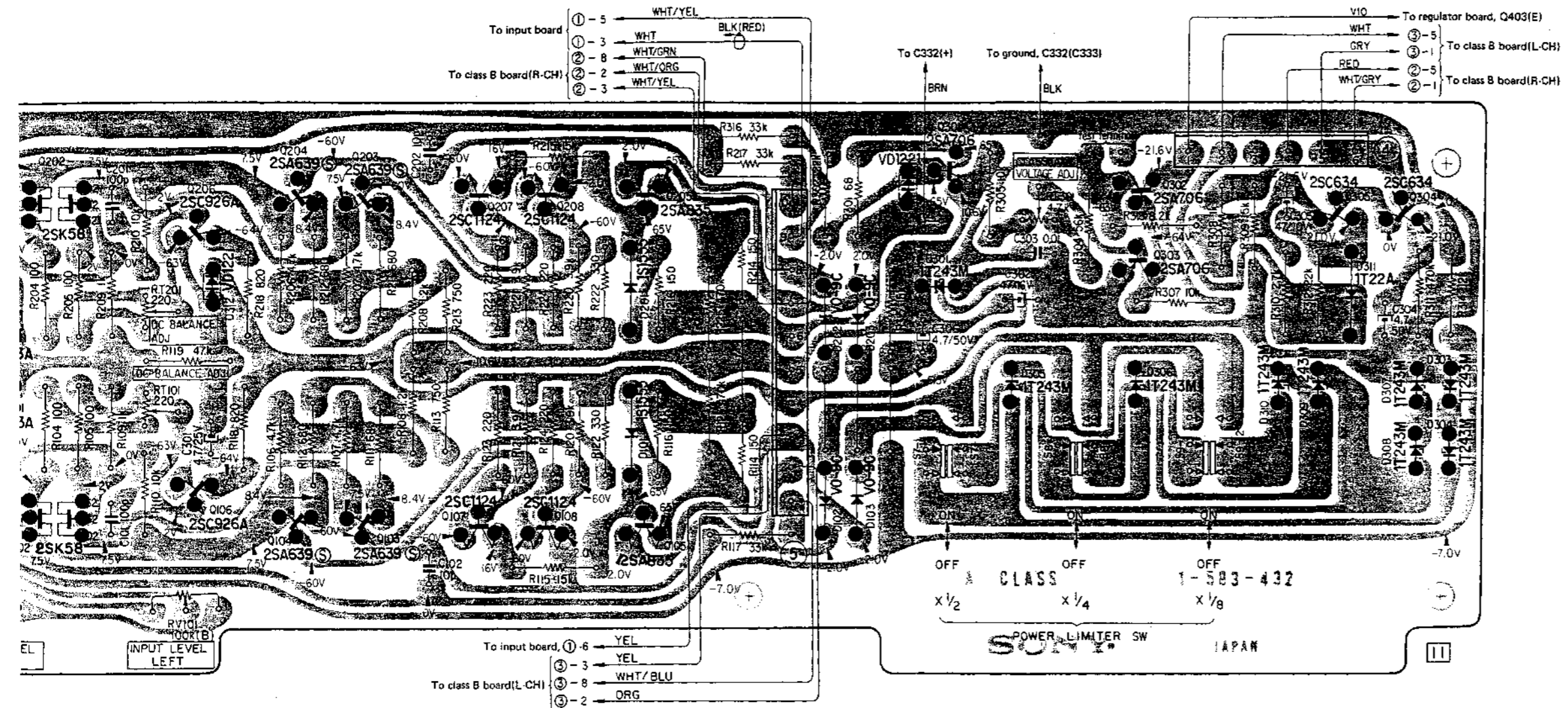

Q202	Q206	Q204	Q203	Q207	Q208	Q205	Q301	Q302	Q305	Q304							
Q102	Q106	Q104	Q103	Q107	Q108	Q105		Q303									
	D312			D201			D202	D203	D302	D301	D305	D306	D310	D309	D311	D307	D303
				D101			D102	D103								D308	D304
RT201																	RT301
RT101																	

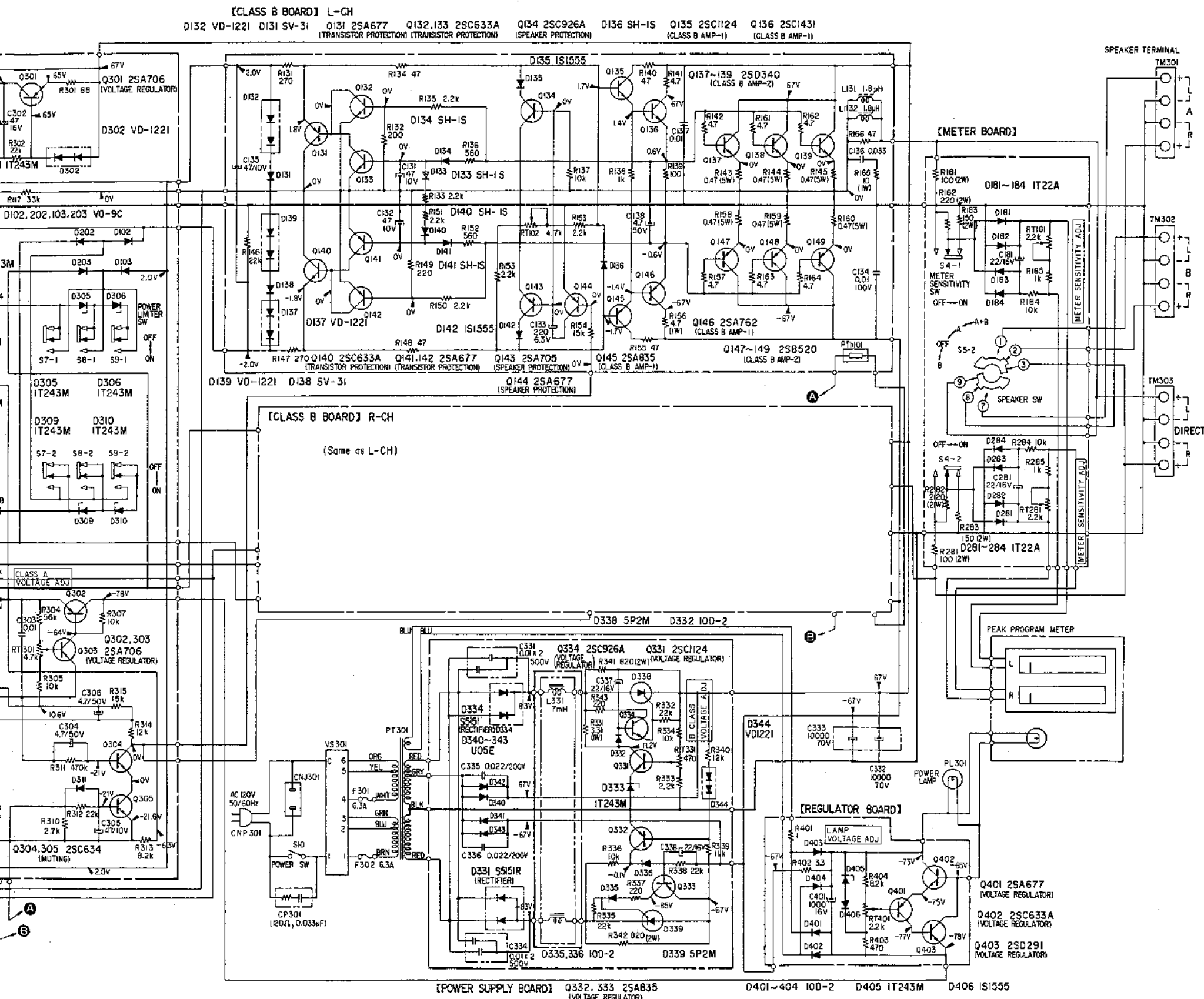

Ref. No.	Description	Position
S1	INPUT-1 SW (NORMAL-TEST)	NORMAL
S2	INPUT-2 SW (NORMAL-TEST)	NORMAL
S3	FUNCTION SW (INPUT-1 - INPUT-2)	INPUT-1
S4	METER SENSITIVITY SW	ON
S5	SPEAKER SW (A+B-A-OFF-B)	B
S6	MODE SW (2-CH-MONO LOW-MONO HIGH)	2-CH
S7	POWER LIMITER (1/8) SW	OFF
S8	POWER LIMITER (1/4) SW	OFF
S9	POWER LIMITER (1/2) SW	OFF
S10	POWER SW	OFF

Note:
 All resistance values are in ohms. k=1,000 M=1,000 k
 All capacitance values are in μF except as indicated with p, which means μF .
 All voltages are dc measured with a VOM which has an input impedance of 20 k ohms/volt. No signal in.
 Voltage variations may be noted because of normal production tolerances.

SECTION 4
EXPLODED VIEWS

(1)

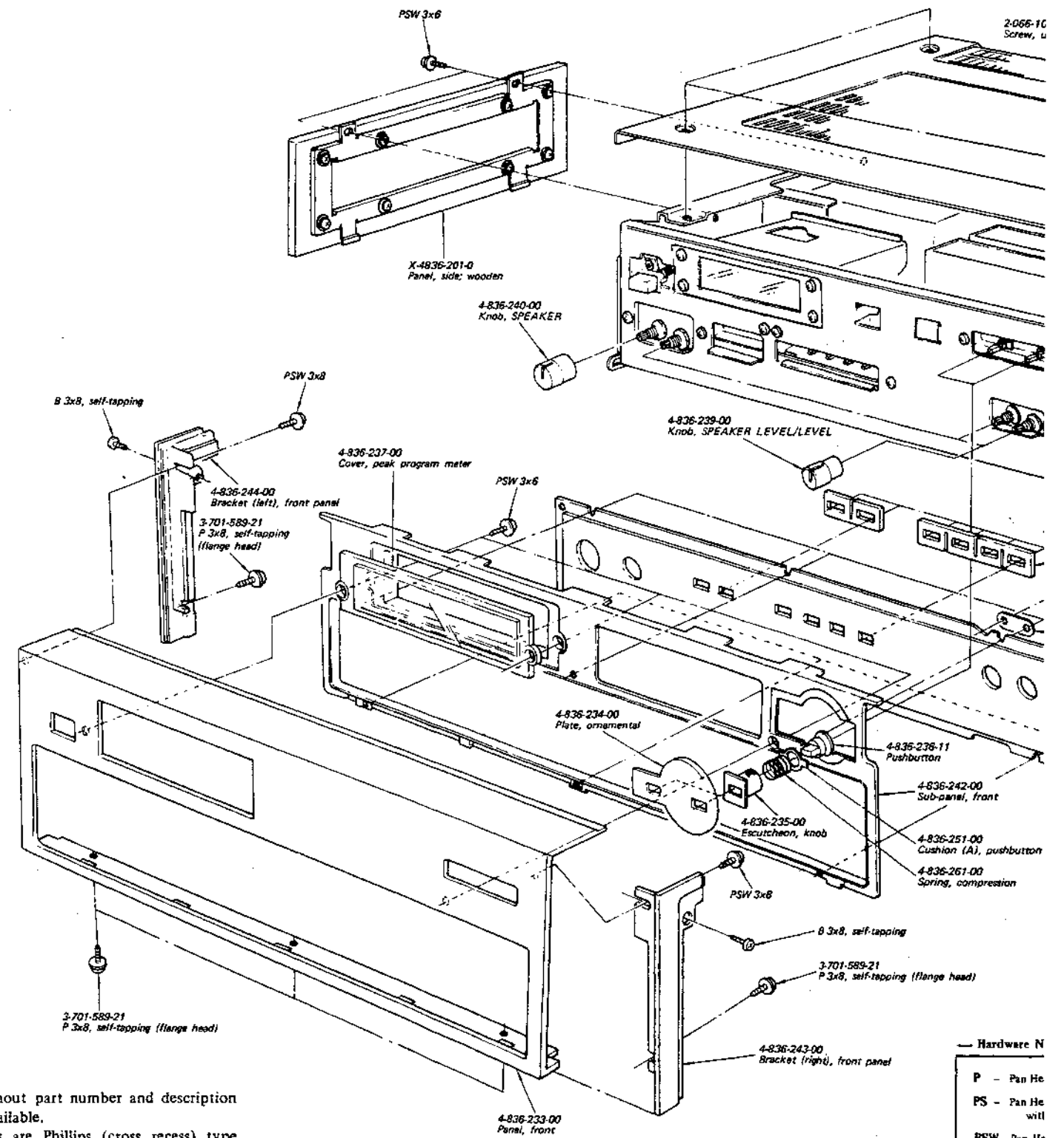

Note: ○ Items without part number and description are not available.
○ All screws are Phillips (cross recess) type unless otherwise noted.
(-) = slotted head

— Hardware N

P	- Pan He
PS	- Pan He will
PSW	- Pan He War
B	- Bindin

MEMO

TAN-8250 TAN-8250

SECTION 4 EXPLODED VIEWS

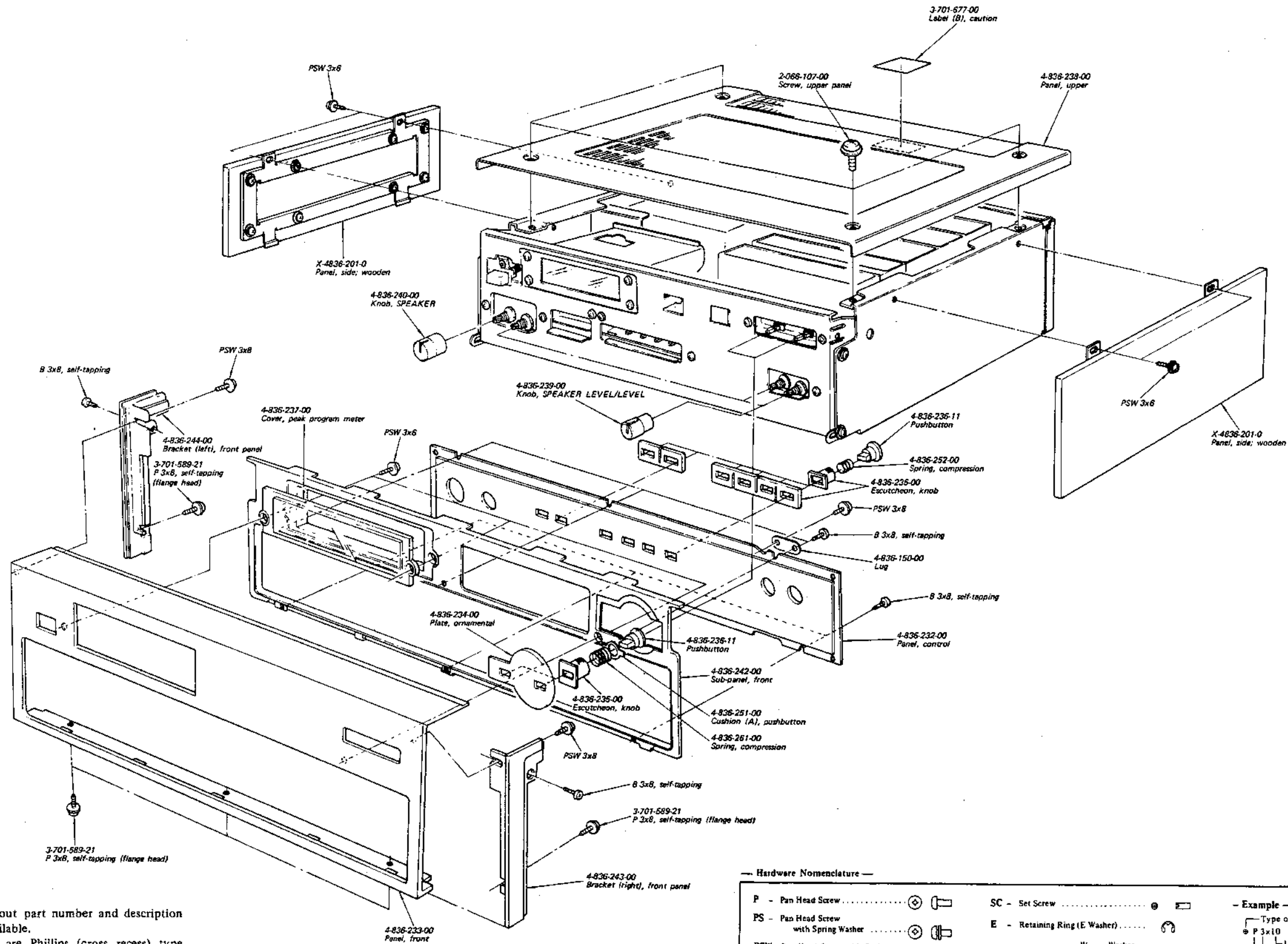

Hardware Nomenclature

P - Pan Head Screw	SC - Set Screw	- Example - Type of Slot P 3x10 Length in mm (L) Diameter in mm (D) Type of Head
PS - Pan Head Screw with Spring Washer	E - Retaining Ring (E Washer)	
PSW - Pan Head Screw with Spring Washer and Washer	W - Washer	
B - Binding Head Screw	SW - Spring Washer	
	LW - Lock Washer	
	N - Nut	

Note: ○ Items without part number and description are not available.
 ○ All screws are Phillips (cross recess) type unless otherwise noted.
 (-) = slotted head

TAN-8250 TAN-8250

(2)

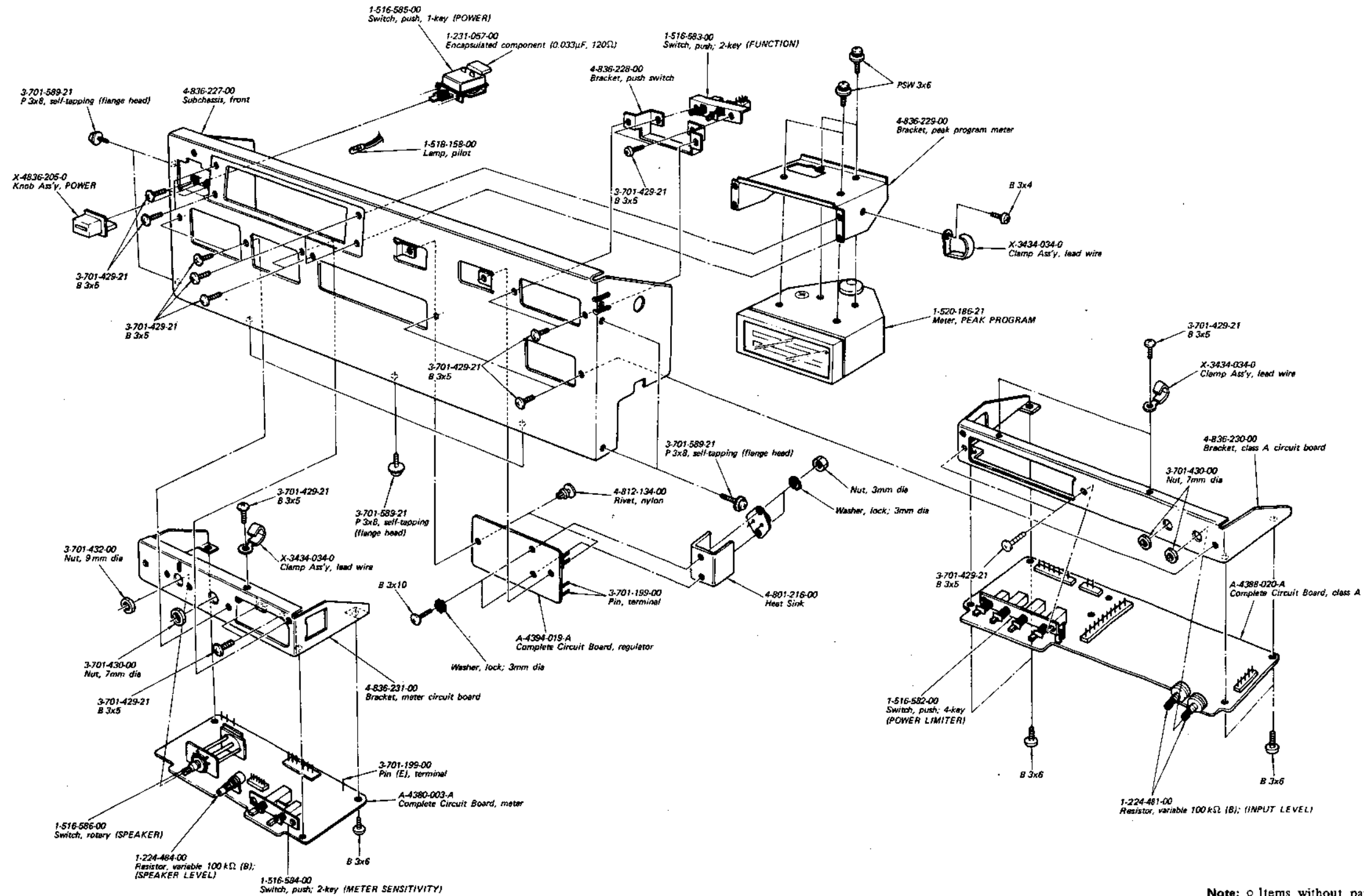

Note: ○ Items without part number and description are not available.
 ○ All screws are Phillips (cross recess) type unless otherwise noted.
 (-) = slotted head

TAN-8250 TAN-8250

(3)

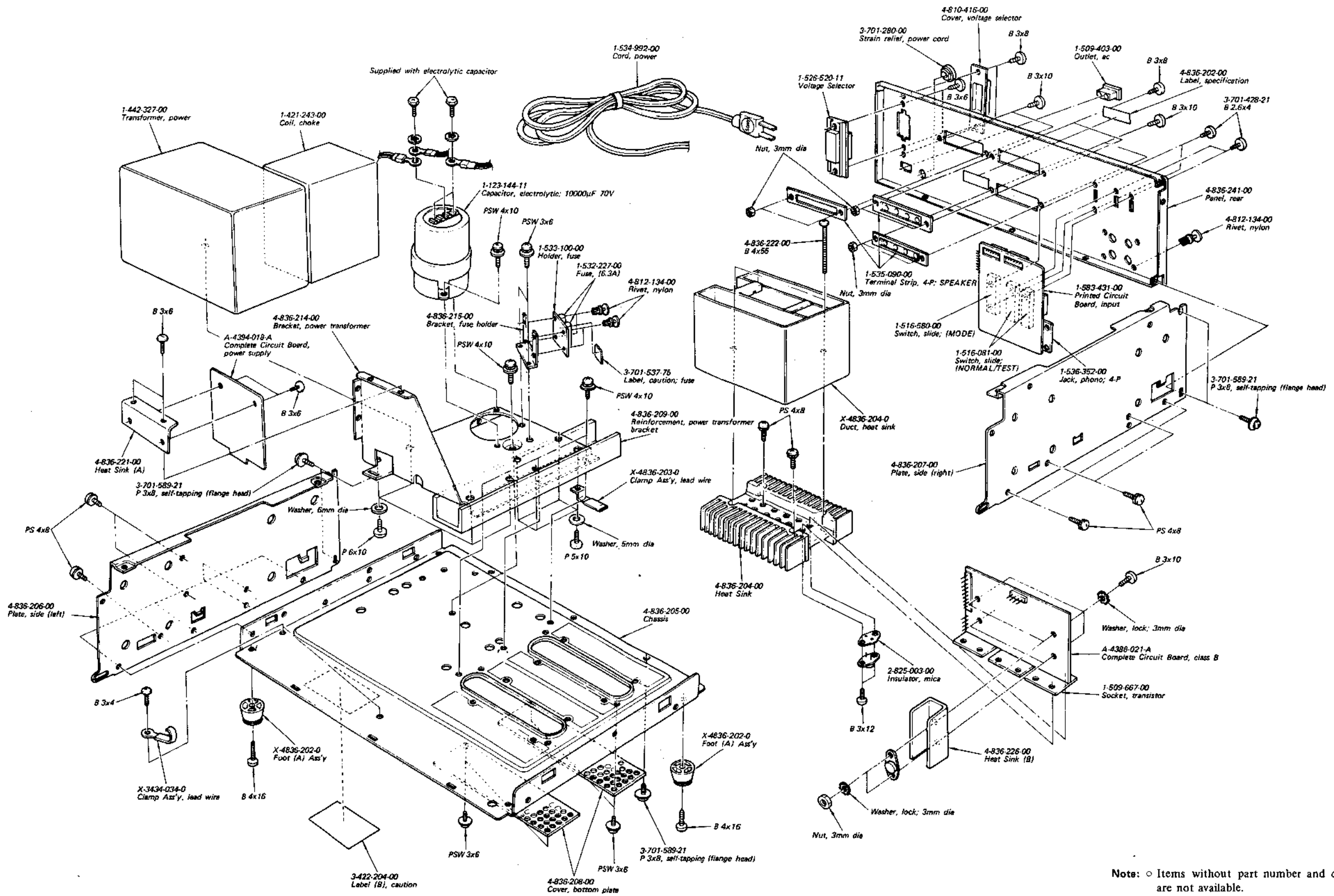

SECTION 5
ELECTRICAL PARTS LIST

<u>Ref. No.</u>	<u>Part No.</u>	<u>Description</u>	<u>Ref. No.</u>	<u>Part No.</u>	<u>Description</u>
CIRCUIT BOARDS					
A-4380-003-A		Meter, complete	Q331		Transistor 2SC1124
A-4388-020-A		A Class, complete	Q332,Q333		Transistor 2SA835
A-4388-021-A		B Class, complete	Q334		Transistor 2SC926A
A-4394-018-A		Power Supply, complete	Q401		Transistor 2SA677
A-4394-019-A		Regulator, complete	Q402		Transistor 2SC633A
			Q403		Transistor 2SD291
1-583-431-00		Input	D101~D103 (D201~D203)		Diode 1S1555
SEMICONDUCTORS					
Q101(Q201)		Transistor 2SC633A	D131(D231)		Diode SV-31
Q102(Q202)		FET 2SK58	D132(D232)		Diode VD-1221
Q103(Q203)		Transistor 2SA639S	D133(D233)		Diode SH-1S
Q104(Q204)		Transistor 2SA639S	D134(D234)		Diode SH-1S
Q105(Q205)		Transistor 2SA835	D135(D235)		Diode 1S1555
Q106(Q206)		Transistor 2SC926A	D136(D236)		Diode SH-1S
Q107(Q207)		Transistor 2SC1124	D137(D237)		Diode VD-1221
Q108(Q208)		Transistor 2SC1124	D138(D238)		Diode SV-31
Q131(Q231)		Transistor 2SA677	D139(D239)		Diode VD-1221
Q132(Q232)		Transistor 2SC633A	D140(D240)		Diode SH-1S
Q133(Q233)		Transistor 2SC633A	D141(D241)		Diode SH-1S
Q134(Q234)		Transistor 2SC926A	D142(D242)		Diode 1S1555
Q135(Q235)		Transistor 2SC1124	D181~D184 (D281~D284)		Diode 1T22A
Q136(Q236)		Transistor 2SC1431	D301		Diode 1T243M
Q137~Q139 (Q237~Q239)		Transistor 2SD340	D302		Diode VD-1221
Q140(Q240)		Transistor 2SC633A	D303~D310		Diode 1T243M
Q141(Q241)		Transistor 2SA677	D311		Diode 1T22A
Q142(Q242)		Transistor 2SA677	D312		Diode VD-1221
Q143(Q243)		Transistor 2SA705	D331		Diode S5151
Q144(Q244)		Transistor 2SA677	D332		Diode 10D-2
Q145(Q245)		Transistor 2SA835	D333		Diode 1T243M
Q146(Q246)		Transistor 2SA762	D334		Diode S5151R
Q147~Q149 (Q247~Q249)		Transistor 2SB520	D335		Diode 10D-2
Q301~Q303		Transistor 2SA706	D336		Diode 10D-2
Q304~Q305		Transistor 2SC634A	D337		-----
			D338		Diode 5P2M
			D339		Diode 5P2M
			D340~D343		Diode UO-5E
			D344		Diode VD-1221

Ref. No.	Part No.	Description
D401~D404		Diode 10D-2
D405		Diode 1T243M
D406		Diode 1S1555

Pth301, Pth302	1-800-340-00	Posistor
-------------------	--------------	----------

CAPACITORS

Capacitors listed here are electrolytic type unless otherwise specified and in μF except as indicated with p (p means $\mu\mu$).

C101(C201)	1-102-973-11	100p	50V	ceramic
C102(C202)	1-102-947-11	10p	50V	ceramic
C131(C231)	1-121-352-11	47	10V	
C132(C232)	1-121-352-11	47	10V	
C133(C233)	1-121-419-11	220	6.3V	
C134(C234)	1-108-657-12	0.01	100V	mylar
C135(C235)	1-121-352-11	47	10V	
C136(C236)	1-108-843-12	0.033	50V	mylar
C137(C237)	1-108-657-12	0.01	100V	mylar
C138(C238)	1-121-396-11	4.7	50V	
C181(C281)	1-121-990-11	22	16V	
C182(C282)	1-105-677-12	0.22	50V	mylar
C183(C283)	1-105-677-12	0.22	50V	mylar
C301	1-121-395-11	4.7	25V	
C302	1-121-409-11	47	25V	
C303	1-108-657-12	0.01	100V	mylar
C304	1-121-396-11	4.7	50V	
C305	1-121-352-11	47	10V	
C306	1-121-396-11	4.7	50V	
C331	1-102-355-11	0.01 (2 pieces)	500V	ceramic
C332/C333	1-123-144-11	10000	70V	electrolytic (block type)
C334	1-102-355-11	0.01 (2 pieces)	500V	ceramic
C335	1-105-757-12	0.022	200V	mylar
C336	1-105-757-12	0.022	200V	mylar
C337	1-121-990-11	22	16V	
C338	1-121-990-11	22	16V	
C401	1-121-245-11	1000	16V	

Ref. No.	Part No.	Description
----------	----------	-------------

RESISTORS

All resistors are in Ω . $\frac{1}{4}\text{W}$, $\pm 5\%$ carbon resistors (except particular type) are omitted. Check schematic diagram for the resistance values. k = 1000, M = 1000 k.

R109(R209)	1-211-913-11	1k	$\pm 1\%$	carbon
R117(R217)	1-210-509-11	33k	$\pm 1\%$	carbon
R141(R241)	1-209-144-21	4.7	1W	carbon
R143~R145 (R243~R245)	1-217-158-11	0.47	5W	metal
R156(R256)	1-209-144-21	4.7	1W	carbon
R158~R160 (R258~R260)	1-217-158-11	0.47	5W	metal
R165(R265)	1-209-148-21	10	1W	carbon
R181(R281)	1-206-640-11	100	2W	metal-oxide
R182(R282)	1-206-648-11	220	2W	metal-oxide
R183(R283)	1-206-644-11	150	2W	metal-oxide
R316	1-210-509-11	33k	$\pm 1\%$	carbon
R331	1-206-099-11	3.3k	1W	metal-oxide
R341(R342)	1-206-128-11	820	2W	metal-oxide
RT101(RT201)	1-224-550-00	220	adjustable	
RT102(RT202)	1-224-490-00	4.7k	adjustable	
RT181(RT281)	1-224-250-00	2.2k	adjustable	
RT301	1-224-251-00	4.7k	adjustable	
RT331	1-224-488-00	470	adjustable	
RT401	1-224-489-00	2.2k	adjustable	
RV101(RV201)	1-224-481-00	100k (B)	variable (INPUT LEVEL)	
RV102(RV202)	1-224-484-00	100k (B)	variable (SPEAKER LEVEL)	

SWITCHES

S1,S2	1-516-081-00	Slide (NORMAL/TEST)
S3	1-516-583-00	Pushbutton, 2-key (FUNCTION)
S4	1-516-584-00	Pushbutton, 2-key (METER SENSITIVITY)
S5	1-516-586-00	Rotary (SPEAKER)

<u>Ref. No.</u>	<u>Part No.</u>	<u>Description</u>
S6	1-516-580-00	Slide (MODE)
S7~S9	1-516-582-00	Pushbutton, 4-key (POWER LIMITER)
S10	1-516-585-00	Pushbutton (POWER)

MISCELLANEOUS

CNJ301	1-509-403-00	Outlet, ac
CNP301	1-534-992-00	Cord, power
CP301	1-231-057-00	Encapsulated Component, 0.033 μ F + 120 Ω
F301,F302	1-532-227-00	Fuse, 6.3A
J101(J201) J102(J202)	1-536-352-00	Jack, phono; 4-P
L131(L231) L132(L232)	1-407-592-00	Microinductor, 1.8 μ H
L331	1-421-243-00	Coil, choke
PL301	1-518-158-00	Lamp, POWER
PT301	1-442-327-00	Transformer, power
TM301~ TM303	1-535-090-00	Terminal Strip (SPEAKER)
VS301	1-526-520-11	Selector, voltage
	1-508-649-00	Connector, 10-P (male)
	1-508-650-00	Connector, 6-P (male)
	1-508-652-00	Connector, 8-P (male)
	1-508-692-00	Connector, 6-P (male)

<u>Ref. No.</u>	<u>Part No.</u>	<u>Description</u>
	1-508-694-00	Connector, 8-P (male)
	1-509-667-00	Socket, transistor
	1-520-186-21	Meter, PEAK PROGRAM
	1-533-100-00	Holder, fuse
	1-536-354-00	Pin, terminal

CARTON AND ACCESSORIES

X-3701-029-0	Card Ass'y, warranty
X-4490-002-0	Cloth Ass'y, polishing
1-506-138-11	Plug, phono (red)
1-506-138-12	Plug, phono (white)
3-701-020-00	Bag, polyethylene; instruction manual
3-701-300-00	Bag, polyethylene; unit
3-701-730-00	Bag, polyethylene; IBM card
3-701-742-00	Card, IBM
3-780-427-21	Manual, instruction
3-793-765-21	Sheet, check
4-836-256-00	Carton
4-836-257-00	Cushion, side
4-836-258-00	Cushion, lower
4-836-259-00	Cushion