

# TA-V5

156

Canadian Model  
AEP Model  
UK Model  
E Model

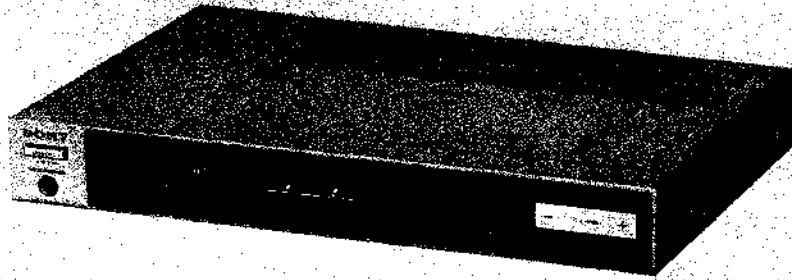

## INTEGRATED STEREO AMPLIFIER

### SPECIFICATIONS

#### Amplifier section

Continuous RMS power output  
(both channels driven simultaneously)

At 1 kHz  
70 + 70 watts (5% THD, 6 ohms)  
55+55 Watts (0.05% THD, 6 ohms)

At 20 Hz - 20 kHz  
50 + 50 watts (0.05% THD, 6 ohms)

According to DIN 45500  
50 + 50 watts (0.05% THD, 6 ohms)

Power bandwidth (IHF) 10 Hz - 50 kHz

Dynamic headroom 1.2 dB (\*78 IHF)

Harmonic distortion Less than 0.05% at rated output

Intermodulation (IM) distortion  
(60 Hz - 7 kHz = 4 : 1) Less than 0.05% at rated output

Frequency response PHONO : RIAA equalization curve  $\pm 0.5$  dB  
TUNER, CD, AUX, TAPE, AUX, TAPE 2 :  
10 Hz - 50 kHz  $\pm 0.2$  dB

Residual noise Less than 100  $\mu$ V (6 ohms, network A)

Damping factor 25 (6 ohms, 1 kHz)

Inputs

	Sensitivity	Impedance	Maximum input capability (1 kHz)	S/N (weighting network, input level)
PHONO	2.5 mV	50 k $\Omega$	100 mV	73 dB 75 dB* (A, 2.5 mV)
TUNER, CD, AUX, TAPE, AUX, TAPE 2	150 mV	50 k $\Omega$	—	98 dB 80 dB* (A, 150 mV)

\* :78 IHF

—Continued on page 2—

#### WARNING!!

THIS SET USES THE SWITCHING-TYPE POWER-SUPPLY CIRCUIT, WHICH IS DIRECTLY CONNECTED TO THE AC POWER LINE. AN ISOLATION TRANSFORMER SHOULD BE USED DURING ANY SERVICE TO AVOID POSSIBLE SHOCK HAZARD.

#### ATTENTION!!

CET APPAREIL UTILISE UN CIRCUIT D'ALIMENTATION D'IMPULSION (DE TYPE COMMUTATION) QUI EST DIRECTEMENT BRANCHÉ SUR LE RECTENUE ÉLECTRIQUE. UN TRANSFORMATEUR D'ISOLEMENT DOIT ÊTRE UTILISÉ LORS DU DÉPANNAGE POUR ÉVITER TOUT RISQUE D'ÉLECTROCUTION.

#### ATTENTION AU COMPOSANT AYANT RAPPORT À LA SÉCURITÉ!

LES COMPOSANTS IDENTIFIÉS PAR UNE TRACÉ ET UNE MARQUE  SUR LES DIAGRAMMES SCHEMATIQUES ET LA LISTE DES PIÈCES SONT CRITIQUES POUR LA SÉCURITÉ DE FONCTIONNEMENT. NE REMPLACER CES COMPOSANTS QUE PAR DES PIÈCES SONY DONT LES NUMÉROS SONT DONNÉS DANS CE MANUEL OU DANS LES SUPPLÉMENTS PUBLIÉS PAR SONY.

#### SAFETY-RELATED COMPONENT WARNING!!



MICROFILM

COMPONENTS IDENTIFIED BY SHADING AND MARK  ON THE SCHEMATIC DIAGRAMS AND IN THE PARTS LIST ARE CRITICAL TO SAFE OPERATION. REPLACE THESE COMPONENTS WITH SONY PARTS WHOSE PART NUMBERS APPEAR AS SHOWN IN THIS MANUAL OR IN SUPPLEMENTS PUBLISHED BY SONY.

# SONY

## SERVICE MANUAL

156

Outputs	<b>REC OUT</b> Voltage 150 mV Impedance 4.7 k ohms <b>SPEAKER A, B</b> Accepts speakers of 6 - 16 ohms. <b>HEADPHONES</b> Accepts low impedance headphones.
Tone controls	<b>BASS</b> $\pm 10$ dB at 100 Hz <b>TREBLE</b> $\pm 10$ dB at 10 kHz
Loudness (att. 30 dB)	+ 6 dB at 100 Hz + 3 dB at 10 kHz
Subsonic filter	6 dB/octave attenuation below 15 Hz
<b>General System</b>	Preamplifier section: low-noise NF type equalizer amp.; NF type tone control Power amplifier section: pure-complementary SEPP OTL OCL amplifier Power supply section: pulse power supply circuitry
Power requirements	Canadian model : 120 V ac, 60Hz AEP model : 220 V ac, 50/60 Hz UK model : 240 V ac, 50 Hz E model : 120, 220 or 240 V ac adjustable, 50/60 Hz
Power consumption	Canadian model : 160 watts AEP model : 60 watts UK model : 65 watts E model : 65 watts
AC outlets	AEP, UK model : 1 switched, 100 watts max. Canadian, E model : 1 switched, 100 watts max. 1 unswitched, 100 watts max.

### Dimensions

AEP model :  
 Approx. 355 x 55 x 258 mm (w/h/d)  
 (14 x 2<sup>1</sup>/<sub>4</sub> x 10<sup>1</sup>/<sub>4</sub> inches)

UK, Canadian, E model :  
 Approx. 355 x 55 x 255 mm (w/h/d)  
 (14 x 2<sup>1</sup>/<sub>4</sub> x 10 inches)

including projecting parts and controls  
 Approx. 2.9 kg (6 lbs 6 oz) net  
 Approx. 3.3 kg (7 lbs 5 oz) in shipping carton

### Weight

While the information given is true at the time of printing, small production changes in the course of our company's policy of improvement through research and design might not necessarily be indicated in the specifications.

We would ask you to check with your appointed Sony dealer if clarification on any point is required.

### MODEL IDENTIFICATION

—Specification Label—

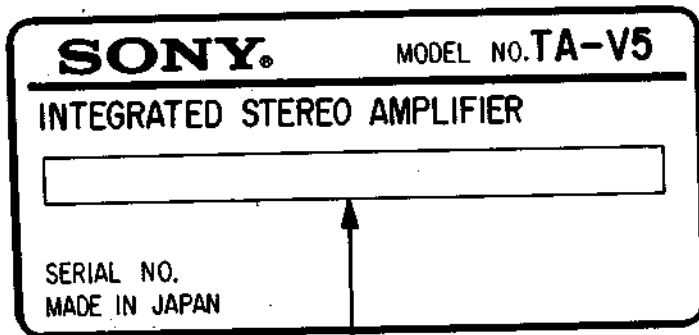

Canadian model: AC: 120V 60Hz 160W  
 AEP model: AC: 220V~ 50/60Hz 60W  
 E1/E2 model: AC: 120/220/240V~ 50/60Hz 65W  
 UK model: AC: 240V~ 50/60Hz 65W

### SAFETY CHECK-OUT

After correcting the original service problem, perform the following safety checks before releasing the set to the customer:

1. Check the area of your repair for unsoldered or poorly-soldered connections. Check the entire board surface for solder splashes and bridges.
2. Check the interboard wiring to ensure that no wires are "pinched" or contact high-wattage resistors.
3. Look for unauthorized replacement parts, particularly transistors, that were installed during a previous repair. Point them out to the customer and recommend their replacement.
4. Look for parts which, though functioning, show obvious signs of deterioration. Point them out to the customer and recommend their replacement.
5. Check the B+ voltage to see it is at the values specified.

# SECTION 1 OUTLINE

## 1-1. FEATURES

The Sony TA-V5 integrated stereo amplifier provides dynamic high-fidelity sound despite a remarkably compact cabinet.

- Slim, smart case.
- Hi-ft power transistors with high-speed response and high power handling capacity for low distortion.
- A lightweight power supply section using pulse techniques.
- Motorized push-type VOLUME control button and LED volume indicators.
- CD inputs for connecting a CD (compact disc) player.
- A second tape recorder input on the front panel for tape playback and duplication.
- Bass boost switch to compensate for the reduced bass response where a small speaker system is used.
- A subsonic filter switch to reduce subsonic noise components caused by warped record.
- Flat, soft-touch function keys.
- Ability to drive two pairs of speaker systems either individually or simultaneously.

## 1-3. BLOCK DIAGRAM

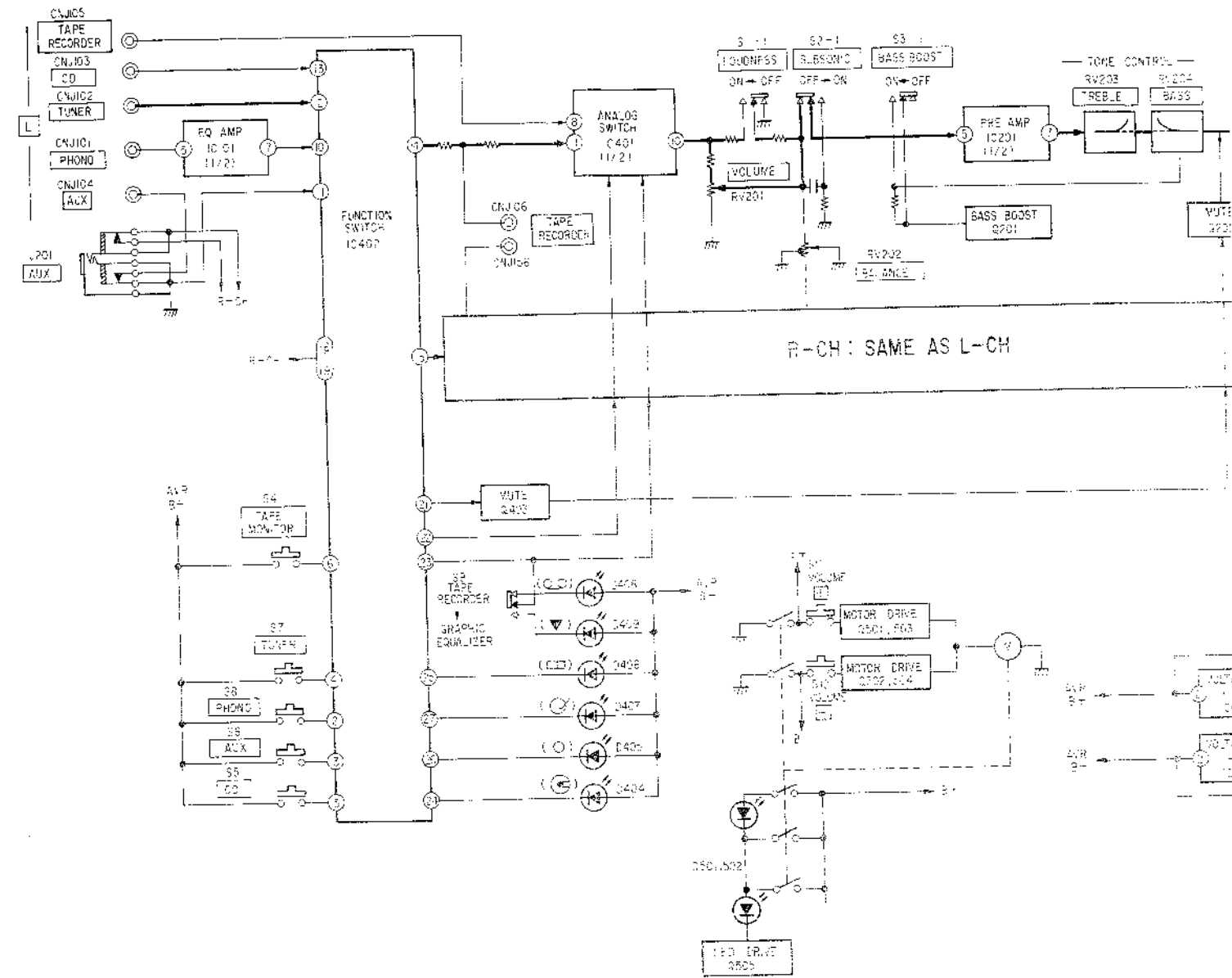

## 1-2. LOCATION OF CONTROLS

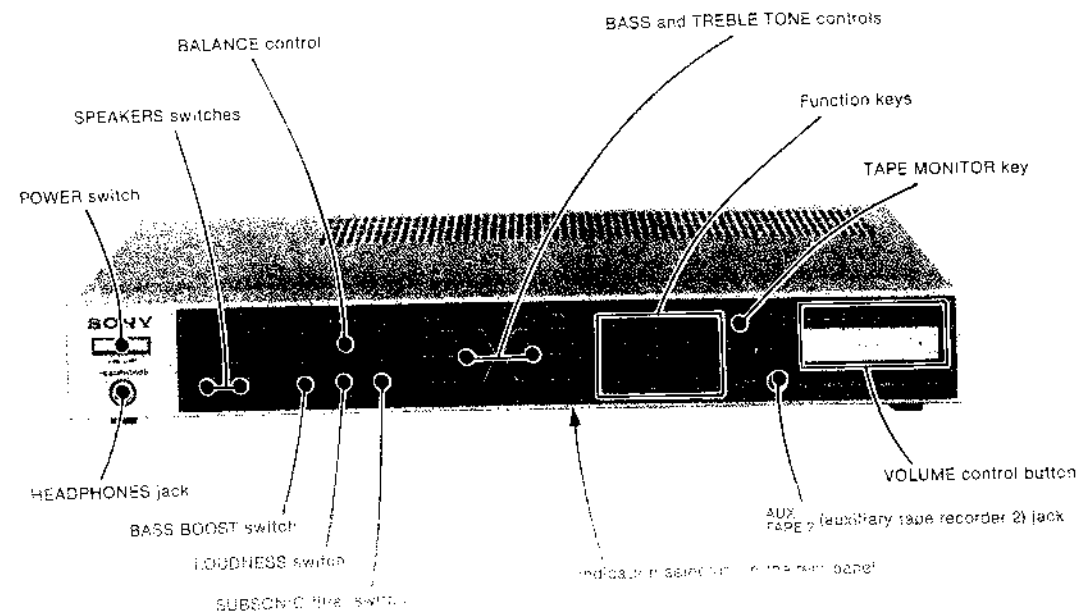

1-3. BLOCK DIAGRAM

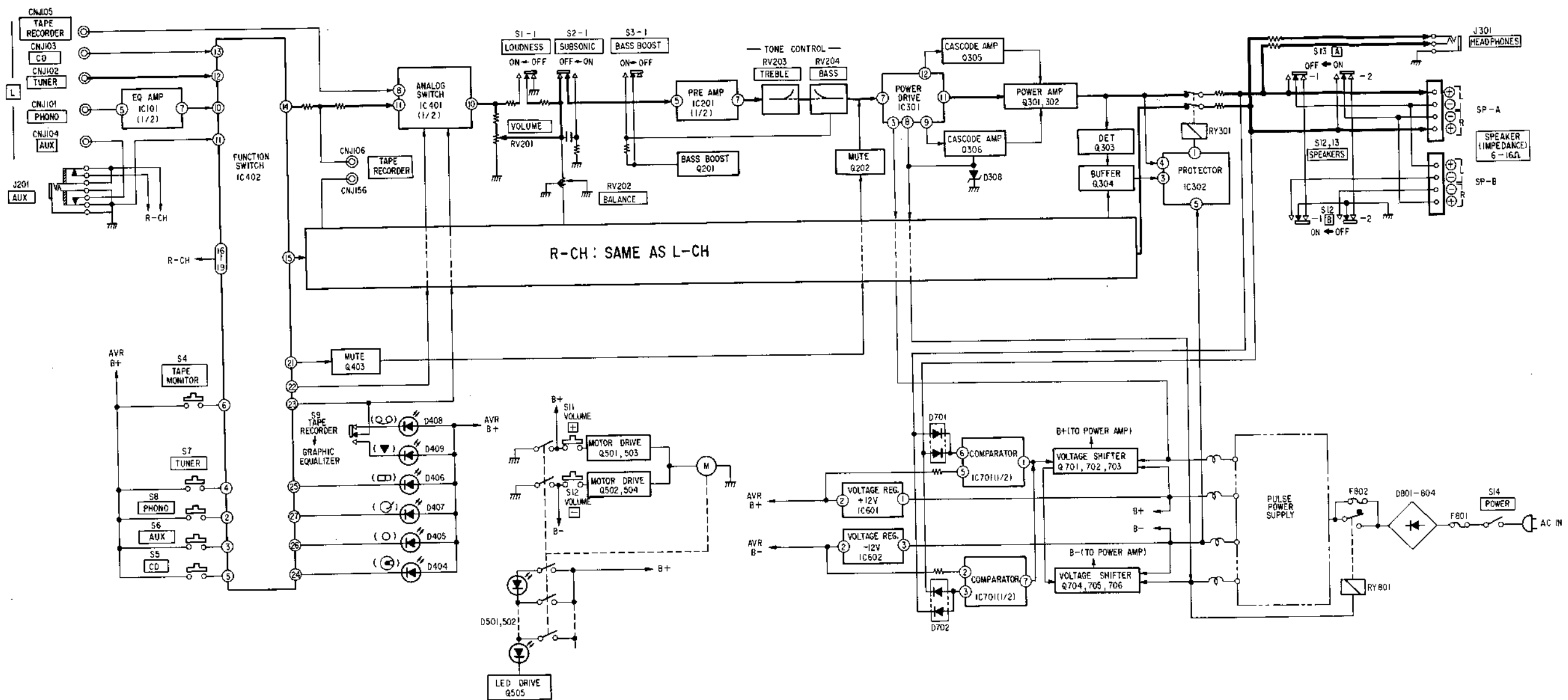

SECTION 2  
DISASSEMBLY

2-1. REMOVAL

- Follow the disassembly procedure in the numerical order given.

CASE

Remove four (4) M3 case screws from both sides.

SEE NOTE 1.\*

POWER-AMPLIFIER BOARD

2 Remove two (2) +BVTT 3x6 screws.

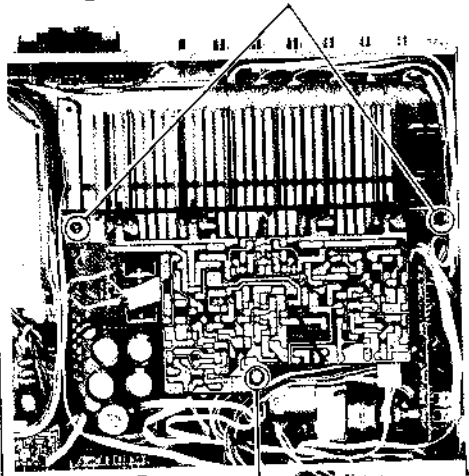

1 Release the power-amplifier circuit board from the plastic support.

3 Lift up the power-amplifier circuit board together with the heat sink taking care not to bend the power-transistor leads.

FRONT PANEL (1)

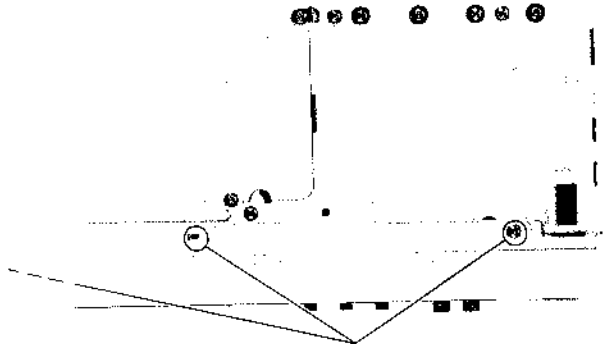

1 Remove three (3) +BVTT 3x6 screws from the bottom of the front panel.

\*NOTE1:

Route X: To remove balance control, tone, switch and tape 2 boards without removing subpanel.

Route Y: To remove balance control, tone, switch and tape 2 boards by removing subpanel.

CONTROL BOARD

2 Slightly displace the control board toward rear.

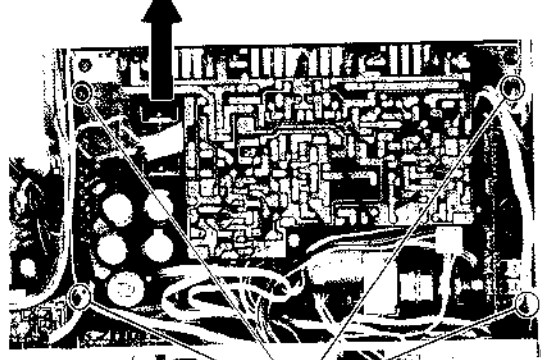

1 Remove four (4) +BVTT 3x6 screws from four (4) corners of the control board.

TONE BOARD

1 Bend the two (2) claws of the sub panel straight back and remove the blind panel (A).

2 Remove upper-side control-fastening screw +BVTT 2x4 and loosen lower-side control-fastening screw +BVTT 2x4.

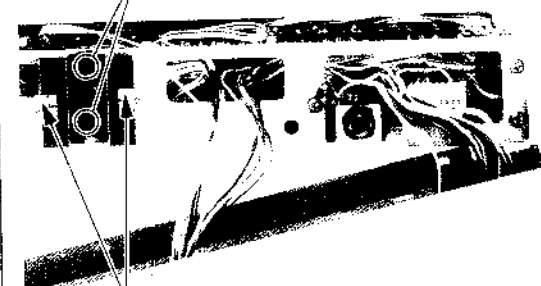

3 Remove two (2) knobs.

TAPE 2 BOARD

1 Remove a lug-fastening screw +BVTT 3x6.

2 Remove jack nut.

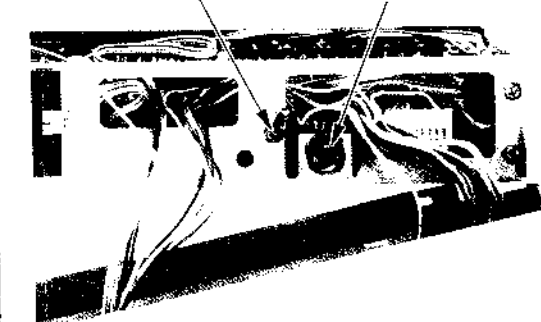

PPS UNIT (3)

3 Remove three (3) screws from the rear of the PPS unit case.

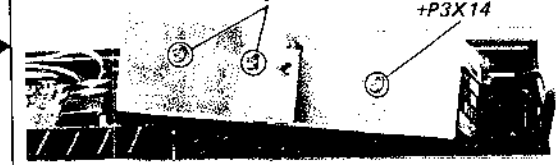

PPS UNIT (2)

2 Remove sixteen (16) +BVTT 3x6 screws from the four (4) edges of the PPS unit cases.

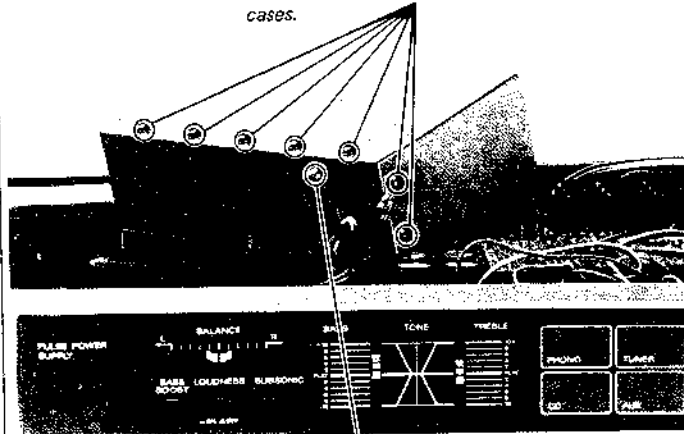

Note: Do not remove this screw.

SUBPANEL (1)

Bend the two (2) sub panel claws straight back and remove the blind panel (B).  
Remove two (2) control-fastening screws +BVTT 2.6x4.

Bend the two (2) sub-panel claws straight back and remove the blind panel (A).  
Remove the upper-side control-fastening screw +BVTT 2x4 and loosen the lower-side control-fastening screw +BVTT 2x4.

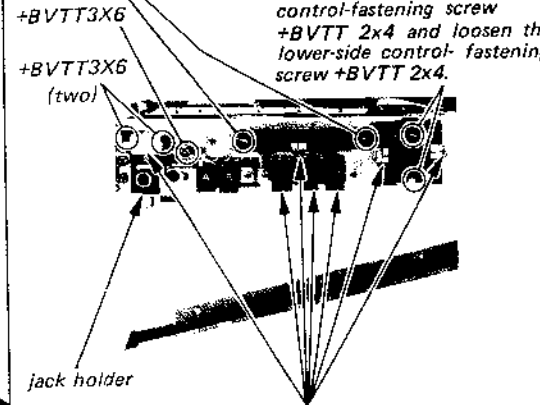

jack holder

Remove knobs and buttons.

+BVTT3X6 jack nut

FRONT PANEL (2)

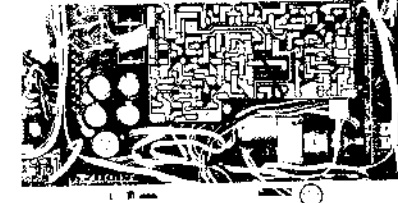

2 Release two (2) front-panel claws from the sub panel and pull the front panel forward.

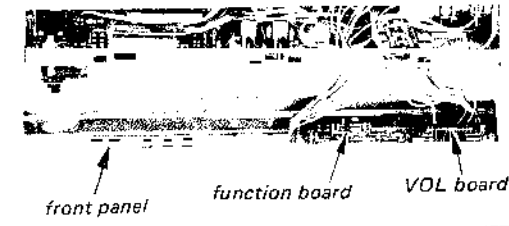

front panel

function board

VOL board

TONE and TAPE (2) BOARDS

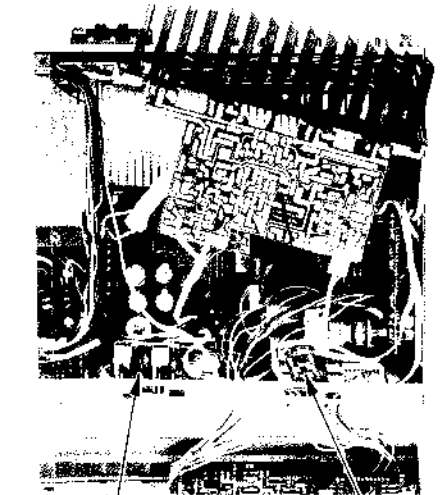

tone board

TAPE 2 board

PPS UNI

5 Rele. plast. PPS c

SUBPAN

+BVTT3x (one)

BALAN

1 E

2

3

4

5

6

7

**NIT (2)**

2 Remove sixteen (16) +BVTT 3x6 screws from the four (4) edges of the PPS unit cases.

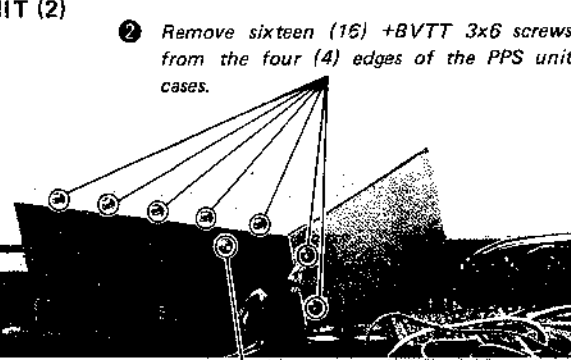
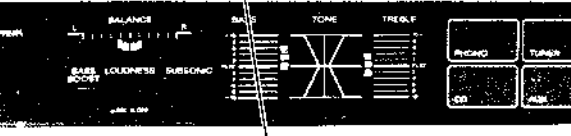
Note: Do not remove this screw.

**PPS UNIT (3)**

3 Remove three (3) screws from the rear of the PPS unit case.

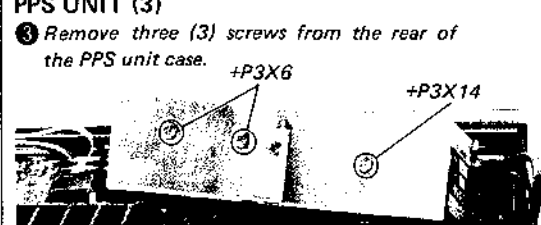

+P3X6  
+P3X14

**PPS UNIT (4)**

4 Remove PPS unit case.

5 Release two (2) claws of the plastic case to remove the PPS circuit board.

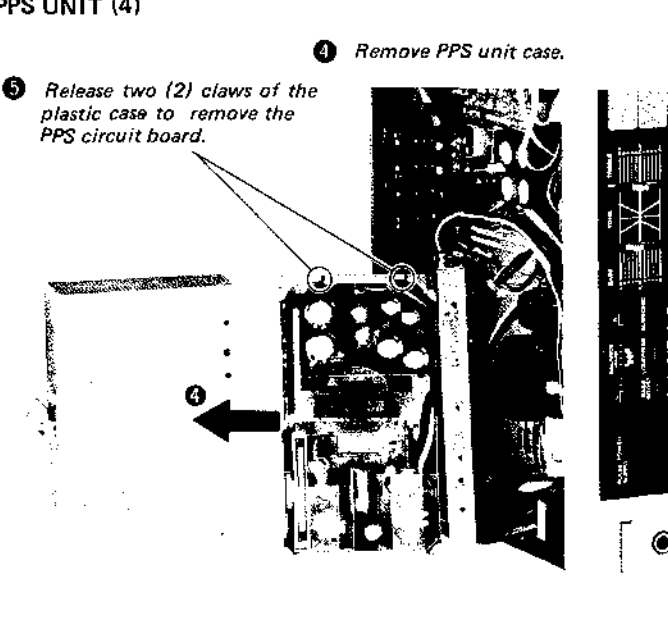

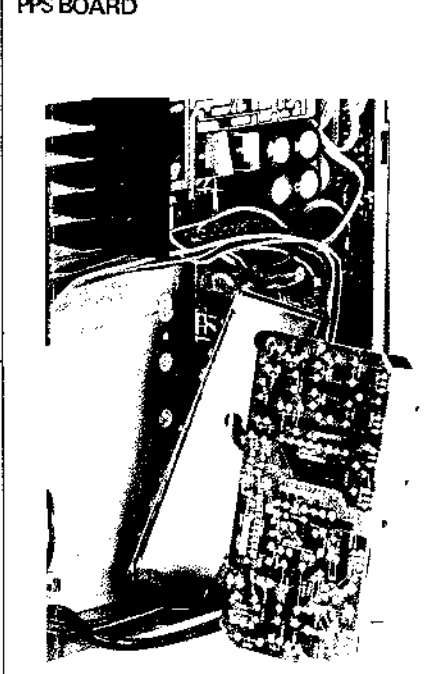

**PPS BOARD**



**T PANEL (2)**

2 Release two (2) front-panel claws from the sub panel and pull the front panel forward.

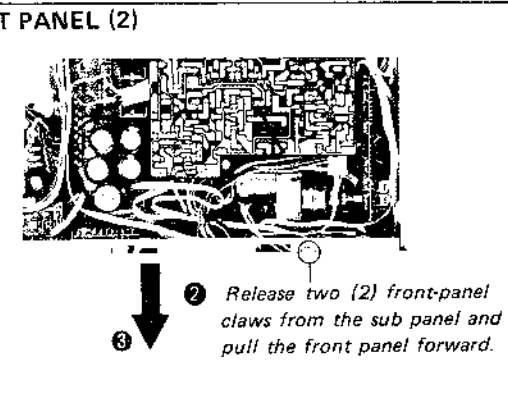
3





front panel    function board    VOL board

**SUBPANEL (1)**

Bend the two (2) sub panel claws straight back and remove the blind panel (B).  
Remove two (2) control-fastening screws +BVTT 2.6x4.

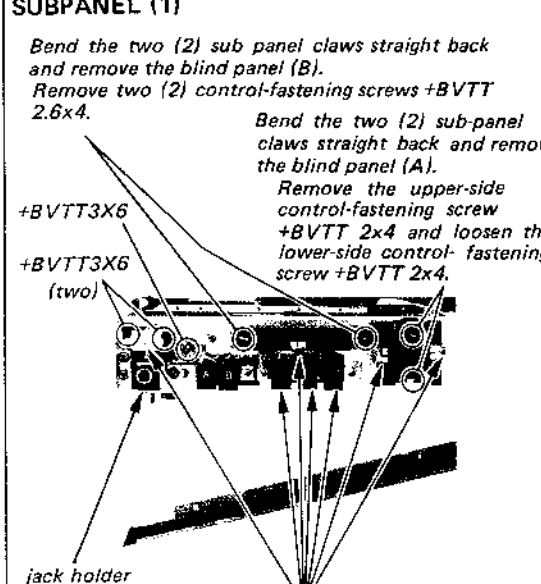
Bend the two (2) sub-panel claws straight back and remove the blind panel (A).  
Remove the upper-side control-fastening screw +BVTT 2x4 and loosen the lower-side control-fastening screw +BVTT 2x4.



+BVTT3X6  
+BVTT3X6 (two)

jack holder

Remove knobs and buttons.

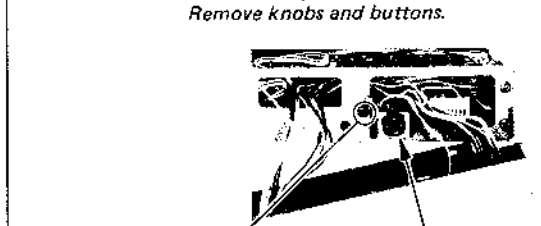

+BVTT3X6    jack nut

**SUBPANEL (2)**

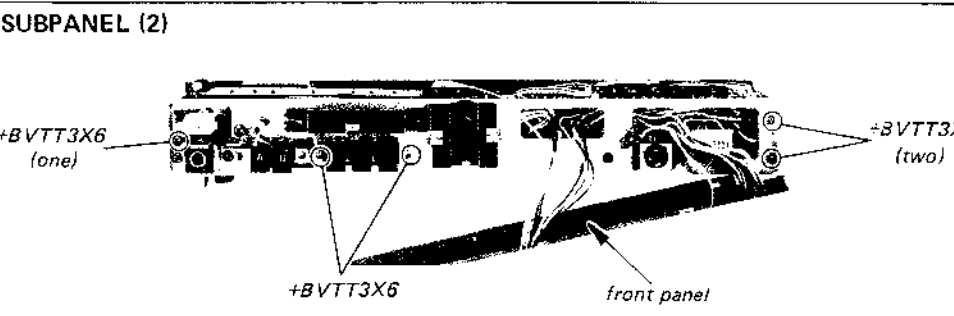

+BVTT3X6 (one)    +BVTT3X6 (two)

front panel

**2 BOARD**

Remove a lug-fastening screw +BVTT 3x6.

1 Remove jack nut.

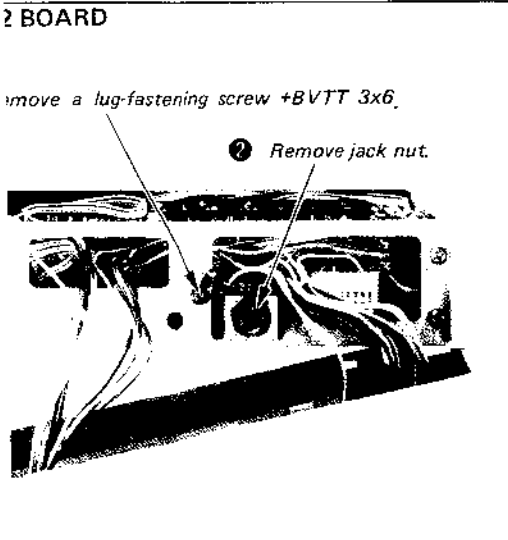

**TONE and TAPE (2) BOARDS**

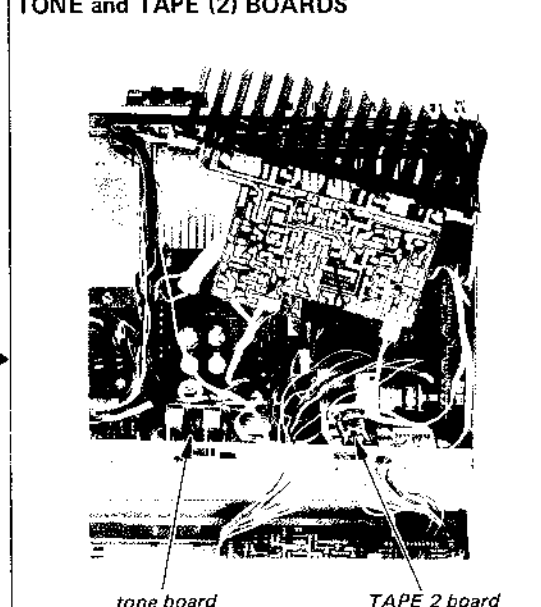

tone board    TAPE 2 board

**BALANCE CONTROL BOARD (1)**

1 Bend the two (2) sub-panel control-fastening claws and remove the blind panel (B).  
Remove two (2) control-fastening screws +BVTT 2.6x4.

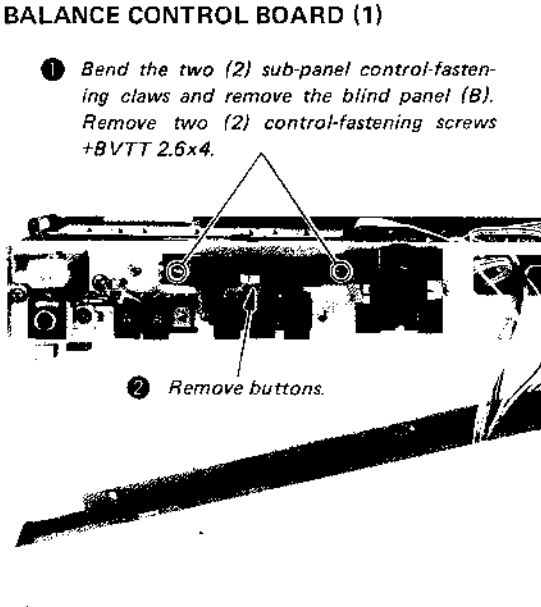

2 Remove buttons.

**BALANCE CONTROL BOARD (2)**

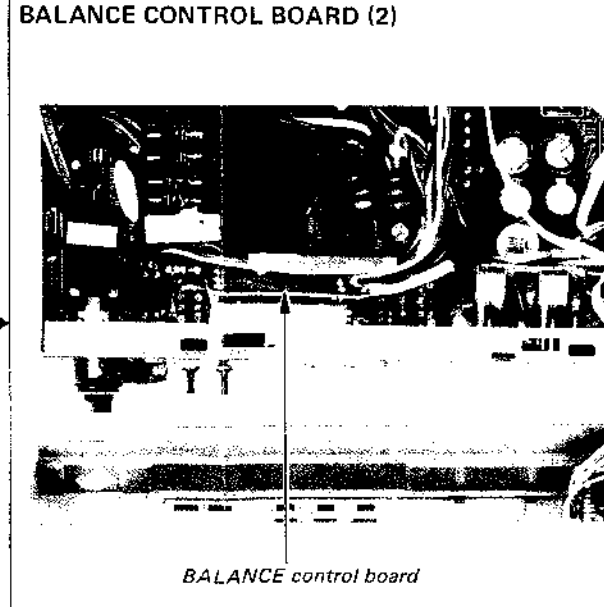

BALANCE control board

**PPS BOARD**

Checking and repairing to the PPS circuit can be made by connecting the grounding lug from the PPS circuit to the chassis ground in this condition.

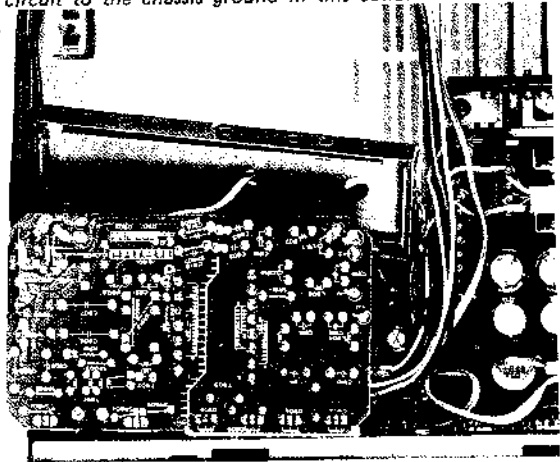

Note:  
Checkings to the unit can be made under this and no-signal condition without heat sinking for a short period of time.

**SWITCH BOARD (3)**

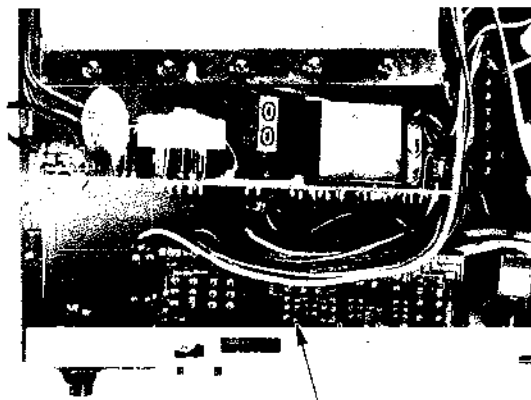

When further the speaker terminal board and slide switch are removed from the jack panel or the jack panel is removed, all circuit boards and PPS unit removed can be reconnected as shown below.

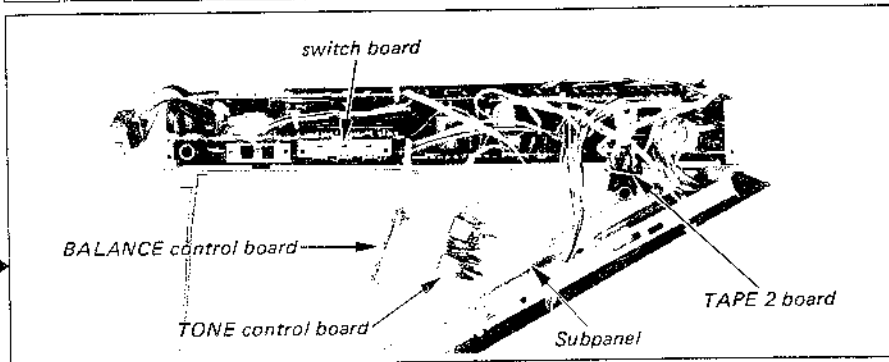
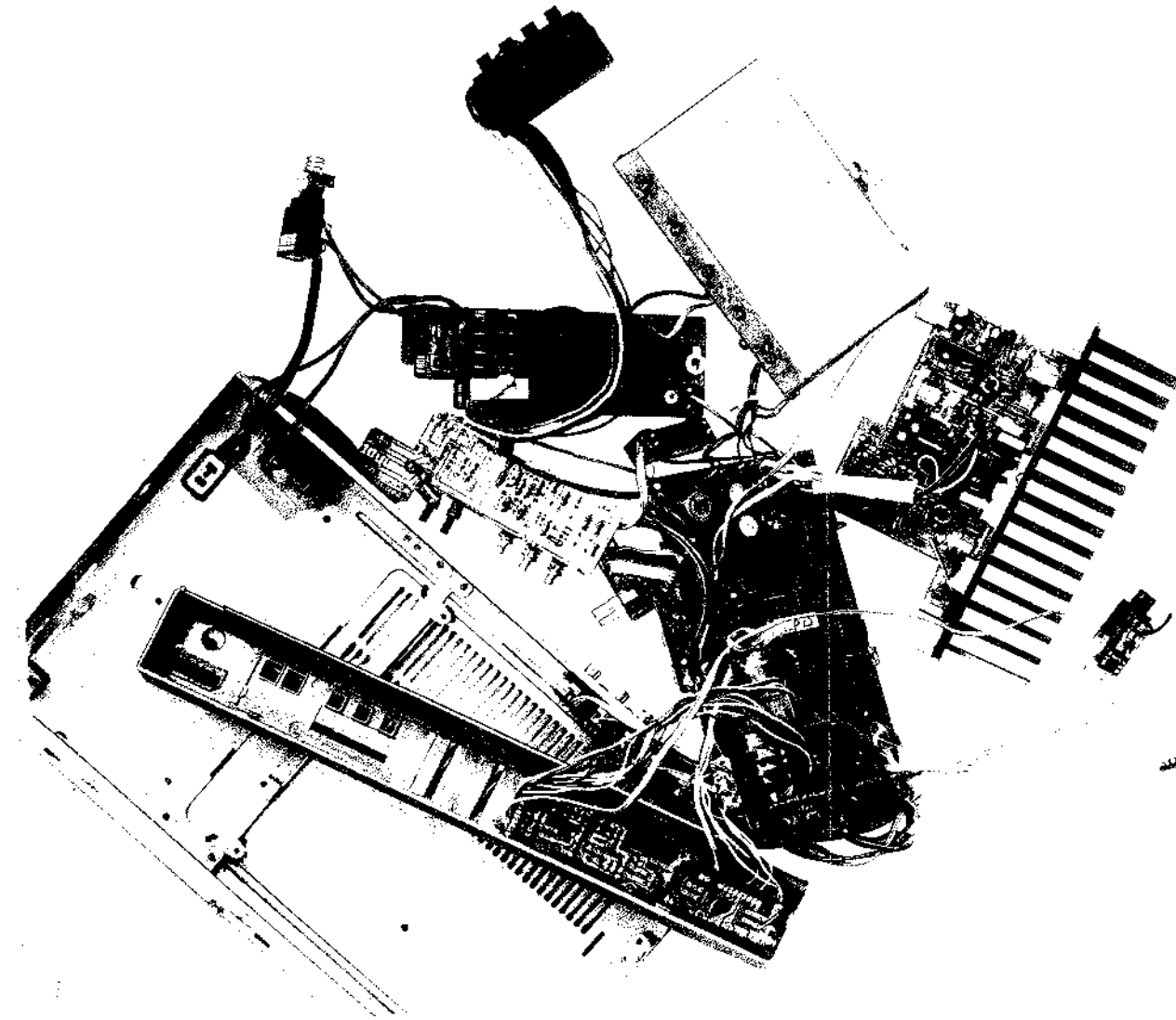

"FUNCTION SWITCH BOARD",  
VOL SWITCH BOARD".

**SWITCH BOARD (1)**

- 1 Release power-supply board from the plastic support.
- 2 +BVTT3X6 grounding lug

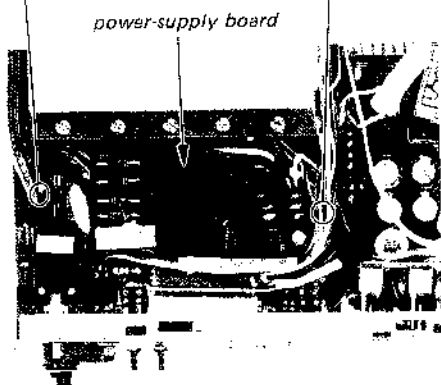

- 3 Turn the power-supply board to make the component side face the PPS unit and to provide clearance.

**SWITCH BOARD (2)**

- 4 Remove two (2) +BVTT 3x6 and remove POWER switch.
- 5 Remove buttons.
- 6 Remove jack holder.
- 7 Remove three (3) screws +BVTT 3x6.

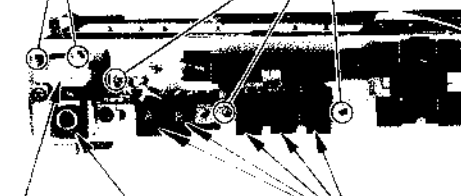

- 4 Remove POWER button
- 5 Remove buttons.
- 6 Remove jack holder.

SECTION 3  
ADJUSTMENTS

3-1. ELECTRICAL ADJUSTMENT

DC BIAS ADJUSTMENT

In no signal condition, adjust RV301(L-CH), and RV351 (R-CH) for 11mVDC VOM reading across R314(L-CH) and R364(R-CH).

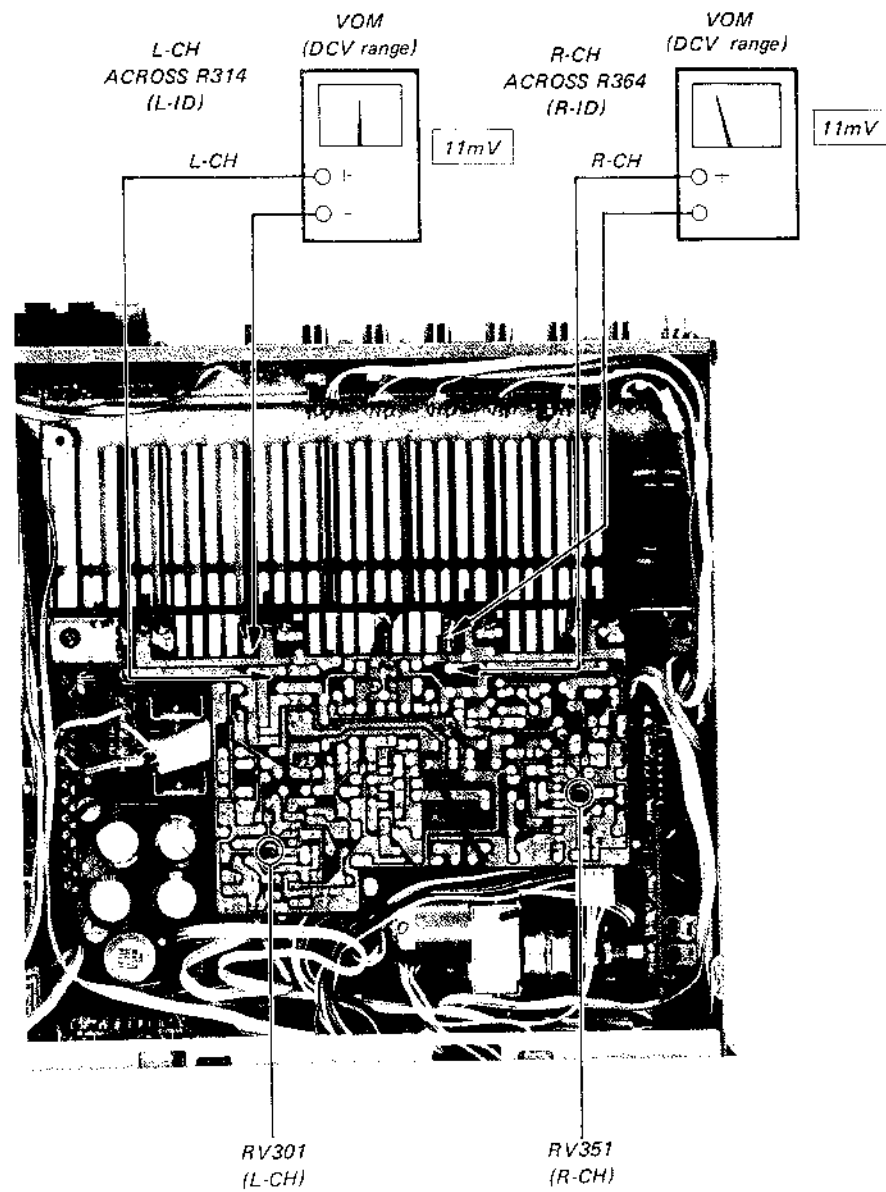

Note: Mechanical Adjustment is not applicable for this unit.

When Q903 and Q904 are replaced, a matched pair of them should be used. See page 38 for part numbers.

SECTION 4  
DIAGRAMS

4-1. SEMICONDUCTOR LEAD LAYOUTS AND NOTES

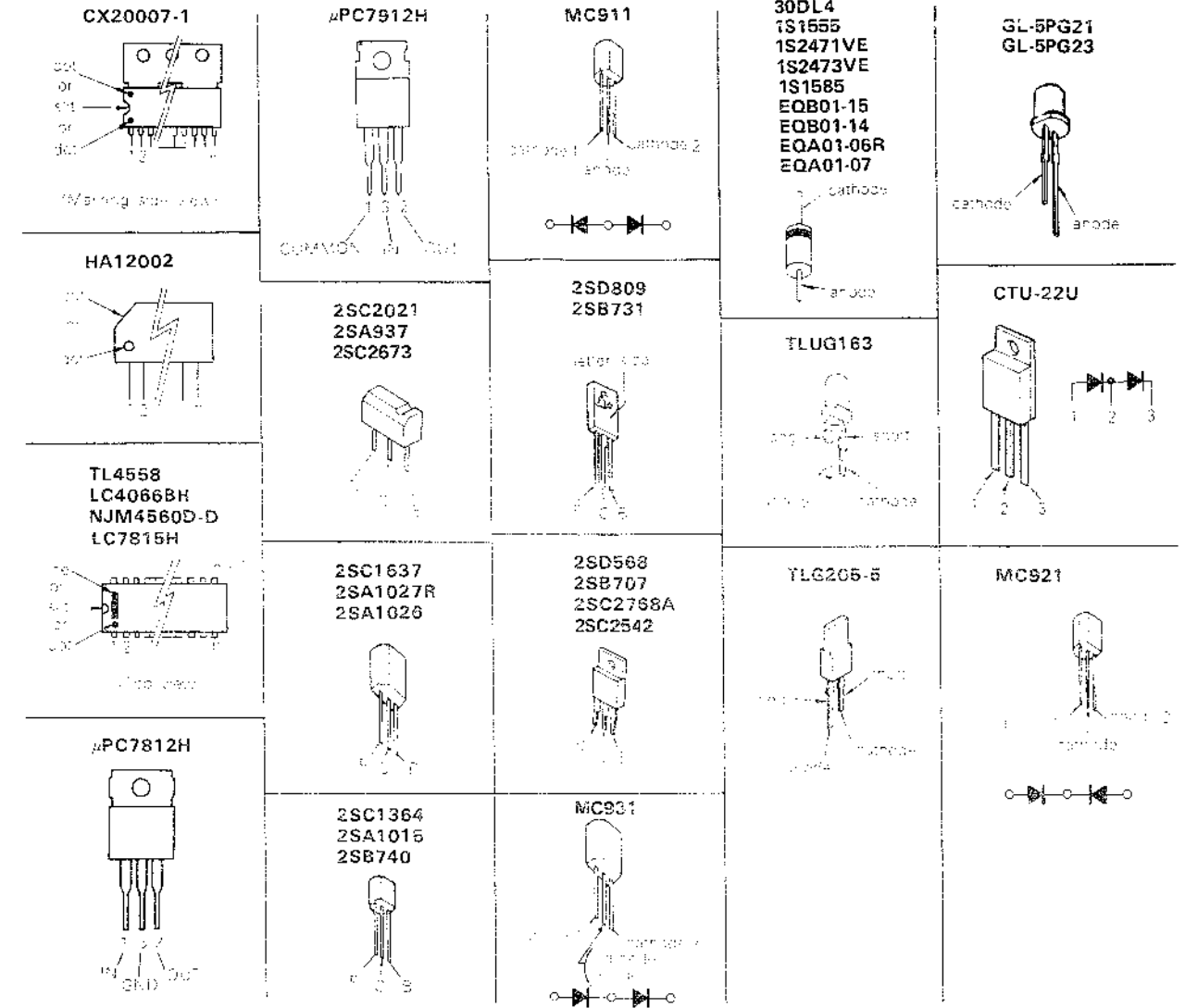

Note: FOR SCHEMATIC DIAGRAM

Note: The components identified by shading and mark  $\Delta$  are critical for safety. Replace only with part number specified.

- Components for right channel have same values as for left channel.
- All capacitors are in  $\mu\text{F}$  unless otherwise noted.  $\text{pF} : \mu\text{F}$  50WV or less are not indicated except for electrolytics and tantalums.
- All resistors are in ohms,  $\frac{1}{4}\text{W}$  unless otherwise noted.  $\text{k}\Omega : 1000\Omega$ ,  $\text{M}\Omega : 1000\text{k}\Omega$
- $\square$  : non-flammable resistor.
- $\square$  : fusible resistor.
- $\square$  : panel designation.

Note: Les composants identifiés par une trame et une marque  $\Delta$  sont critiques pour la sécurité. Ne les remplacer que par une pièce portant le numéro spécifié.

Ref. No.	Switch	Position
S1	LOUDNESS	OFF
S2	SUBSONIC	OFF
S3	BASS BOOST	OFF
S4	TAPE MONITOR	OFF
S5	CD	OFF
S6	TV SURT.	OFF
S7	TUNER	OFF
S8	RECORD	OFF
S9	APPROX. 100%	TAPEREORDER
S10	VOLUME (L)	OFF
S11	VOLUME (R)	OFF
S14	POWER	OFF







4-3. SCHEMATIC DIAGRAM See page 12 for note.

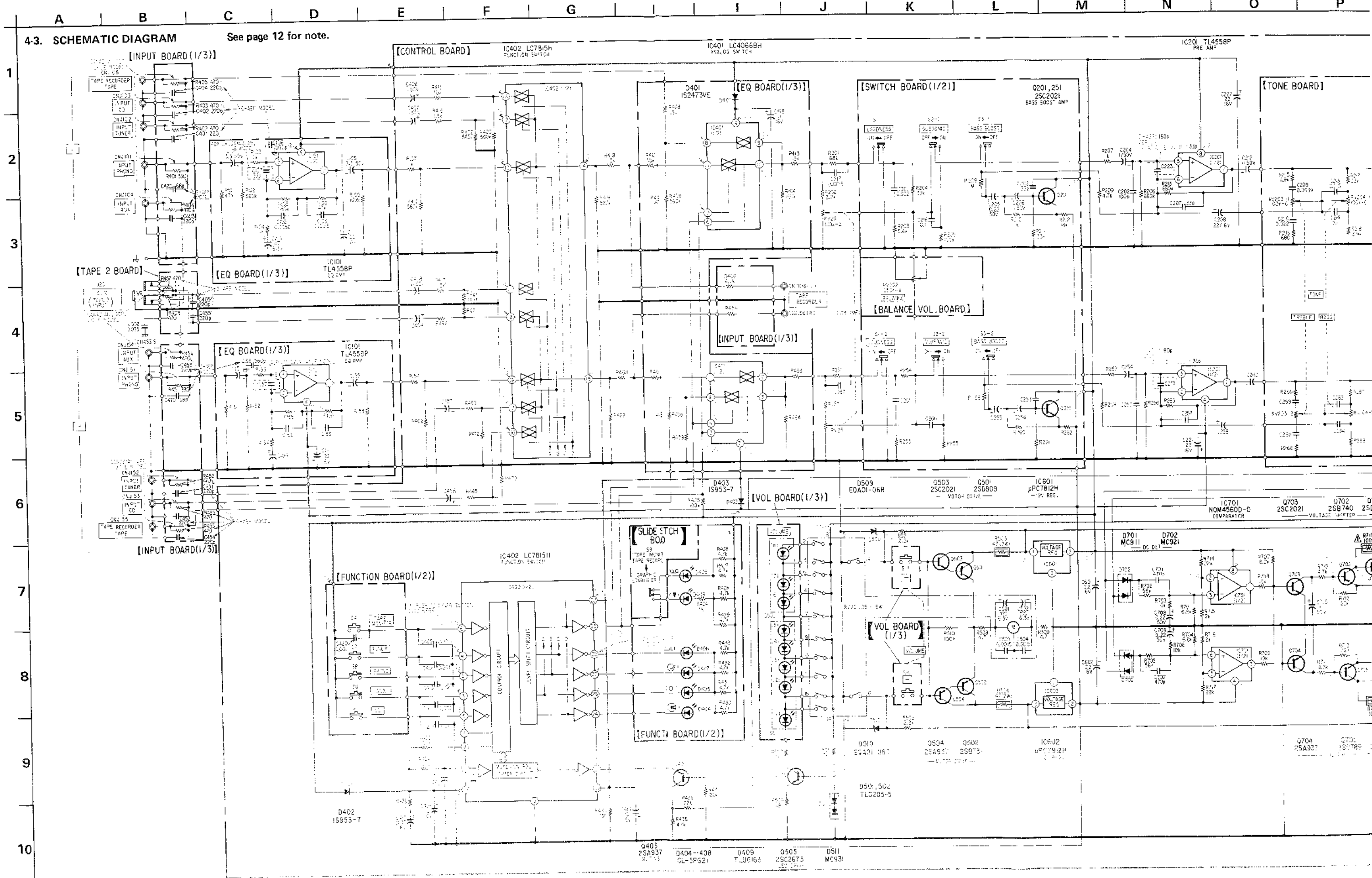

# TA-V5 TA-V5

O    P    Q    R    S    T    U    V    W    X    Y    Z    A1    B1    C1    D1

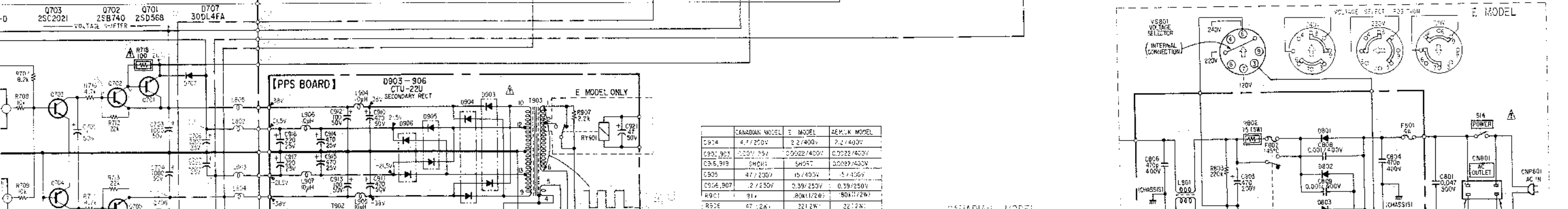
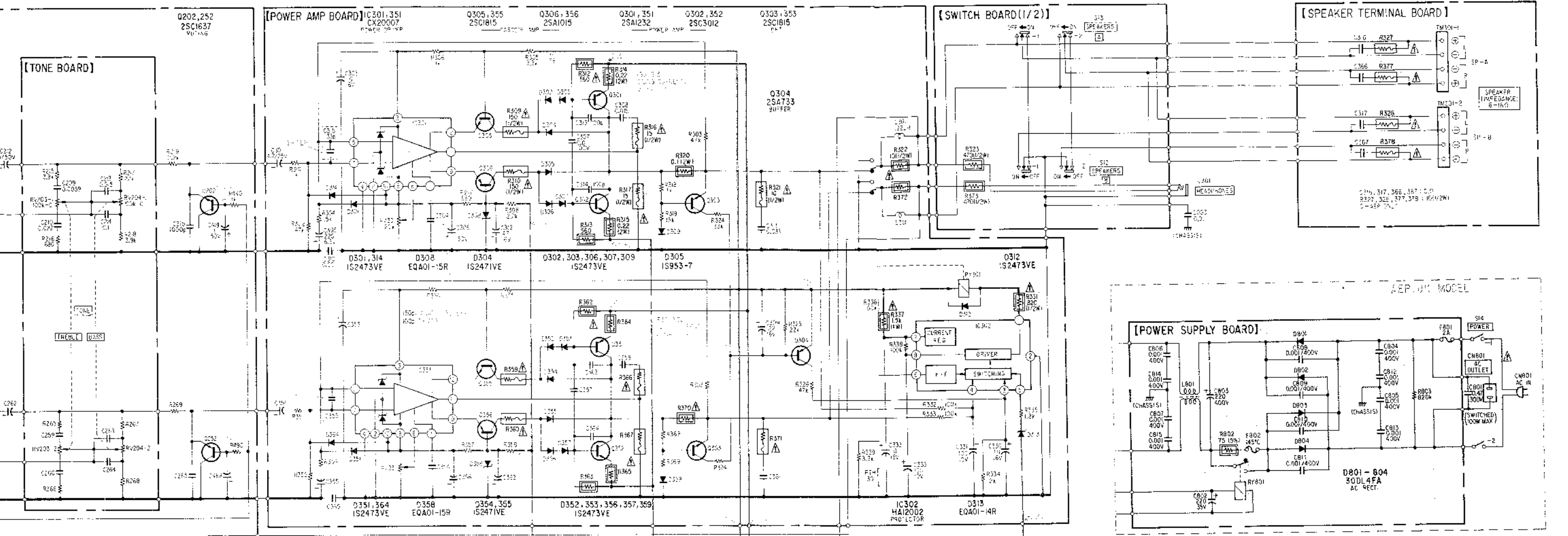

	CANADIAN MODEL	E MODEL	AEM/K MODEL
C804	4.7/200V	2.2/400V	2.2/400V
C802, C803	0.001/25V	0.0022/400V	0.0022/400V
C805, R101	SHORT	SHORT	300Ω/400V
C809	4.7/200V	15/400V	5/400V
C806, R807	2/250V	0.39/250V	0.39/250V
R801	31V	80K/1/2W	80K/1/2W
R802	47/2W	22/2W	22/2W

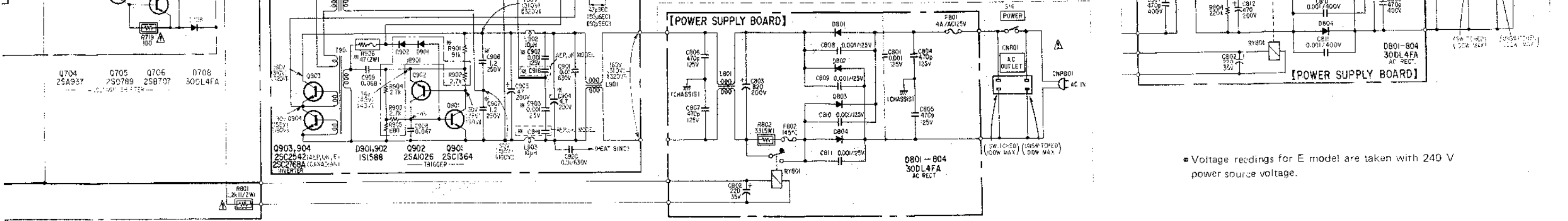

• Voltage readings for E model are taken with 240 V power source voltage.



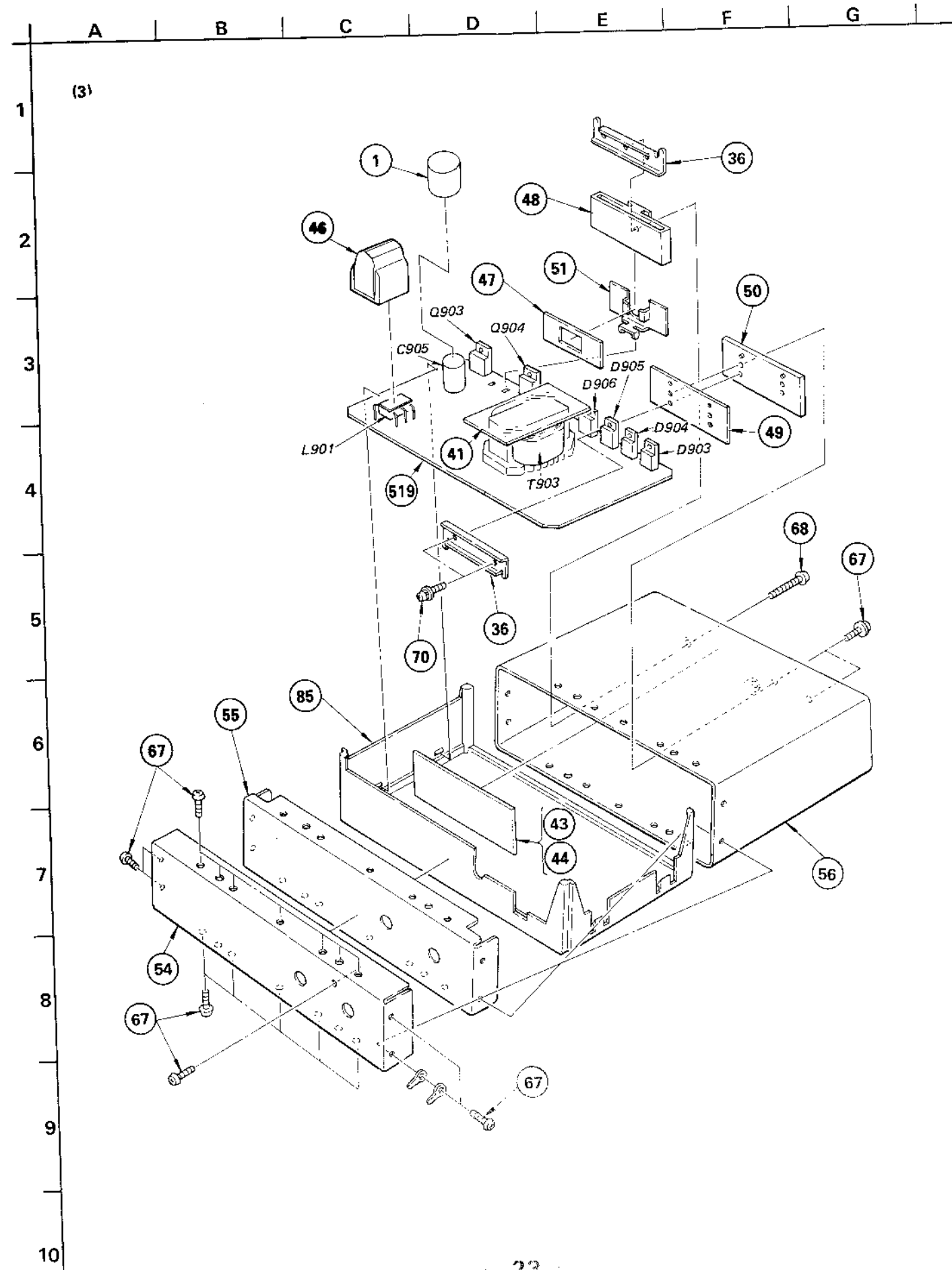

GENERAL SECTION

No.	Part No.	Description
1	2-259-757-00	CAP, SP
2	3-307-591-00	(G-AEP)...LABEL, FTZ
3	3-701-690-00	(UK)...LABEL, MADE IN JAPAN
4	3-701-993-00	SPACER, TERMINAL
5	3-703-043-00	(Canadian, UK)...LABEL, MAIN CAUTION
5	3-703-044-00	(Canadian)...LABEL, CAUTION
7	3-703-244-00	BUSHING, CORD
8	3-703-353-02	SUPPORT, PC BOARD
9	3-703-353-09	SUPPORT, PC BOARD
10	.....	.....
11	3-703-713-01	STICKER, SONY SYMBOL (10)
12	3-706-165-00	SCREW
13	3-831-441-XX	CUSHION, 23X4X0.5
14	4-838-926-00	PLATE (A), LUG TERMINAL
15	4-861-045-00	LABEL, CAUTION
16	4-864-307-00	RING
17	4-866-647-00	HEAT SINK
18	4-869-217-00	CLIP, CORD
19	4-870-539-00	PLATE, GROUND
20	.....	.....
21	4-875-466-00	JOINT (F2), KNOB
22	4-875-726-00	SHEET, INSULATING
23	4-886-002-00	(AEP,G-AEP,UK)...INSULATOR (D)
24	4-886-003-00	(AEP,G-AEP,UK)...INSULATOR (E)
25	4-886-803-00	(Canadian)...LABEL, MODEL NUMBER
25	4-886-804-00	(AEP,G-AEP)...LABEL, MODEL NUMBER
25	4-886-805-00	(UK)...LABEL, MODEL NUMBER
25	4-886-806-00	(E)...LABEL, MODEL NUMBER (E1)
26	4-886-809-00	(AEP,G-AEP)...BRACKET, INSULATOR (A)
27	4-886-810-02	PUSH BLOCK (Z)
28	4-886-811-00	PLATE (A), BLIND, SLIDE CONTROL
29	4-886-812-00	PLATE (B), BLIND, SLIDE CONTROL
30	4-886-813-00	KNOB, TONE CONTROL
31	4-886-814-01	KNOB (A), SPEAKER
32	4-886-814-11	KNOB (B), SPEAKER
33	4-886-815-00	(AEP,G-AEP)...INSULATOR (A)
34	4-886-816-01	KNOB, SLIDE CONTROL
35	4-886-819-00	BRACKET (A), HEADPHONES JACK
36	4-886-820-00	RETAINER
37	4-886-821-11	SCREW, M3 CASE
38	4-886-822-01	INSULATOR (B)
39	4-886-823-00	(AEP,G-AEP,UK)...INSULATOR (C)
40	4-886-823-11	(E)...INSULATOR (C)
41	4-886-824-00	INSULATOR, TRANSFORMER
42	4-886-825-00	BRACKET, TRANSFORMER
43	4-886-826-01	SHEET, INSULATING

GENERAL SECTION

No.	Part No.	Description
44	4-886-826-11	(Canadian)...SHEET, (INSULATING
44	4-886-826-21	(AEP,G-AEP,UK)...SHEET, INSULATING
45	4-886-827-00	BRACKET, SHIELD
46	4-886-828-00	(E,AEP,G-AEP,UK)...COVER, LFT
47	4-886-829-00	INSULATOR, HEAT SINK
48	4-886-830-00	RETAINER, TRANSFORMER
49	4-886-831-00	INSULATOR, HEAT SINK, DIODE
50	4-886-832-00	BRACKET, RADIATION, DIODE
51	4-886-833-00	BRACKET (SMALL), TRANSFORMER
52	4-886-834-00	HEAT SINK
53	4-886-836-00	CHANNEL
54	4-886-837-00	COVER (B), POWER CASE
55	4-886-838-00	COVER (A), POWER CASE
56	4-886-839-00	CASE, P.P.S
57	4-886-840-03	SHEET (FOREIGN), FUNCTION
58	4-886-841-00	PANEL, SUB
59	4-886-842-11	(Canadian)...PLATE, JACK
59	4-886-842-21	(AEP,G-AEP)...PLATE, JACK
59	4-886-842-31	(UK)...PLATE, JACK
59	4-886-842-41	(E1/E2)...PLATE, JACK
60	4-886-844-11	PLATE, BOTTOM
61	4-886-845-01	CASE
62	4-886-846-02	CHASSIS
63	4-886-864-00	SPACER, LED
64	4-886-876-00	ESCUTCHEON, POWER KNOB
65	4-886-005-00	LABEL (FOREIGN)
66	4-886-007-00	PLATE, SHIELD
67	7-682-147-01	SCREW +P 3X6
68	7-682-151-01	SCREW +P 3X14
69	7-682-546-04	SCREW +BVTT 3X5 (S)
70	7-682-949-01	SCREW +PSW 3X10
71	7-685-646-11	SCREW +BVTP 3X8 TYPE2 N-S
72	7-685-851-01	SCREW +BVTT 2X4 (S)
73	7-685-860-04	SCREW +BVTT 2.6X4 (S)
74	7-685-871-01	SCREW +BVTT 3X6 (S)
75	7-685-874-01	SCREW +BVTT 3X12 (S)
76	9-911-842-XX	CUSHION (F)
77	9-911-843-XX	CUSHION, FLYWHEEL
78	9-911-863-XX	(AEP,G-AEP,UK)...INSULATOR (E)
79	9-911-863-XX	(Canadian)...INSULATOR (E)
80	X-4886-405-1	FOOT ASSY
81	X-4886-801-2	KNOB ASSY, CONTROL
82	X-4886-805-0	KNOB (L) ASSY, POWER
83	7-685-876-01	SCREW +BVTT 3X6 (S)
84	9-911-863-XX	(E)...INSULATOR (E)
85	4-874-815-00	CASE, MCLDED
86	X-4886-807-2	PANEL ASSY
87	7-685-645-21	SCREW +BVTP 3X6

NOTE:

- Items with no part number and no description are not stocked because they are seldom required for routine service.
- Items marked with a triangle are not stocked since they are seldom required for routine service. Some delay should be anticipated when ordering these items.
- Due to standardization, parts with part numbers (1-9-911-XX or 9-911-XX-XX) may be different from those used in the set.
- Capacitors and resistors for R channel are omitted. Refer to those for L channel.

CAPACITORS:

- All capacitors are in pF. Common capacitors are omitted. Refer to the following lists for their part numbers. MF: MFD, PF: PFD.

RESISTORS:

- All resistors are in ohms. Common 1/4W, 1/8W and 1/10W carbon resistors are omitted. Refer to the following lists for their part numbers.
- F: nonflammable

COILS

MMF: mH, LH: LH

The components identified by shading and mark  $\Delta$  are critical for safety. Replace only with part number specified.

Les composants identifiés par une trame et une marque  $\Delta$  sont critiques pour la sécurité. Ne les remplacer que par une pièce portant le numéro spécifié.

ACCESSORY & PACKING MATERIAL

No.	Part No.	Description
101	3-701-630-00	BAG, POLYETHYLENE
102	3-773-298-11	(E1/E2).....MANUAL, INSTRUCTION
103	3-773-298-21	(Canadian)...MANUAL, INSTRUCTION, ENGLISH
104	3-773-298-31	(Canadian)...MANUAL, INSTRUCTION, FRENCH
105	3-773-298-41	(AEP).....MANUAL, INSTRUCTION
106	4-875-574-00	SHEET, PROTECTION
107	4-886-231-00	CUSHION (LOWER LEFT)
108	4-886-999-00	CUSHION (LOWER RIGHT)
109	4-886-997-00	CUSHION (UPPER RIGHT)
110	4-886-998-00	CUSHION (UPPER LEFT)
111	4-888-018-00	CARTON

ELECTRICAL PARTS

Ref.No.	Part No.	Description
501	1-217-589-00	CONDUCTOR, CROSS (MELF)
502	▲;1-508-878-00	BASE POST, 3P
503	▲;1-508-879-00	BASE POST
504	▲;1-508-880-00	BASE POST, MCD CONNECTOR 6P
505	▲;1-526-565-00	(E)....AC PLUG ADAPTOR
506	▲;1-533-131-00	HOLDER, FUSE
507	▲;1-535-115-00	(AEP,G-AEP,UK)...TERMINAL
508	▲;1-535-117-00	TERMINAL
509	▲;1-535-118-00	TERMINAL
510	▲;1-535-119-00	TERMINAL
511	▲;1-535-135-00	BASE POST 14MM (10MM PITCH)
512	▲;1-535-136-00	(Canadian)...BASE POST (10MM PITCH)
513	▲;1-535-416-00	(E,AEP,G-AEP,UK)...TERMINAL
514	▲;1-560-200-00	BASE POST, 2P
515	▲;1-560-339-00	PIN, CONNECTOR 9P
516	▲;1-560-598-00	PIN, CONNECTOR 4P
517	▲;1-560-599-00	PIN, CONNECTOR 5P
518	▲;1-560-600-00	PIN, CONNECTOR 6P
519	▲;1-609-418-00	PC BOARD, PPS
520	▲;1-609-480-00	(AEP,G-AEP,UK)...PC BOARD, POWER SUPPLY
520	▲;1-609-481-00	(Canadian).....PC BOARD, POWER SUPPLY
520	▲;1-609-482-00	(E1/E2).....PC BOARD, POWER SUPPLY
521	▲;1-609-483-00	PC BOARD, CONTROL
522	▲;1-609-484-00	PC BOARD, SWITCH
523	▲;1-609-485-00	PC BOARD, INPUT
524	▲;1-609-486-00	PC BOARD, TONE
525	▲;1-609-487-00	PC BOARD, TAPE 2
526	▲;1-609-488-00	PC BOARD, EQUALIZER
527	▲;1-609-489-00	PC BOARD, FUNCTION
528	▲;1-609-490-00	PC BOARD, VOLUME INDICATION
529	▲;1-609-491-00	PC BOARD, SLIDE SWITCH
530	▲;1-609-492-00	PC BOARD, SPEAKER TERMINAL
531	▲;1-609-493-00	PC BOARD, BALANCE VOLUME
532	▲;1-609-494-00	PC BOARD, POWER AMP
533	▲;A-4388-332-A	MOUNTED PCB, POWER
C002	1-108-591-00	CAP, PE TEREPHTHALATE 0.033MF
C003	1-108-579-00	CAP, PE TEREPHTHALATE 0.01MF
C101	1-123-613-00	ELECT 3.3MF 20% 50V
C102	1-108-573-00	MYLAR 0.0056MF 5% 50V
C103	1-108-559-00	MYLAR 0.0015MF 5% 50V
C104	1-123-647-00	ELECT 47MF 20% 6.3V
C105	1-123-613-00	ELECT 3.3MF 20% 50V
C106	1-102-115-00	(G-AEP)...CERAMIC 560PF 5% 50V
C107	1-102-963-00	(Canadian, AEP, E, UK)..... CERAMIC 33PF 5% 50V
C110	1-123-622-00	ELECT 22MF 20% 16V
C111	1-123-622-00	ELECT 22MF 20% 16V
C201	1-130-624-00	FILM 0.022MF 5% 50V

NOTE:

- Items with no part number and no description are not stocked because they are seldom required for routine service.
- Items marked "▲" are not stocked since they are seldom required for routine service. Some delay should be anticipated when ordering these items.
- Due to standardization, parts with part numbers (A-AAA-BBB-XX or A-AAA-BBB-X) may be different from those used in the set.
- Capacitors and resistors for R channel are omitted. Refer to those for L channel.

CAPACITORS:

- All capacitors are in uF. Common capacitors are omitted. Refer to the following lists for their part numbers. MF:uF, PF:uF.

RESISTORS

- All resistors are in ohms. Common 1/4W, 1/8W and 1/16W carbon resistors are omitted. Refer to the following lists for their part numbers.
- F : nonflammable

COILS

- MMH : mH, UH : LH

The components identified by shading and mark ▲ are critical for safety. Replace only with part number specified.

Les composants identifiés par une trame et une marque ▲ sont critiques pour la sécurité. Ne les remplacer que par une pièce portant le numéro spécifié.

ELECTRICAL PARTS

Ref.No.	Part No.	Description			
C202	1-102-973-00	CERAMIC	100PF	5%	50V
C203	1-102-963-00	CERAMIC MELF	33PF	5%	50V
C204	1-123-611-00	ELECT	1MF	20%	50V
C205	1-123-608-00	ELECT	0.22MF	20%	50V
C206	1-123-611-00	ELECT	1MF	20%	50V
C207	1-102-963-00	CERAMIC	33PF	5%	50V
C208	1-123-622-00	ELECT	22MF	20%	16V
C209	1-108-569-00	MYLAR	0.0039MF	5%	50V
C210	1-130-624-00	FILM	0.022MF	5%	50V
C212	1-123-611-00	ELECT	1MF	20%	50V
C213	1-130-622-00	FILM	0.015MF	5%	50V
C214	1-130-632-00	FILM	0.1MF	5%	50V
C215	1-102-074-00	CERAMIC MELF	0.001MF	10%	50V
C216	1-130-632-00	FILM	0.1MF	5%	50V
C217	1-161-053-00	CERAMIC	0.0015MF	20%	50V
C221	1-123-622-00	ELECT	22MF	20%	16V
C222	1-123-622-00	ELECT	22MF	20%	16V
C223	1-102-963-00	(AEP, Canadian, E, UK) ... CERAMIC	33PF	5%	50V
C223	1-102-976-00	(G-AEP) ... CERAMIC	180PF	5%	50V
C301	1-123-616-00	ELECT	4.7MF	20%	25V
C303	1-123-617-00	ELECT	10MF	20%	16V
C304	1-101-361-00	(AEP, Canadian, E, UK) ... CERAMIC	150PF	5%	50V
C304	1-102-973-00	(G-AEP) ... CERAMIC	100PF	5%	50V
C305	1-123-465-00	ELECT	220MF	20%	6.3V
C306	1-123-611-00	ELECT	1MF	20%	50V
C307	1-108-377-00	MYLAR	0.01MF	10%	100V
C308	1-108-839-00	MYLAR	0.015MF	10%	50V
C309	1-123-622-00	ELECT	22MF	20%	16V
C310	1-101-001-00	CERAMIC	0.001MF		50V
C311	1-108-843-00	MYLAR	0.033MF	10%	50V
C312	1-123-821-11	ELECT	47MF	20%	16V
C313	1-102-973-00	CERAMIC	100PF	5%	50V
C314	1-102-973-00	CERAMIC	100PF	5%	50V
C315	1-102-963-00	(G-AEP) ... CERAMIC	33PF	5%	50V
C316	1-108-579-00	(G-AEP) ... MYLAR	0.01MF	5%	50V
C317	1-108-579-00	(G-AEP) ... MYLAR	0.01MF	5%	50V
C330	1-123-617-00	ELECT	10MF	20%	16V
C331	1-123-474-00	ELECT	100MF	20%	10V
C332	1-123-617-00	ELECT	10MF	20%	16V
C333	1-123-474-00	ELECT	100MF	20%	10V
C401	1-102-110-00	(G-AEP) ... CERAMIC	220PF	10%	50V
C402	1-102-110-00	(G-AEP) ... CERAMIC	220PF	10%	50V
C403	1-102-110-00	(G-AEP) ... CERAMIC	220PF	10%	50V
C404	1-102-110-00	(G-AEP) ... CERAMIC	220PF	10%	50V
C405	1-102-978-00	(G-AEP) ... CERAMIC	220PF	5%	50V
C406	1-123-611-00	ELECT	1MF	20%	50V
C407	1-123-611-00	ELECT	1MF	20%	50V

ELECTRICAL PARTS

Ref.No.	Part No.	Description			
C408	1-123-611-00	ELECT	1MF	20%	50V
C409	1-102-074-00	CERAMIC	0.001MF	10%	50V
C410	1-102-074-00	CERAMIC	0.001MF	10%	50V
C411	1-161-323-00	CERAMIC	0.001MF	10%	50V
C412	1-102-074-00	CERAMIC	0.001MF	10%	50V
C413	1-161-323-00	CERAMIC	0.001MF	10%	50V
C414	1-123-617-00	ELECT	10MF	20%	16V
C415	1-123-614-00	ELECT	3.3MF	20%	35V
C416	1-123-617-00	ELECT	10MF	20%	16V
C417	1-123-489-00	ELECT	2200MF	20%	16V
C418	1-123-617-00	ELECT	10MF	20%	16V
C419	1-123-611-00	ELECT	1MF	20%	50V
C420	1-101-001-00	CERAMIC	0.001MF		50V
C601	1-123-622-00	ELECT	22MF	20%	16V
C602	1-123-622-00	ELECT	22MF	20%	16V
C701	1-102-114-00	CERAMIC	470PF	10%	50V
C702	1-102-114-00	CERAMIC	470PF	10%	50V
C703	1-123-617-00	ELECT	1000MF	20%	50V
C704	1-123-517-00	ELECT	1000MF	20%	50V
C705	1-123-380-00	ELECT	1MF	20%	100V
C706	1-123-918-00	ELECT	2200MF	20%	25V
C707	1-123-918-00	ELECT	2200MF	20%	25V
C708	1-123-608-00	ELECT	0.22MF	20%	50V
C709	1-123-608-00	ELECT	0.22MF	20%	50V
C801	▲ 1-130-234-00	(E) ... CAP, FILM	0.047MF		300V
C801	▲ 1-130-701-00	(AEP, G-AEP, UK) ... CERAMIC	0.47MF	20%	300V
C801	▲ 1-161-746-00	(Canadian) ... CERAMIC	0.001MF	20%	125V
C802	▲ 1-123-505-00	ELECT	220MF	20%	35V
C803	▲ 1-125-277-00	(E1/E2) ... ELECT (BLOCK)	470MF	20%	200V
C803	▲ 1-125-326-00	(AEP, G-AEP, UK) ... CAP ELECT	820MF	20%	400V
C803	▲ 1-125-327-00	(Canadian) ... CAP ELECT	820PF	20%	200V
C804	▲ 1-161-736-00	(E1/E2) ... CERAMIC	470PF	20%	400V
C804	▲ 1-161-737-00	(AEP, G-AEP, UK) ... CERAMIC	0.001MF	20%	400V
C804	▲ 1-161-745-00	(Canadian) ... CERAMIC	470PF	10%	125V
C805	▲ 1-161-736-00	(E1/E2) ... CERAMIC	470PF	20%	400V
C805	▲ 1-161-737-00	(AEP, G-AEP, UK) ... CERAMIC	0.001MF	20%	400V
C805	▲ 1-161-745-00	(Canadian) ... CERAMIC	470PF	10%	125V
C806	▲ 1-161-736-00	(E1/E2) ... CERAMIC	470PF	20%	400V
C806	▲ 1-161-737-00	(AEP, G-AEP, UK) ... CERAMIC	0.001MF	20%	400V
C806	▲ 1-161-745-00	(Canadian) ... CERAMIC	470PF	10%	125V
C807	▲ 1-161-736-00	(E1/E2) ... CERAMIC	470PF	20%	400V
C807	▲ 1-161-737-00	(AEP, G-AEP, UK) ... CERAMIC	0.001MF	20%	400V
C807	▲ 1-161-745-00	(Canadian) ... CERAMIC	470PF	10%	125V
C808	▲ 1-161-737-00	(AEP, G-AEP, UK, E1, E2) ... CERAMIC	0.001MF	20%	400V
C808	▲ 1-161-746-00	(Canadian) ... CERAMIC	0.001MF	10%	125V

NOTE:

- Items with no part number and no description are not stocked because they are seldom required for routine service.
- Items marked "▲" are not stocked since they are seldom required for routine service. Some delay should be anticipated when ordering these items.
- Due to standardization, parts with part numbers (G-100-XXX-XX or A-1000-XXX-X) may be different from those used in the set.
- Capacitors and resistors for R channel are omitted. Refer to those for L channel.

CAPACITORS:

- All capacitors are in pF. Common capacitors are omitted. Refer to the following lists for their part numbers. MF: pF, PF: pF.

RESISTORS

- All resistors are in ohms. Common 1/4W, 1/8W and 1/16W carbon resistors are omitted. Refer to the following lists for their part numbers.

F : nonflammable

COILS

MMH : mH, UH :  $\mu$ H

The components identified by shading and mark ▲ are critical for safety. Replace only with part number specified.

Les composants identifiés par une trame et une marque ▲ sont critiques pour la sécurité. Ne les remplacer que par une pièce portant le numéro spécifié.



## ELECTRICAL PARTS

Ref.No.	Part No.	Description			
C809	▲.1-161-737-00	(AEP,G-AEP,UK,E1,E2) ...CERAMIC	0.001MF	20%	400V
C809	▲.1-161-746-00	(Canadian)...CERAMIC	0.001MF	10%	125V
C810	▲.1-161-737-00	(AEP,G-AEP,UK,E1,E2) ...CERAMIC	0.001MF	20%	400V
C810	▲.1-161-746-00	(Canadian)...CERAMIC	0.001MF	10%	125V
C811	▲.1-161-737-00	(AEP,G-AEP,UK,E1,E2) ...CERAMIC	0.001MF	20%	400V
C811	▲.1-161-746-00	(Canadian)...CERAMIC	0.001MF	10%	125V
C812	▲.1-125-277-00	(E1/E2)...ELECT(BLOCK)	470MF	20%	200V
C812	▲.1-161-737-00	(AEP,G-AEP,UK).CERAMIC	0.001MF	20%	400V
C813	▲.1-161-737-00	(AEP,G-AEP,UK).CERAMIC	0.001MF	20%	400V
C814	▲.1-161-737-00	(AEP,G-AEP,UK).CERAMIC	0.001MF	20%	400V
C815	▲.1-161-737-00	(AEP,G-AEP,UK).CERAMIC	0.001MF	20%	400V
C901	▲.1-130-141-00	MYLAR	0.01MF	20%	630V
C902	▲.1-161-741-00	(E1/E2)...CERAMIC	0.001MF	10%	400V
C902	▲.1-161-734-00	(AEP,G-AEP,UK).CERAMIC	0.0022MF	20%	400V
C902	▲.1-161-746-00	(Canadian)...CERAMIC	0.001MF	10%	125V
C903	▲.1-161-741-00	(E1/E2)...CERAMIC	0.001MF	10%	400V
C903	▲.1-161-734-00	(AEP,G-AEP,UK).CERAMIC	0.0022MF	20%	400V
C903	▲.1-161-746-00	(Canadian)...CERAMIC	0.001MF	10%	125V
C904	▲.1-124-318-51	(E1/E2,AEP,UK)...ELECT	2.2MF		400V
C904	▲.1-123-938-00	(Canadian)...CAP, ELECT	4.7MF	20%	200V
C905	▲.1-124-319-51	(E1/E2,AEP,UK)...ELECT	15MF		400V
C905	▲.1-123-942-51	(Canadian)...CAP, ELECT	47MF	20%	200V
C906	▲.1-130-533-00	(E1/E2,AEP,UK)...MYLAR	0.39MF	10%	250V
C906	▲.1-130-358-00	(Canadian)...MYLAR	1.2MF	10%	250V
C907	▲.1-130-533-00	(E1/E2,AEP,UK)...MYLAR	0.39MF	10%	250V
C907	▲.1-130-358-00	(Canadian)...MYLAR	1.2MF	10%	250V
C908	▲.1-108-595-00	MYLAR	0.047MF	5%	50V
C909	▲.1-108-599-00	MYLAR	0.068MF	5%	50V
C910	▲.1-123-516-00	ELECT	470MF	20%	50V
C911	▲.1-123-516-00	ELECT	470MF	20%	50V
C912	▲.1-123-513-00	ELECT	100MF	20%	50V
C913	▲.1-123-513-00	ELECT	100MF	20%	50V
C914	▲.1-123-497-00	ELECT	470MF	20%	25V
C915	▲.1-123-497-00	ELECT	470MF	20%	25V
C916	▲.1-123-495-00	ELECT	220MF	20%	25V
C917	▲.1-123-495-00	ELECT	220MF	20%	25V
C918	▲.1-161-734-00	(AEP,G-AEP,UK).CERAMIC	0.0022MF	20%	400V
C919	▲.1-161-734-00	(AEP,G-AEP,UK).CERAMIC	0.0022MF	20%	400V
C920	▲.1-130-141-00	(E1/E2)...MYLAR	0.01MF	20%	630V
CN801	▲.1-526-695-00	(E,US)...OUTLET, AC			(2 GANG)
CN801	▲.1-526-694-00	(AEP,G-AEP)...OUTLET, AC			
CN801	▲.1-526-883-00	(Canadian)...OUTLET, AC			(2 GANG)
CN801	▲.1-526-751-00	(UK)...OUTLET, AC			

## ELECTRICAL PARTS

Ref.No.	Part No.	Description
CNP801	▲.1-551-628-00	(Canadian)...CORD, POWER
CNP801	▲.1-551-908-00	(AEP,G-AEP)...CORD, POWER
CNP801	▲.1-551-884-00	(UK)...CORD, POWER
CNP801	▲.1-551-472-00	(E)...CORD, POWER
D301	8-719-815-55	DIODE 1S1555
D302	8-719-815-55	DIODE 1S1555
D303	8-719-815-55	DIODE 1S1555
D304	8-719-947-10	DIODE 1S2471VE
D305	8-719-107-57	DIODE 1S953-7
D306	8-719-815-55	DIODE 1S1555
D307	8-719-815-55	DIODE 1S1555
D308	8-719-910-52	DIODE HZ15-2L
D309	8-719-815-55	DIODE 1S1555
D312	8-719-815-55	DIODE 1S1555
D313	8-719-910-29	DIODE HZ12C3L
D314	8-719-815-55	DIODE 1S1555
D364	8-719-815-55	DIODE 1S1555
D401	8-719-815-55	DIODE 1S1555
D402	8-719-107-57	DIODE 1S953-7
D403	8-719-107-57	DIODE 1S953-7
D404	8-719-907-26	DIODE GL-5PG21
D405	8-719-907-26	DIODE GL-5PG21
D406	8-719-907-26	DIODE GL-5PG21
D407	8-719-907-26	DIODE GL-5PG21
D408	8-719-907-26	DIODE GL-5PG21
D409	8-719-800-14	DIODE TL6G163
D501	8-719-822-55	DIODE TLG205-5
D502	8-719-822-55	DIODE TLG205-5
D509	8-719-910-66	DIODE HZ6B3L
D510	8-719-910-74	DIODE HZ7B1L
D511	8-719-000-12	DIODE MC931
D701	8-719-000-06	DIODE MC921
D702	8-719-000-04	DIODE MC911
D707	8-719-230-24	DIODE 30DL4
D708	8-719-230-24	DIODE 30DL4
D801	▲.8-719-230-24	DIODE 30DL4
D802	▲.8-719-230-24	DIODE 30DL4
D803	▲.8-719-230-24	DIODE 30DL4
D804	▲.8-719-230-24	DIODE 30DL4
D901	▲.8-719-923-48	DIODE 1S2348H
D902	▲.8-719-923-48	DIODE 1S2348H
D903	▲.8-719-300-22	DIODE CTU-22U
D904	▲.8-719-300-22	DIODE CTU-22U
D905	▲.8-719-300-22	DIODE CTU-22U
D906	▲.8-719-300-22	DIODE CTU-22U

## NOTE:

- Items with no part number and no description are not stocked because they are seldom required for routine service.
- Items marked "▲" are not stocked since they are seldom required for routine service. Some delay should be anticipated when ordering these items.
- Due to standardization, parts with part numbers (E-BAC-BAC-XX or A-BAC-A-BAC-X) may be different from those used in the set.
- Capacitors and resistors for R channel are omitted. Refer to those for L channel.

## CAPACITORS:

- All capacitors are in  $\mu$ F. Common capacitors are omitted. Refer to the following lists for their part numbers.  
MF: $\mu$ F, PF: $\mu$ F.

## RESISTORS

- All resistors are in ohms. Common 1/4W, 1/8W and 1/16W carbon resistors are omitted. Refer to the following lists for their part numbers.

F: nonflammable

## COILS

- MMH: mH, UH:  $\mu$ H

The components identified by shading and mark ▲ are critical for safety. Replace only with part number specified.

Les composants identifiés par une trame et une marque ▲ sont critiques pour la sécurité. Ne les remplacer que par une pièce portant le numéro spécifié.

ELECTRICAL PARTS

Ref.No.	Part No.	Description
F801	1-532-203-11	(AEP, G-AEP, UK)... FUSE, TIME-LAG
F801	1-532-359-00	(E)... FUSE, TIME-LAG
F801	1-532-579-11	(US, Canadian)... FUSE, TIME-LAG
F802	1-432-556-00	FUSE, TEMPERATURE
IB901A	1-252-052-00	COMPOSITION CIRCUIT BLOCK
IC101	8-759-935-58	IC TL4558P-B
IC201	8-759-935-58	IC TL4558P-B
IC301	8-759-100-03	IC CX20007-1
IC302	8-759-320-02	IC HAI2002
IC351	8-759-100-03	IC CX20007-1
IC401	8-759-800-37	IC LC4066BH
IC402	8-759-800-33	IC LC7815H
IC601	8-759-171-12	IC UPC7812H
IC602	8-759-979-12	IC UA7912UC
IC701	8-759-745-61	IC NJM45600-D
J101	1-507-741-21	JACK, PIN 6P
J102	1-507-741-21	JACK, PIN 6P
J103	1-507-741-21	JACK, PIN 6P
J104	1-507-741-21	JACK, PIN 6P
J105	1-507-741-21	JACK, PIN 6P
J106	1-507-741-21	JACK, PIN 6P
J201	1-507-735-00	JACK (LARGE TYPE)
J301	1-507-707-00	JACK, LARGE TYPE
L301	1-420-872-00	COIL, AIR CORE
L351	1-420-872-00	COIL, AIR CORE
L801	1-421-340-00	(E1/E2, AEP, G-AEP, UK)... FILTER, LINE
L801	1-421-580-00	(Canadian)... FILTER, LINE
L802	1-421-329-00	COIL, CHOKE
L803	1-421-329-00	COIL, CHOKE
L804	1-421-329-00	COIL, CHOKE
L805	1-421-329-00	COIL, CHOKE
L900	1-421-461-00	COIL, CHOKE
L901	1-421-340-00	(E1/E2, AEP, G-AEP, UK)... FILTER, LINE
L901	1-421-580-00	(Canadian)... FILTER, LINE
L902	1-421-461-00	COIL, CHOKE
L903	1-421-461-00	COIL, CHOKE
L904	1-421-461-00	COIL, CHOKE
L907	1-421-461-00	COIL, CHOKE
L909	1-421-461-00	COIL, CHOKE
PTH301	1-800-427-00	POSTISTOR
Q201	8-729-902-11	TRANSISTOR 2SC2021
Q202	8-751-710-00	TRANSISTOR 2SC1637
Q301	8-729-102-47	TRANSISTOR 2SA1232

ELECTRICAL PARTS

Ref.No.	Part No.	Description
Q302	8-729-102-57	TRANSISTOR 2SC3012
Q303	8-729-245-83	TRANSISTOR 2SC2458
Q304	8-729-612-77	TRANSISTOR 2SA1027R
Q305	8-729-245-83	TRANSISTOR 2SC2458
Q306	8-729-117-54	TRANSISTOR 2SA1175
Q403	8-729-993-72	TRANSISTOR 2SA937-R
Q501	8-729-180-93	TRANSISTOR 2SD809
Q502	8-729-173-13	TRANSISTOR 2SB731
Q503	8-729-902-11	TRANSISTOR 2SC2021
Q504	8-729-993-72	TRANSISTOR 2SA937
Q505	8-729-967-32	TRANSISTOR 2SC2673
Q701	8-729-156-81	TRANSISTOR 2SD568
Q702	8-729-374-02	TRANSISTOR 2SB740
Q703	8-729-902-11	TRANSISTOR 2SC2021
Q704	8-729-993-72	TRANSISTOR 2SA937
Q705	8-729-177-43	TRANSISTOR 2SD774
Q706	8-729-170-71	TRANSISTOR 2SB707
Q901	8-729-602-67	TRANSISTOR 2SA1026-7
Q902	8-729-663-47	TRANSISTOR 2SC1364
Q903	X-4869-209-1	(E, AEP, G-AEP, UK)... TRANSISTOR ASSY, 2X2SC2542'S
Q903	X-4886-815-1	(Canadian)... TRANSISTOR ASSY, 2X2SC2768A'S
Q904	X-4886-815-1	(Canadian)... TRANSISTOR ASSY, 2X2SC2768A'S
Q904	X-4869-209-1	(E, AEP, G-AEP, UK)... TRANSISTOR ASSY, 2X2SC2542'S
R101	1-246-513-00	CARBON 47K 5% 1/4W
R102	1-246-539-00	CARBON 560K 5% 1/4W
R103	1-246-473-00	CARBON 1K 5% 1/4W
R104	1-246-473-00	CARBON 1K 5% 1/4W
R105	1-246-539-00	CARBON 560K 5% 1/4W
R106	1-246-513-00	CARBON 47K 5% 1/4W
R107	1-246-473-00	CARBON 1K 5% 1/4W
R108	1-246-521-00	CARBON 100K 5% 1/4W
R201	1-246-517-00	CARBON 68K 5% 1/4W
R202	1-246-481-00	CARBON 2.2K 5% 1/4W
R203	1-246-491-00	CARBON 5.6K 5% 1/4W
R204	1-246-509-00	CARBON 33K 5% 1/4W
R205	1-246-521-00	CARBON 100K 5% 1/4W
R206	1-246-541-00	CARBON 680K 5% 1/4W
R207	1-246-473-00	CARBON 1K 5% 1/4W
R208	1-246-545-00	CARBON 1M 5% 1/4W
R209	1-246-489-00	CARBON 4.7K 5% 1/4W
R210	1-246-473-00	CARBON 1K 5% 1/4W

NOTE:

- Items with no part number and no description are not stocked because they are seldom required for routine service.
- Items marked "●" are not stocked since they are seldom required for routine service. Some delay should be anticipated when ordering these items.
- Due to standardization, parts with part numbers (G-AAA-AAA-XX or A-AAA-AAA-X) may be different from those used in the set.
- Capacitors and resistors for R channel are omitted. Refer to those for L channel.

CAPACITORS:

- All capacitors are in  $\mu$ F. Common capacitors are omitted. Refer to the following lists for their part numbers.
- MF:  $\mu$ F, PF:  $\mu$ PF.

RESISTORS

- All resistors are in ohms. Common 1/4W, 1/8W and 1/16W carbon resistors are omitted. Refer to the following lists for their part numbers.

F: nonflammable

COILS

MMH: mH, UH:  $\mu$ H

The components identified by shading and mark  $\Delta$  are critical for safety. Replace only with part number specified.

Les composants identifiés par une trame et une marque  $\Delta$  sont critiques pour la sécurité. Ne les remplacer que par une pièce portant le numéro spécifié.

ELECTRICAL PARTS

Ref.No.	Part No.	Description				
R211	1-246-509-00	CARBON	33K	5%	1/4W	
R212	1-246-503-00	CARBON	18K	5%	1/4W	
R213	1-246-541-00	CARBON	680K	5%	1/4W	
R215	1-246-487-00	CARBON	3.9K	5%	1/4W	
R216	1-246-469-00	CARBON	680	5%	1/4W	
R217	1-246-505-00	CARBON	22K	5%	1/4W	
R218	1-246-437-00	CARBON	3.9K	5%	1/4W	
R219	1-246-481-00	CARBON	2.2K	5%	1/4W	
R301	1-246-473-00	CARBON	1K	5%	1/4W	
R302	1-247-173-00	CARBON	47K	5%	1/4W	
R303	1-247-173-00	CARBON	47K	5%	1/4W	
R304	1-247-517-	CARBON	1.5K	5%	1/4W	
R305	1-247-143-00	CARBON	3.3K	5%	1/4W	
R306	1-246-473-00	CARBON	1K	5%	1/4W	
R307	1-247-127-00	CARBON	680	5%	1/4W	
R308	1-246-483-00	CARBON	2.7K	5%	1/4W	
R309	▲ 1-212-986-00	FUSIBLE	150	5%	1/2W	F
R310	▲ 1-212-986-00	FUSIBLE	150	5%	1/2W	F
R312	▲ 1-247-125-00	CARBON	560	5%	1/4W	F
R313	▲ 1-247-125-00	CARBON	560	5%	1/4W	F
R314	1-217-151-00	RES, METAL PLATE	0.22			
R315	1-217-151-00	RES, METAL PLATE	0.22			
R316	▲ 1-217-389-00	FUSIBLE	15	5%	1/4W	F
R317	▲ 1-212-962-00	FUSIBLE	15	5%	1/2W	F
R318	1-246-473-00	CARBON	1K	5%	1/4W	
R319	1-247-541-00	CARBON	1.5K	5%	1/4W	
R320	1-217-611-00	RES, METAL PLATE	0.1			
R321	▲ 1-212-958-00	FUSIBLE	10	5%	1/2W	F
R322	▲ 1-247-192-00	CARBON	10	5%	1/2W	F
R323	▲ 1-247-232-00	CARBON	470	5%	1/2W	F
R324	1-246-509-00	CARBON	33K	5%	1/4W	
R325	1-247-163-00	CARBON	22K	5%	1/4W	
R326	1-247-173-00	CARBON	47K	5%	1/4W	
R327	▲ 1-212-958-00	(G-AEP)...FUSIBLE	10	5%	1/2W	
R328	▲ 1-212-958-00	(G-AEP)...FUSIBLE	10	5%	1/2W	
R331	▲ 1-247-238-00	CARBON	820	5%	1/2W	F
R332	1-247-561-00	CARBON	100K	5%	1/4W	
R333	1-247-561-00	CARBON	100K	5%	1/4W	
R334	1-247-539-00	CARBON	12K	5%	1/4W	
R335	1-247-137-00	CARBON	1.8K	5%	1/4W	
R336	1-247-561-00	CARBON	100K	5%	1/4W	
R337	▲ 1-213-145-00	METAL OXIDE	1.5K	5%	1W	F
R338	1-247-561-00	CARBON	100K	5%	1/4W	
R339	1-247-143-00	CARBON	3.3K	5%	1/4W	

ELECTRICAL PARTS

Ref.No.	Part No.	Description				
R401	1-246-461-00	(G-AEP)...CARBON	330	5%	1/4W	
R402	1-246-465-00	(G-AEP)...CARBON	470	5%	1/4W	
R403	1-246-465-00	(G-AEP)...CARBON	470	5%	1/4W	
R404	1-246-465-00	(G-AEP)...CARBON	470	5%	1/4W	
R405	1-246-465-00	(G-AEP)...CARBON	470	5%	1/4W	
R406	1-246-489-00	CARBON	4.7K	5%	1/4W	
R407	1-246-465-00	(G-AEP)...CARBON	470	5%	1/4W	
R408	1-246-477-00	CARBON	1.5K	5%	1/4W	
R409	1-246-539-00	CARBON	560K	5%	1/4W	
R410	1-246-477-00	CARBON	1.5K	5%	1/4W	
R411	1-246-539-00	CARBON	560K	5%	1/4W	
R412	1-246-539-00	CARBON	560K	5%	1/4W	
R413	1-246-477-00	CARBON	1.5K	5%	1/4W	
R414	1-246-539-00	CARBON	560K	5%	1/4W	
R415	1-246-477-00	CARBON	1.5K	5%	1/4W	
R416	1-246-477-00	CARBON	1.5K	5%	1/4W	
R417	1-246-477-00	CARBON	1.5K	5%	1/4W	
R418	1-246-477-00	CARBON	1.5K	5%	1/4W	
R419	1-246-539-00	CARBON	560K	5%	1/4W	
R420	1-246-539-00	CARBON	560K	5%	1/4W	
R421	1-246-539-00	CARBON	560K	5%	1/4W	
R422	1-246-539-00	CARBON	560K	5%	1/4W	
R423	1-246-521-00	CARBON	100K	5%	1/4W	
R424	1-246-473-00	CARBON	1K	5%	1/4W	
R425	1-246-521-00	CARBON	100K	5%	1/4W	
R426	1-246-489-00	CARBON	4.7K	5%	1/4W	
R427	1-246-489-00	CARBON	4.7K	5%	1/4W	
R428	1-246-489-00	CARBON	4.7K	5%	1/4W	
R429	1-246-489-00	CARBON	4.7K	5%	1/4W	
R430	1-246-489-00	CARBON	4.7K	5%	1/4W	
R431	1-246-489-00	CARBON	4.7K	5%	1/4W	
R432	1-246-489-00	CARBON	4.7K	5%	1/4W	
R433	1-246-489-00	CARBON	4.7K	5%	1/4W	
R434	1-246-529-00	CARBON	220K	5%	1/4W	
R435	1-246-545-00	CARBON	1M	5%	1/4W	
R436	1-246-449-00	CARBON	100	5%	1/4W	
R437	1-246-505-00	CARBON	22K	5%	1/4W	
R438	1-246-513-00	CARBON	47K	5%	1/4W	
R439	1-246-505-00	CARBON	22K	5%	1/4W	
R443	1-246-473-00	CARBON	1K	5%	1/4W	
R456	1-246-489-00	CARBON	4.7K	5%	1/4W	
R501	1-246-481-00	CARBON	2.2K	5%	1/4W	
R502	1-246-481-00	CARBON	2.2K	5%	1/4W	
R503	▲ 1-206-479-00	METAL OXIDE	47	5%	2W	F
R504	▲ 1-206-479-00	METAL OXIDE	47	5%	2W	F

NOTE:

- Items with no part number and no description are not stocked because they are seldom required for routine service.
- Items marked "▲" are not stocked since they are seldom required for routine service. Some delay should be anticipated when ordering these items.
- Due to standardization, parts with part numbers (E-311-300-XX or A-3111-301-X) may be different from those used in the set.
- Capacitors and resistors for R channel are omitted. Refer to those for L channel.

CAPACITORS:

- All capacitors are in pF. Common capacitors are omitted. Refer to the following lists for their part numbers. MF:LF, PF:LF.

RESISTORS

- All resistors are in ohms. Common 1/4W, 1/8W and 1/16W carbon resistors are omitted. Refer to the following lists for their part numbers.

F : nonflammable

COILS

MH : mH, UH : LH

The components identified by shading and mark ▲ are critical for safety. Replace only with part number specified.

Les composants identifiés par une trame et une marque ▲ sont critiques pour la sécurité. Ne les remplacer que par une pièce portant le numéro spécifié.

ELECTRICAL PARTS

Ref.No.	Part No.	Description			
R505	1-246-497-00	CARBON	10K	5%	1/4W
R506	1-246-445-00	CARBON	68	5%	1/4W
R507	1-246-473-00	CARBON	1K	5%	1/4W
R508	1-246-417-00	CARBON	4.7	5%	1/4W
R509	1-246-417-00	CARBON	4.7	5%	1/4W
R510	1-246-521-00	CARBON	100K	5%	1/4W
R701	1-246-493-00	CARBON	6.8K	5%	1/4W
R702	1-246-515-00	CARBON	56K	5%	1/4W
R703	1-246-497-00	CARBON	10K	5%	1/4W
R704	1-246-493-00	CARBON	6.8K	5%	1/4W
R705	1-246-515-00	CARBON	56K	5%	1/4W
R706	1-246-497-00	CARBON	10K	5%	1/4W
R707	1-246-495-00	CARBON	8.2K	5%	1/4W
R708	1-246-497-00	CARBON	10K	5%	1/4W
R709	1-246-497-00	CARBON	10K	5%	1/4W
R710	1-246-489-00	CARBON	4.7K	5%	1/4W
R711	1-246-489-00	CARBON	4.7K	5%	1/4W
R712	1-246-505-00	CARBON	22K	5%	1/4W
R713	1-246-505-00	CARBON	22K	5%	1/4W
R714	1-246-505-00	CARBON	22K	5%	1/4W
R715	1-246-480-00	CARBON	2K	5%	1/4W
R716	1-246-480-00	CARBON	2K	5%	1/4W
R717	1-246-505-00	CARBON	22K	5%	1/4W
R718	1-247-107-00	CARBON	100	5%	1/4W F
R719	1-247-107-00	CARBON	100	5%	1/4W F
R801	1-247-242-00	CARBON	1.2K	5%	1/2W F
R802	1-205-599-00	(E1/E2,AEP,G-AEP,UK)..CEMENTED	75	10%	5W
R802	1-205-681-00	(Canadian).....CEMENTED	33	10%	5W
R803	1-246-529-00	(E1/E2).....CARBON	220K	5%	1/4W
R803	1-246-543-00	(AEP,G-AEP,UK)..CARBON	820K	5%	1/4W
R804	1-246-529-00	(E1/E2).....CARBON	220K	5%	1/4W
R901	1-244-927-51	(E1/E2,AEP,G-AEP,UK)..CARBON	180K	5%	1/2W
R901	1-246-520-00	(Canadian).....CARBON	91K	5%	1/4W
R906	1-206-480-00	(E1/E2,AEP,G-AEP,UK)..METAL OXIDE	51	5%	2W F
RV201	1-228-451-00	RES, VAR, CARBON (WITH SW)	100K X2		
RV202	1-228-931-00	RES, VAR, SLIDE	250K		
RV203	1-228-380-00	RES, VAR, SLIDE	100K		
RV204	1-228-380-00	RES, VAR, SLIDE	100K		
RV301	1-226-237-00	RES, ADJ, CARBON	20K		
RY301	1-515-437-00	RELAY			
RY801	1-515-347-00	RELAY			

ELECTRICAL PARTS

Ref.No.	Part No.	Description
S1	1-554-393-00	SWITCH, PUSH (3 KEY)
S2	1-554-393-00	SWITCH, PUSH (3 KEY)
S3	1-554-393-00	SWITCH, PUSH (3 KEY)
S4	1-554-393-00	SWITCH, KEY BOARD
S5	1-554-393-00	SWITCH, KEY BOARD
S6	1-554-393-00	SWITCH, KEY BOARD
S7	1-554-393-00	SWITCH, KEY BOARD
S8	1-554-393-00	SWITCH, KEY BOARD
S9	1-554-391-00	SWITCH, SLIDE
S10	1-553-739-21	SWITCH, KEY BOARD
S11	1-553-739-21	SWITCH, KEY BOARD
S12	1-554-392-00	SWITCH, PUSH (2 KEY)
S13	1-554-392-00	SWITCH, PUSH (2 KEY)
S14	1-553-317-00	(E).....SWITCH, PUSH (AC POWER)
S14	1-553-319-12	(US,Canadian)..SWITCH, PUSH (AC POWER)
S14	1-553-447-11	(AEP,G-AEP,UK)..SWITCH, PUSH (AC POWER)
T901	1-543-098-00	CORE
T901	1-543-100-00	CORE
T902	1-543-100-00	CORE
T903	1-447-493-00	(Canadian).....TRANSFORMER, CONVERTER
T903	1-447-494-00	(E1/E2,AEP,G-AEP,UK)..TRANSFORMER, CONVERTER
TM301	1-536-773-00	TERMINAL BOARD (SPEAKER) 8P
VS801	1-526-576-31	(E).....SELECTOR, POWER VOLTAGE

NOTE:

- Items with no part number and no description are not stocked because they are seldom required for routine service.
- Items marked "▲" are not stocked since they are seldom required for routine service. Some delay should be anticipated when ordering these items.
- Due to standardization, parts with part numbers (E-2000-200-XX or E-2000-200-X) may be different from those used in the set.
- Capacitors and resistors for R channel are omitted. Refer to those for L channel.

CAPACITORS:

- All capacitors are in μF. Common capacitors are omitted. Refer to the following lists for their part numbers. MF:μF, PF:pF.

RESISTORS

- All resistors are in ohms. Common 1/4W, 1/8W and 1/16W carbon resistors are omitted. Refer to the following lists for their part numbers.

F : nonflammable

COILS

- MMH : mH, UH : μH

The components identified by shading and mark ▲ are critical for safety. Replace only with part number specified.

Les composants identifiés par une trame et une marque ▲ sont critiques pour la sécurité. Ne les remplacer que par une pièce portant le numéro spécifié.

**HARDWARE NOMENCLATURE**

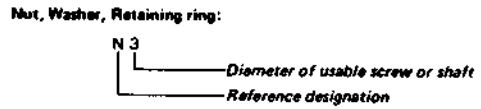
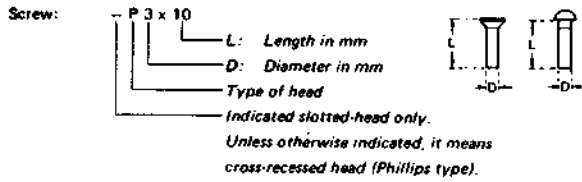

Reference Designation	Shape	Description	Remarks
<b>SCREWS</b>			
P		pan-head screw	binding-head (B) screw for replacement
PWH		pan-head screw with washer face	binding-head (B) screw and flat washer for replacement
PS PSP		pan-head screw with spring washer	binding-head (B) screw and spring washer for replacement
PSW PSPW		pan-head screw with spring and flat washers	binding-head (B) screw and spring and flat washers for replacement
R		round-head screw	binding-head (B) screw for replacement
K		flat-countersunk-head screw	
RK		oval-countersunk-head screw	
B		binding-head screw	
T		truss-head screw	binding-head (B) screw for replacement
F		flat-fillister-head screw	
RF		fillister-head screw	
BV		brazer-head screw	

Reference Designation	Shape	Description	Remarks
<b>SELF-TAPPING SCREWS</b>			
TA		self-tapping screw	ex: TA, P 3 x 10
PTP		pan-head self-tapping screw	binding-head self-tapping (TA, B) screw for replacement
PTPWH		pan-head self-tapping screw with washer face	binding-head self-tapping (TA, B) screw and flat washer for replacement
PTTWH		pan-head thread-rolling screw with washer face	binding-head (B) screw and flat washer for replacement
<b>SET SCREWS</b>			
SC		set screw	
SC		hexagon-socket set screw	ex: SC 2.6 x 4, hexagon socket
<b>NUT</b>			
N		nut	
<b>WASHERS</b>			
W		flat washer	
SW		spring washer	
LW		internal-tooth lock washer	ex: LW3, internal
LW		external-tooth lock washer	ex: LW3, external
<b>RETAINING RINGS</b>			
E		retaining ring	
G		grip-type retaining ring	