

TA-FA5ES/FA7ES

SERVICE MANUAL

AEP Model



Photo: TA-FA7ES (Black)

SPECIFICATIONS

System

Power Amplifier: Pure-complementary SEPP MOS
FET power amplifier with all stages directly coupled
Preamplifier: Low-noise, high-gain equalizer amplifier
Power section: Large-capacity power supply advanced
STD

Rated output

TA-FA7ES
4 ohms, 150 W + 150 W (DIN 0.7%)
8 ohms, 100 W + 100 W (DIN 0.7%)
TA-FA5ES
4 ohms, 135 W + 135 W (DIN 0.7%)
8 ohms, 90 W + 90 W (DIN 0.7%)

Speakers impedance

4 to 16 ohms

Output bandwidth (8 ohms)

10 Hz to 100 kHz (at 40 W output, and
high-frequency distortion rate of
0.08%)

Dynamic headroom

at 4 ohms: TA-FA7ES 2 dB
TA-FA5ES 3 dB
at 8 ohms: TA-FA7ES 1.2 dB
TA-FA5ES 2 dB

Total harmonic distortion

0.005% (at 8 ohms, 10 W output)

Damping factor

100 (8 ohms, 1 kHz)

Intermodulation (IM)

distortion (60 Hz:7 kHz=4:1)

0.005% (8 ohms)

Throughrate

125 V/ μ sec, 250 V/ μ sec (Inside)

Residual noise

Less than 115 μ V (network A)

Equalizer deviation

PHONO MM: 20 Hz to 20 kHz,
 ± 0.2 dB

Frequency response

TUNER, CD, AUX, TAPE 1, 2, 3: 2 Hz
to 100 kHz ± 3 dB

S/N

PHONO MC: TA-FA7ES 78dB
(A Fil, 0.5 mV)
TA-FA5ES 76 dB
(A Fil, 0.5 mV)
MM: 87 dB (A Fil, 5 mV)
TUNER, CD, AUX, TAPE1, 2, 3:
105 dB

Inputs

Input sensitivity and impedance

PHONO MC: 0.25 mV, 100 ohms
MM: 2.5 mV, 50 kilohms
TUNER, CD, AUX, TAPE 1, 2, 3:
150 mV, 30 kilohms

Maximum input capability (1 kHz)

PHONO MC: 9 mV
MM: 150 mV

Outputs

Output level / impedance

REC OUT 1, 2, 3: 150 mV, 1 kilohms
PHONES: 10 mW (at 8 ohms)

Tone controls

BASS (100 Hz): ± 7 dB
TREBLE (10 kHz): ± 6 dB

General

Power requirements

220 - 230 V AC, 50/60 Hz

Power consumption

TA-FA7ES: 330 W
TA-FA5ES: 300 W

Dimensions (approx.) (w/h/d)

430 \times 175 \times 450 mm
(17 \times 7 \times 17 $\frac{3}{4}$ inches)

Mass (approx.)

incl. projecting parts and controls
TA-FA7ES: 19.8 kg (43 lb 6 oz)
TA-FA5ES: 17.5 kg (38 lb 10 oz)

Supplied accessories

Remote commander (remote)
RM-S703 (1)
Sony batteries SUM-3(NS) (2)

Design and specifications are subject to change without notice.



INTEGRATED STEREO AMPLIFIER
SONY[®]



TABLE OF CONTENTS

<i>Section</i>	<i>Title</i>	<i>Page</i>
	Specifications	1
1.	GENERAL	
	Location of Controls	3
2.	DISASSEMBLY	4
3.	ELECTRICAL ADJUSTMENT	7
4.	DIAGRAMS	
4-1.	IC Pin Function Description	8
4-2.	Schematic Diagram	11
4-3.	Printed Wiring Boards	
	— MAIN Section —	15
4-4.	Printed Wiring Boards	
	— CONTROL Section —	19
5.	EXPLODED VIEWS	23
6.	ELECTRICAL PARTS LIST	27

SAFETY-RELATED COMPONENT WARNING!!

COMPONENTS IDENTIFIED BY MARK  OR DOTTED LINE WITH MARK  ON THE SCHEMATIC DIAGRAMS AND IN THE PARTS LIST ARE CRITICAL TO SAFE OPERATION. REPLACE THESE COMPONENTS WITH SONY PARTS WHOSE PART NUMBERS APPEAR AS SHOWN IN THIS MANUAL OR IN SUPPLEMENTS PUBLISHED BY SONY.

SECTION 1 GENERAL

This section is extracted from instruction manual.

• Location of Controls Front Panel Descriptions

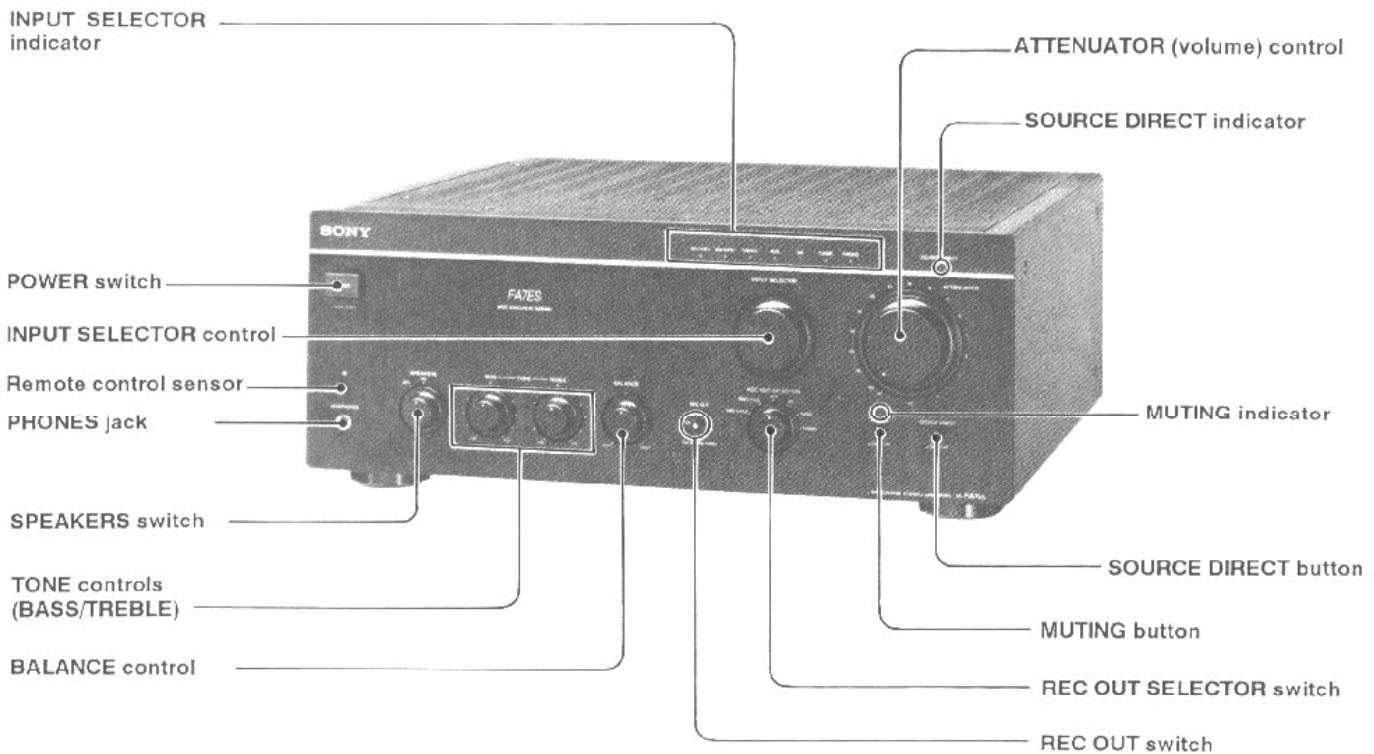

Rear Panel Descriptions

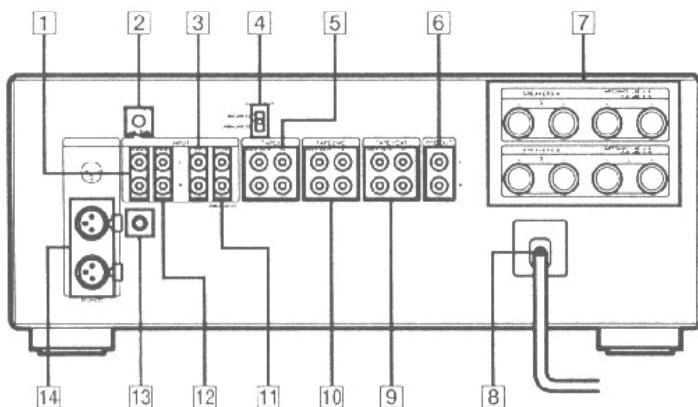

- 1 PHONO
- 2 CARTRIDGE MC/MM
- 3 CD
- 4 AUX INPUT (TA-FA7ES only)
- 5 TAPE3
- 6 PRE OUT
- 7 SPEAKERS A/B
- 8 Mains lead
- 9 TAPE1/DAT
- 10 TAPE2/MD
- 11 AUX(UNBALANCED)
- 12 TUNER
- 13 ϕ (earth)
- 14 AUX(BALANCED) (TA-FA7ES only)

SECTION 2 DISASSEMBLY

Note: Follow the disassembly procedure in the numerical order given.

FRONT PANEL, SIDE PANEL

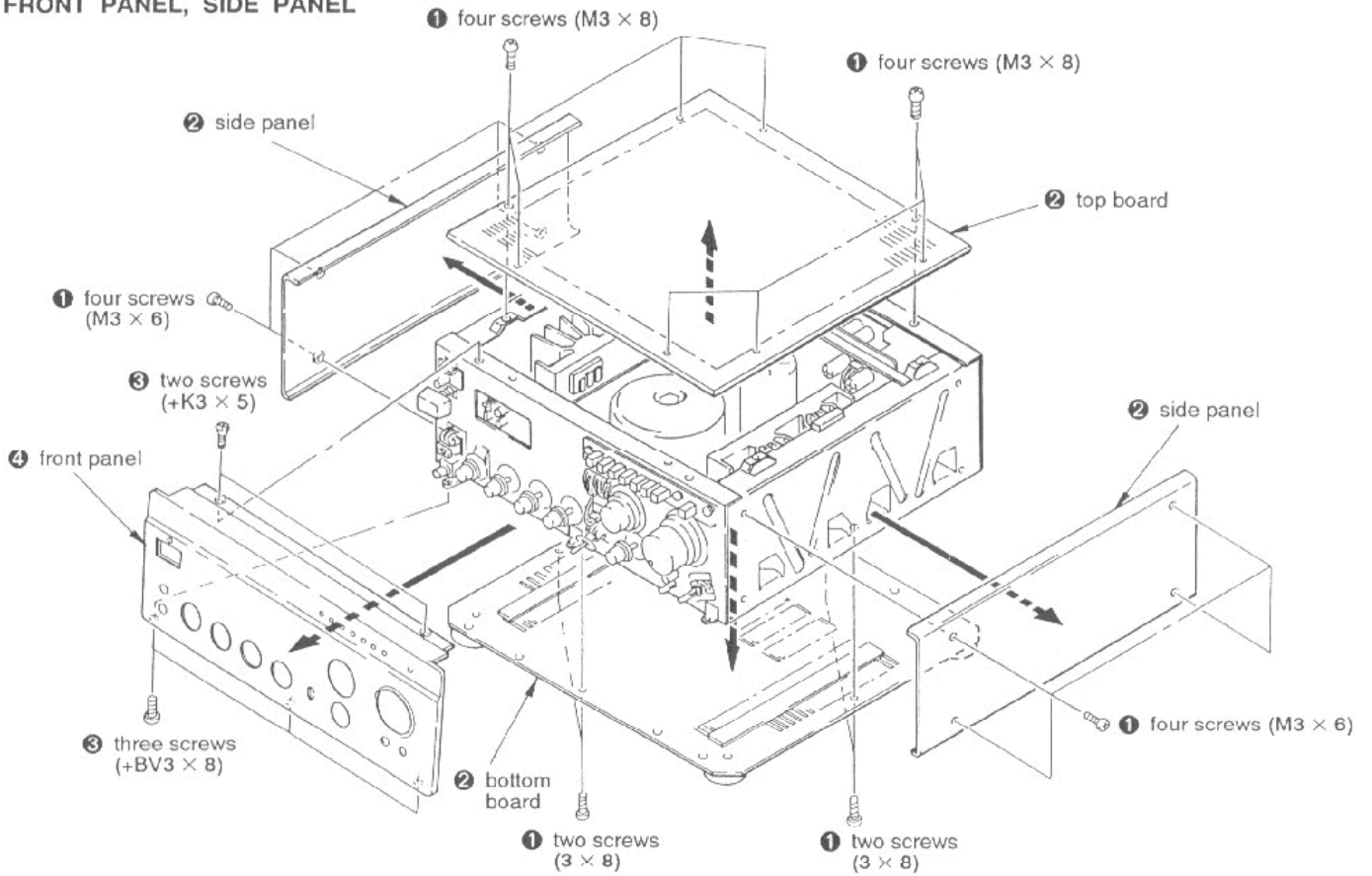

PRO LED, MEDAMA, HP, FUNCTION LED, MUT LED, REC OUT BOARDS

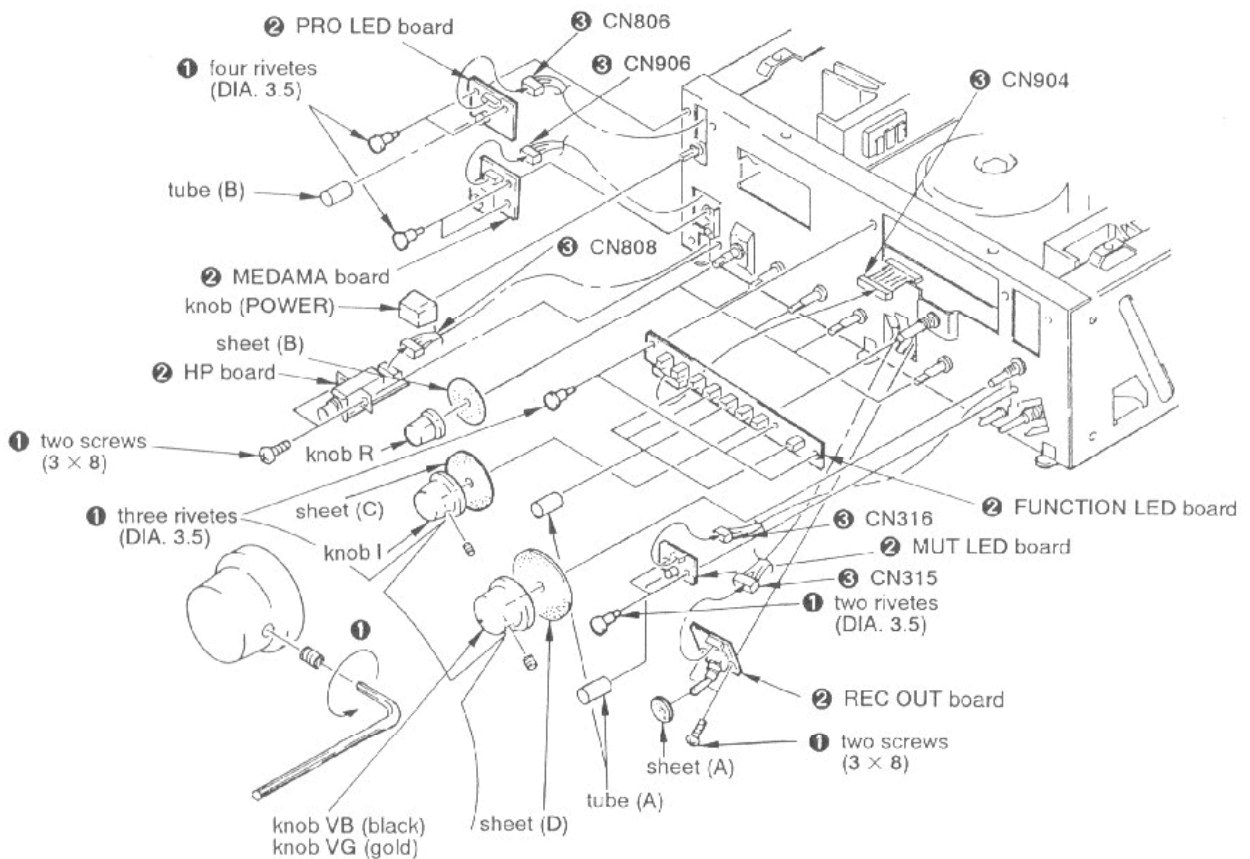

AC SW, TONE CONTROL, VOL BOARDS

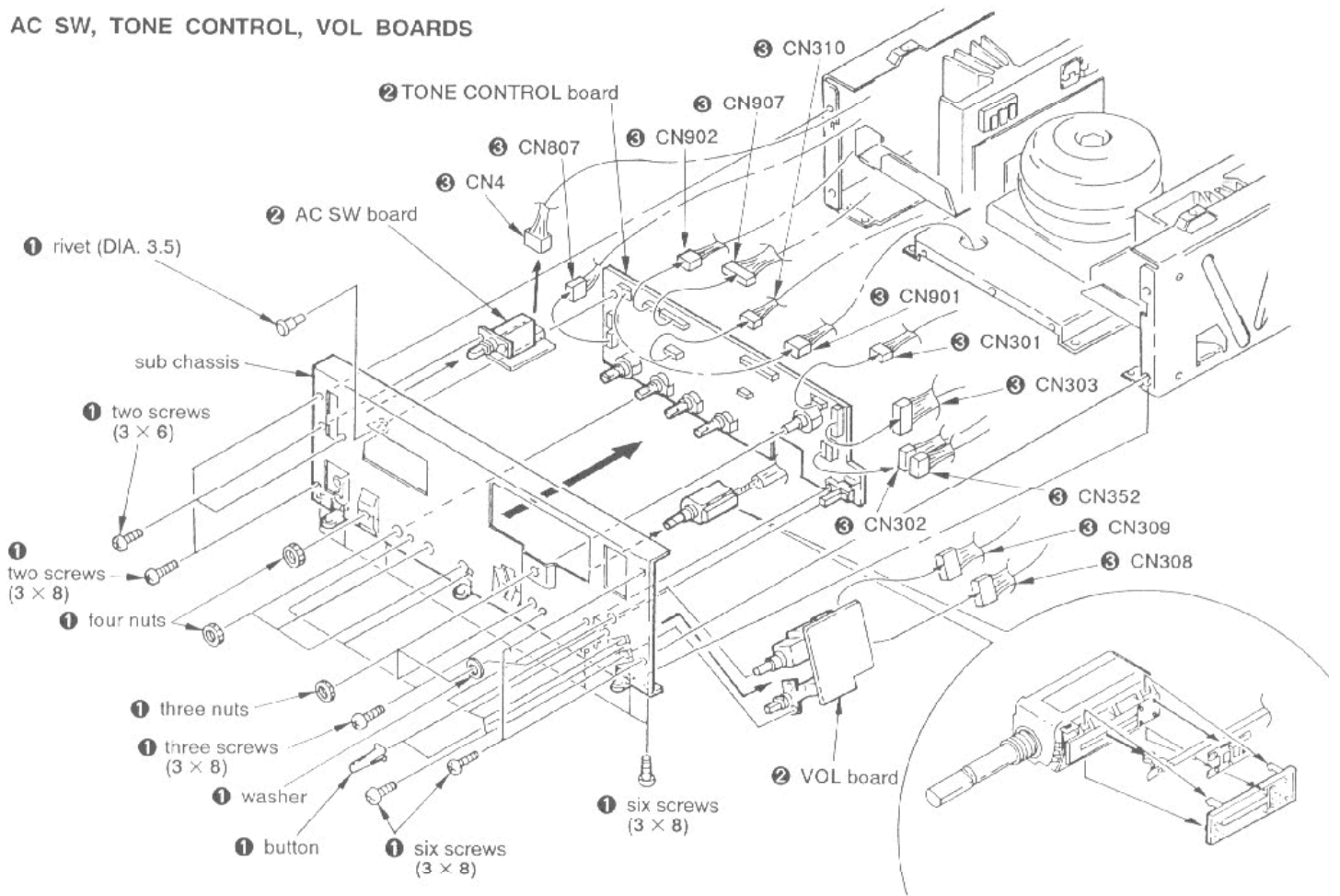

PS, PS JUMPER BOARDS AND POWER TRANSFORMER

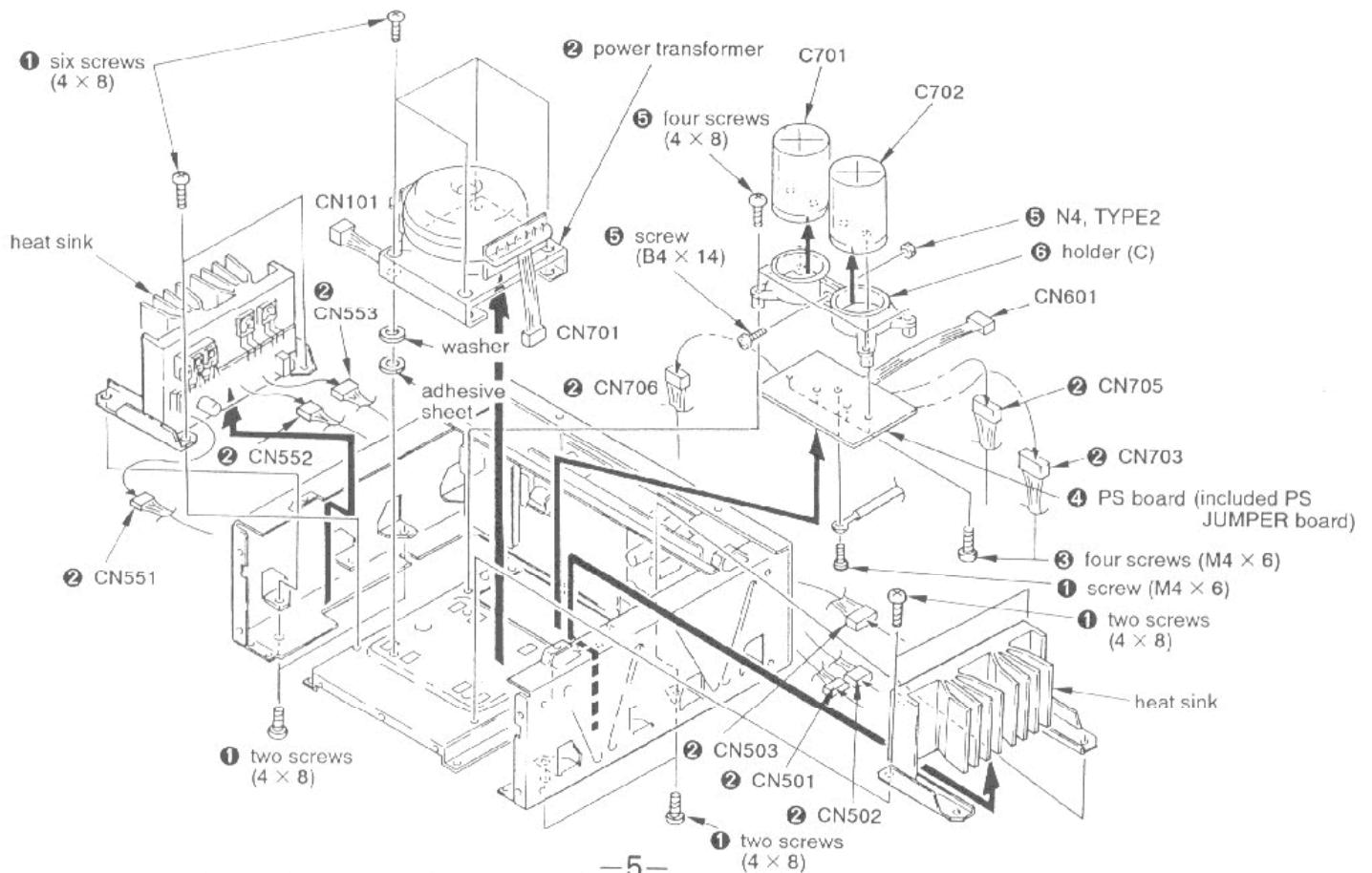

OUT LET, SP-TM, JUMPER, INPUT BOARDS

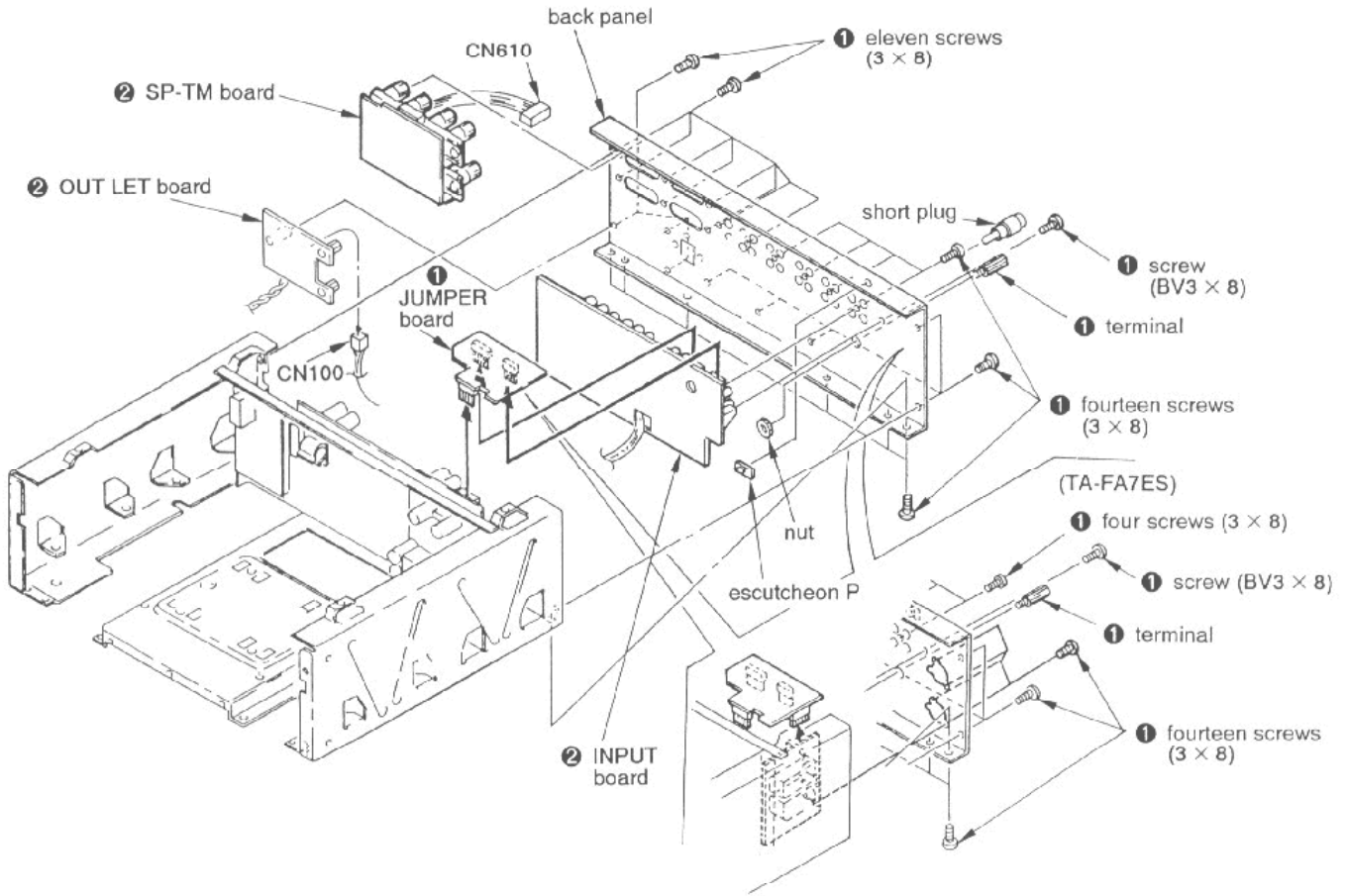

PRO, MAIN. A, PRE PS, BALANCE BOARDS AND HOLDER (P)

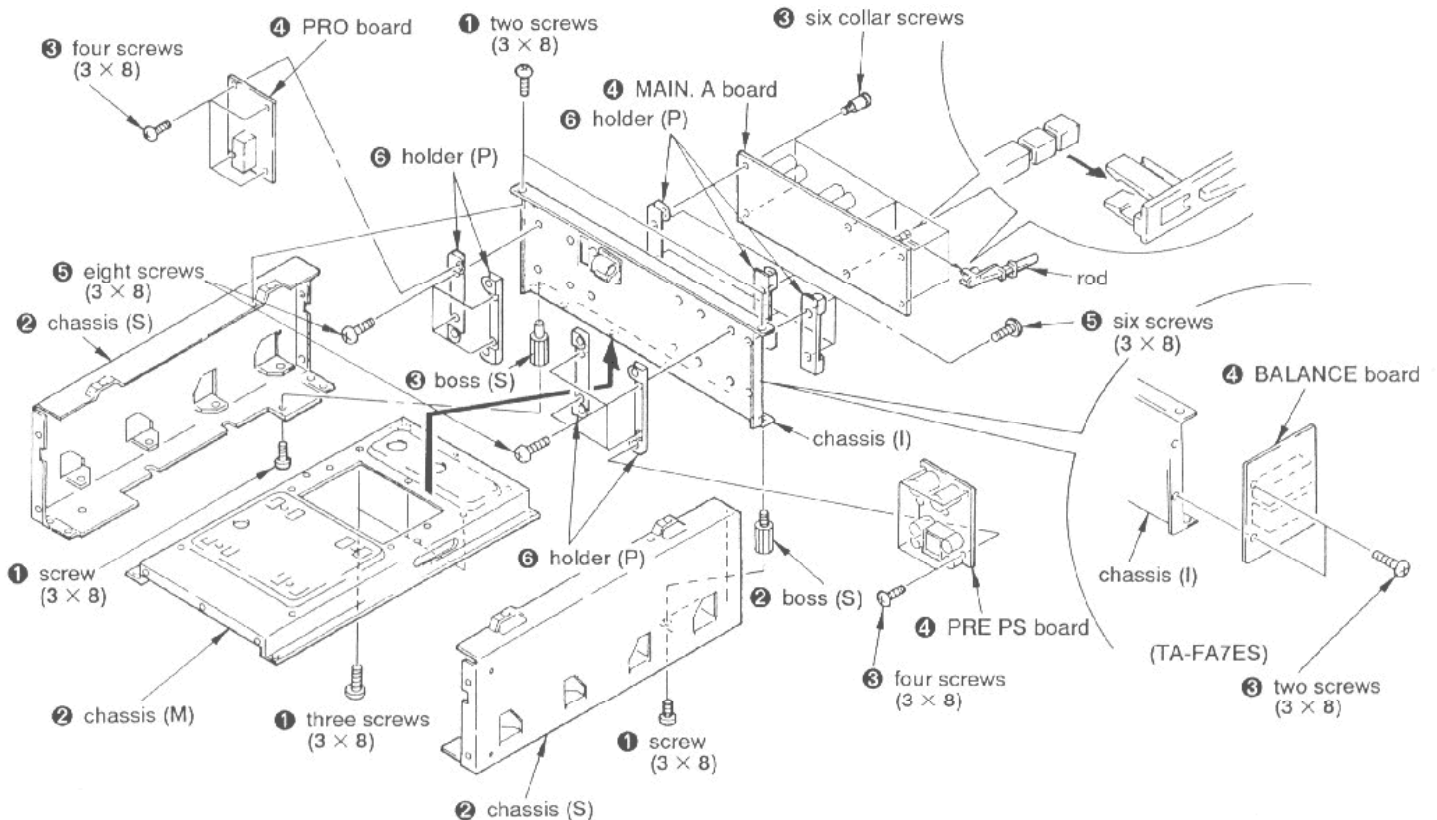

SECTION 3 ELECTRICAL ADJUSTMENT

Note: Adjustment should be performed 5 minutes later, after the power switch is on.

Bias Adjustment

Setting:

ATTENUATOR (Volume) control: minimum
Input signal: No signal input

Procedure:

Adjust RT501 (L-CH) and RT551 (R-CH) for 45 mV reading on the VTVM.

Adjustment Location: MAIN B-L, B-R BOARD

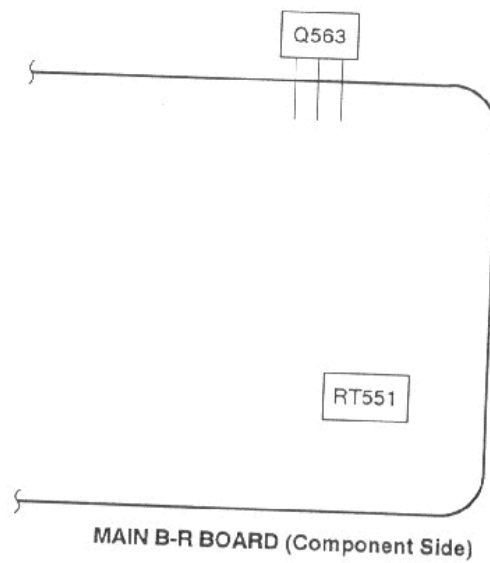
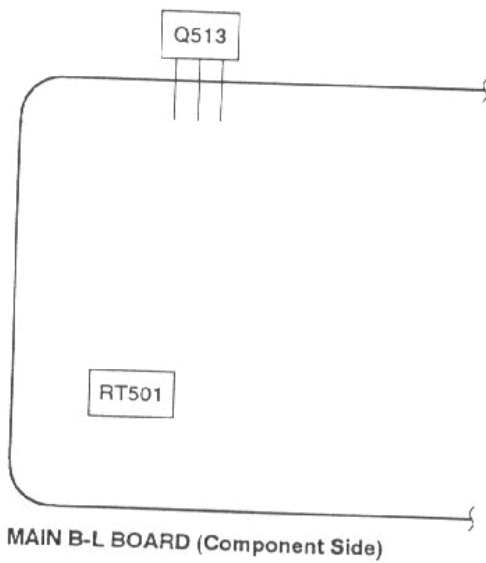
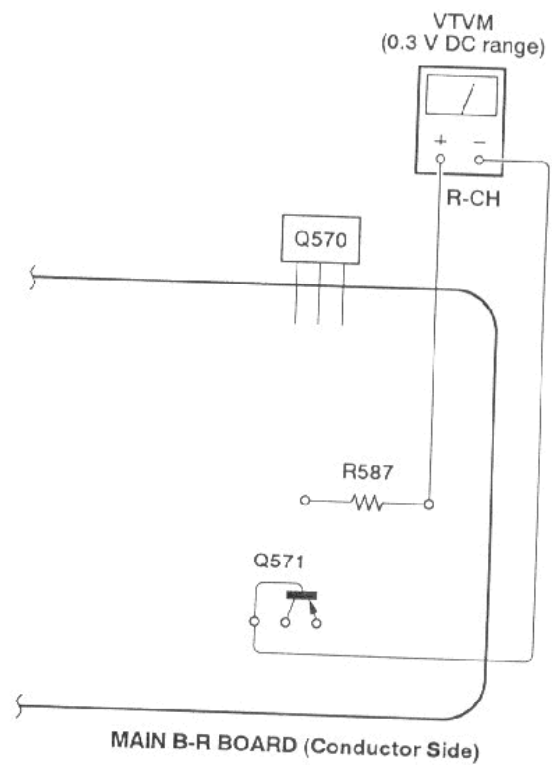
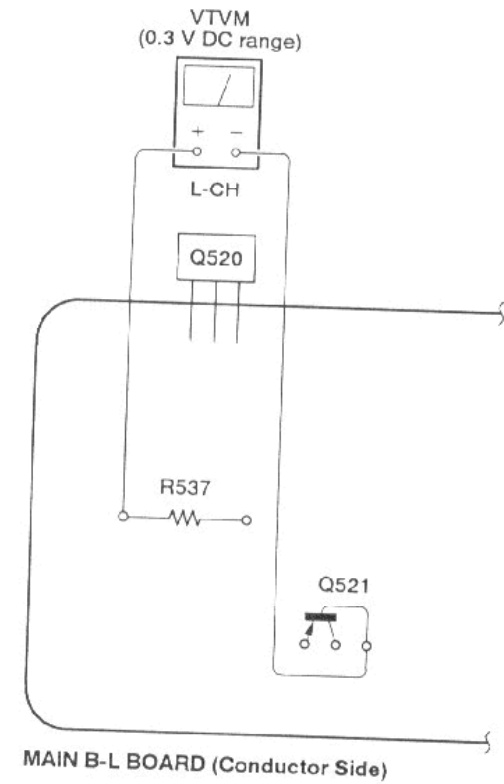

SECTION 4 DIAGRAMS

4-1. IC PIN FUNCTION DESCRIPTION IC901 TMP47C200BN-H327 (SYSTEM CONTROL)

Pin No.	Pin Name	I/O	Function
1	RCL	O	Clock } Data } Serial data of EEPROM (X24C01P)
2	RDT	I/O	
3	VDW	O	Down } Up } VR motor control signal (Active: H, Stop: L-L, Brake: H-H)
4	VUP	O	
5	CD	O	Function relay select signal output (ON: L)
6	MUT	O	Mute control signal output when switching (Mute: H)
7	AUX	O	Function relay select signal output (ON: L)
8	T3	O	Function relay select signal output (ON: L)
9	T2	O	Function relay select signal output (ON: L)
10	T1	O	Function relay select signal output (ON: L)
11	SW0	I	Relativity position detection signal of rotary switch (One of them terminal: H, the other terminal: L) Direction from SW5 to SW0, TUNER → CD → AUX → TAPE2 → TAPE1 → PHONO → TUNER →
12	SW1	I	
13	SW2	I	
14	SW3	I	
15	SW4	I	
16	SW5	I	
17	PHONO	O	Function LED drive signal (ON: L)
18	TUNER	O	
19	CD	O	
20	AUX	O	
21	GND	—	GND terminal
22	TAPE1	O	Function LED drive signal (ON: L)
23	TAPE2	O	
24	TAPE3	O	
25	—	O	Not used (Connected to GND)
26	—	I	Not used (Connected to GND)
27	—	I	Not used (Connected to GND)
28	—	I	Not used (Connected to GND)
29	—	I	Not used (Connected to GND)
30	TEST	—	Test terminal (Open)
31	XIN	—	Oscillation signal 8.19 MHz
32	XOUT	—	
33	RESET	I	Reset signal (Reset: L)
34	HOLD	I	Cancellation of hold mode signal (Start: H)
35	TUNER	O	Function relay select signal output (ON: L)
36	PHONO	O	Function relay select signal output (ON: L)
37	SIRCS	I	SIRCS signal (Active: L)
38	—	O	Not used (Connected to GND)
39	—	O	Not used (Connected to GND)
40	—	O	Not used (Connected to GND)
41	—	O	Model mode switch signal (Connected to GND)
42	VDD	—	POWER supply (+5 V) terminal

• Circuit Boards Location

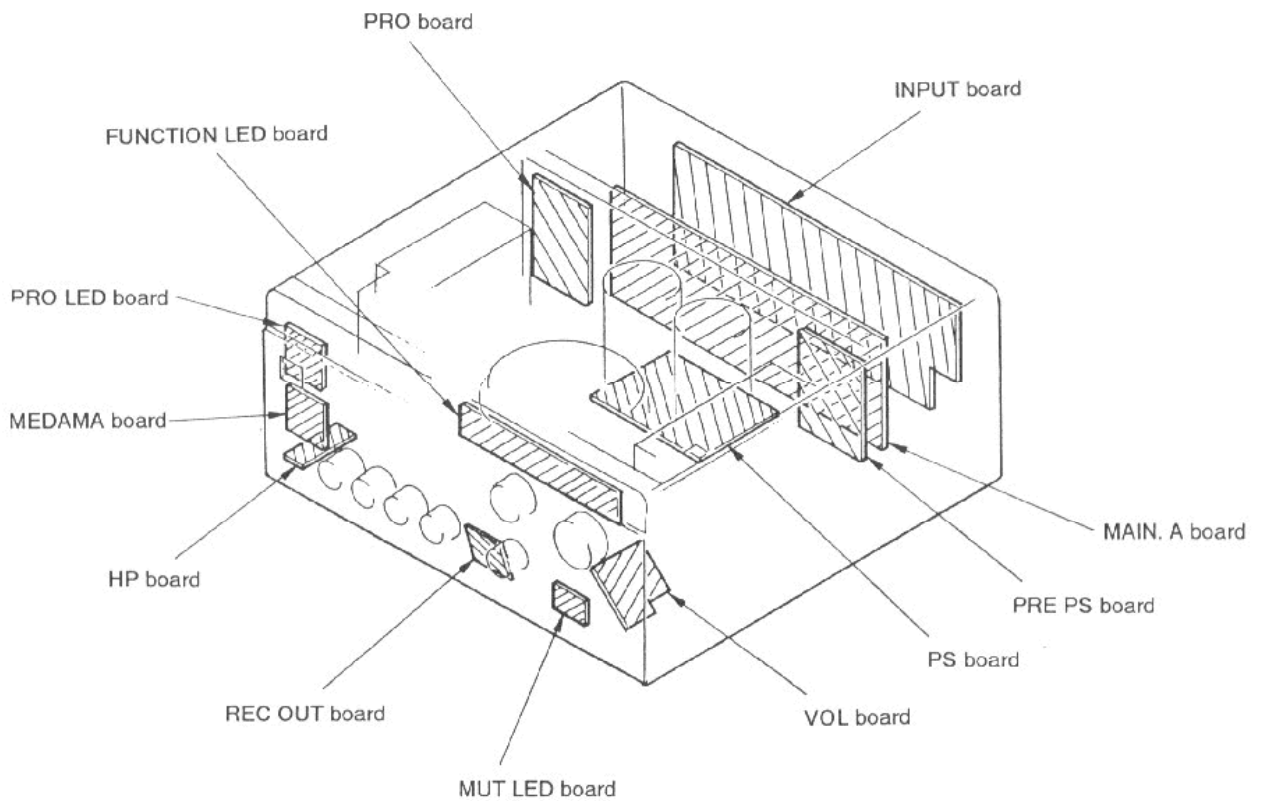
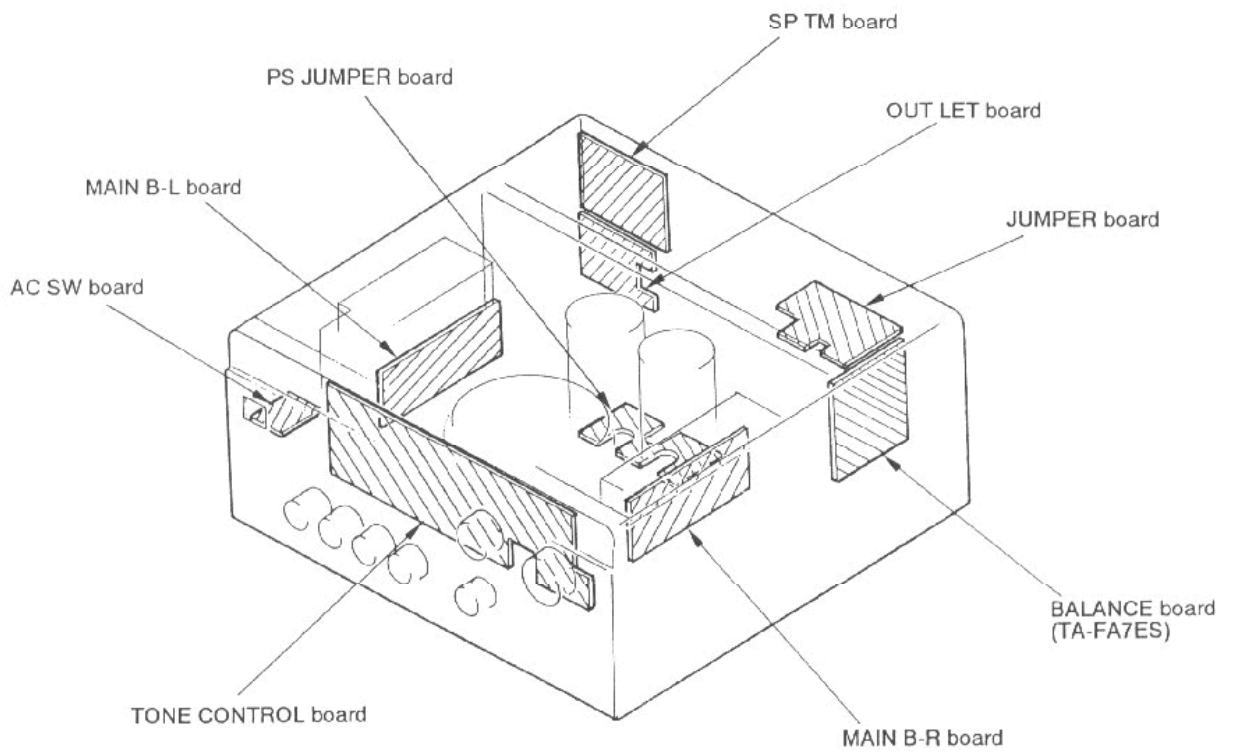

• IC Block Diagrams

PRO board

IC601 μ PC1237HA

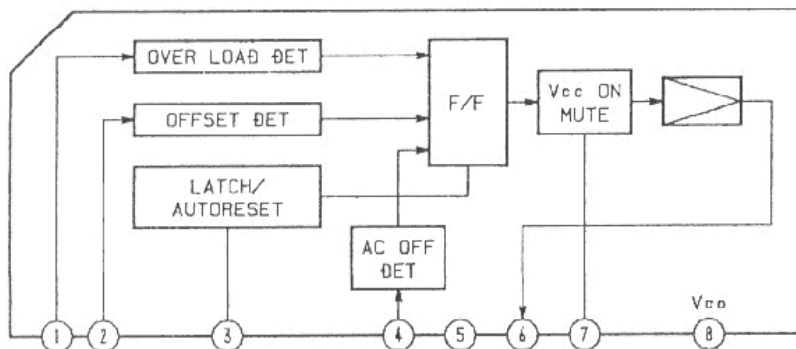

TONE CONTROL board

IC903 X24C01P-S

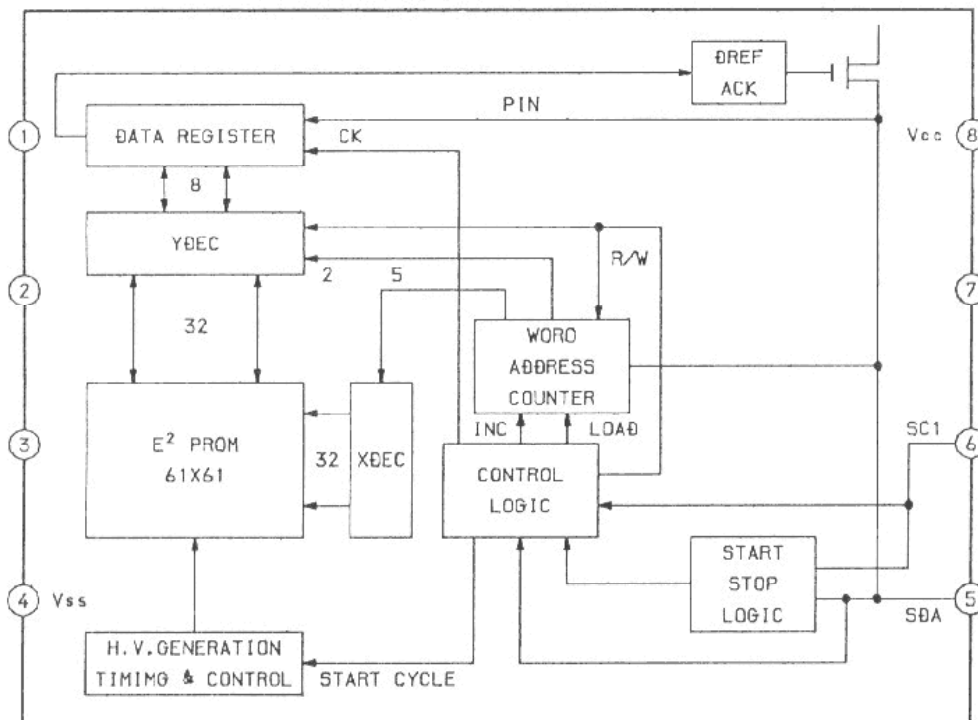

IC904 BA6208

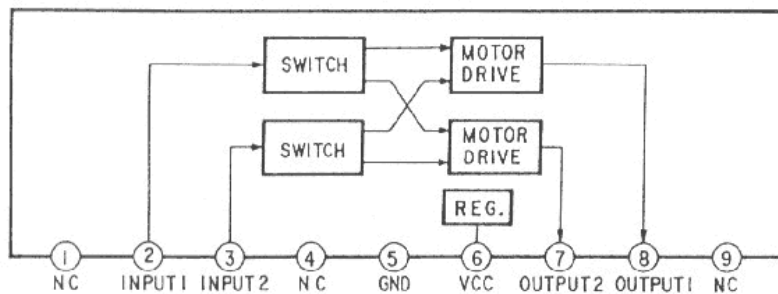

1A-7A9ES/7A/ES

4-2. SCHEMATIC DIAGRAM • See page 10 for IC Block Diagrams.

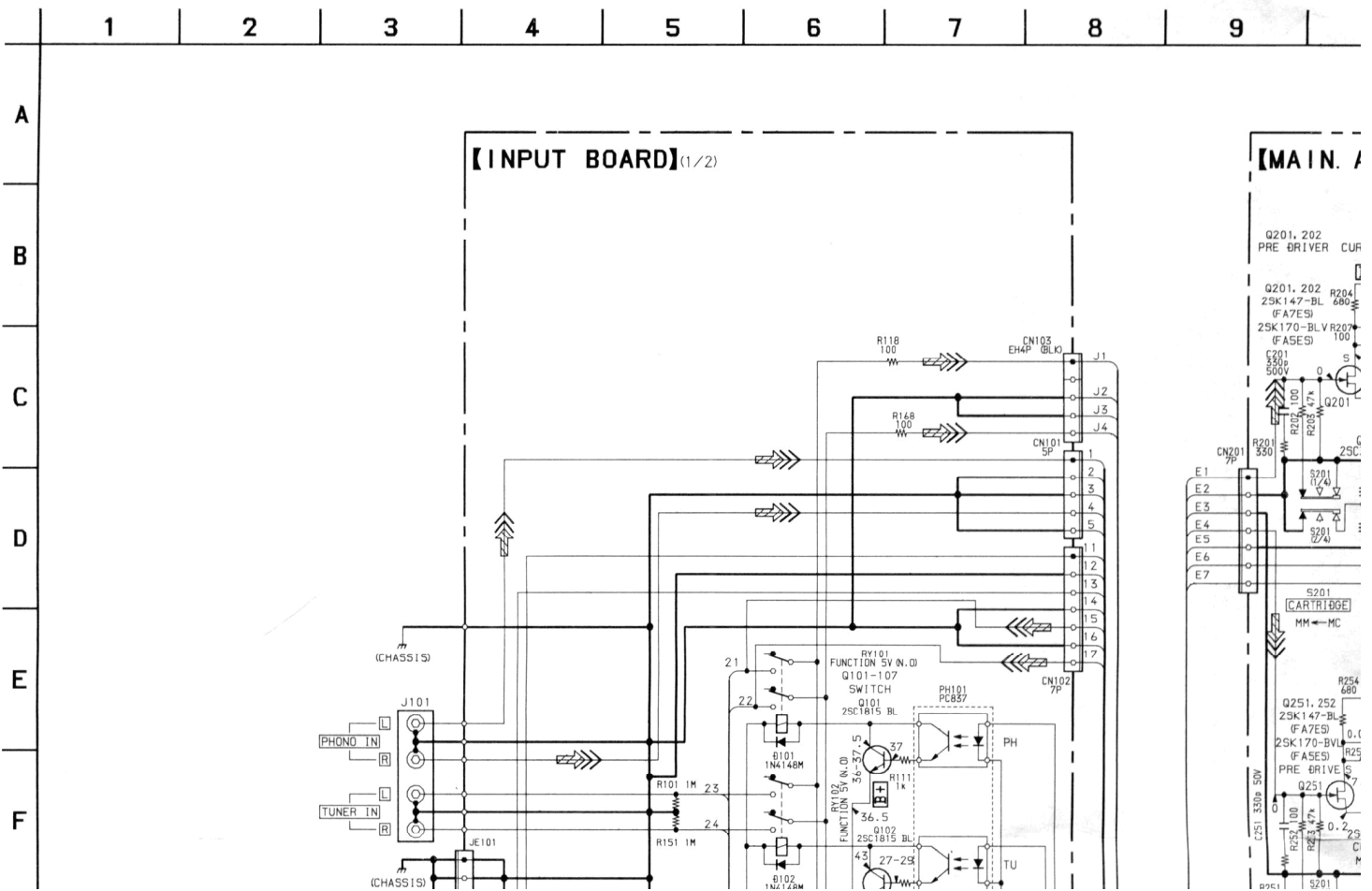

G
H
I
J
K
L
M
N
O
P
Q
R

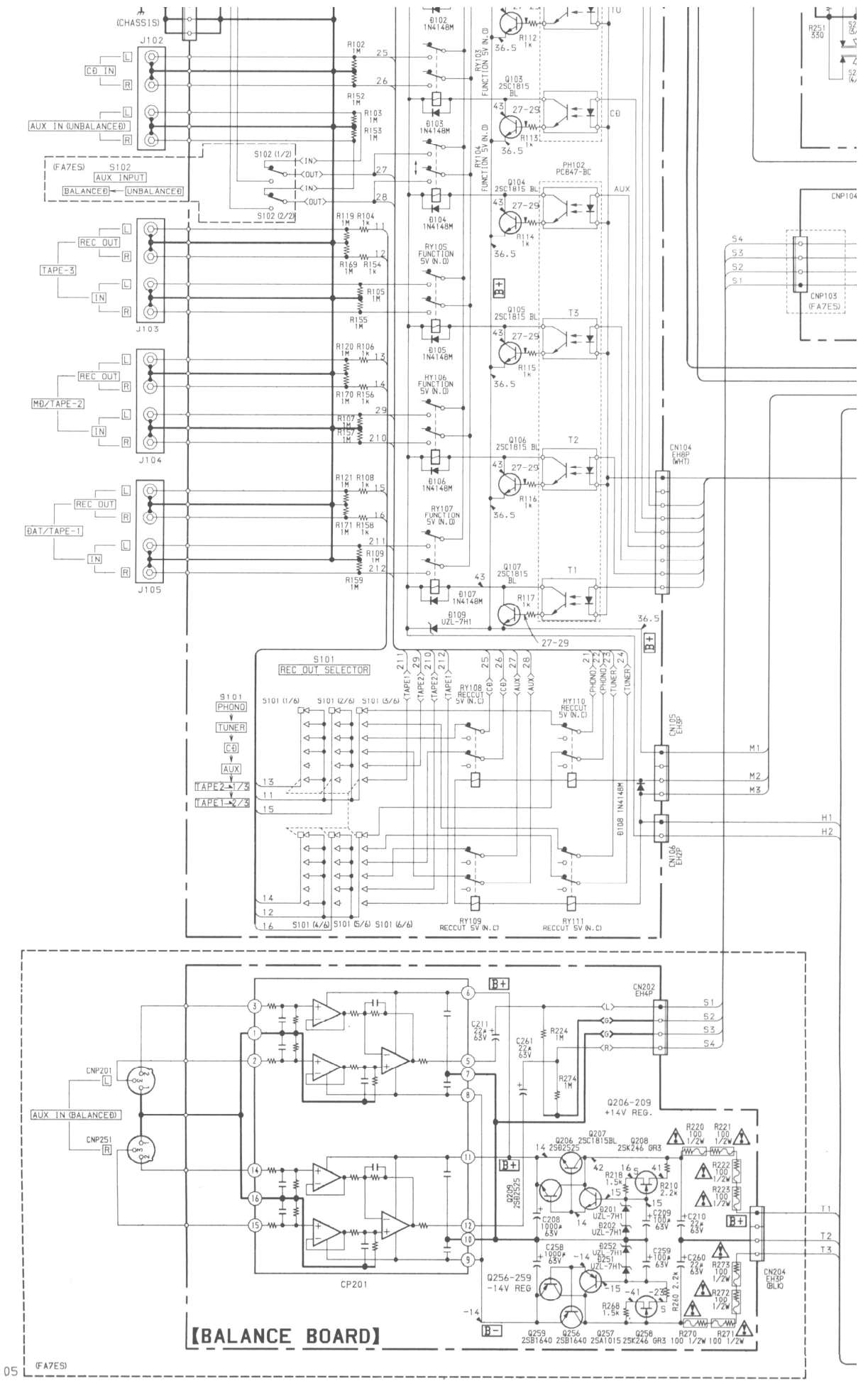

05 (FA7ES)

A BOARD]

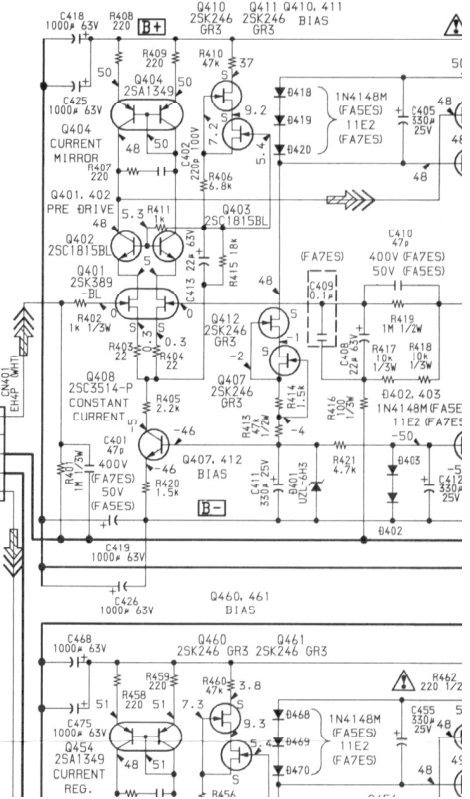
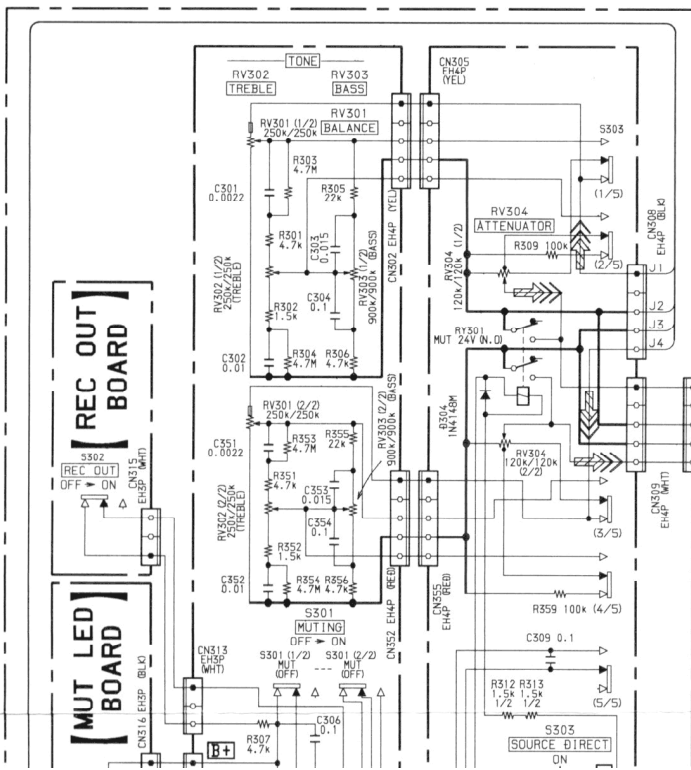
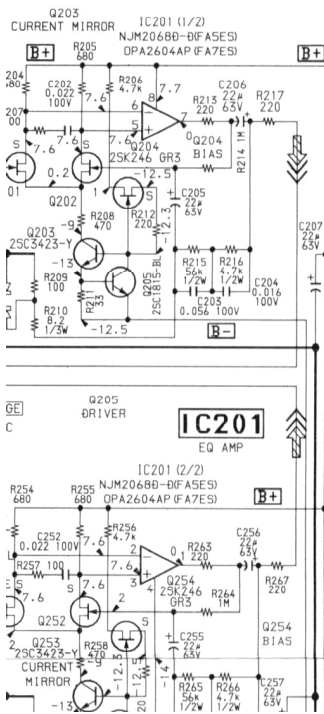

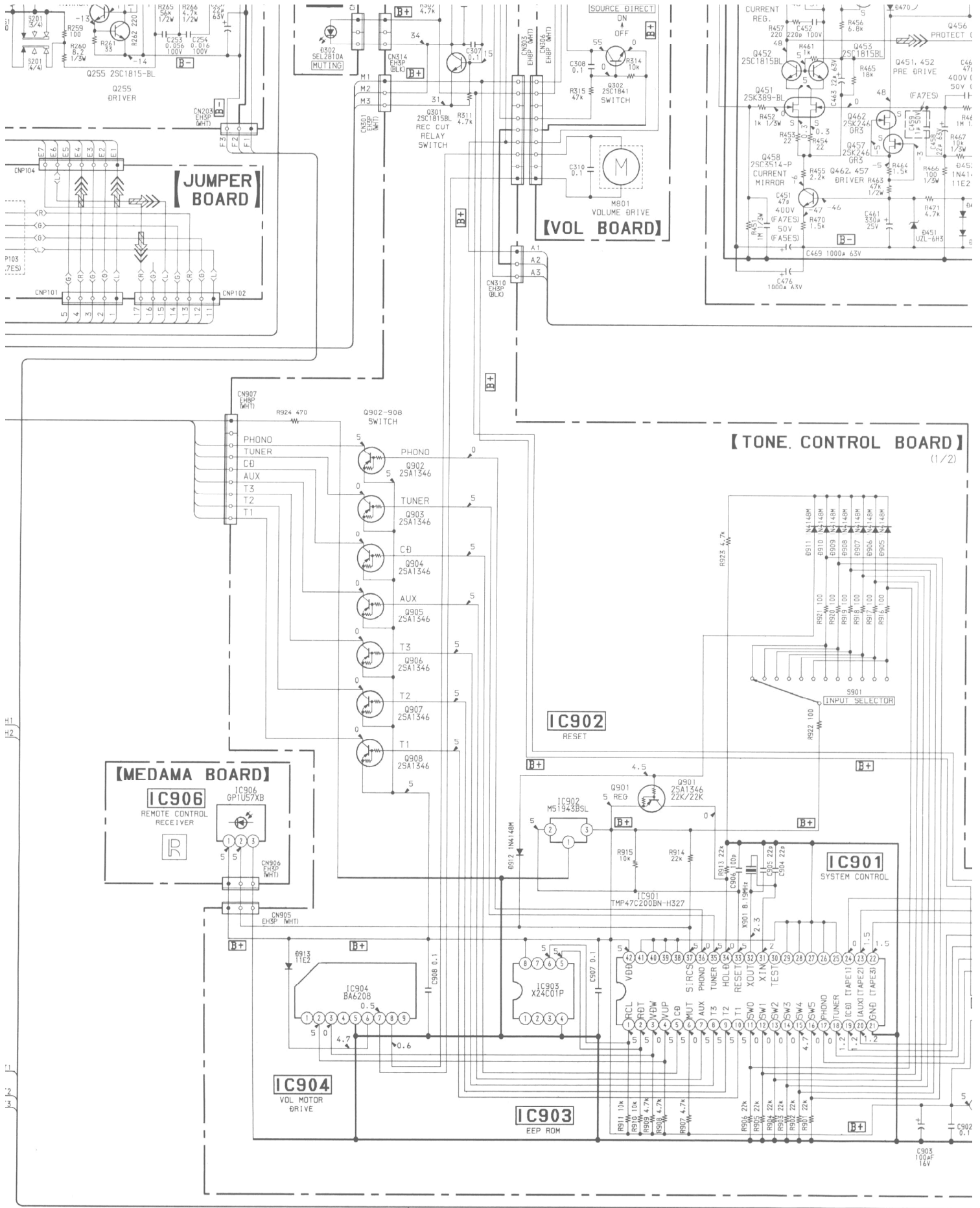

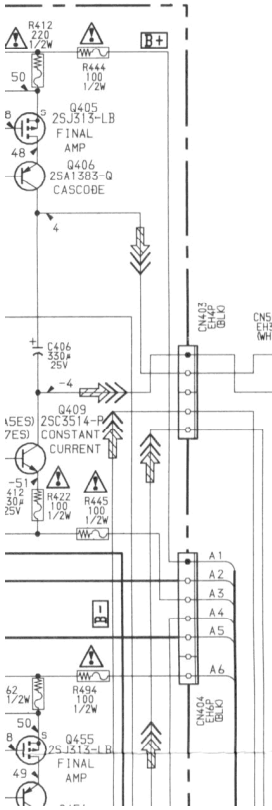
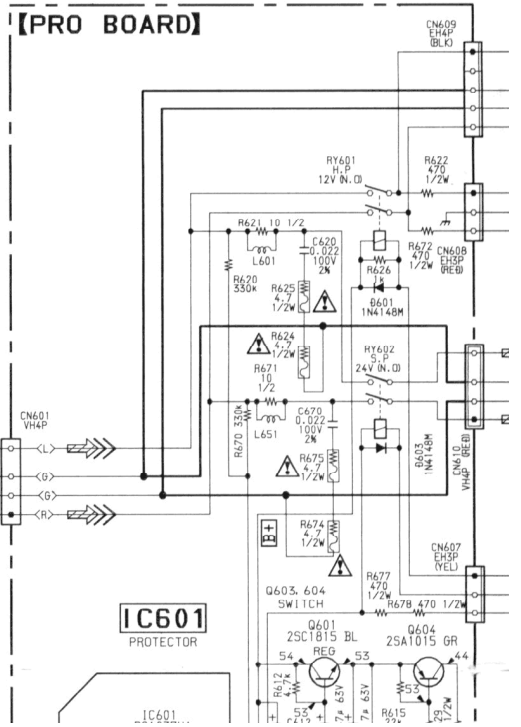
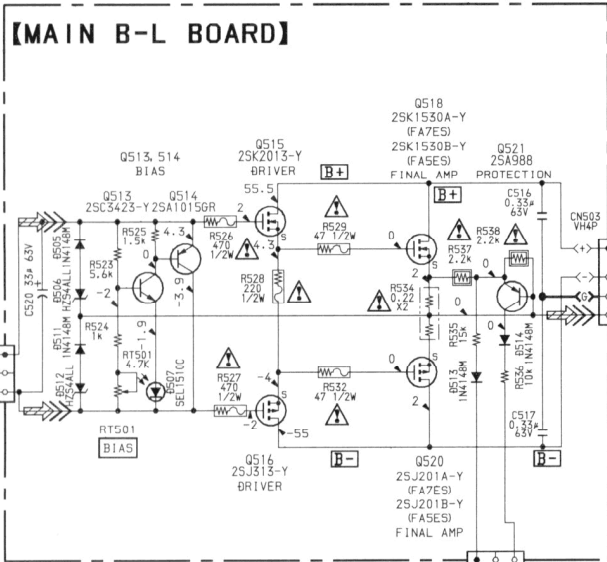

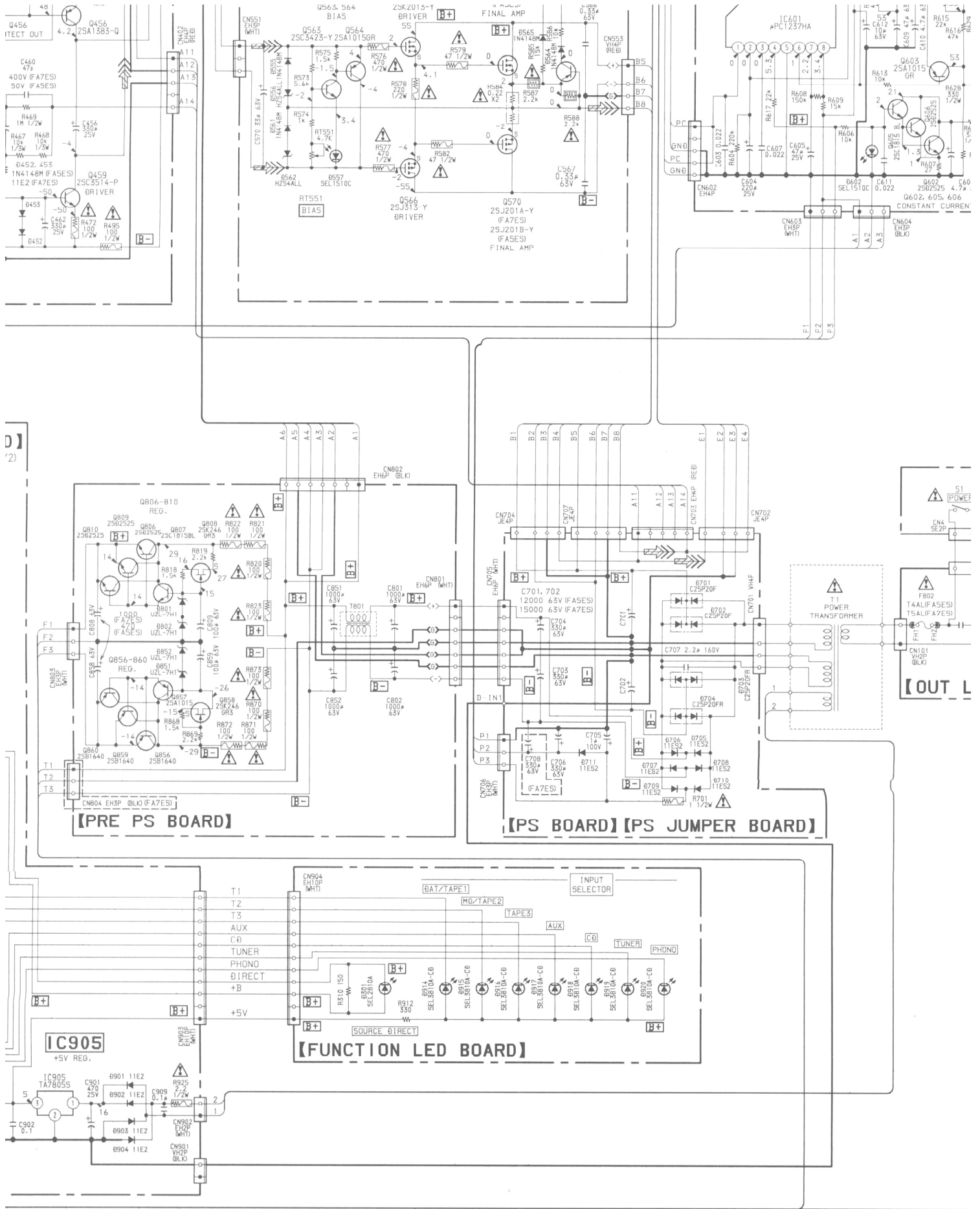

29 | 30 | 31 | 32 | 33

A

B

C

D

E

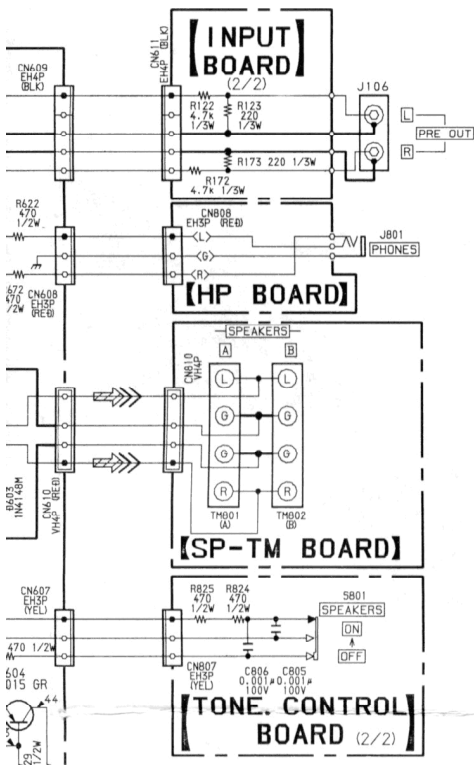

F

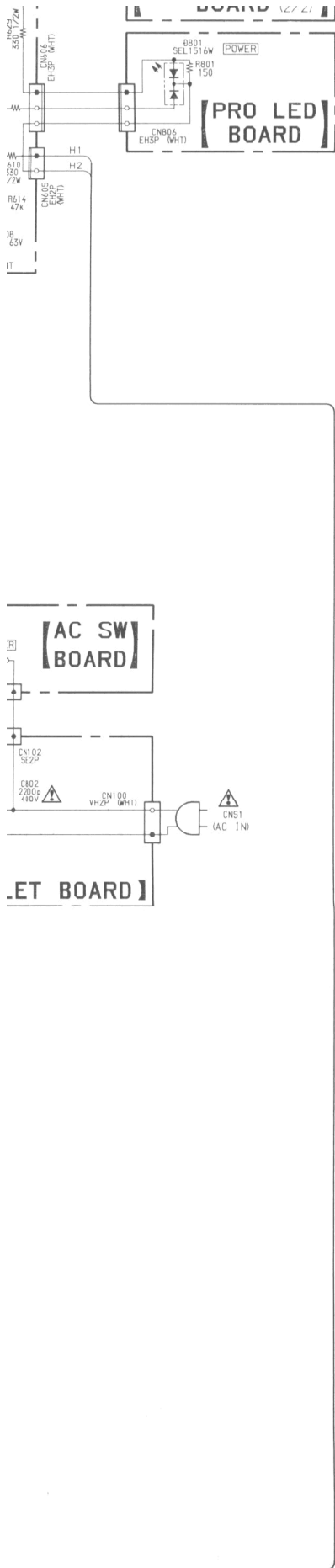









G
H
I
J
K
L
M
N
O
P
Q
R

Note:

- All capacitors are in μF unless otherwise noted. pF : $\mu\mu\text{F}$
50 WV or less are not indicated except for electrolytics and tantalums.
- All resistors are in Ω and $\frac{1}{4}$ W or less unless otherwise specified.
- % : indicates tolerance.
-  : nonflammable resistor.
-  : fusible resistor.

Note: The components identified by mark  or dotted line with mark  are critical for safety. Replace only with part number specified.

-  : B + Line.
-  : B - Line.
-  : panel designation.
-  : adjustment for repair.
- Voltages and waveforms are dc with respect to ground under no-signal (detuned) conditions.
- Voltages are taken with a VOM (10 M Ω /V). Voltage variations may be noted due to normal production tolerances.
- Signal path.
 : PHONO

3. PRINTED WIRING BOARDS - MAIN Section -

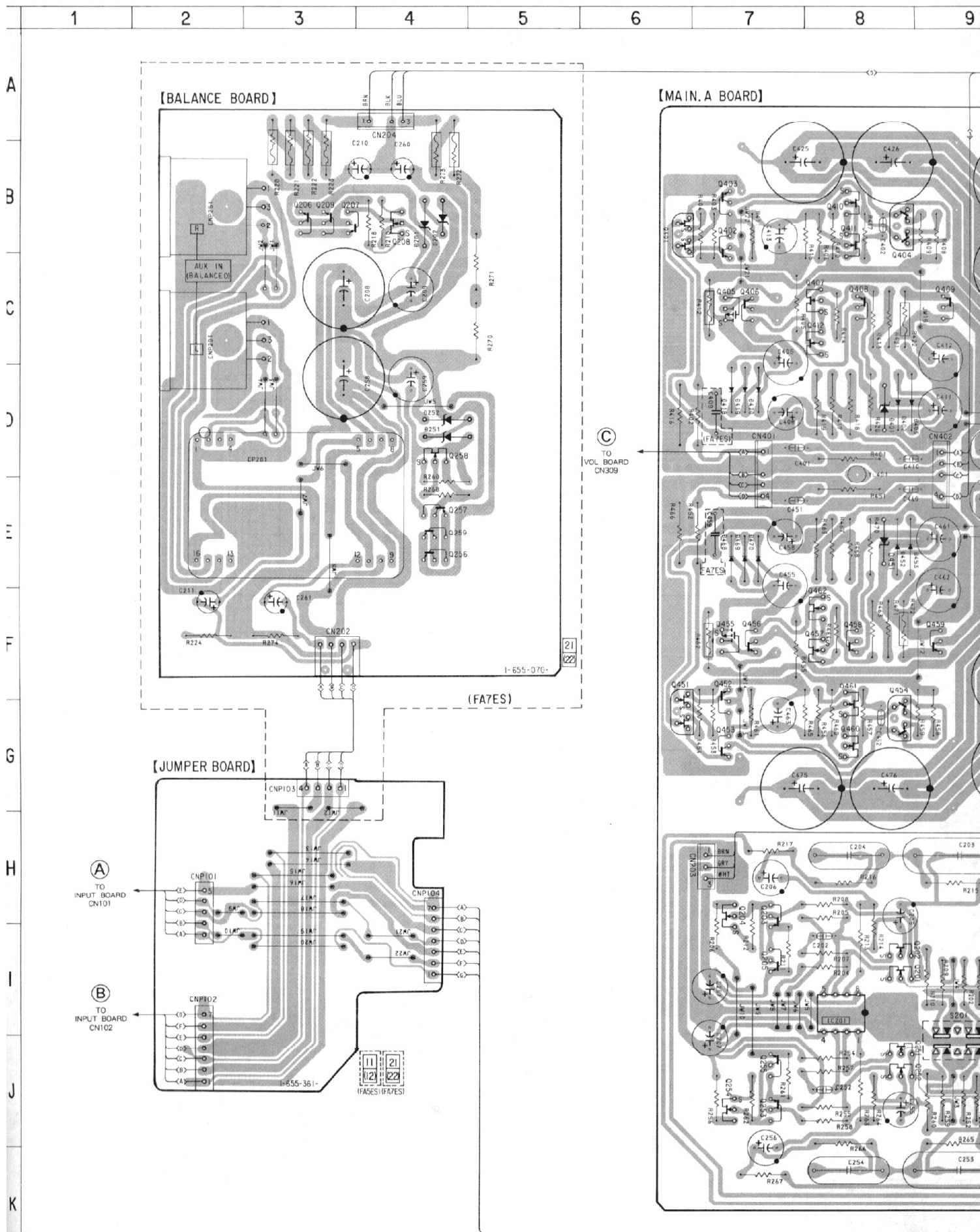

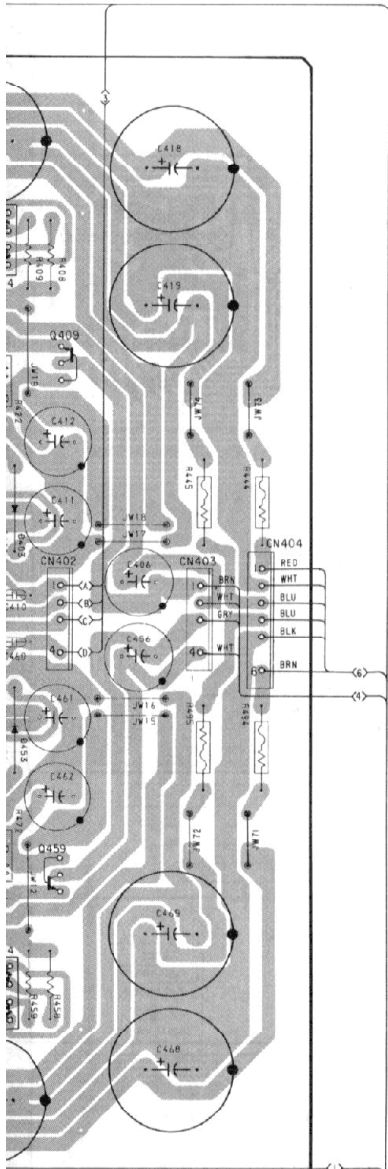

[MAIN B-R BOARD]

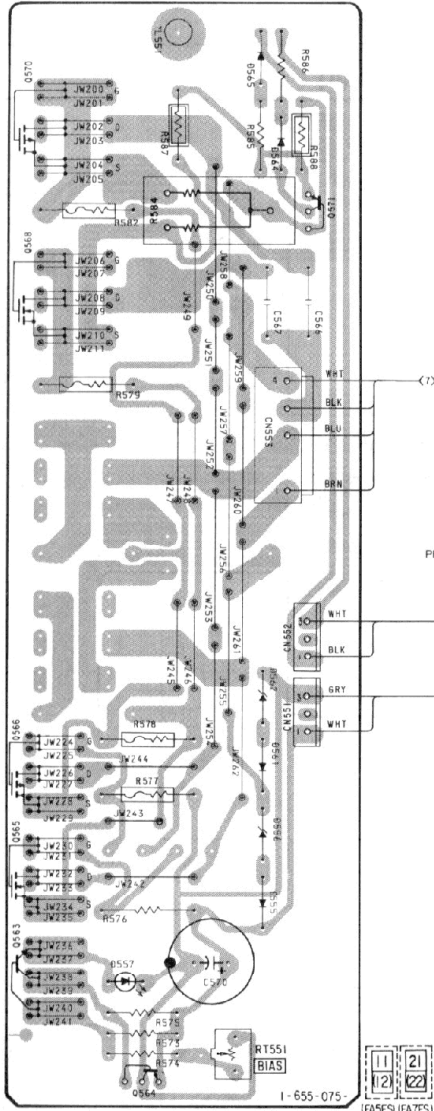

[MAIN B-L BOARD]

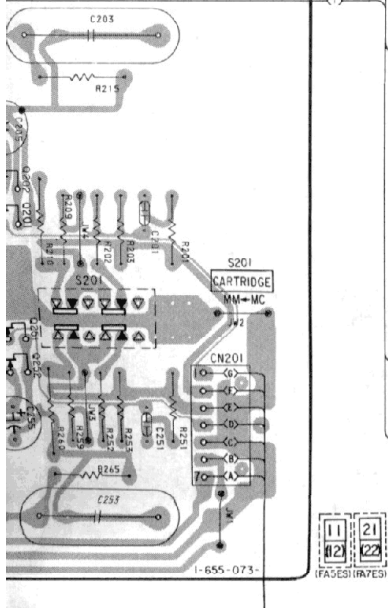
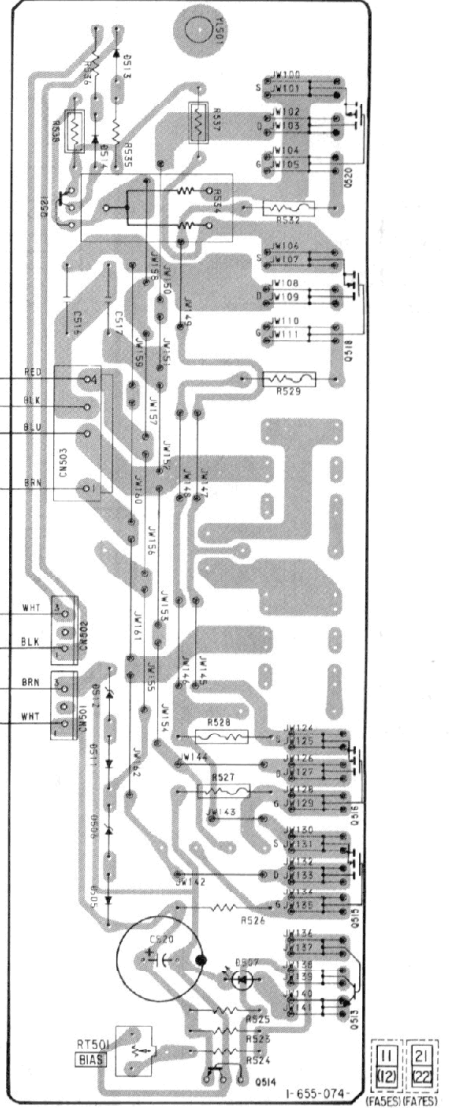

[PRE PS BOARD]

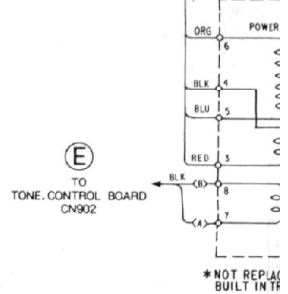
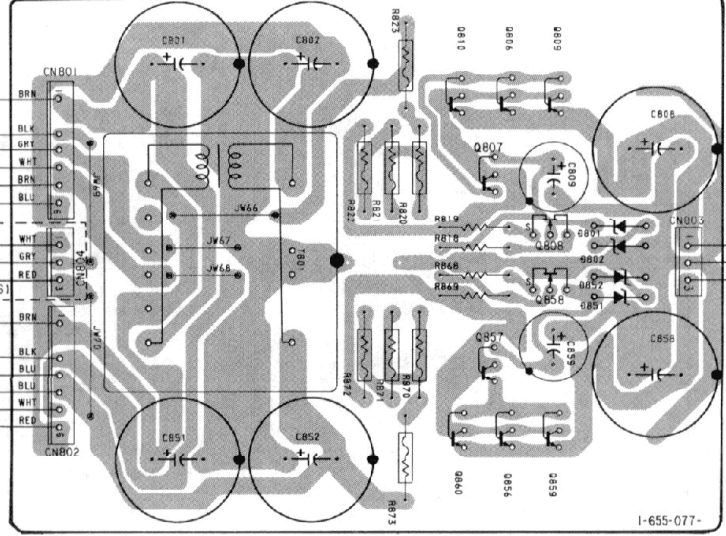

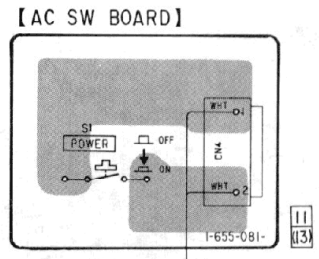
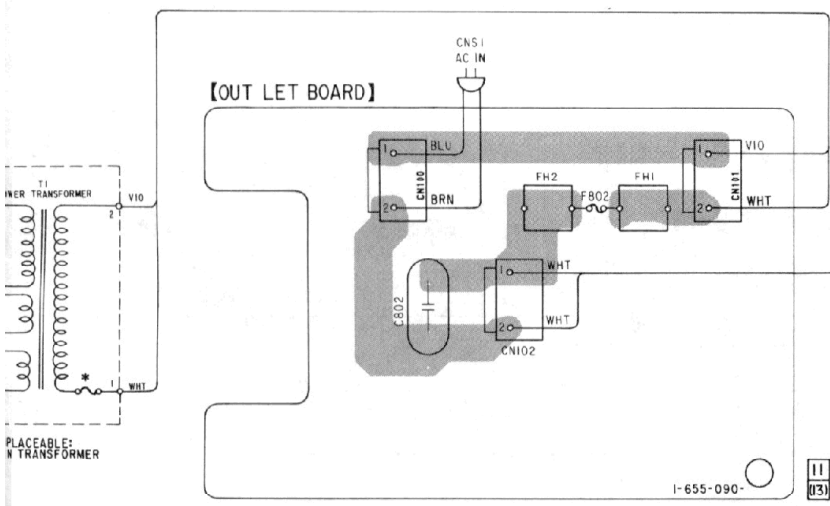
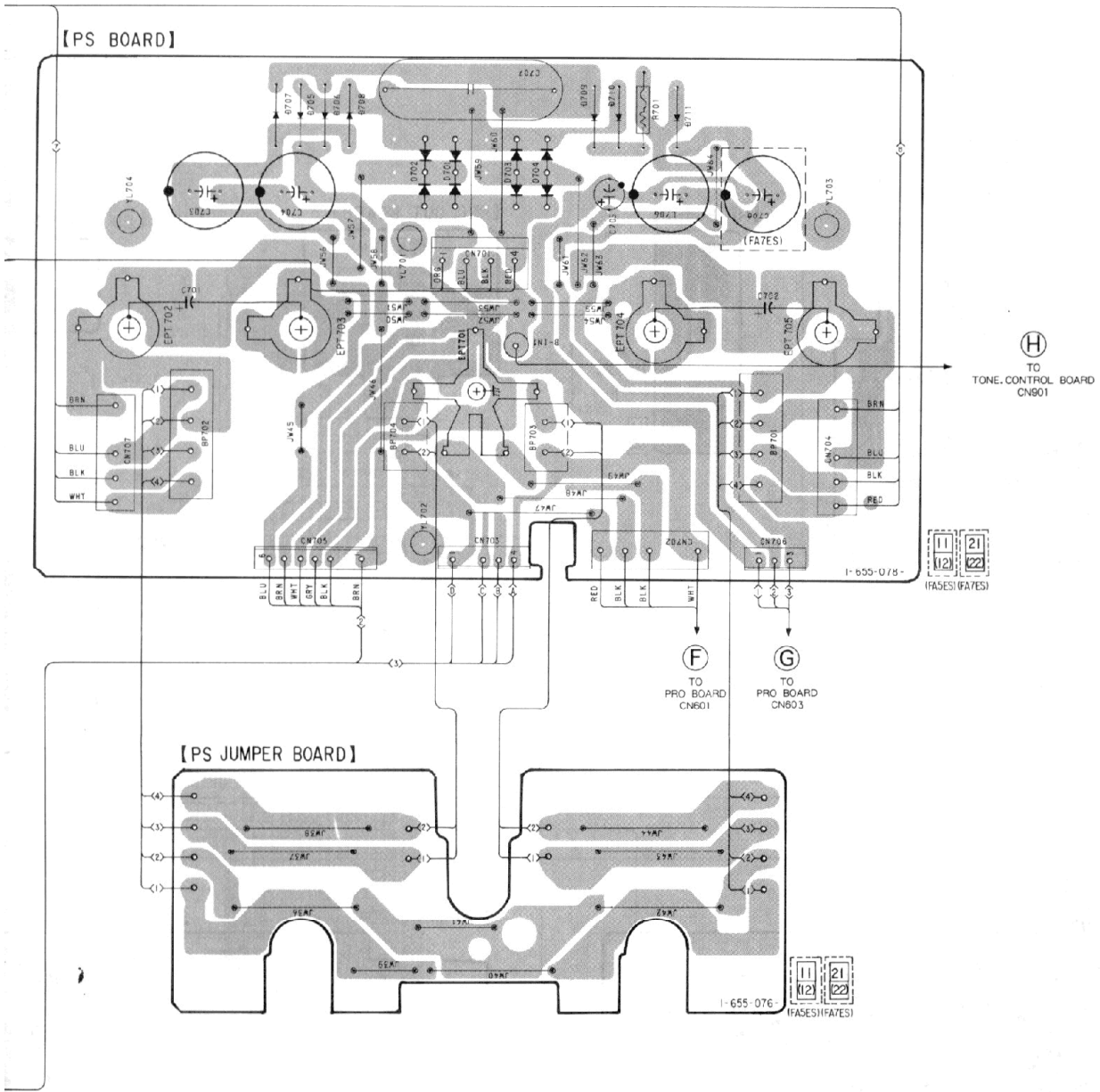

● Semiconductor Location

Ref. No.	Location	Ref. No.	Location
○D201	B-4	Q251	J-8
○D202	B-4	Q252	J-8
○D251	D-4	Q253	J-7
○D252	D-4	Q254	J-7
D401	D-8	Q255	J-7
D402	D-8	○Q256	E-4
D403	D-8	○Q257	E-4
D418	D-7	○Q258	D-4
D419	D-7	○Q259	E-4
D420	D-7	Q401	B-6
D451	E-8	Q402	B-7
D452	E-8	Q403	B-7
D453	E-8	Q404	B-8
D468	E-7	Q405	C-7
D469	E-7	Q406	C-7
D470	E-7	Q407	C-8
D505	F-15	Q408	C-8
D506	F-15	Q409	C-9
D507	G-16	Q410	B-8
D511	F-15	Q411	B-8
D512	E-15	Q412	C-8
D513	B-15	Q451	G-6
D514	B-15	Q452	G-7
D555	G-13	Q453	G-7
D556	F-13	Q454	G-8
D557	G-12	Q455	F-7
D561	F-13	Q456	F-7
D562	E-13	Q457	F-8
D564	B-13	Q458	F-8
D565	B-13	Q459	F-9
D701	B-20	Q460	G-8
D702	B-20	Q461	G-8
D703	B-20	Q462	F-8
D704	B-21	Q513	G-16
D705	B-19	Q514	H-16
D706	B-19	Q515	G-16
D707	B-19	Q516	F-16
D708	B-19	Q518	C-16
D709	B-21	Q520	B-16
D710	B-21	Q521	C-15
D711	B-21	Q563	G-11
D801	J-15	Q564	H-12
D802	J-15	Q565	F-11
D851	J-15	Q566	F-11
D852	J-15	Q568	C-11
IC201	J-8	Q570	B-11
Q201	I-8	Q571	B-13
Q202	I-8	Q806	I-14
Q203	I-7	Q807	I-14
Q204	I-7	Q808	J-14
Q205	I-7	Q809	I-14
○Q206	B-3	Q810	I-14
○Q207	B-3	Q856	K-14
○Q208	B-4	Q857	K-14
○Q209	B-3	Q858	J-14
		Q859	K-14
		Q860	K-14

Note:

○:FA7ES ONLY

Note:

- ○ : parts extracted from the component side.
- ■ : Pattern from the side which enables seeing.

• Semiconductor Location

Ref. No.	Location
D101	G-19
D102	G-19
D103	G-18
D104	H-17
D105	H-16
D106	H-15
D107	H-14
D108	J-18
D109	H-13
D301	H-25
D302	C-10
D304	C-2
D601	I-3
D602	I-6
D603	H-4
D801	E-7
D901	B-22
D902	B-22
D903	B-22
D904	B-22
D905	C-16
D906	C-16
D907	C-17
D908	C-17
D909	C-17
D910	C-17
D911	B-16
D912	B-16
D913	C-20
D914	C-25
D915	C-25
D916	D-25
D917	D-25
D918	E-25
D919	F-25
D920	F-25
PH101	G-13
PH102	G-14
IC601	I-5
IC901	B-18
IC902	B-20
IC903	C-19
IC904	C-21
IC905	B-23
IC906	E-10
Q101	G-13
Q102	G-13
Q103	H-13
Q104	G-17
Q105	G-16
Q106	G-15
Q107	G-14
Q301	B-14
Q302	B-2
Q601	H-4
Q602	H-6
Q603	H-4
Q604	H-5
Q605	H-6
Q606	H-6
Q901	B-16
Q902	B-21
Q903	B-21
Q904	B-21
Q905	B-21
Q906	B-21
Q907	B-22
Q908	B-22

Note:

- : parts extracted from the component side.
- ▨ : Pattern from the side which enables seeing.

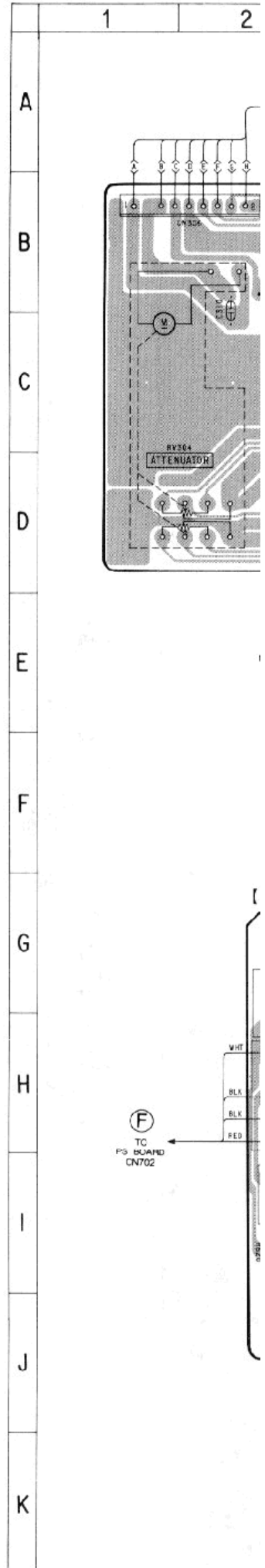

I. PRINTED WIRING BOARDS – CONTROL Section –

1 2 3 4 5 6 7 8 9

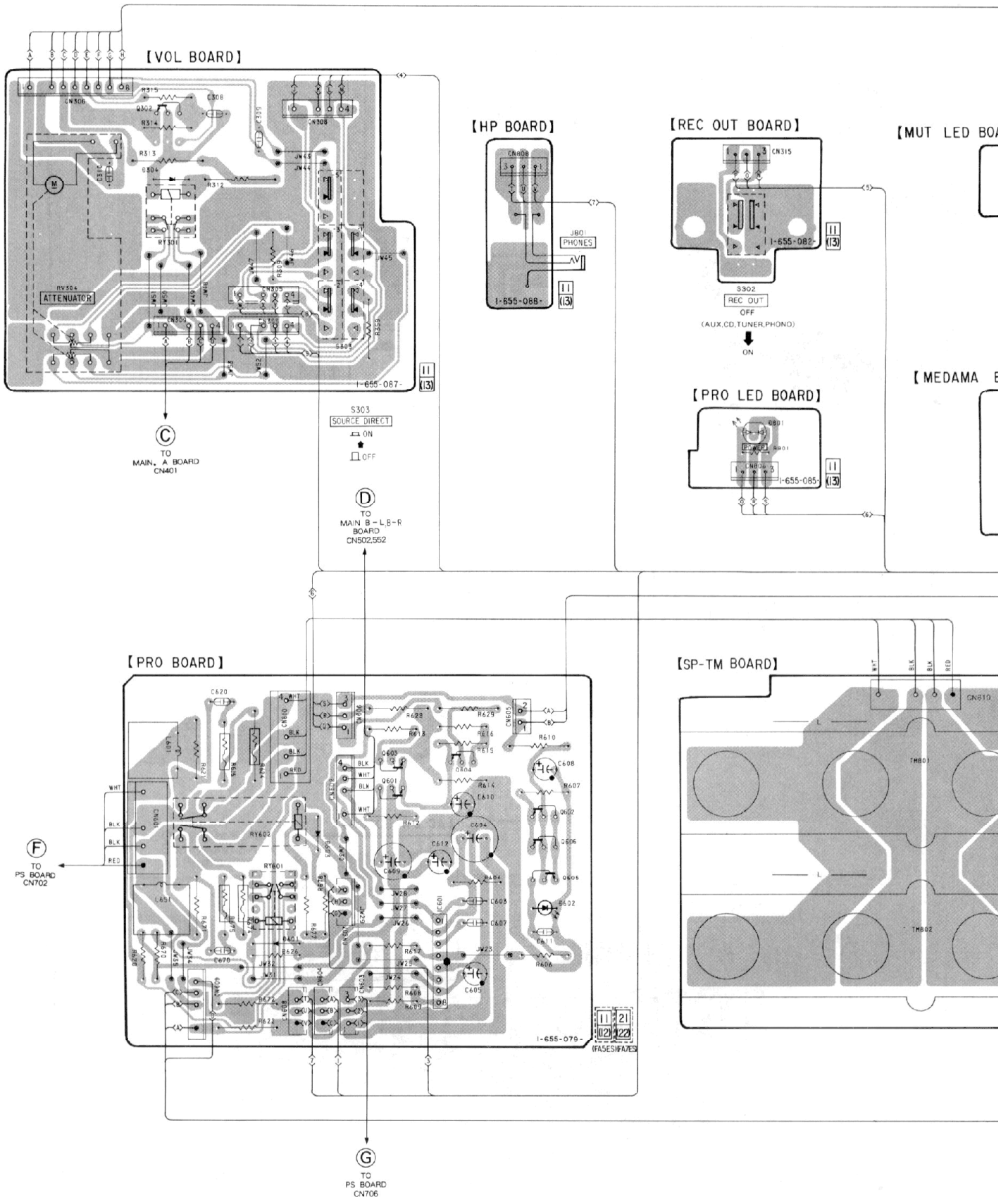

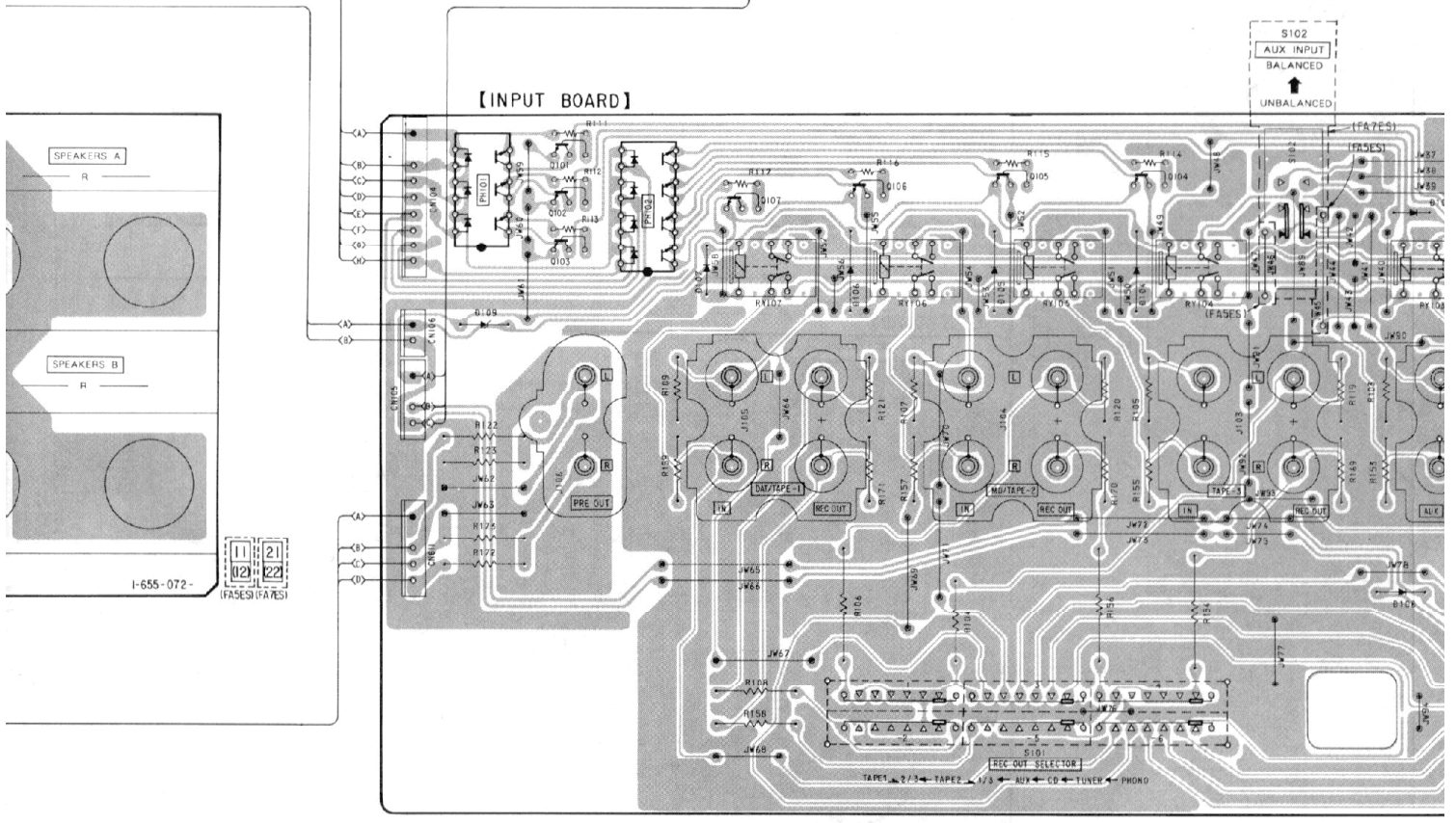
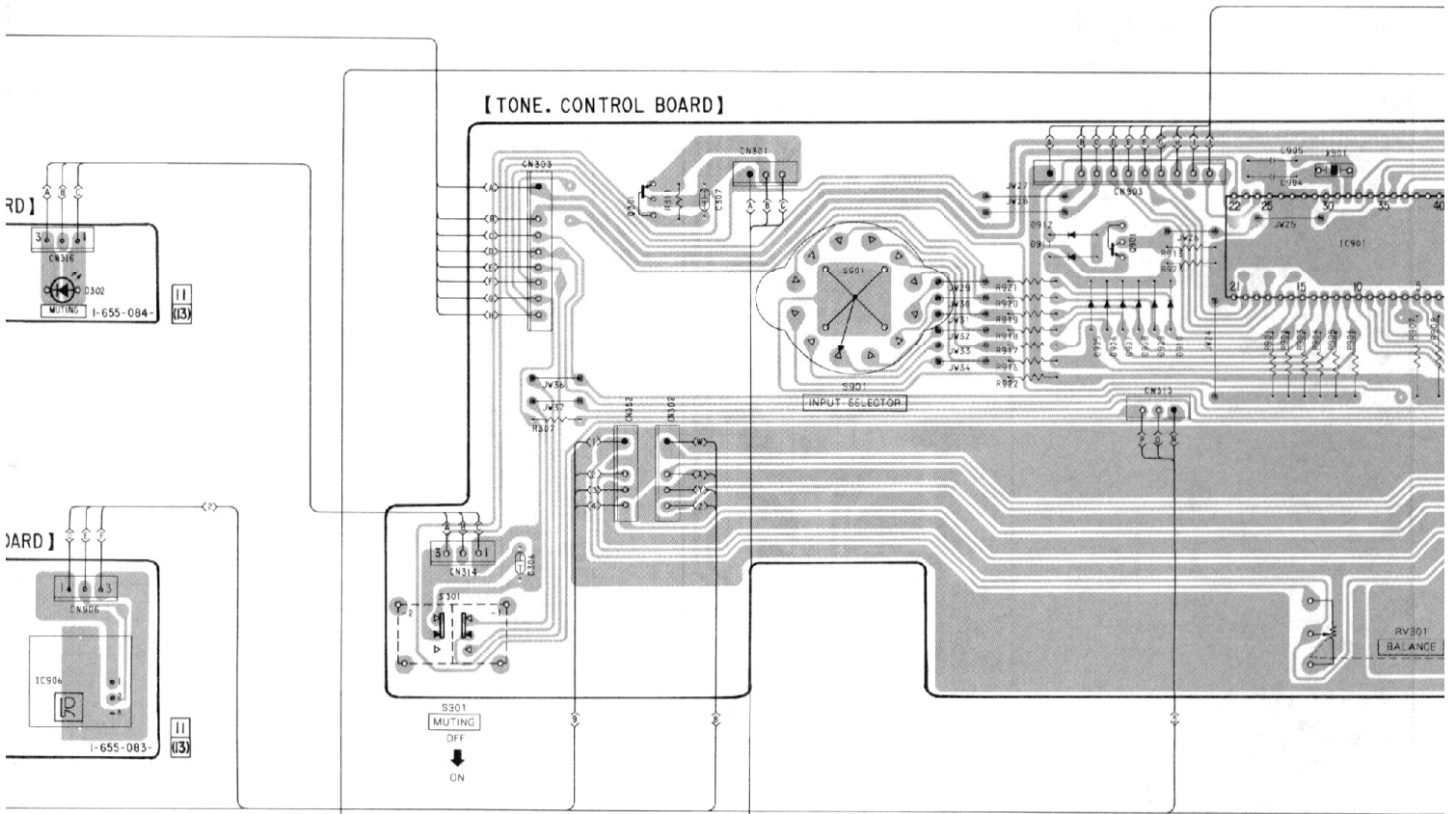

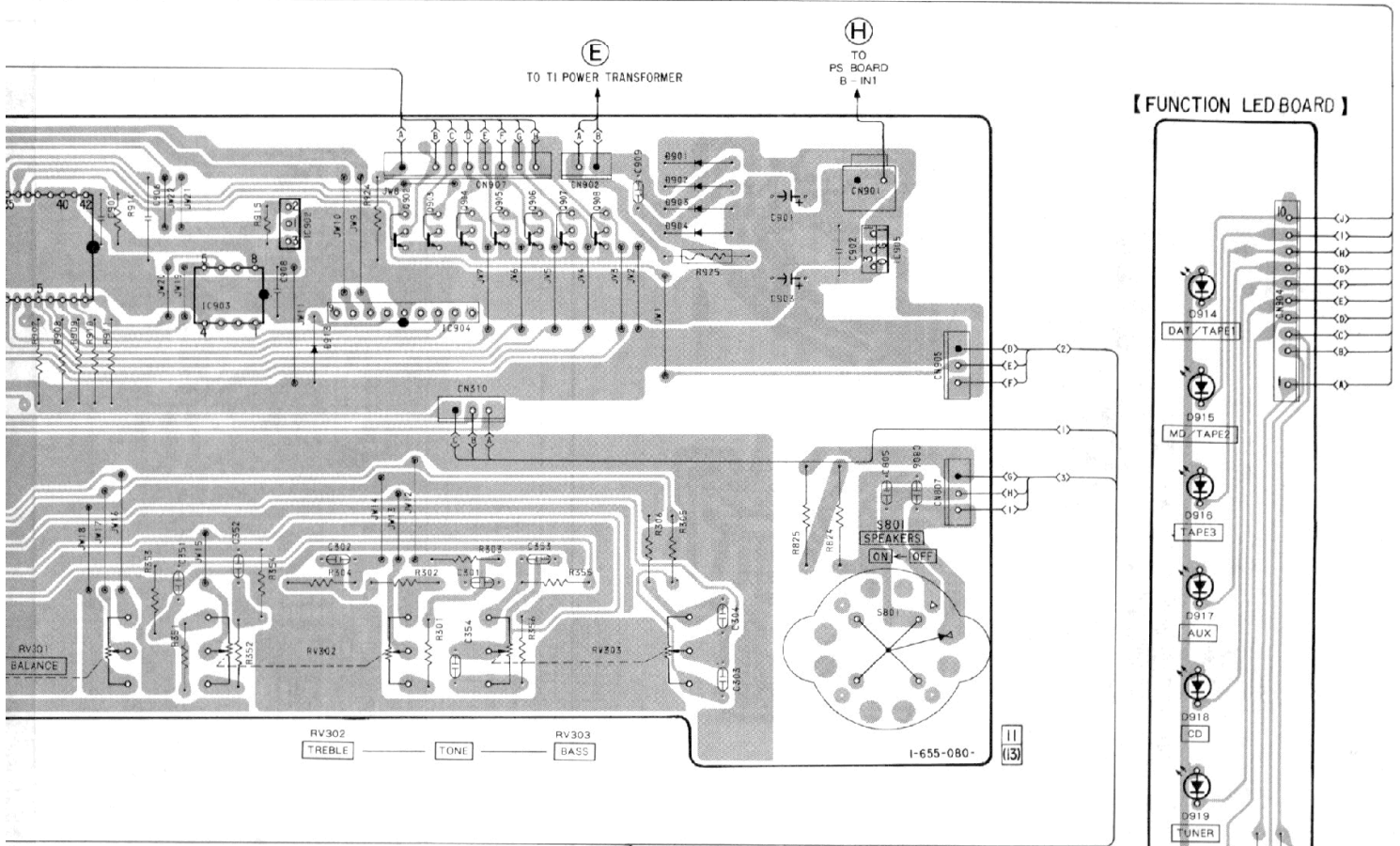

【FUNCTION LED BOARD】

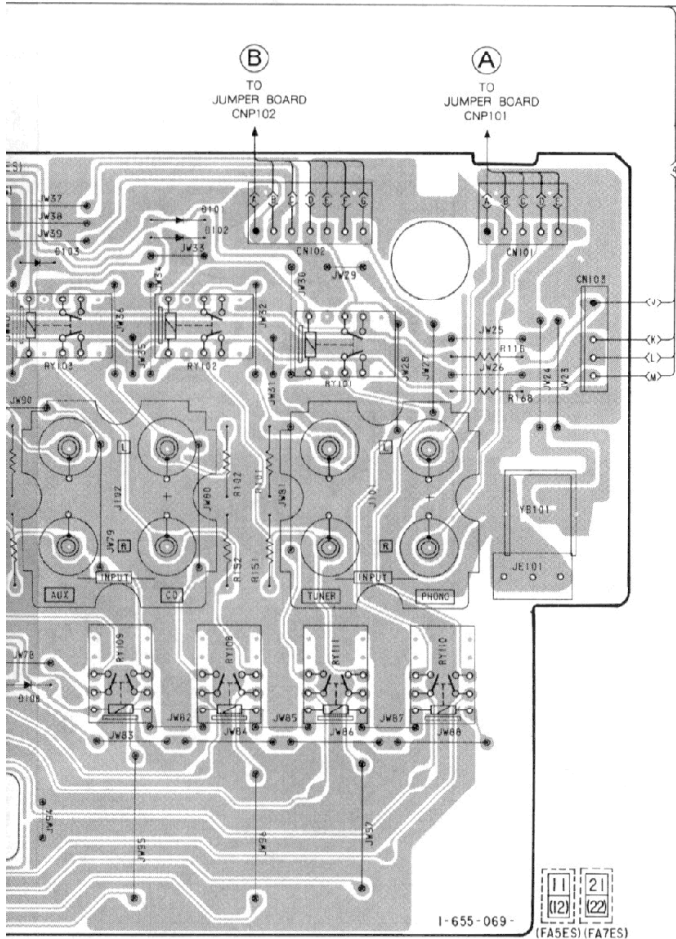
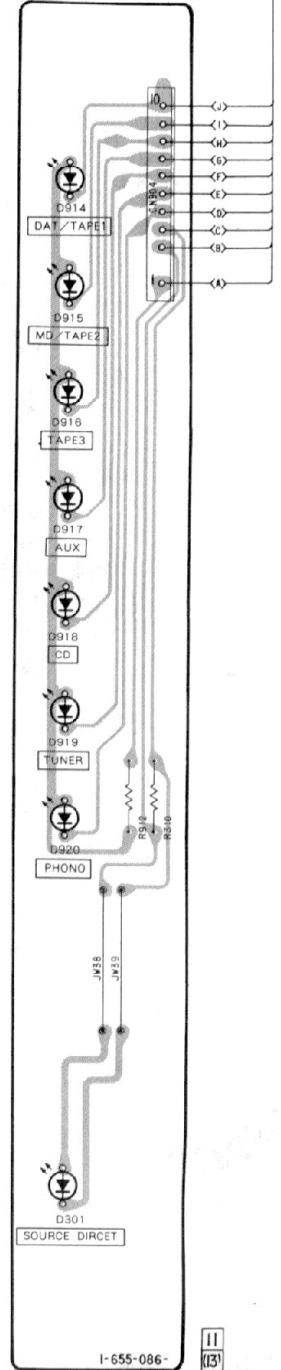

SECTION 5 EXPLODED VIEWS

NOTE:

- -XX and -X mean standardized parts, so they may have some difference from the original one.
- Color Indication of Appearance Parts
Example:
KNOB, BALANCE (WHITE) ... (RED)

↑
↑
 Parts Color Cabinet's Color

- Items marked "*" are not stocked since they are seldom required for routine service. Some delay should be anticipated when ordering these items.
- The mechanical parts with no reference number in the exploded views are not supplied.
- Hardware (# mark) list and accessories and packing materials are given in the last of the electrical parts list.

The components identified by mark or dotted line with mark are critical for safety. Replace only with part number specified.

(1) CABINET SECTION

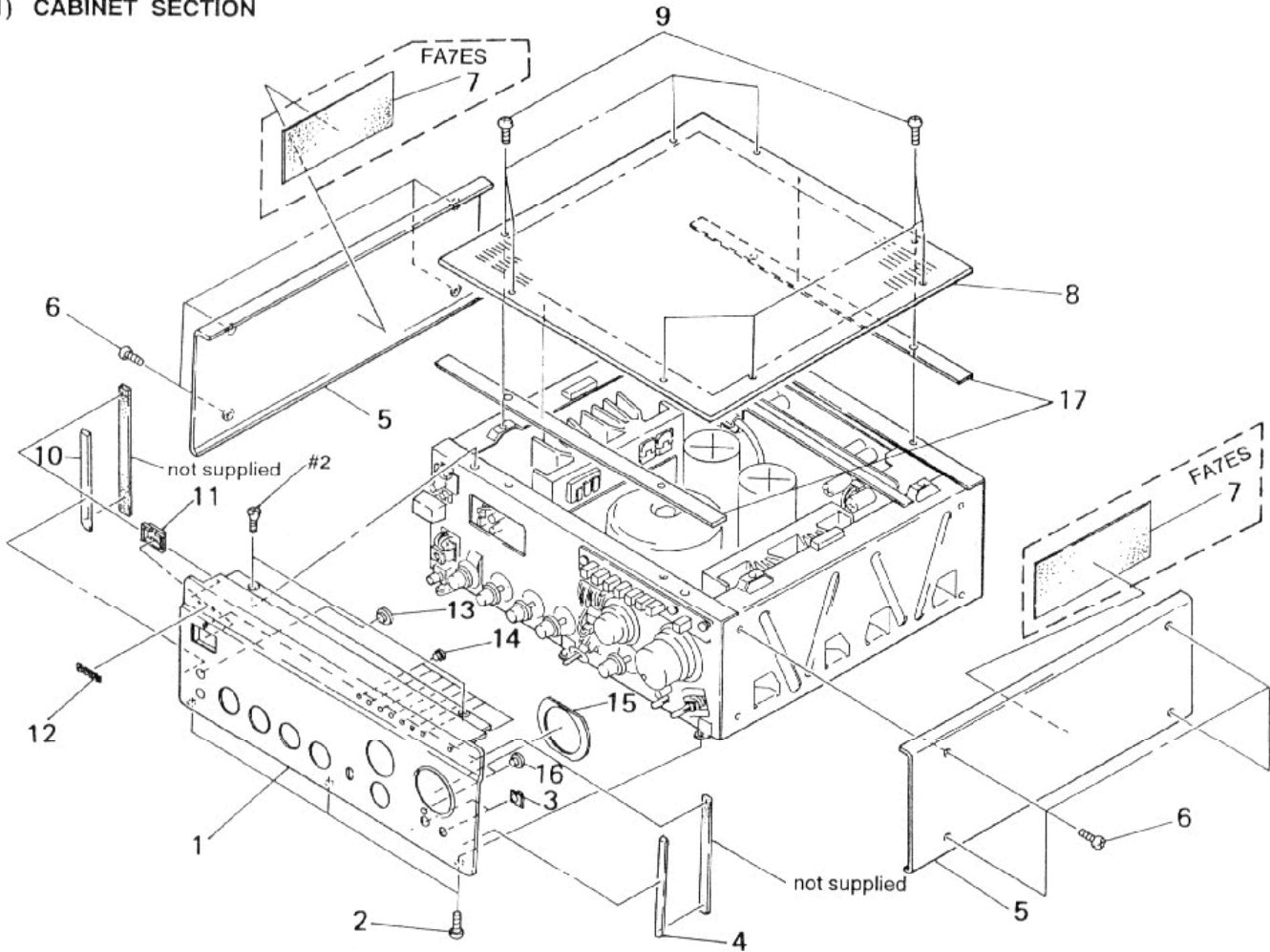

Ref. No.	Part No.	Description	Remark	Ref. No.	Part No.	Description	Remark
1	4-970-139-41	PANEL, FRONT (FA5ES:BLACK)		9	4-921-439-11	SCREW (M3X8), FLAT HEAD (GOLD)	
1	4-970-139-51	PANEL, FRONT (FA5ES:GOLD)		9	4-921-439-21	SCREW (M3X8), FLAT HEAD (BLACK)	
1	4-970-139-61	PANEL, FRONT (FA7ES:BLACK)		10	4-970-141-01	PLATE (L), ORNAMENTAL (BLACK)	
1	4-970-139-71	PANEL, FRONT (FA7ES:GOLD)		10	4-970-141-11	PLATE (L), ORNAMENTAL (GOLD)	
2	3-703-685-21	SCREW (+BV 3X8)		11	4-921-415-04	ESCUTCHEON, POWER KNOB (BLACK)	
3	4-970-145-01	ESCUTCHEON (P) (BLACK)		11	4-921-415-13	ESCUTCHEON, POWER KNOB (GOLD)	
3	4-970-145-11	ESCUTCHEON (P) (GOLD)		12	4-942-568-01	EMBLEM (NO. 5), SONY (BLACK)	
4	4-970-142-01	PLATE (R), ORNAMENTAL (BLACK)		12	4-942-568-21	EMBLEM (NO. 5), SONY (GOLD)	
4	4-970-142-11	PLATE (R), ORNAMENTAL (GOLD)		13	4-970-143-01	WINDOW, LAY CATCHER (BLACK)	
5	4-970-140-01	PANEL, SIDE (BLACK)		13	4-970-143-11	WINDOW, LAY CATCHER (GOLD)	
5	4-970-140-11	PANEL, SIDE (GOLD)		14	4-969-325-11	LENS, LED	
6	4-924-242-11	SCREW (M3X6), FLAT HEAD (BLACK)		15	4-970-144-01	PLATE (V), ORNAMENTAL (BLACK)	
6	4-924-242-61	SCREW (M3X6), FLAT HEAD (GOLD)		15	4-970-144-11	PLATE (V), ORNAMENTAL (GOLD)	
7	4-971-842-01	FELT (FA7ES)		16	4-970-486-01	LENS, LED	
* 8	4-969-333-21	BOARD, TOP (BLACK)		17	4-969-347-01	CUSHION	
* 8	4-969-333-31	BOARD, TOP (GOLD)					

(2) FRONT PANEL SECTION

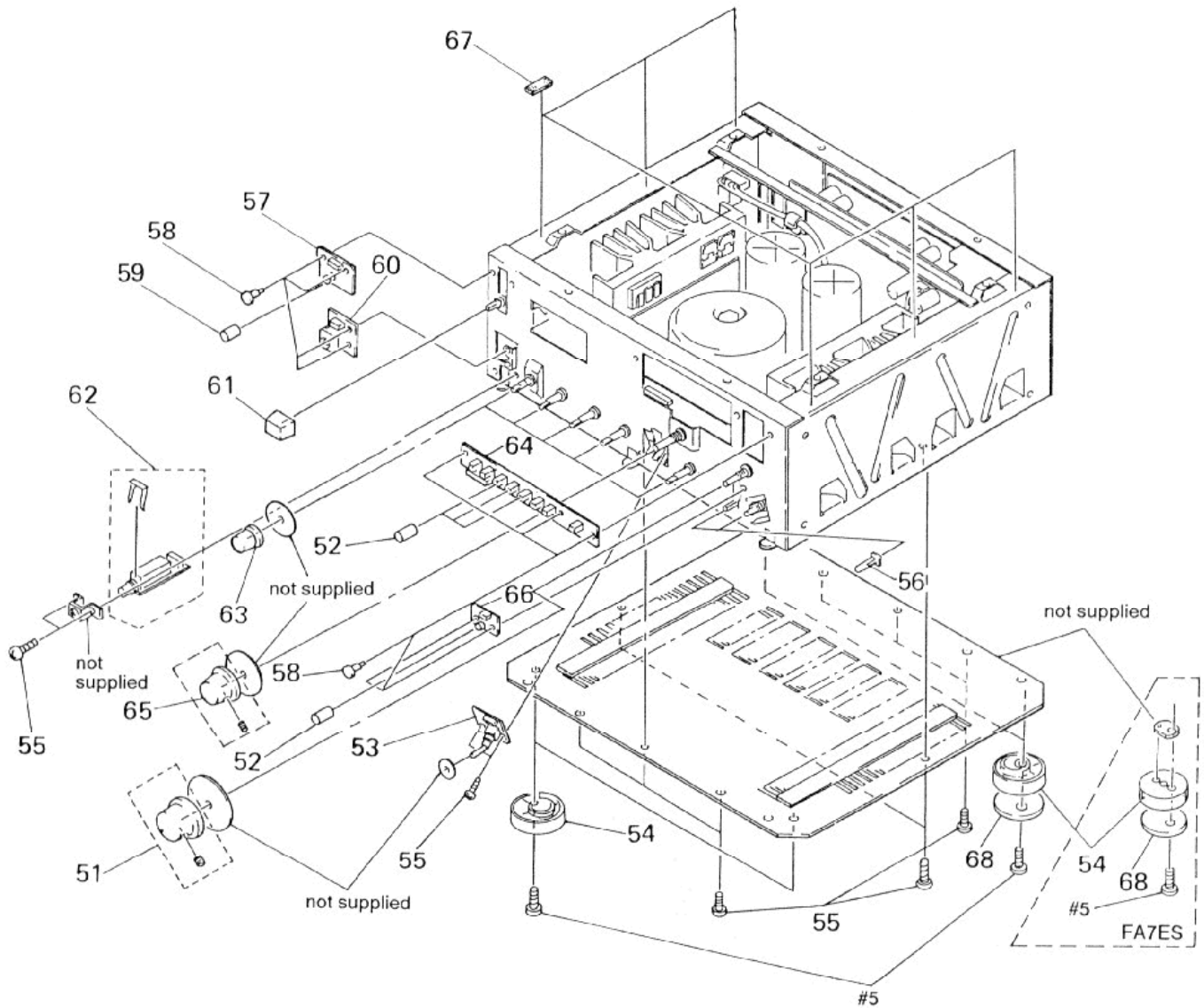

Ref. No.	Part No.	Description	Remark	Ref. No.	Part No.	Description	Remark
51	X-4945-357-1	KNOB (VB) ASSY (BLACK)		* 60	1-655-083-11	MEDAMA BOARD	
51	X-4945-359-1	KNOB (VG) ASSY (GOLD)		61	4-942-032-01	KNOB (POWER) (BLACK)	
+ 52	4-971-833-01	TUBE (A), LIGHT INTERCEPTION		61	4-942-032-11	KNOB (POWER) (GOLD)	
* 53	1-655-082-11	REC OUT BOARD		* 62	1-655-088-11	HP BOARD	
54	4-970-123-01	FOOT (F50180S) (FA5ES)		63	4-970-152-01	KNOB (R) (BLACK)	
54	4-970-487-01	FOOT (F50180S) (FA7ES)		63	4-970-152-11	KNOB (R) (GOLD)	
55	4-967-961-01	SCREW (3X8) (SPECIAL)		* 64	1-655-086-11	FUNCTION LED BOARD	
56	4-970-146-01	BUTTON (BLACK)		65	4-970-148-01	KNOB (I) (BLACK)	
56	4-970-146-11	BUTTON (GOLD)		65	4-970-148-11	KNOB (I) (GOLD)	
+ 57	1-655-085-11	PRO LED BOARD		* 66	1-655-084-11	MUT LED BOARD	
58	4-812-134-00	RIVET (DIA. 3.5), NYLON		67	4-969-896-01	SPACER	
+ 59	4-971-834-01	TUBE (B), LIGHT INTERCEPTION		68	4-972-889-01	CUSHION	

(3) CHASSIS SECTION

Note: The components identified by mark \triangle or dotted line with mark \triangle are critical for safety.
Replace only with part number specified.

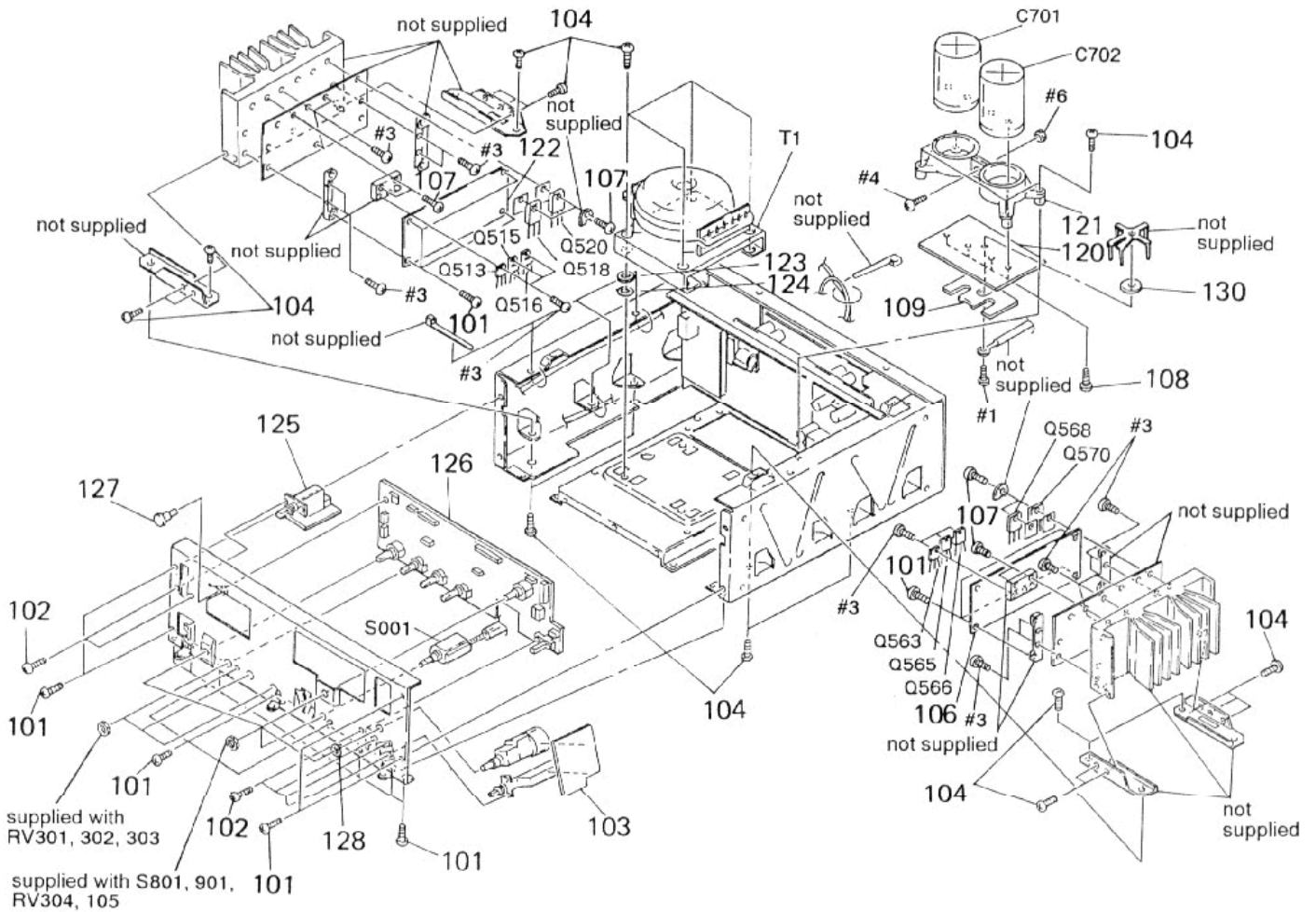

Ref. No.	Part No.	Description	Remark
101	4-967-961-01	SCREW (3X8) (SPECIAL)	
102	4-967-959-01	SCREW (3X6)	
* 103	1-655-087-11	VOL BOARD	
104	4-967-960-01	SCREW (4X8)	
* 106	1-655-075-11	MAIN B-R BOARD (FA5ES)	
* 106	1-655-075-21	MAIN B-R BOARD (FA7ES)	
107	4-956-589-01	SCREW(3X14), +B(COPPER PLATING)	
* 108	4-931-964-01	SCREW (M4X6)	
* 109	1-655-076-11	PS JUMPER BOARD (FA5ES)	
* 109	1-655-076-21	PS JUMPER BOARD (FA7ES)	
* 120	1-655-078-11	PS BOARD (FA5ES)	
* 120	1-655-078-21	PS BOARD (FA7ES)	
* 121	4-970-132-01	HOLDER (C)	
* 122	1-655-074-11	MAIN B-L BOARD (FA5ES)	
* 122	1-655-074-21	MAIN B-L BOARD (FA7ES)	
* 123	3-333-771-01	WASHER	
* 124	3-576-989-01	SHEET, ADHESIVE	
* 125	1-655-081-11	AC SW BOARD	
* 126	A-4371-831-A	ONE CONTROL BOARD, COMPLETE	
127	4-812-134-00	RIVET (DIA. 3.5), NYLON	
128	4-972-113-01	WASHER	
* 130	3-555-872-21	SPACER	

Ref. No.	Part No.	Description	Remark
C701	1-104-902-11	CAP, ELECT 15000uF (FA7ES)	
C701	1-107-845-12	CAP, ELECT 12000uF (FA5ES)	
C702	1-104-902-11	CAP, ELECT 15000uF (FA7ES)	
C702	1-107-845-12	CAP, ELECT 12000uF (FA5ES)	
Q513	8-729-203-45	TRANSISTOR 2SC3423-0	
Q515	8-729-018-19	TRANSISTOR 2SK2013-Y	
Q516	8-729-018-21	TRANSISTOR 2SJ313-Y	
Q518	8-729-018-11	TRANSISTOR 2SK1530A-Y (FA7ES)	
Q518	8-729-030-14	TRANSISTOR 2SK1530B-Y (FA5ES)	
Q520	8-729-018-13	TRANSISTOR 2SJ201A-Y (FA7ES)	
Q520	8-729-030-15	TRANSISTOR 2SJ201B-Y (FA5ES)	
Q563	8-729-203-45	TRANSISTOR 2SC3423-0	
Q565	8-729-018-19	TRANSISTOR 2SK2013-Y	
Q566	8-729-018-21	TRANSISTOR 2SJ313-Y	
Q568	8-729-018-11	TRANSISTOR 2SK1530A-Y (FA7ES)	
Q568	8-729-030-14	TRANSISTOR 2SK1530B-Y (FA5ES)	
Q570	8-729-018-13	TRANSISTOR 2SJ201A-Y (FA7ES)	
Q570	8-729-030-15	TRANSISTOR 2SJ201B-Y (FA5ES)	
S001	1-762-185-11	SWITCH, ROTARY SLIDE (REC OUT SELECTOR)	
\triangle T1	1-429-111-11	TRANSFORMER, POWER (FA5ES)	
\triangle T1	1-429-112-11	TRANSFORMER, POWER (FA7ES)	

(4) BACK PANEL SECTION

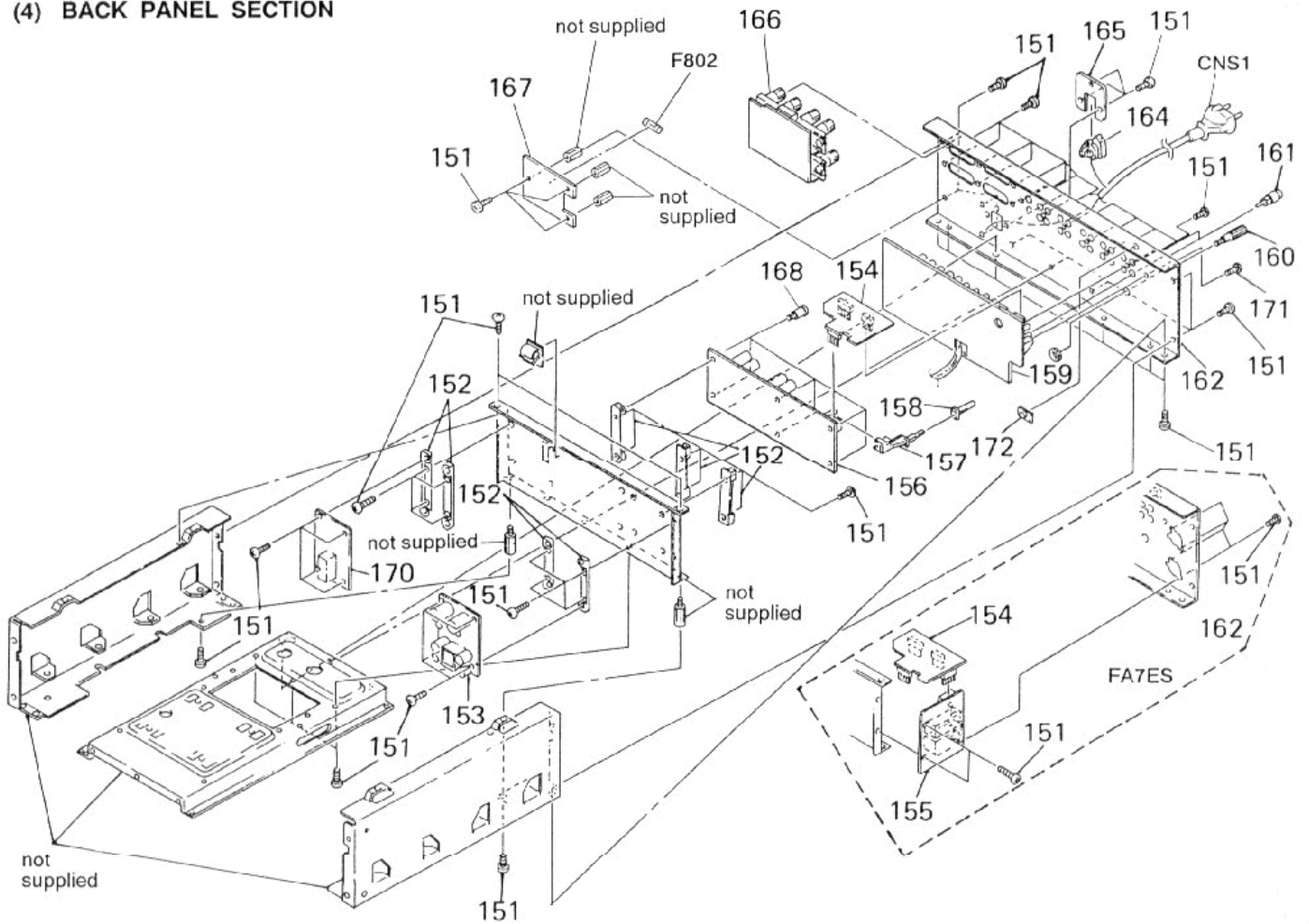

Note: The components identified by mark ⚠ or dotted line with mark ⚠ are critical for safety. Replace only with part number specified.

Ref. No.	Part No.	Description	Remark
	151	4-967-961-01 SCREW (3X8) (SPECIAL)	
*	152	4-969-344-01 HOLDER (P) (FA7ES)	
*	153	1-655-077-11 PRE PS BOARD (FA5ES)	
*	153	1-655-077-21 PRE PS BOARD (FA7ES)	
*	154	1-655-361-11 JUMPER BOARD (FA5ES)	
*	154	1-655-361-21 JUMPER BOARD (FA7ES)	
*	155	A-4378-510-A BALANCE BOARD, COMPLETE (FA7ES)	
*	156	A-4378-507-A MAIN. A BOARD, COMPLETE (FA5ES)	
*	156	A-4378-519-A MAIN. A BOARD, COMPLETE (FA7ES)	
*	157	4-970-147-01 ROD	
	158	4-970-146-01 BUTTON (BLACK)	
*	159	A-4378-506-A INPUT BOARD, COMPLETE (FA5ES)	
*	159	A-4378-518-A INPUT BOARD, COMPLETE (FA7ES)	
*	160	1-535-691-21 TERMINAL (FA5ES)	
*	160	1-535-691-31 TERMINAL (FA7ES)	
	161	1-506-113-00 SHORT PLUG	

Ref. No.	Part No.	Description	Remark
*	162	4-975-263-01 PANEL, BACK (FA5ES)	
*	162	4-975-263-11 PANEL, BACK (FA7ES)	
	164	2-352-626-01 BUSHING, CORD	
*	165	4-923-873-01 BRACKET, CORD STOPPER	
*	166	1-655-072-11 SP-TM BOARD (FA5ES)	
*	166	1-655-072-21 SP-TM BOARD (FA7ES)	
*	167	1-655-071-11 OUT LET BOARD	
	168	4-973-106-01 SCREW, COLLAR	
*	170	A-4378-503-A PRO BOARD, COMPLETE (FA5ES)	
*	170	A-4378-516-A PRO BOARD, COMPLETE (FA7ES)	
	171	3-703-685-21 SCREW (+BV 3X8)	
	172	4-970-145-01 ESCUTCHEON (P) (BLACK)	
⚠	CNS1	1-575-953-11 CORD, POWER	
⚠	F802	1-532-299-00 FUSE, TIME-LAG (T5A 250V) (FA7ES)	
⚠	F802	1-532-350-00 FUSE, TIME-LAG (T4A 250V) (FA5ES)	

SECTION 6 ELECTRICAL PARTS LIST

AC SW

BALANCE

FUNCTION LED

NOTE:

- Due to standardization, replacements in the parts list may be different from the parts specified in the diagrams or the components used on the set.
- -XX and -X mean standardized parts, so they may have some difference from the original one.
- RESISTORS
All resistors are in ohms.
METAL: Metal-film resistor.
METAL OXIDE: Metal oxide-film resistor.
F: nonflammable

- Items marked "*" are not stocked since they are seldom required for routine service. Some delay should be anticipated when ordering these items.
- SEMICONDUCTORS
In each case, u: μ , for example:
uA ..: μ A. uPA ..: μ PA.
uPB ..: μ PB. uPC ..: μ PC. uPD ..: μ PD.
- CAPACITORS
uF: μ F
- COILS
uH: μ H

The components identified by mark Δ or dotted line with mark Δ are critical for safety. Replace only with part number specified.

When indicating parts by reference number, please include the board.

Ref. No.	Part No.	Description	Remark	Ref. No.	Part No.	Description	Remark
*	1-655-081-11	AC SW BOARD *****				< TRANSISTOR >	
		< CONNECTOR >		Q206	8-729-030-18	TRANSISTOR 2SD2525	
CN4	1-580-629-11	PIN, CONNECTOR 2P < SWITCH >		Q207	8-729-281-54	TRANSISTOR 2SC1815-BL	
Δ S1	1-554-538-00	SWITCH, PUSH (AC POWER) (1 KEY) (POWER) *****		Q208	8-729-202-67	TRANSISTOR 2SK246-GR3	
*	A-4378-510-A	BALANCE BOARD, COMPLETE (FA7ES) *****		Q209	8-729-030-18	TRANSISTOR 2SD2525	
		< CAPACITOR >		Q256	8-729-030-19	TRANSISTOR 2SB1640	
C208	1-110-397-11	ELECT 1000uF 20% 63V		Q257	8-729-201-53	TRANSISTOR 2SA1015-GR	
C209	1-110-393-11	ELECT 100uF 20% 63V		Q258	8-729-202-67	TRANSISTOR 2SK246-GR3	
C210	1-110-390-11	ELECT 22uF 20% 63V		Q259	8-729-030-19	TRANSISTOR 2SB1640	
C211	1-110-390-11	ELECT 22uF 20% 63V				< RESISTOR >	
C258	1-110-397-11	ELECT 1000uF 20% 63V		R210	1-249-931-11	CARBON 2.2K 5% 1/4W	
C259	1-110-393-11	ELECT 100uF 20% 63V		R218	1-259-171-21	CARBON 1.5K 5% 1/4W	
C260	1-110-390-11	ELECT 22uF 20% 63V		Δ R220	1-219-022-11	FUSIBLE 100 5% 1/2W F	
C261	1-110-390-11	ELECT 22uF 20% 63V		Δ R221	1-219-022-11	FUSIBLE 100 5% 1/2W F	
		< CONNECTOR >		Δ R222	1-219-022-11	FUSIBLE 100 5% 1/2W F	
* CN202	1-565-480-11	CONNECTOR, BOARD TO BOARD 4P		Δ R223	1-219-022-11	FUSIBLE 100 5% 1/2W F	
CN204	1-691-765-21	PLUG (MICRO CONNECTOR) 3P		R224	1-124-995-11	CARBON 1M 5% 1/4W	
CNP201	1-766-803-11	CONNECTOR (CANON)		R260	1-249-931-11	CARBON 2.2K 5% 1/4W	
CNP251	1-766-803-11	CONNECTOR (CANON)		R268	1-259-171-21	CARBON 1.5K 5% 1/4W	
		< COMPOSITION CIRCUIT BLOCK >		Δ R270	1-219-022-11	FUSIBLE 100 5% 1/2W F	
CP201	1-233-250-11	ENCAPSULATED COMPONENT		Δ R271	1-219-022-11	FUSIBLE 100 5% 1/2W F	
		< DIODE >		Δ R272	1-219-022-11	FUSIBLE 100 5% 1/2W F	
D201	8-719-000-93	DIODE UZL-7H1		Δ R273	1-219-022-11	FUSIBLE 100 5% 1/2W F	
D202	8-719-000-93	DIODE UZL-7H1		R274	1-124-995-11	CARBON 1M 5% 1/4W	
D251	8-719-000-93	DIODE UZL-7H1				*****	
D252	8-719-000-93	DIODE UZL-7H1		*	1-655-086-11	FUNCTION LED BOARD *****	
		< DIODE >				< CONNECTOR >	
				CN904	1-691-772-11	PLUG (MICRO CONNECTOR) 10P	
D301	8-719-301-49	LED SEL2810A (SURCE DIRECT)				< DIODE >	
D914	8-719-313-72	LED SEL3810A-CD (DAT/TAPE1)					
D915	8-719-313-72	LED SEL3810A-CD (MD/TAPE2)					
D916	8-719-313-72	LED SEL3810A-CD (TAPE3)					
D917	8-719-313-72	LED SEL3810A-CD (AUX)					

FUNCTION LED

HP

INPUT

Ref. No.	Part No.	Description	Remark
D918	8-719-313-72	LED SEL3810A-CD (CD)	
D919	8-719-313-72	LED SEL3810A-CD (TUNER)	
D920	8-719-313-72	LED SEL3810A-CD (PHONO)	
< RESISTOR >			
R310	1-249-407-11	CARBON 150 5% 1/4W	
R912	1-249-411-11	CARBON 330 5% 1/4W	

*	1-655-088-11	HP BOARD	

< CONNECTOR >			
* CN808	1-564-506-11	PLUG, CONNECTOR 3P	
< JACK >			
J801	1-507-796-71	JACK (PHONES)	

*	A-4378-506-A	INPUT BOARD, COMPLETE (FA5ES)	
*	A-4378-518-A	INPUT BOARD, COMPLETE (FA7ES)	

*	1-535-730-21	LEAD, JUMPER (OFC)	
< CONNECTOR >			
* CN101	1-565-481-11	CONNECTOR, BOARD TO BOARD 5P	
* CN102	1-565-483-11	CONNECTOR, BOARD TO BOARD 7P	
CN103	1-691-766-21	PLUG (MICRO CONNECTOR) 4P	
CN104	1-691-770-11	PLUG (MICRO CONNECTOR) 8P	
CN105	1-691-765-11	PLUG (MICRO CONNECTOR) 3P	
CN106	1-564-505-11	PLUG, CONNECTOR 2P	
CN611	1-691-766-11	PLUG (MICRO CONNECTOR) 4P	
< DIODE >			
D101	8-719-987-63	DIODE 1N4148M	
D102	8-719-987-63	DIODE 1N4148M	
D103	8-719-987-63	DIODE 1N4148M	
D104	8-719-987-63	DIODE 1N4148M	
D105	8-719-987-63	DIODE 1N4148M	
D106	8-719-987-63	DIODE 1N4148M	
D107	8-719-987-63	DIODE 1N4148M	
D108	8-719-987-63	DIODE 1N4148M	
D109	8-719-000-93	DIODE UZL-7H1	
< JACK >			
J101	1-766-895-21	JACK, PIN 4P (PHONO TUNER)	
J102	1-766-895-21	JACK, PIN 4P (AUX CD)	
J103	1-766-895-11	JACK, PIN 4P (TAPE-3) (FA5ES)	
J103	1-766-895-21	JACK, PIN 4P (TAPE-3) (FA7ES)	

Ref. No.	Part No.	Description	Remark
J104	1-766-895-11	JACK, PIN 4P (MD/TAPE-2) (FA5ES)	
J104	1-766-895-21	JACK, PIN 4P (MD/TAPE-2) (FA7ES)	
J105	1-766-895-11	JACK, PIN 4P (DAT/TAPE-1) (FA5ES)	
J105	1-766-895-21	JACK, PIN 4P (DAT/TAPE-1) (FA7ES)	
J106	1-766-894-31	JACK 2P (PRE OUT) (FA5ES)	
J106	1-766-894-41	JACK 2P (PRE OUT) (FA7ES)	
< PHOTO INTERRUPTER >			
PH101	8-719-946-27	DIODE PC837	
PH102	8-719-936-58	PHOTO COUPLER PC847-BC	
< TRANSISTOR >			
Q101	8-729-281-54	TRANSISTOR 2SC1815-BL	
Q102	8-729-281-54	TRANSISTOR 2SC1815-BL	
Q103	8-729-281-54	TRANSISTOR 2SC1815-BL	
Q104	8-729-281-54	TRANSISTOR 2SC1815-BL	
Q105	8-729-281-54	TRANSISTOR 2SC1815-BL	
Q106	8-729-281-54	TRANSISTOR 2SC1815-BL	
Q107	8-729-281-54	TRANSISTOR 2SC1815-BL	
< RESISTOR >			
R101	1-124-995-11	CARBON 1M 5% 1/4W	
R102	1-124-995-11	CARBON 1M 5% 1/4W	
R103	1-124-995-11	CARBON 1M 5% 1/4W	
R104	1-259-167-21	CARBON 1K 5% 1/4W	
R105	1-124-995-11	CARBON 1M 5% 1/4W	
R106	1-259-167-21	CARBON 1K 5% 1/4W	
R107	1-124-995-11	CARBON 1M 5% 1/4W	
R108	1-259-167-21	CARBON 1K 5% 1/4W	
R109	1-124-995-11	CARBON 1M 5% 1/4W	
R111	1-259-167-21	CARBON 1K 5% 1/4W	
R112	1-259-167-21	CARBON 1K 5% 1/4W	
R113	1-259-167-21	CARBON 1K 5% 1/4W	
R114	1-259-167-21	CARBON 1K 5% 1/4W	
R115	1-259-167-21	CARBON 1K 5% 1/4W	
R116	1-259-167-21	CARBON 1K 5% 1/4W	
R117	1-259-167-21	CARBON 1K 5% 1/4W	
R118	1-259-143-21	CARBON 100 5% 1/4W	
R119	1-124-995-11	CARBON 1M 5% 1/4W	
R120	1-124-995-11	CARBON 1M 5% 1/4W	
R121	1-124-995-11	CARBON 1M 5% 1/4W	
R122	1-249-226-11	CARBON 4.7K 5% 1/3W	
R123	1-249-194-11	CARBON 220 5% 1/3W	
R151	1-124-995-11	CARBON 1M 5% 1/4W	
R152	1-124-995-11	CARBON 1M 5% 1/4W	
R153	1-124-995-11	CARBON 1M 5% 1/4W	
R154	1-259-167-21	CARBON 1K 5% 1/4W	
R155	1-124-995-11	CARBON 1M 5% 1/4W	

INPUT

JUMPER

MAIN. A

Ref. No.	Part No.	Description	Remark		
R156	1-259-167-21	CARBON	1K	5%	1/4W
R157	1-124-995-11	CARBON	1M	5%	1/4W
R158	1-259-167-21	CARBON	1K	5%	1/4W
R159	1-124-995-11	CARBON	1M	5%	1/4W
R168	1-259-143-21	CARBON	100	5%	1/4W
R169	1-124-995-11	CARBON	1M	5%	1/4W
R170	1-124-995-11	CARBON	1M	5%	1/4W
R171	1-124-995-11	CARBON	1M	5%	1/4W
R172	1-249-226-11	CARBON	4.7K	5%	1/3W
R173	1-249-194-11	CARBON	220	5%	1/3W
< RELAY >					
RY101	1-755-060-11	RELAY			
RY102	1-755-060-11	RELAY			
RY103	1-755-060-11	RELAY			
RY104	1-755-060-11	RELAY			
RY105	1-755-060-11	RELAY			
RY106	1-755-060-11	RELAY			
RY107	1-755-060-11	RELAY			
RY108	1-755-060-11	RELAY			
RY109	1-755-060-11	RELAY			
RY110	1-755-060-11	RELAY			
RY111	1-755-060-11	RELAY			
< SWITCH >					
S101	1-570-076-11	SWITCH, SLIDE (REMOTE TYPE) (REC OUT SELECTOR)			
S102	1-762-181-11	SWITCH, SLIDE (AUX INPUT) (FA7ES)			
< BRACKET >					
* YB101	4-946-336-01	BRACKET (GROUND)			

*	1-655-361-11	JUMPER BOARD (FA5ES)			
*	1-655-361-21	JUMPER BOARD (FA7ES)			

< CONNECTOR >					
* CNP101	1-560-531-11	PIN, CONNECTOR 5P			
* CNP102	1-560-532-00	PIN, CONNECTOR 7P			
* CNP103	1-506-509-11	PIN, CONNECTOR 4P (FA7ES)			
* CNP104	1-560-532-00	PIN, CONNECTOR 7P			

*	A-4378-507-A	MAIN. A BOARD, COMPLETE (FA5ES)			
*	A-4378-519-A	MAIN. A BOARD, COMPLETE (FA7ES)			

*	1-535-730-21	LEAD, JUMPER (0FC)			

Ref. No.	Part No.	Description	Remark		
< CAPACITOR >					
C201	1-104-290-11	POLYSTYRENE 330PF	5%		50V
C202	1-130-973-00	FILM 0.022uF	2%		100V
C203	1-130-341-00	FILM 0.056uF	2%		100V
C204	1-130-971-00	FILM 0.016uF	2%		100V
C205	1-124-929-11	ELECT 22uF	20%		100V (FA5ES)
C205	1-110-390-11	ELECT 22uF	20%		63V (FA7ES)
C206	1-124-929-11	ELECT 22uF	20%		100V (FA5ES)
C206	1-110-390-11	ELECT 22uF	20%		63V (FA7ES)
C207	1-124-929-11	ELECT 22uF	20%		100V (FA5ES)
C207	1-110-390-11	ELECT 22uF	20%		63V (FA7ES)
C251	1-104-290-11	POLYSTYRENE 330PF	5%		50V
C252	1-130-973-00	FILM 0.022uF	2%		100V
C253	1-130-341-00	FILM 0.056uF	2%		100V
C254	1-130-971-00	FILM 0.016uF	2%		100V
C255	1-124-929-11	ELECT 22uF	20%		100V (FA5ES)
C255	1-110-390-11	ELECT 22uF	20%		63V (FA7ES)
C256	1-124-929-11	ELECT 22uF	20%		100V (FA5ES)
C256	1-110-390-11	ELECT 22uF	20%		63V (FA7ES)
C257	1-124-929-11	ELECT 22uF	20%		100V (FA5ES)
C257	1-110-390-11	ELECT 22uF	20%		63V (FA7ES)
C401	1-104-274-11	POLYSTYRENE 47PF	10%		50V (FA5ES)
C401	1-104-322-11	POLYSTYRENE 47PF	10%		400V (FA7ES)
C402	1-136-810-11	FILM 220PF	5%		100V
C405	1-126-025-11	ELECT 330uF	20%		25V
C406	1-126-025-11	ELECT 330uF	20%		25V
C408	1-110-390-11	ELECT 22uF	20%		63V
C409	1-110-512-11	FILM 1uF	10%		50V (FA7ES)
C410	1-104-274-11	POLYSTYRENE 47PF	10%		50V (FA5ES)
C410	1-104-322-11	POLYSTYRENE 47PF	10%		400V (FA7ES)
C411	1-126-025-11	ELECT 330uF	20%		25V
C412	1-126-025-11	ELECT 330uF	20%		25V
C413	1-110-390-11	ELECT 22uF	20%		63V
C418	1-110-397-11	ELECT 1000uF	20%		63V
C419	1-110-397-11	ELECT 1000uF	20%		63V
C425	1-128-474-11	ELECT 1000uF	20%		63V
C426	1-128-474-11	ELECT 1000uF	20%		63V
C451	1-104-274-11	POLYSTYRENE 47PF	10%		50V (FA5ES)
C451	1-104-322-11	POLYSTYRENE 47PF	10%		400V (FA7ES)
C452	1-136-810-11	FILM 220PF	5%		100V
C455	1-126-025-11	ELECT 330uF	20%		25V
C456	1-126-025-11	ELECT 330uF	20%		25V
C458	1-110-390-11	ELECT 22uF	20%		63V
C459	1-110-512-11	FILM 1uF	10%		50V (FA7ES)
C460	1-104-274-11	POLYSTYRENE 47PF	10%		50V (FA5ES)
C460	1-104-322-11	POLYSTYRENE 47PF	10%		400V (FA7ES)
C461	1-126-025-11	ELECT 330uF	20%		25V
C462	1-126-025-11	ELECT 330uF	20%		25V

MAIN. A

Ref.No.	Part No.	Description	Remark	Ref.No.	Part No.	Description	Remark
C463	1-110-390-11	ELECT 22uF 20%	63V	Q204	8-729-202-67	TRANSISTOR 2SK246-GR3	
C468	1-110-397-11	ELECT 1000uF 20%	63V	Q205	8-729-281-54	TRANSISTOR 2SC1815-BL	
C469	1-110-397-11	ELECT 1000uF 20%	63V	Q251	8-729-217-04	TRANSISTOR 2SK170-V (FA5ES)	
C475	1-128-474-11	ELECT 1000uF 20%	63V	Q251	8-729-214-71	TRANSISTOR 2SK147-GR (FA7ES)	
C476	1-128-474-11	ELECT 1000uF 20%	63V	Q252	8-729-217-04	TRANSISTOR 2SK170-V (FA5ES)	
< CONNECTOR >				Q252	8-729-214-71	TRANSISTOR 2SK147-GR (FA7ES)	
* CN201	1-565-483-11	CONNECTOR, BOARD TO BOARD 7P		Q253	8-729-203-45	TRANSISTOR 2SC3423-0	
* CN203	1-564-506-11	PLUG, CONNECTOR 3P		Q254	8-729-202-67	TRANSISTOR 2SK246-GR3	
CN401	1-691-766-11	PLUG (MICRO CONNECTOR) 4P		Q255	8-729-281-54	TRANSISTOR 2SC1815-BL	
CN402	1-691-766-31	PLUG (MICRO CONNECTOR) 4P		Q401	8-729-203-21	TRANSISTOR 2SK389-GR	
CN403	1-691-766-21	PLUG (MICRO CONNECTOR) 4P		Q402	8-729-281-54	TRANSISTOR 2SC1815-BL	
CN404	1-564-510-11	PLUG (MICRO CONNECTOR) 6P		Q403	8-729-281-54	TRANSISTOR 2SC1815-BL	
< DIODE >				Q404	8-729-232-00	TRANSISTOR 2SA1349-GRBL	
D401	8-719-933-41	DIODE HZS6C3L		Q405	8-729-018-21	TRANSISTOR 2SJ313-Y	
D402	8-719-987-63	DIODE 1N4148M (FA5ES)		Q406	8-729-104-91	TRANSISTOR 2SA1383-Q	
D402	8-719-200-02	DIODE 10E2 (FA7ES)		Q407	8-729-202-67	TRANSISTOR 2SK246-GR3	
D403	8-719-987-63	DIODE 1N4148M (FA5ES)		Q408	8-729-104-18	TRANSISTOR 2SC3514-Q	
D403	8-719-200-02	DIODE 10E2 (FA7ES)		Q409	8-729-104-18	TRANSISTOR 2SC3514-Q	
D418	8-719-987-63	DIODE 1N4148M (FA5ES)		Q410	8-729-202-67	TRANSISTOR 2SK246-GR3	
D418	8-719-200-02	DIODE 10E2 (FA7ES)		Q411	8-729-202-67	TRANSISTOR 2SK246-GR3	
D419	8-719-987-63	DIODE 1N4148M (FA5ES)		Q412	8-729-202-67	TRANSISTOR 2SK246-GR3	
D419	8-719-200-02	DIODE 10E2 (FA7ES)		Q451	8-729-203-21	TRANSISTOR 2SK389-GR	
D420	8-719-987-63	DIODE 1N4148M (FA5ES)		Q452	8-729-281-54	TRANSISTOR 2SC1815-BL	
D420	8-719-200-02	DIODE 10E2 (FA7ES)		Q453	8-729-281-54	TRANSISTOR 2SC1815-BL	
D451	8-719-933-41	DIODE HZS6C3L		Q454	8-729-232-00	TRANSISTOR 2SA1349-GRBL	
D452	8-719-987-63	DIODE 1N4148M (FA5ES)		Q455	8-729-018-21	TRANSISTOR 2SJ313-Y	
D452	8-719-200-02	DIODE 10E2 (FA7ES)		Q456	8-729-104-91	TRANSISTOR 2SA1383-Q	
D453	8-719-987-63	DIODE 1N4148M (FA5ES)		Q457	8-729-202-67	TRANSISTOR 2SK246-GR3	
D453	8-719-200-02	DIODE 10E2 (FA7ES)		Q458	8-729-104-18	TRANSISTOR 2SC3514-Q	
D468	8-719-987-63	DIODE 1N4148M (FA5ES)		Q459	8-729-104-18	TRANSISTOR 2SC3514-Q	
D468	8-719-200-02	DIODE 10E2 (FA7ES)		Q460	8-729-202-67	TRANSISTOR 2SK246-GR3	
D469	8-719-987-63	DIODE 1N4148M (FA5ES)		Q461	8-729-202-67	TRANSISTOR 2SK246-GR3	
D469	8-719-200-02	DIODE 10E2 (FA7ES)		Q462	8-729-202-67	TRANSISTOR 2SK246-GR3	
D470	8-719-987-63	DIODE 1N4148M (FA5ES)		< RESISTOR >			
D470	8-719-200-02	DIODE 10E2 (FA7ES)		R201	1-249-911-11	CARBON 330 5% 1/4W	
< IC >				R202	1-259-143-21	CARBON 100 5% 1/4W	
IC201	8-759-701-25	IC NJM2068D-D (FA5ES)		R203	1-259-207-21	CARBON 47K 5% 1/4W	
IC201	8-759-259-12	IC OPA2604AP (FA7ES)		R204	1-249-919-11	CARBON 680 5% 1/4W	
< TRANSISTOR >				R205	1-249-919-11	CARBON 680 5% 1/4W	
Q201	8-729-217-04	TRANSISTOR 2SK170-V (FA5ES)		R206	1-249-939-11	CARBON 4.7K 5% 1/4W	
Q201	8-729-214-71	TRANSISTOR 2SK147-GR (FA7ES)		R207	1-259-143-21	CARBON 100 5% 1/4W	
Q202	8-729-217-04	TRANSISTOR 2SK170-V (FA5ES)		R208	1-249-915-11	CARBON 470 5% 1/4W	
Q202	8-729-214-71	TRANSISTOR 2SK147-GR (FA7ES)		R209	1-259-143-21	CARBON 100 5% 1/4W	
Q203	8-729-203-45	TRANSISTOR 2SC3423-0		R210	1-249-485-11	CARBON 8.2 5% 1/3W	
				R211	1-249-887-11	CARBON 33 5% 1/4W	
				R212	1-259-151-21	CARBON 220 5% 1/4W	
				R213	1-259-151-21	CARBON 220 5% 1/4W	
				R214	1-124-995-11	CARBON 1M 5% 1/4W	

MAIN. A

MAIN B-L

Ref. No.	Part No.	Description	Remark
R215	1-249-844-11	CARBON	56K 1% 1/2W
R216	1-249-818-11	CARBON	4.7K 1% 1/2W
R217	1-259-151-21	CARBON	220 5% 1/4W
R251	1-249-911-11	CARBON	330 5% 1/4W
R252	1-259-143-21	CARBON	100 5% 1/4W
R253	1-259-207-21	CARBON	47K 5% 1/4W
R254	1-249-919-11	CARBON	680 5% 1/4W
R255	1-249-919-11	CARBON	680 5% 1/4W
R256	1-249-939-11	CARBON	4.7K 5% 1/4W
R257	1-259-143-21	CARBON	100 5% 1/4W
R258	1-249-915-11	CARBON	470 5% 1/4W
R259	1-259-143-21	CARBON	100 5% 1/4W
R260	1-249-485-11	CARBON	8.2 5% 1/3W
R261	1-249-887-11	CARBON	33 5% 1/4W
R262	1-259-151-21	CARBON	220 5% 1/4W
R263	1-259-151-21	CARBON	220 5% 1/4W
R264	1-124-995-11	CARBON	1M 5% 1/4W
R265	1-249-844-11	CARBON	56K 1% 1/2W
R266	1-249-818-11	CARBON	4.7K 1% 1/2W
R267	1-259-151-21	CARBON	220 5% 1/4W
R401	1-214-937-00	METAL	1M 1% 1/2W
R402	1-249-210-11	CARBON	1K 5% 1/3W
R403	1-249-883-11	CARBON	22 5% 1/4W
R404	1-249-883-11	CARBON	22 5% 1/4W
R405	1-249-931-11	CARBON	2.2K 5% 1/4W
R406	1-249-943-11	CARBON	6.8K 5% 1/4W
R407	1-259-151-21	CARBON	220 5% 1/4W
R408	1-259-151-21	CARBON	220 5% 1/4W
R409	1-259-151-21	CARBON	220 5% 1/4W
R410	1-259-207-21	CARBON	47K 5% 1/4W
R411	1-259-167-21	CARBON	1K 5% 1/4W
△R412	1-219-193-11	FUSIBLE	220 5% 1/2W F
R413	1-249-842-11	CARBON	47K 5% 1/2W
R414	1-259-171-21	CARBON	1.5K 5% 1/4W
R415	1-249-953-11	CARBON	18K 5% 1/4W
R416	1-249-186-11	CARBON	100 5% 1/3W
R417	1-249-234-11	CARBON	10K 5% 1/3W
R418	1-249-234-11	CARBON	10K 5% 1/3W
R419	1-214-937-00	METAL	1M 1% 1/2W
R420	1-259-171-21	CARBON	1.5K 5% 1/4W
R421	1-249-939-11	CARBON	4.7K 5% 1/4W
△R422	1-219-022-11	FUSIBLE	100 5% 1/2W F
△R444	1-219-022-11	FUSIBLE	100 5% 1/2W F
△R445	1-219-022-11	FUSIBLE	100 5% 1/2W F
R451	1-214-937-00	METAL	1M 1% 1/2W
R452	1-249-210-11	CARBON	1K 5% 1/3W
R453	1-249-883-11	CARBON	22 5% 1/4W
R454	1-249-883-11	CARBON	22 5% 1/4W

Ref. No.	Part No.	Description	Remark
R455	1-249-931-11	CARBON	2.2K 5% 1/4W
R456	1-249-943-11	CARBON	6.8K 5% 1/4W
R457	1-259-151-21	CARBON	220 5% 1/4W
R458	1-259-151-21	CARBON	220 5% 1/4W
R459	1-259-151-21	CARBON	220 5% 1/4W
R460	1-259-207-21	CARBON	47K 5% 1/4W
R461	1-259-167-21	CARBON	1K 5% 1/4W
△R462	1-219-193-11	FUSIBLE	220 5% 1/2W F
R463	1-249-842-11	CARBON	47K 5% 1/2W
R464	1-259-171-21	CARBON	1.5K 5% 1/4W
R465	1-249-953-11	CARBON	18K 5% 1/4W
R466	1-249-186-11	CARBON	100 5% 1/3W
R467	1-249-234-11	CARBON	10K 5% 1/3W
R468	1-249-234-11	CARBON	10K 5% 1/3W
R469	1-214-937-00	METAL	1M 1% 1/2W
R470	1-259-171-21	CARBON	1.5K 5% 1/4W
R471	1-249-939-11	CARBON	4.7K 5% 1/4W
△R472	1-219-022-11	FUSIBLE	100 5% 1/2W F
△R494	1-219-022-11	FUSIBLE	100 5% 1/2W F
△R495	1-219-022-11	FUSIBLE	100 5% 1/2W F

< SWITCH >

S201 1-572-642-11 SWITCH, PUSH (1 KEY) (CARTRIDGE)

* 1-655-074-11 MAIN B-L BOARD (FA5ES)

* 1-655-074-21 MAIN B-L BOARD (FA7ES)

< CAPACITOR >

C516	1-137-163-11	FILM	0.33uF	10%	63V
C517	1-137-163-11	FILM	0.33uF	10%	63V
C520	1-124-920-11	ELECT	330uF	20%	63V (FA5ES)
C520	1-110-391-11	ELECT	33uF	20%	63V (FA7ES)
C570	1-110-391-11	ELECT	33uF	20%	63V (FA7ES)

< CONNECTOR >

- * CN501 1-564-506-11 PLUG, CONNECTOR 3P
- * CN502 1-564-506-11 PLUG, CONNECTOR 3P
- CN503 1-766-897-21 PIN, CONNECTOR (PC BOARD) 4P

< DIODE >

D505	8-719-987-63	DIODE	1N4148M
D506	8-719-985-53	DIODE	HZS4ALL
D507	8-719-310-60	LED	SEL1510C-C
D511	8-719-987-63	DIODE	1N4148M
D512	8-719-985-53	DIODE	HZS4ALL
D513	8-719-987-63	DIODE	1N4148M
D514	8-719-987-63	DIODE	1N4148M

The components identified by mark △ or dotted line with mark. △ are critical for safety. Replace only with part number specified.

MAIN B-L

MAIN B-R

MEDAMA

MUT LED

OUT LET

Ref. No. Part No. Description Remark

< TRANSISTOR >

Q514 8-729-201-53 TRANSISTOR 2SA1015-GR
 Q521 8-729-140-82 TRANSISTOR 2SA988-PAFAEA

< RESISTOR >

R523 1-249-941-11 CARBON 5.6K 5% 1/4W
 R524 1-259-167-21 CARBON 1K 5% 1/4W
 R525 1-259-171-21 CARBON 1.5K 5% 1/4W
 △R526 1-202-954-11 FUSIBLE 470 5% 1/2W F
 △R527 1-202-954-11 FUSIBLE 470 5% 1/2W F
 △R528 1-219-193-11 FUSIBLE 220 5% 1/2W F
 △R529 1-219-185-11 FUSIBLE 47 5% 1/2W F
 △R532 1-219-185-11 FUSIBLE 47 5% 1/2W F
 R534 1-219-392-11 RES, WIREWOUND
 R535 1-249-951-11 CARBON 15K 5% 1/4W
 R536 1-259-191-21 CARBON 10K 5% 1/4W
 △R537 1-247-717-11 CARBON 2.2K 5% 1/4W F
 △R538 1-247-717-11 CARBON 2.2K 5% 1/4W F

< VARIABLE RESISTOR >

RT501 1-224-490-11 RES, ADJ, METAL FILM 4.7K

* 1-655-075-11 MAIN B-R BOARD (FA5ES)
 * 1-655-075-21 MAIN B-R BOARD (FA7ES)

< CAPACITOR >

C566 1-137-163-11 FILM 0.33uF 10% 63V
 C567 1-137-163-11 FILM 0.33uF 10% 63V
 C570 1-124-920-11 ELECT 330uF 20% 63V (FA5ES)

< CONNECTOR >

* CN551 1-564-506-11 PLUG, CONNECTOR 3P
 * CN552 1-564-506-11 PLUG, CONNECTOR 3P
 CN553 1-766-897-11 PIN, CONNECTOR (PC BOARD) 4P

< DIODE >

D555 8-719-987-63 DIODE 1N4148M
 D556 8-719-985-53 DIODE HZS4ALL
 D557 8-719-310-60 LED SEL1510C-C
 D561 8-719-987-63 DIODE 1N4148M
 D562 8-719-985-53 DIODE HZS4ALL
 D564 8-719-987-63 DIODE 1N4148M
 D565 8-719-987-63 DIODE 1N4148M

< TRANSISTOR >

Q564 8-729-201-53 TRANSISTOR 2SA1015-GR

Ref. No. Part No. Description Remark

Q571 8-729-140-82 TRANSISTOR 2SA988-PAFAEA

< RESISTOR >

R573 1-249-941-11 CARBON 5.6K 5% 1/4W
 R574 1-259-167-21 CARBON 1K 5% 1/4W
 R575 1-259-171-21 CARBON 1.5K 5% 1/4W
 △R576 1-202-954-11 FUSIBLE 470 5% 1/2W F
 △R577 1-202-954-11 FUSIBLE 470 5% 1/2W F
 △R578 1-219-193-11 FUSIBLE 220 5% 1/2W F
 △R579 1-219-185-11 FUSIBLE 47 5% 1/2W F
 △R582 1-219-185-11 FUSIBLE 47 5% 1/2W F
 R584 1-219-392-11 RES, WIREWOUND
 R585 1-249-951-11 CARBON 15K 5% 1/4W
 R586 1-259-191-21 CARBON 10K 5% 1/4W
 △R587 1-247-717-11 CARBON 2.2K 5% 1/4W F
 △R588 1-247-717-11 CARBON 2.2K 5% 1/4W F

< VARIABLE RESISTOR >

RT551 1-224-490-11 RES, ADJ, METAL FILM 4.7K

* 1-655-083-11 MEDAMA BOARD

< IC >

IC906 8-749-923-43 IC GP1U57XB

* 1-655-084-11 MUT LED BOARD

< CONNECTOR >

* CN316 1-564-506-11 PLUG, CONNECTOR 3P

< DIODE >

D302 8-719-301-49 LED SEL2810A (MUTING)

* 1-655-090-11 OUT LET BOARD

* 1-533-185-11 HOLDER, FUSE

< CAPACITOR >

△C802 1-161-742-00 CERAMIC 0.0022uF 20% 400V

< CONNECTOR >

CN100 1-564-321-00 PIN, CONNECTOR 2P
 * CN101 1-564-321-21 PIN, CONNECTOR 2P

The components identified by mark △ or dotted line with mark △ are critical for safety. Replace only with part number specified.

OUT LET**PRE PS****PRO**

Ref. No.	Part No.	Description	Remark
CN102	1-580-629-21	PIN, CONNECTOR 2P	

< FUSE >

△F802	1-532-299-00	FUSE, TIME-LAG (T5A/250V) (FA7ES)	
△F802	1-532-350-00	FUSE, TIME-LAG (T4A/250V) (FA5ES)	

*	1-655-077-11	PRE PS BOARD (FA5ES)	
*	1-655-077-21	PRE PS BOARD (FA7ES)	

< CAPACITOR >

C801	1-124-922-11	ELECT	1000uF	20%	63V (FA5ES)
C801	1-110-397-11	ELECT	1000uF	20%	63V (FA7ES)
C802	1-124-922-11	ELECT	1000uF	20%	63V (FA5ES)
C802	1-110-397-11	ELECT	1000uF	20%	63V (FA7ES)
C808	1-126-066-11	ELECT	470uF	20%	63V (FA5ES)
C808	1-110-397-11	ELECT	1000uF	20%	63V (FA7ES)
C809	1-110-393-11	ELECT	100uF	20%	63V
C851	1-124-922-11	ELECT	1000uF	20%	63V (FA5ES)
C851	1-110-397-11	ELECT	1000uF	20%	63V (FA7ES)
C852	1-124-922-11	ELECT	1000uF	20%	63V (FA5ES)
C852	1-110-397-11	ELECT	1000uF	20%	63V (FA7ES)
C858	1-126-066-11	ELECT	470uF	20%	63V (FA5ES)
C858	1-110-397-11	ELECT	1000uF	20%	63V (FA7ES)
C859	1-110-393-11	ELECT	100uF	20%	63V

< CONNECTOR >

CN801	1-691-768-11	PLUG (MICRO CONNECTOR) 6P	
CN802	1-564-510-11	PLUG (MICRO CONNECTOR) 6P	
* CN803	1-564-506-11	PLUG, CONNECTOR 3P	
* CN804	1-564-506-11	PLUG, CONNECTOR 3P (FA7ES)	

< DIODE >

D801	8-719-000-93	DIODE	UZL-7H1
D802	8-719-000-93	DIODE	UZL-7H1
D851	8-719-000-93	DIODE	UZL-7H1
D852	8-719-000-93	DIODE	UZL-7H1

< TRANSISTOR >

Q806	8-729-030-18	TRANSISTOR	2SD2525
Q807	8-729-281-54	TRANSISTOR	2SC1815-BL
Q808	8-729-202-67	TRANSISTOR	2SK246-GR3
Q809	8-729-030-18	TRANSISTOR	2SD2525
Q810	8-729-030-18	TRANSISTOR	2SD2525
Q856	8-729-030-19	TRANSISTOR	2SB1640
Q857	8-729-201-53	TRANSISTOR	2SA1015-GR
Q858	8-729-202-67	TRANSISTOR	2SK246-GR3
Q859	8-729-030-19	TRANSISTOR	2SB1640
Q860	8-729-030-19	TRANSISTOR	2SB1640

Ref. No.	Part No.	Description	Remark
< RESISTOR >			

R818	1-259-171-21	CARBON	1.5K 5% 1/4W
R819	1-249-931-11	CARBON	2.2K 5% 1/4W
△R820	1-219-189-11	FUSIBLE	100 5% 1/2W F (FA5ES)
△R820	1-219-022-11	FUSIBLE	100 5% 1/2W F (FA7ES)
△R821	1-219-189-11	FUSIBLE	100 5% 1/2W F (FA5ES)
△R821	1-219-022-11	FUSIBLE	100 5% 1/2W F (FA7ES)
△R822	1-219-189-11	FUSIBLE	100 5% 1/2W F (FA5ES)
△R822	1-219-022-11	FUSIBLE	100 5% 1/2W F (FA7ES)
△R823	1-219-189-11	FUSIBLE	100 5% 1/2W F (FA5ES)
△R823	1-219-022-11	FUSIBLE	100 5% 1/2W F (FA7ES)
R868	1-259-171-21	CARBON	1.5K 5% 1/4W
R869	1-249-931-11	CARBON	2.2K 5% 1/4W
△R870	1-219-189-11	FUSIBLE	100 5% 1/2W F (FA5ES)
△R870	1-219-022-11	FUSIBLE	100 5% 1/2W F (FA7ES)
△R871	1-219-189-11	FUSIBLE	100 5% 1/2W F (FA5ES)
△R871	1-219-022-11	FUSIBLE	100 5% 1/2W F (FA7ES)
△R872	1-219-189-11	FUSIBLE	100 5% 1/2W F (FA5ES)
△R872	1-219-022-11	FUSIBLE	100 5% 1/2W F (FA7ES)
△R873	1-219-189-11	FUSIBLE	100 5% 1/2W F (FA5ES)
△R873	1-219-022-11	FUSIBLE	100 5% 1/2W F (FA7ES)

< TRANSFORMER >

T801	1-427-648-11	TRANSFORMER (CHOKE)	
------	--------------	---------------------	--

*	A-4378-503-A	PRO BOARD, COMPLETE (FA5ES)	
*	A-4378-516-A	PRO BOARD, COMPLETE (FA7ES)	

< CAPACITOR >

C603	1-136-157-00	FILM	0.022uF 5% 50V
C604	1-124-120-11	ELECT	220uF 20% 25V
C605	1-124-910-11	ELECT	47uF 20% 50V
C607	1-136-157-00	FILM	0.022uF 5% 50V
C608	1-126-058-11	ELECT	4.7uF 20% 63V
C609	1-124-918-11	ELECT	47uF 20% 63V
C610	1-126-058-11	ELECT	4.7uF 20% 63V
C611	1-136-157-00	FILM	0.022uF 5% 50V
C612	1-126-059-11	ELECT	10uF 20% 63V
C620	1-130-973-00	FILM	0.022uF 2% 100V
C670	1-130-973-00	FILM	0.022uF 2% 100V

< CONNECTOR >

CN601	1-766-897-11	PIN, CONNECTOR (PC BOARD) 4P	
CN602	1-691-766-11	PLUG (MICRO CONNECTOR) 4P	
* CN603	1-564-506-11	PLUG, CONNECTOR 3P	
* CN604	1-564-506-11	PLUG, CONNECTOR 3P	
CN605	1-564-505-11	PLUG, CONNECTOR 2P	

The components identified by mark △ or dotted line with mark △ are critical for safety. Replace only with part number specified.

PRO

PRO LED

PS

Ref.No.	Part No.	Description	Remark
* CN606	1-564-506-11	PLUG, CONNECTOR 3P	
* CN607	1-564-506-11	PLUG, CONNECTOR 3P	
* CN608	1-564-506-11	PLUG, CONNECTOR 3P	
CN609	1-691-766-21	PLUG (MICRO CONNECTOR) 4P	
CN610	1-766-897-21	PIN, CONNECTOR (PC BOARD) 4P	
< DIODE >			
D601	8-719-987-63	DIODE 1N4148M	
D602	8-719-310-60	LED SEL1510C-C	
D603	8-719-987-63	DIODE 1N4148M	
< IC >			
IC601	8-759-111-68	IC uPC1237HA	
< COIL >			
L601	1-422-009-21	COIL, AIR-CORE	
L651	1-422-009-21	COIL, AIR-CORE	
< TRANSISTOR >			
Q601	8-729-281-54	TRANSISTOR 2SC1815-BL	
Q602	8-729-030-18	TRANSISTOR 2SD2525	
Q603	8-729-201-53	TRANSISTOR 2SA1015-GR	
Q604	8-729-201-53	TRANSISTOR 2SA1015-GR	
Q605	8-729-281-54	TRANSISTOR 2SC1815-BL	
Q606	8-729-030-18	TRANSISTOR 2SD2525	
< RESISTOR >			
R604	1-259-223-21	CARBON 220K 5% 1/4W	
R606	1-259-191-21	CARBON 10K 5% 1/4W	
R607	1-249-885-11	CARBON 27 5% 1/4W	
R608	1-249-725-11	CARBON 150K 5% 1/4W	
R609	1-249-951-11	CARBON 15K 5% 1/4W	
R610	1-260-322-11	CARBON 330 5% 1/2W	
R612	1-249-939-11	CARBON 4.7K 5% 1/4W	
R613	1-259-191-21	CARBON 10K 5% 1/4W	
R614	1-259-207-21	CARBON 47K 5% 1/4W	
R615	1-249-955-11	CARBON 22K 5% 1/4W	
R616	1-259-207-21	CARBON 47K 5% 1/4W	
R617	1-249-955-11	CARBON 22K 5% 1/4W	
R620	1-249-733-11	CARBON 330K 5% 1/4W	
R621	1-249-754-11	CARBON 10 5% 1/2W	
R622	1-249-798-11	CARBON 680 5% 1/2W	
△R624	1-217-989-11	FUSIBLE 4.7 5% 1/2W F (FA5ES)	
△R624	1-260-072-11	FUSIBLE 4.7 5% 1/2W F (FA7ES)	
△R625	1-217-989-11	FUSIBLE 4.7 5% 1/2W F (FA5ES)	
△R625	1-260-072-11	FUSIBLE 4.7 5% 1/2W F (FA7ES)	
R626	1-259-167-21	CARBON 1K 5% 1/4W	
R628	1-260-322-11	CARBON 330 5% 1/2W	

Ref.No.	Part No.	Description	Remark
R629	1-260-322-11	CARBON 330 5% 1/2W	
R670	1-249-733-11	CARBON 330K 5% 1/4W	
R671	1-249-754-11	CARBON 10 5% 1/2W	
R672	1-249-798-11	CARBON 680 5% 1/2W	
△R674	1-217-989-11	FUSIBLE 4.7 5% 1/2W F (FA5ES)	
△R674	1-260-072-11	FUSIBLE 4.7 5% 1/2W F (FA7ES)	
△R675	1-217-989-11	FUSIBLE 4.7 5% 1/2W F (FA5ES)	
△R675	1-260-072-11	FUSIBLE 4.7 5% 1/2W F (FA7ES)	
R677	1-249-794-11	CARBON 470 5% 1/2W	
R678	1-249-794-11	CARBON 470 5% 1/2W	
< RELAY >			
RY601	1-755-061-11	RELAY	
RY602	1-515-676-11	RELAY	

*	1-655-085-11	PRO LED BOARD	

< CONNECTOR >			
* CN806	1-564-506-11	PLUG, CONNECTOR 3P	
< DIODE >			
D801	8-719-313-40	LED SEL1516W (POWER)	
< RESISTOR >			
R801	1-249-407-11	CARBON 150 5% 1/4W	

*	1-655-078-11	PS BOARD (FA5ES)	
*	1-655-078-21	PS BOARD (FA7ES)	

*	3-555-872-21	SPACER	
< TERMINAL >			
* BP701	1-535-117-00	TERMINAL	
* BP702	1-535-117-00	TERMINAL	
* BP703	1-535-115-00	TERMINAL	
* BP704	1-535-115-00	TERMINAL	
< CAPACITOR >			
C703	1-124-920-11	ELECT 330uF 20% 63V	
C704	1-124-920-11	ELECT 330uF 20% 63V	
C705	1-124-791-11	ELECT 1.0uF 20% 100V	
C706	1-124-920-11	ELECT 330uF 20% 63V	
C707	1-136-880-11	FILM 2.2uF 10% 160V	
C708	1-124-920-11	ELECT 330uF 20% 63V (FA7ES)	

The components identified by mark △ or dotted line with mark △ are critical for safety. Replace only with part number specified.

PS
PS JUMPER
REC OUT
SP-TM
TONE. CONTROL

Ref.No. Part No. Description Remark

< CONNECTOR >

- * CN701 1-564-241-11 PIN, CONNECTOR (B4P-VH) 4P
- CN703 1-691-766-31 PLUG (MICRO CONNECTOR) 4P
- CN705 1-691-768-11 PLUG (MICRO CONNECTOR) 6P
- * CN706 1-564-506-11 PLUG, CONNECTOR 3P

< DIODE >

- D701 8-719-210-25 DIODE C25P20F
- D702 8-719-210-25 DIODE C25P20F
- D703 8-719-210-26 DIODE C25P20FR
- D704 8-719-210-26 DIODE C25P20FR
- D705 8-719-200-82 DIODE 11ES2

- D706 8-719-200-82 DIODE 11ES2
- D707 8-719-200-82 DIODE 11ES2
- D708 8-719-200-82 DIODE 11ES2
- D709 8-719-200-82 DIODE 11ES2
- D710 8-719-200-82 DIODE 11ES2

- D711 8-719-200-82 DIODE 11ES2

< PLATE GROUND >

- * EPT701 4-916-791-01 PLATE, GROUND, 5P
- * EPT702 3-346-266-21 PLATE, GROUND
- * EPT703 3-346-266-21 PLATE, GROUND
- * EPT704 3-346-266-21 PLATE, GROUND
- * EPT705 3-346-266-21 PLATE, GROUND

< RESISTOR >

- AR701 1-219-165-11 FUSIBLE 1 5% 1/2W F
- *****
- * 1-655-076-11 PS JUMPER BOARD (FA5ES)
- * 1-655-076-21 PS JUMPER BOARD (FA7ES)
- *****

- * 1-655-082-11 REC OUT BOARD
- *****

< CONNECTOR >

- * CN315 1-564-506-11 PLUG, CONNECTOR 3P

< SWITCH >

- S302 1-762-186-11 SWITCH, TOGGLE (REC OUT)
- *****
- * 1-655-072-11 SP-TM BOARD (FA5ES)
- * 1-655-072-21 SP-TM BOARD (FA7ES)
- *****

Ref.No. Part No. Description Remark

< TERMINAL >

- TM801 1-537-930-11 TERMINAL BOARD (SP) 4P (FA5ES)
- TM801 1-537-931-11 TERMINAL BOARD (SP) 4P (FA7ES)
- TM802 1-537-930-11 TERMINAL BOARD (SP) 4P (FA5ES)
- TM802 1-537-931-11 TERMINAL BOARD (SP) 4P (FA7ES)

- * A-4371-831-A TONE CONTROL BOARD, COMPLET
- *****

- * 1-535-730-21 LEAD, JUMPER (OFC)

< CAPACITOR >

- | | | | | |
|------|----------------------|----------|-----|------|
| C301 | 1-130-475-00 MYLAR | 0.0022uF | 5% | 50V |
| C302 | 1-130-483-00 MYLAR | 0.01uF | 5% | 50V |
| C303 | 1-130-485-00 MYLAR | 0.015uF | 5% | 50V |
| C304 | 1-136-165-00 FILM | 0.1uF | 5% | 50V |
| C306 | 1-136-165-00 FILM | 0.1uF | 5% | 50V |
| | | | | |
| C307 | 1-136-165-00 FILM | 0.1uF | 5% | 50V |
| C351 | 1-130-475-00 MYLAR | 0.0022uF | 5% | 50V |
| C352 | 1-130-483-00 MYLAR | 0.01uF | 5% | 50V |
| C353 | 1-130-485-00 MYLAR | 0.015uF | 5% | 50V |
| C354 | 1-136-165-00 FILM | 0.1uF | 5% | 50V |
| | | | | |
| C805 | 1-106-343-00 MYLAR | 1000PF | 5% | 200V |
| C806 | 1-106-343-00 MYLAR | 1000PF | 5% | 200V |
| C901 | 1-126-376-11 ELECT | 470uF | 20% | 25V |
| C902 | 1-164-159-11 CERAMIC | 0.1uF | | 50V |
| C903 | 1-126-023-11 ELECT | 100uF | 20% | 16V |
| | | | | |
| C904 | 1-162-207-31 CERAMIC | 22PF | 5% | 50V |
| C905 | 1-162-207-31 CERAMIC | 22PF | 5% | 50V |
| C906 | 1-162-282-31 CERAMIC | 100PF | 10% | 50V |
| C907 | 1-164-159-11 CERAMIC | 0.1uF | | 50V |
| C908 | 1-164-159-11 CERAMIC | 0.1uF | | 50V |
| | | | | |
| C909 | 1-136-165-00 FILM | 0.1uF | 5% | 50V |

< CONNECTOR >

- * CN301 1-564-506-11 PLUG, CONNECTOR 3P
- CN302 1-691-766-41 PLUG (MICRO CONNECTOR) 4P
- CN303 1-691-770-11 PLUG (MICRO CONNECTOR) 8P
- * CN310 1-564-506-11 PLUG, CONNECTOR 3P
- * CN313 1-564-506-11 PLUG, CONNECTOR 3P

- * CN314 1-564-506-11 PLUG, CONNECTOR 3P
- CN352 1-691-766-31 PLUG (MICRO CONNECTOR) 4P
- * CN807 1-564-506-11 PLUG, CONNECTOR 3P
- CN901 1-564-320-00 PIN, CONNECTOR (B2P-VH) 2P
- CN902 1-564-505-11 PLUG, CONNECTOR 2P

- CN903 1-691-772-11 PLUG (MICRO CONNECTOR) 10P
- * CN905 1-564-506-11 PLUG, CONNECTOR 3P
- * CN906 1-564-506-11 PLUG, CONNECTOR 3P

The components identified by mark A or dotted line with mark A are critical for safety. Replace only with part number specified.

TONE. CONTROL

VOL

Ref. No.	Part No.	Description	Remark
CN907	1-691-770-11	PLUG (MICRO CONNECTOR) 8P	
< DIODE >			
D901	8-719-200-02	DIODE 10E2	
D902	8-719-200-02	DIODE 10E2	
D903	8-719-200-02	DIODE 10E2	
D904	8-719-200-02	DIODE 10E2	
D905	8-719-987-63	DIODE 1N4148M	
D906	8-719-987-63	DIODE 1N4148M	
D907	8-719-987-63	DIODE 1N4148M	
D908	8-719-987-63	DIODE 1N4148M	
D909	8-719-987-63	DIODE 1N4148M	
D910	8-719-987-63	DIODE 1N4148M	
D911	8-719-987-63	DIODE 1N4148M	
D912	8-719-987-63	DIODE 1N4148M	
D913	8-719-200-02	DIODE 10E2	
< IC >			
IC901	8-759-325-18	IC TMP47C200BN-H327	
IC902	8-759-635-63	IC M51943BSL	
IC903	8-759-188-67	IC X24C01P-S	
IC904	8-759-962-08	IC BA6208	
IC905	8-759-231-53	IC TA7805S	
< TRANSISTOR >			
Q301	8-729-281-54	TRANSISTOR 2SC1815-BL	
Q901	8-729-900-63	TRANSISTOR DTA124ES	
Q902	8-729-900-63	TRANSISTOR DTA124ES	
Q903	8-729-900-63	TRANSISTOR DTA124ES	
Q904	8-729-900-63	TRANSISTOR DTA124ES	
Q905	8-729-900-63	TRANSISTOR DTA124ES	
Q906	8-729-900-63	TRANSISTOR DTA124ES	
Q907	8-729-900-63	TRANSISTOR DTA124ES	
Q908	8-729-900-63	TRANSISTOR DTA124ES	
< RESISTOR >			
R301	1-247-721-11	CARBON 4.7K 5% 1/4W	
R302	1-249-556-11	CARBON 1.5K 5% 1/4W	
R303	1-259-502-11	CARBON 4.7M 5% 1/4W	
R304	1-259-502-11	CARBON 4.7M 5% 1/4W	
R305	1-249-462-11	CARBON 22K 5% 1/4W	
R306	1-247-721-11	CARBON 4.7K 5% 1/4W	
R307	1-249-425-11	CARBON 4.7K 5% 1/4W	
R311	1-249-425-11	CARBON 4.7K 5% 1/4W	
R351	1-247-721-11	CARBON 4.7K 5% 1/4W	
R352	1-249-556-11	CARBON 1.5K 5% 1/4W	
R353	1-259-502-11	CARBON 4.7M 5% 1/4W	
R354	1-259-502-11	CARBON 4.7M 5% 1/4W	
R355	1-249-462-11	CARBON 22K 5% 1/4W	

Ref. No.	Part No.	Description	Remark
R356	1-247-721-11	CARBON 4.7K 5% 1/4W	
R824	1-247-747-11	CARBON 470 5% 1/2W	
R825	1-247-747-11	CARBON 470 5% 1/2W	
R901	1-249-433-11	CARBON 22K 5% 1/4W	
R902	1-249-433-11	CARBON 22K 5% 1/4W	
R903	1-249-433-11	CARBON 22K 5% 1/4W	
R904	1-249-433-11	CARBON 22K 5% 1/4W	
R905	1-249-433-11	CARBON 22K 5% 1/4W	
R906	1-249-433-11	CARBON 22K 5% 1/4W	
R907	1-249-425-11	CARBON 4.7K 5% 1/4W	
R908	1-249-425-11	CARBON 4.7K 5% 1/4W	
R909	1-249-425-11	CARBON 4.7K 5% 1/4W	
R910	1-249-429-11	CARBON 10K 5% 1/4W	
R911	1-249-429-11	CARBON 10K 5% 1/4W	
R913	1-249-433-11	CARBON 22K 5% 1/4W	
R914	1-249-433-11	CARBON 22K 5% 1/4W	
R915	1-249-429-11	CARBON 10K 5% 1/4W	
R916	1-247-807-31	CARBON 100 5% 1/4W	
R917	1-247-807-31	CARBON 100 5% 1/4W	
R918	1-247-807-31	CARBON 100 5% 1/4W	
R919	1-247-807-31	CARBON 100 5% 1/4W	
R920	1-247-807-31	CARBON 100 5% 1/4W	
R921	1-247-807-31	CARBON 100 5% 1/4W	
R922	1-247-807-31	CARBON 100 5% 1/4W	
R923	1-249-425-11	CARBON 4.7K 5% 1/4W	
R924	1-249-413-11	CARBON 470 5% 1/4W	
△R925	1-217-981-11	FUSIBLE 2.2 5% 1/2W F	
< VARIABLE RESISTOR >			
RV301	1-223-789-11	RES. VAR. CARBON 250K/250K (BALANCE)	
RV302	1-223-768-11	RES. VAR. CARBON 250K/250K (TREBLE)	
RV303	1-223-767-11	RES. VAR. CARBON 900K/900K (BASS)	
< SWITCH >			
S301	1-762-203-11	SWITCH, PUSH (1 KEY) (MUTING)	
S801	1-762-184-11	SWITCH, ROTARY (SPEAKERS)	
S901	1-762-183-11	SWITCH, ROTARY (INPUT SELECTOR)	
< VIBRATOR >			
X901	1-579-223-11	OSCILLATOR, CERAMIC (8.19MHz)	

*	1-655-087-11	VOL BOARD	

< CAPACITOR >			
C308	1-136-165-00	FILM 0.1uF 5% 50V	
C309	1-136-165-00	FILM 0.1uF 5% 50V	
C310	1-136-165-00	FILM 0.1uF 5% 50V	

The components identified by mark △ or dotted line with mark △ are critical for safety. Replace only with part number specified.

Ref. No.	Part No.	Description	Remark
< CONNECTOR >			
CN305	1-691-766-41	PLUG (MICRO CONNECTOR) 4P	
CN306	1-691-770-11	PLUG (MICRO CONNECTOR) 8P	
CN308	1-691-766-21	PLUG (MICRO CONNECTOR) 4P	
CN309	1-691-766-11	PLUG (MICRO CONNECTOR) 4P	
CN355	1-691-766-31	PLUG (MICRO CONNECTOR) 4P	
< DIODE >			
D304	8-719-987-63	DIODE 1N4148M	
< TRANSISTOR >			
Q302	8-729-184-53	TRANSISTOR 2SC1845-EA	
< RESISTOR >			
R309	1-249-469-11	CARBON 100K 5% 1/4W	
R312	1-249-677-11	CARBON 1.5K 5% 1/2W	
R313	1-249-677-11	CARBON 1.5K 5% 1/2W	
R314	1-247-725-11	CARBON 10K 5% 1/4W	
R315	1-249-465-11	CARBON 47K 5% 1/4W	
R359	1-249-469-11	CARBON 100K 5% 1/4W	
< VARIABLE RESISTOR >			
RV304	1-223-765-11	RES. VAR. CARBON 120K/120K (ATTENUATOR) (FA5ES)	
RV304	1-223-765-21	RES. VAR. CARBON 120K/120K (ATTENUATOR) (FA7ES)	
< RELAY >			
RY301	1-755-062-11	RELAY	
< SWITCH >			
S303	1-762-190-11	SWITCH, PUSH (1 KEY) (SURCE DIRECT)	

MISCELLANEOUS			

* 160	1-535-691-21	TERMINAL (FA5ES)	
* 160	1-535-691-31	TERMINAL (FA7ES)	
161	1-506-113-00	SHORT PLUG	
C701	1-104-902-11	CAP. ELECT 15000uF (FA7ES)	
C701	1-107-845-12	CAP. ELECT 12000uF (FA5ES)	
C702	1-104-902-11	CAP. ELECT 15000uF (FA7ES)	
C702	1-107-845-12	CAP. ELECT 12000uF (FA5ES)	
△CNS1	1-575-953-11	CORD. POWER	
△F802	1-532-299-00	FUSE, TIME-LAG (T5A/250V) (FA7ES)	
△F802	1-532-350-00	FUSE, TIME-LAG (T4A/250V) (FA5ES)	
Q513	8-729-203-45	TRANSISTOR 2SC3423-0	

Ref. No.	Part No.	Description	Remark
Q515	8-729-018-19	TRANSISTOR 2SK2013-Y	
Q516	8-729-018-21	TRANSISTOR 2SJ313-Y	
Q518	8-729-018-11	TRANSISTOR 2SK1530A-Y (FA7ES)	
Q518	8-729-030-14	TRANSISTOR 2SK1530B-Y (FA5ES)	
Q520	8-729-018-13	TRANSISTOR 2SJ201A-Y (FA7ES)	
Q520	8-729-030-15	TRANSISTOR 2SJ201B-Y (FA5ES)	
Q563	8-729-203-45	TRANSISTOR 2SC3423-0	
Q565	8-729-018-19	TRANSISTOR 2SK2013-Y	
Q566	8-729-018-21	TRANSISTOR 2SJ313-Y	
Q568	8-729-018-11	TRANSISTOR 2SK1530A-Y (FA7ES)	
Q568	8-729-030-14	TRANSISTOR 2SK1530B-Y (FA5ES)	
Q570	8-729-018-13	TRANSISTOR 2SJ201A-Y (FA7ES)	
Q570	8-729-030-15	TRANSISTOR 2SJ201B-Y (FA5ES)	
S001	1-762-185-11	SWITCH, ROTARY SLIDE (REC OUT SELECTOR)	

- △T1 1-429-111-11 TRANSFORMER, POWER (FA5ES)
- △T1 1-429-112-11 TRANSFORMER, POWER (FA7ES)

ACCESSORIES & PACKING MATERIALS

- 1-465-801-11 REMOTE COMMANDER (RM-S703)
- 3-707-584-21 LID, BATTERY (for RM-S703)
- 3-800-210-11 MANUAL, INSTRUCTION (ENGLISH, FRENCH, SPANISH, PORTUGUESE)
- 3-800-210-21 MANUAL, INSTRUCTION (GERMAN, DUTCH, SWEDISH, ITALIAN)

- * 4-970-079-01 CUSHION
- * 4-977-437-01 INDIVIDUAL CARTON (FA5ES)
- * 4-977-438-01 INDIVIDUAL CARTON (FA7ES)

HARDWARE LIST

- #1 7-682-148-15 SCREW, TR
- #2 7-682-246-09 SCREW +K 3X5
- #3 7-682-548-09 SCREW (3X8)
- #4 7-682-564-09 SCREW +B 4X14
- #5 7-682-565-09 SCREW +B 4X16 (FA5ES)
- #5 7-682-566-09 SCREW +B 4X20 (FA7ES)
- #6 7-684-024-04 N 4, TYPE 2

The components identified by mark △ or dotted line with mark △ are critical for safety. Replace only with part number specified.