

TA-FA3ES

SERVICE MANUAL

AEP Model



SPECIFICATIONS

System

Power Amplifier: Pure-complementary SEPP MOS
FET power amplifier with all stages directly coupled
Preamplifier: Low-noise, high-gain equalizer amplifier
Power section: Large-capacity power supply advanced
STD

Rated output	4 ohms, 100W + 100W (DIN 0.7%) 8 ohms, 70W + 70W (DIN 0.7%)
Speakers impedance	4 to 16 ohms
Output bandwidth (8 ohms)	10Hz to 100kHz (at 40W output, and high-frequency distortion rate of 0.08%)
Dynamic headroom	at 4 ohms: 2dB at 8 ohms: 1.2dB
Total harmonic distortion	0.008% (at 8 ohms, 10W output)
Damping factor	100 (8 ohms, 1kHz)
Intermodulation (IM) distortion (60Hz:7kHz=4:1)	0.008% (8 ohms)
Throughrate	125 V/ μ sec, 250 V/ μ sec (Inside)
Residual noise	Less than 100 μ V (network A)
Equalizer deviation	PHONO MM: 20Hz to 20kHz, ± 0.2 dB
Frequency response	TUNER, CD, AUX, TAPE 1, 2: 5Hz to 100kHz ± 3 dB
S/N	PHONO MC: 77dB (A Fil, 0.5mV) MM: 95dB (A Fil, 5mV) TUNER, CD, AUX, TAPE1, 2: 105dB

Inputs

Input sensitivity and impedance	PHONO MC: 0.17mV, 100ohms MM: 2.5mV, 50kilohms TUNER, CD, AUX, TAPE 1, 2: 150mV, 20kilohms
Maximum input capability (1 kHz)	PHONO MC: 9mV MM: 150mV

Outputs

Output level / impedance	REC OUT 1, 2: 150mV, 1kilohms PHONES: 10 mW (at 8ohms)
Tone controls	BASS (100Hz): ± 7 dB TREBLE (10kHz): ± 6 dB

General

Power requirements	220 - 230 V AC, 50/60Hz
Power consumption	200W
Dimensions (approx.) (w/h/d)	430 \times 135 \times 375mm (17 \times 5 $\frac{3}{8}$ \times 14 $\frac{7}{8}$ inches) incl. projecting parts and controls
Mass (approx.)	10.0kg (22lb 1oz)
Supplied accessories	Remote commander (remote) RM-S702 (1) Sony batteries SUM-3(NS) (2)

Design and specifications are subject to change without notice.



INTEGRATED STEREO AMPLIFIER
SONY®



TABLE OF CONTENTS

<u>Section</u>	<u>Title</u>	<u>Page</u>
	Specifications	1
1.	GENERAL	
	Location of Controls	3
2.	ELECTRICAL ADJUSTMENT	4
3.	DIAGRAMS	
3-1.	Circuit Boards Location	5
3-2.	Schematic Diagram – Main Section –	6
3-3.	Printed Wiring Boards – Main Section –	9
3-4.	Printed Wiring Boards – Panel Section – ...	14
3-5.	Schematic Diagram – Panel Section –	17
4.	EXPLODED VIEWS	20
5.	ELECTRICAL PARTS LIST	23

SAFETY-RELATED COMPONENT WARNING!!

COMPONENTS IDENTIFIED BY MARK  OR DOTTED LINE WITH MARK  ON THE SCHEMATIC DIAGRAMS AND IN THE PARTS LIST ARE CRITICAL TO SAFE OPERATION. REPLACE THESE COMPONENTS WITH SONY PARTS WHOSE PART NUMBERS APPEAR AS SHOWN IN THIS MANUAL OR IN SUPPLEMENTS PUBLISHED BY SONY.

SECTION 1 GENERAL

• Location of Controls

Front Panel Descriptions

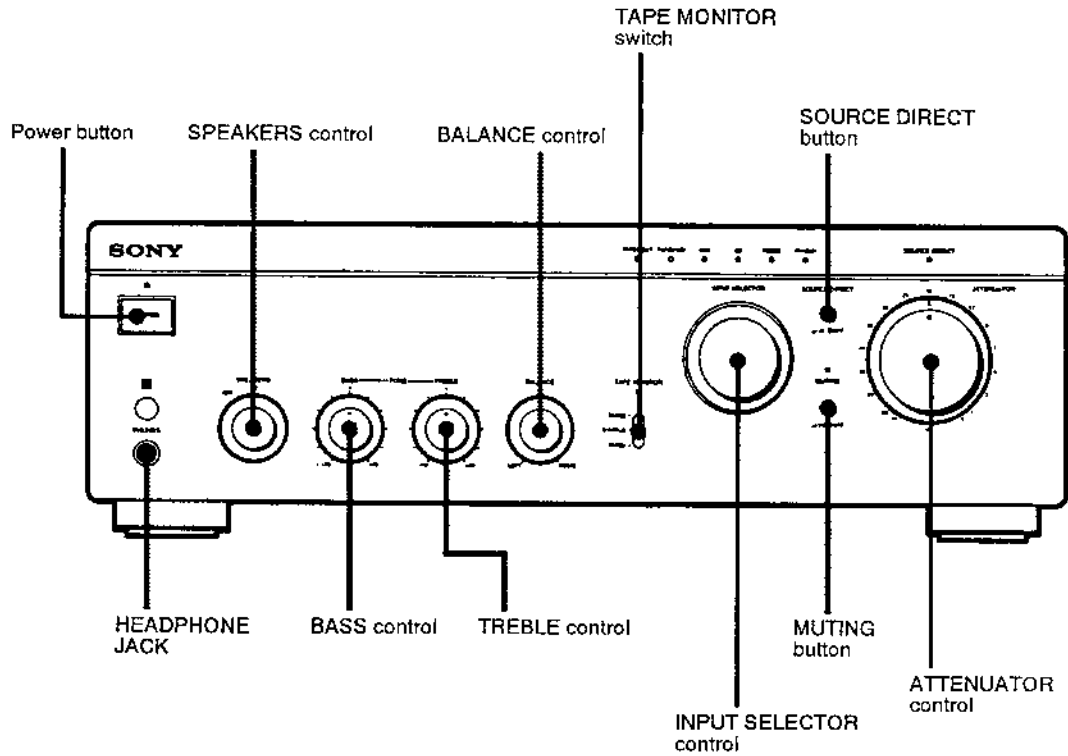

Rear Panel Descriptions

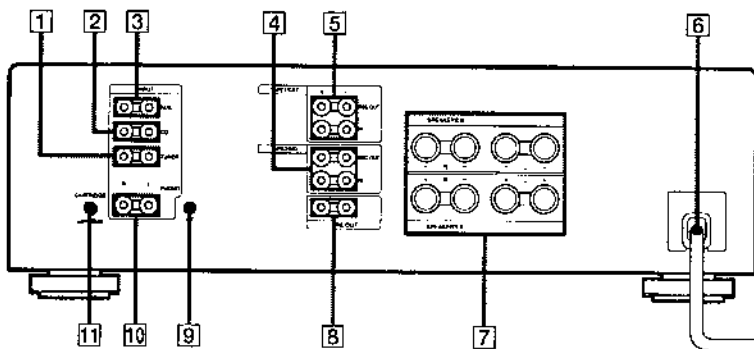

- 1 TUNER
- 2 CD
- 3 AUX
- 4 TAPE2/MD
- 5 TAPE1/DAT
- 6 Mains lead
- 7 SPEAKERS A/B
- 8 PRE OUT
- 9 ♂ (earth)
- 10 PHONO
- 11 CARTRIDGE MC/MM

SECTION 2 ELECTRICAL ADJUSTMENT

Bias Adjustment

1. Rotate fully the bias adjusting semi-fixed resistors (RV501, RV601) to the MIN position (counterclockwise).
2. Connect a digital voltmeter to the TP500 and TP600.

	1 pin	3 pin
TP500	-	+
TP600	+	-

3. Set the slidack to 0 V, and press the POWER button (ON) on the set.
4. Raise gradually the slidack voltage up to the rated voltage (230 V).
5. At this time, confirm that the SP relay is turned on (it will click), and at the same time, the LED on the POWER button changes from red to green.
6. Adjust the RV501 and RV601 so that a reading of digital voltmeter is $33\text{ mV} \pm 2\text{ mV}$.
7. Return the slidack to 0 V, and press the POWER button (OFF) on the set.

Adjustment Location:

MAIN BOARD (COMPONENT SIDE)

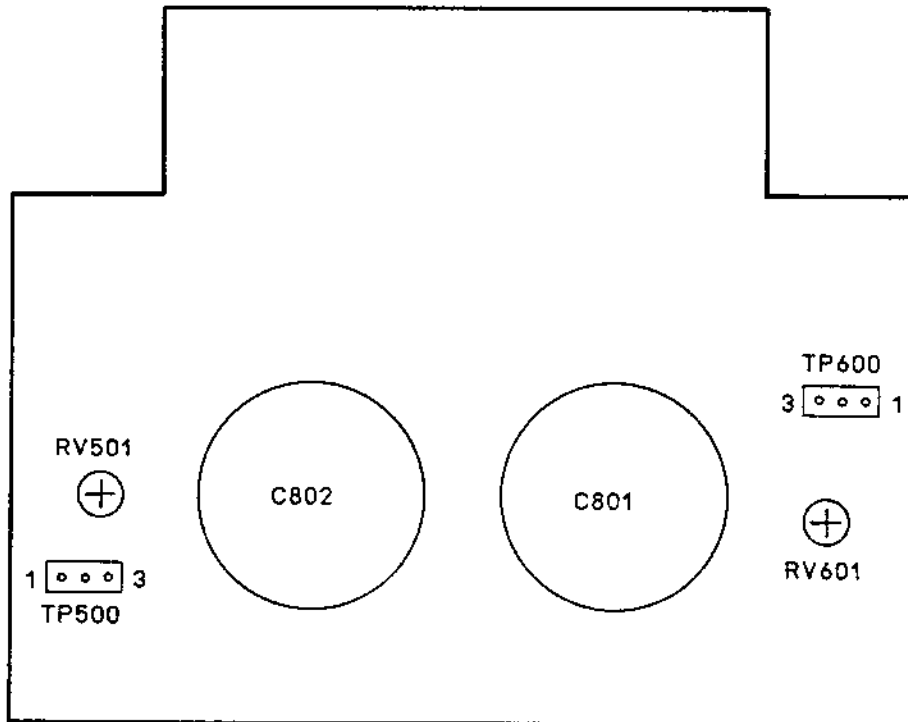

SECTION 3 DIAGRAMS

3-1. CIRCUIT BOARDS LOCATION

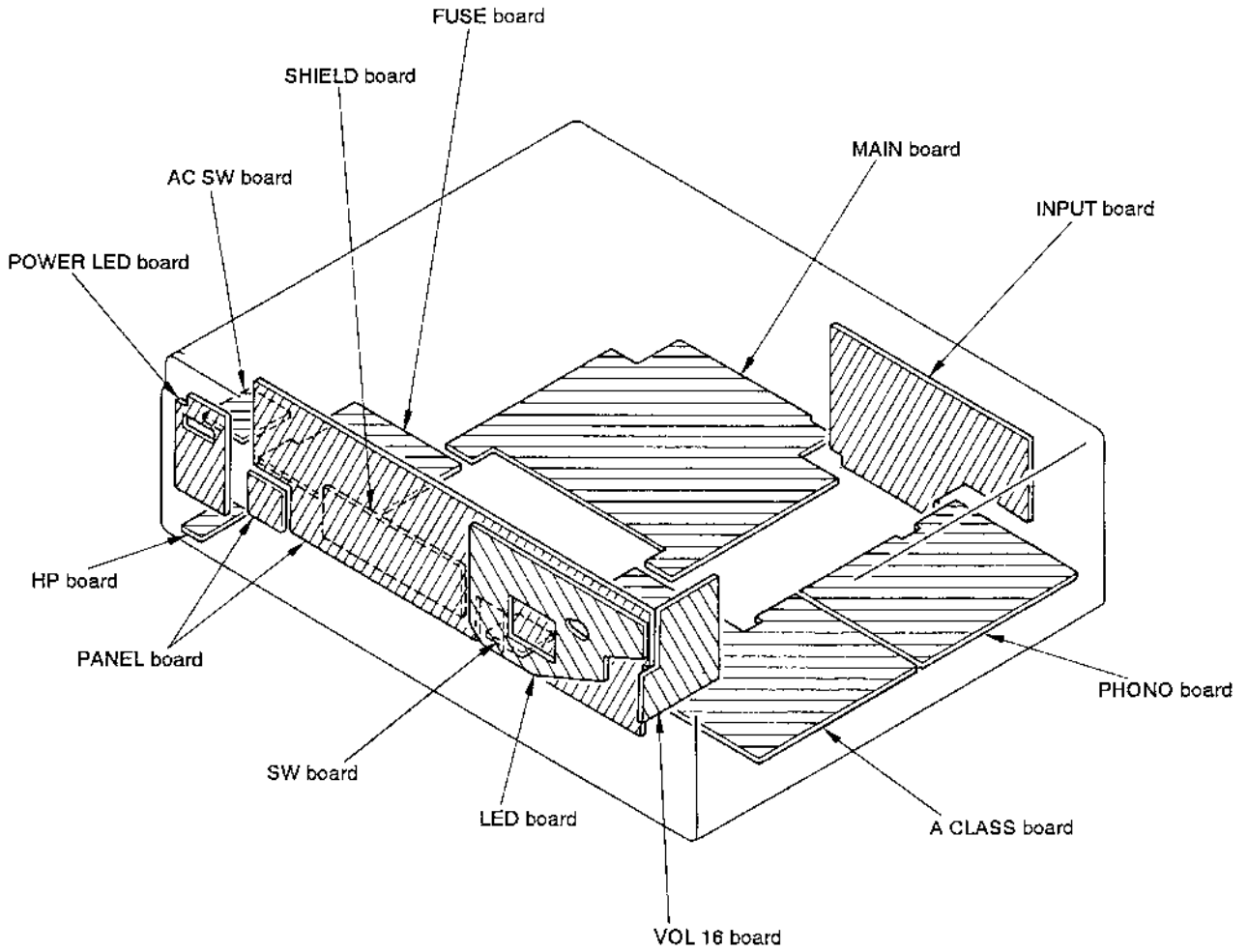

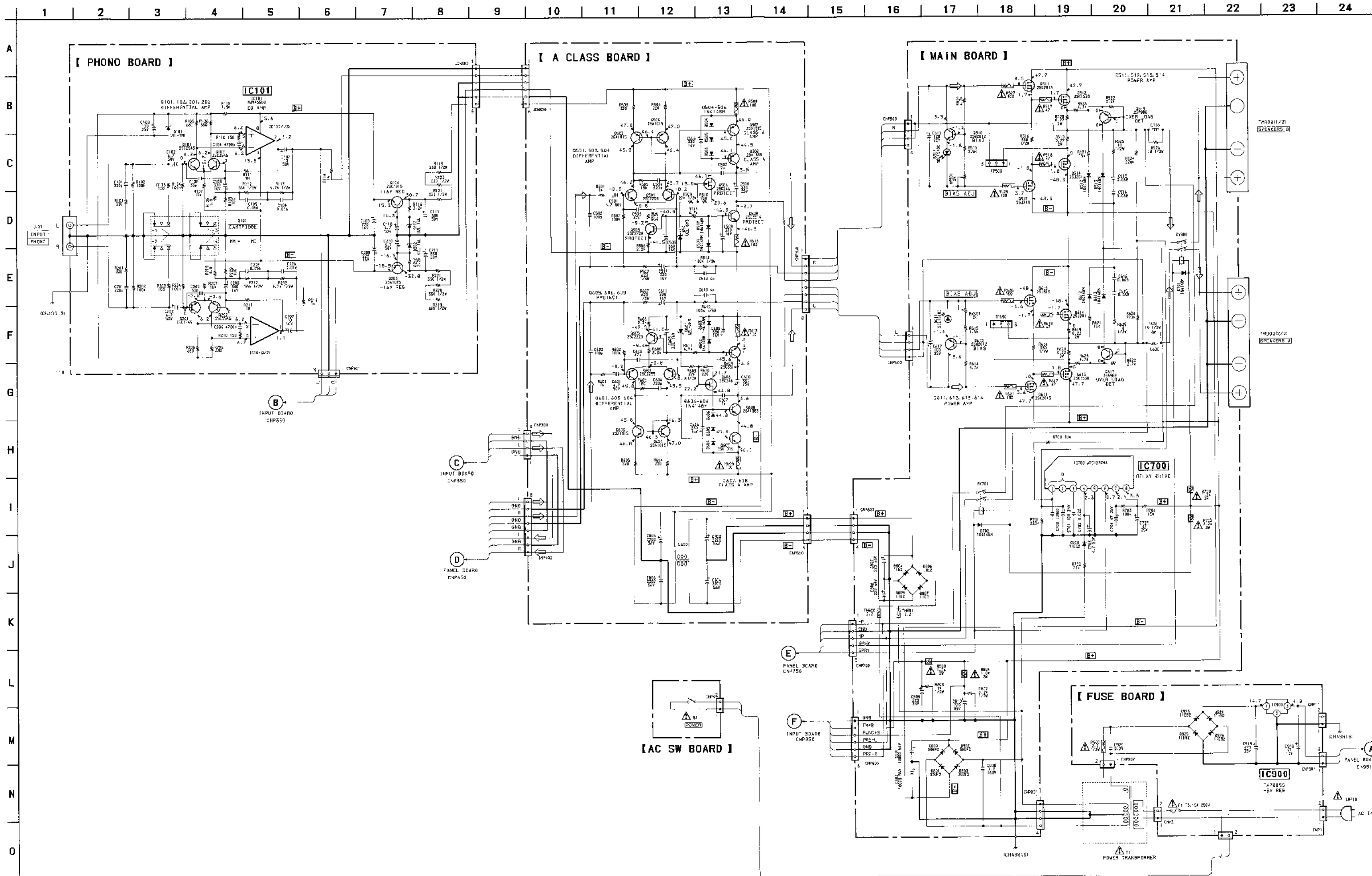

• IC Block Diagram

IC700 μ PC1237HA

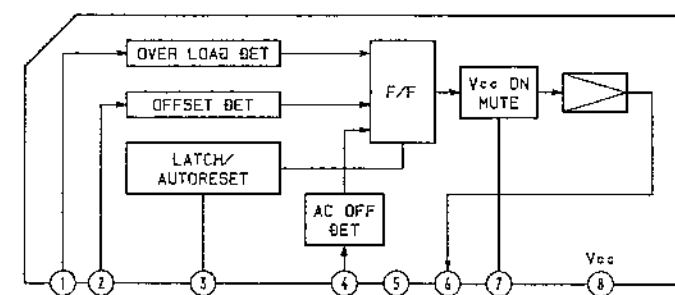

Note:

- All capacitors are in μ F unless otherwise noted. pF: μ F 50 WV or less are not indicated except for electrolytics and tantalums.
- All resistors are in Ω and $\frac{1}{4}$ W or less unless otherwise specified.
- : nonflammable resistor.
- : fusible resistor.

Note: The components identified by mark Δ or dotted line with mark Δ are critical for safety. Replace only with part number specified.

- $B+$: B + Line.
- $B-$: B - Line.
- : adjustment for repair.
- Voltage is dc with respect to ground under no-signal conditions. no mark : PHONO
- Voltages are taken with a VOM (10 M Ω/V). Voltage variations may be noted due to normal production tolerances.
- Signal path.
- : FM

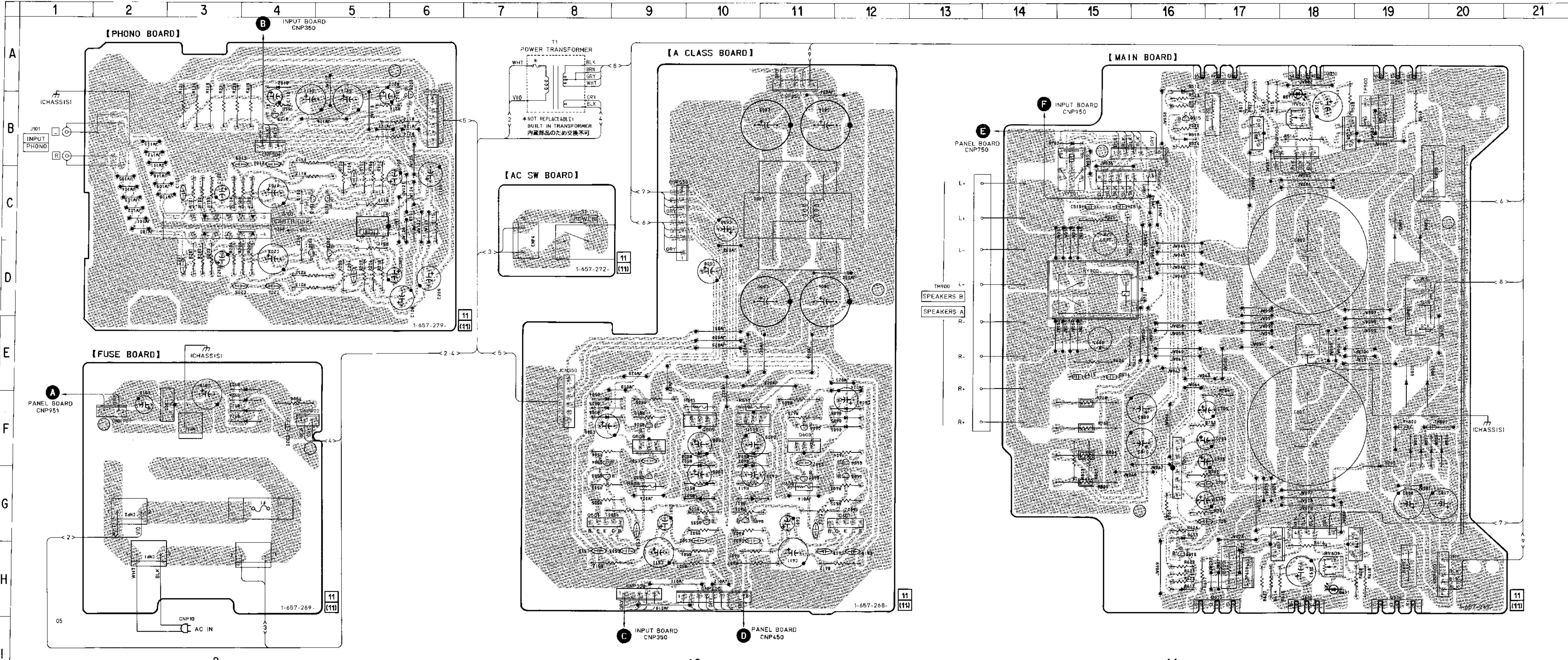

• Semiconductor Location

Ref. No.	Location	Ref. No.	Location
D101	C-6	IC101	C-5
D102	A-4	IC700	G-16
D202	A-5	IC900	F-2
D501	F-10	Q101	C-4
D502	F-10	Q102	C-5
D503	F-10	Q103	B-4
D504	F-8	Q201	D-4
D505	F-8	Q202	D-5
D506	F-8	Q203	B-6
D511	A-18	Q501	G-8
D512	A-16	Q503	G-8
D513	B-16	Q504	F-8
D601	G-10	Q505	G-10
D602	F-10	Q506	F-9
D603	F-10	Q507	G-9
D604	F-12	Q508	F-9
D605	F-12	Q509	F-10
D606	F-12	Q510	A-18
D611	H-18	Q511	B-17
D612	H-16	Q512	B-18
D613	G-16	Q513	A-17
D700	F-19	Q514	A-19
D701	D-16	Q515	B-16
D702	B-15	Q601	G-11
D800	E-19	Q603	G-12
D801	C-19	Q604	F-12
D802	E-19	Q605	G-10
D803	C-19	Q606	F-11
D804	F-19	Q607	G-11
D805	F-19	Q608	F-11
D806	F-20	Q609	F-10
D807	F-19	Q610	H-18
D823	E-4	Q611	G-17
D824	F-4	Q612	G-18
D825	F-4	Q613	H-17
D826	F-4	Q614	H-19
		Q615	H-16

Note:
 • ○ : parts extracted from the component side.
 • ⊞ : Pattern from the side which enables seeing.

• Semiconductor Location

Ref. No.	Location
D103	C-11
D104	C-11
D105	C-11
D106	B-11
D107	D-10
D108	B-10
D900	G-18
D901	G-12
D902	G-12
D903	G-12
D904	G-12
D905	G-12
D906	G-12
D907	G-12
D908	H-18
D909	D-10
D910	F-19
D911	F-12
D912	B-16
D913	B-16
D914	A-7
D915	A-6
D916	A-6
D917	A-5
D918	A-4
D919	A-4
D920	C-3
D921	C-7
D922	A-2
IC901	G-14
IC902	G-15
IC903	G-16
IC904	D-16
IC905	G-16
Q150	C-11
Q151	D-11
Q152	D-11
Q153	D-11
Q154	C-10
Q155	C-10
Q901	G-12
Q902	H-18
Q903	H-18
Q904	H-18
Q911	G-15
Q912	G-15
Q913	D-10
Q914	G-12

Note:
 • : parts extracted from the component side.
 • : Pattern from the side which enables seeing.

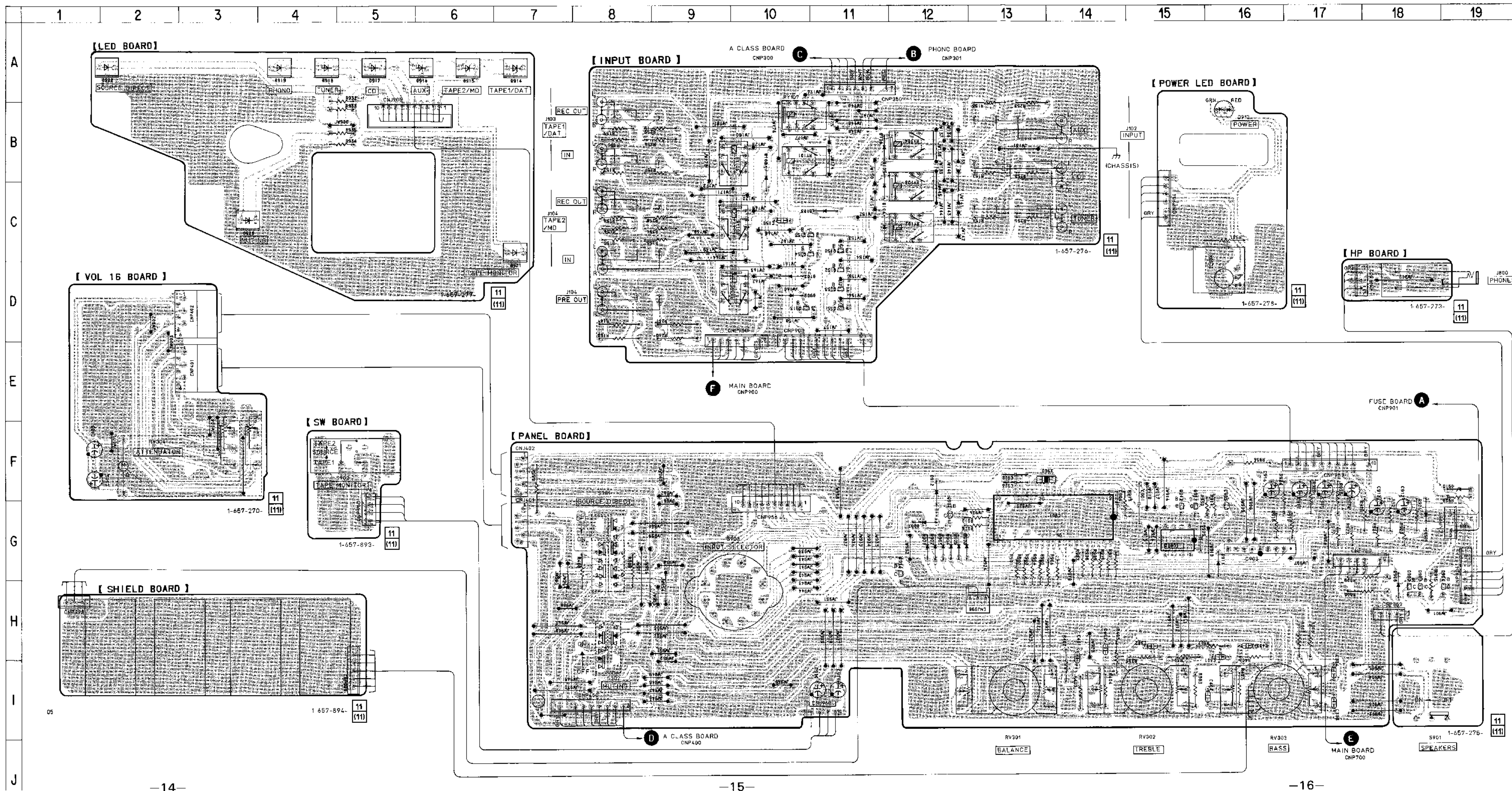

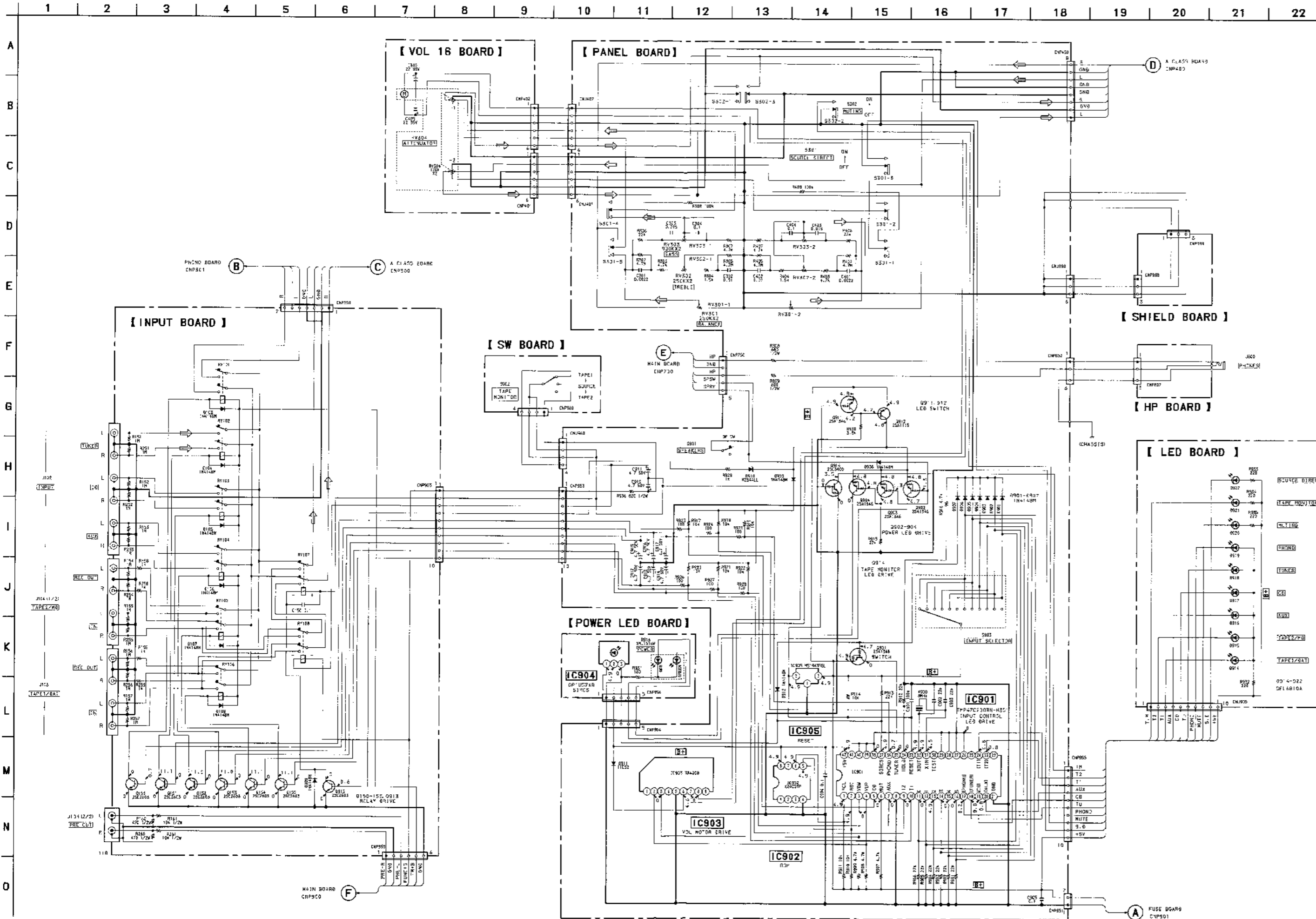

IC Block Diagrams

IC902 X24C01P-S

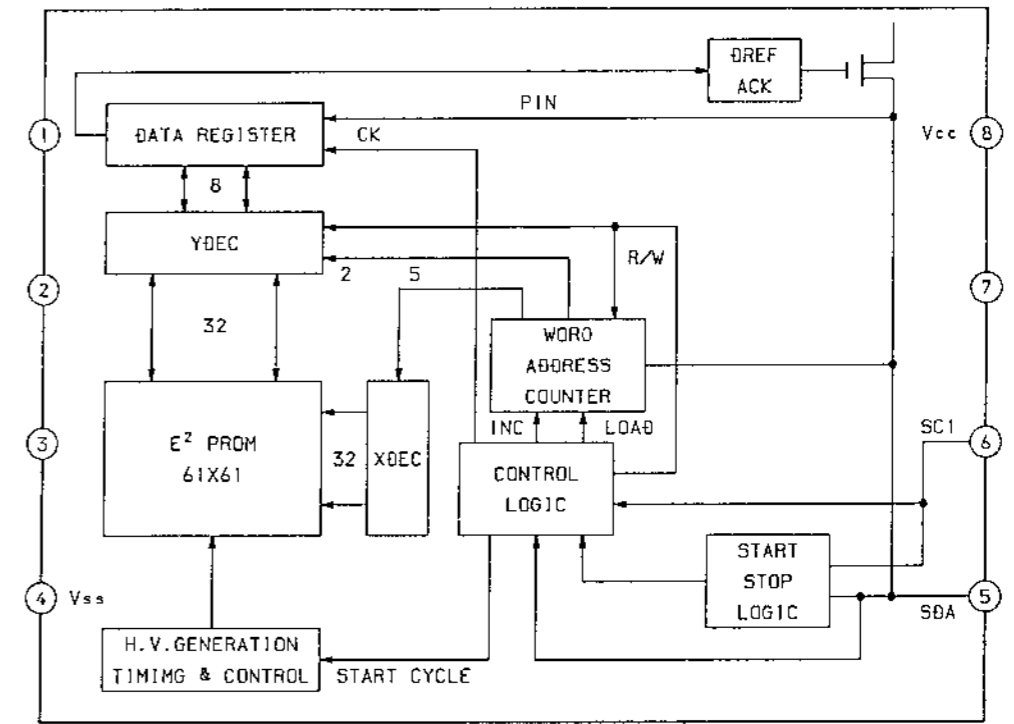

IC903 BA6208

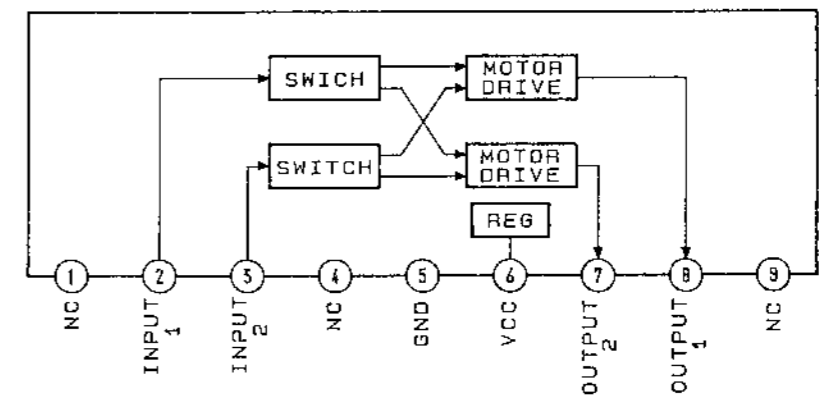

- Note:
- All capacitors are in μF unless otherwise noted. pF ; μF 50 WV or less are not indicated except for electrolytics and tantalums.
 - All resistors are in Ω and $\frac{1}{4}$ W or less unless otherwise specified.
 - B+** : B + Line.
 - B-** : B - Line.
 - Voltage is dc with respect to ground under no-signal conditions. no mark : PHONO
 - Voltages are taken with a VOM (10 M Ω /V). Voltage variations may be noted due to normal production tolerances.
 - Signal path.
 - \square : FM

SECTION 4 EXPLODED VIEWS

NOTE:

- Items marked "*" are not stocked since they are seldom required for routine service. Some delay should be anticipated when ordering these items.
- The mechanical parts with no reference number in the exploded views are not supplied.

The components identified by mark or dotted line with mark are critical for safety. Replace only with part number specified.

(1) CASE, FRONT PANEL SECTION-1

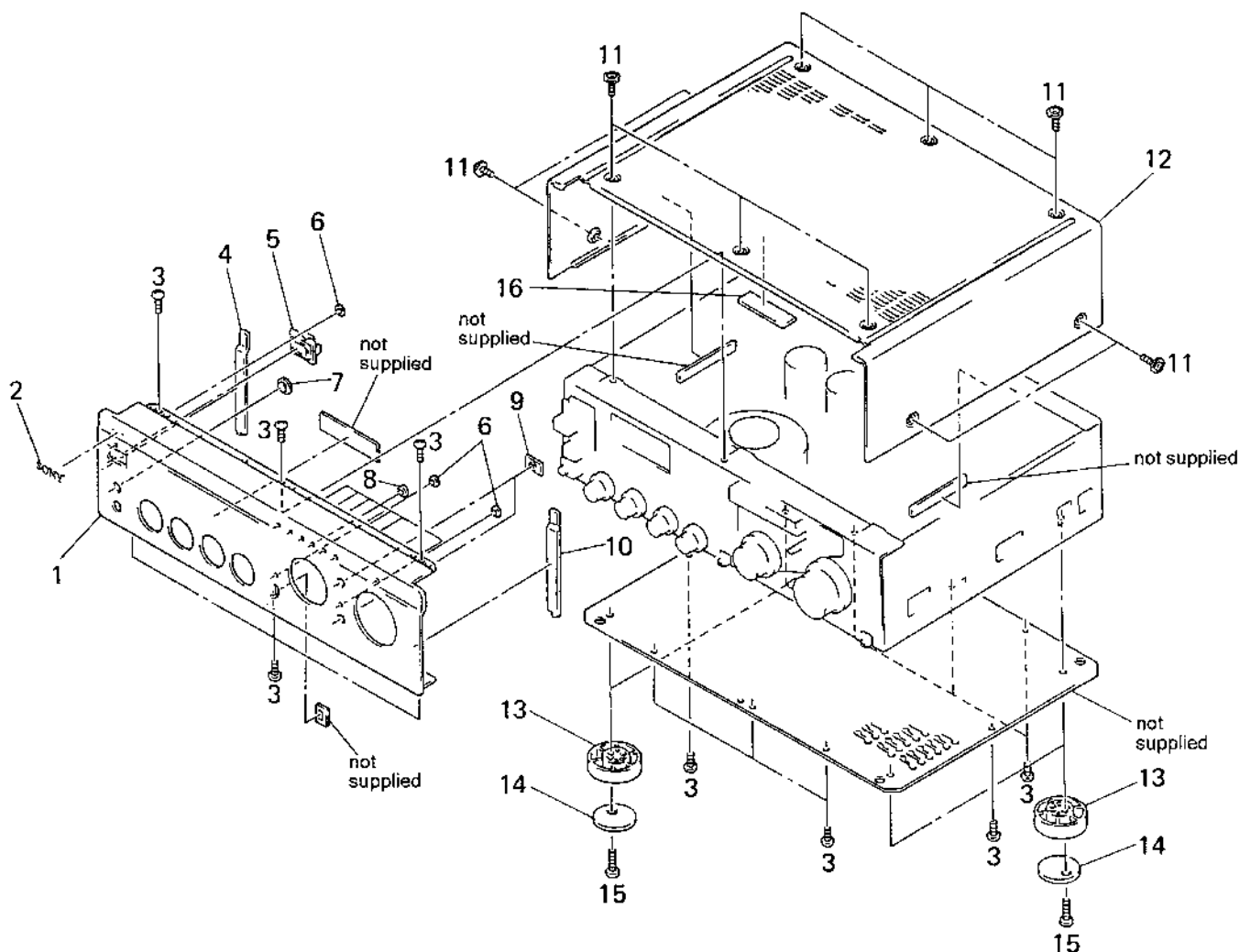

Ref. No.	Part No.	Description	Remark	Ref. No.	Part No.	Description	Remark
1	4-975-093-11	PANEL, FRONT		9	4-970-145-01	ESCUTCHEON (P)	
2	4-942-568-01	EMBLEM (NO. 5), SONY		10	4-975-104-01	PLATE (R), ORNAMENTAL	
3	4-967-961-01	SCREW (3X8) (SPECIAL)		11	3-704-366-01	SCREW (CASE) (M3X8)	
4	4-975-103-01	PLATE (L), ORNAMENTAL		12	4-975-095-11	COVER, UPPER	
5	4-908-044-11	ESCUTCHEON, POWER KNOB		13	4-970-123-01	FOOT (F50180S)	
6	4-970-486-01	LENS, LED		14	4-970-124-01	CUSHION (F50180S)	
7	4-975-105-01	WINDOW, RAY CATCHER		15	7-682-565-09	SCREW +B 4X16	
8	4-969-325-11	LENS, LED		* 16	4-976-524-01	DAMPER	

(2) FRONT PANEL SECTION-2

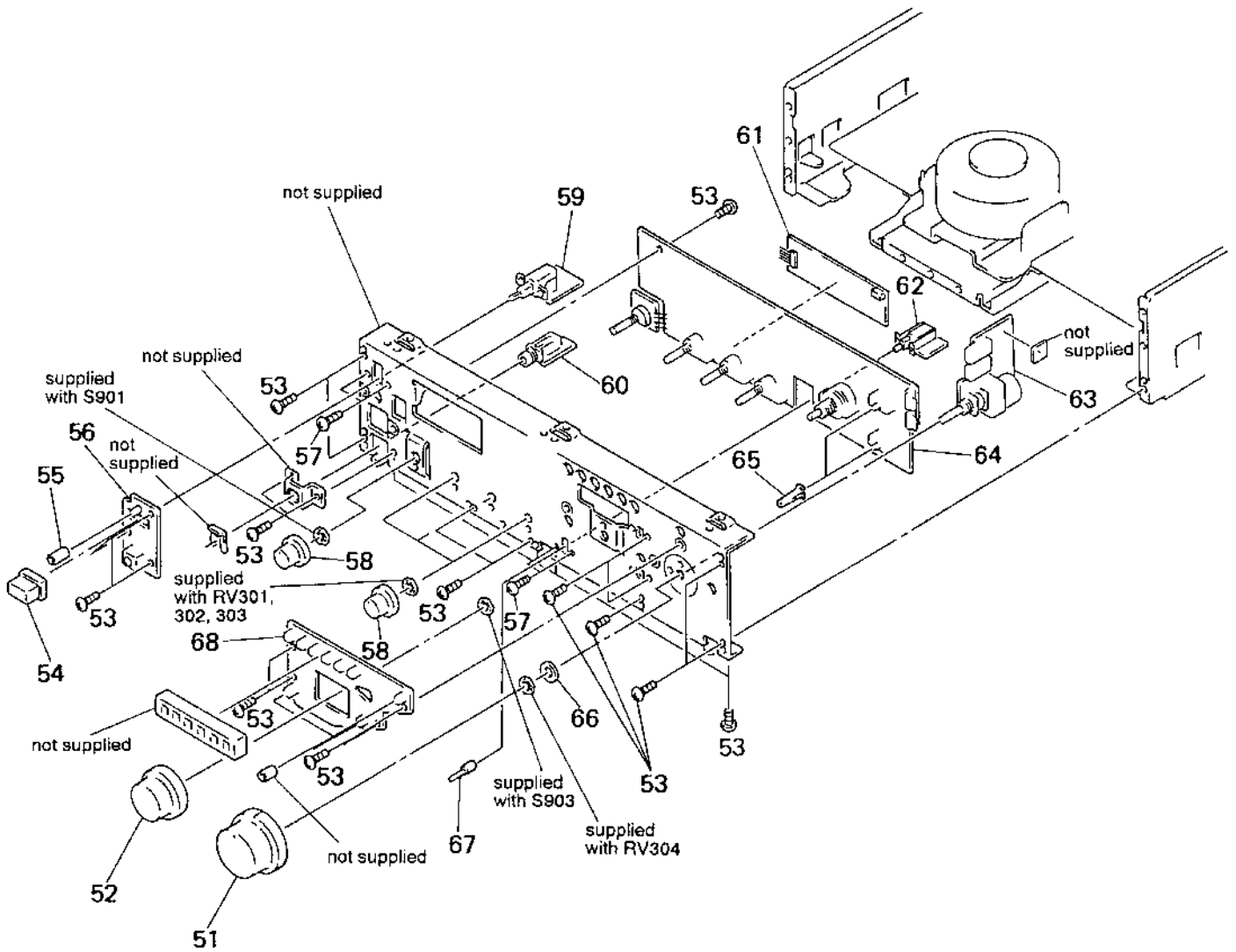

Ref. No.	Part No.	Description	Remark	Ref. No.	Part No.	Description	Remark
51	X-4945-357-1	KNOB (VB) ASSY		* 60	1-657-273-11	HP BOARD	
52	4-970-148-01	KNOB (I)		* 61	1-657-894-11	SHIELD BOARD	
53	4-967-961-01	SCREW (3X8) (SPECTAL)		* 62	1-657-893-11	SW BOARD	
54	4-969-330-01	KNOB (POWER)		* 63	1-657-270-11	VOL 16 BOARD	
* 55	4-971-834-01	TUBE (B), LIGHT INTERCEPTON		* 64	A 4378-378-A	PANEL BOARD, COMPLETE	
* 56	1-657-278-11	POWER LED BOARD		65	4-970-146-01	BUTTON	
57	4-967-959-01	SCREW (3X6)		66	4-972-113-01	WASHER	
58	4-970-152-01	KNOB (R)		67	4-976-796-01	KNOB (A), LEVER	
* 59	1-657-272-11	AC SW BOARD		* 68	1-657-277-11	LED BOARD	

(3) CHASSIS SECTION

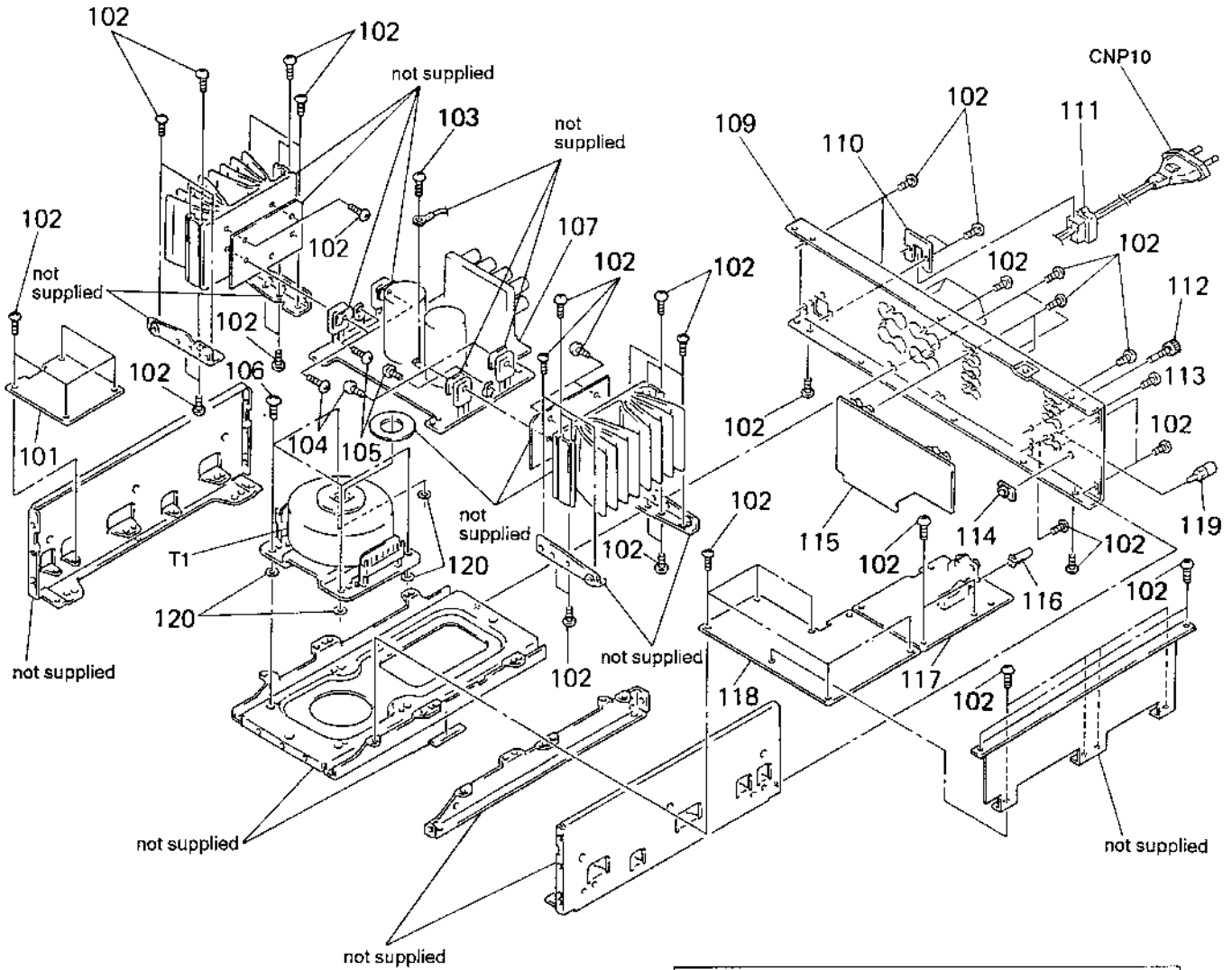

Note: The components identified by mark Δ or dotted line with mark Δ are critical for safety. Replace only with part number specified.

Ref. No.	Part No.	Description	Remark
* 101	1-657-269 11	FUSE BOARD	
102	4-967-961-01	SCREW (3X8) (SPECIAL)	
103	4-967-959-01	SCREW (3X6)	
104	4-956-589-01	SCREW (3X14), +B (COPPER PLATING)	
105	4-969-221-01	SCREW (3X12)	
106	4-967-960-01	SCREW (4X8)	
* 107	A-4378-383-A	MAIN BOARD, COMPLETE	
* 109	4-975-098-11	PANEL, BACK	
* 110	4-923-873-01	BRACKET, CORD STOPPER	
* 111	3-703-244-00	BUSHING (2104), CORD	
112	4-947-010-01	SCREW, FEEDER FIXED	

Ref. No.	Part No.	Description	Remark
113	3-704-515-41	SCREW (BV/RING)	
114	4-970-145-01	ESCUTCHEON (P)	
* 115	1-657-276-11	INPUT BOARD	
116	4-970-146-01	BUTTON	
* 117	A-4378-387-A	PHONO BOARD, COMPLETE	
* 118	A-4378-384-A	A CLASS BOARD, COMPLETE	
119	1-506-113-00	SHORT PLUG	
* 120	4-949-933-01	WASHER (K.F)	
Δ CNP10	1-574-805-31	CORD, POWER	
Δ T1	1-429-093-11	TRANSFORMER, POWER	

SECTION 5 ELECTRICAL PARTS LIST

A CLASS

NOTE:

- Due to standardization, replacements in the parts list may be different from the parts specified in the diagrams or the components used on the set.
- -XX and -X mean standardized parts, so they may have some difference from the original one.
- RESISTORS
All resistors are in ohms.
METAL: Metal-film resistor.
METAL OXIDE: Metal oxide-film resistor.
F: nonflammable

- Items marked "*" are not stocked since they are seldom required for routine service. Some delay should be anticipated when ordering these items.
- SEMICONDUCTORS
In each case, u: μ , for example:
uA .. : μ A., uPA .. : μ PA.,
uPB .. : μ PB., uPC .. : μ PC., uPD .. : μ PD.
- CAPACITORS
uF: μ F
- COILS
uH: μ H

The components identified by mark Δ or dotted line with mark Δ are critical for safety. Replace only with part number specified.

When indicating parts by reference number, please include the board.

Ref. No.	Part No.	Description	Remark	Ref. No.	Part No.	Description	Remark
*	A-4378-384 A	A CLASS BOARD, COMPLETE *****		D502	8-719-987-63	DIODE 1N4148M	
		< CAPACITOR >		D503	8-719-987-63	DIODE 1N4148M	
C501	1-126-163-11	ELECT 4.7uF	20% 50V	D504	8-719-987-63	DIODE 1N4148M	
C502	1-104-278-11	POLYSTYRENE 100PF	5% 50V	D505	8-719-987-63	DIODE 1N4148M	
C503	1-104-274-11	POLYSTYRENE 47PF	10% 50V	D506	8-719-987-63	DIODE 1N4148M	
C504	1-104-286-11	POLYSTYRENE 220PF	5% 50V	D601	8-719-933-41	DIODE HZS6C3L	
C505	1-126-011-11	ELECT 330uF	20% 16V	D602	8-719-987-63	DIODE 1N4148M	
C506	1-126-011-11	ELECT 330uF	20% 16V	D603	8-719-987-63	DIODE 1N4148M	
C507	1-113-497-91	POLYSTYRENE 7PF	10% 50V	D604	8-719-987-63	DIODE 1N4148M	
C508	1-126-025-11	ELECT 330uF	20% 25V	D605	8-719-987-63	DIODE 1N4148M	
C509	1-126-011-11	ELECT 330uF	20% 16V	D606	8-719-987-63	DIODE 1N4148M	
C510	1-113-496-91	POLYSTYRENE 4PF	10% 50V			< CONNECTOR >	
C511	1-126-024-11	ELECT 220uF	20% 16V	JCN350	1-770-832-11	CONNECTOR, BOARD TO BOARD 6P	
C601	1-126-163-11	ELECT 4.7uF	20% 50V			< COIL >	
C602	1-104-278-11	POLYSTYRENE 100PF	5% 50V	L800	1-411-342-11	COIL, CHOKE	
C603	1-104-274-11	POLYSTYRENE 47PF	10% 50V			< TRANSISTOR >	
C604	1-104-286-11	POLYSTYRENE 220PF	5% 50V	Q501	8-729-620-17	TRANSISTOR 2SC2259-FG	
C605	1-126-011-11	ELECT 330uF	20% 16V	Q503	8-729-201-53	TRANSISTOR 2SA1015-GR	
C606	1-126-011-11	ELECT 330uF	20% 16V	Q504	8-729-201-53	TRANSISTOR 2SA1015-GR	
C607	1-113-497-91	POLYSTYRENE 7PF	10% 50V	Q505	8-729-021-73	TRANSISTOR 2SC2229-OY-TPE6	
C608	1-126-025-11	ELECT 330uF	20% 25V	Q506	8-729-201-56	TRANSISTOR 2SK246-GR2	
C609	1-126-011-11	ELECT 330uF	20% 16V	Q507	8-729-201-53	TRANSISTOR 2SA1015-GR	
C610	1-113-496-91	POLYSTYRENE 4PF	10% 50V	Q508	8-729-104-91	TRANSISTOR 2SA1383	
C611	1-126-024-11	ELECT 220uF	20% 16V	Q509	8-729-104-18	TRANSISTOR 2SC3514-Q	
C803	1-113-618-11	ELECT 2200uF	20% 56V	Q601	8-729-620-17	TRANSISTOR 2SC2259-FG	
C804	1-113-618-11	ELECT 2200uF	20% 56V	Q603	8-729-201-53	TRANSISTOR 2SA1015-GR	
C805	1-113-618-11	ELECT 2200uF	20% 56V	Q604	8-729-201-53	TRANSISTOR 2SA1015-GR	
C806	1-113-618-11	ELECT 2200uF	20% 56V	Q605	8-729-021-73	TRANSISTOR 2SC2229-OY-TPE6	
		< CONNECTOR >		Q606	8-729-201-56	TRANSISTOR 2SK246-GR2	
CNP300	1-691-766-31	PLUG (MICRO CONNECTOR) 4P		Q607	8-729-201-53	TRANSISTOR 2SA1015-GR	
CNP400	1-691-770-11	PLUG (MICRO CONNECTOR) 8P		Q608	8-729-104-91	TRANSISTOR 2SA1383	
CNP550	1-691-770-21	PLUG (MICRO CONNECTOR) 8P		Q609	8-729-104-18	TRANSISTOR 2SC3514-Q	
CNP850	1-691-766-11	PLUG (MICRO CONNECTOR) 4P				< RESISTOR >	
		< DIODE >		R500	1-247-719-11	CARBON 3.3K 5% 1/4W	
D501	8-719-933-41	DIODE HZS6C3L					

A CLASS AC SW FUSE HP INPUT

Ref. No.	Part No.	Description	Remark		
R501	1-247-713-11	CARBON	1K	5%	1/4W
R502	1-249-469-11	CARBON	100K	5%	1/4W
R503	1-247-704-11	CARBON	220	5%	1/4W
R504	1-247-704-11	CARBON	220	5%	1/4W
R505	1-247-703-11	CARBON	180	5%	1/4W
R506	1-247-717-11	CARBON	2.2K	5%	1/4W
R507	1-247-235-00	CARBON	620	5%	1/3W
△R508	1-212-881-11	FUSIBLE	100	5%	1/4W F
R509	1-249-490-11	CARBON	27K	5%	1/2W
R510	1-247-704-11	CARBON	220	5%	1/4W
R511	1-247-721-11	CARBON	4.7K	5%	1/4W
R512	1-249-496-11	CARBON	100K	5%	1/3W
△R513	1-212-881-11	FUSIBLE	100	5%	1/4W F
R600	1-247-719-11	CARBON	3.3K	5%	1/4W
R601	1-247-713-11	CARBON	1K	5%	1/4W
R602	1-249-469-11	CARBON	100K	5%	1/4W
R603	1-247-704-11	CARBON	220	5%	1/4W
R604	1-247-704-11	CARBON	220	5%	1/4W
R605	1-247-703-11	CARBON	180	5%	1/4W
R606	1-247-717-11	CARBON	2.2K	5%	1/4W
R607	1-247-235-00	CARBON	620	5%	1/3W
△R608	1-212-881-11	FUSIBLE	100	5%	1/4W F
R609	1-249-490-11	CARBON	27K	5%	1/2W
R610	1-247-704-11	CARBON	220	5%	1/4W
R611	1-247-721-11	CARBON	4.7K	5%	1/4W
R612	1-249-496-11	CARBON	100K	5%	1/3W
△R613	1-212-881-11	FUSIBLE	100	5%	1/4W F

*	1-657-272-11	AC SW BOARD	*****		
		< CONNECTOR >			
CNP4	1-564-321-00	PIN, CONNECTOR 2P			
		< SWITCH >			
△S1	1-554-920-11	SWITCH, PUSH (AC POWER) (1 KEY) (POWER)			

*	1-657-269-11	FUSE BOARD	*****		
*	4-924-264-21	TERMINAL, MOUNT			
	1-533-293-11	FUSE HOLDER			
		< CAPACITOR >			
C918	1-104-664-11	ELECT	47uF	20%	10V
C919	1-126-971-11	ELECT	470uF	20%	35V
C920	1-136-153-00	FILM	0.01uF	5%	50V

Ref. No.	Part No.	Description	Remark		
< CONNECTOR >					
CNP1	1-564-321-00	PIN, CONNECTOR 2P			
* CNP2	1-564-321-21	PIN, CONNECTOR 2P			
CNP11	1-564-320-00	PIN, CONNECTOR (B2P-VH) 2P			
* CNP901	1-564-506-11	PLUG, CONNECTOR 3P			
CNP902	1-564-505-11	PLUG, CONNECTOR 2P			
< DIODE >					
D923	8-719-200-82	DIODE 11ES2			
D924	8-719-200-82	DIODE 11ES2			
D925	8-719-200-82	DIODE 11ES2			
D926	8-719-200-82	DIODE 11ES2			
< FUSE >					
△F1	1-532-237-00	FUSE, TIME LAG (3.15A 250V)			
< IC >					
IC900	8-759-231-53	IC TA7805S			
< RESISTOR >					
△R900	1-212-942-00	FUSIBLE 2.2 5% 1/2W F			

*	1-657-273-11	HP BOARD	*****		
< CONNECTOR >					
* CNP802	1-564-506-11	PLUG, CONNECTOR 3P			
< JACK >					
J800	1-507-796-71	JACK (PHONES)			

*	1-657-276-11	INPUT BOARD	*****		
< CAPACITOR >					
C150	1-136-165-00	FILM 0.1uF 5% 50V			
< CONNECTOR >					
CNP350	1-691-769-11	PLUG (MICRO CONNECTOR) 7P			
CNP903	1-691-772-11	PLUG (MICRO CONNECTOR) 10P			
CNP950	1-691-768-11	PLUG (MICRO CONNECTOR) 6P			
< DIODE >					
D103	8-719-987-63	DIODE 1N4148M			
D104	8-719-987-63	DIODE 1N4148M			
D105	8-719-987-63	DIODE 1N4148M			

The components identified by mark △ or dotted line with mark △ are critical for safety. Replace only with part number specified.

INPUT	LED	MAIN
-------	-----	------

Ref. No.	Part No.	Description	Remark
D106	8-719-987-63	DIODE 1N4148M	
D107	8-719-987-63	DIODE 1N4148M	
< JACK >			
J102	1-568-978-41	JACK 6P (INPUT:ALX, CD, TUNER)	
* J103	1-573-142-21	JACK, PIN 4P (TAPE 1/DAT:REC OUT, IN)	
J104	1-568-978-11	JACK 6P (TAPE 2/MD:REC OUT, IN) (PRE OUT)	
< TRANSISTOR >			
Q150	8-729-620-05	TRANSISTOR 2SC2603-EF	
Q151	8-729-620 05	TRANSISTOR 2SC2603-EF	
< RESISTOR >			
R151	1-249-995-11	CARBON 1M 5% 1/4W	
R152	1-249-995-11	CARBON 1M 5% 1/4W	
R153	1-249-995-11	CARBON 1M 5% 1/4W	
R154	1-249-995-11	CARBON 1M 5% 1/4W	
R155	1-249-995-11	CARBON 1M 5% 1/4W	
R156	1-249-995-11	CARBON 1M 5% 1/4W	
R157	1-249-995-11	CARBON 1M 5% 1/4W	
R158	1-247-713-11	CARBON 1K 5% 1/4W	
R159	1-247-713-11	CARBON 1K 5% 1/4W	
R160	1-247-747 11	CARBON 470 5% 1/2W	
R161	1-247-764-11	CARBON 10K 5% 1/2W	
R251	1-249-995-11	CARBON 1M 5% 1/4W	
R252	1-249-995-11	CARBON 1M 5% 1/4W	
R253	1-249-995-11	CARBON 1M 5% 1/4W	
R254	1-249-995-11	CARBON 1M 5% 1/4W	
R255	1-249-995-11	CARBON 1M 5% 1/4W	
R256	1-249-995-11	CARBON 1M 5% 1/4W	
R257	1-249-995-11	CARBON 1M 5% 1/4W	
R258	1-247-713-11	CARBON 1K 5% 1/4W	
R259	1-247-713-11	CARBON 1K 5% 1/4W	
R260	1-247-747-11	CARBON 470 5% 1/2W	
R261	1-247-764-11	CARBON 10K 5% 1/2W	
< RELAY >			
RY101	1-755-112-11	RELAY	
RY102	1-755-112-11	RELAY	
RY103	1-755-112-11	RELAY	
RY104	1-755-112-11	RELAY	
RY105	1-755-112-11	RELAY	
RY106	1-755-112-11	RELAY	
RY107	1-755-112-11	RELAY	
RY108	1-755-112-11	RELAY	

Ref. No.	Part No.	Description	Remark
*	1-657-277-11	LED BOARD *****	
< CONNECTOR >			
CNJ905	1 766-797-11	CONNECTOR, BOARD TO BOARD 10P	
< DIODE >			
D914	8-719-313-72	LED SEL3810A-CD (TAPE 1/DAT)	
D915	8-719-313-72	LED SEL3810A-CD (TAPE 2/MD)	
D916	8-719-313-72	LED SEL3810A-CD (AUX)	
D917	8-719-313-72	LED SEL3810A-CD (CD)	
D918	8-719-313-72	LED SEL3810A-CD (TUNER)	
D919	8-719-313-72	LED SEL3810A CD (PHONE)	
D920	8-719-313-72	LED SEL3810A CD (MUTING)	
D921	8-719-313-72	LED SEL3810A-CD (TAPE MONITOR)	
D922	8-719-301-49	LED SEL2810A (SOURCE DIRECT)	
< TRANSISTOR >			
Q152	8-729-620-05	TRANSISTOR 2SC2603-EF	
Q153	8-729-620-05	TRANSISTOR 2SC2603-EF	
Q154	8-729-620-05	TRANSISTOR 2SC2603-EF	
Q155	8-729-620-05	TRANSISTOR 2SC2603-EF	
Q913	8-729-620-05	TRANSISTOR 2SC2603-EF	
< RESISTOR >			
R932	1-249-409-11	CARBON 220 5% 1/4W	
R933	1-249-409-11	CARBON 220 5% 1/4W	
R934	1-249-409-11	CARBON 220 5% 1/4W	
R935	1-249-409-11	CARBON 220 5% 1/4W	

*	A-4378-383-A	MAIN BOARD, COMPLETE *****	
< CAPACITOR >			
C512	1-126-023-11	ELECT 100uF 20% 25V	
C515	1-136-163-00	FILM 0.068uF 5% 50V	
C516	1-136-163-00	FILM 0.068uF 5% 50V	
C612	1-126-023-11	ELECT 100uF 20% 25V	
C615	1-136-163-00	FILM 0.068uF 5% 50V	
C616	1-136-163-00	FILM 0.068uF 5% 50V	
C700	1-164 085-11	CERAMIC 0.001uF 10% 50V	
C701	1-126-023-11	ELECT 100uF 20% 25V	
C702	1-136-157-00	FILM 0.022uF 5% 50V	
C703	1-126-963-11	ELECT 4.7uF 20% 50V	
C704	1-124-477-11	ELECT 47uF 20% 25V	
C705	1-124-477-11	ELECT 47uF 20% 25V	
C800	1-136-880-11	FILM 2.2uF 10% 160V	
C801	1-111-742-11	ELECT 10000uF 20% 56V	
C802	1-111-742-11	ELECT 10000uF 20% 56V	

MAIN

Ref. No.	Part No.	Description	Remark
C807	1-126-064-11	ELECT 220uF	20% 63V
C808	1-126-064-11	ELECT 220uF	20% 63V
C809	1-124-484-11	ELECT 220uF	20% 35V
C810	1-124-484-11	ELECT 220uF	20% 35V

< CONNECTOR >

CNP500	1-691-766-21	PLUG (MICRO CONNECTOR) 4P	
CNP600	1-691-766-31	PLUG (MICRO CONNECTOR) 4P	
CNP700	1-691-767-41	PLUG (MICRO CONNECTOR) 5P	
CNP800	1-691-766-11	PLUG (MICRO CONNECTOR) 4P	
CNP801	1-766-897-11	PIN, CONNECTOR (PC BOARD) 4P	

CNP900	1-691-768-11	PLUG (MICRO CONNECTOR) 6P	
--------	--------------	---------------------------	--

< DIODE >

D511	8-719-310-60	LED SEL1510C-C	
D512	8-719-987-63	DIODE 1N4148M	
D513	8-719-987-63	DIODE 1N4148M	
D611	8-719-310-60	LED SEL1510C-C	
D612	8-719-987-63	DIODE 1N4148M	

D613	8-719-987-63	DIODE 1N4148M	
D700	8-719-200-82	DIODE 11ES2	
D701	8-719-987-63	DIODE 1N4148M	
D702	8-719-987-63	DIODE 1N4148M	
D800	8-719-054-76	DIODE 30DF2-FC3	

D801	8-719-054-76	DIODE 30DF2-FC3	
D802	8-719-054-76	DIODE 30DF2-FC3	
D803	8-719-054-76	DIODE 30DF2-FC3	
D804	8-719-200-02	DIODE 10E2	
D805	8-719-200-02	DIODE 10E2	

D806	8-719-200-02	DIODE 10E2	
D807	8-719-200-02	DIODE 10E2	

< IC >

IC700	8-759-111-68	IC uPC1237HA	
-------	--------------	--------------	--

< COIL >

L500	1-428-133-31	COIL, AIR-CORE	
L600	1-428-133-31	COIL, AIR-CORE	

< TRANSISTOR >

Q510	8-729-209-15	TRANSISTOR 2SD2012	
Q511	8-729-018-19	TRANSISTOR 2SK2013-Y	
Q512	8-729-018-21	TRANSISTOR 2SJ313-Y	
Q513	8-729-015-30	TRANSISTOR 2SK1530-Y	
Q514	8-729-015-31	TRANSISTOR 2SJ201-Y	
Q515	8-729-140-82	TRANSISTOR 2SA988 PAFAEA	
Q610	8-729-209-15	TRANSISTOR 2SD2012	
Q611	8-729-018-19	TRANSISTOR 2SK2013-Y	

Ref. No.	Part No.	Description	Remark
Q612	8-729-018-21	TRANSISTOR 2SJ313-Y	
Q613	8-729-015-30	TRANSISTOR 2SK1530-Y	
Q614	8-729-015-31	TRANSISTOR 2SJ201-Y	
Q615	8-729-140-82	TRANSISTOR 2SA988-PAFAEA	

< RESISTOR >

R514	1-247-721-11	CARBON 4.7K 5%	1/4W
R515	1-249-556-11	CARBON 1.5K 5%	1/4W
R516	1-247-745-11	CARBON 330 5%	1/2W
△R517	1-212-873-11	FUSIBLE 47 5%	1/4W F
△R518	1-212-873-11	FUSIBLE 47 5%	1/4W F

R519	1-217-151-00	RES, METAL PLATE 0.2	
R520	1-217-151-00	RES, METAL PLATE 0.2	
R521	1-249-431-11	CARBON 15K 5%	1/4W
R522	1-249-421-11	CARBON 2.2K 5%	1/4W
R523	1-249-425-11	CARBON 4.7K 5%	1/4W

R524	1-247-887-00	CARBON 220K 5%	1/4W
R525	1-247-727-11	CARBON 10 5%	1/2W
R526	1-247-727-11	CARBON 10 5%	1/2W
△R527	1-212-881-11	FUSIBLE 100 5%	1/4W F
△R528	1-212-881-11	FUSIBLE 100 5%	1/4W F

R614	1-247-721-11	CARBON 4.7K 5%	1/4W
R615	1-249-556-11	CARBON 1.5K 5%	1/4W
R616	1-247-745-11	CARBON 330 5%	1/2W
△R617	1-212-873-11	FUSIBLE 47 5%	1/4W F
△R618	1-212-873-11	FUSIBLE 47 5%	1/4W F

R619	1-217-151-00	RES, METAL PLATE 0.22	
R620	1-217-151-00	RES, METAL PLATE 0.22	
R621	1-249-431-11	CARBON 15K 5%	1/4W
R622	1-249-421-11	CARBON 2.2K 5%	1/4W
R623	1-249-425-11	CARBON 4.7K 5%	1/4W

R624	1-247-887-00	CARBON 220K 5%	1/4W
R625	1-247-727-11	CARBON 10 5%	1/2W
R626	1-247-727-11	CARBON 10 5%	1/2W
△R627	1-212-881-11	FUSIBLE 100 5%	1/4W F
△R628	1-212-881-11	FUSIBLE 100 5%	1/4W F

R700	1-249-429-11	CARBON 10K 5%	1/4W
R701	1-247-887-00	CARBON 220K 5%	1/4W
R702	1-249-433-11	CARBON 22K 5%	1/4W
R703	1-249-441-11	CARBON 100K 5%	1/4W
R704	1-249-431-11	CARBON 15K 5%	1/4W

△R705	1-215-919-11	METAL OXIDE 2.2K 5%	3W F
△R708	1-216-481-11	METAL OXIDE 1.2K 5%	3W F
△R800	1-216-481-11	METAL OXIDE 1.2K 5%	3W F
R803	1-247-752-11	CARBON 1K 5%	1/2W
△R804	1-215-917-11	METAL OXIDE 1K 5%	3W F

R807	1-247-756-11	CARBON 2.2K 5%	1/2W
------	--------------	----------------	------

The components identified by mark △ or dotted line with mark △ are critical for safety. Replace only with part number specified.

MAIN	PANEL
-------------	--------------

Ref. No.	Part No.	Description	Remark
< VARIABLE RESISTOR >			
RV501	1-237-457-21	RES, ADJ, CARBON 2K	
RV601	1-237-457-21	RES, ADJ, CARBON 2K	
< RELAY >			
RY701	1-755-112-11	RELAY	
RY900	1-515-920-11	RELAY (24V)	
< THERMISTOR >			
TH800	1-806-882-11	THERMISTOR, POSITIVE 2.2	
TH801	1-806-882-11	THERMISTOR, POSITIVE 2.2	
< TERMINAL >			
TM900	1-537-227-11	TERMINAL BOARD (SP) (SPEAKER B, SPEAKER A)	
< TEST PIN >			
* TP500	1-564-506-11	PLUG, CONNECTOR 3P	
* TP600	1-564-506-11	PLUG, CONNECTOR 3P	

*	A-4378-378-A	PANEL BOARD, COMPLETE	*****
< CAPACITOR >			
C301	1-130-475-00	MYLAR	0.0022uF 5% 50V
C302	1-136-153-00	FILM	0.01uF 5% 50V
C303	1-136-155-00	FILM	0.015uF 5% 50V
C304	1-136-165-00	FILM	0.1uF 5% 50V
C401	1-130-475-00	MYLAR	0.0022uF 5% 50V
C402	1-136-153-00	FILM	0.01uF 5% 50V
C403	1-136-155-00	FILM	0.015uF 5% 50V
C404	1-136-165-00	FILM	0.1uF 5% 50V
C901	1-162-282-31	CERAMIC	100PF 10% 50V
C902	1-162-207-31	CERAMIC	22PF 5% 50V
C903	1-162-207-31	CERAMIC	22PF 5% 50V
C904	1-164-159-11	CERAMIC	0.1uF 50V
C905	1-164-159-11	CERAMIC	0.1uF 50V
C910	1-126-963-11	ELECT	4.7uF 20% 50V
C911	1-126-963-11	ELECT	4.7uF 20% 50V
C912	1-126-963-11	ELECT	4.7uF 20% 50V
C913	1-126-963-11	ELECT	4.7uF 20% 50V
C914	1-126-963-11	ELECT	4.7uF 20% 50V
C915	1-126-963-11	ELECT	4.7uF 20% 50V
C916	1-126-963-11	ELECT	4.7uF 20% 50V
C917	1-126-963-11	ELECT	4.7uF 20% 50V

Ref. No.	Part No.	Description	Remark
< CONNECTOR >			
* CNJ401	1-568-318-21	PLUG, CONNECTOR 6P	
* CNJ402	1-568-318-21	PLUG, CONNECTOR 6P	
CNJ960	1-562-087-00	SOCKET, CONNECTOR 4P	
* CNJ998	1-565-835-11	SOCKET, CONNECTOR 3P	
CNP450	1-691-770-11	PLUG (MICRO CONNECTOR) 8P	
CNP750	1-691-767-41	PLUG (MICRO CONNECTOR) 5P	
* CNP852	1-564-506-11	PLUG, CONNECTOR 3P	
CNP904	1-691-767-11	PLUG (MICRO CONNECTOR) 5P	
* CNP951	1-564-506-11	PLUG, CONNECTOR 3P	
CNP953	1-691-772-11	PLUG (MICRO CONNECTOR) 10P	
CNP955	1-770-863-11	CONNECTOR, BOARD TO BOARD 10P	
< DIODE >			
D900	8-719-987-63	DIODE 1N4148M	
D901	8-719-987-63	DIODE 1N4148M	
D902	8-719-987-63	DIODE 1N4148M	
D903	8-719-987-63	DIODE 1N4148M	
D904	8-719-987-63	DIODE 1N4148M	
D905	8-719-987-63	DIODE 1N4148M	
D906	8-719-987-63	DIODE 1N4148M	
D907	8-719-987-63	DIODE 1N4148M	
D908	8-719-987-63	DIODE 1N4148M	
D910	8-719-985-53	DIODE HZS4ALL	
D911	8-719-200-82	DIODE 11ES2	
D912	8-719-987-63	DIODE 1N4148M	
< IC >			
IC901	8-759-352-00	IC TMP47C2008N-H351	
IC902	8-759-188-67	IC X24C01P-S	
IC903	8-759-962-08	IC BA6208	
IC905	8-759-635-63	IC M51943BSL	
< TRANSISTOR >			
Q901	8-729-900-63	TRANSISTOR DTA124ES	
Q902	8-729-900-63	TRANSISTOR DTA124ES	
Q903	8-729-900-63	TRANSISTOR DTA124ES	
Q904	8-729-900-63	TRANSISTOR DTA124ES	
Q911	8-729-900-63	TRANSISTOR DTA124ES	
Q912	8-729-119-76	TRANSISTOR 2SA1175-HFE	
Q914	8-729-900-36	TRANSISTOR DTC124ES	
< RESISTOR >			
R302	1-259-502-11	CARBON	4.7M 5% 1/4W
R303	1-247-721-11	CARBON	4.7K 5% 1/4W
R304	1-249-556-11	CARBON	1.5K 5% 1/4W
R305	1-259-502-11	CARBON	4.7M 5% 1/4W
R306	1-249-462-11	CARBON	22K 5% 1/4W

PANEL PHONO

Ref. No.	Part No.	Description	Remark
R307	1-247-721-11	CARBON	4.7K 5% 1/4W
R308	1-249-469-11	CARBON	100K 5% 1/4W
R402	1-259-502-11	CARBON	4.7M 5% 1/4W
R403	1-247-721-11	CARBON	4.7K 5% 1/4W
R404	1-249-556-11	CARBON	1.5K 5% 1/4W
R405	1-259-502-11	CARBON	4.7M 5% 1/4W
R406	1-249-462-11	CARBON	22K 5% 1/4W
R407	1-247-721-11	CARBON	4.7K 5% 1/4W
R408	1-249-469-11	CARBON	100K 5% 1/4W
R808	1-247-750-11	CARBON	680 5% 1/2W
R809	1-247-750-11	CARBON	680 5% 1/2W
R901	1-249-433-11	CARBON	22K 5% 1/4W
R902	1-249-433-11	CARBON	22K 5% 1/4W
R903	1-249-433-11	CARBON	22K 5% 1/4W
R904	1-249-433-11	CARBON	22K 5% 1/4W
R905	1-249-433-11	CARBON	22K 5% 1/4W
R906	1-249-433-11	CARBON	22K 5% 1/4W
R907	1-249-425-11	CARBON	4.7K 5% 1/4W
R908	1-249-425-11	CARBON	4.7K 5% 1/4W
R909	1-249-425-11	CARBON	4.7K 5% 1/4W
R910	1-249-429-11	CARBON	10K 5% 1/4W
R911	1-249-429-11	CARBON	10K 5% 1/4W
R912	1-249-433-11	CARBON	22K 5% 1/4W
R913	1-249-433-11	CARBON	22K 5% 1/4W
R914	1-249-429-11	CARBON	10K 5% 1/4W
R915	1-249-433-11	CARBON	22K 5% 1/4W
R916	1-249-425-11	CARBON	4.7K 5% 1/4W
R917	1-249-429-11	CARBON	10K 5% 1/4W
R918	1-249-429-11	CARBON	10K 5% 1/4W
R919	1-249-429-11	CARBON	10K 5% 1/4W
R920	1-249-429-11	CARBON	10K 5% 1/4W
R921	1-249-429-11	CARBON	10K 5% 1/4W
R922	1-249-429-11	CARBON	10K 5% 1/4W
R923	1-247-807-31	CARBON	100 5% 1/4W
R924	1-247-807-31	CARBON	100 5% 1/4W
R925	1-247-807-31	CARBON	100 5% 1/4W
R926	1-247-807-31	CARBON	100 5% 1/4W
R927	1-247-807-31	CARBON	100 5% 1/4W
R928	1-247-807-31	CARBON	100 5% 1/4W
R929	1-249-417-11	CARBON	1K 5% 1/4W
R930	1-249-423-11	CARBON	3.3K 5% 1/4W
R936	1-247-751-11	CARBON	820 5% 1/2W
R999	1-249-433-11	CARBON	22K 5% 1/4W
< VARIABLE RESISTOR >			
RV301	1-223-789-11	RES, VAR, CARBON 250K/250K	(BALANCE)
RV302	1-223-768-11	RES, VAR, CARBON 250K/250K	(TREBLE)
RV303	1-223-767-11	RES, VAR, CARBON 900K/900K	(BASS)

Ref. No.	Part No.	Description	Remark
< SWITCH >			
S301	1-762-393-11	SWITCH, PUSH (SOURCE DIRECT)	
S302	1-762-394-11	SWITCH, PUSH (1 KEY) (MUTING)	
S901	1-762-392-11	SWITCH, ROTARY (SPEAKERS)	
S903	1-762-183-11	SWITCH, ROTARY (INPUT SELECTOR)	
< VIBRATOR >			
X900	1-579-223-11	OSCILLATOR, CERAMIC (8MHz)	

* A-4378-387-A	PHONO BOARD, COMPLETE		

< CAPACITOR >			
C100	1-162-211-31	CERAMIC	33PF 5% 50V
C101	1-164-077-11	CERAMIC	220PF 10% 50V
C102	1-126-163-11	ELECT	4.7uF 20% 50V
C103	1-126-011-11	ELECT	330uF 20% 16V
C104	1-164-093-11	CERAMIC	0.0047uF 10% 25V
C105	1-136-162-00	FILM	0.056uF 5% 50V
C106	1-137-471-11	FILM	0.016uF 5% 50V
C107	1-126-059-11	ELECT	10uF 20% 50V
C108	1-126-023-11	ELECT	100uF 20% 25V
C109	1-126-024-11	ELECT	220uF 20% 16V
C110	1-126-163-11	ELECT	4.7uF 20% 50V
C111	1-126-054-61	ELECT	330uF 20% 50V
C200	1-162-211-31	CERAMIC	33PF 5% 50V
C201	1-164-077-11	CERAMIC	220PF 10% 50V
C202	1-126-163-11	ELECT	4.7uF 20% 50V
C203	1-126-011-11	ELECT	330uF 20% 16V
C204	1-164-093-11	CERAMIC	0.0047uF 10% 25V
C205	1-136-162-00	FILM	0.056uF 5% 50V
C206	1-137-471-11	FILM	0.016uF 5% 50V
C207	1-126-059-11	ELECT	10uF 20% 50V
C209	1-126-024-11	ELECT	220uF 20% 16V
C210	1-126-163-11	ELECT	4.7uF 20% 50V
C211	1-126-054-61	ELECT	330uF 20% 50V
< CONNECTOR >			
* CNP301	1-564-506-11	PLUG, CONNECTOR 3P	
< DIODE >			
D101	8-719-000-84	DIODE	UZL-7M1
D102	8-719-933-88	DIODE	HZS16-2L
D202	8-719-933-88	DIODE	HZS16-2L
< IC >			
IC101	8-759-745-61	IC	NJM4560D-D

PHONO

POWER LED

SHIELD

SW

Ref. No.	Part No.	Description	Remark
		< JACK >	
J101	1-568-250-21	JACK, PIN 2P (INPLT:PHONO)	
		< CONNECTOR >	
JCN300	1-770 831-11	CONNECTOR, BOARD TO BOARD 6P	
		< TRANSISTOR >	
Q101	8-729-354-52	TRANSISTOR 2SC2545	
Q102	8-729-354-52	TRANSISTOR 2SC2545	
Q103	8-729-119-78	TRANSISTOR 2SC27875 HFE	
Q201	8-729-354-52	TRANSISTOR 2SC2545	
Q202	8-729-354-52	TRANSISTOR 2SC2545	
Q203	8-729-201-53	TRANSISTOR 2SA1015-GR	
		< RESISTOR >	
R101	1-247 706-11	CARBON 330 5% 1/4W	
R102	1-249 469-11	CARBON 100K 5% 1/4W	
R103	1-247-700-11	CARBON 100 5% 1/4W	
R104	1-249-469-11	CARBON 100K 5% 1/4W	
R105	1-247-711-11	CARBON 880 5% 1/4W	
R106	1-247-711-11	CARBON 680 5% 1/4W	
R107	1-247-725-11	CARBON 10K 5% 1/4W	
R108	1-260-661-11	CARBON 6.8 5% 1/4W	
R109	1-247-700-11	CARBON 100 5% 1/4W	
R110	1-247-702-11	CARBON 150 5% 1/4W	
R111	1-249-995-11	CARBON 1M 5% 1/4W	
R112	1 249-844-11	CARBON 56K 1% 1/2W	
R113	1-249-818 11	CARBON 4.7K 1% 1/2W	
R114	1-247-713-11	CARBON 1K 5% 1/4W	
R115	1-249-556-11	CARBON 1.5K 5% 1/4W	
R116	1-259-436-11	CARBON 2.2K 5% 1/6W	
R119	1-249-661-11	CARBON 330 5% 1/2W	
R120	1-249-661-11	CARBON 330 5% 1/2W	
R121	1-249-661-11	CARBON 330 5% 1/2W	
R201	1-247-706-11	CARBON 330 5% 1/4W	
R202	1-249-469-11	CARBON 100K 5% 1/4W	
R203	1-247-700-11	CARBON 100 5% 1/4W	
R204	1-249-469-11	CARBON 100K 5% 1/4W	
R205	1 247-711-11	CARBON 680 5% 1/4W	
R206	1 247-711-11	CARBON 680 5% 1/4W	
R207	1-247-725 11	CARBON 10K 5% 1/4W	
R208	1-260-661 11	CARBON 6.8 5% 1/4W	
R209	1-247-700 11	CARBON 100 5% 1/4W	
R210	1-247-702 11	CARBON 150 5% 1/4W	
R211	1-249-995 11	CARBON 1M 5% 1/4W	
R212	1-249-844 11	CARBON 56K 1% 1/2W	
R213	1-249-818 11	CARBON 4.7K 1% 1/2W	

Ref. No.	Part No.	Description	Remark
R214	1-247-713-11	CARBON 1K 5% 1/4W	
R216	1-259-436-11	CARBON 2.2K 5% 1/6W	
R219	1-249-661-11	CARBON 330 5% 1/2W	
R220	1 249-661-11	CARBON 330 5% 1/2W	
R221	1-249 661-11	CARBON 330 5% 1/2W	
		< SWITCH >	
S101	1-762-395-11	SWITCH, PUSH (1 KEY) (CARTRIDGE)	

*	1-657-278-11	POWER LED BOARD	

		< CONNECTOR >	
CNP954	1-691-767 11	PLUG (MICRO CONNECTOR) 5P	
		< DIODE >	
D913	8-719-313-40	LED SEL1516W (POWER)	
		< IC >	
IC904	8-749-923-43	IC GPIU57XB	
		< RESISTOR >	
R931	1-249-408-11	CARBON 180 5% 1/4W	

*	1 657-894-11	SHIELD BOARD	

		< CONNECTOR >	
* CNP998	1-560-666-00	PIN, CONNECTOR 3P	
* CNP999	1-506-653-11	PIN CONNECTOR, B-B 5P	

*	1-657-893-11	SW BOARD	

		< CONNECTOR >	
CNP960	1 560-941-00	PIN, CONNECTOR 4P	
		< SWITCH >	
S902	1-762-165-11	SWITCH, LEVER SLIDE (TAPE MONITOR)	

VOL 16

Ref. No.	Part No.	Description	Remark
*	1-657-270-11	VOL 16 BOARD *****	
		< CAPACITOR >	
C305	1-128-551-11	ELECT 22uF	20% 35V
C405	1-128-551-11	ELECT 22uF	20% 35V
		< CONNECTOR >	
CNP401	1-568-317-11	SOCKET, CONNECTOR 6P	
CNP402	1-568-317-11	SOCKET, CONNECTOR 6P	
		< VARIABLE RESISTOR >	
RV304	1-223-937-11	RES, VAR, CARBON 120K/120K (ATTENUATOR)	

		MISCELLANEOUS *****	
119	1-506-113-00	SHORT PLUG	
△CNP10	1-574-805-31	CORD, POWER	
△T1	1-429-093-11	TRANSFORMER, POWER	

		ACCESSORIES & PACKING MATERIALS *****	
	1-693-108-11	REMOTE COMMANDER (RM-S702)	
	2-181-754-01	COVER, BATTERY (FOR RM-S702)	
	3-798-956-11	MANUAL, INSTRUCTION (ENGLISH, FRENCH, SPANISH, PORTUGUESE) (AEP)	
	3-798-956-21	MANUAL, INSTRUCTION (GERMAN, DUTCH, SWEDISH, ITALIAN)	
*	3-919-601-01	CUSHION	
*	3-919-604-41	INDIVIDUAL CARTON	

The components identified by
mark △ or dotted line with mark
△ are critical for safety.
Replace only with part number
specified.

TA-FA3ES

SONY SERVICE MANUAL

AEP Model

SUPPLEMENT-1

File this supplement with the service manual.



Subject : 1. CORRECTION
2. COLOR VARIATION (GOLD TYPE) ADDITION

(ECN-TA503701)

1. CORRECTION

Correct your service manual as shown below.

 : indicates corrected portion.

Page	INCORRECT			CORRECT	
	Ref.No.	Part No.	Description	Part No.	Description
23	JCN350	1-770-832-11	CONNECTOR, BOARD TO BOARD 6P	1-770-831-11 	CONNECTOR, BOARD TO BOARD 6P
29	JCN300	1-770-831-11	CONNECTOR, BOARD TO BOARD 6P	1-770-832-11 	CONNECTOR, BOARD TO BOARD 6P

2. COLOR VARIATION (GOLD TYPE) ADDITION

The others are common parts so that please refer to the previous issued service manual.

Page	Ref.No.	BLACK TYPE		GOLD TYPE	
		Part No.	Description	Part No.	Description
20	1	4-975-093-11	PANEL, FRONT	4-975-093-31	PANEL, FRONT
	2	4-942-568-01	EMBLEM (No.5), SONY	4-942-568-21	EMBLEM (No.5), SONY
	4	4-975-103-01	PLATE (L), ORNAMENTAL	4-975-103-11	PLATE (L), ORNAMENTAL
	7	4-975-105-01	WINDOW, RAY CATCHER	4-975-105-11	WINDOW, RAY CATCHER
	9	4-970-145-01	ESCUTCHEON (P)	4-970-145-11	ESCUTCHEON (P)
	10	4-975-104-01	PLATE (R), ORNAMENTAL	4-975-104-11	PLATE (R), ORNAMENTAL
	11	3-704-366-01	SCREW (CASE) (M3×8)	3-704-366-71	SCREW (CASE)
	12	4-975-095-11	COVER, UPPER	4-975-095-21	CASE
21	51	X-4945-357-1	KNOB (VB) ASSY	X-4945-359-1	KNOB (VG) ASSY
	52	4-970-148-01	KNOB (I)	4-970-148-11	KNOB (I)
	54	4-969-330-01	KNOB (POWER)	4-969-330-11	KNOB (POWER)
	58	4-970-152-01	KNOB (R)	4-970-152-11	KNOB (R)
	65	4-970-146-01	BUTTON	4-970-146-11	BUTTON
22	114	4-970-145-01	ESCUTCHEON (P)	4-970-145-11	ESCUTCHEON (P)
	116	4-970-146-01	BUTTON	4-970-146-11	BUTTON