

TA-F444ESX/F700ES

SERVICE MANUAL

TA-F444ESX:
E Model

TA-F700ES:
US Model
Canadian Model
AEP Model
UK Model

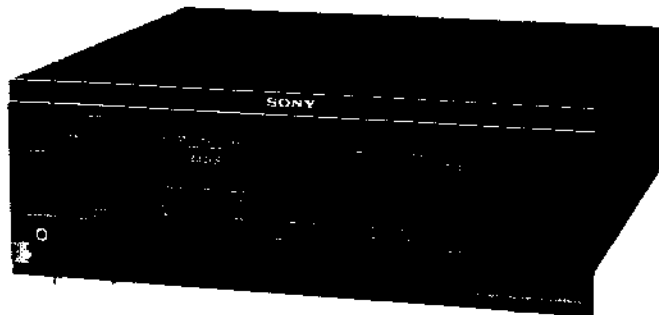

Photo: TA-F444ESX

SPECIFICATIONS

AUDIO POWER SPECIFICATIONS (US Model)

POWER OUTPUT AND TOTAL HARMONIC DISTORTION:

With 4 ohm loads, both channels driven, from 20 - 20,000 Hz; rated 140 watts per channel minimum RMS power, with no more than 0.008% total harmonic distortion from 250 milliwatts to rated output.

With 8 ohm loads, both channels driven, from 20 - 20,000 Hz; rated 105 watts per channel minimum RMS power, with no more than 0.004% total harmonic distortion from 250 milliwatts to rated output.

Power band - width (HF)	4 ohms.	10 Hz - 100 kHz
	0.02%	
Dynamic headroom (78 IHF)	8 ohms, THD 0.02%	10 Hz - 100 kHz
	4 ohms	3 dB
Total harmonic distortion	8 ohms	2 dB
	4 ohms, at 10 watt output	0.006%
Total harmonic distortion	6 ohms, at 10 watt output	0.004%
	8 ohms, at 10 watt output	0.002%

— Continued on page 2 —

OTHER SPECIFICATIONS

Item	Condition	Data
Continuous RMS power output (both channels driven simultaneously)	4 ohms 20 Hz - 20 kHz THD 0.008% 0.009% (G-AEP)	145 W + 145 W (AEP, G-AEP, UK, E)
	6 ohms 20 Hz - 20 kHz THD 0.006% 0.008% (G-AEP)	125 W + 125 W (AEP, G-AEP, UK, E)
		120 W + 120 W (US, Canadian, North European countries)
8 ohms 20 Hz - 20 kHz THD 0.004% 0.006% (G-AEP)	110 W + 110 W (AEP, G-AEP, UK, E)	
	105 W + 105 W (US, Canadian, North European countries)	

SAFETY-RELATED COMPONENT WARNING!!

COMPONENTS IDENTIFIED BY SHADING AND MARK  ON THE SCHEMATIC DIAGRAMS AND IN THE PARTS LIST ARE CRITICAL TO SAFE OPERATION. REPLACE THESE COMPONENTS WITH SONY PARTS WHOSE PART NUMBERS APPEAR AS SHOWN IN THIS MANUAL OR IN SUPPLEMENTS PUBLISHED BY SONY.

ATTENTION AU COMPOSANT AYANT RAPPORT A LA SECURITE!

LES COMPOSANTS IDENTIFIES PAR UNE TRAME ET UNE MARQUE  SUR LES DIAGRAMMES SCHEMATIQUES ET LA LISTE DES PIECES SONT CRITIQUES POUR LA SECURITE DE FONCTIONNEMENT. NE REMPLACER CES COMPOSANTS QUE PAR DES PIECES SONY DONT LES NUMEROS SONT DONNES DANS CE MANUEL OU DANS LES SUPPLEMENTS PUBLIES PAR SONY.

INTEGRATED STEREO AMPLIFIER

SONY®



TA-F444ESX/F700ES

Intermodulation (IM) distortion 60 Hz: 7 kHz = 4:1	4 ohms at rated output	0.008% 0.009% (G-AEP)
	6 ohms at rated output	0.006% 0.008% (G-AEP)
	8 ohms at rated output	0.004% 0.006% (G-AEP)
Damping factor	8 ohms, 1 kHz	100
Slew rate	—	125 V μ sec 250 V μ sec (inside)
Residual noise	network A	less than 115 μ V
Frequency response	PHONO MM	RIAA equalization curve ± 0.2 dB
	TUNER, CD TAPE 1, 2, 3	2 Hz - 200 kHz ± 0.3 dB 2 Hz - 100 kHz ± 0.3 dB (G-AEP)
Input sensitivity	PHONO MC 3 ohms	0.17 mV, 33 ohms (G-AEP)
		0.17 mV, 100 ohms (US, Canadian AEP, UK, E)
		40 ohms 0.17 mV, 100 ohms (G-AEP)
		0.17 mV, 1 kohm (US, Canadian AEP, UK, E)
		MM 2.5 mV, 50 kohms
	TUNER, CD, AUX, TAPE 1, 2, 3 ADAPTOR IN	150 mV, 50 kohms
Maximum input capability (1 kHz)	PHONO (1 kHz, THD 0.003%) MC	9 mV
	MM	150 mV
S/N (network)	PHONO MC	76 dB, 68 dB (A)
	MM	80 dB, 87 dB (A)
78 IHF	TUNER, CD, AUX, TAPE 1, 2, 3 ADAPTOR IN	84 dB, 105 dB (A)
Output voltage impedance	REC OUT 1, 2, 3 ADAPTOR OUT	150 mV, 1 kohm
	HEADPHONES	25 milliwatts (at 8 ohms) Accepts low and high impedance headphones
Tone controls	BASS, at 100 Hz	-4 dB (turnover freq. 200 Hz)
		-5 dB (turnover freq. 400 Hz)
	TREBLE, at 10 kHz	-4 dB (turnover freq. 3 kHz)
		-5 dB (turnover freq. 5 kHz)
SUBSONIC filter	—	6 dB/octave attenuation below 15 Hz

General

System Preamplifier section: Low-noise FET high gain NFB type equalizer amplifier, passive type direct tone control
Power amplifier section: pure complementary SEPP power amplifier

Power requirements

US, Canadian Model: 120V AC, 60Hz
AEP, G-AEP Model: 220V AC, 50/60Hz
UK Model: 240V AC, 50Hz
E Model: 120, 220, or 240V AC adjustable, 50/60Hz

Power consumption

US Model: 330 watts
Canadian Model: 760VA
G-AEP Model: 390 watts
UK Model: 350 watts
AEP Model: 270 watts
E Model: 390 watts

AC outlets

US Canadian Model:
2 switched, total 100 watts max.,
2 unswitched, total 100 watts max.
AEP, G-AEP, UK Model: 1 switched, 100 watts max.
E Model: 1 switched, 100 watts max.

Dimensions

Approx. 430 x 160 x 436 mm (w/h/d)
(17 x 6 3/8 x 17 1/4 inches)

Weight

including projecting parts and controls
Approx. 18.3 kg (40 lbs 6 oz) net

FEATURES

Newly developed technologies assure excellent performance and tone quality

Pure sound

A head chassis, named "Gibraltar" which provides high rigidity and periodic damping characteristics, is employed to reduce distortion caused by vibrations. This reduces air vibrations caused by floor and speakers and also reduces vibrations caused by the power transformer and power transistors.

Spontaneous twin drive power circuit

Condensers having large capacity are used for the voltage amplification drive stage of class A and power output stage of class B. Thus, a stable output and high quality sound are obtained, resulting in exclusion of power interferences. The class A stage realizes a stable operation free from interference of the power stage even when an instantaneous or strong output is received.

Simple and direct tone control

The tone controls consist of only passive elements to minimize the deterioration of tone quality at the tone control circuit. Tone control elements can be passed by depressing the tone switch.

Source direct switch

A source direct switch is employed to reproduce high fidelity sound.

Any source can be reproduced without passing through the circuits of tone control, subsonic filter, mode switch and balance control.

Super legato linear system

The power amplifier drives low impedance speakers and assures powerful reproduction without low crossover distortion and switching distortion over the wide range. (Low impedance instantaneous service output 350 W + 350 W, 1 ohm loaded)

SAFETY CHECK-OUT (US Model)

After correcting the original service problem, perform the following safety check before releasing the set to the customer:

Check the antenna terminals, metal trim, "metallized" knobs, screws, and all other exposed metal parts for AC leakage. Check leakage as described below.

LEAKAGE TEST

The AC leakage from any exposed metal part to earth ground and from all exposed metal parts to any exposed metal part having a return to chassis, must not exceed 0.5 mA (500 microamperes). Leakage current can be measured by any one of three methods.

1. A commercial leakage tester, such as the Simpson 229 or RCA WT-540A. Follow the manufacturers' instructions to use these instruments.
2. A battery-operated AC milliammeter. The Data Precision 245 digital multimeter is suitable for this job.
3. Measuring the voltage drop across a resistor by means of a VOM or battery-operated AC voltmeter. The "limit" indication is 0.75 V, so analog meters must have an accurate low-voltage scale. The Simpson 250 and Sanwa SH-63Trd are examples of a passive VOM that is suitable. Nearly all battery operated digital multimeters that have a 2V AC range are suitable. (See Fig. A)

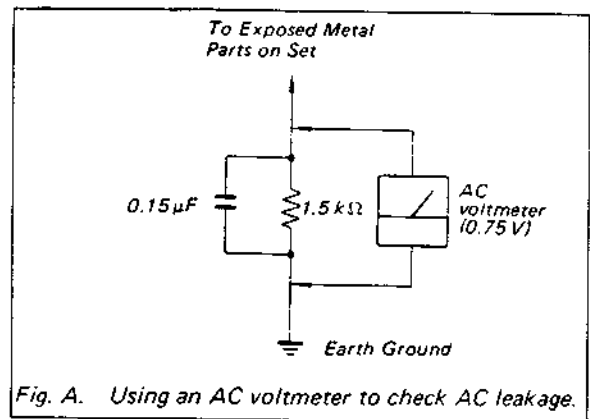
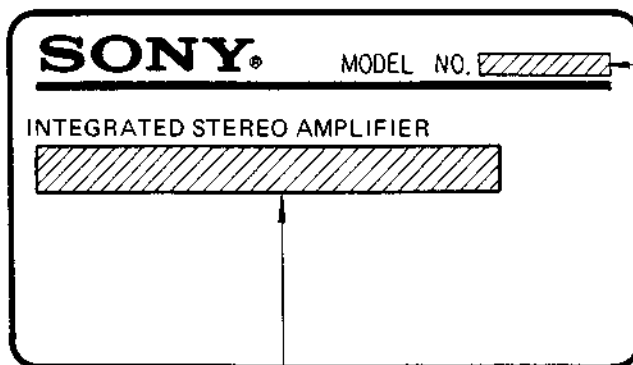

Fig. A. Using an AC voltmeter to check AC leakage.

MODEL IDENTIFICATION

— Specification Label —



- E Model: TA-F444ESX
- US Model: TA-F700ES
- Canadian Model: TA-F700ES
- AEP Model: TA-F700ES
- UK Model: TA-F700ES
- G-AEP Model: TA-F700ES

US Model	: AC120V	60Hz	330W
Canadian Model	: AC120V	60Hz	760VA
AEP Model	: AC220V	50/60Hz	270W
G-AEP Model	: AC220/240V	50/60Hz	390W
UK Model	: AC220/240V	50/60Hz	350W
E Model	: AC120/220/240V	50/60Hz	390W

TABLE OF CONTENTS

<u>Title</u>	<u>Description</u>	<u>Page</u>
	Specifications	1
	Features	2
	Safety Check-out (US Model)	3
	Model Identification	3
	Function of Controls	5
	Note on Repairing	
	Disassembly and Assembly for Switch Section.	8
Section 1.	Block Diagram	9
Section 2.	Disassembly	11
Section 3.	Adjustments.	14
Section 4.	Diagrams	
4-1.	Mounting Diagram.	15
4-2.	Schematic Diagram	19
Section 5.	Exploded Views and Parts List.	23
Section 6.	Electrical Parts List	27

FUNCTION OF CONTROLS

Front panel / Panneau avant / Vorderseite / Panel frontal / Voorpaneel

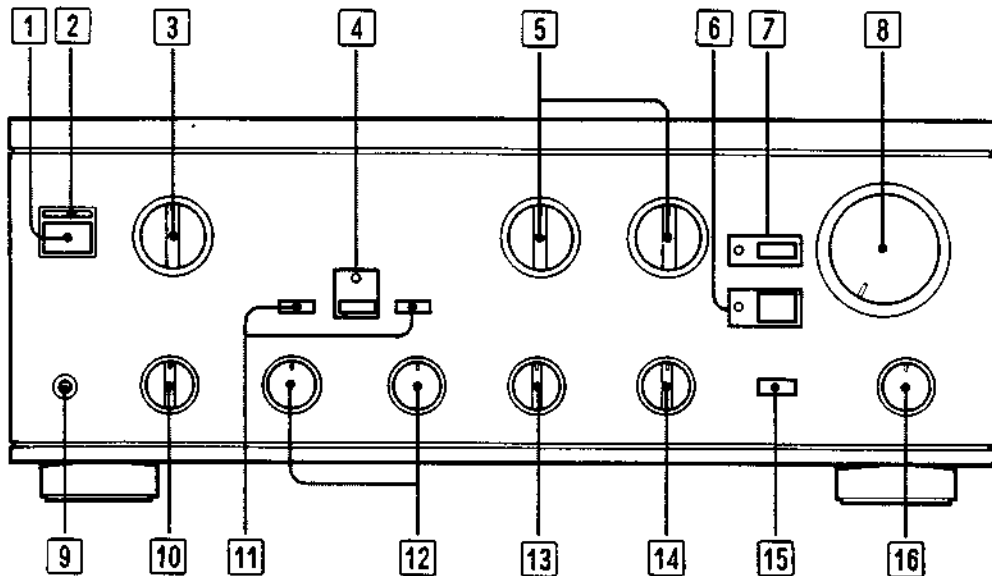

Rear panel / Panneau arrière / Rückseite / Panel posterior / Achterpaneel

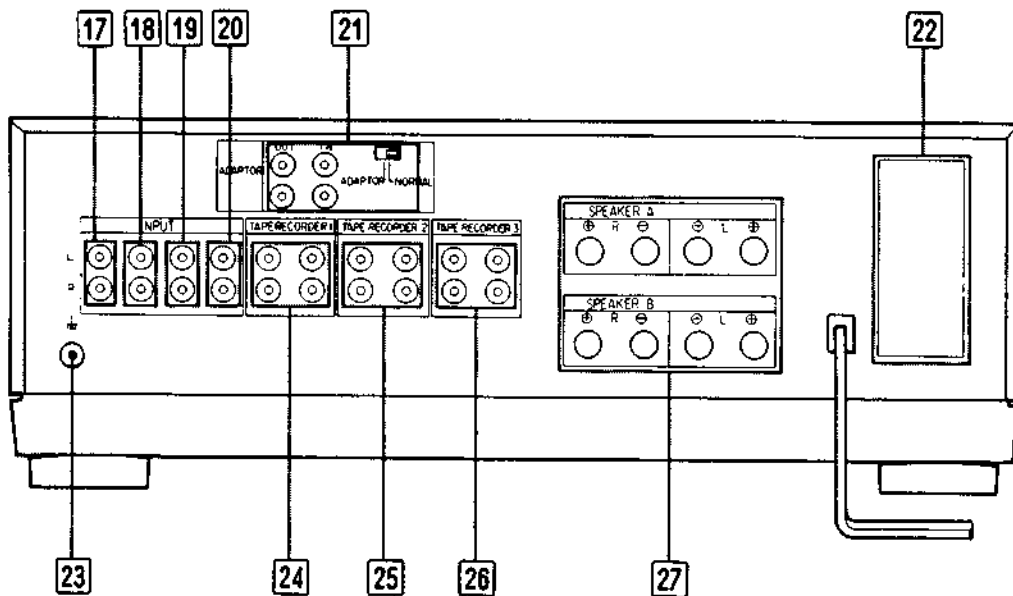

TA-F444ESX/F700ES

Front panel

1 POWER switch

2 Power/standby indicator

Immediately after turning ON the power, the standby indicator lights in red as the built-in muting circuit activates.

When the amplifier stays in a stable operating condition, the indicator lights in green.

The indicator lights in red when the unit detects shorting of circuit of the speaker outputs or in case of short-circuit of the inputs of DC components.

In such a case, disconnect the power source and check the connected components and speaker systems.

3 SPEAKERS selector

Select speaker system A or B, or both.

For headphone monitoring only, set the selector to OFF.

4 TONE switch and indicator

Depress the switch to activate the tone control circuit. Red indicator lights.

5 INPUT SELECTOR and TAPE input selector

To select the desired program source, use the INPUT SELECTOR.

To select TAPE 1, 2 or 3, set the INPUT SELECTOR to TAPE and set the TAPE input selector to the desired tape input position.

6 SOURCE DIRECT switch and indicator

Depress the switch. The red indicator lights and the circuits of the TONE switch, SUBSONIC filter switch, BALANCE control and MODE switch are disengaged without regard to the setting of the switches.

When this switch is activated, the indicator of the TONE switch does not light.

7 MUTING switch and indicator

Generally, keep the switch released (OFF).

Depress the switch to reduce the sound level by 20dB. (Output voltage becomes 1/10.)

8 ATTENUATOR knob

Regulates the sound level.

9 HEADPHONES jack (stereo phone jack)

10 MODE selector

STEREO: For listening to a stereo program.

MONO: For listening to a monaural program.

11 TURNOVER frequency selection switches

Switch the turnover frequency.

12 BASS and TREBLE controls

These controls activate when the TONE switch is depressed.

13 REC OUT SELECTOR

Selects the program source sent to the REC OUT jacks (rear panel).

14 CARTRIDGE LOAD selector

Set the selector according to your cartridge.

MM: For moving-magnet type cartridge

MC: For moving-coil type cartridge

40 Ω : For a cartridge with an impedance of 40 ohms or more.

3 Ω : For a cartridge with an impedance of 3 ohms to 40 ohms.

15 SUBSONIC filter switch

Depress the switch to reduce unwanted noise components of less than 15Hz, which cause modulation noise.

16 BALANCE control

Controls the sound level of left and right speakers.

Rear panel**17 PHONO input jacks****18 TUNER input jacks****19 CD (Compact Disc) input jacks****20 AUX (Auxiliary) input jacks****21 ADAPTOR IN/OUT (input and output) jacks and adaptor switch**

The OUT jacks output the signals selected by the INPUT SELECTOR on the front panel and the IN jacks receive the signals.

When an additional equipment such as a graphic equalizer is connected, set the adaptor switch to ADAPTOR.

When the jacks are not used, set the switch to NORMAL.

22 AC OUTLET(s) and VOLTAGE SELECTOR (E Model)

The AC OUTLET is used to power other audio components whose total power consumption is less than the wattage indicated near the AC OUTLET.

23 Ground terminal ⏏

To prevent hum, be sure to connect the ground wire of the turntable system to this ground terminal. If hum still exists, it may be helpful to connect the ground terminal directly to earth via a ground rod.

Note

In some particular MM cartridges, the ground for signal is connected to the ground for cartridge body.

If this type of cartridge should be installed to a metal cartridge shell, current will flow through the tonearm ground in a loop and will cause hum noise. In this case, disconnect the turntable ground wire from the ⏏ terminal of the amplifier, or disconnect the ground for cartridge body from the ground for signal.

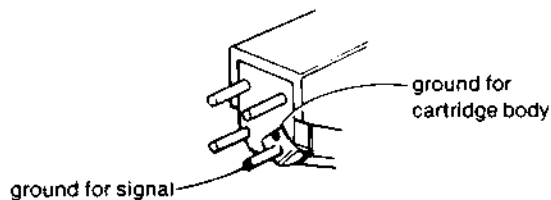
**24 25 26 TAPE RECORDER 1, 2, 3 input/output jacks**

REC OUT (recording output) jacks: Accept the tape input jacks of the tape recorder.

To connect a hi-fi video cassette recorder, connect the audio line input jacks of the video cassette recorder to these jacks.

TAPE (tape input) jacks: Accept the REC output jacks of the tape recorder.

To connect a hi-fi video cassette recorder, video disc player or TV tuner, connect the audio line output jacks of each equipment to these jacks.

27 SPEAKER output terminals

Two pairs of speaker systems can be connected.

System A, system B or system A and B can be selected by means of the front panel SPEAKERS selector.

NOTE ON REPAIRING DISASSEMBLY AND ASSEMBLY FOR SWITCH SECTION

Note: Follow the assembly procedure in the numerical order given.

DISASSEMBLY

Insert in the screwdriver and remove the wiring as illustrated below
CAUTION: Don't pull the wiring. It causes the wiring damage.

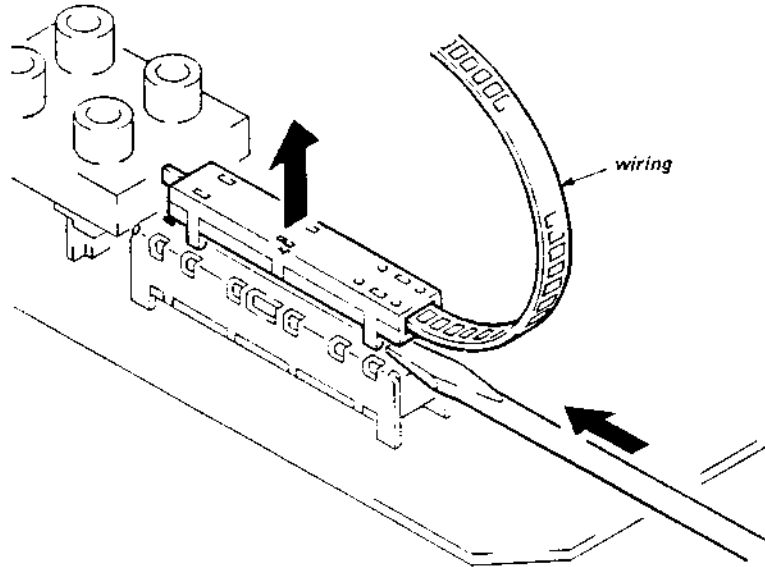

ASSEMBLY

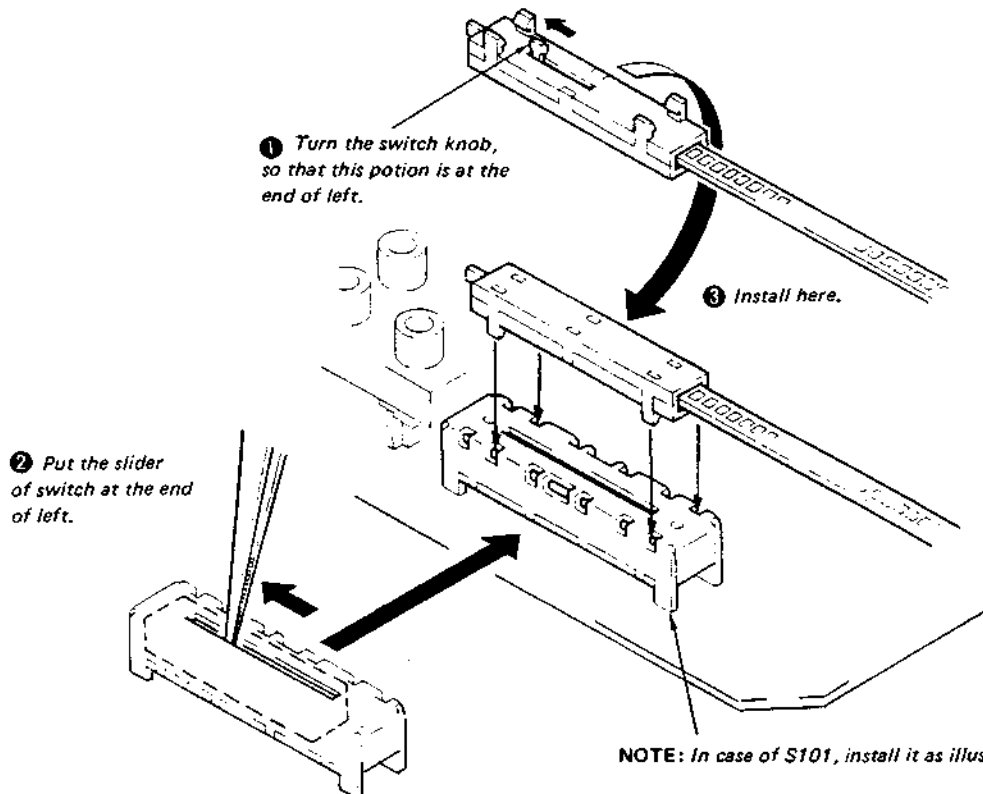

TA-F44ESX/F700ES TA-F44ESX/F700ES

SECTION 1
BLOCK DIAGRAM

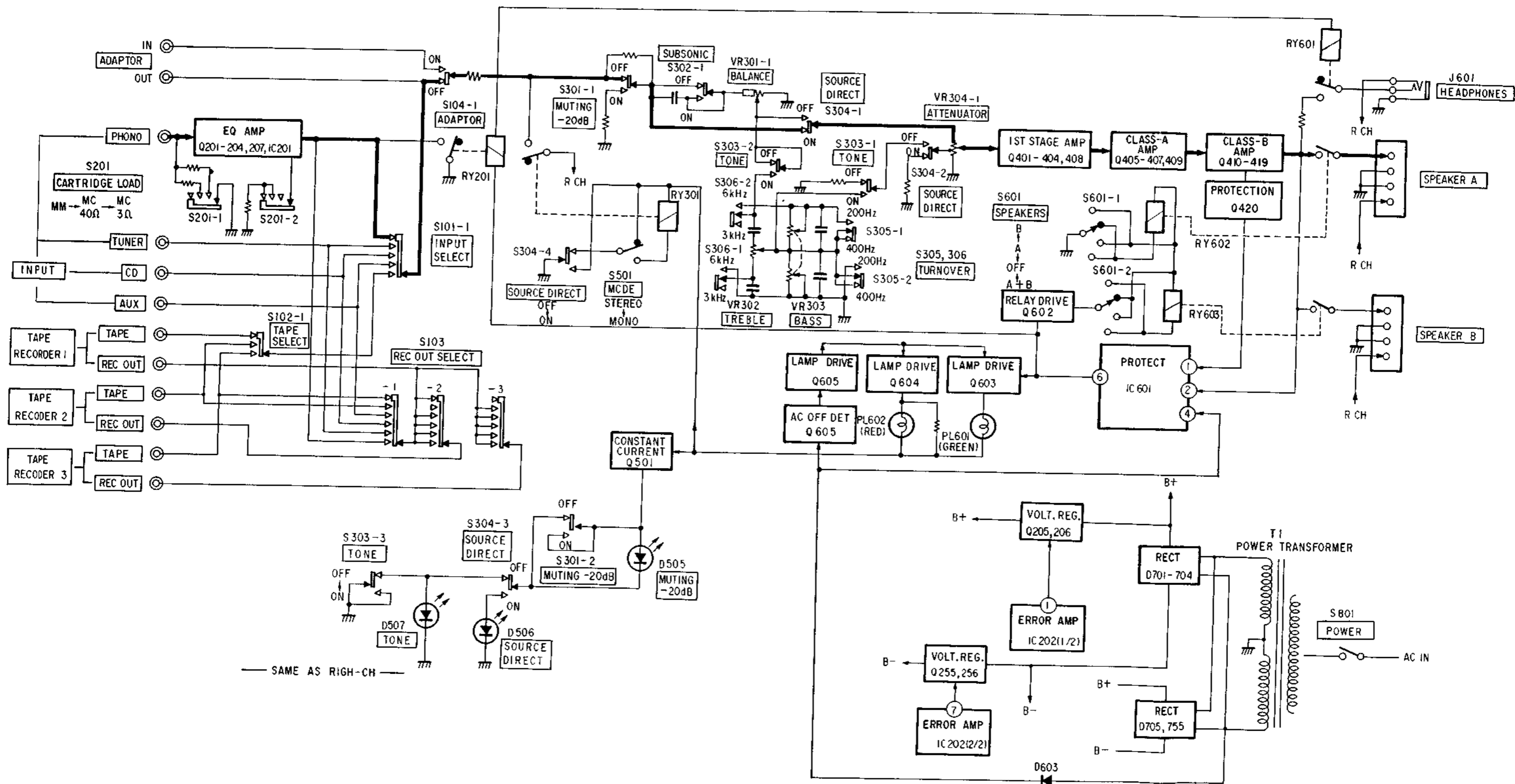

**SECTION 2
DISASSEMBLY**

Note: Follow the disassembly procedure in the numerical order given.

TOP COVER AND BOTTOM PLATE REMOVAL

TOP COVER : ①~④

BOTTOM PLATE : ①~③

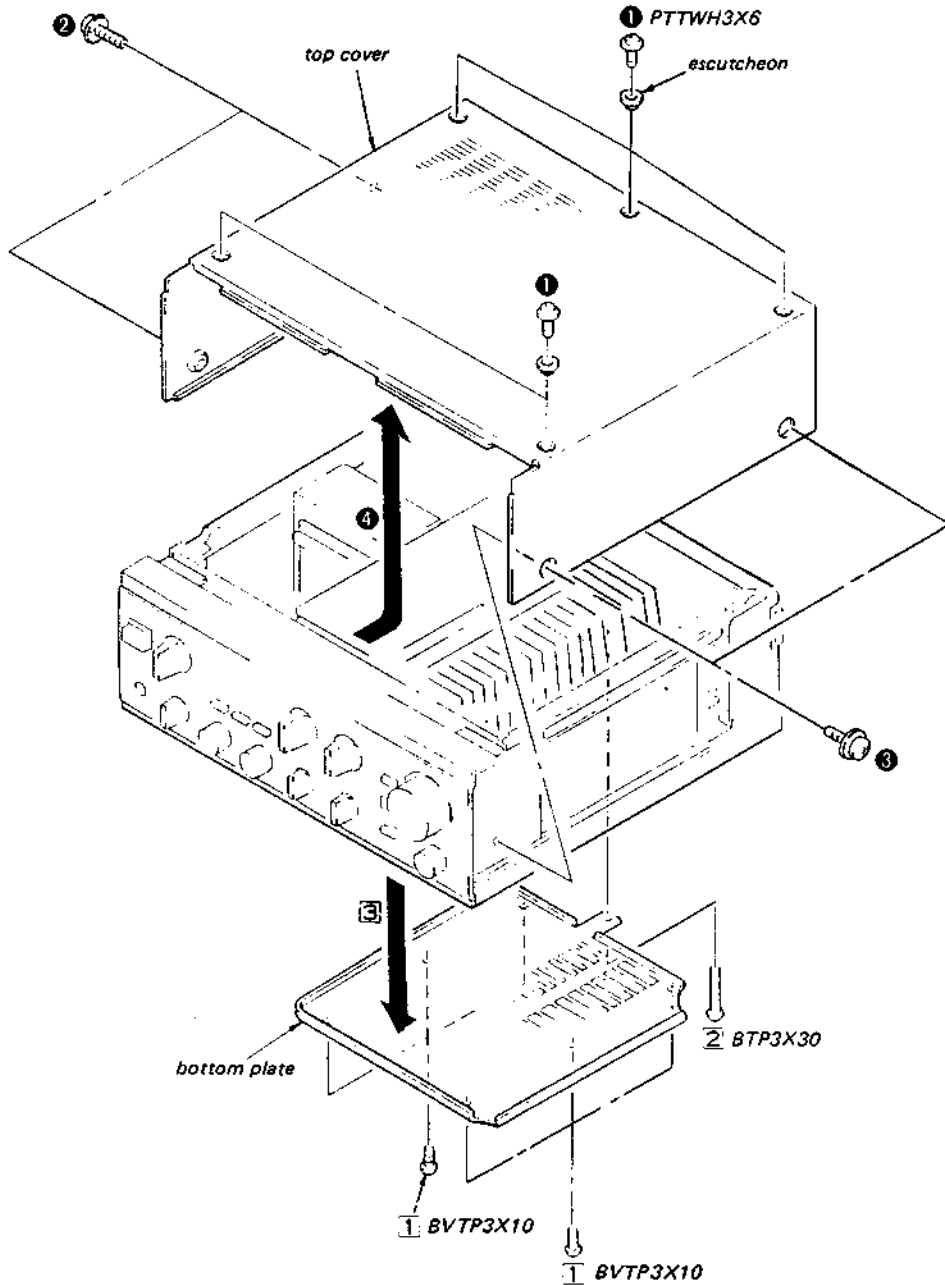

FRONT PANEL REMOVAL

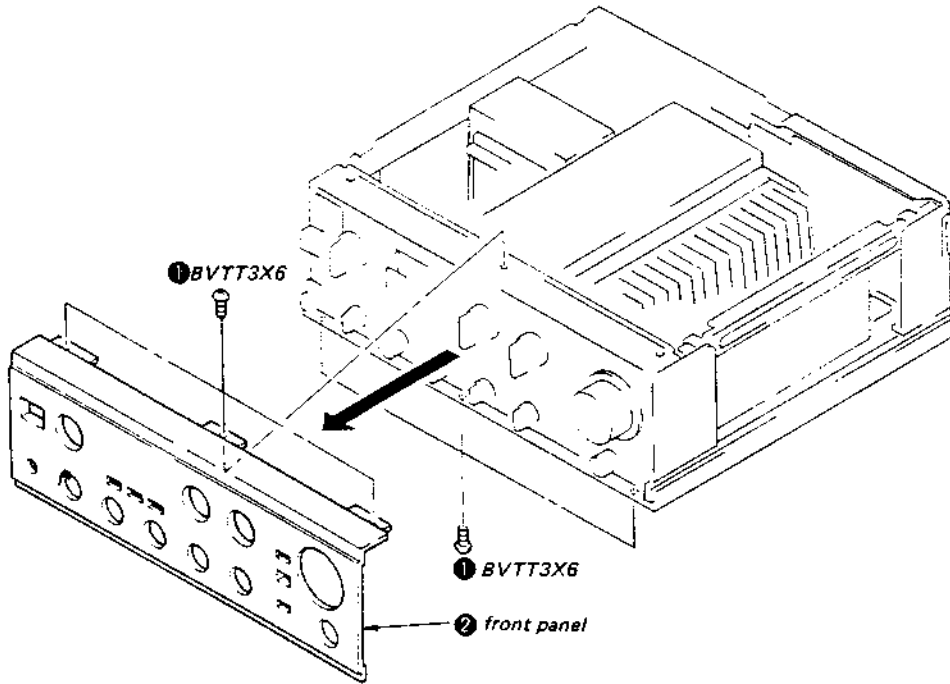

JACK PLATE REMOVAL

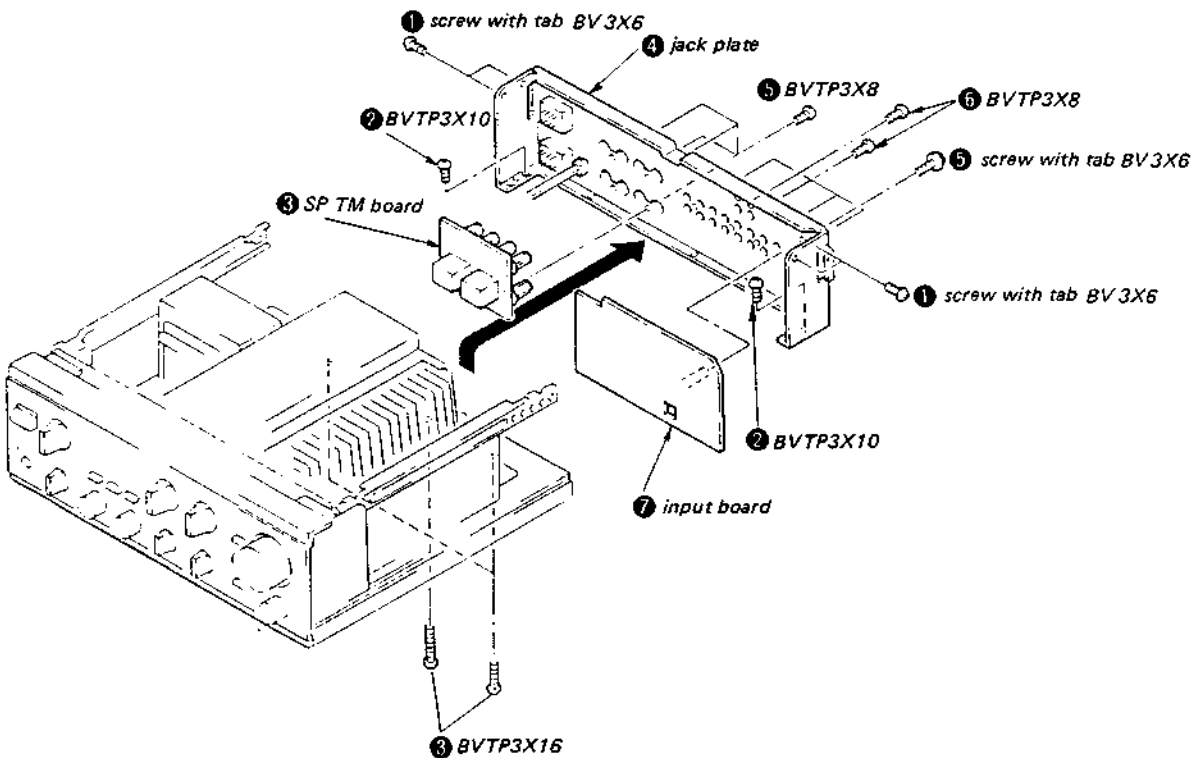

MAIN BOARD REMOVAL

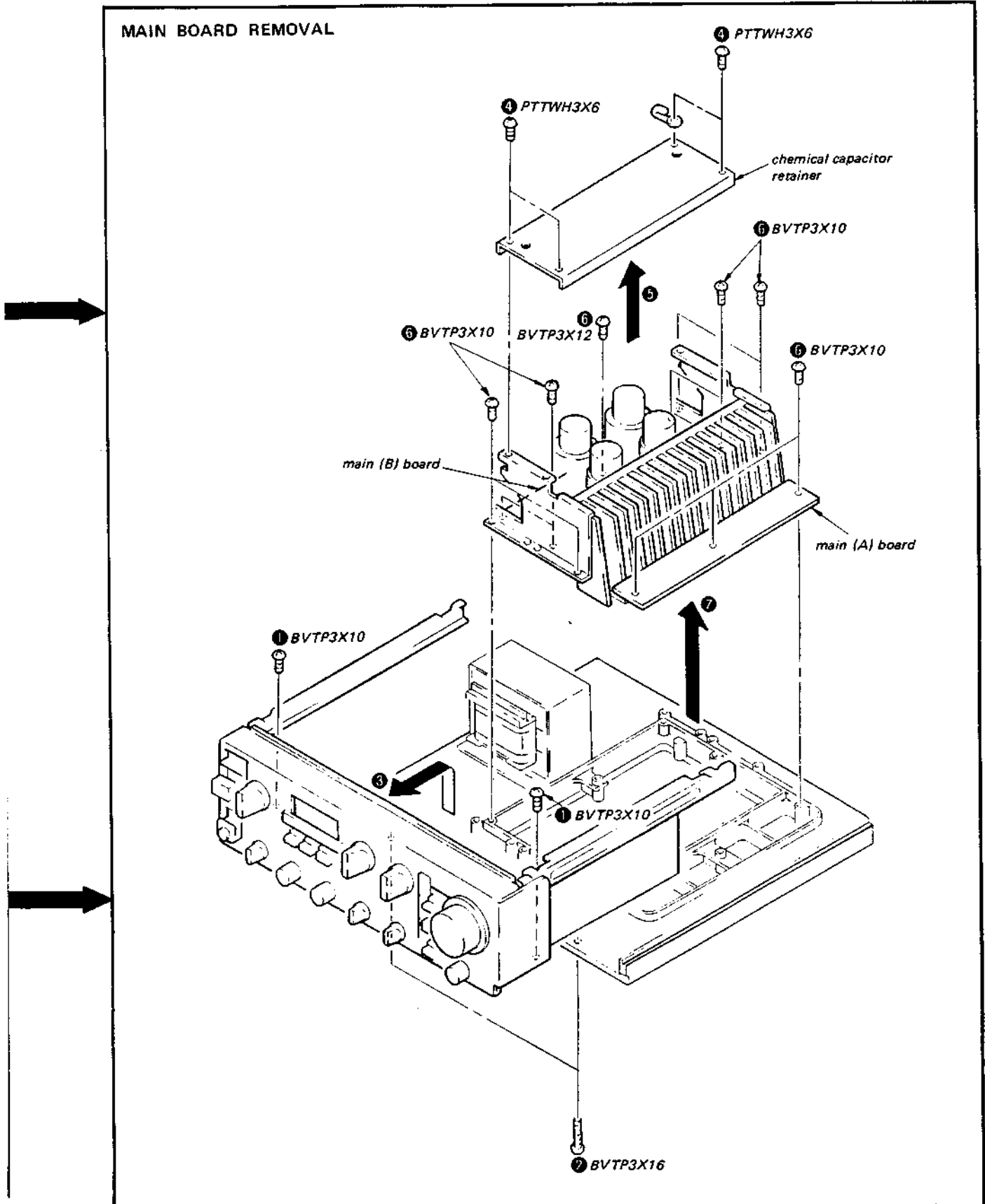

SECTION 3 ADJUSTMENTS

NOTE:

- Adjustments should be performed 10 minutes after the POWER switch is on (POWER ON).

OFFSET Adjustment

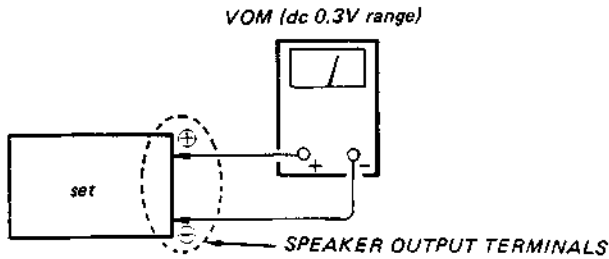

1. Turn the ATTENUATOR knob fully counterclockwise under no-signal conditions.
2. Adjust RT401 and RT451 for 0V readings VOM.

DC BIAS Adjustment

1. Turn the ATTENUATOR knob fully counterclockwise under no-signal conditions.
2. Adjust RT402 and RT452 for 15mV readings on VOM.

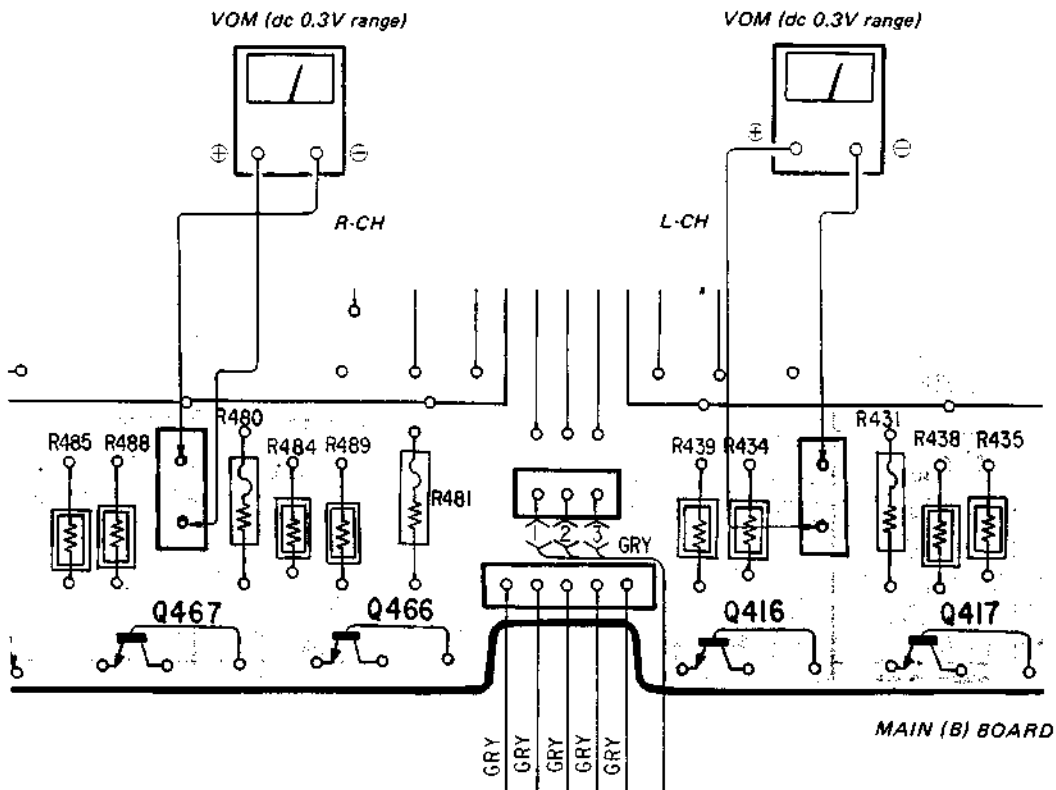

1 2 3 4 5 6 7 8 9 10 11 12 13

SECTION 4
DIAGRAMS

• SEMICONDUCTOR LEAD LAYOUTS

<p>M5218P M5220P NJM5532D-D</p>	<p>2SA995</p>	<p>2SB734</p>
<p>UPC1237H</p>	<p>2SA988-F 2SB647 2SC1841-PA</p>	<p>2SA1142 2SB731 2SD668 2SD809</p> <p>MARKING SIDE VIEW</p>
<p>CTU22R CTU22S</p>	<p>2SK246GR2</p>	<p>2SK170</p>
<p>ISS132</p>	<p>2SA1027R</p>	
<p>30DF2 EQ801-12Z</p>	<p>2SC634SP</p>	
<p>10E2 HZ6C3L HZ7B2L HZ9B2L HZ11A1L HZ15-3L</p>	<p>2SA985A 2SA1383 2SB1094-L 2SC3514 2SC2275-P</p>	
<p>SV-02 SV-03</p>	<p>2SA1186 2SC2837</p>	
<p>SEL2810A</p>	<p>2SK389-GR</p>	

A
B
C
D
E
F
G
H
I
J

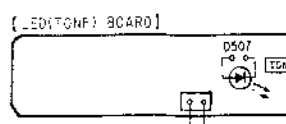
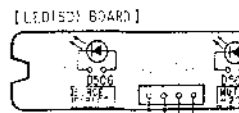
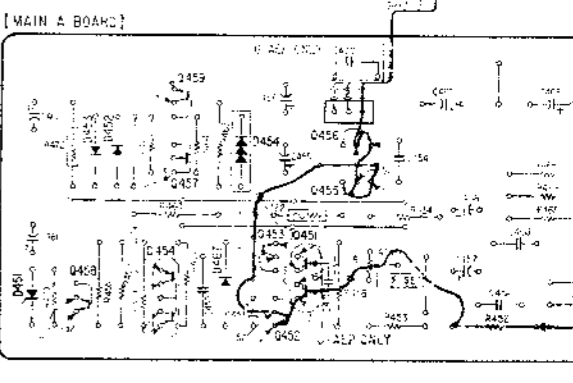
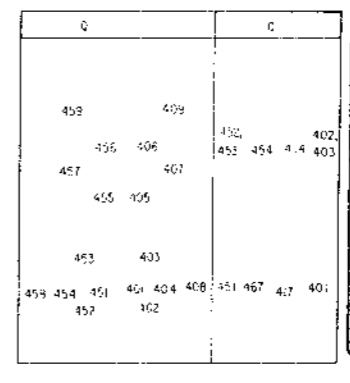
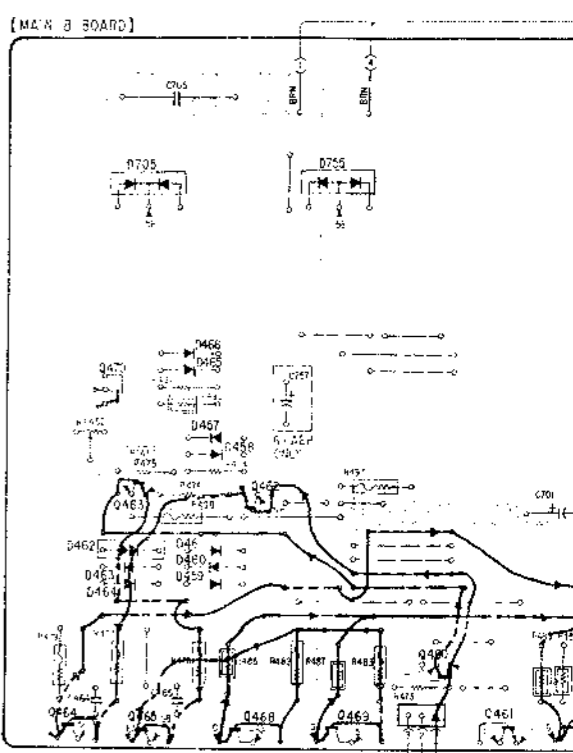
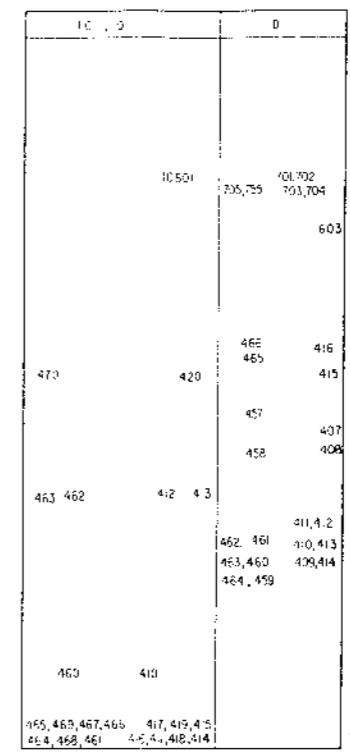
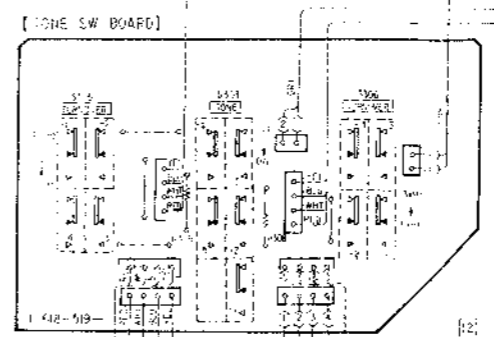
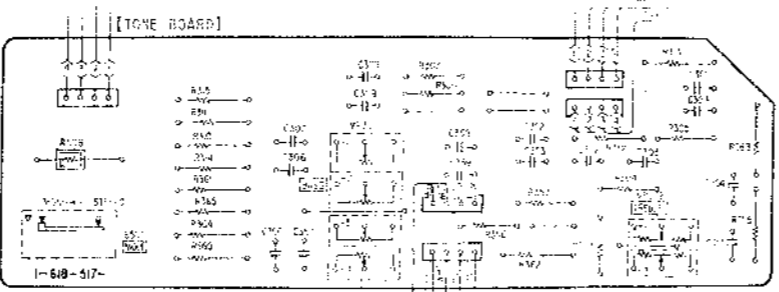
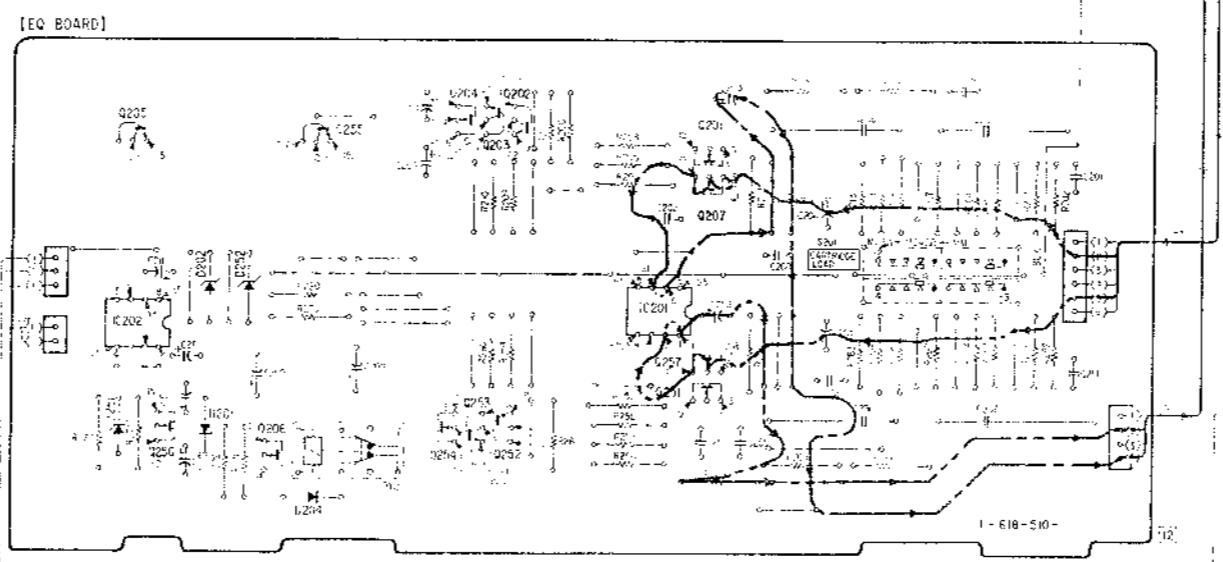
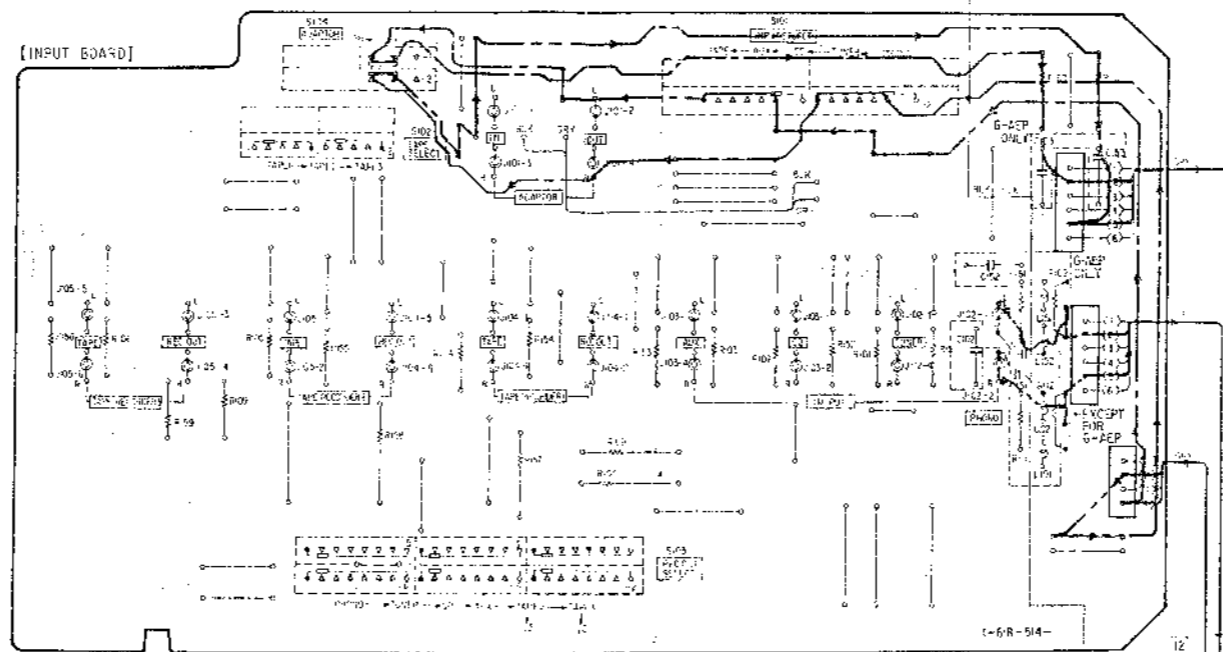

A

B

C

D

E

F

G

H

I

J

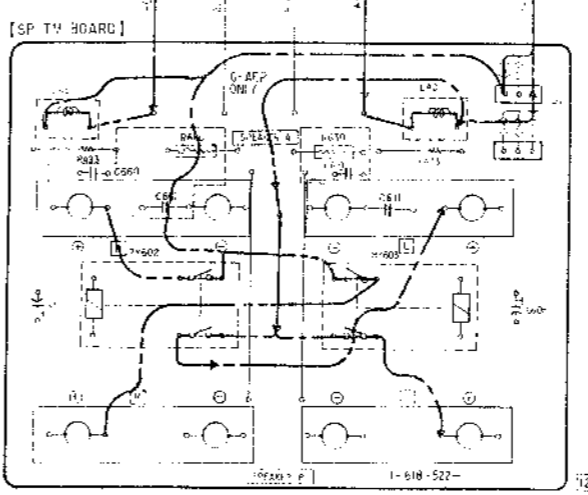
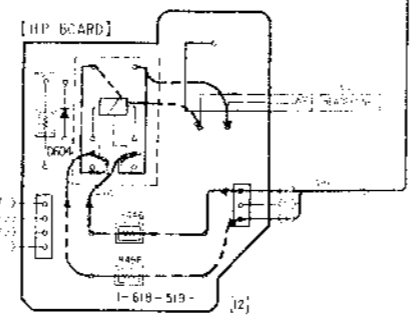
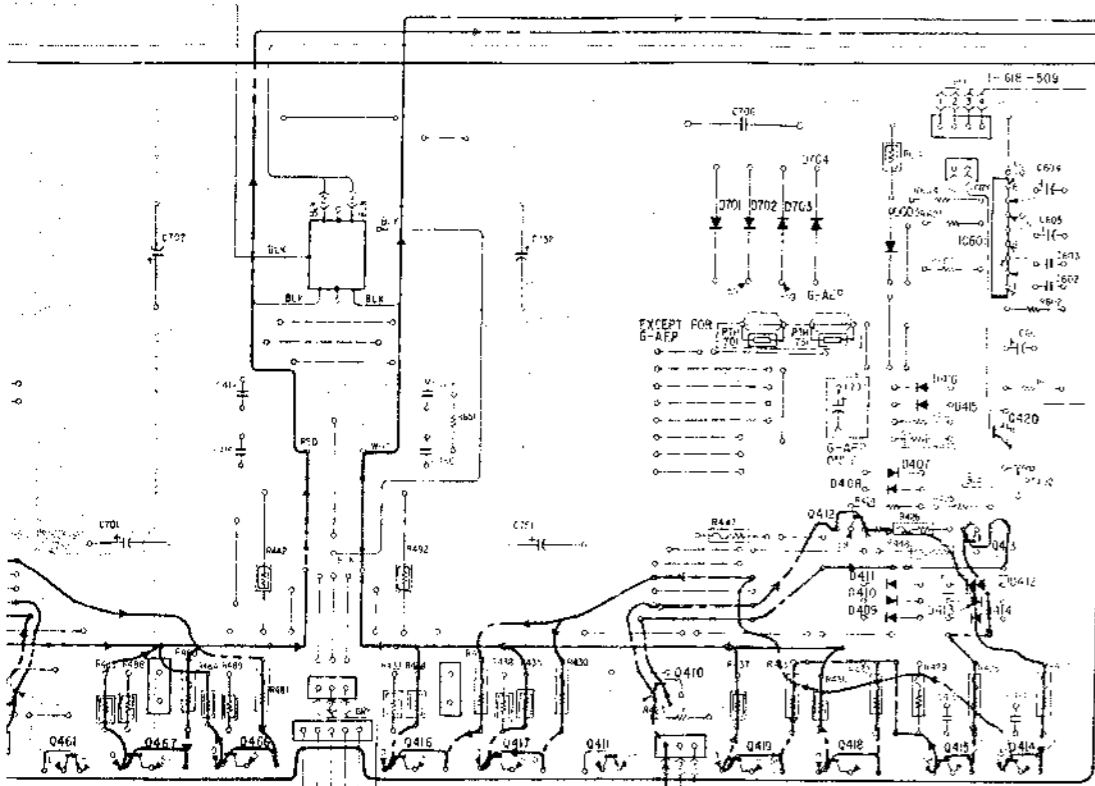

Note on Mounting Diagram

- : signal path
- : L-CH signal path
- : R-CH signal path

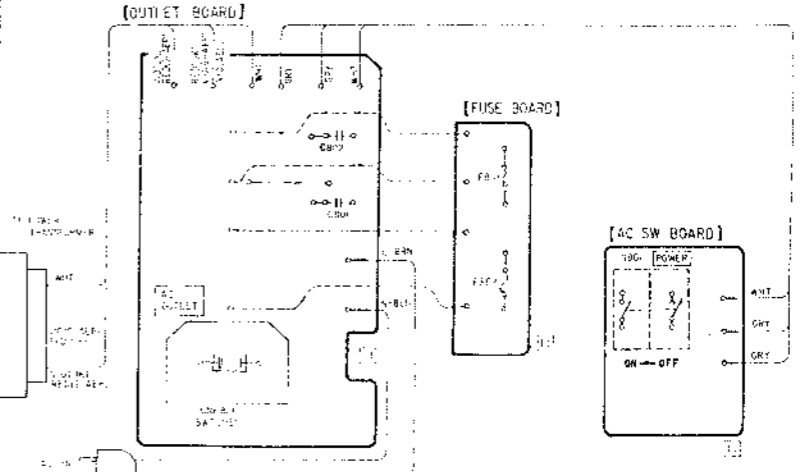
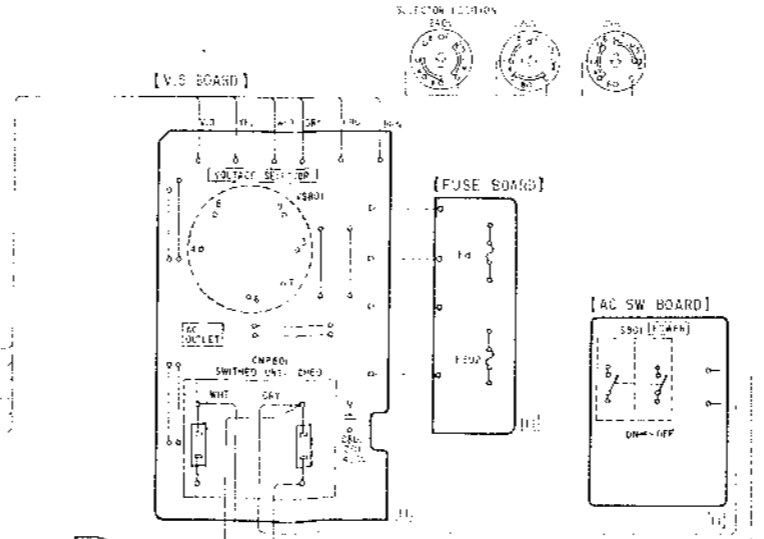
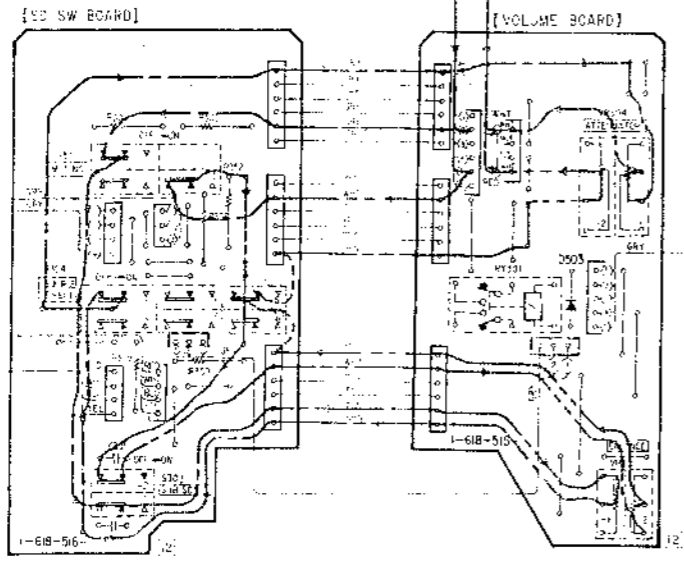
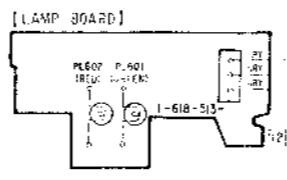
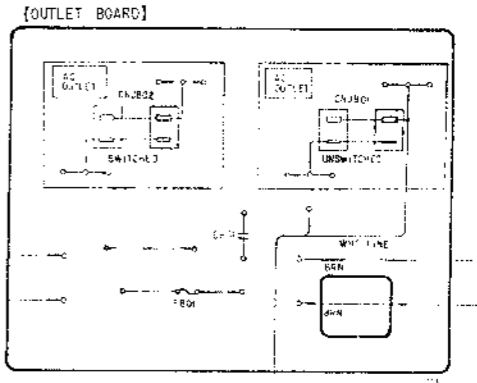
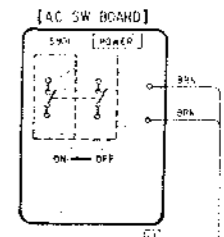
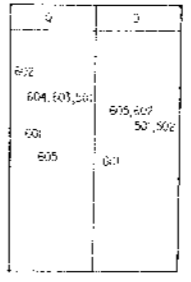
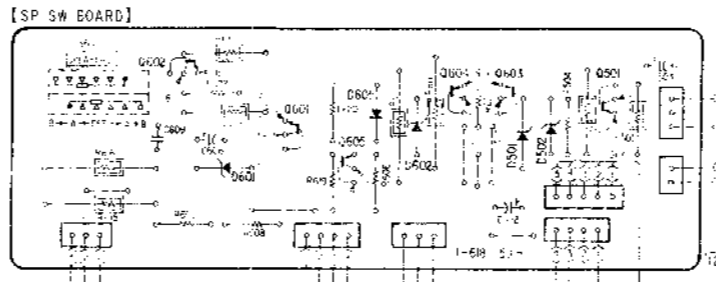
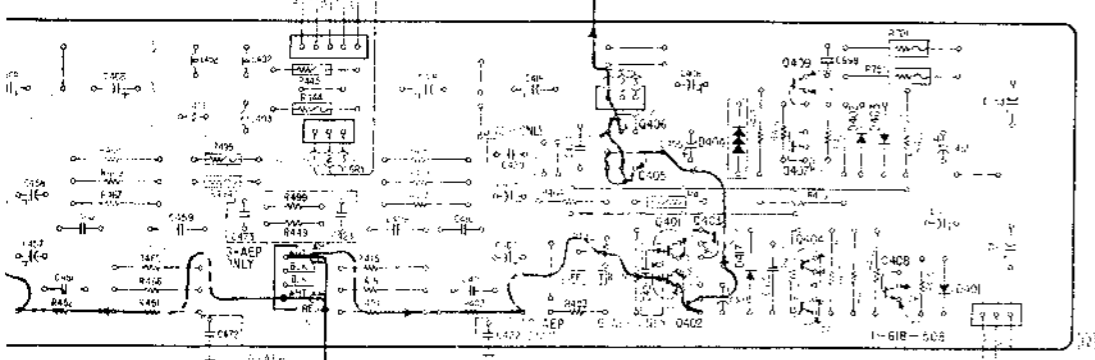

TA-F444ESX/F700ES TA-F444ESX/F700ES

4.2. SCHEMATIC DIAGRAM

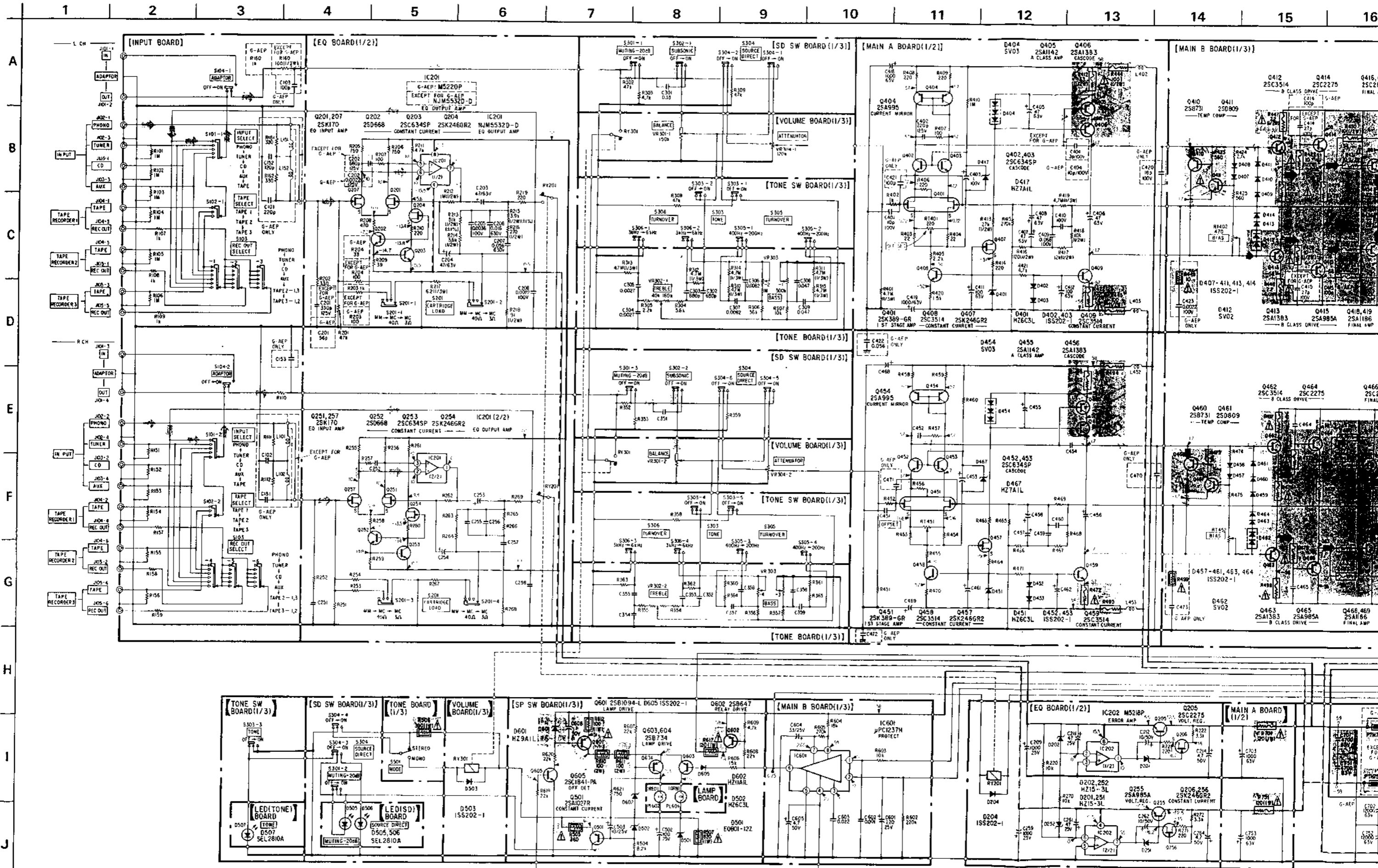

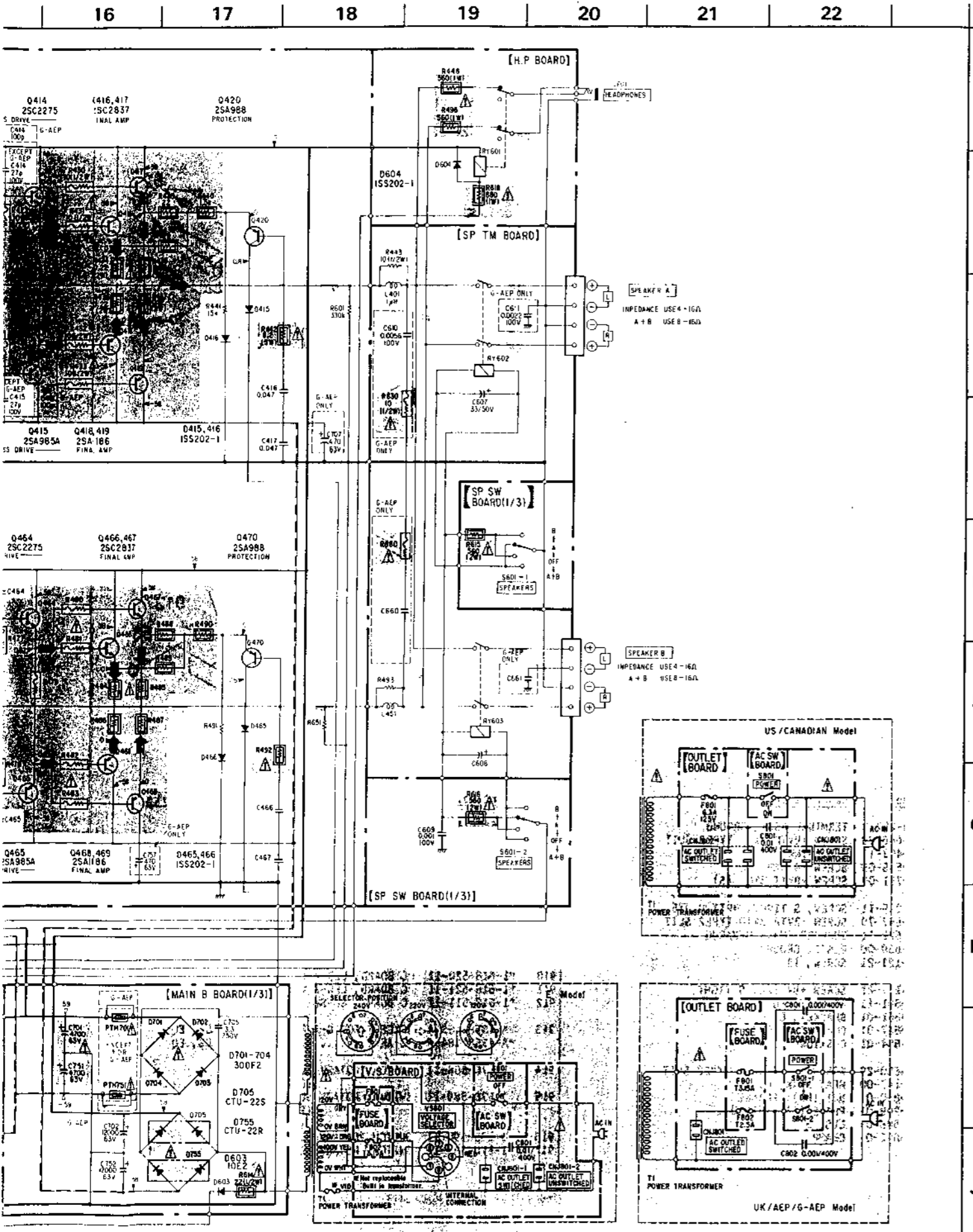

Note on Schematic Diagram

Note:

- All capacitors are in μF unless otherwise noted. pF : $\mu\mu\text{F}$
50 WV or less are not indicated except for electrolytics and tantalums.
- All resistors are in Ω and $\frac{1}{4}\text{W}$ or less unless otherwise specified.
- \square : signal path.

Note: The components identified by shading and mark \triangle are critical for safety. Replace only with part number specified.

Note: Les composants identifiés par une trame et une marque \triangle sont critiques pour la sécurité. Ne les remplacer que par une pièce portant le numéro spécifié.

- Components for right channel have same values as for left channel.
- \square : nonflammable resistor.
- \square : fusible resistor.
- Switch

Ref. No.	Switch	Position
S101	INPUT SELECT	PHONE
S102	TAPE SELECT	TAPE 1
S103	REC OUT SELECT	PHONO
S104	ADAPTOR	OFF
S201	CARTRIDGE LOAD	MM
S301	MUTING -20dB	OFF
S302	SUBSONIC	OFF
S303	TONE	OFF
S304	SOURCE DIRECT	OFF
S305	TURN OVER	400Hz
S306	TURN OVER	3kHz
S501	MODE	STEREO
S601	SPEAKER	A
S801	POWER	OFF
VS809	VOLTAGE SELECTOR (E MODEL)	-

- \square : B+ bus.
- \square : B- bus.
- \square : adjustment for repair.
- Voltages are dc with respect to ground unless otherwise noted
- Readings are taken under no-signal conditions with a VOM (50 k Ω /V).
- Voltage variations may be noted due to normal production tolerances.

• CIRCUIT BOARDS LOCATION

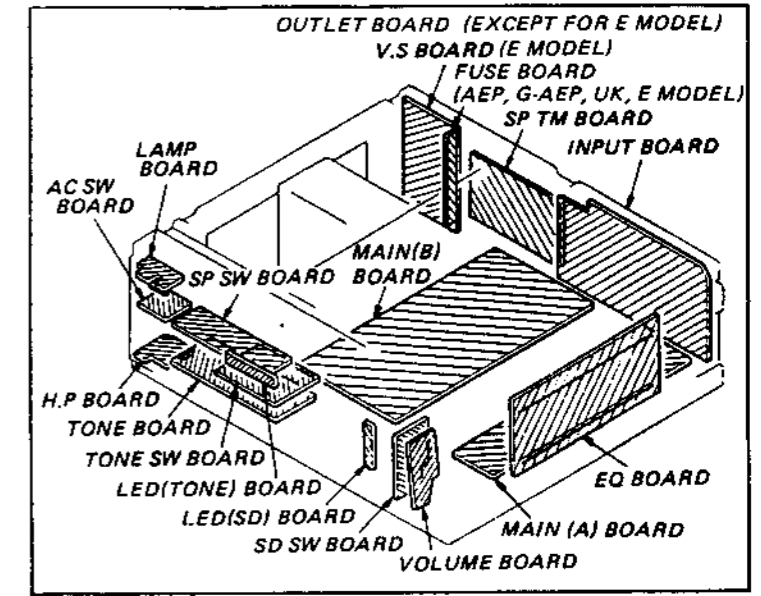

IC BLOCK DIAGRAM

$\mu\text{PC1237H}$

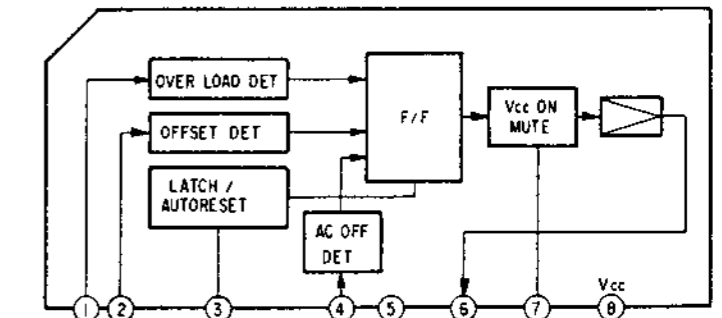

TA-F444ESX/F700ES TA-F444ESX/F700ES

4-2. SCHEMATIC DIAGRAM

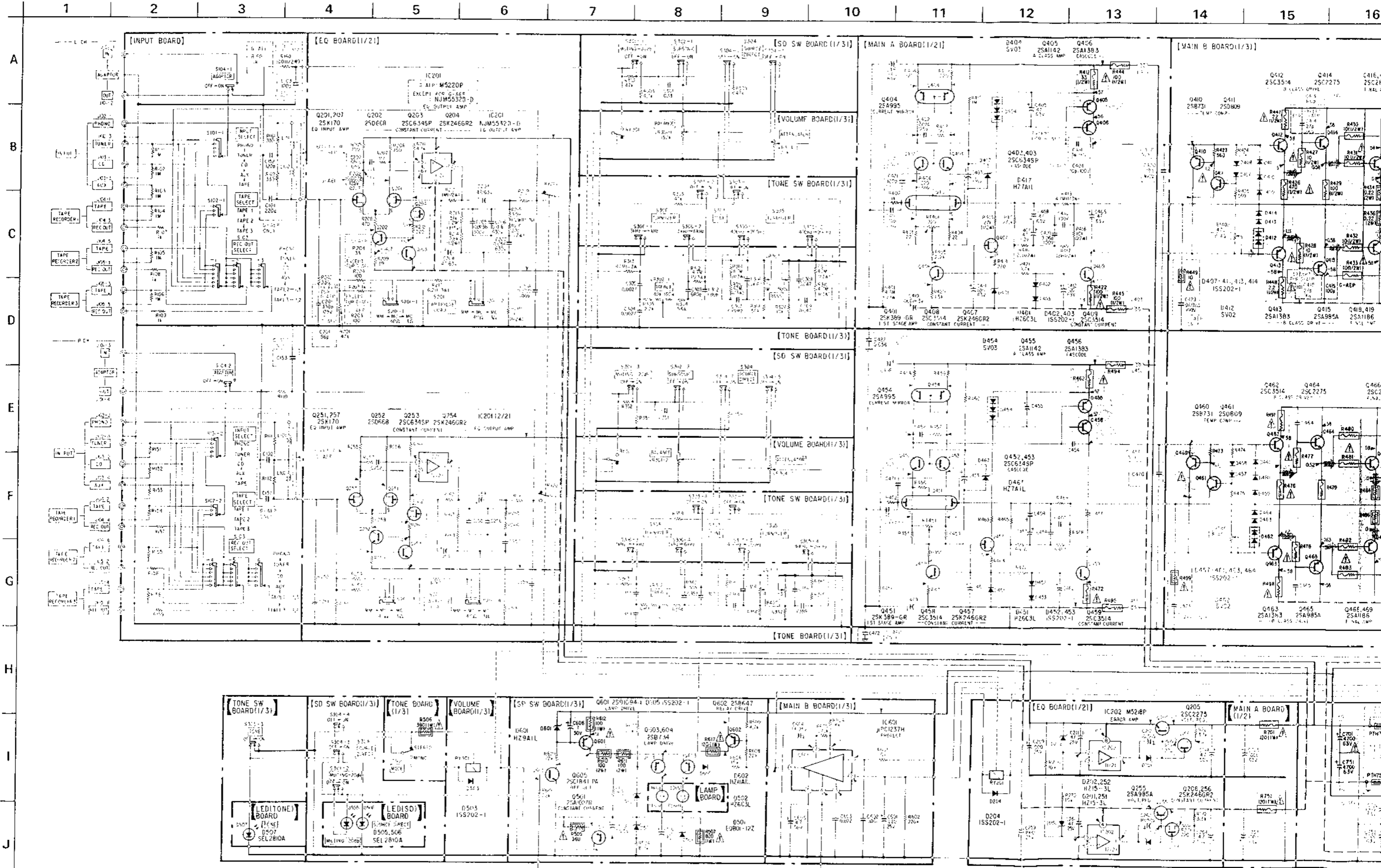

16 17 18 19 20 21 22

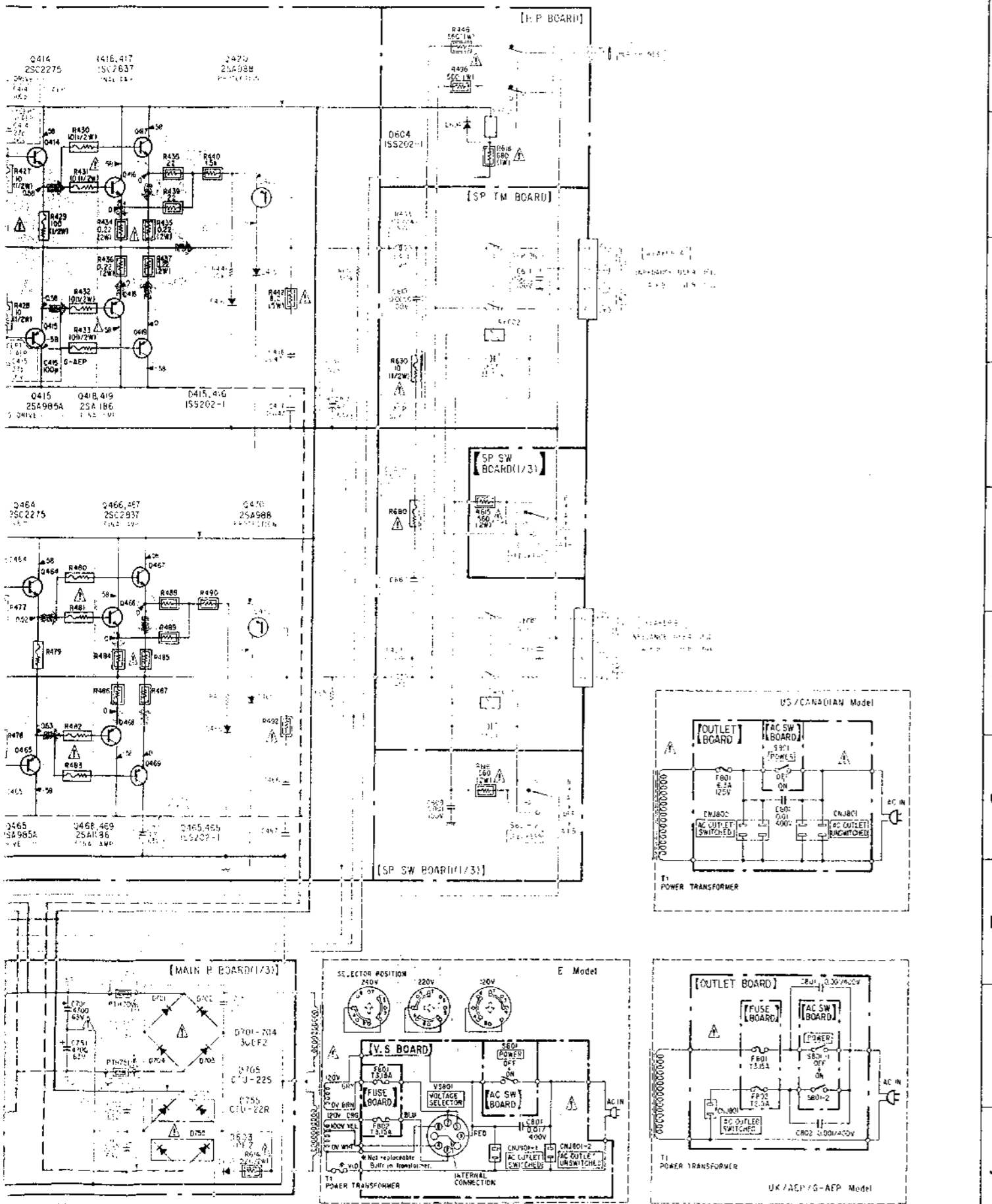

Note on Schematic Diagram

Note:

- All capacitors are in μF unless otherwise noted. pF : μF
- 50 WV or less are not indicated except for electrolytics and tantalums.
- All resistors are in Ω and $1/4\text{W}$ or less unless otherwise specified.
- \square : signal path.

Note: The components identified by shading and mark Δ are critical for safety. Replace only with part number specified.

Note: Les composants identifiés par une trame et une marque Δ sont critiques pour la sécurité. Ne les remplacer que par une pièce portant le numéro spécifié.

- Components for right channel have same values as for left channel.
- \square : nonflammable resistor.
- \square : fusible resistor.
- Switch

Ref. No.	Switch	Position
S101	INPUT SELECT	PHONE
S102	TAPE SELECT	TAPE 1
S103	REC OUT SELECT	PHONO
S104	ADAPTOR	OFF
S201	CARTRIDGE LOAD	MM
S301	MUTING - 20dB	OFF
S302	SUBSONIC	OFF
S303	TONE	OFF
S304	SOURCE DIRECT	OFF
S305	TURN OVER	400Hz
S306	TURN OVER	3kHz
S501	MODE	STEREO
S601	SPEAKER	A
S801	POWER	OFF
VS809	VOLTAGE SELECTOR (E MODEL)	-

- \square : H + bus.
- \square : B - bus.
- \square : adjustment for repair.
- Voltages are dc with respect to ground unless otherwise noted.
- Readings are taken under no signal conditions with a VOM (50 kHz/V).
- Voltage variations may be noted due to normal production tolerances.

CIRCUIT BOARDS LOCATION

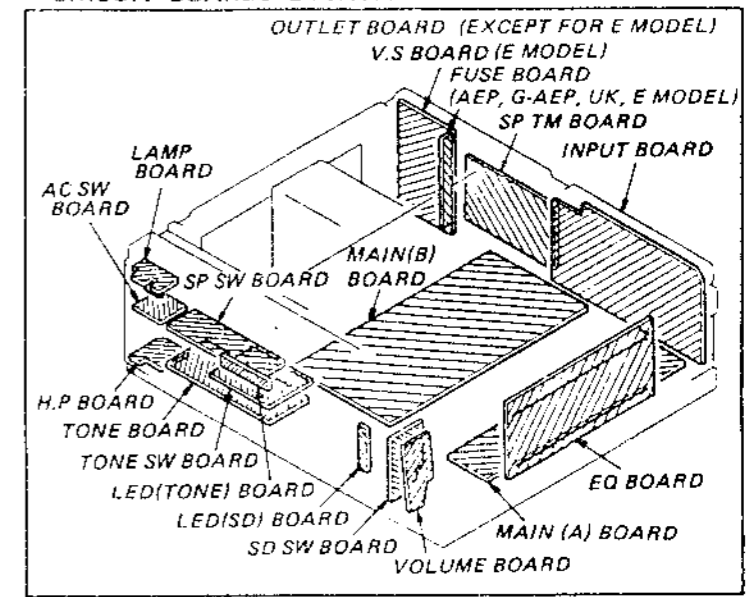

IC BLOCK DIAGRAM

$\mu\text{PC1237H}$

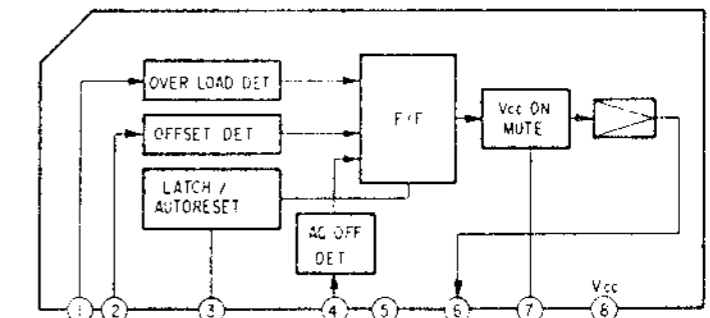

SECTION 5 EXPLODED VIEWS AND PARTS LIST

NOTE:

- The mechanical parts with no reference number in the exploded views are not supplied.
- Items marked "*" are not stocked since they are seldom required for routine service. Some delay should be anticipated when ordering these items.
- The construction parts of an assembled part are indicated with a collation number in the remark column.

The components identified by shading and mark  are critical for safety. Replace only with part number specified.

Les composants identifiés par une trame et une marque  sont critiques pour la sécurité. Ne les remplacer que par une pièce portant le numéro spécifié.

(1)

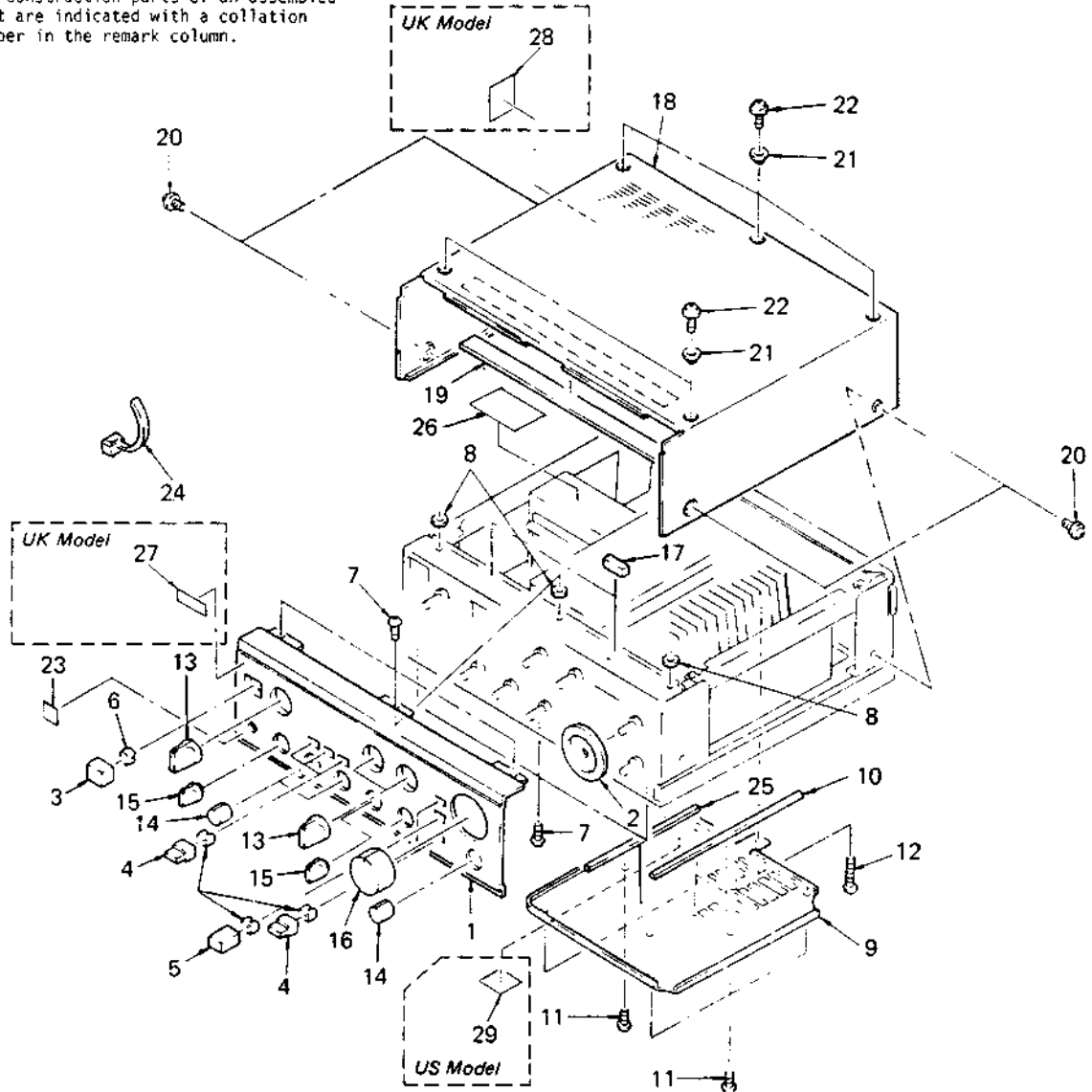

No.	Part No.	Description	Remarks	No.	Part No.	Description	Remarks
1	A-4322-860-A A-4322-872-A	(EXCEPT FOR E)...PANEL ASSY, FRONT (E)...PANEL ASSY, FRONT		16	4-916-705-01 4-916-705-01	(EXCEPT FOR E)...KNOB (NA-48), R (E)...KNOB (NA-48), R	
2	4-908-857-01	RING (DIA.48), ORNAMENTAL		17	*4-908-872-01	CUSHION	
3	4-908-856-01	KNOB, SQUARE		18	4-908-868-01	CASE	
4	3-315-105-21	KNOB (5X16), SQUARE		19	4-916-782-01	DAMPER	
5	4-908-875-01	KNOB, SQUARE		20	4-849-802-00	SCREW	
6	4-864-307-00	RING		21	3-576-290-11	ESCUTCHEON	
7	7-685-751-09	SCREW +8VTT 3X6 (S)		22	3-703-249-11	SCREW, S TIGHT, +PTWH 3X6	
8	3-311-623-11	SPACER		23	3-703-710-41	STICKER, SONY SYMBOL (12)	
9	*4-908-865-01	PLATE, BOTTOM		24	3-655-653-21	BAND (TAITON), BINDING	
10	4-916-872-11	DAMPER		25	4-916-702-21	DAMPER	
11	7-685-647-79	SCREW +BVTP 3X10 TYPE2 SLIT		26	4-908-885-01	LABEL, TRANSFORMER	
12	7-685-153-29	SCREW +P 3X30 TYPE2 SLIT		27	3-701-690-00	{UK}...LABEL (MADE IN JAPAN)	
13	4-908-859-01 4-916-706-01	{EXCEPT FOR E}...KNOB (NA-29) (E)...KNOB (NA-29)		28	3-703-079-21	{UK}...LABEL, CAUTION (BACK)	
14	4-908-860-01	KNOB (NA-22), R		29	3-703-680-00	{US}...LABEL, CAUTION, SUB, NEW UL	
15	4-908-858-01	KNOB (NA-22), FLAT					

TA-F444ESX/F700ES

(2)

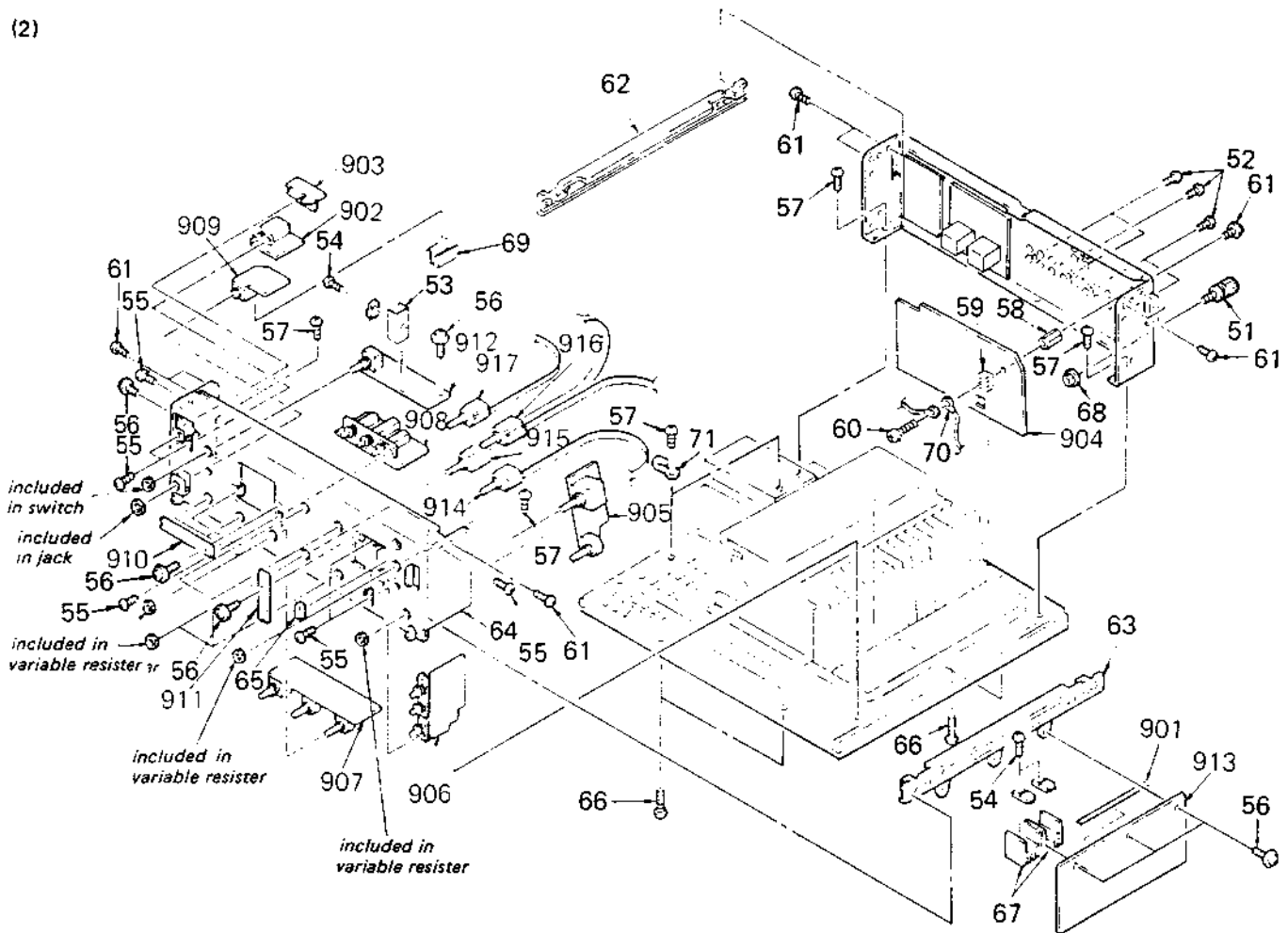

No.	Part No.	Description	Remarks
51	X-4854-207-0	TERMINAL ASSY, GROUND	
52	7-685-646-29	SCREW +BVTP 3X8 TYPE2 SLIT	
53	*4-880-403-11	HEAT SINK	
54	7-682-548-09	SCREW +B 3X8	
55	7-685-751-09	SCREW +BVTT 3X6 (S)	
56	3-703-249-11	SCREW, S TIGHT, +PTWH 3X6	
57	7-685-647-79	SCREW +BVTP 3X10 TYPE2 SLIT	
58	*2-280-622-51	SUPPORT (M3), HEXAGON	
59	*4-835-639-00	PLATE, GROUND	
60	2-259-121-21	SCREW, TR	
61	3-703-108-21	SCREW +BV 3X6, S TIGHT	
62	*4-908-861-11	BRACKET, EQ	
63	*4-908-861-01	BRACKET, EQ	
64	*4-908-867-01	CHASSIS, FRONT	
65	*4-908-854-01	CUSHION	
66	7-685-650-29	SCREW +BVTP 3X16 TYPE2 SLIT	
67	*4-363-147-00	HEAT SINK, H.PIN	
68	4-908-880-01	NUT (M3), FLANGE	
69	*4-904-909-01	PLATE (A), SHIELD	
70	7-623-508-01	LUG, 3	
71	4-908-882-01	CLAMP	

No.	Part No.	Description	Remarks
901	*1-560-242-71	BUS BAR 6P	
902	*1-618-512-11	PC BOARD, AC-SW	
903	*1-618-513-11	PC BOARD, LAMP	
904	*1-618-514-11	PC BOARD, INPUT	
905	*1-618-515-11	PC BOARD, VR	
906	*1-618-516-11	PC BOARD, S.D	
907	*1-618-517-11	PC BOARD, TONE	
908	*1-618-518-11	PC BOARD, TONE-SW	
909	*1-618-519-11	PC BOARD, H.P	
910	*1-618-520-11	PC BOARD, LED-A (TONE)	
911	*1-618-521-11	PC BOARD, LED-B (S.D)	
912	*1-618-511-11	PC BOARD, SP-SW	
913	*A-4358-183-A	(EXCEPT FOR G-AEP)...MOUNTED PCB, EQ	
	*A-4358-184-A	(G-AEP).....MOUNTED PCB, EQ	
914	1-570-588-11	SWITCH, ROTARY SLIDE (REMOTE) (CARTRIDGE LOAD)	
915	1-570-589-11	SWITCH, ROTARY SLIDE (REMOTE) (REC OUT SELECT)	
916	1-570-590-11	SWITCH, ROTARY SLIDE (REMOTE)	
917	1-570-591-11	SWITCH, ROTARY SLIDE (REMOTE) (TAPE SELECT)	

(3)

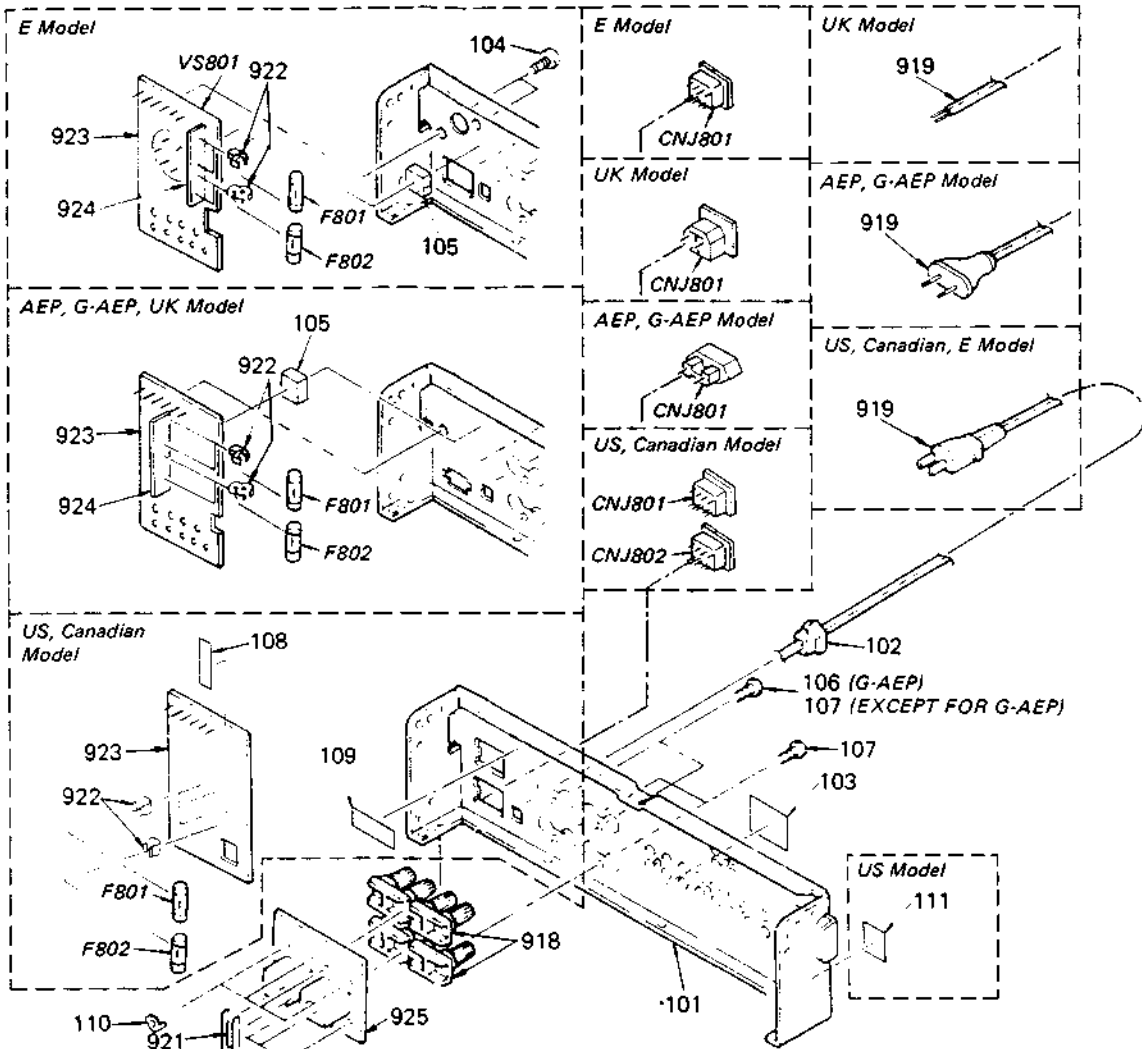

The components identified by shading and mark \triangle are critical for safety. Replace only with part number specified.

Les composants identifiés par une trame et une marque \triangle sont critiques pour la sécurité. Ne les remplacer que par une pièce portant le numéro spécifié.

No.	Part No.	Description	Remarks	No.	Part No.	Description	Remarks
101	*4-908-866-21	{AEP}.....PLATE, JACK		919	\triangle 1-555-386-00	{E}.....CORD, POWER	
	*4-908-866-31	{G-AEP}.....PLATE, JACK			\triangle 1-557-577-11	{US,Canadian}...CORD, POWER	
	*4-908-866-41	{UK}.....PLATE, JACK			\triangle 1-559-271-11	{AEP,G-AEP}...CORD, POWER	
	*4-908-866-51	{E}.....PLATE, JACK			\triangle 1-559-272-11	{UK}.....CORD, POWER	
	*4-916-871-01	{US,Canadian}...PLATE, JACK		920	*1-560-242-11	BUS BAR 3P	
102	2-371-561-00	{US,Canadian}...BUSHING, {P} INSULTING		921	*1-560-242-61	BUS BAR 2P	
	3-703-244-00	{E}.....BUSHING (2104), CORD		922	\triangle 1-533-183-11	{AEP,G-AEP,UK,E}...HOLDER, FUSE	
	4-916-783-01	{AEP,G-AEP,UK}...BUSHING, CORD PA			\triangle 1-553-185-11	{US,Canadian}...HOLDER, FUSE	
103	*4-908-896-01	{US}.....LABEL, MODEL NUMBER		923	*1-618-523-11	{US,Canadian}...PC BOARD, OUTLET	
	*4-908-897-01	{Canadian}...LABEL, MODEL NUMBER			*1-619-928-11	{E}.....PC BOARD, Y.S	
	*4-908-898-01	{AEP}.....LABEL, MODEL NUMBER			*1-619-930-11	{AEP,G-AEP,UK}...PC BOARD, OUTLET	
	*4-908-899-02	{UK}.....LABEL, MODEL NUMBER		924	*1-619-929-11	{E}.....PC BOARD, FUSE (E)	
	*4-916-701-01	{E}.....LABEL, MODEL NUMBER			*1-619-931-11	{AEP,G-AEP,UK}...PC BOARD, FUSE	
	*4-916-702-02	{G-AEP}.....LABEL, MODEL NUMBER		925	*1-618-522-11	PC BOARD, SP-TM	
104	7-685-871-09	{E}...SCREW +BVTT 3X6 Bzn		CNJ801A	\triangle 1-526-576-00	{UK}.....OUTLET AC	
105	4-916-707-01	{AEP,G-AEP,UK,E}...CUSHION		CNJ801A	\triangle 1-526-794-11	{AEP,G-AEP}...OUTLET AC	
106	4-887-711-21	{G-AEP}...SCREW, TERMINAL, CLAW, +BVTP		CNJ801A	\triangle 1-526-883-00	{US,Canadian,E}...OUTLET AC	
107	7-685-646-29	SCREW +BVTP 3x8 TYPE2 SLIT		CNJ802A	\triangle 1-526-883-00	{US,Canadian}...OUTLET AC	
108	3-701-946-28	{US,Canadian}...LABEL, FUSE		F801	\triangle 1-532-237-00	{AEP,G-AEP,UK,E}...FUSE, TIME-LAG 3.15A	
109	3-703-044-26	{US,Canadian}...LABEL, CAUTION		F801	\triangle 1-532-883-00	{US,Canadian}...FUSE, GLASS 6.3A	
110	*4-843-416-11	PLATE, FIXED, CAP		F802	\triangle 1-532-237-00	{E}...FUSE, GLASS 3.15A	
111	3-703-680-00	{US}...LABEL, CAUTION, SUB, NEW UL		F802	\triangle 1-532-286-00	{AEP,G-AEP,UK}...FUSE, TIME-LAG 2.5A	
919	1-536-767-21	TERMINAL BOARD, SPEAKER		F802	\triangle 1-532-883-00	{US,Canadian}...FUSE, GLASS 6.3A	
				VS801	\triangle 1-526-576-31	{E}...SELECTOR, POWER VOLTAGE	

TA-F444ESX/F700ES

(4)

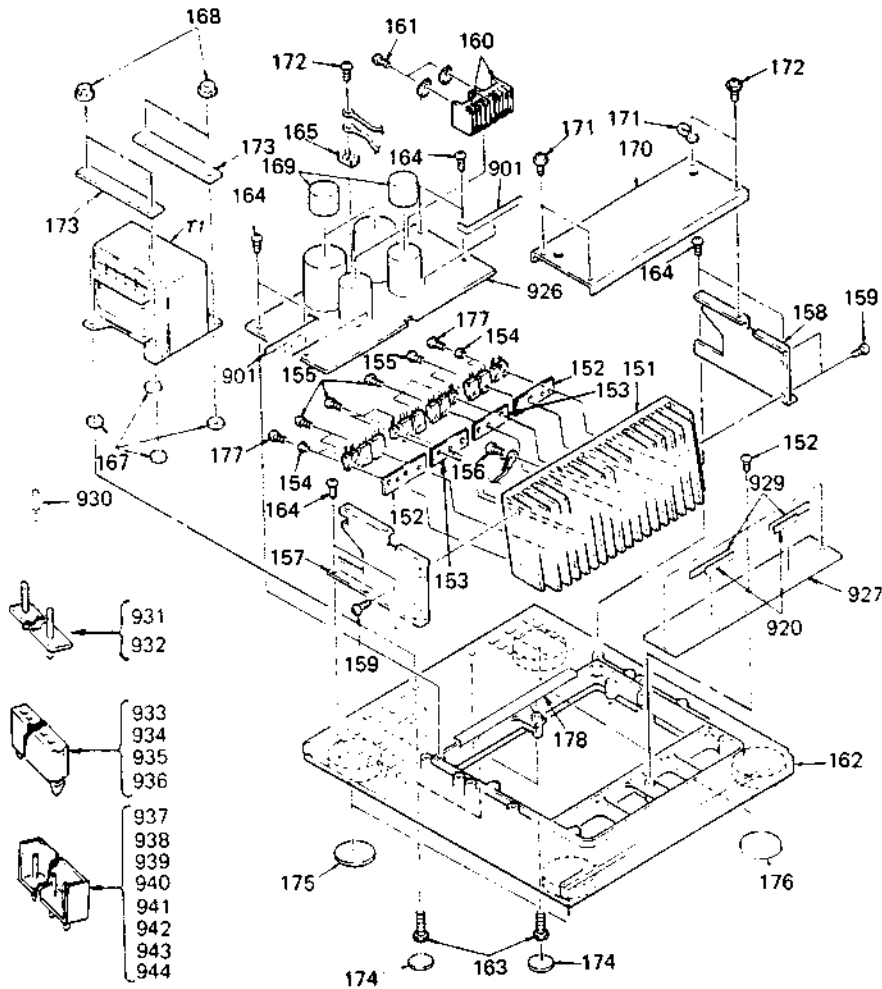

The components identified by shading and mark Δ are critical for safety. Replace only with part number specified.

Les composants identifiés par une trame et une marque Δ sont critiques pour la sécurité. Ne les remplacer que par une pièce portant le numéro spécifié.

No.	Part No.	Description	Remarks
151	*4-908-874-11	HEAT SINK	
152	4-916-709-01	SHEET (B), INSULATING	
153	4-916-708-01	SHEET (A), INSULATING	
154	2-371-561-00	BUSHING (P), INSULATING	
155	7-682-549-09	SCREW +B 3X10	
156	7-682-561-10	SCREW +B 4X8	
157	*4-908-863-01	BRACKET (FRONT), HEAT SINK	
158	*4-908-864-01	BRACKET (REAR), HEAT SINK	
159	7-685-646-29	SCREW +BVTP 3X8 TYPE2 SLIT	
160	*4-363-147-00	HEAT SINK, H.PIN	
161	7-682-548-09	SCREW +B 3X8	
162	X-4885-922-1	CHASSIS, MAIN ASSY	
163	7-683-333-07	BOLT, HEXAGON 4X40	
164	7-685-647-79	SCREW +BVTP 3X10 TYPE2 SLIT	
165	*4-880-404-01	PLATE, GROUND	
166	7-685-648-29	SCREW +BVTP 3X12 TYPE2 SLIT	
167	*4-885-984-01	WASHER	
168	4-908-881-01	NUT (M4), FLANGE	
169	*4-908-853-01	CUSHION	
170	*4-908-862-01	RETAINER, CHEMICAL CAPACITOR	
171	*4-908-882-01	CLAMP	
172	3-703-249-11	SCREW, S TIGHT, +PTTWH 3X6	
173	*4-908-886-01	REINFORCEMENT, TRANSFORMER	
174	*4-908-892-01	SPACER	
175	*4-908-888-01	(US,Canadian,AEP,UK)...FOOT, TUNING	
	*4-916-704-01	(G-AEP,E).....FOOT	
176	*4-908-887-01	(US,Canadian,AEP,UK)...FOOT, TUNING	
	*4-916-704-11	(G-AEP,E).....FOOT	
177	7-682-649-09	SCREW +PS 3X10	
178	4-916-763-01	(US)...SHEET, INSULATING	

No.	Part No.	Description	Remarks
901	*1-560-242-71	BUS BAR 6P	
920	*1-560-242-11	BUS BAR 3P	
926	*A-4388-584-A	(EXCEPT FOR G-AEP) ...MOUNTED PCB, MAIN (B)	
	*A-4388-585-A	(G-AEP)....MOUNTED PCB, MAIN (B)	
927	*A-4388-582-A	(EXCEPT FOR G-AEP)MOUNTED PCB, MAIN (A)	
	*A-4388-583-A	(G-AEP)....MOUNTED PCB, MAIN (A)	
929	*1-560-242-21	BUS BAR 4P	
930	*1-535-492-00	PIN, GT	
931	*1-508-809-00	BASE POST (14MM) 2P	
932	*1-535-136-00	(AEP,G-AEP,UK,E)BASE POST 14MM (10MM PITCH) 3P	
933	*1-562-249-00	SOCKET, CONNECTOR 4P	
934	*1-562-250-00	SOCKET, CONNECTOR 5P	
935	*1-562-251-00	SOCKET, CONNECTOR 6P	
936	*1-562-327-00	SOCKET, CONNECTOR 3P	
937	*1-564-505-11	PLUG, CONNECTOR 2P, WHITE	
938	*1-564-505-31	PLUG, CONNECTOR 2P, RED	
939	*1-564-506-11	PLUG, CONNECTOR 3P, WHITE	
940	*1-564-507-11	PLUG, CONNECTOR 4P, WHITE	
941	*1-564-507-21	PLUG, CONNECTOR 4P, BLACK	
942	*1-564-507-31	PLUG, CONNECTOR 4P, RED	
943	*1-564-508-11	PLUG, CONNECTOR 5P, WHITE	
944	*1-564-509-11	PLUG, CONNECTOR 6P, WHITE	
T1	Δ 1-448-631-11	(UK,G-AEP).....TRANSFORMER, POWER	
	Δ 1-448-632-11	(E).....TRANSFORMER, POWER	
	Δ 1-448-633-11	(US,Canadian).....TRANSFORMER, POWER	
	Δ 1-448-634-11	(AEP).....TRANSFORMER, POWER	

**SECTION 6
ELECTRICAL PARTS LIST**

NOTE:

- Items marked * are not stocked since they are seldom required for routine service. Some delay should be anticipated when ordering these items.
- If there are two or more same circuits in a set such as a stereophonic machine, only typical circuit parts may be indicated and capacitors and resistors in other same circuits may be omitted.

CAPACITORS:

MF:µF, PF:µPF.

RESISTORS

• All resistors are in ohms.

• F : nonflammable

COILS

• MMH : mH, UH : µH

SEMICONDUCTORS

In each case, U : .. for example:







UA....: UA...., UPA....: UPA...., UPC....: UPC....

UPD....: UPD....

The components identified by shading and mark  are critical for safety. Replace only with part number specified.

Les composants identifiés par une trame et une marque  sont critiques pour la sécurité. Ne les remplacer que par une pièce portant le numéro spécifié.

ELECTRICAL PARTS

Ref.No.	Part No.	Description
901	*1-560-242-71	BUS BAR 6P
902	*1-618-512-11	PC BOARD, AC-SW
903	*1-618-513-11	PC BOARD, LAMP
904	*1-618-514-11	PC BOARD, INPUT
905	*1-618-515-11	PC BOARD, VR
906	*1-618-516-11	PC BOARD, S.D
907	*1-618-517-11	PC BOARD, TONE
908	*1-618-518-11	PC BOARD, TONE-SW
909	*1-618-519-11	PC BOARD, H.P
910	*1-618-520-11	PC BOARD, LED-A (TONE)
911	*1-618-521-11	PC BOARD, LED-B (S.D)
912	*1-618-511-11	PC BOARD, SP-SW
913	*A-4358-183-A	(US,Canadian,AEP,UK,E)...MOUNTED PCB, EQ
	*A-4358-184-A	(G-AEP).....MOUNTED PCB, EQ
914	1-570-588-11	SWITCH, ROTARY SLIDE (REMOTE)
915	1-570-589-11	SWITCH, ROTARY SLIDE (REMOTE)
916	1-570-590-11	SWITCH, ROTARY SLIDE (REMOTE)
917	1-570-591-11	SWITCH, ROTARY SLIDE (REMOTE)
918	1-536-767-21	TERMINAL BOARD, SPEAKER
919	 1-555-386-00	(E).....CORD, POWER
	 1-557-577-11	(US,Canadian)...CORD, POWER
	 1-559-271-11	(AEP,G-AEP).....CORD, POWER
	 1-559-272-00	(UK).....CORD, POWER
920	*1-560-242-11	BUS BAR 3P
921	*1-560-242-61	BUS BAR 2P
922	 1-533-183-11	(AEP,G-AEP,UK,E)...HOLDER, FUSE
	 1-533-185-11	(US,Canadian).....HOLDER, FUSE
923	*1-618-523-11	(US,Canadian)....PC BOARD, OUTLET
	*1-619-928-11	(E).....PC BOARD, V.S
	*1-619-930-11	(AEP,G-AEP,UK)...PC BOARD, OUTLET
924	*1-619-929-11	(E).....PC BOARD, FUSE (E)
	*1-619-931-11	(AEP,G-AEP,UK)...PC BOARD, FUSE (E)
925	*1-618-522-11	PC BOARD, SP-TM
926	*A-4388-584-A	(EXCEPT FOR G-AEP)..MOUNTED PCB, MAIN(B)
	*A-4388-585-A	(G-AEP).....MOUNTED PCB, MAIN(B)
927	*A-4388-582-A	(EXCEPT FOR G-AEP)..MOUNTED PCB, MAIN(A)
	*A-4388-583-A	(G-AEP).....MOUNTED PCB, MAIN(A)
929	*1-560-242-21	BUS BAR 4P
930	*1-535-492-00	PIN, GT
931	*1-508-809-00	BASE POST (14MM) 2P
932	*1-535-136-00	BASE POST 14MM (10MM PITCH) 3P
933	*1-562-249-00	SOCKET, CONNECTOR 4P
934	*1-562-250-00	SOCKET, CONNECTOR 5P
935	*1-562-251-00	SOCKET, CONNECTOR 6P

ELECTRICAL PARTS

Ref.No.	Part No.	Description
936	*1-562-327-00	SOCKET, CONNECTOR 3P
937	*1-564-505-11	PLUG, CONNECTOR 2P, WHITE
938	*1-564-505-31	PLUG, CONNECTOR 2P, RED
939	*1-564-506-11	PLUG, CONNECTOR 3P, WHITE
940	*1-564-507-11	PLUG, CONNECTOR 4P, WHITE
941	*1-564-507-21	PLUG, CONNECTOR 4P, BLACK
942	*1-564-507-31	PLUG, CONNECTOR 4P, RED
943	*1-564-508-11	PLUG, CONNECTOR 5P, WHITE
944	*1-564-509-11	PLUG, CONNECTOR 6P, WHITE
C101	1-161-315-00	(G-AEP)...CERAMIC 220PF 10% 50V
C102	1-161-272-00	(G-AEP)...CERAMIC 120PF 5% 50V
C103	1-107-309-00	(G-AEP)...MICA 100PF 5% 500V
C151	1-161-315-00	(G-AEP)...CERAMIC 220PF 10% 50V
C152	1-161-272-00	(G-AEP)...CERAMIC 120PF 5% 50V
C153	1-107-309-00	(G-AEP)...MICA 100PF 5% 500V
C201	1-104-249-11	(EXCEPT FOR G-AEP) ...POLYSTYRENE 330PF 5% 125V
C201	1-107-294-00	(G-AEP)...MICA 56PF 5% 100V
C202	1-104-150-00	(EXCEPT FOR G-AEP) ...POLYSTYRENE 680PF 5% 125V
C202	1-104-151-00	(G-AEP)...POLYSTYRENE 0.0022MF 5% 125V
C203	1-123-373-00	ELECT 47MF 20% 63V
C204	1-123-373-00	ELECT 47MF 20% 63V
C205	1-136-267-11	FILM 0.0036MF 3% 100V
C206	1-130-206-00	FILM 0.016MF 2% 630V
C207	1-130-205-00	FILM 0.056MF 2% 630V
C208	1-130-281-00	FILM 0.0022MF 5% 100V
C209	1-123-337-00	ELECT 1000MF 20% 25V
C211	1-123-332-00	ELECT 47MF 20% 25V
C212	1-123-356-00	ELECT 10MF 20% 50V
C214	1-123-369-00	ELECT 4.7MF 20% 50V
C251	1-104-249-11	(EXCEPT FOR G-AEP) ...POLYSTYRENE 330PF 5% 125V
C251	1-107-294-00	(G-AEP)...MICA 56PF 5% 100V
C252	1-104-150-00	(EXCEPT FOR G-AEP) ...POLYSTYRENE 680PF 5% 25V
C252	1-104-151-00	(G-AEP)...POLYSTYRENE 0.0022MF 5% 125V
C253	1-123-373-00	ELECT 47MF 20% 63V
C254	1-123-373-00	ELECT 47MF 20% 63V
C255	1-136-267-11	FILM 0.0036MF 3% 100V
C256	1-130-206-00	FILM 0.016MF 2% 630V
C257	1-130-205-00	FILM 0.056MF 2% 630V
C258	1-130-281-00	FILM 0.0022MF 5% 100V
C259	1-123-337-00	ELECT 1000MF 20% 25V
C261	1-123-332-00	ELECT 47MF 20% 25V
C262	1-123-356-00	ELECT 10MF 20% 50V

TA-F44ESX/F700ES

ELECTRICAL PARTS

Ref.No.	Part No.	Description				
C264	1-123-369-00	ELECT	4.7MF	20%	50V	
C301	1-136-171-00	FILM	0.33MF	5%	50V	
C302	1-110-219-11	MYLAR	680PF	5%	50V	
C303	1-110-219-11	MYLAR	680PF	5%	50V	
C304	1-110-200-00	MYLAR	0.0027MF	5%	50V	
C305	1-110-200-00	MYLAR	0.0027MF	5%	50V	
C306	1-110-206-00	MYLAR	0.0082MF	5%	50V	
C307	1-110-206-00	MYLAR	0.0082MF	5%	50V	
C308	1-136-161-00	FILM	0.047MF	5%	50V	
C309	1-136-161-00	FILM	0.047MF	5%	50V	
C351	1-136-171-00	FILM	0.33MF	5%	50V	
C352	1-110-219-11	MYLAR	680PF	5%	50V	
C353	1-110-219-11	MYLAR	680PF	5%	50V	
C354	1-110-200-00	MYLAR	0.0027MF	5%	50V	
C355	1-110-200-00	MYLAR	0.0027MF	5%	50V	
C356	1-110-206-00	MYLAR	0.0082MF	5%	50V	
C357	1-110-206-00	MYLAR	0.0082MF	5%	50V	
C358	1-136-161-00	FILM	0.047MF	5%	50V	
C359	1-136-161-00	FILM	0.047MF	5%	50V	
C401	1-107-279-00	MICA	10PF	0.5PF	100V	
C402	1-104-233-00	POLYSTYRENE	220PF	5%	125V	
C403	1-123-380-00	ELECT	1MF	20%	100V	
C404	1-107-276-11	(EXCEPT FOR G-AEP)...MICA	3PF	0.5PF	100V	
C404	1-107-279-00	(G-AEP)...MICA	10PF	0.5PF	100V	
C405	1-123-373-00	ELECT	47MF	20%	63V	
C406	1-123-373-00	ELECT	47MF	20%	63V	
C407	1-123-373-00	ELECT	47MF	20%	63V	
C408	1-123-373-00	ELECT	47MF	20%	63V	
C409	1-130-317-00	FILM	0.068MF	5%	100V	
C410	1-107-279-00	MICA	10PF	0.5PF	100V	
C411	1-123-374-00	ELECT	100MF	20%	63V	
C412	1-123-374-00	ELECT	100MF	20%	63V	
C414	1-107-169-00	(G-AEP)...MICA	27PF	5%	100V	
C414	1-107-286-00	(EXCEPT FOR G-AEP)...MICA	100PF	5%	100V	
C414	1-107-169-00	(G-AEP)...MICA	27PF	5%	100V	
C415	1-107-286-00	(EXCEPT FOR G-AEP)...MICA	27PF	5%	100V	
C416	1-136-161-00	FILM	0.047MF	5%	50V	
C417	1-136-161-00	FILM	0.047MF	5%	50V	
C418	1-123-378-00	ELECT	1000MF	20%	63V	
C419	1-123-378-00	ELECT	1000MF	20%	63V	
C420	1-107-282-91	(G-AEP)...MICA	18PF	5%	100V	
C421	1-107-169-00	(G-AEP)...MICA	100PF	5%	100V	
C422	1-136-162-00	(G-AEP)...FILM	0.056MF	5%	50V	
C423	1-136-230-00	(G-AEP)...FILM	0.0022MF	5%	100V	
C451	1-107-279-00	MICA	10PF	0.5PF	100V	
C452	1-104-233-00	POLYSTYRENE	220PF	5%	125V	
C453	1-123-380-00	ELECT	1MF	20%	100V	
C454	1-107-202-00	(G-AEP)...MICA	10PF	0.5PF	100V	
C454	1-107-276-11	(EXCEPT FOR G-AEP)...MICA	3PF	0.5PF	100V	
C455	1-123-373-00	ELECT	47MF	20%	63V	
C456	1-123-373-00	ELECT	47MF	20%	63V	
C457	1-123-373-00	ELECT	47MF	20%	63V	
C458	1-123-373-00	ELECT	47MF	20%	63V	
C459	1-130-317-00	FILM	0.068MF	5%	100V	
C460	1-107-279-00	MICA	10PF	0.5PF	100V	

ELECTRICAL PARTS

Ref.No.	Part No.	Description				
C461	1-123-374-00	ELECT	100MF	20%	63V	
C462	1-123-374-00	ELECT	100MF	20%	63V	
C464	1-107-169-00	(G-AEP)...MICA	100PF	5%	100V	
C464	1-107-286-00	(EXCEPT FOR G-AEP)...MICA	27PF	5%	100V	
C465	1-107-169-00	(G-AEP)...MICA	100PF	5%	100V	
C465	1-107-286-00	(EXCEPT FOR G-AEP)...MICA	27PF	5%	100V	
C466	1-136-161-00	FILM	0.047MF	5%	50V	
C467	1-136-161-00	FILM	0.047MF	5%	50V	
C468	1-123-378-00	ELECT	1000MF	20%	63V	
C469	1-123-378-00	ELECT	1000MF	20%	63V	
C470	1-107-282-91	(G-AEP)...MICA	18PF	5%	100V	
C471	1-107-169-00	(G-AEP)...MICA	100PF	5%	100V	
C472	1-163-162-00	(G-AEP)...FILM	0.056MF	5%	50V	
C473	1-163-230-00	(G-AEP)...FILM	0.0022MF	5%	100V	
C502	1-123-333-00	ELECT	100MF	20%	25V	
C601	1-123-334-00	ELECT	220MF	20%	25V	
C602	1-110-195-00	MYLAR	0.001MF	5%	50V	
C603	1-136-157-00	FILM	0.022MF	5%	50V	
C604	1-123-343-00	ELECT	33MF	20%	25V	
C605	1-123-369-00	ELECT	4.7MF	20%	50V	
C606	1-123-380-00	ELECT	1MF	20%	50V	
C607	1-123-382-00	ELECT	33MF	20%	50V	
C608	1-123-382-00	ELECT	33MF	20%	50V	
C609	1-130-273-00	FILM	0.001MF	5%	100V	
C610	1-130-291-00	(G-AEP)...FILM	0.0056MF	5%	100V	
C611	1-136-230-00	(G-AEP)...FILM	0.0022MF	5%	100V	
C660	1-130-291-00	(G-AEP)...FILM	0.0056MF	5%	100V	
C661	1-136-230-00	(G-AEP)...FILM	0.0022MF	5%	100V	
C701	1-125-431-11	ELECT	4700MF	20%	63V	
C702	1-125-381-00	ELECT	12000MF	20%	63V	
C703	1-123-378-00	ELECT	1000MF	20%	63V	
C705	1-130-801-11	FILM	3.3MF	10%	250V	
C707	1-123-377-00	(G-AEP)...ELECT	470MF	20%	63V	
C751	1-125-431-11	ELECT	4700MF	20%	63V	
C752	1-125-381-00	ELECT	12000MF	20%	63V	
C753	1-123-378-00	ELECT	1000MF	20%	63V	
C757	1-123-377-00	(G-AEP)...ELECT	470MF	20%	63V	
C801	1-161-741-00	CERAMIC	0.001MF	10%	400V	
C802	1-161-741-00	(UK,AEP,G-AEP,E)...CERAMIC	0.001MF	10%	400V	
C999	1-136-167-00	FILM	0.15MF	5%	50V	
CNJ801A	1-526-751-00	(UK)...OUTLET, AC				
CNJ801A	1-526-794-11	(AEP,G-AEP)...OUTLET, AC				
CNJ801A	1-526-883-00	(US,Canadian,E)...OUTLET, AC				
CNJ802A	1-526-883-00	(US,Canadian,E)...OUTLET, AC				
D201	8-719-910-53	DIODE HZ15-3L				
D202	8-719-910-53	DIODE HZ15-3L				
D204	8-719-940-76	DIODE 1S5132				
D251	8-719-910-53	DIODE HZ15-3L				
D252	8-719-910-53	DIODE HZ15-3L				
D401	8-719-910-69	DIODE HZ6C3L				
D402	8-719-940-76	DIODE 1S5132				
D403	8-719-940-76	DIODE 1S5132				
D404	8-719-300-03	DIODE 5V-03				
D407	8-719-940-76	DIODE 1S5132				

The components identified by shading and mark Δ are critical for safety. Replace only with part number specified.

Les composants identifiés par une trame et une marque Δ sont critiques pour la sécurité. Ne les remplacer que par une pièce portant le numéro spécifié.

ELECTRICAL PARTS

Ref.No.	Part No.	Description
D408	8-719-940-76	DIODE 1SS132
D409	8-719-940-76	DIODE 1SS132
D410	8-719-940-76	DIODE 1SS132
D411	8-719-940-76	DIODE 1SS132
D412	Δ 8-719-300-02	DIODE SV-02
D413	8-719-940-76	DIODE 1SS132
D414	8-719-940-76	DIODE 1SS132
D415	8-719-940-76	DIODE 1SS132
D416	8-719-940-76	DIODE 1SS132
D417	8-719-910-65	DIODE HZ782L
D451	8-719-910-69	DIODE HZ6C3L
D452	8-719-940-76	DIODE 1SS132
D453	8-719-940-76	DIODE 1SS132
D454	8-719-300-03	DIODE SV-03
D457	8-719-940-76	DIODE 1SS132
D458	8-719-940-76	DIODE 1SS132
D459	8-719-940-76	DIODE 1SS132
D460	8-719-940-76	DIODE 1SS132
D461	8-719-940-76	DIODE 1SS132
D462	Δ 8-719-300-02	DIODE SV-02
D463	8-719-940-76	DIODE 1SS132
D464	8-719-940-76	DIODE 1SS132
D465	8-719-940-76	DIODE 1SS132
D466	8-719-940-76	DIODE 1SS132
D467	8-719-910-65	DIODE HZ782L
D501	8-719-930-12	DIODE EQ801-12Z
D502	8-719-910-69	DIODE HZ6C3L
D503	8-719-940-76	DIODE 1SS132
D505	8-719-301-49	DIODE SEL2810A
D506	8-719-301-49	DIODE SEL2810A
D507	8-719-301-49	DIODE SEL2810A
D601	Δ 8-719-910-75	DIODE HZ982L
D602	8-719-910-11	DIODE HZ11A1L
D603	8-719-200-77	DIODE 10E2N
D604	8-719-940-76	DIODE 1SS132
D605	8-719-940-76	DIODE 1SS132
D701	Δ 8-719-230-02	DIODE 300F2
D702	Δ 8-719-230-02	DIODE 300F2
D703	Δ 8-719-230-02	DIODE 300F2
D704	Δ 8-719-230-02	DIODE 300F2
D705	Δ 8-719-300-27	DIODE CTU-22S
D755	Δ 8-719-300-25	DIODE CTU-22R
F801	Δ 1-532-237-00	(AEP,G-AEP,UK,E)...FUSE, TIME-LAG, 3.15A
F801	Δ 1-532-883-00	(US,Canadian)...FUSE, GLASS 6.3A
F802	Δ 1-532-237-00	(E).....FUSE, TIME-LAG, 3.15A
F802	Δ 1-532-286-00	(AEP,G-AEP,UK)...FUSE, TIME-LAG, 2.5A
F802	Δ 1-532-883-00	(US,Canadian)...FUSE, GLASS 6.3A
J101	1-507-830-21	JACK, PIN 4P (ADAPTOR)
J102	1-507-830-00	JACK, PIN 4P (INPUT PHONO/TUNER)
J103	1-507-830-00	JACK, PIN 4P (INPUT/CD/AUX)
J104	1-507-831-00	JACK, PIN 6P (TAPE RECORDER 1/2)
J105	1-507-831-00	JACK, PIN 6P (TAPE RECORDER 2/3)
J601	1-507-707-00	JACK, LARGE TYPE (HEADPHONES)
IC201	8-759-602-01	(G-AEP).....IC M5220P
IC201	8-759-701-21	(EXCEPT FOR G-AEP)...IC NJM55320-D
IC202	8-759-601-02	IC M5218P
IC601	8-759-101-23	IC UPC1237H

ELECTRICAL PARTS

Ref.No.	Part No.	Description
L101	1-413-101-00	(G-AEP)...COIL, INPUT
L102	1-413-101-00	(G-AEP)...COIL, INPUT
L151	1-413-101-00	(G-AEP)...COIL, INPUT
L152	1-413-101-00	(G-AEP)...COIL, INPUT
L401	*1-422-009-13	COIL, AIR-CORE
L402	1-422-261-11	COIL, AIR-CORE
L403	1-422-261-11	COIL, AIR-CORE
L451	*1-422-009-13	COIL, AIR-CORE
L452	1-422-261-11	COIL, AIR-CORE
L453	1-422-261-11	COIL, AIR-CORE
PTH701	Δ 1-806-882-11	(EXCEPT FOR G-AEP) ...THERMISTOR (POSITIVE)
PTH751	Δ 1-806-882-11	(EXCEPT FOR G-AEP) ...THERMISTOR (POSITIVE)
PL601	1-518-518-41	LAMP, PILOT
PL602	1-518-518-41	LAMP, PILOT
Q201	8-729-217-03	TRANSISTOR 2SK170
Q202	8-729-366-81	TRANSISTOR 2SD668
Q203	8-729-600-27	TRANSISTOR 2SC634SP
Q204	8-729-201-56	TRANSISTOR 2SK246-GR2
Q205	8-729-127-53	TRANSISTOR 2SC2275-P
Q206	8-729-201-56	TRANSISTOR 2SK246-GR2
Q207	8-729-217-03	TRANSISTOR 2SK170
Q251	8-729-217-03	TRANSISTOR 2SK170
Q252	8-729-366-81	TRANSISTOR 2SD668
Q253	8-729-600-27	TRANSISTOR 2SC634SP
Q254	8-729-201-56	TRANSISTOR 2SK246-GR2
Q255	8-729-190-53	TRANSISTOR 2SA985A
Q256	8-729-201-56	TRANSISTOR 2SK246-GR2
Q257	8-729-217-03	TRANSISTOR 2SK170
Q401	8-729-203-21	TRANSISTOR 2SK389-GR
Q402	8-729-600-27	TRANSISTOR 2SC634SP
Q403	8-729-600-27	TRANSISTOR 2SC634SP
Q404	8-729-699-51	TRANSISTOR 2SA995
Q405	Δ 8-729-114-22	TRANSISTOR 2SA1142
Q406	Δ 8-729-104-91	TRANSISTOR 2SA1383
Q407	8-729-201-56	TRANSISTOR 2SK246-GR2
Q408	8-729-104-18	TRANSISTOR 2SC3514
Q409	8-729-104-18	TRANSISTOR 2SC3514
Q410	Δ 8-729-173-13	TRANSISTOR 2SB731
Q411	Δ 8-729-180-93	TRANSISTOR 2SD809
Q412	Δ 8-729-104-18	TRANSISTOR 2SC3514
Q413	Δ 8-729-104-91	TRANSISTOR 2SA1383
Q414	Δ 8-729-127-53	TRANSISTOR 2SC2275-P
Q415	Δ 8-729-190-53	TRANSISTOR 2SA985A
Q416	Δ 8-729-383-73	TRANSISTOR 2SC2837
Q417	Δ 8-729-383-73	TRANSISTOR 2SC2837
Q418	Δ 8-729-318-63	TRANSISTOR 2SA1186
Q419	Δ 8-729-318-63	TRANSISTOR 2SA1186
Q420	8-729-108-14	TRANSISTOR 2SA988-F
Q451	8-729-203-21	TRANSISTOR 2SK389-GR
Q452	8-729-600-27	TRANSISTOR 2SC634SP
Q453	8-729-600-27	TRANSISTOR 2SC634SP
Q454	8-729-699-51	TRANSISTOR 2SA995
Q455	Δ 8-729-114-22	TRANSISTOR 2SA1142
Q456	Δ 8-729-104-91	TRANSISTOR 2SA1383
Q457	8-729-201-56	TRANSISTOR 2SK246-GR2
Q458	8-729-104-18	TRANSISTOR 2SC3514

The components identified by shading and mark Δ are critical for safety. Replace only with part number specified.	Les composants identifiés par une trame et une marque Δ sont critiques pour la sécurité. Ne les remplacer que par une pièce portant le numéro spécifié.
---	---

TA-F444ESX/F700ES

ELECTRICAL PARTS

Ref.No.	Part No.	Description			
Q459	8-729-104-18	TRANSISTOR 2SC3514			
Q460	▲ 8-729-173-13	TRANSISTOR 2SB731			
Q461	▲ 8-729-180-93	TRANSISTOR 2SB809			
Q462	▲ 8-729-104-18	TRANSISTOR 2SC3514			
Q463	▲ 8-729-104-91	TRANSISTOR 2SA1383			
Q464	▲ 8-729-127-53	TRANSISTOR 2SC2275-P			
Q465	▲ 8-729-190-53	TRANSISTOR 2SA985A			
Q466	▲ 8-729-383-73	TRANSISTOR 2SC2837			
Q467	▲ 8-729-383-73	TRANSISTOR 2SC2837			
Q468	▲ 8-729-318-63	TRANSISTOR 2SA1186			
Q469	▲ 8-729-318-63	TRANSISTOR 2SA1186			
Q470	8-729-108-14	TRANSISTOR 2SA988-F			
Q501	8-729-612-77	TRANSISTOR 2SA1027R			
Q601	▲ 8-729-111-67	TRANSISTOR 2SB1094-L			
Q602	▲ 8-729-364-72	TRANSISTOR 2SB647			
Q603	8-729-103-43	TRANSISTOR 2SB734			
Q604	8-729-103-43	TRANSISTOR 2SB734			
Q605	8-729-108-05	TRANSISTOR 2SC1841-PA			
R101	1-246-545-00	CARBON	1M		1/4W
R102	1-246-545-00	CARBON	1M		1/4W
R103	1-246-545-00	CARBON	1M		1/4W
R104	1-246-545-00	CARBON	1M		1/4W
R105	1-246-545-00	CARBON	1M		1/4W
R106	1-246-545-00	CARBON	1M		1/4W
R107	1-247-713-11	CARBON	1K		1/4W
R108	1-247-713-11	CARBON	1K		1/4W
R109	1-247-713-11	CARBON	1K		1/4W
R110	1-247-713-11	(G-AEP).....CARBON	1K		1/2W
R110	1-247-739-11	(EXCEPT FOR G-AEP)...	CARBON 100		1/2W
R111	1-247-706-11	(G-AEP).....CARBON	330		1/4W
R112	1-247-706-11	(G-AEP).....CARBON	330		1/4W
R151	1-246-545-00	CARBON	1M		1/4W
R152	1-246-545-00	CARBON	1M		1/4W
R153	1-246-545-00	CARBON	1M		1/4W
R154	1-246-545-00	CARBON	1M		1/4W
R155	1-246-545-00	CARBON	1M		1/4W
R156	1-246-545-00	CARBON	1M		1/4W
R157	1-247-713-11	CARBON	1K		1/4W
R158	1-247-713-11	CARBON	1K		1/4W
R159	1-247-713-11	CARBON	1K		1/4W
R160	1-247-713-11	(G-AEP).....CARBON	1K		1/2W
R160	1-247-739-11	(EXCEPT FOR G-AEP)...	CARBON 100		1/2W
R161	1-247-706-11	(G-AEP).....CARBON	330		1/4W
R162	1-247-706-11	(G-AEP).....CARBON	330		1/4W
R201	1-249-465-11	CARBON	47K		1/4W
R202	1-247-706-11	CARBON	330		1/4W
R203	1-247-700-11	(G-AEP).....CARBON	100		1/4W
R203	1-247-713-11	(EXCEPT FOR G-AEP)...	CARBON 1K		1/4W
R204	1-247-700-11	(EXCEPT FOR G-AEP)...	CARBON 100		1/4W
R204	1-249-516-91	(G-AEP).....CARBON	33		1/4W
R205	1-247-128-00	CARBON	750		1/4W
R206	1-247-128-00	CARBON	750		1/4W
R207	1-247-700-11	CARBON	100		1/4W
R208	1-247-708-11	CARBON	470	5%	1/4W
R209	1-247-695-11	CARBON	39	5%	1/4W
R210	1-247-704-11	CARBON	220	5%	1/4W
R211	1-247-721-11	CARBON	4.7K	5%	1/4W
R212	1-214-937-00	CARBON	1M		1/2W
R213	1-249-565-11	CARBON	3.6K		1/4W

ELECTRICAL PARTS

Ref.No.	Part No.	Description			
R214	1-214-906-00	METAL	51K	1%	1/2W
R215	1-214-878-00	METAL	3.9K	1%	1/2W
R216	1-247-744-11	CARBON	270		1/2W
R217	1-206-458-00	CARBON	6.2	5%	1/3W
R218	1-247-215-00	CARBON	91		1/2W
R219	1-247-704-11	CARBON	220		1/4W
R220	1-247-725-11	CARBON	10K	5%	1/4W
R221	1-247-704-11	CARBON	220	5%	1/4W
R222	1-247-719-11	CARBON	3.3K	5%	1/4W
R251	1-249-465-11	CARBON	47K		1/4W
R252	1-247-706-11	CARBON	330		1/4W
R253	1-247-700-11	(G-AEP).....CARBON	100		1/4W
R253	1-247-713-11	(EXCEPT FOR G-AEP) ...CARBON	1K		1/4W
R254	1-247-700-11	(EXCEPT FOR G-AEP) ...CARBON	100		1/4W
R254	1-249-516-91	(G-AEP).....CARBON	33		1/4W
R255	1-247-128-00	CARBON	750		1/4W
R256	1-247-128-00	CARBON	750		1/4W
R257	1-247-700-11	CARBON	100		1/4W
R258	1-247-708-11	CARBON	470	5%	1/4W
R259	1-247-695-11	CARBON	39	5%	1/4W
R260	1-247-704-11	CARBON	220	5%	1/4W
R261	1-247-721-11	CARBON	4.7K	5%	1/4W
R262	1-214-937-00	CARBON	1M		1/2W
R263	1-249-565-11	CARBON	3.6K		1/4W
R264	1-214-906-00	METAL	51K	1%	1/2W
R265	1-214-878-00	METAL	3.9K	1%	1/2W
R266	1-247-744-11	CARBON	270		1/2W
R267	1-206-458-00	CARBON	6.2	5%	1/3W
R268	1-247-215-00	CARBON	91		1/2W
R269	1-247-704-11	CARBON	220		1/4W
R270	1-247-725-11	CARBON	10K	5%	1/4W
R271	1-247-704-11	CARBON	220	5%	1/4W
R272	1-247-719-11	CARBON	3.3K	5%	1/4W
R302	1-249-465-11	CARBON	47K		1/4W
R303	1-247-721-11	CARBON	4.7K		1/4W
R304	1-247-722-11	CARBON	5.6K		1/4W
R305	1-247-717-11	CARBON	2.2K		1/4W
R306	1-249-466-11	CARBON	56K		1/4W
R307	1-247-725-11	CARBON	10K		1/4W
R308	1-249-465-11	CARBON	47K		1/4W
R309	1-249-465-11	CARBON	47K		1/4W
R310	1-202-727-00	CARBON	4.7M	5%	1/3W
R311	1-202-727-00	CARBON	4.7M	5%	1/3W
R312	1-202-727-00	CARBON	4.7M	5%	1/3W
R313	1-202-727-00	CARBON	4.7M	5%	1/3W
R314	1-202-727-00	CARBON	4.7M	5%	1/3W
R315	1-202-727-00	CARBON	4.7M	5%	1/3W
R352	1-249-465-11	CARBON	47K		1/4W
R353	1-247-721-11	CARBON	4.7K		1/4W
R354	1-247-722-11	CARBON	5.6K		1/4W
R355	1-247-717-11	CARBON	2.2K		1/4W
R356	1-249-466-11	CARBON	56K		1/4W
R357	1-247-725-11	CARBON	10K		1/4W
R358	1-249-465-11	CARBON	47K		1/4W

The components identified by shading and mark ▲ are critical for safety. Replace only with part number specified.

Les composants identifiés par une trame et une marque ▲ sont critiques pour la sécurité. Ne les remplacer que par une pièce portant le numéro spécifié.

ELECTRICAL PARTS

Ref.No.	Part No.	Description			
R359	1-249-465-11	CARBON	47K		1/4W
R360	1-202-727-00	CARBON	4.7M	5%	1/3W
R361	1-202-727-00	CARBON	4.7M	5%	1/3W
R362	1-202-727-00	CARBON	4.7M	5%	1/3W
R363	1-202-727-00	CARBON	4.7M	5%	1/3W
R364	1-202-727-00	CARBON	4.7M	5%	1/3W
R365	1-202-727-00	CARBON	4.7M	5%	1/3W
R401	1-202-727-00	CARBON	4.7M	5%	1/3W
R402	1-247-713-11	CARBON	1K		1/4W
R403	1-247-692-11	CARBON	22	5%	1/4W
R404	1-247-692-11	CARBON	22	5%	1/4W
R405	1-247-717-11	CARBON	2.2K	5%	1/4W
R406	1-247-704-11	CARBON	220		1/4W
R407	1-247-700-11	CARBON	100		1/4W
R408	1-247-704-11	CARBON	220		1/4W
R409	1-247-704-11	CARBON	220		1/4W
R410	1-246-545-00	CARBON	1M		1/4W
R412	△ 1-217-440-00	FUSIBLE	33	5%	1/2W F
R413	1-249-490-11	CARBON	27K	5%	1/2W
R414	1-247-704-11	CARBON	220	5%	1/4W
R415	1-246-531-00	CARBON	270K		1/4W
R416	1-247-740-11	CARBON	120		1/2W
R417	1-249-496-11	CARBON	12K		1/2W
R418	1-247-764-11	CARBON	10K		1/2W
R419	1-202-727-00	CARBON	4.7M	5%	1/3W
R420	1-247-715-11	CARBON	1.5K	5%	1/4W
R421	1-247-721-11	CARBON	4.7K	5%	1/4W
R422	△ 1-217-446-00	FUSIBLE	100	5%	1/2W F
R423	△ 1-247-710-11	CARBON	560	5%	1/4W
R424	1-247-718-11	CARBON	2.7K	5%	1/4W
R425	1-247-710-11	CARBON	560	5%	1/4W
R426	△ 1-217-454-00	FUSIBLE	470	5%	1/2W F
R427	△ 1-217-434-00	FUSIBLE	10	5%	1/2W F
R428	△ 1-217-434-00	FUSIBLE	10	5%	1/2W F
R429	△ 1-217-446-00	FUSIBLE	100	5%	1/2W F
R430	△ 1-217-434-00	FUSIBLE	10	5%	1/2W F
R431	△ 1-217-434-00	FUSIBLE	10	5%	1/2W F
R432	△ 1-217-434-00	FUSIBLE	10	5%	1/2W F
R433	△ 1-217-434-00	FUSIBLE	10	5%	1/2W F
R434	△ 1-217-151-00	RES, METAL PLATE 0.22			
R435	△ 1-217-151-00	RES, METAL PLATE 0.22			
R436	△ 1-217-151-00	RES, METAL PLATE 0.22			
R437	△ 1-217-151-00	RES, METAL PLATE 0.22			
R438	△ 1-247-692-11	CARBON	22	5%	1/4W F
R439	△ 1-247-692-11	CARBON	22	5%	1/4W F
R440	△ 1-247-715-11	CARBON	1.5K	5%	1/4W F
R441	1-249-460-11	CARBON	15K	5%	1/4W
R442	△ 1-217-582-00	CEMENTED	8.2	10%	5W
R443	1-247-727-11	CARBON	10	5%	1/2W
R444	△ 1-217-446-00	FUSIBLE	100	5%	1/2W F
R445	△ 1-217-446-00	FUSIBLE	100	5%	1/2W F
R446	△ 1-216-431-11	METAL OXIDE	560	5%	1W F
R447	△ 1-217-426-00	FUSIBLE	2.2	5%	1/2W F
R448	△ 1-217-426-00	FUSIBLE	2.2	5%	1/2W F
R449	△ 1-247-688-11	(G-AEP)...CARBON	10	5%	1/4W F
R451	1-202-727-00	CARBON	4.7M	5%	1/3W
R452	1-247-713-11	CARBON	1K		1/4W

ELECTRICAL PARTS

Ref.No.	Part No.	Description			
R453	1-247-692-11	CARBON	22	5%	1/4W
R454	1-247-692-11	CARBON	22	5%	1/4W
R455	1-247-717-11	CARBON	2.2K	5%	1/4W
R456	1-247-704-11	CARBON	220		1/4W
R457	1-247-700-11	CARBON	100		1/4W
R458	1-247-704-11	CARBON	220		1/4W
R459	1-247-704-11	CARBON	220		1/4W
R460	1-246-545-00	CARBON	1M		1/4W
R462	△ 1-217-440-00	FUSIBLE	33	5%	1/2W F
R463	1-249-490-11	CARBON	27K	5%	1/2W
R464	1-247-704-11	CARBON	220	5%	1/4W
R465	1-246-531-00	CARBON	270K		1/4W
R466	1-247-740-11	CARBON	120		1/2W
R467	1-249-486-11	CARBON	12K		1/2W
R468	1-247-764-11	CARBON	10K		1/2W
R469	1-202-727-00	CARBON	4.7M	5%	1/3W
R470	1-247-715-11	CARBON	1.5K	5%	1/4W
R471	1-247-721-11	CARBON	4.7K	5%	1/4W
R472	△ 1-217-446-00	FUSIBLE	100	5%	1/2W F
R473	△ 1-247-710-11	CARBON	560	5%	1/4W
R474	1-247-718-11	CARBON	2.7K	5%	1/4W
R475	1-247-710-11	CARBON	560	5%	1/4W
R476	△ 1-217-454-00	FUSIBLE	470	5%	1/2W F
R477	△ 1-217-434-00	FUSIBLE	10	5%	1/2W F
R478	△ 1-217-434-00	FUSIBLE	10	5%	1/2W F
R479	△ 1-217-446-00	FUSIBLE	100	5%	1/2W F
R480	△ 1-217-434-00	FUSIBLE	10	5%	1/2W F
R481	△ 1-217-434-00	FUSIBLE	10	5%	1/2W F
R482	△ 1-217-434-00	FUSIBLE	10	5%	1/2W F
R483	△ 1-217-434-00	FUSIBLE	10	5%	1/2W F
R484	△ 1-217-151-00	RES, METAL PLATE 0.22			
R485	△ 1-217-151-00	RES, METAL PLATE 0.22			
R486	△ 1-217-151-00	RES, METAL PLATE 0.22			
R487	△ 1-217-151-00	RES, METAL PLATE 0.22			
R488	△ 1-247-692-11	CARBON	22	5%	1/4W F
R489	△ 1-247-692-11	CARBON	22	5%	1/4W F
R490	△ 1-247-715-11	CARBON	1.5K	5%	1/4W F
R491	1-249-460-11	CARBON	15K	5%	1/4W
R492	△ 1-217-582-00	CEMENTED	8.2	10%	5W
R493	1-247-727-11	CARBON	10	5%	1/2W
R494	△ 1-217-446-00	FUSIBLE	100	5%	1/2W F
R495	△ 1-217-446-00	FUSIBLE	100	5%	1/2W F
R496	△ 1-216-431-11	METAL OXIDE	560	5%	1W F
R497	△ 1-217-426-00	FUSIBLE	2.2	5%	1/2W F
R498	△ 1-217-426-00	FUSIBLE	2.2	5%	1/2W F
R499	△ 1-247-688-11	(G-AEP)...CARBON	10	5%	1/4W F
R504	1-247-724-11	CARBON	8.2K	5%	1/4W
R505	△ 1-247-120-00	CARBON	360	5%	1/4W F
R506	△ 1-216-430-11	METAL OXIDE	390	5%	1W F
R507	△ 1-213-142-00	METAL OXIDE	820	5%	1W F
R601	1-246-533-00	CARBON	330K		1/4W
R602	1-246-529-00	CARBON	220K		1/4W
R603	1-247-725-11	CARBON	10K	5%	1/4W
R604	1-246-533-00	(G-AEP)...CARBON	330K		1/4W
R604	1-249-461-11	(EXCEPT FOR G-AEP) ...CARBON	18K	5%	1/4W

The components identified by shading and mark △ are critical for safety. Replace only with part number specified.

Les composants identifiés par une trame et une marque △ sont critiques pour la sécurité. Ne les remplacer que par une pièce portant le numéro spécifié.

TA-F444ESX/F700ES

ELECTRICAL PARTS

Ref.No.	Part No.	Description				
R605	1-246-531-00	CARBON	270K	5%	1/4W	
R606	1-249-460-11	CARBON	15K	5%	1/4W	
R607	1-249-462-11	CARBON	22K	5%	1/4W	
R608	1-249-462-11	CARBON	22K	5%	1/4W	
R609	1-247-721-11	CARBON	4.7K	5%	1/4W	
R610	△1-206-640-00	METAL OXIDE	100	5%	2W	F
R611	△1-206-640-00	METAL OXIDE	100	5%	2W	F
R612	△1-213-131-00	METAL OXIDE	100	5%	1W	F
R614	△1-249-489-11	CARBON	22K	5%	1/2W	F
R615	△1-216-455-11	METAL OXIDE	560	5%	2W	F
R616	△1-216-455-11	METAL OXIDE	560	5%	2W	F
R617	△1-213-132-00	METAL OXIDE	120	5%	1W	F
R618	△1-213-141-00	METAL OXIDE	680	5%	1W	F
R619	1-249-462-11	CARBON	22K	5%	1/4W	
R620	1-249-462-11	CARBON	22K	5%	1/4W	
R621	1-247-128-00	CARBON	750	5%	1/4W	
R630	△1-217-434-00	(G-AEP)...FUSIBLE	10	5%	1/2W	F
R651	1-246-533-00	CARBON	330K		1/4W	
R680	△1-217-434-00	(G-AEP)...FUSIBLE	10	5%	1/2W	F
R701	△1-213-086-00	FUSIBLE	120	5%	1W	F
R751	△1-213-086-00	FUSIBLE	120	5%	1W	F
RT401	1-224-550-21	RES, ADJ, SOLID 220 (OFF SET)				
RT402	1-224-248-XX	RES, ADJ, SOLID 470 (BIAS)				
RT451	1-224-550-21	RES, ADJ, SOLID 220 (OFF SET)				
RT452	1-224-248-XX	RES, ADJ, SOLID 470 (BIAS)				
RY201	1-515-495-00	RELAY				
RY301	1-515-495-00	RELAY				
RY601	1-515-503-00	RELAY				
RY602	1-515-356-00	RELAY				
RY603	1-515-356-00	RELAY				
S101	1-554-879-11	SWITCH, SLIDE (INPUT SELECTOR)				
S102	1-570-593-11	SWITCH, SLIDE (REMOTE TYPE) (TAPE SELECTOR)				
S103	1-570-076-11	SWITCH, SLIDE (REMOTE TYPE) (REC OUT SELECTOR)				
S104	1-516-785-XX	SWITCH, SLIDE (ADAPTOR)				
S201	1-554-019-00	SWITCH, SLIDE (REMOTE TYPE) (CARTRIDGE LOAD)				
S301	1-570-594-11	SWITCH, PUSH (2 KEY) (MUTING)				
S302	1-570-595-11	SWITCH, PUSH (1 KEY) (SUB SONIC)				
S303	1-570-596-11	SWITCH, PUSH (3 KEY) (TONE)				
S304	1-570-594-11	SWITCH, PUSH (2 KEY) (SOURCE DIRECT)				
S305	1-570-596-11	SWITCH, PUSH (3 KEY) (TURNOVER)				
S306	1-570-596-11	SWITCH, PUSH (3 KEY) (TURNOVER)				
S501	1-570-592-11	SWITCH, ROTARY (MODE)				
S601	1-554-876-11	SWITCH, ROTARY (SPEAKER)				

ELECTRICAL PARTS

Ref.No.	Part No.	Description
S801	△1-552-084-00	(E)...SWITCH, PUSHBUTTON (POWER)
S801	△1-552-246-00	(US,Canadian)...SWITCH, PUSHBUTTON (POWER)
S801	△1-554-880-11	(AEP,G-AEP,UK)...SWITCH, PUSHBUTTON (POWER)
T1	△1-448-631-11	(UK,G-AEP)...TRANSFORMER, POWER
T1	△1-448-632-11	(E)...TRANSFORMER, POWER
T1	△1-448-633-11	(US,Canadian)...TRANSFORMER, POWER
T1	△1-448-634-11	(AEP)...TRANSFORMER, POWER
VR301	1-237-113-11	RES, VAR, CARBON 150K/150K (BALANCE)
VR302	1-237-174-11	RES, VAR, CARBON 250K/250K (TREBLE)
VR303	1-237-173-11	RES, VAR, CARBON 1M/500K/1M/500K (BASS)
VR304	1-237-175-11	RES, VAR, CARBON 120K/120K (ATTENUATOR)
VS801	△1-526-576-31	(E)...SELECTOR, POWER VOLTAGE

ACCESSORY & PACKING MATERIAL

Part No.	Description
△1-526-565-00	(E)...AC PLUG ADAPTOR
2-297-403-00	SHEET (LARGE), PROTECTION
3-701-630-00	BAG, POLYETHYLENE
3-765-111-12	MANUAL, INSTRUCTION
4-908-877-01	CUSHION
4-908-883-01	SPACER
4-908-893-01	(E)...INDIVIDUAL CARTON
4-916-749-01	(EXCEPT FOR E)...INDIVIDUAL CARTON

The components identified by shading and mark △ are critical for safety. Replace only with part number specified.	Les composants identifiés par une trame et une marque △ sont critiques pour la sécurité. Ne les remplacer que par une pièce portant le numéro spécifié.
---	---

Sony Corporation
Audio Group