

# TA-F419R/F519R

## SERVICE MANUAL

AEP Model



Photo : TA-F519R

### SPECIFICATIONS

#### Amplifier

Continuous RMS power output (both channels driven simultaneously)

Model for Germany

		TA-F519R	TA-F419R
DIN, 1 kHz	4 ohms	105 W + 105 W	80 W + 80 W
	8 ohms	85 W + 85 W	75 W + 75 W
20 Hz - 20 kHz	4 ohms	80 W + 80 W	75 W + 75 W
	8 ohms	75 W + 75 W	65 W + 65 W

Model for Scandinavian countries, Switzerland, Spain and Portugal

		TA-F519R	TA-F419R
DIN, 1 kHz	6 ohms	100 W + 100 W	80 W + 80 W
	8 ohms	80 W + 80 W	70 W + 70 W
20 Hz - 20 kHz	6 ohms	75 W + 75 W	70 W + 70 W
	8 ohms	70 W + 70 W	60 W + 60 W

Model for other countries

		TA-F519R	TA-F419R
DIN, 1 kHz	4 ohms	105 W + 105 W	80 W + 80 W
	8 ohms	85 W + 85 W	75 W + 75 W
20 Hz - 20 kHz	4 ohms	80 W + 80 W	75 W + 75 W
	8 ohms	75 W + 75 W	65 W + 65 W

#### Input

Input jack	Jack type	Sensitivity	Impedance
PHONO (MM)	Phono	2.0 mV	50 kilohms
PHONO (MC)	Phono	0.17 mV	100 ohms
TUNER, CD, AUX, DAT/TAPE 1 TAPE 2	Phono	150 mV	50 kilohms

PHONO (MM/MC): only for TA-F519R

#### S/N

	TA-F519R	TA-F419R
PHONO (MM)	76 dB	—
PHONO (MC)	94 dB	94 dB
TUNER, CD, AUX, DAT/TAPE 1 TAPE 2	103 dB	103 dB

#### Output

Output jack	Jack type	Voltage/impedance
REC OUT	Phono jack	Voltage 150 mV Impedance 1 kohm
HEADPHONES	Stereo phono jack	Accepts low and high impedance headphones

INTEGRATED STEREO AMPLIFIER  
**SONY**®

Tone controls

	Response	Turnover frequency
BASS	±7 dB (100 Hz)	300 Hz
TREBLE	±6 dB (10 kHz)	5 kHz

Harmonic distortion	Less than 0.008% at 10 W output
Intermodulation (IM) distortion (60 Hz : 7 kHz = 4:1)	Less than 0.008% at 10 W output
Frequency response	PHONO: RIAA equalization curve ±0.5 dB TUNER, CD, AUX, DAT/TAPE 1, TAPE 2: 7 Hz – 100 kHz ±3 dB
Residual noise	Less than 170 µV (network A)
Damping factor	70 (8 ohms, 1 kHz)

**General**

System	Preamplifier: Low-noise, equalizer amplifier Power amplifier: Pure-complementary SEPP OCL power amplifier with all stages directly coupled
Power requirements	220 V – 230 V AC, 50/60 Hz
Power consumption	Model for Germany TA-F 519R: 160 W TA-F 419R: 160 W Model for Scandinavian countries, Switzerland, Spain and Portugal TA-F 519R: 160 W TA-F 419R: 160 W Model for other European countries TA-F 519R: 260 W TA-F 419R: 260 W
Dimensions	Approx. 430 x 150 x 375 mm (w/h/d) (17 x 5 7/8 x 14 3/4 inches)
Weight	TA-F519R: Approx. 9.1 kg (20 lb 1 oz) TA-F419R: Approx. 8.6 kg (18 lb 15 oz)
Supplied accessories	Remote commander RM-S311 (1) Sony SUM-3 (NS) batteries (2)

The above values are measured at 230 V AC. (Models for European countries)

Design and specifications are subject to change without notice.

Note

This appliance conforms with EEC Directive 87/308/EEC regarding interference suppression.

**TABLE OF CONTENTS**

Section	Title	Page
	Specifications .....	1
<b>1. GENERAL</b>	.....	3
<b>2. ELECTRICAL ADJUSTMENTS</b>	.....	4
<b>3. DIAGRAMS</b>		
	3-1. Circuit Boards Location .....	4
	3-2. Block Diagram .....	5
	3-3. Printed Wiring Boards (KEY BOARD SECTION) .....	8
	3-4. Printed Wiring Boards (MAIN BOARD SECTION) .....	11
	3-5. Schematic Diagram .....	15
	3-6. IC Block Diagram .....	19
<b>4. EXPLODED VIEWS</b>		
	4-1. Front Panel Section .....	20
	4-2. Chassis Section-1 .....	21
	4-3. Chassis Section-2 .....	22
<b>5. ELECTRICAL PARTS LIST</b>	.....	23

**SAFETY-RELATED COMPONENT WARNING!!**

**COMPONENTS IDENTIFIED BY MARK  $\Delta$  OR DOTTED LINE WITH MARK  $\Delta$  ON THE SCHEMATIC DIAGRAMS AND IN THE PARTS LIST ARE CRITICAL TO SAFE OPERATION. REPLACE THESE COMPONENTS WITH SONY PARTS WHOSE PART NUMBERS APPEAR AS SHOWN IN THIS MANUAL OR IN SUPPLEMENTS PUBLISHED BY SONY.**

## SECTION 1 GENERAL

### Identifying the Parts and Controls

This section describes about each name of this amplifier and remote commander.

This section is extracted from instruction manual.

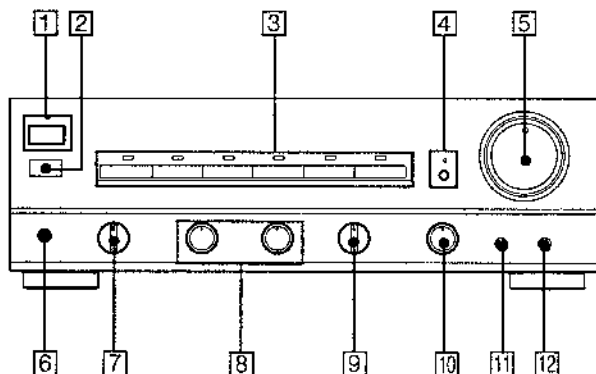

#### Front Panel

- 1 POWER switch and STANDBY indicator
- 2 Remote control sensor
- 3 Function selectors and indicators
- 4 SOURCE DIRECT button and indicator
- 5 VOLUME control and indicator  
Adjusts the sound level.  
Immediately after turning on the POWER switch, the VOLUME indicator blinks when the built-in muting circuit activates and the unit detects shorting of circuit of the speaker outputs or in case of short-circuit of the inputs of DC components. In such case, turn off the unit and check the connected components and speaker system.
- 6 HEADPHONES jack
- 7 SPEAKERS selector
- 8 TONE (BASS/TREBLE) controls
- 9 REC OUT SELECTOR
- 10 BALANCE control
- 11 SUBSONIC switch (TA-F519R)
- 12 CARTRIDGE selector (TA-F519R)

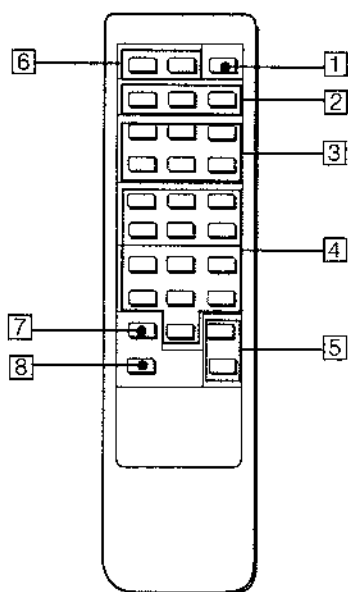

RM-S311

#### Remote Commaner

- 1 POWER switch
- 2 TUNER operation buttons  
TUNER: Select the TUNER mode.  
PRESET +/- buttons: Select the preset station.
- 3 CD operation buttons  
◀▶: Automatic music sensor.  
D. (Disc) SKIP: Disc skip (for CD player equipped with a multi-disc changer)  
▶: The amplifier enters the CD mode and the CD player starts playback automatically.  
■: Stop.  
⏸: Pause.
- 4 TAPE 2 DECK A/DECK B operation buttons  
◀▶: Fast winding.  
■: Stop.  
◀: The amplifier enters the TAPE 2 mode and the tape deck starts reverse playback automatically.  
▶: The amplifier enters the TAPE 2 mode and the tape deck starts forward playback automatically.  
●: Recording.  
⏸: Pause. (Only for DECK B)
- 5 VOL (Volume) +/- buttons
- 6 PHONO operation buttons  
START: Pressing START automatically selects the PHONO mode on the amplifier and starts playback of the turntable system.  
STOP: Stops playback of the turntable system.
- 7 DAT/TAPE 1 button  
Selects the DAT or TAPE 1 mode.
- 8 AUX button  
Selects the AUX mode.

## SECTION 2 ELECTRICAL ADJUSTMENTS

**Note :**

1. DC BIAS adjustments should be made one minute after the POWER switch is turned on (POWER ON).
2. After replacing the power transistors, DC BIAS adjustments should be made.

**DC Bias Adjustment (with no signal input)**

**Procedure :**

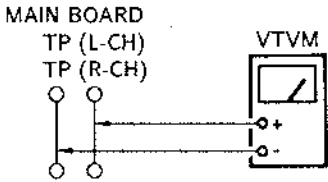

	Adjustment part	Reading on VTVM
L-CH	RV500	7mV
R-CH	RV600	7mV

**Adjustment Location :**

**[MAIN BOARD]**

— COMPONENT SIDE —

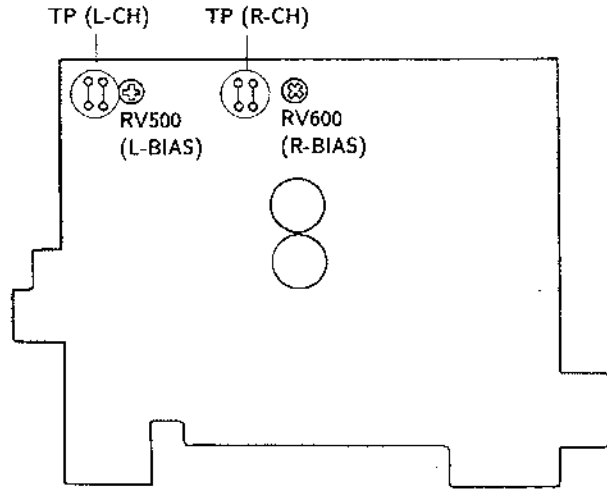

## SECTION 3 DIAGRAMS

**3-1. CIRCUIT BOARDS LOCATION**

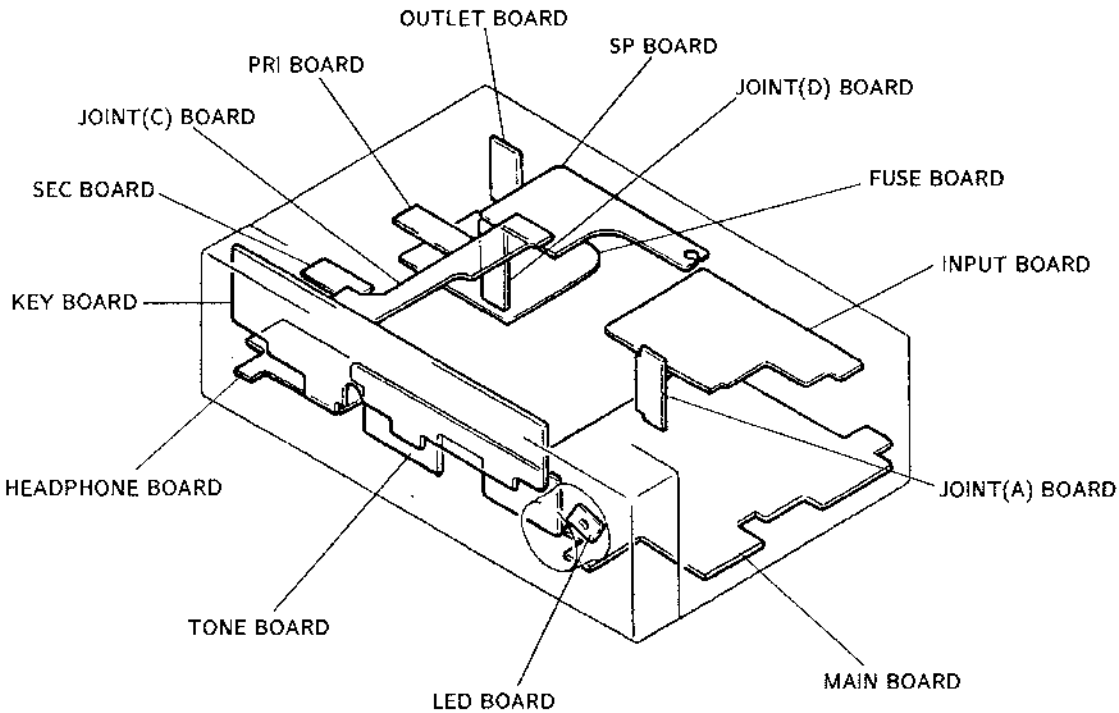

### 3-2. BLOCK DIAGRAM

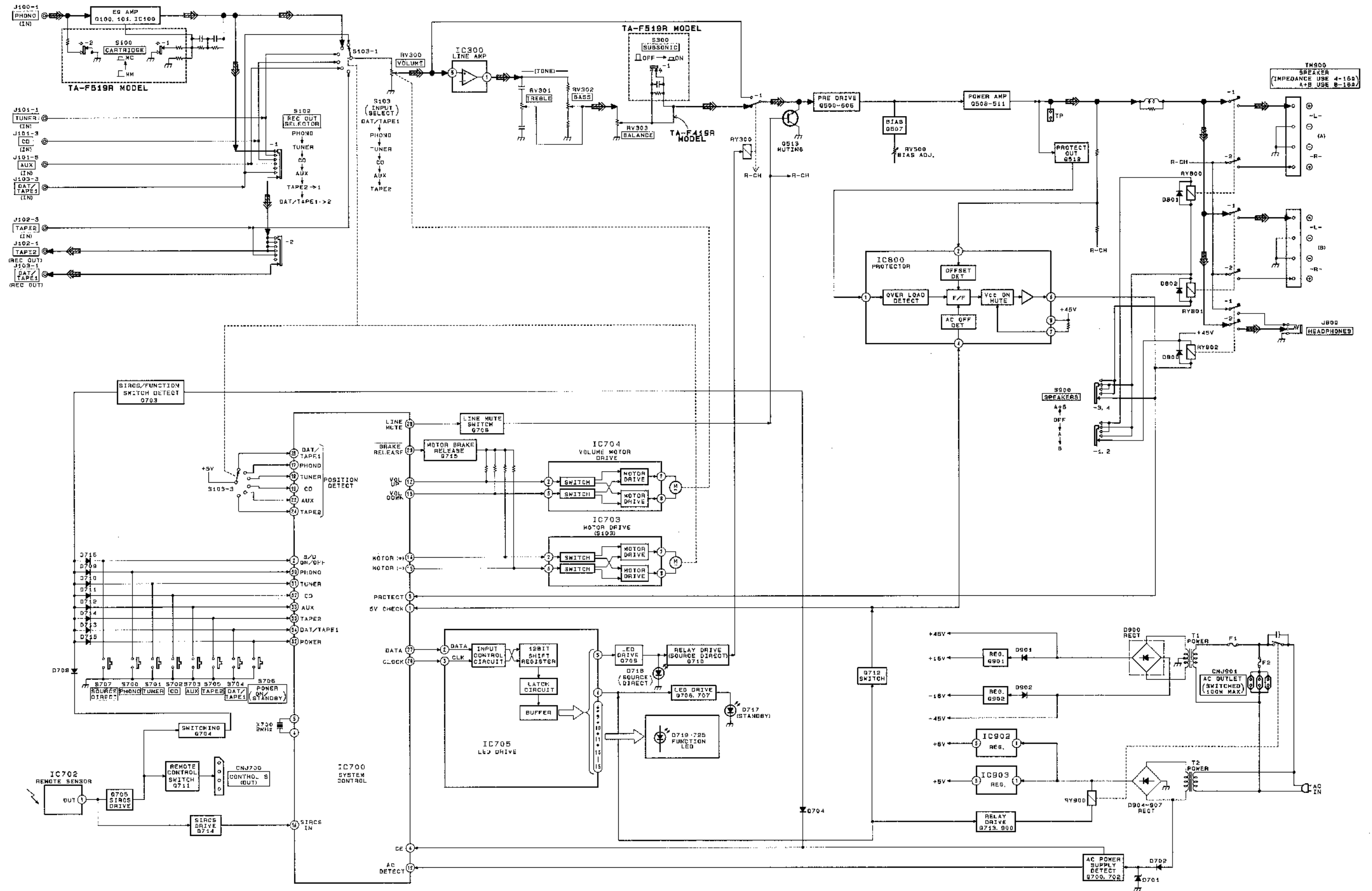

● IC700 System Controller (M50720-358SP)

Pin No.	Pin Name	I/O	Description
1	5V CHECK	I	Power supply (+5V) check.
2	S/D ON/OFF	I	Source direct ON/OFF control input.
3	PROTECT	I	Protection signal input.
4	X OUT	O	Connected oscillator circuit.
5	X IN	I	Connected oscillator circuit.
6	CE	I	Signal input for a return to normal position.
7	RESET	I	Reset signal input. ("L" : RESET)
8	VDD	I	+5 Volts power supply.
9	CNTR	I	Ground.
10	AC DET	I	AC power supply detection input.
11	C	I	Connected 0.1 $\mu$ F capacitor.
12	VOL UP	O	Volume control (up) signal output.
13	VOL DOWN	O	Volume control (down) signal output.
14	MOTOR NORM	O	Motor (normal turn) signal output.
15	MOTOR RVS	O	Motor (reverse turn) signal output.
16	SIRCS IN	I	Serial data input (SIRCS).
17	S1	I	Function selector positioning detection input (PHONO).
18	S2	I	Function selector positioning detection input (TUNER).
19	S3	I	Function selector positioning detection input (CD).
20	CNVSS	—	Ground.
21	VSS	—	Ground.
22	S4	I	Function selector positioning detection input (AUX).
23	S5	I	Function selector positioning detection input (TAPE 1).
24	S6	I	Function selector positioning detection input (TAPE 2).
25	S7	I	Connected the resistor 22 kilohms.
26	CLOCK	O	Shift register for LED (CLK).
27	DATA	O	Shift register for LED (DATA).
28	LINE MUTE	O	Line mute signal output.
29	BRAKE RELEASE	O	Motor drive control signal output. ("L" : BRAKE RELEASE)
30	PHONO	I	Function control input for Phono mode.
31	TUNER	I	Function control input for Tuner mode.
32	CD	I	Function control input for CD mode.
33	AUX	I	Function control input for AUX mode.
34	TAPE1	I	Function control input for Tape 1 mode.
35	TAPE2	I	Function control input for Tape 2 mode.
36	—	—	Connected the resistor 22 kilohms.
37	POWER ON/OFF	I	Power ON/OFF control input.
38	K0	I	Ground.
39	K1	I	Ground.
40	K2	I	Microcomputer operation mode selection input.
41	K3	I	Microcomputer operation mode selection input.
42	MUTE	I	Connected the resistor 22 kilohms.

• SEMICONDUCTOR LEAD LAYOUTS

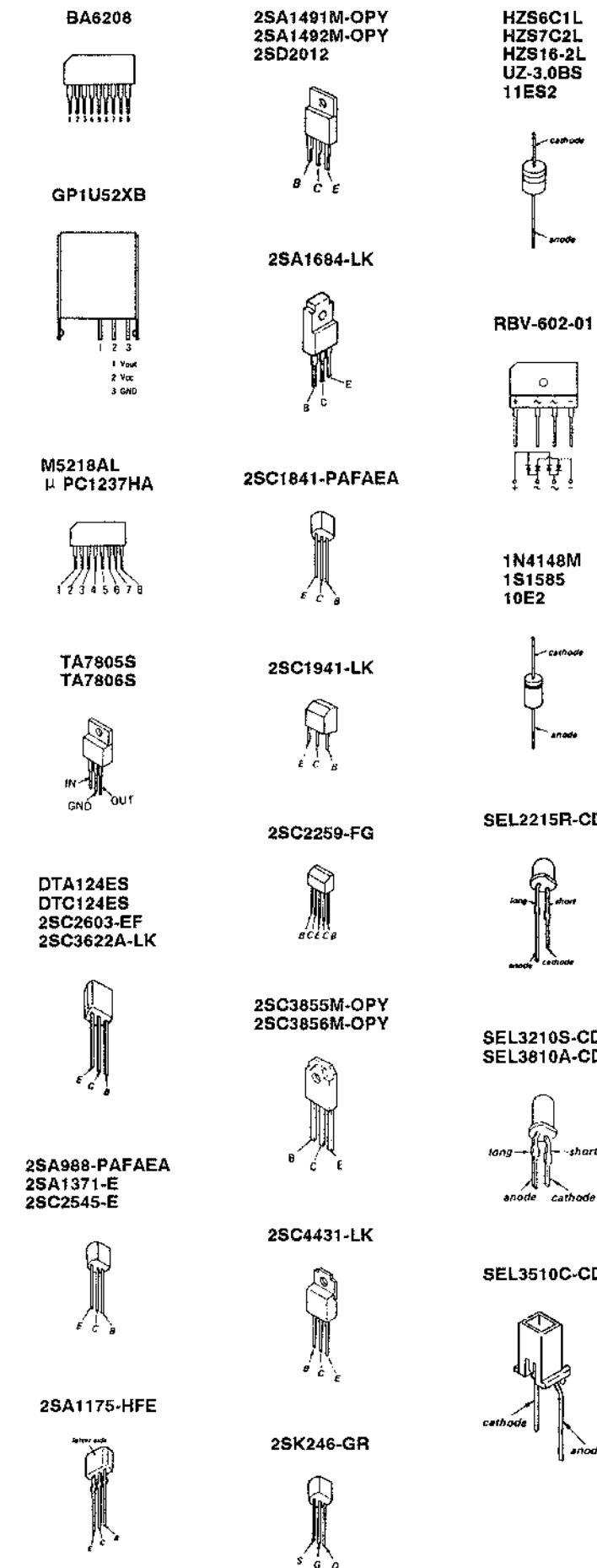

• SEMICONDUCTOR LOCATION

Ref. No.	Location
D703	I-9
D704	I-9
D708	I-5
D709	H-13
D710	H-13
D711	H-11
D712	H-10
D713	H-7
D714	H-9
D715	H-6
D716	H-13
D717	J-4
D718	H-16
D719	E-13
D720	H-8
D721	H-6
D722	H-9
D723	H-11
D724	H-12
D725	H-14
D800	E-4
IC702	H-4
IC705	I-12
Q700	I-9
Q701	I-8
Q702	I-8
Q703	I-10
Q704	H-6
Q705	H-5
Q706	I-5
Q707	I-5
Q709	I-13

Note:

- : parts extracted from the component side.
- ⋯ : Pattern on the side which is seen.

3-3. PRINTED WIRING BOARDS (KEY BOARD SECTION)

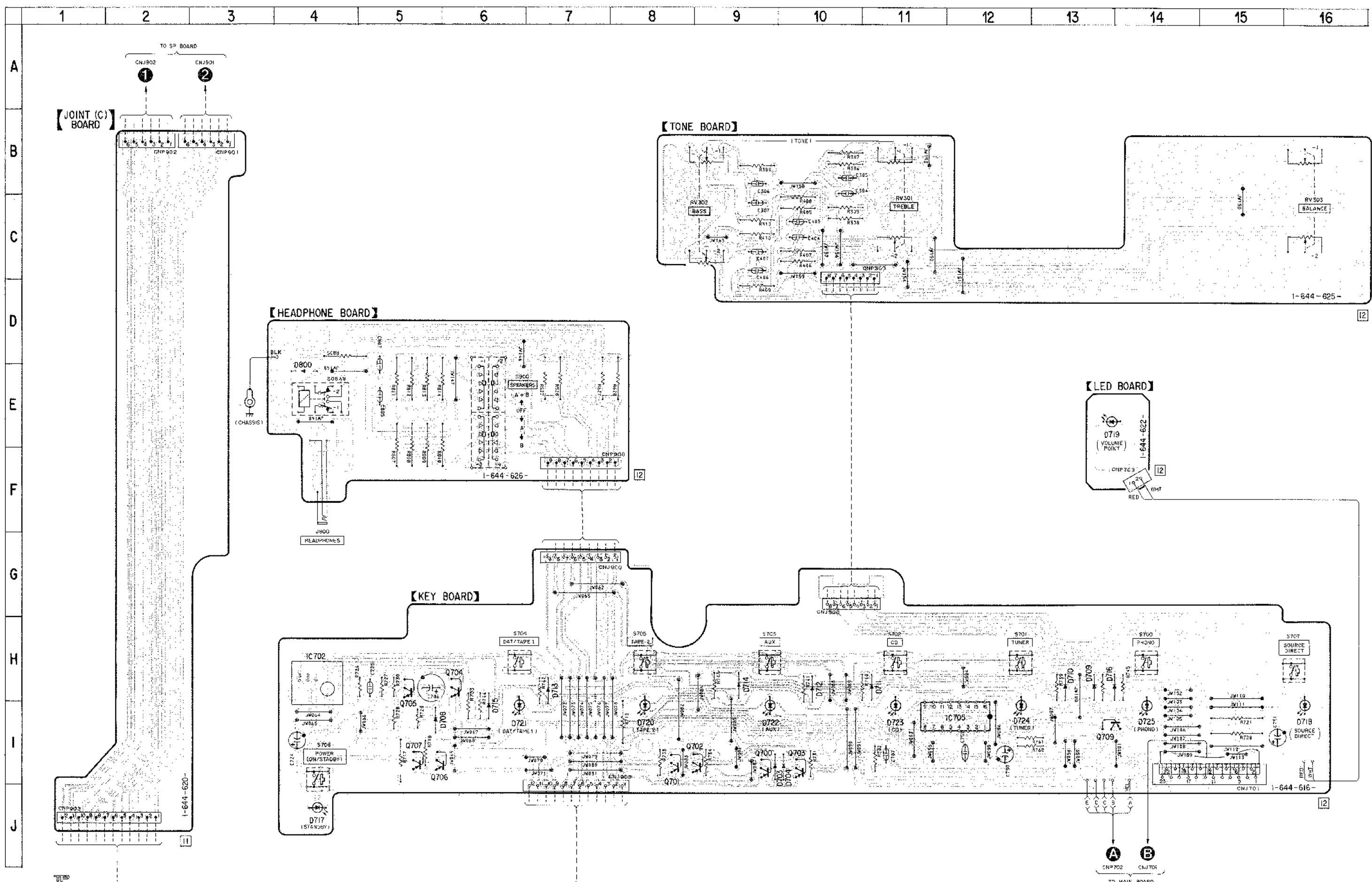

• SEMICONDUCTOR LOCATION

Ref. No.	Location	Ref. No.	Location	Ref. No.	Location
D100	C-24	D909	E-28	Q609	I-26
D500	H-21	D910	E-7	Q610	J-27
D501	H-19			Q611	J-25
D502	I-20			Q612	J-27
D503	I-20	IC100	D-25	Q613	E-23
		IC300	F-21		
D504	H-21	C700	D-22	O708	E-24
D505	H-21	C703	F-17	O710	E-23
D506	H-21	C704	F-17	O711	D-5
D507	I-20			O712	E-21
D508	I-22	IC800	F-20	O713	F-5
		IC902	D-5		
		IC903	E-5	O714	D-20
D509	I-22			O715	C-23
D600	H-28			Q900	E-6
D601	H-27			Q901	E-27
D602	H-26	Q100	C-26	Q902	F-27
D603	H-26	Q101	C-26		
		Q200	D-26		
		Q201	D-26		
		Q600	H-20		
D604	I-28				
D605	I-28				
D606	I-26	Q501	H-21		
D607	J-28	Q502	H-20		
		Q503	I-20		
		Q504	I-21		
		Q505	I-20		
D609	J-28				
D700	D-23				
D701	E-7				
D702	E-7	Q506	H-19		
D705	E-22	Q507	J-22		
		Q508	I-21		
		Q509	I-20		
		Q510	J-23		
D706	E-22				
D707	F-22				
D727	D-6				
D728	E-24	Q511	J-21		
D729	E-24	Q512	I-22		
		Q513	E-23		
D801	J-9	Q600	H-27		
D902	J-7	Q601	H-28		
D900	H-22				
D901	G-25	Q602	H-27		
D902	G-25	Q603	I-28		
		Q604	I-28		
		Q605	I-28		
D904	E-8	Q606	H-26		
D905	E-8				
D906	E-8				
D907	E-8	Q607	J-26		
D908	F-28	Q608	I-27		

3-4. PRINTED WIRING BOARDS (MAIN BOARD SECTION) • Refer to Page 8 for Semiconductor Lead Layouts.

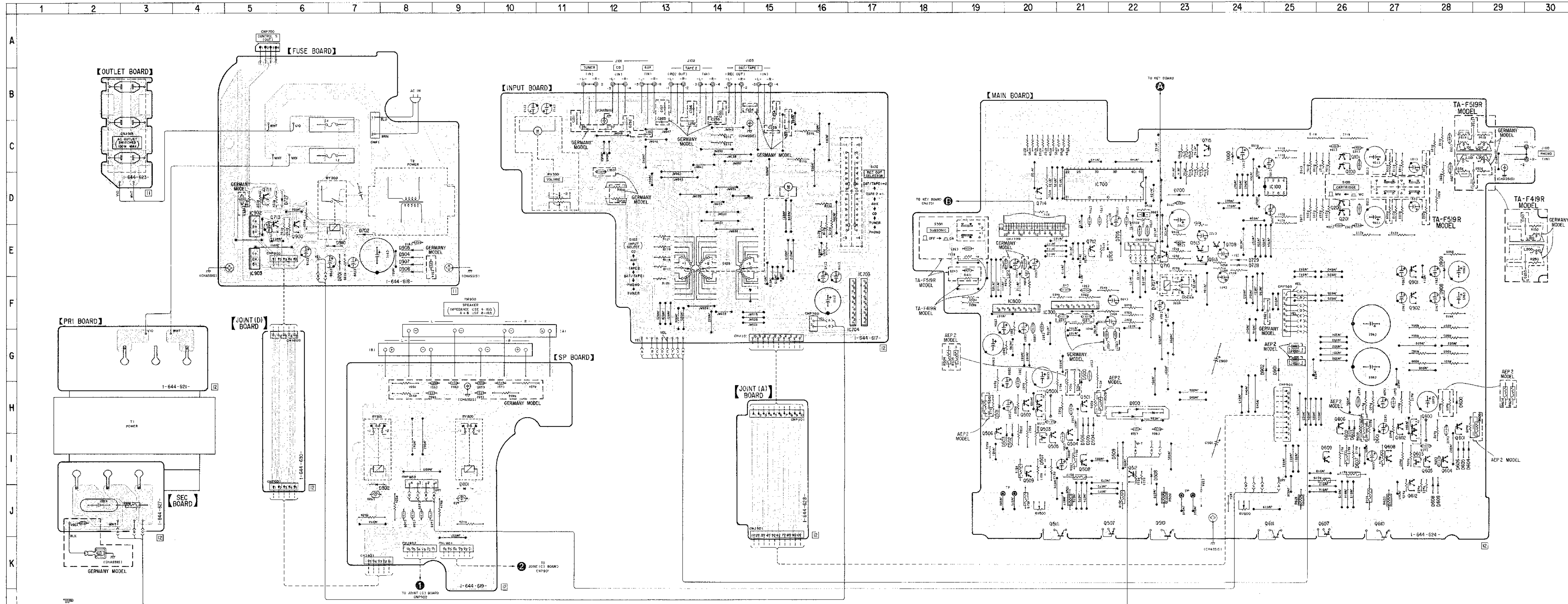



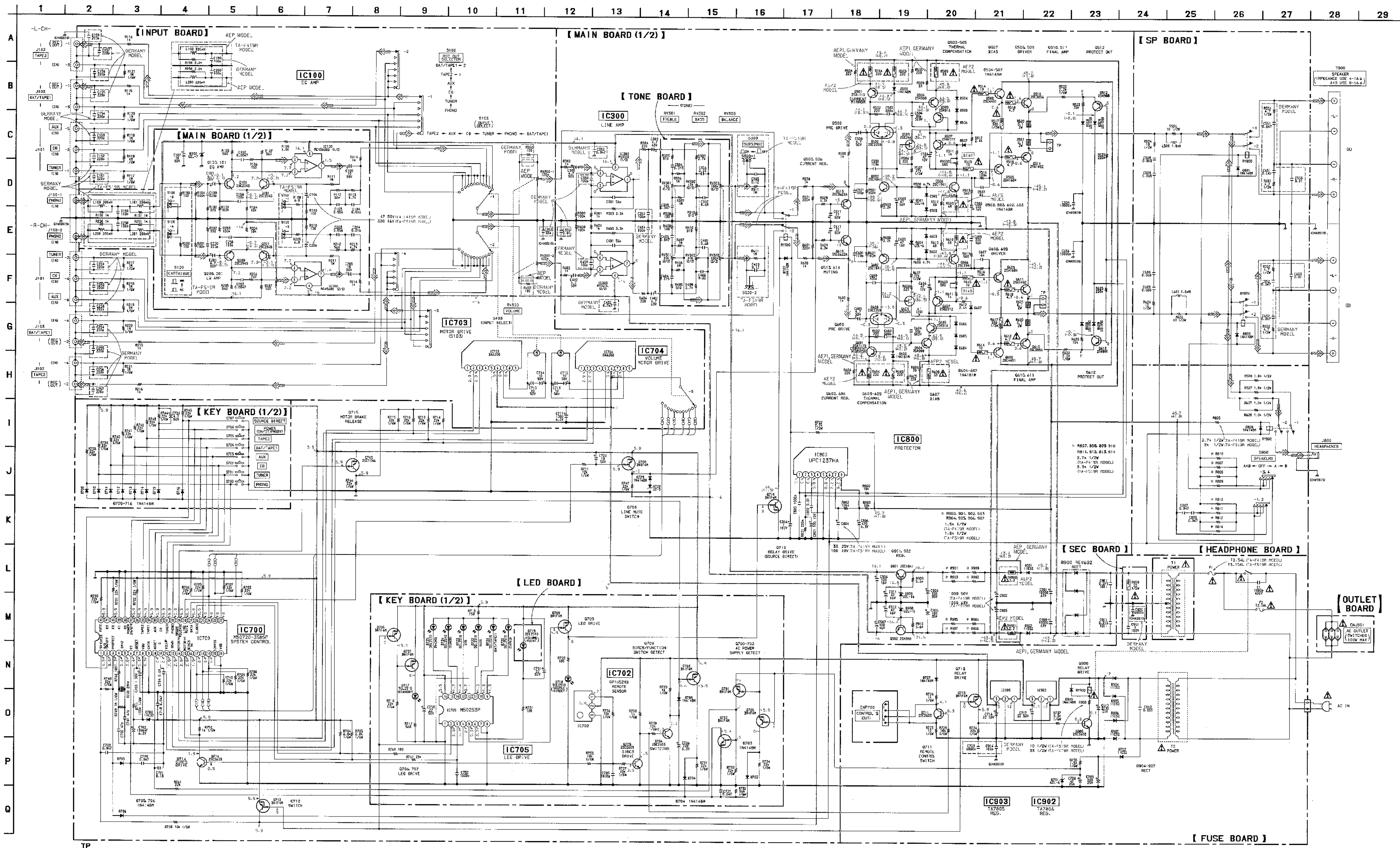

**Note :**

- All capacitors are in  $\mu\text{F}$  unless otherwise noted.  $\text{pF}$ :  $\mu\text{pF}$  50WV or less are not indicated except for electrolytics and tantalums.
- All resistors are in  $\Omega$  and  $\frac{1}{4}\text{W}$  or less unless otherwise specified.
- $\square$  : nonflammable resistor.
- $\square$  : fusible resistor.

**Note :** The components identified by mark  $\Delta$  or dotted line with mark  $\Delta$  are critical for safety. Replace only with part number specified.

- $\square$  : 6+ Line
- $\square$  : B - Line
- $\square$  : adjustment for repair.
- Voltage and waveforms are do with respect to ground under no-signal conditions. no mark : CD
- ( ) : F419R only
- Voltagas are taken with a VOM ( Input impedance 10M  $\Omega$  ). Voltage variations may be noted due to normal production tolerances.
- Signal path.
- $\square$  : PHONO

**Note :**

There are two type of AEP models which are depend on countries.

- AEP2 model : Model for Scandinavian countries, Switzerland, Spain and Portugal
- AEP1 model : Model for other European countries

3-6. IC BLOCK DIAGRAM

IC703, 704 BA6208

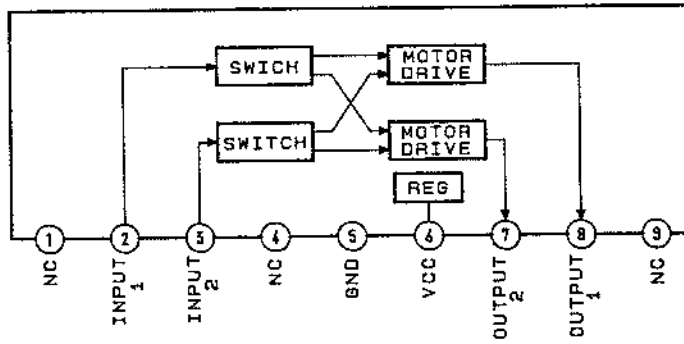

IC705 M50253P

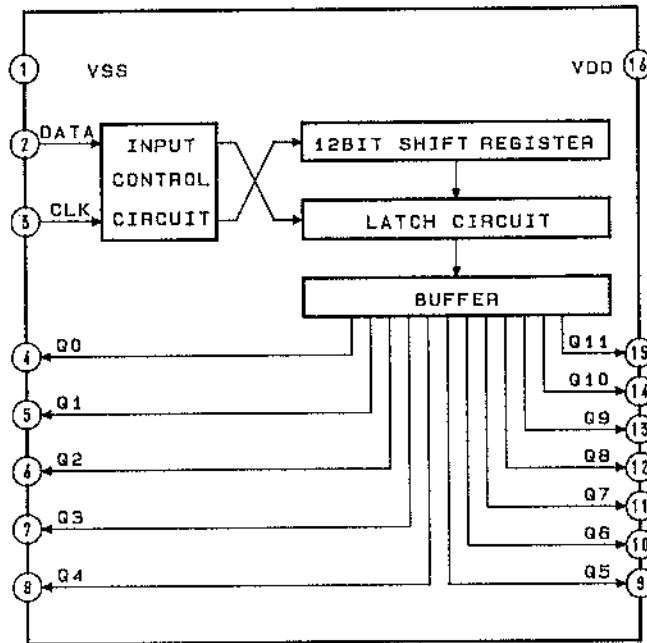

IC800 UPC1237HA

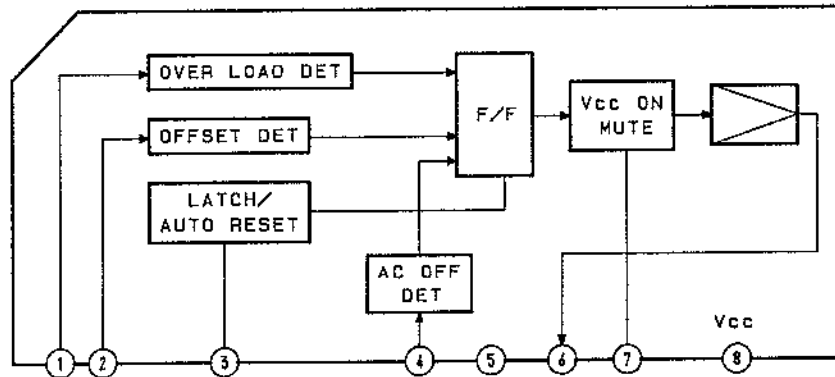

## SECTION 4 EXPLODED VIEWS

**NOTE:**

- -XX, -X mean standardized parts, so they may have some differences from the original one.
- The construction parts of an assembled part are indicated with a collation number in the remark column.
- Color indication of Appearance Parts  
Example:  
KNOB, BALANCE (WHITE).... (RED)

Parts color      Cabinet's color

- Items marked "\*" are not stocked since they are seldom required for routine service. Some delay should be anticipated when ordering these items.
- The mechanical parts with no reference number in the exploded views are not supplied.
- Hardware (# mark) list is given in the last of this parts list.

The components identified by mark **A** or dotted line with mark **A** are critical for safety. Replace only with part number specified.

When indicating parts by reference number, please include the board.

- There are two type of AEP models which are depend on countries.  
AEP2 model : Model for Scandinavian countries, Switzerland, Spain and Portugal  
AEP1 model : Model for other European countries

**4-1. FRONT PANEL SECTION**

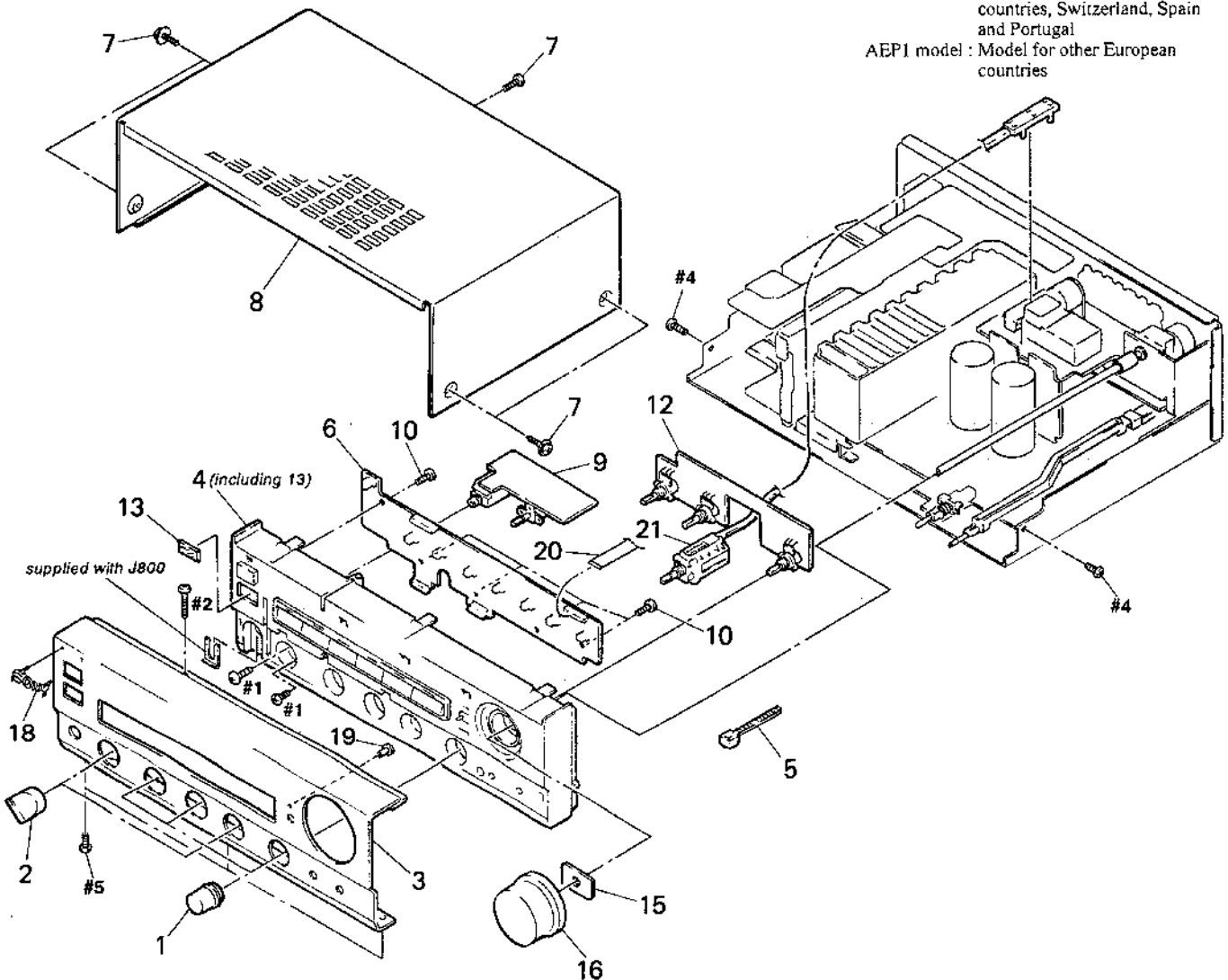

Ref. No.	Part No.	Description	Remark
1	4-949-931-01	KNOB (DIA. 21)	
2	4-951-344-01	KNOB (R21), FLAT	
3	4-951-336-01	PANEL, FRONT (F519R)	
3	4-951-336-11	PANEL, FRONT (F419R)	
4	X-4942-573-1	PANEL (BASE) ASSY	
5	3-655-653-21	BAND (TAITON), BINDING	
* 6	A-4347-648-A	KEY BOARD, COMPLETE (F419R:AEP/F519R:AEP)	
* 6	A-4347-649-A	KCY BOARD, COMPLETE (F419R:Germany/F519R:Germany)	

Ref. No.	Part No.	Description	Remark
8	4-931-031-11	CASE	
* 9	1-644-626-11	HEADPHONE BOARD	
10	4-951-620-01	SCREW (2. 6X8), BVTP	
* 12	1-644-625-11	TONE BOARD	
13	4-931-911-01	FILTER	
* 15	1-644-622-11	LED BOARD	
16	X-4942-575-1	KNOB (R53) ASSY	
17	3-704-366-01	SCREW (CASE) (M3X8)	
18	4-908-848-01	EMBLEM, SONY	
19	4-938-518-01	INDICATOR (C)	
20	1-590-499-31	WIRE, FLAT TYPE (23 CORE)	
21	1-692-148-11	SWITCH, ROTARY SLIDE	

4-2. CHASSIS SECTION-1

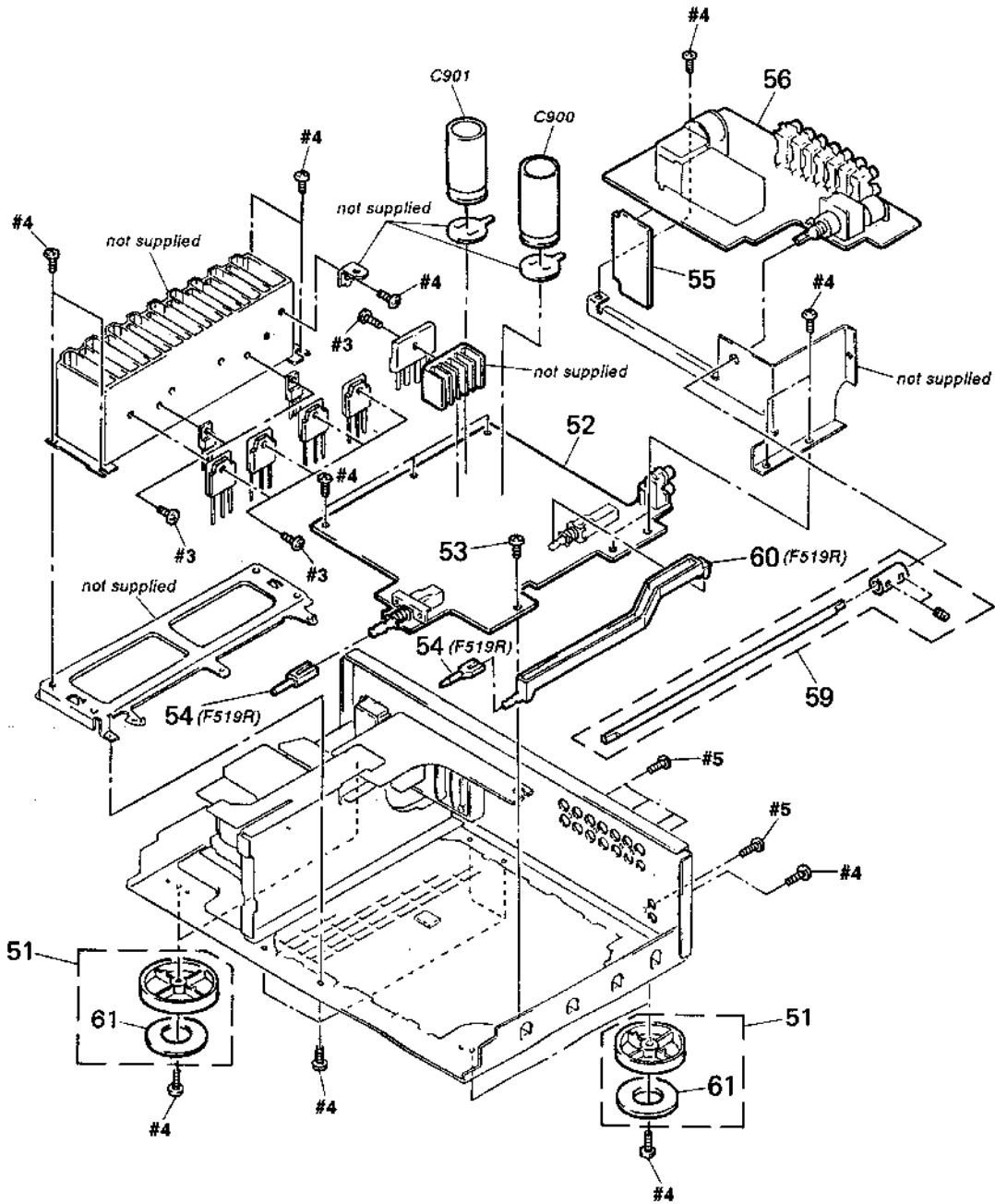

Ref. No.	Part No.	Description	Remark
51	X-3304-938-2	FOOT ASSY	
* 52	A-4347-636-A	MAIN BOARD, COMPLETE (F519R:AEP1)	
* 52	A-4347-637-A	MAIN BOARD, COMPLETE (F519R:AEP2)	
* 52	A-4347-638-A	MAIN BOARD, COMPLETE (F519R:Germany)	
* 52	A-4347-678-A	MAIN BOARD, COMPLETE (F419R:AEP1)	
* 52	A-4347-679-A	MAIN BOARD, COMPLETE (F419R:AEP2)	
* 52	A-4347-680-A	MAIN BOARD, COMPLETE (F419R:Germany)	
53	4-886-821-11	SCREW, S TIGHT, +PTWH 3X6	
54	4-931-641-01	BUTTON (DIA. 4) (F519R)	
* 55	1-644-628-11	JOINT (A) BOARD	

Ref. No.	Part No.	Description	Remark
* 56	A-4347-650-A	INPUT BOARD, COMPLETE (F419R:AEP/F519R:AEP)	
* 56	A-4347-651-A	INPUT BOARD, COMPLETE (F419R:Germany/F519R:Germany)	
59	X-4942-809-1	SHAFT ASSY	
* 60	4-951-345-01	ROD, PUSH SWITCH (F519R)	
61	4-923-836-11	CUSHION	

4-3. CHASSIS SECTION-2

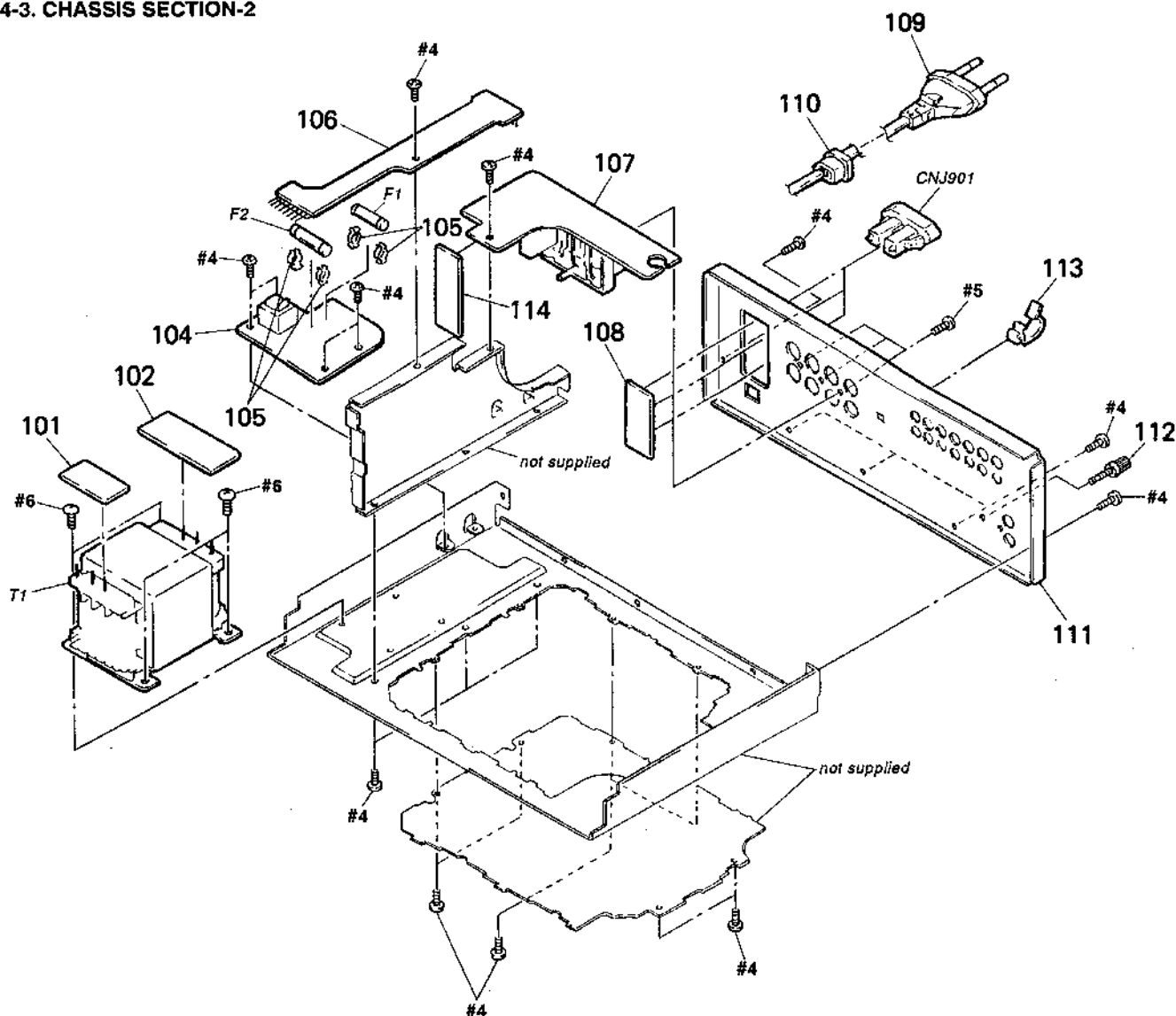

Note: The components identified by mark  $\Delta$  or dotted line with mark  $\Delta$  are critical for safety. Replace only with part number specified.

Ref. No.	Part No.	Description	Remark
* 101	1-644-627-11	SEC BOARD	
* 102	1-644-621-11	PRI BOARD	
* 104	A-4347-654-A	FUSE BOARD, COMPLETE (F519R:AEP)	
* 104	A-4347-655-A	FUSE BOARD, COMPLETE (F519R:Germany)	
* 104	A-4347-688-A	FUSE BOARD, COMPLETE (F419R:AEP)	
* 104	A-4347-689-A	FUSE BOARD, COMPLETE (F419R:Germany)	
* 105	1-533-213-31	HOLDER, FUSE	
* 106	1-644-620-11	JOINT (C) BOARD	
* 107	1-644-619-11	SP BOARD	
* 108	1-644-623-11	OUTLET BOARD	
$\Delta$ 109	1-575-651-11	CORD, POWER	
* 110	3-703-244-00	BUSHING (2104), CORD	
* 111	4-951-342-11	PANEL, BACK (F519R:AEP)	
* 111	4-951-342-21	PANEL, BACK (F519R:Germany)	
* 111	4-951-342-41	PANEL, BACK (F419R:AEP)	
* 111	4-951-342-51	PANEL, BACK (F419R:Germany)	

Ref. No.	Part No.	Description	Remark
112	4-947-010-01	SCREW, FEEDER FIXED	
* 113	4-949-235-01	HOOK	
* 114	1-644-630-11	JOINT (D) BOARD	
$\Delta$ CNJ901	1-526-794-11	OUTLET, AC	
$\Delta$ F1	1-532-237-00	FUSE, TIME LAG (T3, 15A) (F519R)	
$\Delta$ F1	1-532-286-00	FUSE (T2, 5A) (F419R)	
$\Delta$ F2	1-532-286-00	FUSE (T2, 5A)	
$\Delta$ T1	1-450-928-11	TRANSFORMER, POWER (F519R)	
$\Delta$ T1	1-450-929-11	TRANSFORMER, POWER (F419R:AEP1, Germany)	
$\Delta$ T1	1-450-930-12	TRANSFORMER, POWER (F419R:AEP2)	

SECTION 5  
ELECTRICAL PARTS LIST

FUSE

NOTE:

- Due to standardization, replacements in the parts list may be different from the parts specified in the diagrams or the components used on the set.
- -XX and -X mean standardized parts, so they may have some difference from the original one.
- RESISTORS  
All resistors are in ohms.  
METAL: Metal-film resistor.  
METAL OXIDE: Metal oxide-film resistor.  
F: nonflammable
- G: Germany
- AEP2: Model for Scandinavian countries, Switzerland, Spain and Portugal
- AEP1: Model for other European countries

- Items marked "\*" are not stocked since they are seldom required for routine service. Some delay should be anticipated when ordering these items.
- SEMICONDUCTORS  
In each case, u:  $\mu$ , for example:  
uA ..:  $\mu$ A.. uPA..:  $\mu$ PA..  
uPB..:  $\mu$ PB.. uPC..:  $\mu$ PC.. uPD..:  $\mu$ PD..
- CAPACITORS  
uF:  $\mu$ F
- COILS  
uH:  $\mu$ H

The components identified by mark  $\Delta$  or dotted line with mark  $\Delta$  are critical for safety. Replace only with part number specified.

When indicating parts by reference number, please include the board.

Ref. No.	Part No.	Description	Remark	Ref. No.	Part No.	Description	Remark
*	A-4347-654-A	FUSE BOARD, COMPLETE (F519R:AEP)		D905	8-719-200-82	DIODE 11ES2	
*	A-4347-655-A	FUSE BOARD, COMPLETE (F519R:G)		D906	8-719-200-82	DIODE 11ES2	
*	A-4347-688-A	FUSE BOARD, COMPLETE (F419R:AEP)		D907	8-719-200-82	DIODE 11ES2	
*	A-4347-689-A	FUSE BOARD, COMPLETE (F419R:G)		D910	8-719-987-63	DIODE 1N4148M	
*****							
*	1-533-213-31	HOLDER, FUSE		< FUSE >			
< CAPACITOR >							
$\Delta$ C1	1-161-741-00	CERAMIC	0.001uF 10% 400V	$\Delta$ F1	1-532-237-00	FUSE, TIME LAG (T3. 15A) (F519R)	
C708	1-124-126-00	ELECT	47uF 20% 10V	$\Delta$ F1	1-532-286-00	FUSE (T2. 5A) (F419R)	
C709	1-124-478-11	ELECT	100uF 20% 25V	$\Delta$ F2	1-532-286-00	FUSE (T2. 5A)	
C716	1-126-233-11	ELECT	22uF 20% 50V	< IC >			
C717	1-126-233-11	ELECT	22uF 20% 50V	IC902	8-759-231-54	IC TA7806S	
C723	1-164-094-11	CERAMIC	0.0068uF 10% 25V (F419R:G/F519R:G)	IC903	8-759-234-64	IC TA7805S	
C910	1-124-563-11	ELECT	2200uF 20% 25V	< TRANSISTOR >			
C913	1-136-159-00	FILM	0.033uF 5% 50V	Q711	8-729-620-05	TRANSISTOR 2SC2603-EF	
C914	1-164-073-11	CERAMIC	100PF 10% 50V (F419R:G/F519R:G)	Q713	8-729-900-63	TRANSISTOR DTA124ES	
< CONNECTOR >							
* CNP1	1-564-321-00	PIN, CONNECTOR 2P		Q900	8-729-620-05	TRANSISTOR 2SC2603-EF	
CNP700	1-566-213-11	PIN, CONNECTOR 4P (CONTROL S OUT)		< RESISTOR >			
CNP800	1-691-162-11	PIN, CONNECTOR 5P		R723	1-249-393 11	CARBON 10 5% 1/4W	
< DIODE >							
D701	8-719-933-39	DIODE HZ56C1L		R724	1-249-417 11	CARBON 1K 5% 1/4W	
D702	8-719-200-82	DIODE 11ES2		R725	1-249-429-11	CARBON 10K 5% 1/4W	
D727	8-719-987-63	DIODE 1N4148M		R735	1-249-419-11	CARBON 1.5K 5% 1/4W	
D904	8-719-200-82	DIODE 11ES2		R736	1-249-433-11	CARBON 22K 5% 1/4W	
< RELAY >							
< TRANSFORMER >							
< TRANSFORMER >							
< TRANSFORMER >							
$\Delta$ T2	1-449-071 11	TRANSFORMER, POWER		R737	1-249-423-11	CARBON 3.3K 5% 1/4W	
< RELAY >							
$\Delta$ RY900	1-515-516-00	RELAY (F419R)		R908	1-247-733-11	CARBON 33 5% 1/2W (F419R)	
$\Delta$ RY900	1-515-617-11	RELAY (F519R)		H908	1-247-727-11	CARBON 10 5% 1/2W (F519R)	

HEADPHONE	INPUT
-----------	-------

Ref. No.	Part No.	Description	Remark		
*	1-644-626-11	HEADPHONE BOARD *****			
		< CAPACITOR >			
C805	1-136-161-00	FILM	0.047uF	5%	50V
C807	1-136-161-00	FILM	0.047uF	5%	50V
		< CONNECTOR >			
* CNP900	1-560-943-00	PIN, CONNECTOR 9P			
		< DIODE >			
D800	8-719-987-63	DIODE 1N4148M			
		< JACK >			
J800	1-573-203-11	JACK, LARGE TYPE (HEADPHONES)			
		< RESISTOR >			
R527	1-247-752-11	CARBON	1K	5%	1/2W
R528	1-247-752-11	CARBON	1K	5%	1/2W
R627	1-247-752-11	CARBON	1K	5%	1/2W
R628	1-247-752-11	CARBON	1K	5%	1/2W
R805	1-247-757-11	CARBON	2.7K	5%	1/2W(F419R)
R805	1-247-251-00	CARBON	3K	5%	1/2W(F519R)
R807	1-247-757-11	CARBON	2.7K	5%	1/2W(F419R)
R807	1-247-758-11	CARBON	3.3K	5%	1/2W(F519R)
R808	1-247-757-11	CARBON	2.7K	5%	1/2W(F419R)
R808	1-247-758-11	CARBON	3.3K	5%	1/2W(F519R)
R809	1-247-757-11	CARBON	2.7K	5%	1/2W(F419R)
R809	1-247-758-11	CARBON	3.3K	5%	1/2W(F519R)
R810	1-247-757-11	CARBON	2.7K	5%	1/2W(F419R)
R810	1-247-758-11	CARBON	3.3K	5%	1/2W(F519R)
R811	1-247-757-11	CARBON	2.7K	5%	1/2W(F419R)
R811	1-247-758-11	CARBON	3.3K	5%	1/2W(F519R)
R812	1-247-757-11	CARBON	2.7K	5%	1/2W(F419R)
R812	1-247-758-11	CARBON	3.3K	5%	1/2W(F519R)
R813	1-247-757-11	CARBON	2.7K	5%	1/2W(F419R)
R813	1-247-758-11	CARBON	3.3K	5%	1/2W(F519R)
R814	1-247-757-11	CARBON	2.7K	5%	1/2W(F419R)
R814	1-247-758-11	CARBON	3.3K	5%	1/2W(F519R)
		< RELAY >			
RY802	1-515-793-11	RELAY			
		< SWITCH >			
S900	1-692-147-11	SWITCH, ROTARY SLIDE (SPEAKERS)			

Ref. No.	Part No.	Description	Remark		
*	A-4347-650-A	INPUT BOARD, COMPLETE (F419R:AEP/F519R:AEP)			
*	A-4347-651-A	INPUT BOARD, COMPLETE (F419R:G/F519R:G) *****			
		< CAPACITOR >			
C151	1-162-286-31	CERAMIC	220PF	10%	50V(F419R:G/F519R:G)
C152	1-162-286-31	CERAMIC	220PF	10%	50V(F419R:G/F519R:G)
C153	1-162-286-31	CERAMIC	220PF	10%	50V(F419R:G/F519R:G)
C154	1-162-286-31	CERAMIC	220PF	10%	50V(F419R:G/F519R:G)
C155	1-162-286-31	CERAMIC	220PF	10%	50V(F419R:G/F519R:G)
C156	1-162-286-31	CERAMIC	220PF	10%	50V(F419R:G/F519R:G)
C157	1-162-286-31	CERAMIC	220PF	10%	50V(F419R:G/F519R:G)
C159	1-162-286-31	CERAMIC	220PF	10%	50V(F419R:G/F519R:G)
C251	1-162-286-31	CERAMIC	220PF	10%	50V(F419R:G/F519R:G)
C252	1-162-286-31	CERAMIC	220PF	10%	50V(F419R:G/F519R:G)
C253	1-162-286-31	CERAMIC	220PF	10%	50V(F419R:G/F519R:G)
C254	1-162-286-31	CERAMIC	220PF	10%	50V(F419R:G/F519R:G)
C255	1-162-286-31	CERAMIC	220PF	10%	50V(F419R:G/F519R:G)
C256	1-162-286-31	CERAMIC	220PF	10%	50V(F419R:G/F519R:G)
C257	1-162-286-31	CERAMIC	220PF	10%	50V(F419R:G/F519R:G)
C353	1-164-058-11	CERAMIC	33PF	5%	50V(F419R:G/F519R:G)
C711	1-124-471-00	ELECT	1000uF	20%	6.3V
C712	1-124-907-11	ELECT	10uF	20%	50V
C713	1-124-907-11	ELECT	10uF	20%	50V
C714	1-124-907-11	ELECT	10uF	20%	50V
C715	1-124-907-11	ELECT	10uF	20%	50V
		< CONNECTOR >			
* CNJ101	1-691-180-11	CONNECTOR (BOARD TO BOARD) 10P			
* CNP702	1-564-505-11	PLUG, CONNECTOR 2P			
		< IC >			
IC703	8-759-962-08	IC BA6208			
IC704	8-759-962-08	IC BA6208			
		< JACK >			
J101	1-566-883-71	JACK, PIN 6P (AUX/CD/TUNER)			
J102	1-566-882-51	JACK, PIN 4P (TAPE2)			
J103	1-566-882-51	JACK, PIN 4P (DAT/TAPE1) (F419R:AEP/F519R:AEP)			
J103	1-566-882-61	JACK, PIN 4P (DAT/TAPE1) (F419R:G/F519R:G)			

**INPUT      JOINT (A)      JOINT (C)      JOINT (D)      KEY**

Ref. No.	Part No.	Description	Remark	Ref. No.	Part No.	Description	Remark
< RESISTOR >							
R115	1-247-713-11	CARBON	1K 5% 1/4W	*	1-644-630-11	JOINT (D) BOARD *****	
R116	1-247-713-11	CARBON	1K 5% 1/4W			< CONNECTOR >	
R117	1-259-500-11	CARBON	1M 5% 1/6W	* CNJ800	1-691-175-11	CONNECTOR (BOARD TO BOARD) 5P	
R118	1-259-500-11	CARBON	1M 5% 1/6W		CNP801	1-691-162-11	PIN, CONNECTOR 5P
R119	1-259-500-11	CARBON	1M 5% 1/6W	*****			
R120	1-259-500-11	CARBON	1M 5% 1/6W	*	A-4347-648-A	KEY BOARD, COMPLETE (F419R:AEP/F519R:AEP)	
R121	1-259-500-11	CARBON	1M 5% 1/6W	*	A-4347-649-A	KEY BOARD, COMPLETE (F419R:G/F519R:G) *****	
R215	1-247-713-11	CARBON	1K 5% 1/4W			< CAPACITOR >	
R216	1-247-713-11	CARBON	1K 5% 1/4W	C705	1-164-085-11	CERAMIC	0.001uF 10% 50V
R217	1-259-500-11	CARBON	1M 5% 1/6W	C706	1-126-176-11	ELECT	220uF 20% 10V
R218	1-259-500-11	CARBON	1M 5% 1/6W	C707	1-136-161-00	FILM	0.047uF 5% 50V
R219	1-259-500-11	CARBON	1M 5% 1/6W	C724	1-124-927-11	ELECT	4.7uF 20% 100V
R220	1-259-500-11	CARBON	1M 5% 1/6W	C750	1-126-233-11	ELECT	22uF 20% 50V
R221	1-259-500-11	CARBON	1M 5% 1/6W	C751	1-126-233-11	ELECT	22uF 20% 50V
R350	1-247-700-11	CARBON	100 5% 1/4W (F419R:G/F519R:G)	C752	1-164-085-11	CERAMIC	0.001uF 10% 50V
R450	1-247-700-11	CARBON	100 5% 1/4W (F419R:G/F519R:G)			< CONNECTOR >	
< VARIABLE RESISTOR >				* CNJ300	1-565-321-11	SOCKET, CONNECTOR (PC BOARD) 8P	
RV300	1-241-913-11	RES, VAR. CARBON	120K/120K (VOLUME)	* CNJ701	1-568-865-11	SOCKET, CONNECTOR 23P	
< SWITCH >				CNJ900	1-562-088-00	SOCKET, CONNECTOR 9P	
S102	1-571-115-11	SWITCH, SLIDE	(REC OUT SELECTOR)	* CNJ903	1-561-652-00	SOCKET, CONNECTOR 12P	
S103	1-692-142-11	SWITCH, ROTARY	(WITH MOTOR) (INPUT SELECTOR)			< DIODE >	
*****				D703	8-719-987-63	DIODE	1N4148M
*	1-644-628-11	JOINT (A) BOARD *****		D704	8-719-987-63	DIODE	1N4148M
		< CONNECTOR >		D708	8-719-987-63	DIODE	1N4148M
* CNJ501	1-691-180-11	CONNECTOR (BOARD TO BOARD)	10P	D709	8-719-987-63	DIODE	1N4148M
	CNP101	1-691-167-11	PIN, CONNECTOR 10P	D710	8-719-987-63	DIODE	1N4148M
*****				D711	8-719-987-63	DIODE	1N4148M
*	1-644-620-11	JOINT (C) BOARD *****		D712	8-719-987-63	DIODE	1N4148M
		< CONNECTOR >		D713	8-719-987-63	DIODE	1N4148M
* CNP901	1-580-854-11	PIN, CONNECTOR (PC BOARD)	6P	D714	8-719-987-63	DIODE	1N4148M
* CNP902	1-580-854-11	PIN, CONNECTOR (PC BOARD)	6P	D715	8-719-987-63	DIODE	1N4148M
* CNP903	1-560-443-11	PIN, CONNECTOR	12P	D716	8-719-987-63	DIODE	1N4148M
*****				D717	8-719-313-69	DIODE	SEL3210S-CD
				D718	8-719-313-72	LED	SEL3810A-CD
				D720	8-719-018-46	LED	SEL3510C-CD
				D721	8-719-018-46	LED	SEL3510C-CD
				D722	8-719-018-46	LED	SEL3510C-CD
				D723	8-719-018-46	LED	SEL3510C-CD
				D724	8-719-018-46	LED	SEL3510C-CD
				D725	8-719-018-46	LED	SEL3510C-CD



**KEY**   **LED**   **MAIN**

Ref. No.	Part No.	Description	Remark
< IC >			
IC702	8-749-920-83	IC GP1U52XB	
IC705	8-759-635-31	IC M50253P	
< TRANSISTOR >			
Q700	8-729-900-63	TRANSISTOR DTA124ES	
Q701	8-729-900-63	TRANSISTOR DTA124ES	
Q702	8-729-900-36	TRANSISTOR DTC124ES	
Q703	8-729-900-63	TRANSISTOR DTA124ES	
Q704	8-729-620-05	TRANSISTOR 2SC2603-EF	
Q705	8-729-620-05	TRANSISTOR 2SC2603-EF	
Q706	8-729-900-63	TRANSISTOR DTA124ES	
Q707	8-729-900-63	TRANSISTOR DTA124ES	
Q709	8-729-900-63	TRANSISTOR DTA124ES	
< RESISTOR >			
R717	1-247-710-11	CARBON 560 5% 1/4W	
R718	1-249-433-11	CARBON 22K 5% 1/4W	
R719	1-247-702-11	CARBON 150 5% 1/4W	
R720	1-247-703-11	CARBON 180 5% 1/4W	
R721	1-247-703-11	CARBON 180 5% 1/4W	
R726	1-249-429-11	CARBON 10K 5% 1/4W	
R727	1-249-429-11	CARBON 10K 5% 1/4W	
R728	1-249-417-11	CARBON 1K 5% 1/4W	
R729	1-249-417-11	CARBON 1K 5% 1/4W	
R730	1-249-429-11	CARBON 10K 5% 1/4W	
R731	1-249-433-11	CARBON 22K 5% 1/4W	
R732	1-249-438-11	CARBON 56K 5% 1/4W	
R733	1-249-433-11	CARBON 22K 5% 1/4W	
R734	1-249-433-11	CARBON 22K 5% 1/4W	
R738	1-249-433-11	CARBON 22K 5% 1/4W	
R739	1-249-433-11	CARBON 22K 5% 1/4W	
R740	1-249-433-11	CARBON 22K 5% 1/4W	
R741	1-249-433-11	CARBON 22K 5% 1/4W	
R742	1-249-433-11	CARBON 22K 5% 1/4W	
R743	1-249-433-11	CARBON 22K 5% 1/4W	
R744	1-249-433-11	CARBON 22K 5% 1/4W	
R745	1-249-433-11	CARBON 22K 5% 1/4W	
R753	1-249-429-11	CARBON 10K 5% 1/4W	
R760	1-249-405-11	CARBON 100 5% 1/4W	
R761	1-249-405-11	CARBON 100 5% 1/4W	
< SWITCH >			
S700	1-554-303-21	SWITCH, TACTILE (PHONO)	
S701	1-554-303-21	SWITCH, TACTILE (TUNER)	
S702	1-554-303-21	SWITCH, TACTILE (CD)	
S703	1-554-303-21	SWITCH, TACTILE (AUX)	
S704	1-554-303-21	SWITCH, TACTILE (DAT/TAPE 1)	

Ref. No.	Part No.	Description	Remark
S705	1-554-303-21	SWITCH, TACTILE (TAPE 2)	
S706	1-554-303-21	SWITCH, TACTILE (POWER)	
S707	1-554-303-21	SWITCH, TACTILE (SOURCE DIRECT)	
*****			
*	1-644-622-11	LED BOARD	*****
< CONNECTOR >			
*	CNP703 1-564-505-11	PLUG, CONNECTOR 2P	
< DIODE >			
D719	8-719-028-38	DIODE SEL2215R-CD-TP	
*****			
*	A-4347-636-A	MAIN BOARD, COMPLETE (F519R:AEP1)	
*	A-4347-637-A	MAIN BOARD, COMPLETE (F519R:AEP2)	
*	A-4347-638-A	MAIN BOARD, COMPLETE (F519R:G)	
*	A-4347-678-A	MAIN BOARD, COMPLETE (F419R:AEP1)	
*	A-4347-679-A	MAIN BOARD, COMPLETE (F419R:AEP2)	
*	A-4347-680-A	MAIN BOARD, COMPLETE (F419R:G)	*****
< CAPACITOR >			
C100	1-164-077-11	CERAMIC 220PF 10% 50V	
C101	1-123-369-00	ELECT 4.7uF 20% 50V	
C102	1-161-377-00	CERAMIC 0.0047uF 30% 16V	
C103	1-136-162-00	FILM 0.056uF 5% 50V	
C104	1-137-471-11	FILM 0.016uF 5% 50V	
C105	1-126-059-11	ELECT 10uF 20% 50V	
C106	1-124-910-11	ELECT 47uF 20% 50V(F419R)	
C106	1-126-541-11	ELECT 330uF 20% 16V(F519R)	
C107	1-126-059-11	ELECT 10uF 20% 50V	
C150	1-162-282-31	CERAMIC 100PF 10% 50V	(F419R:G/F519R:G)
C158	1-164-073-11	CERAMIC 100PF 10% 50V	
C200	1-164-077-11	CERAMIC 220PF 10% 50V	
C201	1-123-369-00	ELECT 4.7uF 20% 50V	
C202	1-161-377-00	CERAMIC 0.0047uF 30% 16V	
C203	1-136-162-00	FILM 0.056uF 5% 50V	
C204	1-137-471-11	FILM 0.016uF 5% 50V	
C205	1-126-059-11	ELECT 10uF 20% 50V	
C206	1-124-910-11	ELECT 47uF 20% 50V(F419R)	
C206	1-126-541-11	ELECT 330uF 20% 16V(F519R)	



## MAIN

Ref. No.	Part No.	Description	Remark	Ref. No.	Part No.	Description	Remark
D507	8-719-987-63	DIODE	1N4148M	Q201	8-729-354-52	TRANSISTOR	2SC2545-E
D508	8-719-815-85	DIODE	1S1585	Q500	8-729-620-17	TRANSISTOR	2SC2259-FG
D509	8-719-815-85	DIODE	1S1585	Q501	8-729-119-76	TRANSISTOR	2SA1175 HFE
D600	8-719-987-63	DIODE	1N4148M	Q502	8-729-140-84	TRANSISTOR	2SC1841 PAFAEA
D601	8-719-933-39	DIODE	HZS6C1L	Q503	8-729-224-62	TRANSISTOR	2SK246-GR
D602	8-719-987-63	DIODE	1N4148M	Q504	8-729-140-82	TRANSISTOR	2SA988-PAFAEA
D603	8-719-987-63	DIODE	1N4148M	Q505	8-729-803-76	TRANSISTOR	2SA1371-E
D604	8-719-987-63	DIODE	1N4148M	Q506	8-729-142-01	TRANSISTOR	2SC1941-LK
D605	8-719-987-63	DIODE	1N4148M	Q507	8-729-209-15	TRANSISTOR	2SD2012
D606	8-719-987-63	DIODE	1N4148M	Q508	8-729-141-46	TRANSISTOR	2SC4431-LK
D607	8-719-987-63	DIODE	1N4148M	Q509	8-729-141-37	TRANSISTOR	2SA1684-LK
D608	8-719-815-85	DIODE	1S1585	Q510	8-729-011-14	TRANSISTOR	2SC3855M-OPY (F419R)
D609	8-719-815-85	DIODE	1S1585	Q510	8-729-010-97	TRANSISTOR	2SC3856M-OPY (F519R)
D700	8-719-200-82	DIODE	11ES2	Q511	8-729-011-13	TRANSISTOR	2SA1491M-OPY (F419R)
D705	8-719-987-63	DIODE	1N4148M	Q511	8-729-010-98	TRANSISTOR	2SA1492M-OPY (F519R)
D706	8-719-987-63	DIODE	1N4148M	Q512	8-729-140-82	TRANSISTOR	2SA988-PAFAEA
D707	8-719-987-63	DIODE	1N4148M	Q513	8-729-141-26	TRANSISTOR	2SC3622A-LK
D728	8-719-010-15	DIODE	U2-3, OBS	Q600	8-729-620-17	TRANSISTOR	2SC2259-FG
D729	8-719-987-63	DIODE	1N4148M	Q601	8-729-119-76	TRANSISTOR	2SA1175-HFE
D900	8-719-302-38	DIODE	RBV-602-01	Q602	8-729-140-84	TRANSISTOR	2SC1841-PAFAEA
D901	8-719-200-02	DIODE	10E2	Q603	8-729-224-62	TRANSISTOR	2SK246-GR
D902	8-719-200-02	DIODE	10E2	Q604	8-729-140-82	TRANSISTOR	2SA988-PAFAEA
D908	8-719-933-88	DIODE	HZS16-2L	Q605	8-729-803-76	TRANSISTOR	2SA1371-E
D909	8-719-933-88	DIODE	HZS16-2L	Q606	8-729-142-01	TRANSISTOR	2SC1941-LK
		< IC >		Q607	8-729-209-15	TRANSISTOR	2SD2012
IC100	8-759-745-61	IC	NJM4560D D	Q608	8-729-141-46	TRANSISTOR	2SC4431-LK
IC300	8-759-634-50	IC	M5218AL	Q609	8-729-141-37	TRANSISTOR	2SA1684-LK
IC700	8-759-082-11	IC	M50720-358SP	Q610	8-729-011-14	TRANSISTOR	2SC3855M-OPY (F419R)
IC800	8-759-111-68	IC	uPC1237HA	Q610	8-729-010-97	TRANSISTOR	2SC3856M-OPY (F519R)
		< JACK >		Q611	8-729-011-13	TRANSISTOR	2SA1491M-OPY (F419R)
J100	1-580-054-21	JACK, PIN 2P		Q611	8-729-010-98	TRANSISTOR	2SA1492M-OPY (F519R)
		< COIL >		Q612	8-729-140-82	TRANSISTOR	2SA988-PAFAEA
L100	1-410-979-11	INDUCTOR	220uH (F419R:G)	Q613	8-729-141-26	TRANSISTOR	2SC3622A-LK
L100	1-424-397-11	COIL, CHOKE	200uH (F519R:G)	Q708	8-729-900-63	TRANSISTOR	DTA124ES
L101	1-424-397-11	COIL, CHOKE	200uH (F519R:G)	Q710	8-729-900-36	TRANSISTOR	DTC124ES
L200	1-410-979-11	INDUCTOR	220uH (F419R:G)	Q712	8-729-900-63	TRANSISTOR	DTA124ES
L200	1-424-397-11	COIL, CHOKE	200uH (F519R:G)	Q714	8-729-620-05	TRANSISTOR	2SC2603-EF
L201	1-424-397-11	COIL, CHOKE	200uH (F519R:G)	Q715	8-729-900-63	TRANSISTOR	DTA124ES
		< TRANSISTOR >		Q901	8-729-140-84	TRANSISTOR	2SC1841-PAFAEA
Q100	8-729-354-52	TRANSISTOR	2SC2545-E	Q902	8-729-140-82	TRANSISTOR	2SA988-PAFAEA
Q101	8-729-354-52	TRANSISTOR	2SC2545-E			< RESISTOR >	
Q200	8-729-354-52	TRANSISTOR	2SC2545-E	R100	1-247-700-11	CARBON	100 5% 1/4W(F519R)
				R101	1-249-469-11	CARBON	100K 5% 1/4W
				R102	1-247-706-11	CARBON	330 5% 1/4W
				R103	1-249-469-11	CARBON	100K 5% 1/4W
				R104	1-247-725-11	CARBON	10K 5% 1/4W

MAIN

Ref. No.	Part No.	Description		Remark	Ref. No.	Part No.	Description		Remark
R105	1-247-710-11	CARBON	560	5% 1/4W	R504	1-247-704-11	CARBON	220	5% 1/4W
R106	1-247-702-11	CARBON	150	5% 1/4W					(F419R:AEP1,G/F519R:AEP1,G)
R107	1-247-710-11	CARBON	560	5% 1/4W	△R504	1-212-889-00	FUSIBLE	220	5% 1/4W F
R108	1-247-716-11	CARBON	1.8K	5% 1/4W					(F419R:AEP2/F519R:AEP2)
R109	1-260-661-11	CARBON	6.8	5% 1/4W(F519R)	R505	1-247-704-11	CARBON	220	5% 1/4W
R110	1-247-700-11	CARBON	100	5% 1/4W					(F419R:AEP1,G/F519R:AEP1,G)
R111	1-246-545-00	CARBON	1.0M	5% 1/4W	△R505	1-212-889-00	FUSIBLE	220	5% 1/4W F
R112	1-249-844-11	CARBON	56K	5% 1/2W					(F419R:AEP2/F519R:AEP2)
R113	1-249-689-11	CARBON	4.7K	5% 1/2W	R506	1-247-704-11	CARBON	220	5% 1/4W
R114	1-247-713-11	CARBON	1K	5% 1/4W	R507	1-249-490-11	CARBON	27K	5% 1/2W
R150	1-259-436-11	CARBON	2.2K	5% 1/6W(F419R:G)	R508	1-247-721-11	CARBON	4.7K	5% 1/4W
R150	1-259-428-11	CARBON	1K	5% 1/6W(F519R:G)	R509	1-249-516-11	CARBON	33	5% 1/4W
R151	1-259-428-11	CARBON	1K	5% 1/6W(F519R:G)					(F419R:AEP1,G/F519R:AEP1,G)
R200	1-247-700-11	CARBON	100	5% 1/4W(F519R)	△R509	1-212-869-00	FUSIBLE	33	5% 1/4W F
R201	1-249-469-11	CARBON	100K	5% 1/4W					(F419R:AEP2/F519R:AEP2)
R202	1-247-706-11	CARBON	330	5% 1/4W	R510	1-249-524-11	CARBON	68	5% 1/4W
R203	1-249-469-11	CARBON	100K	5% 1/4W					(F419R:AEP1,G/F519R:AEP1,G)
R204	1-247-725-11	CARBON	10K	5% 1/4W	△R510	1-212-877-11	FUSIBLE	68	5% 1/4W F
R205	1-247-710-11	CARBON	560	5% 1/4W					(F419R:AEP2/F519R:AEP2)
R206	1-247-702-11	CARBON	150	5% 1/4W	R511	1-247-713-11	CARBON	1K	5% 1/4W
R207	1-247-710-11	CARBON	560	5% 1/4W	R512	1-249-561-11	CARBON	2.4K	5% 1/4W
R209	1-260-661-11	CARBON	6.8	5% 1/4W(F519R)	R513	1-247-710-11	CARBON	560	5% 1/4W
R210	1-247-700-11	CARBON	100	5% 1/4W	△R514	1-212-857-00	FUSIBLE	10	5% 1/4W F
R211	1-246-545-00	CARBON	1.0M	5% 1/4W	△R515	1-212-857-00	FUSIBLE	10	5% 1/4W F
R212	1-249-844-11	CARBON	56K	5% 1/2W	R516	1-249-469-11	CARBON	100K	5% 1/4W
R213	1-249-689-11	CARBON	4.7K	5% 1/2W	△R517	1-212-994-00	FUSIBLE	330	5% 1/2W F
R214	1-247-713-11	CARBON	1K	5% 1/4W	△R518	1-212-849-00	FUSIBLE	4.7	5% 1/4W F
R250	1-259-436-11	CARBON	2.2K	5% 1/6W(F419R:G)	△R519	1-212-849-00	FUSIBLE	4.7	5% 1/4W F
R250	1-259-428-11	CARBON	1K	5% 1/6W(F519R:G)	R520	1-217-611-00	METAL PLATE	0.1	
R251	1-259-428-11	CARBON	1K	5% 1/6W(F519R:G)	R521	1-217-611-00	METAL PLATE	0.1	
R300	1-249-469-11	CARBON	100K	5% 1/4W	R522	1-249-421-11	CARBON	2.2K	5% 1/4W
R301	1-247-713-11	CARBON	1K	5% 1/4W	R523	1-249-431-11	CARBON	15K	5% 1/4W
R302	1-247-713-11	CARBON	1K	5% 1/4W	R525	1-247-887-00	CARBON	220K	5% 1/4W
R303	1-247-719-11	CARBON	3.3K	5% 1/4W	R529	1-247-846-11	CARBON	4.3K	5% 1/4W
R304	1-247-704-11	CARBON	220	5% 1/4W	R530	1-247-713-11	CARBON	1K	5% 1/4W
R311	1-246-545-00	CARBON	1.0M	5% 1/4W(F519R)	R531	1-247-887-00	CARBON	220K	5% 1/4W
R400	1-249-469-11	CARBON	100K	5% 1/4W	R600	1-247-713-11	CARBON	1K	5% 1/4W
R401	1-247-713-11	CARBON	1K	5% 1/4W	R601	1-249-469-11	CARBON	100K	5% 1/4W
R402	1-247-713-11	CARBON	1K	5% 1/4W	R602	1-247-704-11	CARBON	220	5% 1/4W
R403	1-247-719-11	CARBON	3.3K	5% 1/4W	R603	1-247-717-11	CARBON	2.2K	5% 1/4W
R404	1-247-704-11	CARBON	220	5% 1/4W	R604	1-247-704-11	CARBON	220	5% 1/4W
R411	1-246-545-00	CARBON	1.0M	5% 1/4W(F519R)					(F419R:AEP1,G/F519R:AEP1,G)
R500	1-247-713-11	CARBON	1K	5% 1/4W	△R604	1-212-889-00	FUSIBLE	220	5% 1/4W F
R501	1-249-469-11	CARBON	100K	5% 1/4W					(F419R:AEP2/F519R:AEP2)
R502	1-247-704-11	CARBON	220	5% 1/4W	R605	1-247-704-11	CARBON	220	5% 1/4W
R503	1-247-717-11	CARBON	2.2K	5% 1/4W					(F419R:AEP1,G/F519R:AEP1,G)
					△R605	1-212-889-00	FUSIBLE	220	5% 1/4W F
									(F419R:AEP2/F519R:AEP2)

Note: The components identified by mark △ or dotted line with mark △ are critical for safety. Replace only with part number specified.

## MAIN

Ref. No.	Part No.	Description	Remark	Ref. No.	Part No.	Description	Remark
R606	1-247-704-11	CARBON	220 5% 1/4W	R748	1-249-433-11	CARBON	22K 5% 1/4W
R607	1-249-490-11	CARBON	27K 5% 1/2W	R749	1-247-903-00	CARBON	1M 5% 1/4W
R608	1-247-721-11	CARBON	4.7K 5% 1/4W	R750	1-249-429-11	CARBON	10K 5% 1/4W
R609	1-249-516-11	CARBON	33 5% 1/4W	R751	1-249-430-11	CARBON	12K 5% 1/4W
△R609	1-212-869-00	FUSIBLE	(F419R:AEP1, G/F519R:AEP1, G) 33 5% 1/4W F	R752	1-249-417-11	CARBON	1K 5% 1/4W
R610	1-249-524-11	CARBON	(F419R:AEP2/F519R:AEP2) 68 5% 1/4W	R753	1-249-433-11	CARBON	22K 5% 1/4W
△R610	1-212-877-11	FUSIBLE	(F419R:AEP1, G/F519R:AEP1, G) 68 5% 1/4W F	R760	1-249-405-11	CARBON	10G 5% 1/4W
R611	1-247-713-11	CARBON	(F419R:AEP2/F519R:AEP2) 1K 5% 1/4W	R761	1-249-433-11	CARBON	22K 5% 1/4W
R612	1-249-561-11	CARBON	2.4K 5% 1/4W	R800	1-249-429-11	CARBON	10K 5% 1/4W
R613	1-247-710-11	CARBON	560 5% 1/4W	R801	1-247-887-00	CARBON	220K 5% 1/4W
△R614	1-212-857-00	FUSIBLE	10 5% 1/4W F	R802	1-247-881-00	CARBON	120K 5% 1/4W
△R615	1-212-857-00	FUSIBLE	10 5% 1/4W F	R803	1-249-432-11	CARBON	18K 5% 1/4W
R616	1-249-469-11	CARBON	100K 5% 1/4W	R900	1-247-754-11	CARBON	1.5K 5% 1/2W(F419R)
△R617	1-212-994-00	FUSIBLE	330 5% 1/2W F	R900	1-247-755-11	CARBON	1.8K 5% 1/2W(F519R)
△R618	1-212-849-00	FUSIBLE	4.7 5% 1/4W F	R901	1-247-754-11	CARBON	1.5K 5% 1/2W(F419R)
△R619	1-212-849-00	FUSIBLE	4.7 5% 1/4W F	R901	1-247-755-11	CARBON	1.8K 5% 1/2W(F519R)
R620	1-217-611-00	METAL PLATE	0.1	R902	1-247-754-11	CARBON	1.5K 5% 1/2W(F419R)
R621	1-217-611-00	METAL PLATE	0.1	R902	1-247-755-11	CARBON	1.8K 5% 1/2W(F519R)
R622	1-249-421-11	CARBON	2.2K 5% 1/4W	R903	1-247-754-11	CARBON	1.5K 5% 1/2W(F419R)
R623	1-249-431-11	CARBON	15K 5% 1/4W	R903	1-247-755-11	CARBON	1.8K 5% 1/2W(F519R)
R625	1-247-887-00	CARBON	220K 5% 1/4W	R904	1-247-754-11	CARBON	1.5K 5% 1/2W(F419R)
R629	1-247-846-11	CARBON	4.3K 5% 1/4W	R904	1-247-755-11	CARBON	1.8K 5% 1/2W(F519R)
R630	1-247-713-11	CARBON	1K 5% 1/4W	R905	1-247-754-11	CARBON	1.5K 5% 1/2W(F419R)
R631	1-247-887-00	CARBON	220K 5% 1/4W	R905	1-247-755-11	CARBON	1.8K 5% 1/2W(F519R)
R700	1-249-433-11	CARBON	22K 5% 1/4W	R906	1-247-754-11	CARBON	1.5K 5% 1/2W(F419R)
R701	1-249-433-11	CARBON	22K 5% 1/4W	R906	1-247-755-11	CARBON	1.8K 5% 1/2W(F519R)
R702	1-249-433-11	CARBON	22K 5% 1/4W	R907	1-247-754-11	CARBON	1.5K 5% 1/2W(F419R)
R703	1-249-427-11	CARBON	6.8K 5% 1/4W	R907	1-247-755-11	CARBON	1.8K 5% 1/2W(F519R)
R704	1-249-427-11	CARBON	6.8K 5% 1/4W	R909	1-247-722-11	CARBON	5.6K 5% 1/4W
R705	1-249-433-11	CARBON	22K 5% 1/4W	R910	1-247-722-11	CARBON	5.6K 5% 1/4W
R706	1-249-433-11	CARBON	22K 5% 1/4W			< VARIABLE RESISTOR >	
R707	1-249-433-11	CARBON	22K 5% 1/4W	RV500	1-237-455-11	RES, ADJ, CARBON 500 (DC BIAS L-CH)	
R708	1-249-433-11	CARBON	22K 5% 1/4W	RV600	1-237-455-11	RES, ADJ, CARBON 500 (DC BIAS R-CH)	
R709	1-249-433-11	CARBON	22K 5% 1/4W			< RELAY >	
R710	1-249-433-11	CARBON	22K 5% 1/4W	RY300	1-515-793-11	RELAY	
R711	1-249-441-11	CARBON	100K 5% 1/4W			< SWITCH >	
R713	1-249-433-11	CARBON	22K 5% 1/4W	S100	1-571-111-11	SWITCH, PUSH (1 KEY) (CARTRIDGE) (F519R)	
R714	1-249-433-11	CARBON	22K 5% 1/4W	S300	1-692-146-11	SWITCH, PUSH (1 KEY) (SUBSONIC) (F519R)	
R715	1-249-433-11	CARBON	22K 5% 1/4W			< THERMISTOR >	
R716	1-249-433-11	CARBON	22K 5% 1/4W	△TH900	1-806-882-11	THERMISTOR, POSITIVE 2.2	
R722	1-247-757-11	CARBON	2.7K 5% 1/2W			(F419R:AEP2/F519R:AEP2)	
R746	1-249-433-11	CARBON	22K 5% 1/4W	△TH901	1-806-882-11	THERMISTOR, POSITIVE 2.2	
R747	1-249-433-11	CARBON	22K 5% 1/4W			(F419R:AEP2/F519R:AEP2)	

Note: The components identified by mark △ or dotted line with mark △ are critical for safety. Replace only with part number specified.

**MAIN**   **OUTLET**   **PRI**   **SEC**   **SP**   **TONE**

Ref.No.	Part No.	Description	Remark
		< VIBRATOR >	
X700	1-567-254-11	VIBRATOR, CERAMIC	
*****			
*	1-644-623-11	OUTLET BOARD *****	
		< OUTLET >	
△CNJ901	1-526-794-11	OUTLET, AC	
*****			
*	1-644-621-11	PRI BOARD *****	
		< CAPACITOR >	
C508	1-136-163-00	FILM            0.068uF   5%   50V	
C509	1-136-163-00	FILM            0.068uF   5%   50V	
C608	1-136-163-00	FILM            0.068uF   5%   50V	
C609	1-136-163-00	FILM            0.068uF   5%   50V	
		< CONNECTOR >	
* CNJ801	1-691-175-11	CONNECTOR (BOARD TO BOARD) 5P	
CNJ901	1-561-115-00	SOCKET, CONNECTOR 6P	
CNJ902	1-561-115-00	SOCKET, CONNECTOR 6P	
* CNP903	1-564-241-00	PIN, CONNECTOR (B4P-VH) 4P	
		< DIODE >	
D801	8-719-987-63	DIODE   1N4148M	
D802	8-719-987-63	DIODE   1N4148M	
		< COIL >	
L500	1-428-133-11	COIL, AIR-CORE	
L600	1-428-133-11	COIL, AIR-CORE	
		< RESISTOR >	
R524	1-247-727-11	CARBON            10   5%   1/2W	
R526	1-247-727-11	CARBON            10   5%   1/2W	
R624	1-247-727-11	CARBON            10   5%   1/2W	
R626	1-247-727-11	CARBON            10   5%   1/2W	
		< RELAY >	
RY800	1-515-676-11	RELAY	
RY801	1-515-676-11	RELAY	
*****			

Ref.No.	Part No.	Description	Remark
*	1-644-627-11	SEC BOARD *****	
*	1-690-880-31	LEAD (WITH CONNECTOR) (F419R:G/F519R:G)	
		< CAPACITOR >	
C950	1-164-094-11	CERAMIC   0.0068uF   10%   25V (F419R:G/F519R:G)	
C951	1-130-789-00	FILM                    1uF            5%   100V	
		< RESISTOR >	
△R950	1-212-966-00	FUSIBLE            22   5%   1/2W F	
*****			
*	1-644-619-11	SP BOARD *****	
		< CAPACITOR >	
C551	1-136-161-00	FILM   0.047uF   5%   50V(F419R:G/F519R:G)	
C552	1-136-161-00	FILM   0.047uF   5%   50V(F419R:G/F519R:G)	
C553	1-136-153-00	FILM   0.01uF   5%   50V(F419R:G/F519R:G)	
C651	1-136-161-00	FILM   0.047uF   5%   50V(F419R:G/F519R:G)	
C652	1-136-161-00	FILM   0.047uF   5%   50V(F419R:G/F519R:G)	
C653	1-136-153-00	FILM   0.01uF   5%   50V(F419R:G/F519R:G)	
		< RESISTOR >	
R551	1-249-482-11	CARBON   4.7   5%   1/2W (F419R:G/F519R:G)	
R552	1-249-482-11	CARBON   4.7   5%   1/2W (F419R:G/F519R:G)	
R651	1-249-482-11	CARBON   4.7   5%   1/2W (F419R:G/F519R:G)	
R652	1-249-482-11	CARBON   4.7   5%   1/2W (F419R:G/F519R:G)	
		< TERMINAL >	
TM900	1-537-227-11	TERMINAL BOARD (SP) (F419R:AEP2/F519R:AEP2)	
TM900	1-537-228-11	TERMINAL BOARD (SP) (F419R:AEP1,G/F519R:AEP1,G)	
*****			
*	1-644-625-11	TONE BOARD *****	
		< CAPACITOR >	
C304	1-136-155-00	FILM                    0.015uF   5%   50V	
C305	1-136-161-00	FILM                    0.047uF   5%   50V	
C306	1-136-169-00	FILM                    0.22uF   5%   50V	
C307	1-136-175-00	FILM                    0.68uF   5%   50V	

Note: The components identified by mark **△** or dotted line with mark **△** are critical for safety. Replace only with part number specified.

**STONE**

Ref. No.	Part No.	Description	Remark
C404	1-136-155-00	FILM 0.015uF 5%	50V
C405	1-136-161-00	FILM 0.047uF 5%	50V
C406	1-136-169-00	FILM 0.22uF 5%	50V
C407	1-136-175-00	FILM 0.68uF 5%	50V
< CONNECTOR >			
CNP300	1-695-240-11	PIN, CONNECTOR 8P	
< RESISTOR >			
R305	1-259-421-11	CARBON 510 5%	1/4W
R306	1-246-545-00	CARBON 1.0M 5%	1/4W
R307	1-246-545-00	CARBON 1.0M 5%	1/4W
R308	1-247-703-11	CARBON 180 5%	1/4W
R309	1-247-718-11	CARBON 2.7K 5%	1/4W
R310	1-249-551-11	CARBON 910 5%	1/4W
R405	1-259-421-11	CARBON 510 5%	1/4W
R406	1-246-545-00	CARBON 1.0M 5%	1/4W
R407	1-246-545-00	CARBON 1.0M 5%	1/4W
R408	1-247-703-11	CARBON 180 5%	1/4W
R409	1-247-718-11	CARBON 2.7K 5%	1/4W
R410	1-249-551-11	CARBON 910 5%	1/4W
< VARIABLE RESISTOR >			
RV301	1-241-974-11	RES. VAR, CARBON 10K (TREBLE)	
RV302	1-241-972-11	RES. VAR, CARBON 10K (BASS)	
RV303	1-241-973-11	RES. VAR, CARBON 100K/100K (BALANCE)	

\*\*\*\*\*

MISCELLANEOUS  
\*\*\*\*\*

20	1-590-499-31	WIRE, FLAT TYPE (23 CORE)
21	1-692-148-11	SWITCH, ROTARY SLIDE
△109	1-575-651-11	CORD, POWER
△T1	1-450-928-11	TRANSFORMER, POWER (F519R)
△T1	1-450-929-11	TRANSFORMER, POWER (F419R:AEP1, Germany)
△T1	1-450-930-12	TRANSFORMER, POWER (F419R:AEP2)

\*\*\*\*\*

Ref. No.	Part No.	Description	Remark
ACCESSORIES & PACKING MATERIALS *****			
	1-693-131-11	REMOTE COMMANDER (RM-S311)	
	2-181-754-01	COVER, BATTERY	
	3-755-074-11	MANUAL, INSTRUCTION (ENGLISH/FRENCH/SPANISH/PORTUGUESE) (F419R:AEP/F519R:AEP)	
	3-755-074-41	MANUAL, INSTRUCTION (GERMAN/DUTCH/SWEDISH/ITALIAN)	
*	4-951-287-01	INDIVIDUAL CARTON (F419R)	
*	4-951-288-01	INDIVIDUAL CARTON (F519R)	
*	4-952-575-01	CUSHION	
*****			
***** HARDWARE LIST *****			
#1	7-682-547-04	SCREW +BVTT 3X6 (S)	
#2	7-685-651-79	SCREW +BVTP 3X20 TYPE2 N-S	
#3	7-685-648-79	SCREW +BVTP 3X12 TYPE2	
#4	7-685-646-79	SCREW +BVTP 3X8 TYPE2 N-S	
#5	7-621-849-00	SCREW (BV/RING)	
#6	7-682-560-04	SCREW +BVTT 4X6 (S)	

Note: The components identified by mark  $\Delta$  or dotted line with mark  $\Delta$  are critical for safety. Replace only with part number specified.