

TA-F190



SERVICE MANUAL

Germany Model

This set is almost the same as model TA-F170 previously produced.

Therefore, see the TA-F170/F240 service manual for the information which is contained in this service manual.

 : Modified point

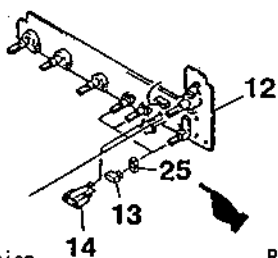
Page	TA-F170	TA-F190																																								
1	<p>Power consumption</p> <p>Model Germany</p> <table border="1"> <thead> <tr> <th colspan="2"></th> <th>TA-F170</th> </tr> </thead> <tbody> <tr> <td rowspan="2">DIN 1 kHz</td> <td>4 ohms</td> <td>50 W + 50 W</td> </tr> <tr> <td>8 ohms</td> <td>35 W + 35 W</td> </tr> </tbody> </table>			TA-F170	DIN 1 kHz	4 ohms	50 W + 50 W	8 ohms	35 W + 35 W	<p>Power consumption</p> <table border="1"> <thead> <tr> <th colspan="2"></th> <th></th> </tr> </thead> <tbody> <tr> <td rowspan="2">DIN 1 kHz</td> <td>4 ohms</td> <td>55 W + 55 W </td> </tr> <tr> <td>8 ohms</td> <td>35 W + 35 W</td> </tr> </tbody> </table>				DIN 1 kHz	4 ohms	55 W + 55 W 	8 ohms	35 W + 35 W																								
		TA-F170																																								
DIN 1 kHz	4 ohms	50 W + 50 W																																								
	8 ohms	35 W + 35 W																																								
DIN 1 kHz	4 ohms	55 W + 55 W 																																								
	8 ohms	35 W + 35 W																																								
14	<table border="1"> <thead> <tr> <th>Ref. No.</th> <th>Part No.</th> <th>Description</th> <th>Remark</th> </tr> </thead> <tbody> <tr> <td>2</td> <td>4-945-182-01</td> <td>PANEL, FRONT (F170)</td> <td></td> </tr> <tr> <td>13</td> <td>4-945-176-01</td> <td>BUTTON (18X11)</td> <td></td> </tr> </tbody> </table>	Ref. No.	Part No.	Description	Remark	2	4-945-182-01	PANEL, FRONT (F170)		13	4-945-176-01	BUTTON (18X11)		 <table border="1"> <thead> <tr> <th>Ref. No.</th> <th>Part No.</th> <th>Description</th> <th>Remark</th> </tr> </thead> <tbody> <tr> <td>2</td> <td>4-945-182-32</td> <td>PANEL, FRONT</td> <td></td> </tr> <tr> <td>13</td> <td>4-947-011-01</td> <td>BUTTON (F)</td> <td></td> </tr> <tr> <td>25</td> <td>4-864-307-00</td> <td>RING</td> <td></td> </tr> </tbody> </table>	Ref. No.	Part No.	Description	Remark	2	4-945-182-32	PANEL, FRONT		13	4-947-011-01	BUTTON (F)		25	4-864-307-00	RING													
Ref. No.	Part No.	Description	Remark																																							
2	4-945-182-01	PANEL, FRONT (F170)																																								
13	4-945-176-01	BUTTON (18X11)																																								
Ref. No.	Part No.	Description	Remark																																							
2	4-945-182-32	PANEL, FRONT																																								
13	4-947-011-01	BUTTON (F)																																								
25	4-864-307-00	RING																																								
15	<table border="1"> <tbody> <tr> <td>57</td> <td>4-945-480-01</td> <td>SHEET, INSULATING</td> <td></td> </tr> <tr> <td>59</td> <td>* 2-379-614-01</td> <td>HOOK</td> <td></td> </tr> <tr> <td>60</td> <td>3-706-165-00</td> <td>SCREW</td> <td></td> </tr> <tr> <td>61</td> <td>* 4-944-986-21</td> <td>PANEL, BACK (F170:GERMANY)</td> <td></td> </tr> </tbody> </table>	57	4-945-480-01	SHEET, INSULATING		59	* 2-379-614-01	HOOK		60	3-706-165-00	SCREW		61	* 4-944-986-21	PANEL, BACK (F170:GERMANY)		<table border="1"> <tbody> <tr> <td>57</td> <td>not supplide</td> <td></td> <td></td> </tr> <tr> <td>59</td> <td>* 4-949-235-01</td> <td>HOOK</td> <td></td> </tr> <tr> <td>60</td> <td>4-947-010-01</td> <td>SCREW, FEEDER FIXED</td> <td></td> </tr> <tr> <td>61</td> <td>* 4-944-986-61</td> <td>PANEL, BACK</td> <td></td> </tr> </tbody> </table>	57	not supplide			59	* 4-949-235-01	HOOK		60	4-947-010-01	SCREW, FEEDER FIXED		61	* 4-944-986-61	PANEL, BACK									
57	4-945-480-01	SHEET, INSULATING																																								
59	* 2-379-614-01	HOOK																																								
60	3-706-165-00	SCREW																																								
61	* 4-944-986-21	PANEL, BACK (F170:GERMANY)																																								
57	not supplide																																									
59	* 4-949-235-01	HOOK																																								
60	4-947-010-01	SCREW, FEEDER FIXED																																								
61	* 4-944-986-61	PANEL, BACK																																								
20	<table border="1"> <tbody> <tr> <td></td> <td>3-753-389-11</td> <td>MANUAL, INSTRUCTION</td> <td></td> </tr> <tr> <td></td> <td>* 4-944-050-01</td> <td>INDIVIDUAL CARTON</td> <td></td> </tr> <tr> <td></td> <td>* 4-945-810-01</td> <td>CUSHION (LEFT) (F240)</td> <td></td> </tr> <tr> <td></td> <td>* 4-945-811-01</td> <td>CUSHION (RIGHT) (F240)</td> <td></td> </tr> <tr> <td># 5</td> <td>7-682-549-04</td> <td>SCREW +BVTT 3X10 (S)</td> <td></td> </tr> </tbody> </table>		3-753-389-11	MANUAL, INSTRUCTION			* 4-944-050-01	INDIVIDUAL CARTON			* 4-945-810-01	CUSHION (LEFT) (F240)			* 4-945-811-01	CUSHION (RIGHT) (F240)		# 5	7-682-549-04	SCREW +BVTT 3X10 (S)		<table border="1"> <tbody> <tr> <td></td> <td>3-755-007-41</td> <td>MANUAL, INSTRUCTION (GERMAN)</td> <td></td> </tr> <tr> <td></td> <td>* 4-951-286-01</td> <td>INDIVIDUAL CARTON</td> <td></td> </tr> <tr> <td></td> <td>* 4-945-810-01</td> <td>CUSHION (LEFT)</td> <td></td> </tr> <tr> <td></td> <td>* 4-945-811-01</td> <td>CUSHION (RIGHT)</td> <td></td> </tr> <tr> <td># 5</td> <td>7-685-647-79</td> <td>SCREW +BVTP 3X10 TYPE2 IT-3</td> <td></td> </tr> </tbody> </table>		3-755-007-41	MANUAL, INSTRUCTION (GERMAN)			* 4-951-286-01	INDIVIDUAL CARTON			* 4-945-810-01	CUSHION (LEFT)			* 4-945-811-01	CUSHION (RIGHT)		# 5	7-685-647-79	SCREW +BVTP 3X10 TYPE2 IT-3	
	3-753-389-11	MANUAL, INSTRUCTION																																								
	* 4-944-050-01	INDIVIDUAL CARTON																																								
	* 4-945-810-01	CUSHION (LEFT) (F240)																																								
	* 4-945-811-01	CUSHION (RIGHT) (F240)																																								
# 5	7-682-549-04	SCREW +BVTT 3X10 (S)																																								
	3-755-007-41	MANUAL, INSTRUCTION (GERMAN)																																								
	* 4-951-286-01	INDIVIDUAL CARTON																																								
	* 4-945-810-01	CUSHION (LEFT)																																								
	* 4-945-811-01	CUSHION (RIGHT)																																								
# 5	7-685-647-79	SCREW +BVTP 3X10 TYPE2 IT-3																																								

INTEGRATED STEREO AMPLIFIER
SONY



SECTION 3 ELECTRICAL ADJUSTMENT

Note:

- Adjustment should be performed 10 minutes after the POWER switch on (POWER ON).

Bias Current Adjustment

Setting:

VOLUME control: minimum

Adjustment Location:

[MAIN BOARD] — Component Side —

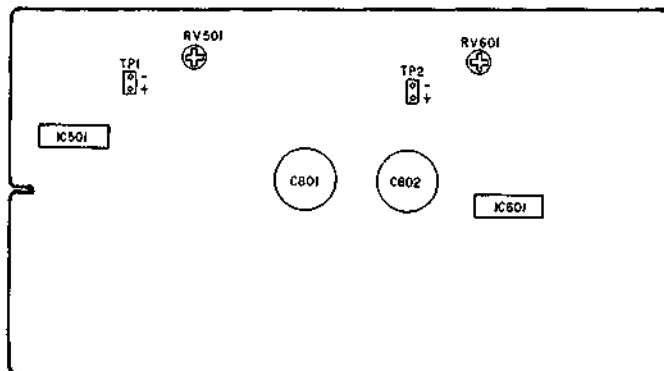
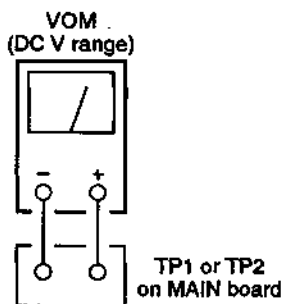

Procedure:

Adjust RV501 (L-CH) and RV601 (R-CH) so as to obtain 4 mV at TP1 and TP2 respectively.

TA-F170/F240

SERVICE MANUAL

AEP Model
E Model
Germany Model
TA-F170
UK Model
TA-F170/F240

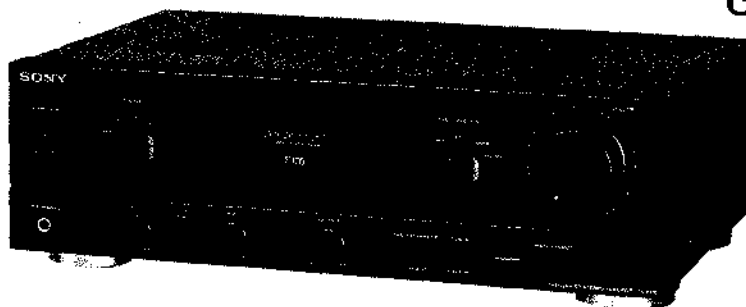

Photo: TA-F170

SPECIFICATIONS

Amplifier

Continuous RMS power output (both channels driven simultaneously)

Models for Scandinavian countries, Spain and Portugal

		TA-F170
DIN 1 kHz	6 ohms	50 W + 50 W
	8 ohms	40 W + 40 W
20 Hz - 20 kHz	8 ohms	30 W + 30 W THD 0.05 %

Model Germany

		TA-F170
DIN 1 kHz	4 ohms	50 W + 50 W
	8 ohms	35 W + 35 W
20 Hz - 20 kHz	4 ohms	—
20 Hz - 20 kHz	8 ohms	30 W + 30 W THD 0.05 %

Model UK

		TA-F170	TA-F240
DIN 1 kHz	4 ohms	50 W + 50 W	80 W + 80 W
	8 ohms	40 W + 40 W	70 W + 70 W
20 Hz - 20 kHz	8 ohms	30 W + 30 W THD 0.05 %	60 W + 60 W 0.05 %

AEP, E Model

		TA-F170
DIN 1 kHz	4 ohms	50 W + 50 W
	8 ohms	40 W + 40 W
20 Hz - 20 kHz	4 ohms	—
20 Hz - 20 kHz	8 ohms	30 W + 30 W THD 0.05 %

Tone controls

	Response	Turnover frequency
BASS	± 6 dB	500 Hz
TREBLE	± 6 dB	3 kHz

Input

Input jack	Jack type	Sensitivity	Impedance	S/N (weighting network, input level)
PHONO	MM	2.0 mV	50 kilohms	76 dB (A, 5 mV)
	MC	170 μV	100 ohms	75 dB (A, 0.5 mV)
TUNER, CD, AUX, TAPE/DAT	Phono	150 mV	50 kilohms	96 dB (150 mV)

— Continued on next page —

INTEGRATED STEREO AMPLIFIER
SONY®



Output

Output jack	Jack type	Voltage/impedance
REC OUT	Phono	Voltage 150 mV Impedance 1 kohms
SPEAKERS	—	Model for Scandinavian countries, Spain and Portugal Accepts speakers of 6 – 16 ohms. Models for other countries Accepts speakers of 4 – 16 ohms
HEAD-PHONES	Stereo phone	Accepts low and high impedance headphones.

Loudness (Attenuation 30 dB)
+6 dB (100 Hz) / +3 dB (10 kHz)
Subsonic filter 6 dB/octave, attenuation below 15Hz
Intermodulation (IM) distortion (60 Hz: 7 kHz=4: 1)
Less than 0.05% at rated output
Frequency response **PHONE:** RIAA equalization curve ± 0.5 dB
TUNER, CD, AUX, TAPE1/DAT:
7 Hz – 100 kHz ± 3 dB
Residual noise Less than 190 μ V (network A)
Damping factor 40 (8 ohms, 1 kHz)

Power requirements AEP, Germany models:
220 – 230 V AC, 50 Hz
UK model: 240 V AC, 50 Hz
E model: 120 V,
220 V or 240 V AC adjustable, 50/60 Hz

MODEL IDENTIFICATION

— Specification Labels —

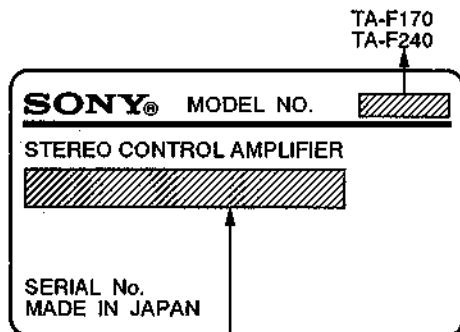

AEP, Germany model: AC: 220 – 230 V ~ 50/60Hz 90 W
TA-F170 UK model: AC: 240 V ~ 50/60 Hz 250 W
TA-F240 UK model: AC: 240 V ~ 50/60 Hz 380 W
E model: AC: 120/220/240 V ~ 50/60 Hz
90 W

Power consumption

Models for	F170	F240
UK	250 W	380 W
Germany	95 W	—
AEP, E	90 W	—

Dimensions Approx. 430 × 135 × 312 mm (w/h/d)
(17 × 5³/₈ × 12³/₈ inches)

Weight TA-F170: Approx. 7.6 kg (16 lb 12 oz)
TA-F240: Approx. 8 kg (17 lb 10 oz)

* For all the countries except U.K. and Canada, the above values are measured at 230 V AC.

Design and specifications subject to change without notice.

Note

This appliance conforms with EEC directive 87/308/EEC regarding interference suppression.

TABLE OF CONTENTS

<u>Section</u>	<u>Title</u>	<u>Page</u>
Specifications	1
Model Identification	2
Precautions	3
1. GENERAL	4
Connections	4
Parts Identification	4
2. DISASSEMBLY	5
2-1. Disassembly Of Front Panel	5
3. ELECTRICAL ADJUSTMENTS	5
4. DIAGRAMS	6
4-1. Block Diagram	6
4-2. Printed Wiring Boards	8
4-3. Schematic Diagram	11
5. EXPLODED VIEWS	14
6. ELECTRICAL PARTS LIST	16

SAFETY-RELATED COMPONENT WARNING!!

COMPONENTS IDENTIFIED BY MARK Δ OR DOTTED LINE WITH MARK Δ ON THE SCHEMATIC DIAGRAMS AND IN THE PARTS LIST ARE CRITICAL TO SAFE OPERATION. REPLACE THESE COMPONENTS WITH SONY PARTS WHOSE PART NUMBERS APPEAR AS SHOWN IN THIS MANUAL OR IN SUPPLEMENTS PUBLISHED BY SONY.

ATTENTION AU COMPOSANT AYANT RAPPORT À LA SÉCURITÉ

LES COMPOSANTS IDENTIFIÉS PAR UNE MARQUE Δ SUR LES DIAGRAMMES SCHÉMATIQUES ET LA LISTE DES PIÈCES SONT CRITIQUES POUR LA SÉCURITÉ DE FONCTIONNEMENT. NE REMPLACER CES COMPOSANTS QUE PAR DES PIÈCES SONY DONT LES NUMÉROS SONT DONNÉS DANS CE MANUEL OU DANS LES SUPPLÉMENTS PUBLIÉS PAR SONY.

Precautions

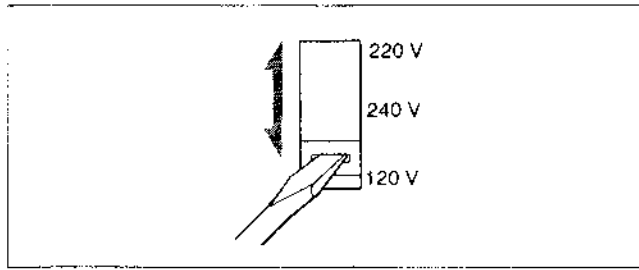

On safety

- Before operating the unit, check that the operating voltage of your unit is identical with the voltage of your local power supply.

Where purchased	Operating voltage
Canada	120 V AC
United Kingdom	240 V AC
Continental European countries	220 - 230 V AC
Other countries	120 V, 220 V or 240 V AC adjustable The voltage selector is located on the rear panel. If the selector must be reset, disconnect the AC power cord and set the selector to the proper voltage of your local power supply.

- Unplug the unit from the wall outlet if it is not to be used for an extended period of time. To disconnect the cord, pull it out by grasping the plug. Never pull the cord itself.
- Should any solid object or liquid fall into the unit, unplug the unit and have it checked by qualified personnel before operating it any further.
- Do not block the ventilation holes on top of the unit. The ventilation holes must be unobstructed for proper operation of the unit and to prolong the life of its components.
- AC power cord must be changed only at the qualified service shop.

On cleaning the cabinet

Clean the cabinet, panels and controls with a soft cloth lightly moistened with a mild detergent solution. Do not use any type of abrasive pad, scouring powder or solvent such as alcohol or benzene.

On repacking

Do not throw away the carton and the packing material. This makes an ideal container when transporting the unit. When shipping the unit, repack it as it was packed at the factory.

If you have any question or problem concerning your unit, please consult your nearest Sony dealer.

SECTION 1 GENERAL

This section is extracted from TA-F170/
F240/F270/F470 instruction manual.

Parts Identification/Identification des parties Identificación de partes/Identificação dos comandos

Refer to the pages indicated in ● for details.
Pour les détails, se reporter aux pages indiquées dans les cercles noirs.
Para los detalles, véase las páginas indicadas en ●.
Consulte as páginas indicadas nas ● para mais pormenores.

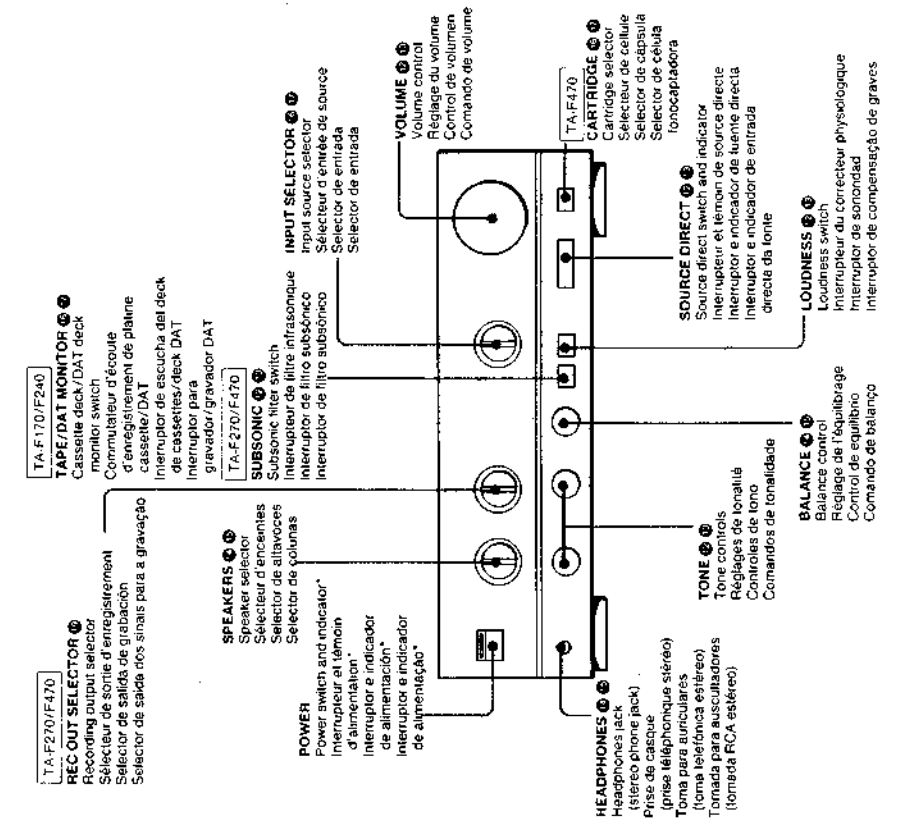

Connexions

Remarques sur les connexions

- Le cordon d'alimentation doit être branché en dernier lieu, après s'être assuré que l'appareil est bien hors tension.
- Les fiches des cordons et les prises sont codées par couleur. Les fiches et prises rouges sont destinées au canal droit (R) et les blanches, au canal gauche (L).
- Insérer les connecteurs des câbles à fond dans les prises. En effet, une connexion relâchée peut provoquer un ronflement ou du bruit.

Connections

Notes on Connection

- Connect the AC power cord last. Make sure power is off.
- Cord plugs and jacks are color coded. Red plugs and jacks are for right channel (R) and white ones for left channel (L).
- Fully insert cable connectors into jacks. Loose connections may cause hum or noise.

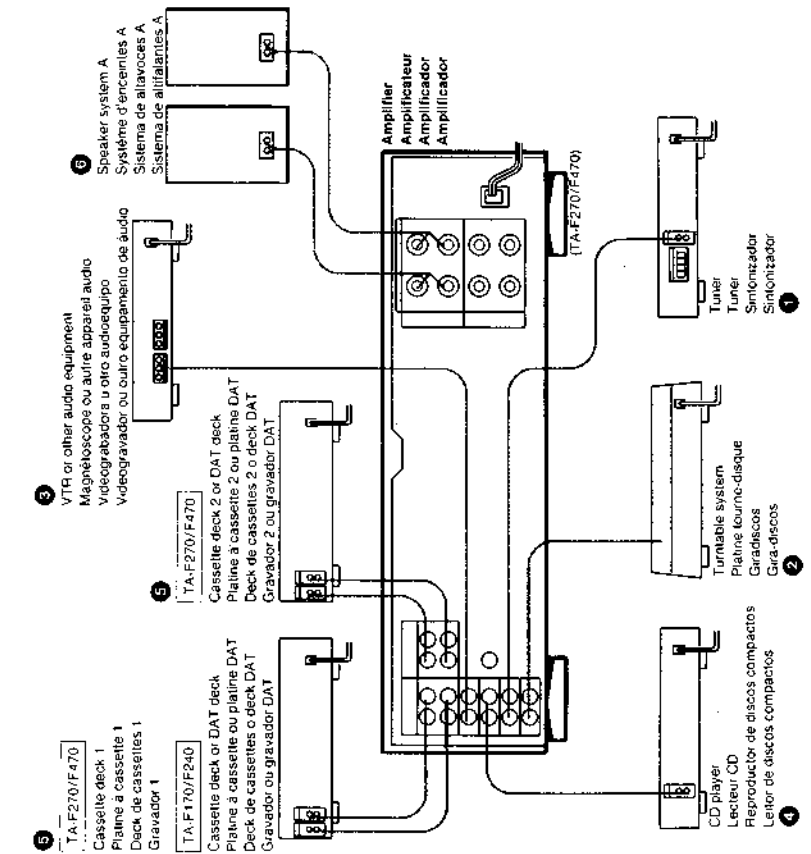

SECTION 2 DISASSEMBLY

2-1. DISASSEMBLY OF FRONT PANEL

Note: Follow the disassembly procedure in the numerical order given.

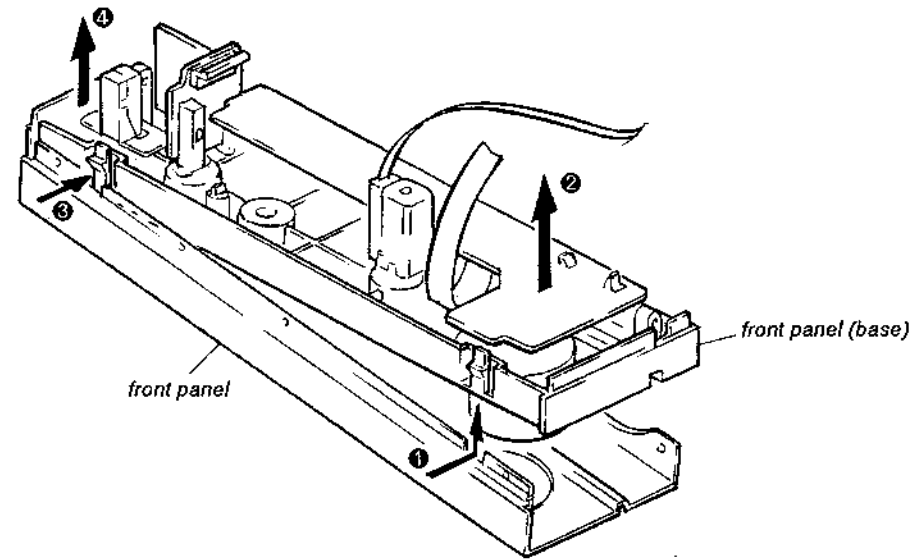

SECTION 3 ELECTRICAL ADJUSTMENT

NOTE:

- Adjustment should be performed 10 minutes after the POWER switch is on (POWER ON).

Bias Current Adjustment

Setting:
VOLUME control: minimum

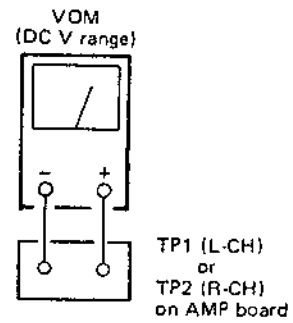

Adjustment Location:

[AMP BOARD] -- Component Side --

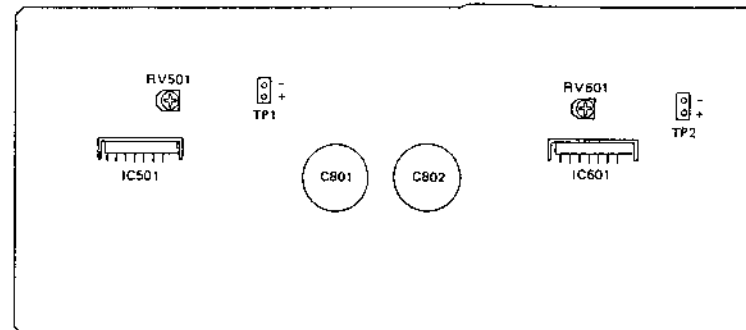

Procedure:

Adjust RV501 (L-CH) and RV601 (R-CH) so as to obtain 4 mV (TA-F120) or 2 mV (TA-F220) at TP1 (L-CH) and TP2 (R-CH) respectively.

4-1. BLOCK DIAGRAM

SECTION 4 DIAGRAM

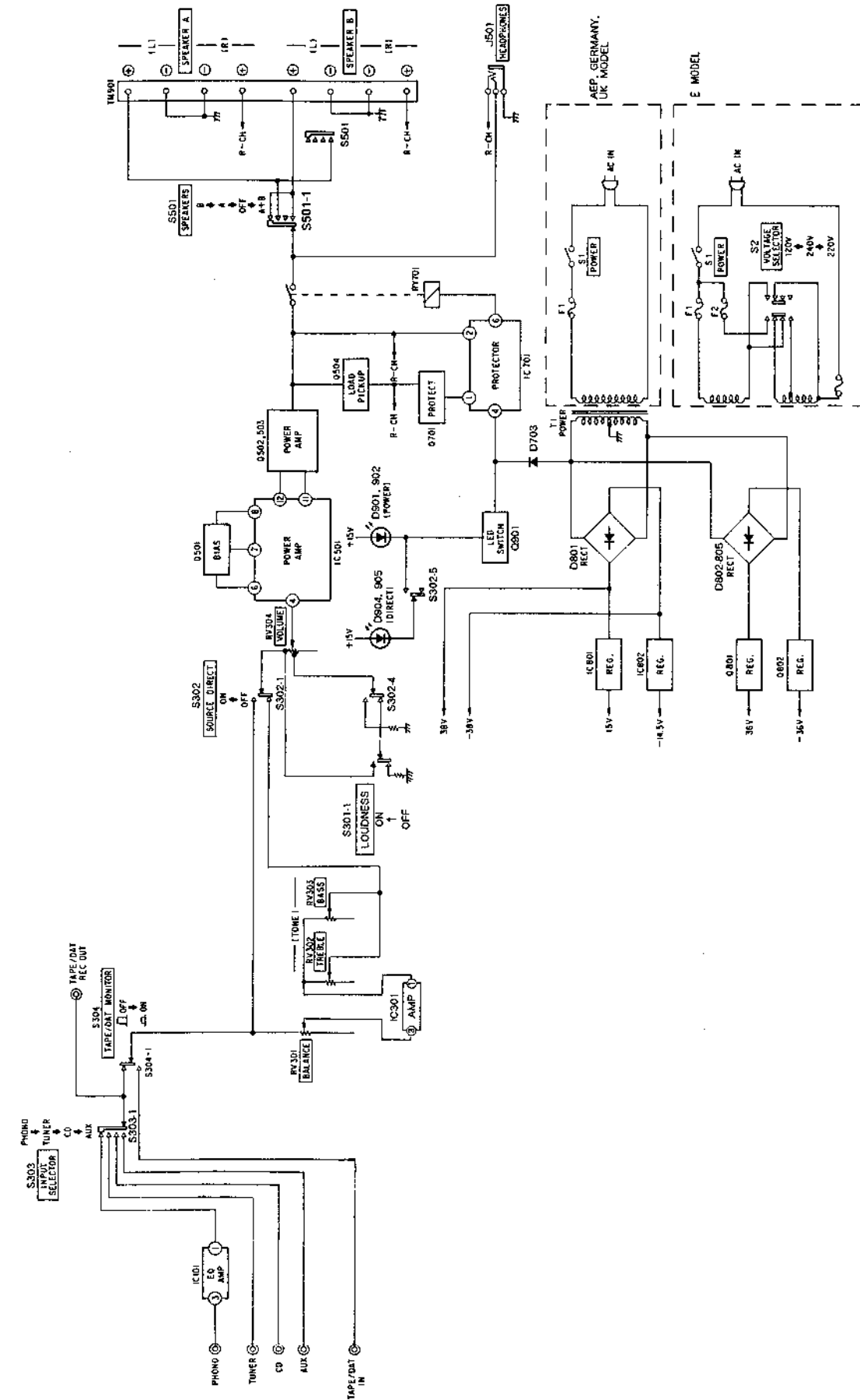

4-2. PRINTED WIRING BOARDS

• Circuit Boards Location

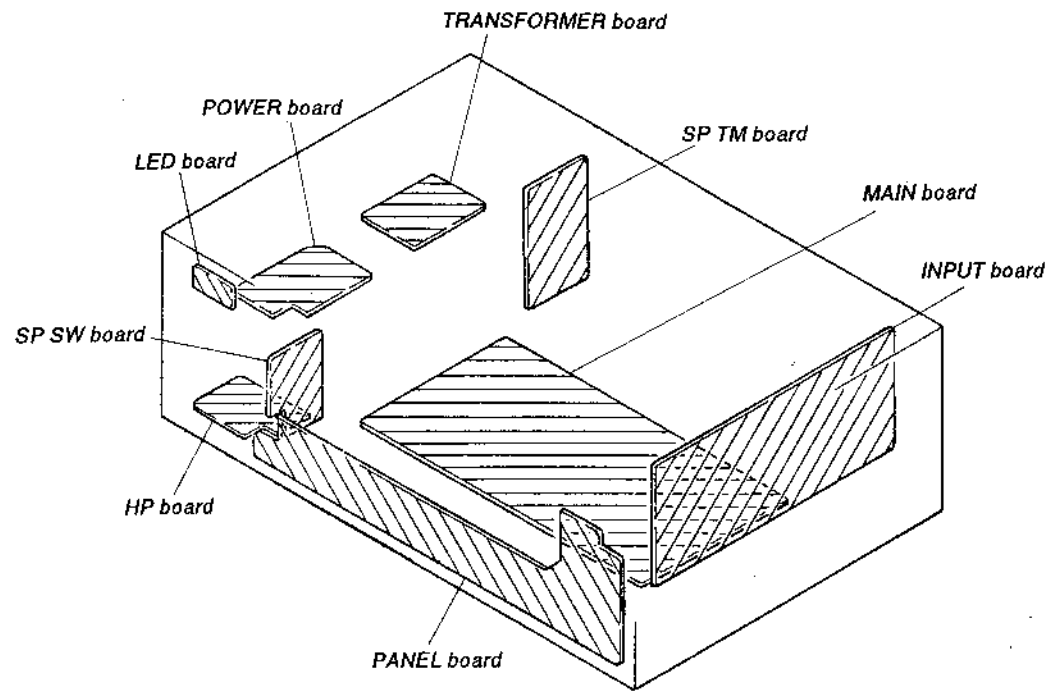

• Semiconductor Location

Ref. No.	Location
D501	B-15
D502	B-15
D601	B-11
D602	B-11
D701	D-14
D702	E-14
D703	E-12
D801	E-10
D802	E-13
D803	E-13
D804	F-13
D805	F-13
D901	H-15
D902	H-15
D904	K-8
D905	K-8
IC101	F-4
IC301	J-14
IC501	C-15
IC601	D-9
IC701	D-14
IC801	D-7
IC802	D-8
Q501	A-13
Q502	A-14
Q503	A-12
Q504	B-15
Q601	A-9
Q602	A-10
Q603	A-8
Q604	B-11
Q701	D-14
Q801	E-15
Q802	F-15
Q901	E-15

• Semiconductor Lead Layouts

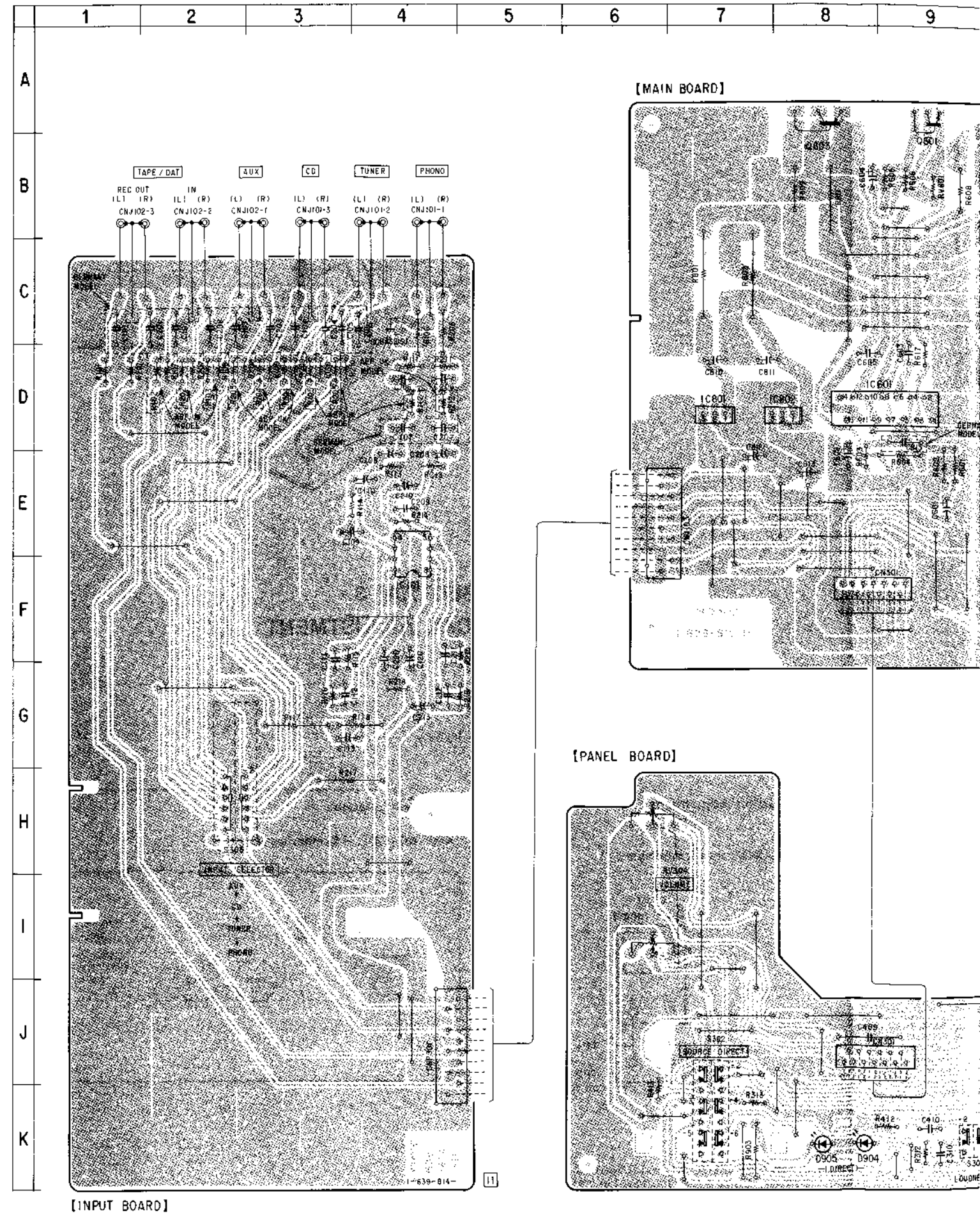
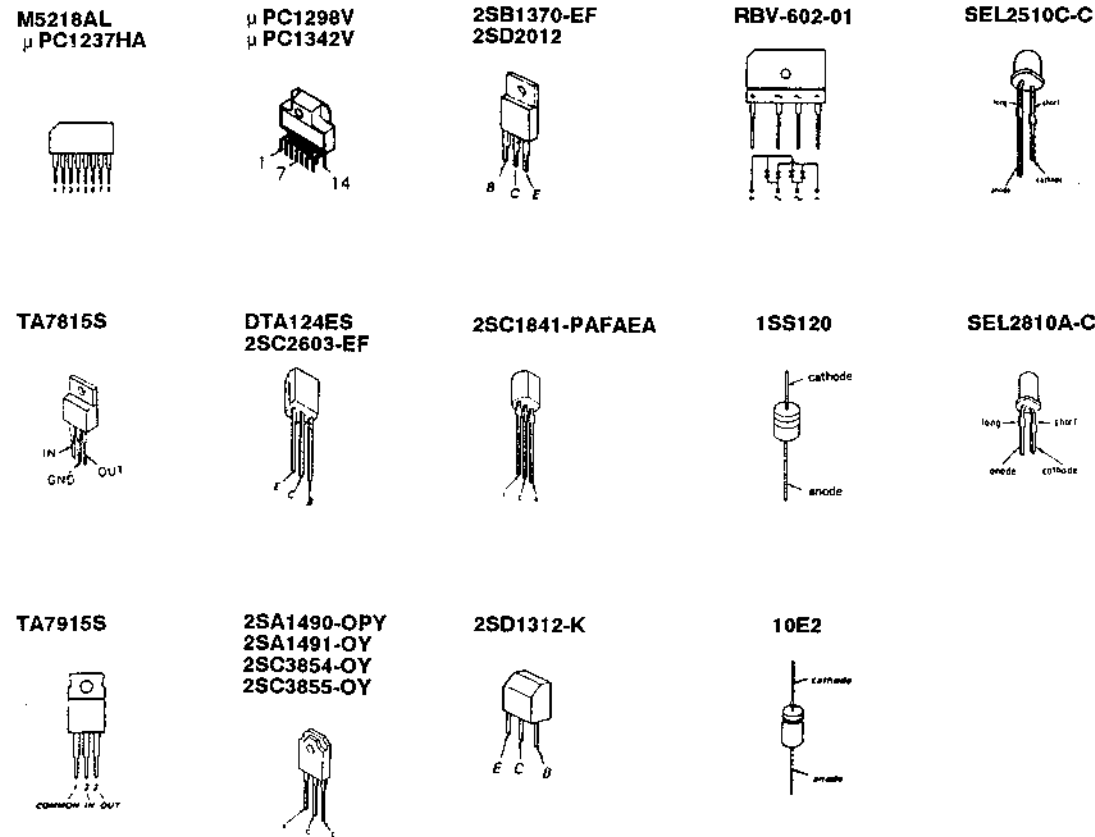

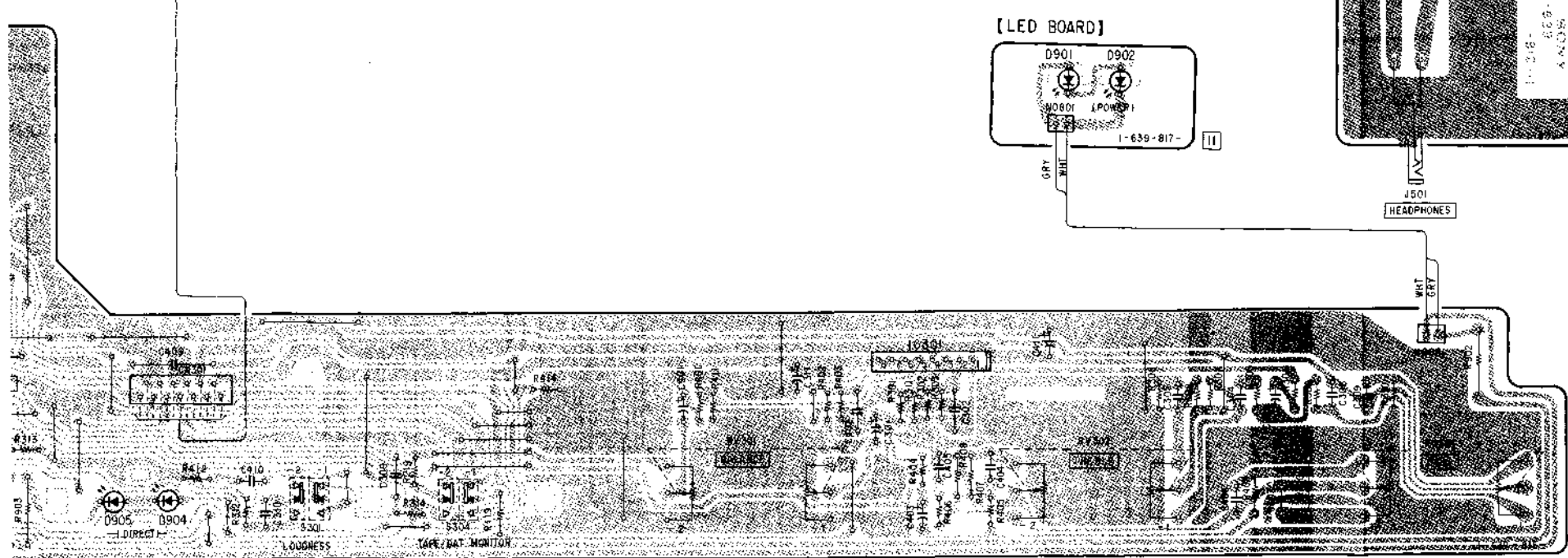
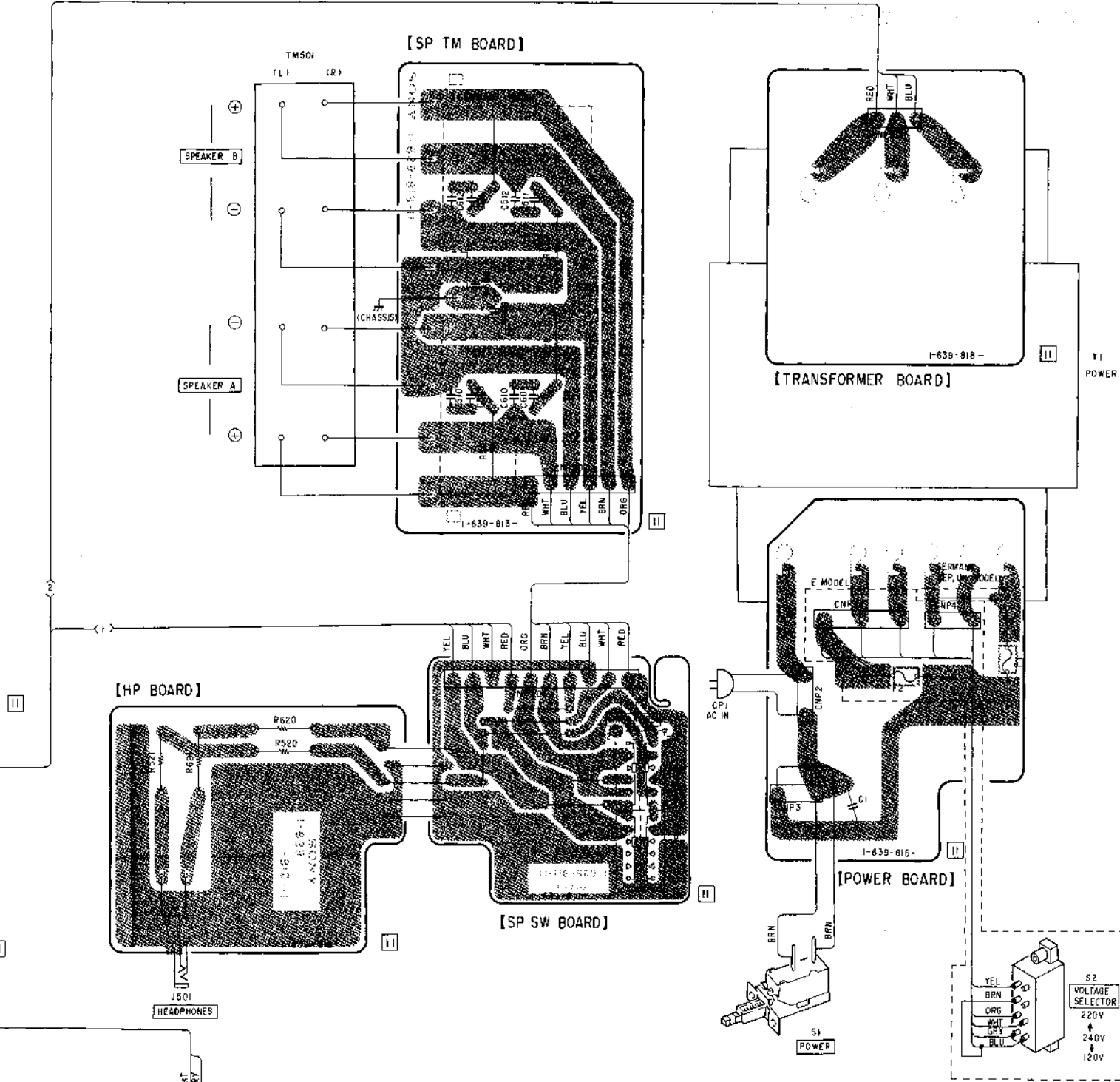
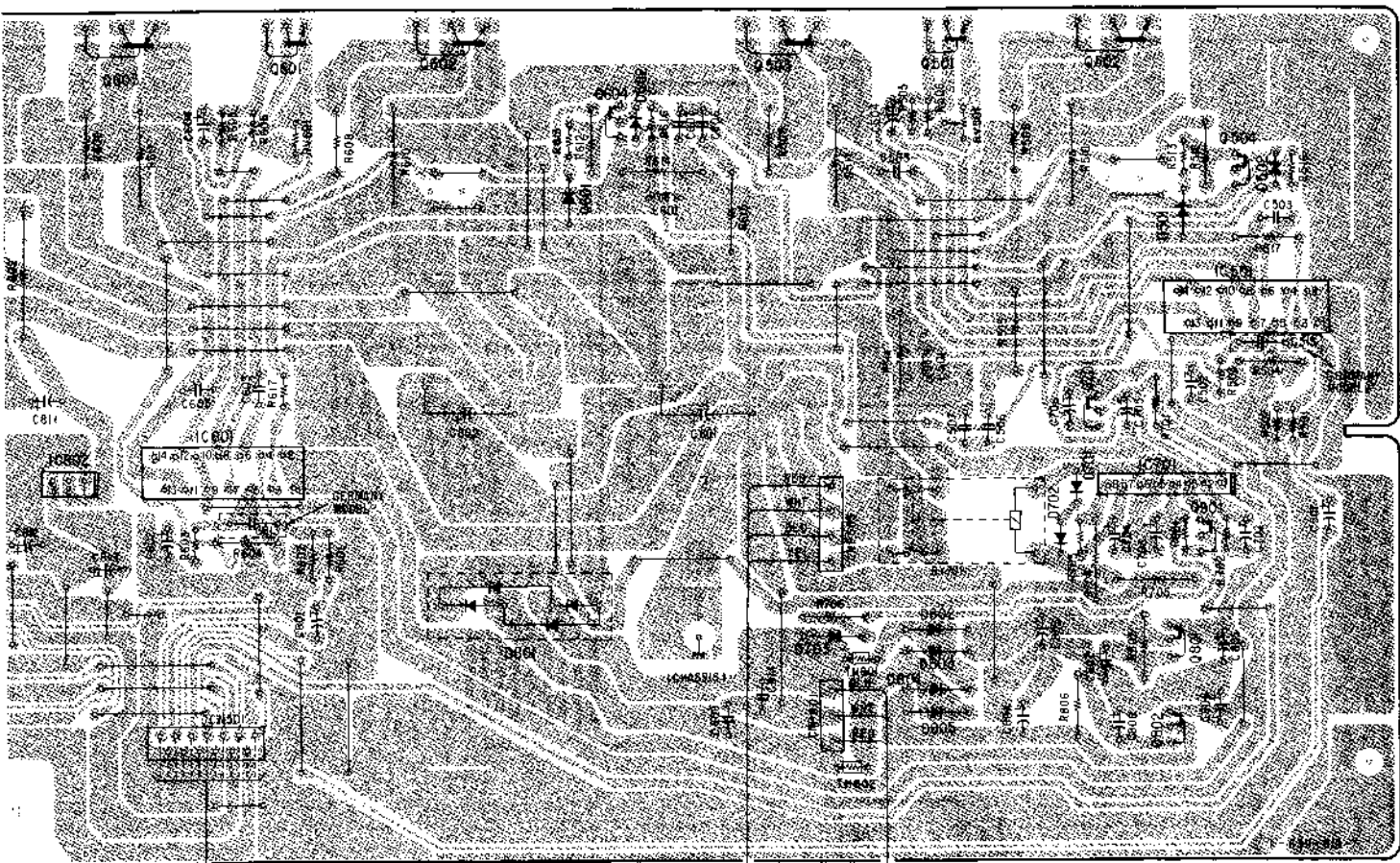

Note:
 ● ○ : parts extracted from the component side.

4-3. SCHEMATIC DIAGRAM

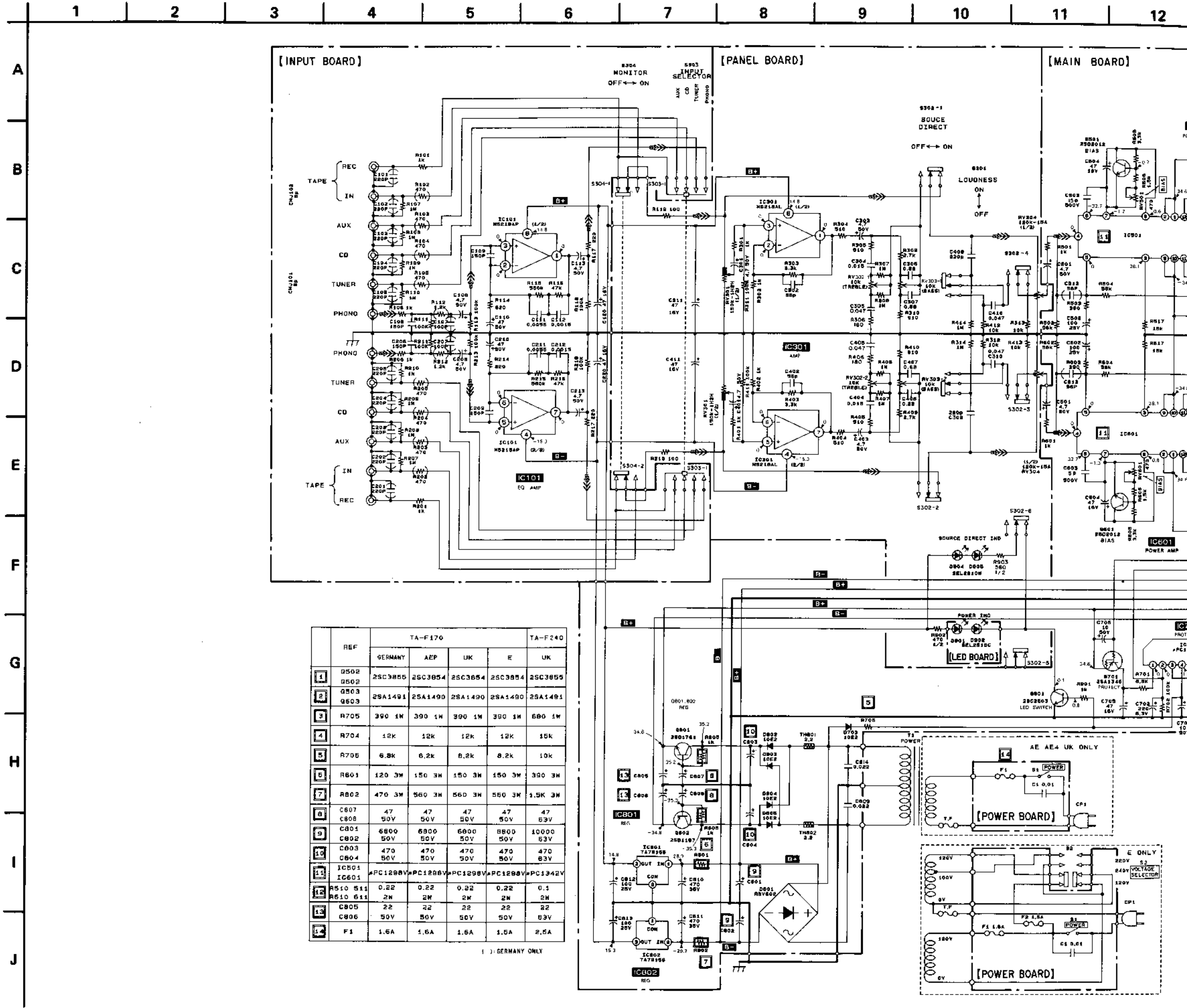

REF	TA-F170				TA-F240
	GERMANY	AEP	UK	E	UK
1	D502	25C3855	25C3854	25C3854	25C3855
2	D503	25A1491	25A1490	25A1490	25A1491
3	R705	390 1K	390 1M	390 1M	390 1M
4	R704	12K	12K	12K	15K
5	R706	6.8K	6.2K	8.2K	10K
6	R801	120 3W	150 3W	150 3W	300 3W
7	R802	470 3W	560 3W	560 3W	1.5K 3W
8	C807	47	47	47	47
9	C808	50V	50V	50V	50V
10	C801	6800	6800	6800	10000
11	C802	50V	50V	50V	50V
12	C803	470	470	470	470
13	C804	50V	50V	50V	50V
14	IC601	PC1288V	PC1288V	PC1288V	PC1342V
15	R510	511	0.22	0.22	0.1
16	R610	611	2M	2M	2M
17	C805	22	22	22	22
18	C806	50V	50V	50V	50V
19	F1	1.6A	1.6A	1.6A	2.5A

1. GERMANY ONLY

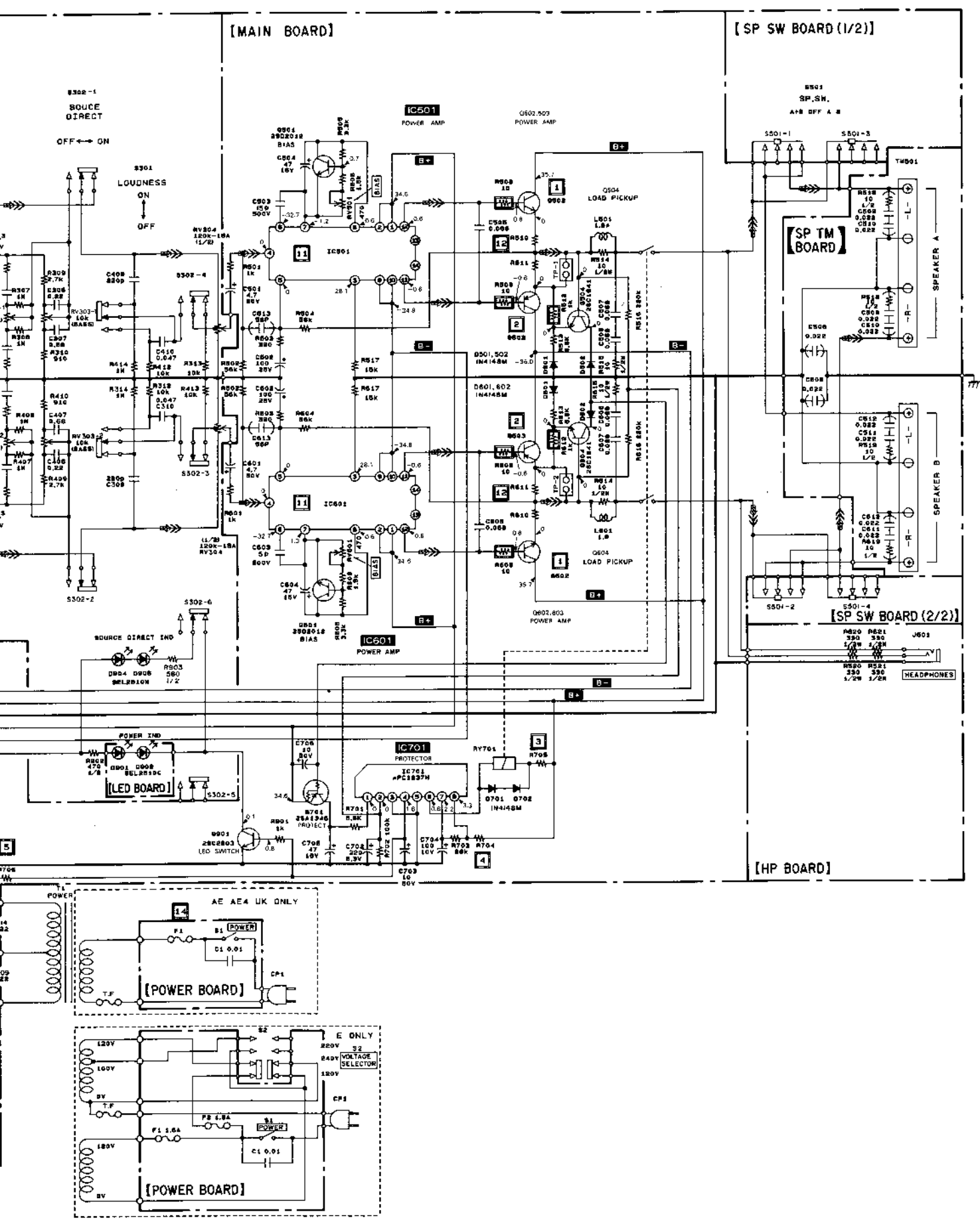

IC Block Diagrams

IC501, 601 μ PC1298V

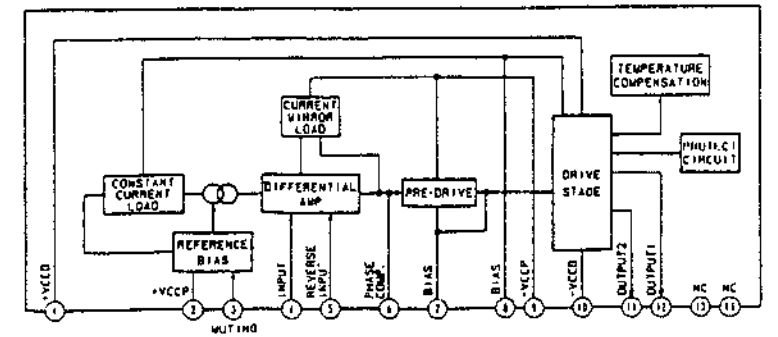

IC701 μ PC1237HA

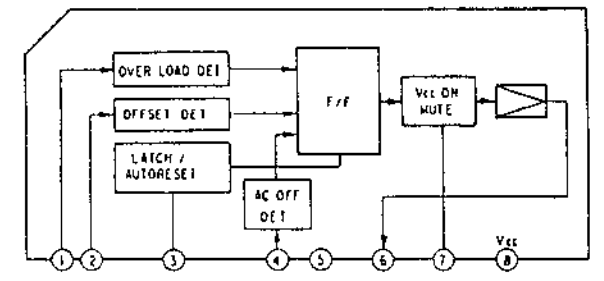

- Note:**
- All capacitors are in μ F unless otherwise noted. pF: μ F 50 WV or less are not indicated except for electrolytics and tantalums.
 - All resistors are in Ω and $\frac{1}{4}$ W or less unless otherwise specified.
 - : nonflammable resistor.

<p>Note: The components identified by mark or dotted line with mark are critical for safety. Replace only with part number specified.</p>	<p>Note: Les composants identifiés par une marque sont critiques pour la sécurité. Ne les remplacer que par une pièce portant le numéro spécifié.</p>
--	---

- : B + Line.
- : B - Line.
- : adjustment for repair.
- Voltages and waveforms are dc with respect to ground under no-signal (detuned) conditions.
- Voltages are taken with a VOM (10 M Ω /V). Voltage variations may be noted due to normal production tolerances.
- Signal path.
- : PHONO

SECTION 5 EXPLODED VIEWS

NOTE:

- -XX and -X mean standardized parts, so they may have some difference from the original one.
- Color Indication of Appearance Parts
Example:
KNOB, BALANCE (WHITE) ... (RED)

↑ ↑
Parts Color Cabinet's Color

- Items marked "*" are not stocked since they are seldom required for routine service. Some delay should be anticipated when ordering these items.
- The mechanical parts with no reference number in the exploded views are not supplied.
- Hardware (# mark) list is given in the last of this parts list.

The components identified by mark Δ or dotted line with mark Δ are critical for safety. Replace only with part number specified.

Les composants identifiés par une marque Δ sont critiques pour la sécurité. Ne les remplacer que par une pièce portant le numéro spécifié.

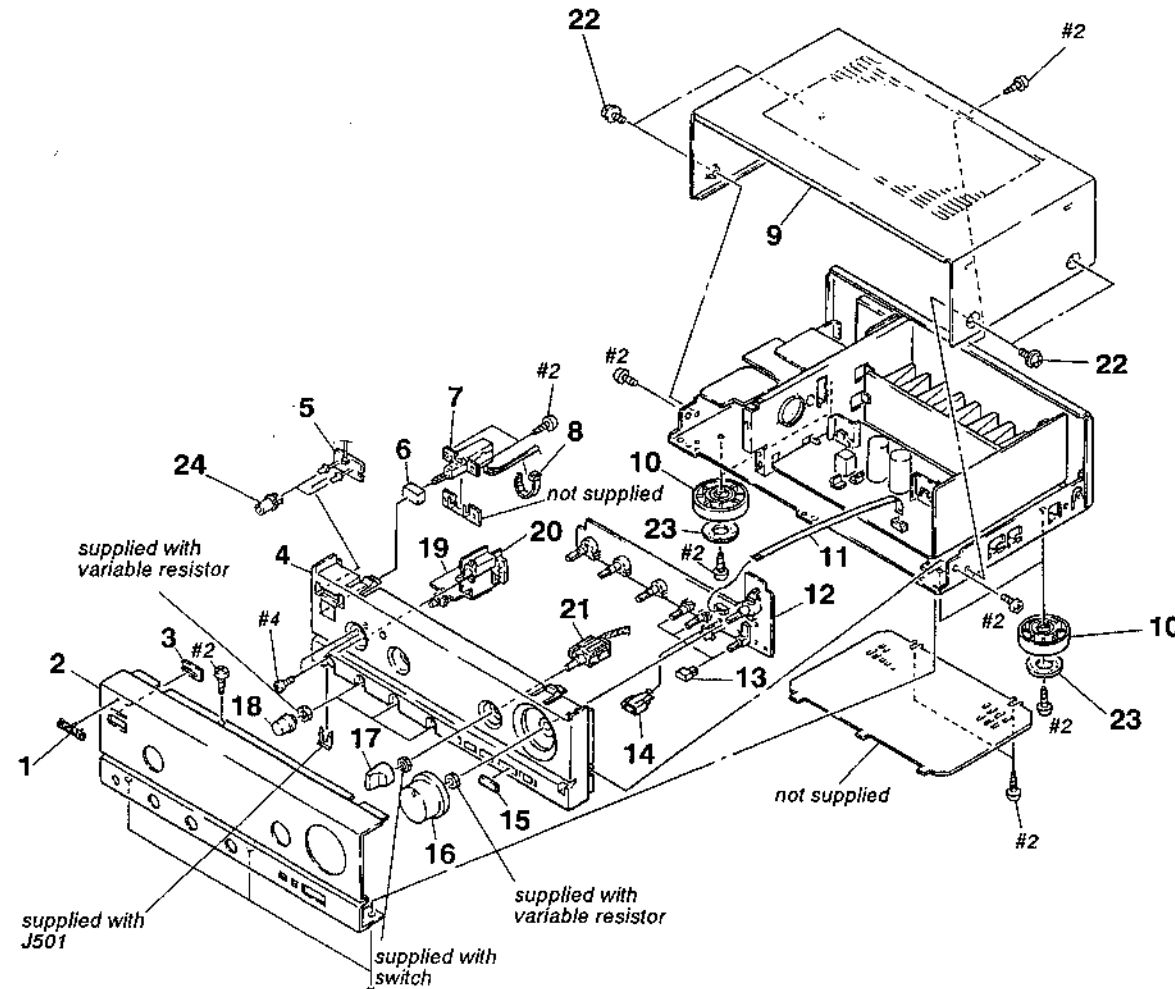

Ref. No.	Part No.	Description	Remark
1	4-908-848-01	EMBLEM, SONY	
2	4-945-182-01	PANEL, FRONT (F170)	
2	4-945-182-11	PANEL, FRONT (F240)	
3	4-945-175-01	INDICATOR (PSW)	
4	* 4-945-181-01	PANEL (BASE), FRONT	
5	* 1-639-817-11	LED BOARD	
6	4-929-289-01	BUTTON	
7	1-553-318-41	SWITCH, PUSH (AC POWER) (1 KEY)	
8	3-655-653-21	BAND (TAITON), BINDING (F170:AEP, UK, GERMANY/F240)	
9	4-929-294-11	CASE	
10	X-3304-938-2	FOOT ASSY	
11	1-590-036-11	WIRE, FLAT TYPE (13 CORE)	

Ref. No.	Part No.	Description	Remark
12	* A-4345-123-A	PANEL BOARD, COMPLETE (F240)	
12	* A-4345-133-A	PANEL BOARD, COMPLETE (F170)	
13	4-945-176-01	BUTTON (18X11)	
14	4-945-177-01	HOUSE, LIGHTING	
15	4-945-622-01	PLATE (S/D), INDICATION	
16	X-4941-616-1	KNOB (R53) ASSY	
17	4-945-173-01	KNOB (R21)	
18	4-945-174-01	KNOB (F25)	
19	* 1-639-812-11	H.P BOARD	
20	* 1-639-811-11	SP SW BOARD	
21	1-572-803-11	SWITCH, ROTARY SLIDE (INPUT SELECTOR)	
22	3-704-366-01	SCREW (CASE) (M3X8)	
23	4-923-836-11	CUSHION	
24	* 3-362-478-21	HOLDER (T), LED	

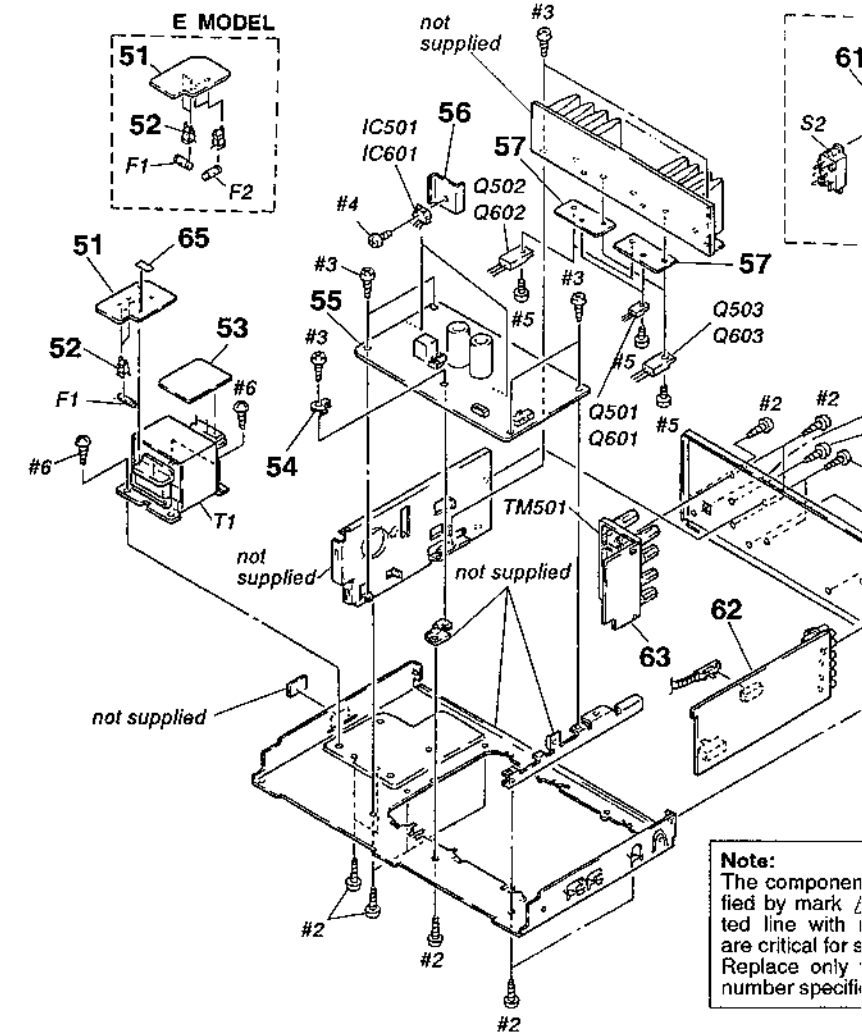

Ref. No.	Part No.	Description	Remark	Ref. No.	Part No.	Description	Remark
51	* 1-639-816-11	POWER BOARD		61	* 4-944-986-		
52	* 1-533-225-11	HOLDER, FUSE		61	* 4-944-986-		
53	* 1-639-818-11	TRANSFORMER BOARD		61	* 4-944-986-		
54	* 4-942-204-01	PLATE, GROUND		62	* 1-639-814-		
55	* A-4345-128-A	MAIN BOARD, COMPLETE (F240)		63	* 1-639-813-		
55	* A-4345-138-A	MAIN BOARD, COMPLETE (F170:AEP, UK)		64	Δ 1-569-007-		
55	* A-4345-143-A	MAIN BOARD, COMPLETE (F170:GERMANY)		65	3-701-947-		
55	* A-4345-154-A	MAIN BOARD, COMPLETE (F170:E)		CP1	Δ 1-575-651-		
56	* 4-931-998-11	HEAT SINK (S) (F170)		CP1	Δ 1-575-652-		
56	* 4-931-998-21	HEAT SINK (S) (F240)		CP1	Δ 1-575-653-		
57	4-945-480-01	SHEET, INSULATING		F1	Δ 1-532-286-		
58	* 3-703-571-11	BUSHING (S) (4516), CORD (F170:E)		F1	Δ 1-532-259-		
58	* 3-703-244-00	BUSHING (2104), CORD		F2	Δ 1-532-259-		
59	* 2-379-614-01	HOOK		S2	Δ 1-570-307-		
60	3-706-165-00	SCREW		T1	Δ 1-450-575-		
61	* 4-941-986-41	PANEL, BACK (F170:E)		T1	Δ 1-450-576-		
61	* 4-941-986-51	PANEL, BACK (F240)		T1	Δ 1-450-577-		
				T1	Δ 1-450-578-		
				T1	Δ 1-450-579-		

SECTION 6 ELECTRICAL PARTS LIST

MAIN SP SW H. P SP TM INPUT

NOTE:

- Due to standardization, replacements in the parts list may be different from the parts specified in the diagrams or the components used on the set.
- -XX and -X mean standardized parts, so they may have some difference from the original one.
- **RESISTORS**
All resistors are in ohms.
METAL: Metal-film resistor
METAL OXIDE: Metal Oxide-film resistor
F: nonflammable
- Items marked "*" are not stocked since they are seldom required for routine service. Some delay should be anticipated when ordering these items.
- **SEMICONDUCTORS**
In each case, u: μ , for example:
uA...: μ A... uPA...: μ PA...
uPB...: μ PB... uPC...: μ PC...
uPD...: μ PD...
- **CAPACITORS**
uF: μ F
- **COILS**
uH: μ H

The components identified by mark Δ or dotted line with mark Δ are critical for safety. Replace only with part number specified.

Les composants identifiés par une marque Δ sont critiques pour la sécurité. Ne les remplacer que par une pièce portant le numéro spécifié.

When including parts by reference number, please include the board name.

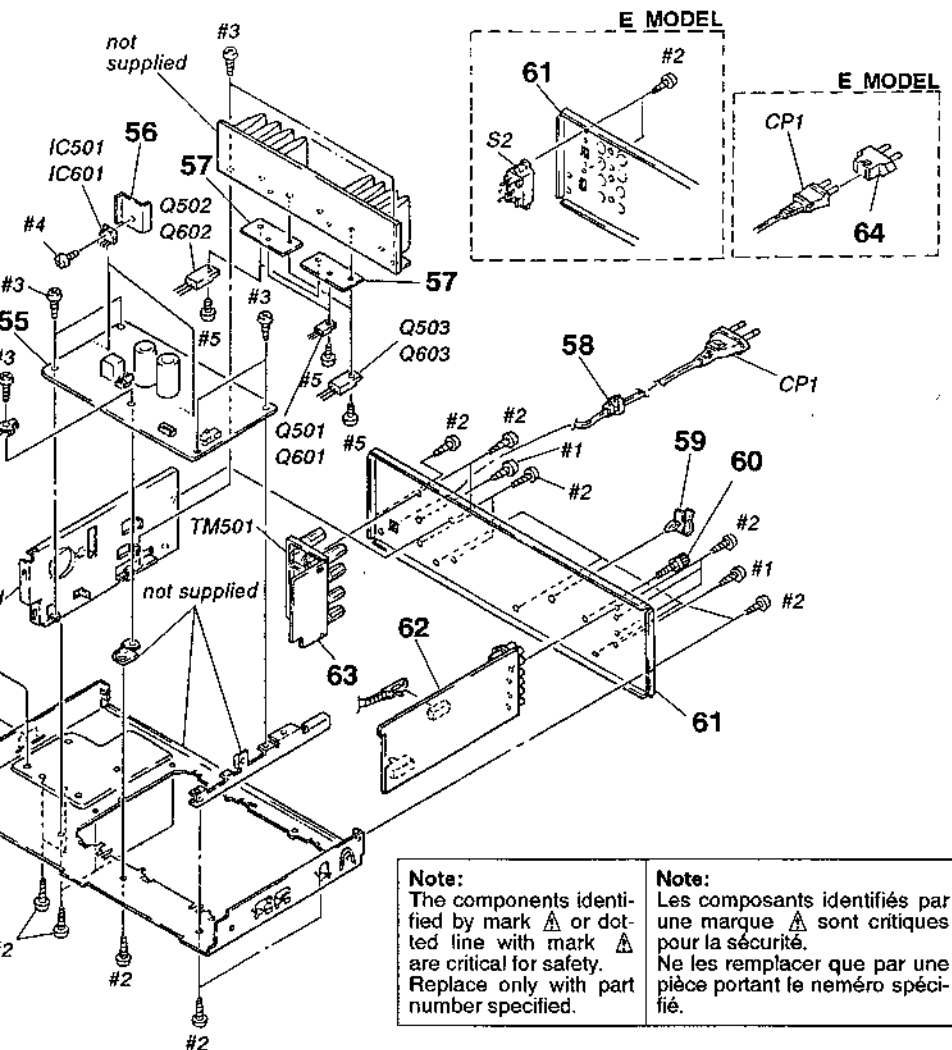

Note:
The components identified by mark Δ or dotted line with mark Δ are critical for safety. Replace only with part number specified.

Note:
Les composants identifiés par une marque Δ sont critiques pour la sécurité. Ne les remplacer que par une pièce portant le numéro spécifié.

Ref. No.	Part No.	Description	Remark	Ref. No.	Part No.	Description	Remark
	* A-4345-128-A	MAIN BOARD, COMPLETE (F240)		C503	1-102-316-00	CERAMIC 15PF 5% 500V	
	* A-4345-138-A	MAIN BOARD, COMPLETE (F170:AEP, UK)		C504	1-126-022-11	ELECT 47uF 20% 16V	
	* A-4345-143-A	MAIN BOARD, COMPLETE (F170:GERMANY)		C505	1-136-163-00	FILM 0.068uF 5% 50V	
	* A-4345-154-A	MAIN BOARD, COMPLETE (F170:E)		C506	1-136-163-00	FILM 0.068uF 5% 50V	
	*****			C507	1-136-163-00	FILM 0.068uF 5% 50V	
	* 1-639-811-11	SP SW BOARD		C508	1-136-157-00	FILM 0.022uF 5% 50V	
	*****					(F170:GERMANY)	
	* 1-639-812-11	H. P. BOARD		C509	1-136-157-00	FILM 0.022uF 5% 50V	
	*****					(F170:GERMANY)	
	* 1-639-813-11	SP TM BOARD		C510	1-136-157-00	FILM 0.022uF 5% 50V	
	*****					(F170:GERMANY)	
	* 1-639-814-11	INPUT BOARD		C511	1-136-157-00	FILM 0.022uF 5% 50V	
	*****					(F170:GERMANY)	
	* 4-931-998-11	HEAT SINX (S) (F170)		C512	1-136-157-00	FILM 0.022uF 5% 50V	
	* 4-931-998-21	HEAT SINX (S) (F240)				(F170:GERMANY)	
	* 4-942-204-01	PLATE, GROUND		C513	1-162-217-11	CERAMIC 56PF	
	7-682-548-04	SCREW +BVTT 3X8 (S)				(F170:GERMANY)	
	< CAPACITOR >						
C101	1-162-286-31	CERAMIC 220PF 10% 50V		C601	1-126-163-11	ELECT 4.7uF 20% 50V	
		(F170:GERMANY)		C602	1-126-023-11	ELECT 100uF 20% 25V	
C102	1-162-286-31	CERAMIC 220PF 10% 50V		C603	1-102-316-00	CERAMIC 15PF 5% 500V	
		(F170:GERMANY)		C604	1-126-022-11	ELECT 47uF 20% 16V	
C103	1-162-286-31	CERAMIC 220PF 10% 50V		C605	1-136-163-00	FILM 0.068uF 5% 50V	
		(F170:GERMANY)		C606	1-136-163-00	FILM 0.068uF 5% 50V	
C104	1-162-286-31	CERAMIC 220PF 10% 50V		C607	1-136-163-00	FILM 0.068uF 5% 50V	
		(F170:GERMANY)		C608	1-136-157-00	FILM 0.022uF 5% 50V	
C105	1-162-286-31	CERAMIC 220PF 10% 50V				(F170:GERMANY)	
		(F170:GERMANY)		C609	1-136-157-00	FILM 0.022uF 5% 50V	
C106	1-164-075-11	CERAMIC 150PF 10% 50V				(F170:GERMANY)	
C107	1-164-070-11	CERAMIC 100PF 5% 50V		C610	1-136-157-00	FILM 0.022uF 5% 50V	
		(F170:GERMANY)				(F170:GERMANY)	
C108	1-126-163-11	ELECT 4.7uF 20% 50V		C611	1-136-157-00	FILM 0.022uF 5% 50V	
C109	1-164-075-11	CERAMIC 150PF 10% 50V				(F170:GERMANY)	
C110	1-126-051-11	ELECT 47uF 20% 50V		C612	1-136-157-00	FILM 0.022uF 5% 50V	
C111	1-130-480-00	MYLAR 0.0056uF 5% 50V				(F170:GERMANY)	
C112	1-130-473-00	MYLAR 0.0015uF 5% 50V		C613	1-162-217-11	CERAMIC 56PF	
C113	1-126-163-11	ELECT 4.7uF 20% 50V				(F170:GERMANY)	
C120	1-126-022-11	ELECT 47uF 20% 16V		C702	1-124-982-81	ELECT 220uF 20% 6.3V	
C201	1-162-286-31	CERAMIC 220PF 10% 50V		C703	1-126-059-11	ELECT 10uF 20% 50V	
		(F170:GERMANY)		C704	1-124-994-11	ELECT 100uF 20% 10V	
C202	1-162-286-31	CERAMIC 220PF 10% 50V		C705	1-126-022-11	ELECT 47uF 20% 16V	
		(F170:GERMANY)		C706	1-126-059-11	ELECT 10uF 20% 50V	
C203	1-162-286-31	CERAMIC 220PF 10% 50V				(F170:GERMANY)	
		(F170:GERMANY)		C801	1-125-686-11	ELECT 6800uF 20% 50V (F170)	
C204	1-162-286-31	CERAMIC 220PF 10% 50V				(F170:GERMANY)	
		(F170:GERMANY)		C801	1-128-342-11	ELECT 10000uF 20% 63V (F240)	
C205	1-162-286-31	CERAMIC 220PF 10% 50V				(F170:GERMANY)	
		(F170:GERMANY)		C802	1-125-686-11	ELECT 6800uF 20% 50V (F170)	
C206	1-164-075-11	CERAMIC 150PF 10% 50V				(F170:GERMANY)	
C207	1-164-070-11	CERAMIC 100PF 5% 50V		C802	1-128-342-11	ELECT 10000uF 20% 63V (F240)	
		(F170:GERMANY)				(F170:GERMANY)	
C208	1-126-163-11	ELECT 4.7uF 20% 50V		C803	1-124-921-11	ELECT 470uF 20% 63V (F240)	
C209	1-164-075-11	CERAMIC 150PF 10% 50V				(F170:GERMANY)	
C210	1-126-051-11	ELECT 47uF 20% 50V		C803	1-126-055-11	ELECT 470uF 20% 50V (F170)	
C211	1-130-480-00	MYLAR 0.0056uF 5% 50V				(F170:GERMANY)	
C212	1-130-473-00	MYLAR 0.0015uF 5% 50V		C804	1-124-921-11	ELECT 470uF 20% 63V (F240)	
C213	1-126-163-11	ELECT 4.7uF 20% 50V				(F170:GERMANY)	
C220	1-126-022-11	ELECT 47uF 20% 16V		C804	1-126-055-11	ELECT 470uF 20% 50V (F170)	
C501	1-126-163-11	ELECT 4.7uF 20% 50V				(F170:GERMANY)	
C502	1-126-023-11	ELECT 100uF 20% 25V		C805	1-124-916-11	ELECT 22uF 20% 63V (F240)	

Remark	Ref. No.	Part No.	Description	Remark
	61	* 4-944-986-11	PANEL, BACK (F170:AEP)	
	61	* 4-944-986-21	PANEL, BACK (F170:GERMANY)	
	61	* 4-944-986-31	PANEL, BACK (F170:UK)	
	62	* 1-639-814-11	INPUT BOARD	
	63	* 1-639-813-11	SP TM BOARD	
	64	Δ 1-569-007-11	ADAPTOR, CONVERSION 2P (F170:E)	
	65	3-701-947-15	LABEL (2.5A), FUSE (F240)	
	CP1	Δ 1-575-651-11	CORD, POWER (AEP, GERMANY)	
	CP1	Δ 1-575-652-11	CORD, POWER (UK)	
	CP1	Δ 1-575-653-11	CORD, POWER (E)	
	F1	Δ 1-532-286-00	FUSE (F240)	
	F1	Δ 1-532-259-00	FUSE (F170)	
	F2	Δ 1-532-259-00	FUSE (F170:E)	
	S2	Δ 1-570-307-11	SWITCH, VOLTAGE CHANGE (F170:E)	
	T1	Δ 1-450-575-11	TRANSFORMER, POWER (F240)	
	T1	Δ 1-450-576-11	TRANSFORMER, POWER (F170:AEP)	
	T1	Δ 1-450-577-11	TRANSFORMER, POWER (F170:GERMANY)	
	T1	Δ 1-450-578-11	TRANSFORMER, POWER (F170:UK)	
	T1	Δ 1-450-579-11	TRANSFORMER, POWER (F170:E)	

MAIN

SP SW

H. P

SP TM

INPUT

Ref. No.	Part No.	Description	Remark
C807	1-126-051-11	ELECT	47uF 20% 50V (F170)
C807	1-126-062-11	ELECT	47uF 20% 63V (F240)
C808	1-126-051-11	ELECT	47uF 20% 50V (F170)
C808	1-126-062-11	ELECT	47uF 20% 63V (F240)
C809	1-106-375-12	MYLAR	0.022uF 5% 200V
C810	1-126-104-11	ELECT	470uF 20% 35V
C811	1-126-104-11	ELECT	470uF 20% 35V
C812	1-126-023-11	ELECT	100uF 20% 25V
C813	1-126-023-11	ELECT	100uF 20% 25V
C814	1-106-375-12	MYLAR	0.022uF 5% 200V

< CONNECTOR >

CN501	* 1-568-832-11	SOCKET, CONNECTOR 13P
CNJ101	* 1-566-883-61	JACK, PIN 6P
CNJ102	* 1-566-883-51	JACK, PIN 6P
CNJ103	? 1-573-299-11	CONNECTOR, BOARD TO BOARD 10P
CNP301	? 1-573-296-11	CONNECTOR, BOARD TO BOARD 10P
CNP502	* 1-564-243-00	PIN, CONNECTOR 6P
CNP503	* 1-506-599-11	PIN, CONNECTOR 10P
CNP505	* 1-564-241-00	PIN, CONNECTOR 4P
CNP801	* 1-564-104-00	PIN, CONNECTOR 3P

< DIODE >

D501	8-719-912-20	DIODE 1SS120
D502	8-719-912-20	DIODE 1SS120
D601	8-719-912-20	DIODE 1SS120
D602	8-719-912-20	DIODE 1SS120
D701	8-719-912-20	DIODE 1SS120
D702	8-719-912-20	DIODE 1SS120
D703	8-719-200-77	DIODE 10E2N
D801	8-719-302-38	DIODE RBV-602-01
D802	8-719-200-77	DIODE 10E2N
D803	8-719-200-77	DIODE 10E2N
D804	8-719-200-77	DIODE 10E2N
D805	8-719-200-77	DIODE 10E2N

< IC >

IC101	8-759-636-74	IC M5218AP-22
IC501	8-759-109-06	IC uPC1298V (F170)
IC501	8-759-144-04	IC uPC1342V (F240)
IC601	8-759-109-06	IC uPC1298V (F170)
IC601	8-759-144-04	IC uPC1342V (F240)
IC701	8-759-111-68	IC uPC1237HA
IC801	8-759-231-59	IC TA7815S
IC802	8-759-245-87	IC TA7915S

< JACK >

J501	1-507-796-71	JACK (HEADPHONES)
------	--------------	-------------------

Ref. No.	Part No.	Description	Remark
----------	----------	-------------	--------

< COIL >

L501	* 1-420-872-00	COIL, AIR CORE
L601	* 1-420-872-00	COIL, AIR CORE

< TRANSISTOR >

Q501	8-729-209-15	TRANSISTOR 2SD2012
Q502	8-729-320-83	TRANSISTOR 2SC3855-0Y (F170:GERMANY/F240)
Q502	8-729-321-96	TRANSISTOR 2SC3854-0Y (F170:AEP, UK, E)
Q503	8-729-320-86	TRANSISTOR 2SA1491-0Y (F170:GERMANY/F240)
Q503	8-729-322-02	TRANSISTOR 2SA1490-OPY (F170:AEP, UK, E)
Q504	8-729-140-84	TRANSISTOR 2SC1841TP-PAFAEA
Q601	8-729-209-15	TRANSISTOR 2SD2012
Q602	8-729-320-83	TRANSISTOR 2SC3855-0Y (F170:GERMANY/F240)
Q602	8-729-321-96	TRANSISTOR 2SC3854-0Y (F170:AEP, UK, E)
Q603	8-729-320-86	TRANSISTOR 2SA1491-0Y (F170:GERMANY/F240)
Q603	8-729-322-02	TRANSISTOR 2SA1490-OPY (F170:AEP, UK, E)
Q604	8-729-140-84	TRANSISTOR 2SC1841TP-PAFAEA
Q701	8-729-900-63	TRANSISTOR DTA124ES
Q801	8-729-111-55	TRANSISTOR 2SD1312-K
Q802	8-729-924-90	TRANSISTOR 2SB1370-EF
Q901	8-729-620-05	TRANSISTOR 2SC2603-EF

< RESISTOR >

R101	1-249-417-11	CARBON	1K	5%	1/4W
R102	1-249-413-11	CARBON	470	5%	1/4W (F170:GERMANY)
R103	1-249-413-11	CARBON	470	5%	1/4W (F170:GERMANY)
R104	1-249-413-11	CARBON	470	5%	1/4W (F170:GERMANY)
R105	1-249-413-11	CARBON	470	5%	1/4W (F170:GERMANY)
R106	1-249-417-11	CARBON	1K	5%	1/4W
R107	1-247-903-00	CARBON	1M	5%	1/4W
R108	1-247-903-00	CARBON	1M	5%	1/4W
R109	1-247-903-00	CARBON	1M	5%	1/4W
R110	1-247-903-00	CARBON	1M	5%	1/4W
R111	1-249-441-11	CARBON	100K	5%	1/4W
R112	1-249-418-11	CARBON	1.2K	5%	1/4W (F170:GERMANY)
R113	1-249-441-11	CARBON	100K	5%	1/4W
R114	1-249-416-11	CARBON	820	5%	1/4W
R115	1-247-897-11	CARBON	560K	5%	1/4W
R116	1-249-437-11	CARBON	47K	5%	1/4W
R117	1-249-409-11	CARBON	220	5%	1/4W
R118	1-249-441-11	CARBON	100K	5%	1/4W
R201	1-249-417-11	CARBON	1K	5%	1/4W
R202	1-249-413-11	CARBON	470	5%	1/4W (F170:GERMANY)
R203	1-249-413-11	CARBON	470	5%	1/4W (F170:GERMANY)
R204	1-249-413-11	CARBON	470	5%	1/4W (F170:GERMANY)
R205	1-249-413-11	CARBON	470	5%	1/4W (F170:GERMANY)
R206	1-249-417-11	CARBON	1K	5%	1/4W

MAIN

SP SW

H. P

SP TM

INPUT

PANEL

Note:
The components identified by mark Δ or dotted line with mark Δ are critical for safety. Replace only with part number specified.

Note:
Les composants identifiés par une marque Δ sont critiques pour la sécurité. Ne les remplacer que par une pièce portant le numéro spécifié.

Ref. No.	Part No.	Description	Remark
R207	1-247-903-00	CARBON 1M 5% 1/4W	
R208	1-247-903-00	CARBON 1M 5% 1/4W	
R209	1-247-903-00	CARBON 1M 5% 1/4W	
R210	1-247-903-00	CARBON 1M 5% 1/4W	
R211	1-249-441-11	CARBON 100K 5% 1/4W	
R212	1-249-418-11	CARBON 1.2K 5% 1/4W (F170:GERMANY)	
R213	1-249-441-11	CARBON 100K 5% 1/4W	
R214	1-249-416-11	CARBON 820 5% 1/4W	
R215	1-247-897-11	CARBON 560K 5% 1/4W	
R216	1-249-437-11	CARBON 47K 5% 1/4W	
R217	1-249-409-11	CARBON 220 5% 1/4W	
R218	1-249-441-11	CARBON 100K 5% 1/4W	
R501	1-249-417-11	CARBON 1K 5% 1/4W	
R502	1-249-438-11	CARBON 56K 5% 1/4W	
R503	1-249-412-11	CARBON 390 5% 1/4W	
R504	1-249-466-11	CARBON 56K 5% 1/4W	
R505	1-249-423-11	CARBON 3.3K 5% 1/4W	
R506	1-249-419-11	CARBON 1.5K 5% 1/4W	
R508	1-247-688-11	CARBON 10 5% 1/4W	
R509	1-247-688-11	CARBON 10 5% 1/4W	
R510 Δ	1-216-361-00	METAL OXIDE 0.22 5% 2W F (F170)	
R510 Δ	1-217-611-00	METAL OXIDE 0.1 10% 2W F (F240)	
R511 Δ	1-216-361-00	METAL OXIDE 0.22 5% 2W F (F170)	
R511 Δ	1-217-611-00	METAL OXIDE 0.1 10% 2W F (F240)	
R512	1-247-713-11	CARBON 1K 5% 1/4W	
R513	1-249-427-11	CARBON 6.8K 5% 1/4W	
R514	1-247-727-11	CARBON 10 5% 1/2W	
R515	1-247-727-11	CARBON 10 5% 1/2W	
R516	1-247-887-00	CARBON 220K 5% 1/4W	
R517	1-249-431-11	CARBON 15K 5% 1/4W	
R518	1-247-727-11	CARBON 10 5% 1/2W (F170:GERMANY)	
R519	1-247-727-11	CARBON 10 5% 1/2W (F170:GERMANY)	
R520	1-247-745-11	CARBON 330 5% 1/2W	
R521	1-247-745-11	CARBON 330 5% 1/2W	
R601	1-249-417-11	CARBON 1K 5% 1/4W	
R602	1-249-438-11	CARBON 56K 5% 1/4W	
R603	1-249-412-11	CARBON 390 5% 1/4W	
R604	1-249-466-11	CARBON 56K 5% 1/4W	
R605	1-249-423-11	CARBON 3.3K 5% 1/4W	
R606	1-249-419-11	CARBON 1.5K 5% 1/4W	
R608	1-247-688-11	CARBON 10 5% 1/4W	
R609	1-247-688-11	CARBON 10 5% 1/4W	
R610 Δ	1-216-361-00	METAL OXIDE 0.22 5% 2W F (F170)	
R610 Δ	1-217-611-00	METAL OXIDE 0.1 10% 2W F (F240)	
R611 Δ	1-216-361-00	METAL OXIDE 0.22 5% 2W F (F170)	
R611 Δ	1-217-611-00	METAL OXIDE 0.1 10% 2W F (F240)	
R612	1-247-713-11	CARBON 1K 5% 1/4W	
R613	1-249-427-11	CARBON 6.8K 5% 1/4W	
R614	1-247-727-11	CARBON 10 5% 1/2W	
R615	1-247-727-11	CARBON 10 5% 1/2W	
R616	1-247-887-00	CARBON 220K 5% 1/4W	
R617	1-249-431-11	CARBON 15K 5% 1/4W	
R618	1-247-727-11	CARBON 10 5% 1/2W (F170:GERMANY)	
R619	1-247-727-11	CARBON 10 5% 1/2W (F170:GERMANY)	

Ref. No.	Part No.	Description	Remark
R620	1-247-745-11	CARBON 330 5% 1/2W	
R621	1-247-745-11	CARBON 330 5% 1/2W	
R701	1-249-427-11	CARBON 6.8K 5% 1/4W	
R702	1-249-441-11	CARBON 100K 5% 1/4W	
R703	1-249-439-11	CARBON 68K 5% 1/4W	
R704	1-249-430-11	CARBON 12K 5% 1/4W (F170)	
R704	1-249-431-11	CARBON 15K 5% 1/4W (F240)	
R705 Δ	1-215-868-00	METAL OXIDE 680 5% 1W F (F240)	
R705 Δ	1-216-430-11	METAL OXIDE 390 5% 1W F (F170)	
R706	1-249-427-11	CARBON 6.8K 5% 1/4W (F170:GERMANY)	
R706	1-249-428-11	CARBON 8.2K 5% 1/4W (F170:AEP, UK, E)	
R706	1-249-429-11	CARBON 10K 5% 1/4W (F240)	
R801 Δ	1-215-912-11	METAL OXIDE 350 5% 3W F (F170:AEP, UK, E)	
R801 Δ	1-216-475-11	METAL OXIDE 120 5% 3W F (F170:GERMANY)	
R801 Δ	1-216-478-11	METAL OXIDE 390 5% 3W F (F240)	
R802 Δ	1-215-915-11	METAL OXIDE 470 5% 3W F (F170:GERMANY)	
R802 Δ	1-215-918-00	METAL OXIDE 1.5K 5% 3W F (F240)	
R802 Δ	1-216-479-11	METAL OXIDE 560 5% 3W F (F170:AEP, UK, E)	
R805	1-249-417-11	CARBON 1K 5% 1/4W	
R806	1-249-417-11	CARBON 1K 5% 1/4W	
R901	1-249-417-11	CARBON 1K 5% 1/4W	
		< VARIABLE RESISTOR >	
RV501	1-238-596-11	RES. ADJ. CARBON 470	
RV601	1-238-596-11	RES. ADJ. CARBON 470	
		< RELAY >	
RY701	1-515-501-00	RELAY	
		< SWITCH >	
S303	1-572-804-11	SWITCH, SLIDE (INPUT SELECTOR)	
S501	1-571-973-11	SWITCH, ROTARY (SPEAKERS)	
		< TERMINAL >	
TM501	1-537-227-11	TERMINAL BOARD (SP) (F170:AEP)	
TM501	1-537-228-11	TERMINAL BOARD (SP) (F170:GERMANY)	
TM501	1-537-235-11	TERMINAL BOARD (SP) (F170:UK, E/F240)	
TM801	1-808-881-91	THERMISTOR (POSITIVE) 2.2	
TM802	1-808-881-91	THERMISTOR (POSITIVE) 2.2	

* A-4345-123-A PANEL BOARD, COMPLETE (F240)			
* A-4345-133-A PANEL BOARD, COMPLETE (F170)			

Note:
The components identified by mark Δ or dotted line with mark Δ are critical for safety. Replace only with part number specified.

Note:
Les composants identifiés par une marque Δ sont critiques pour la sécurité. Ne les remplacer que par une pièce portant le numéro spécifié.

PANEL **POWER** **LED** **TRANSFORMER**

Ref. No.	Part No.	Description	Remark
* 1-639-816-11 POWER BOARD			

* 1-639-817-11 LED BOARD			

* 1-639-818-11 TRANSFORMER BOARD			

1-533-225-11 HOLDER, FUSE			
* 1-564-214-11 PIN, CONNECTOR 3P			
* 3-362-476-21 HOLDER (T), LED			
< CAPACITOR >			
C1	Δ 1-161-744-00	CERAMIC	0.01uF 400V
C301	1-126-163-11	ELECT	4.7uF 20% 50V
C302	1-162-217-31	CERAMIC	56PF 5% 50V
C303	1-126-163-11	ELECT	4.7uF 20% 50V
C304	1-136-155-00	FILM	0.015uF 5% 50V
C305	1-136-161-00	FILM	0.047uF 5% 50V
C306	1-136-169-00	FILM	0.22uF 5% 50V
C307	1-136-175-00	FILM	0.68uF 5% 50V
C309	1-162-286-31	CERAMIC	220PF 10% 50V
C310	1-136-161-00	FILM	0.047uF 5% 50V
C311	1-126-022-11	ELECT	47uF 20% 16V
C401	1-126-163-11	ELECT	4.7uF 20% 50V
C402	1-162-217-31	CERAMIC	56PF 5% 50V
C403	1-126-163-11	ELECT	4.7uF 20% 50V
C404	1-136-155-00	FILM	0.015uF 5% 50V
C405	1-136-161-00	FILM	0.047uF 5% 50V
C406	1-136-169-00	FILM	0.22uF 5% 50V
C407	1-136-175-00	FILM	0.68uF 5% 50V
C409	1-162-286-31	CERAMIC	220PF 10% 50V
C410	1-136-161-00	FILM	0.047uF 5% 50V
C411	1-126-022-11	ELECT	47uF 20% 16V
< CONNECTOR >			
CN301	* 1-568-832-11	SOCKET, CONNECTOR 13P	
CNP2	* 1-564-321-00	PIN, CONNECTOR 2P	
CNP3	* 1-564-321-00	PIN, CONNECTOR 2P	
CNP4	* 1-564-321-00	PIN, CONNECTOR 2P (F170:E)	
CNP5	* 1-564-687-11	PIN, CONNECTOR 3P (F170:E)	
< CORD, POWER >			
CP1	Δ 1-575-651-11	CORD, POWER (AEP, GERMANY)	
CP1	Δ 1-575-652-11	CORD, POWER (UK)	
CP1	Δ 1-575-653-11	CORD, POWER (E)	
< DIODE >			
D901	8-719-303-00	DIODE SEL2510C-C	
D902	8-719-303-00	DIODE SEL2510C-C	
D904	8-719-301-52	DIODE SEL2810A-C	
D905	8-719-301-52	DIODE SEL2810A-C	
< FUSE >			
F1	Δ 1-532-286-00	FUSE TIME-LAG 2.5A (F240)	
F1	Δ 1-532-259-00	FUSE TIME-LAG 1.6A (F170)	
F2	Δ 1-532-259-00	FUSE TIME-LAG 1.6A (F170:E)	

Ref. No.	Part No.	Description	Remark
< IC >			
IC301	8-759-634-50	IC M5218AL	
< RESISTOR >			
R119	1-249-405-11	CARBON	100 5% 1/4W
R219	1-249-405-11	CARBON	100 5% 1/4W
R301	1-249-417-11	CARBON	1K 5% 1/4W
R302	1-249-417-11	CARBON	1K 5% 1/4W
R303	1-249-423-11	CARBON	3.3K 5% 1/4W
R304	1-249-442-11	CARBON	510 5% 1/4W
R305	1-249-442-11	CARBON	510 5% 1/4W
R306	1-249-408-11	CARBON	180 5% 1/4W
R307	1-247-903-00	CARBON	1M 5% 1/4W
R308	1-247-903-00	CARBON	1M 5% 1/4W
R309	1-249-422-11	CARBON	2.7K 5% 1/4W
R310	1-247-830-11	CARBON	910 5% 1/4W
R311	1-249-441-11	CARBON	100K 5% 1/4W
R312	1-249-429-11	CARBON	10K 5% 1/4W
R313	1-249-429-11	CARBON	10K 5% 1/4W
R314	1-247-903-00	CARBON	1M 5% 1/4W
R401	1-249-417-11	CARBON	1K 5% 1/4W
R402	1-249-417-11	CARBON	1K 5% 1/4W
R403	1-249-423-11	CARBON	3.3K 5% 1/4W
R404	1-249-442-11	CARBON	510 5% 1/4W
R405	1-249-442-11	CARBON	510 5% 1/4W
R406	1-249-408-11	CARBON	180 5% 1/4W
R407	1-247-903-00	CARBON	1M 5% 1/4W
R408	1-247-903-00	CARBON	1M 5% 1/4W
R409	1-249-422-11	CARBON	2.7K 5% 1/4W
R410	1-247-830-11	CARBON	910 5% 1/4W
R411	1-249-441-11	CARBON	100K 5% 1/4W
R412	1-249-429-11	CARBON	10K 5% 1/4W
R413	1-249-429-11	CARBON	10K 5% 1/4W
R414	1-247-903-00	CARBON	1M 5% 1/4W
R902	1-247-747-11	CARBON	470 5% 1/2W
R903	1-247-749-11	CARBON	560 5% 1/2W
< VARIABLE RESISTOR >			
RV301	1-238-513-11	RES. VAR, CARBON 150K/150K (BALANCE)	
RV302	1-241-548-11	RES. VAR, CARBON 10K (TREBLE)	
RV303	1-241-549-11	RES. VAR, CARBON 10K (BASS)	
RV304	1-241-550-11	RES. VAR, CARBON 120K/120K (VOLUME)	
< SWITCH >			
S1	1-553-318-11	SWITCH, PUSH (1 KEY) (POWER)	
S2	Δ 1-570-307-11	SWITCH (VOLTAGE SELECTOT) (F170:E)	
S301	1-571-112-21	SWITCH, PUSH (1 KEY) (LOUDNESS)	
S302	1-572-642-11	SWITCH, PUSH (1 KEY) (SOURCE DIRECT)	
S304	1-571-872-11	SWITCH, PUSH (1 KEY) (TAPE/DAT MONITOR)	
< TRANSFORMER >			
T1	Δ 1-450-575-11	TRANSFORMER, POWER (F240)	
T1	Δ 1-450-576-11	TRANSFORMER, POWER (F170:AEP)	
T1	Δ 1-450-577-11	TRANSFORMER, POWER (F170:GERMANY)	

PANEL **POWER** **LED** **TRANSFORMER**

Ref. No.	Part No.	Description	Remark
T1	△ · 1-450-578-11	TRANSFORMER, POWER (F170:UK)	
T1	△ · 1-450-579-11	TRANSFORMER, POWER (F170:E)	

MISCELLANEOUS

7	1-553-318-41	SWITCH, PUSH (AC POWER) (1 KEY)	
11	1-590-036-11	WIRE, FLAT TYPE (13 CORE)	
21	1-572-803-11	SWITCH, ROTARY SLIDE (INPUT SELECTOR)	
64	△ · 1-569-007-11	ADAPTOR, CONVERSION 2P (F170:E)	

ACCESSORY & PACKING MATERIAL

- * 3-704-343-01 SHEET (STANDARD), PROTECTION (F240)
- 3-753-389-11 MANUAL, INSTRUCTION (ENGLISH, FRENCH, SPANISH, PORTUGUESE) (AEP, UK, E. GERMANY)
- 3-753-389-41 MANUAL, INSTRUCTION (GERMAN, DUTCH, SWEDISH, ITALIAN) (AEP)
- * 4-944-050-01 INDIVIDUAL CARTON
- * 4-945-810-01 CUSHION (LEFT) (F240)
- * 4-945-811-01 CUSHION (RIGHT) (F240)

HARDWARE LIST

- | | | |
|-----|--------------|----------------------------|
| # 1 | 7-621-849-00 | SCREW (BV/RING) |
| # 2 | 7-685-646-79 | SCREW +BVTP 3X8 TYPE2 N-S |
| # 3 | 7-685-647-79 | SCREW +BVTP 3X10 TYPE2 N-S |
| # 4 | 7-682-548-04 | SCREW +BVTT 3X8 (S) |
| # 5 | 7-682-549-04 | SCREW +BVTT 3X10 (S) |
| # 6 | 7-682-560-04 | SCREW +BVTT 4X6 (S) |

Note:
The components identified by mark △ or dotted line with mark △ are critical for safety. Replace only with part number specified.

Note:
Les composants identifiés par une marque △ sont critiques pour la sécurité. Ne les remplacer que par une pièce portant le numéro spécifié.